

Lawrence Berkeley National Laboratory

LBL Publications

Title

Quadrupole Focusing Lenses for Charged Particles

Permalink

<https://escholarship.org/uc/item/9zh6j880>

Authors

Cork, Bruce

Zajec, Emery

Publication Date

1953-04-01

UCRL-2182

C.2
rpl.

RECEIVED
LAWRENCE
BERKELEY LABORATORY

DEC 2 1985

LIBRARY AND
DOCUMENTS SECTION

TWO-WEEK LOAN COPY

This is a Library Circulating Copy
which may be borrowed for two weeks.

UCRL-2182

C.2
rpl

DISCLAIMER

This document was prepared as an account of work sponsored by the United States Government. While this document is believed to contain correct information, neither the United States Government nor any agency thereof, nor the Regents of the University of California, nor any of their employees, makes any warranty, express or implied, or assumes any legal responsibility for the accuracy, completeness, or usefulness of any information, apparatus, product, or process disclosed, or represents that its use would not infringe privately owned rights. Reference herein to any specific commercial product, process, or service by its trade name, trademark, manufacturer, or otherwise, does not necessarily constitute or imply its endorsement, recommendation, or favoring by the United States Government or any agency thereof, or the Regents of the University of California. The views and opinions of authors expressed herein do not necessarily state or reflect those of the United States Government or any agency thereof or the Regents of the University of California.

UNIVERSITY OF CALIFORNIA

Radiation Laboratory

Contract No. W-7405-eng-48

QUADRUPOLE FOCUSING LENSES FOR CHARGED PARTICLES

Bruce Cork and Emery Zajec

April 15, 1953

QUADRUPOLE FOCUSING LENSES FOR CHARGED PARTICLES

Bruce Cork and Emery Zajec

Radiation Laboratory, Department of Physics,
University of California, Berkeley, California .

April 15, 1953

ABSTRACT

A set of four strong focusing magnetic quadrupole lenses has been constructed and operated. Each lens consists of four air cooled electromagnets with pole tips having a hyperbolic cross section. Each lens is 4 in. long and has an aperture 2 in. in diameter. Measurements of the magnetic field demonstrate that the hyperbolic cross section satisfies the requirements of a constant magnetic field gradient very well. The technique of deflecting a current carrying flexible wire has been used to measure the trajectory of charged particles through the system of lenses. It has been observed that the strong focusing requirements are satisfied. The system of lenses was then used to focus 0.5 Mev protons, 20 Mev deuterons, and 40 Mev alpha particles. The parallel beam of 0.5 Mev protons was detected by observing the incandescence of a quartz plate while the protons were bombarding it. The focused beam was less than 1 mm in diameter. The astigmatic 20 Mev deuteron beam from the 60 in. cyclotron was increased in current density by a factor greater than 30.

QUADRUPOLE FOCUSING LENSES FOR CHARGED PARTICLES

Bruce Cork and Emery Zajec

Radiation Laboratory, Department of Physics,
University of California, Berkeley, California

April 15, 1953

Methods have been described^{1, 2, 3} for accelerating charged particles and maintaining these particles in stable orbits by the use of "strong focusing lenses". These lenses consist of electric or magnetic quadrupoles with the charged particles traveling in the direction of the common axis.

Figure 1 shows a system for deflecting a parallel beam of charged particles so that they are brought to a focus at the point F, a distance beyond the last lens. Figure 2 shows the experimental arrangement. Although a system of magnetic quadrupoles is shown, these could be replaced with a similar system of electric quadrupoles. The system shown in Fig. 1 can be regarded as an astigmatic lens followed by two astigmatic lenses rotated at 90° to the first lens, and then this combination followed by a fourth astigmatic lens rotated another 90° from the second pair of lenses.

The purpose of this report is to show the results of measurements of the magnetic field in the region of the beam axis, and to show the results of measurements of the trajectories of charged particles entering parallel to the axis.

To satisfy the strong focusing requirements, the geometry was selected so that $dB_x/dy = dB_y/dx = k$. To achieve this, the pole tips were made of mild steel with a rectangular hyperbolic cross section, 2-1/2 in. wide and 4 in. long as shown in Fig. 3. The magnet yokes were made of mild steel and have a 14-1/2 in. inner diameter, a 16-1/2 in. outer diameter, and are 4 in. long. Each pole tip was wound with 200 turns of no. 8 square copper conductor, glass insulated and air cooled. The "radius" of the lens is 1 in. between the beam axis and the vertex of each hyperbola.

MAGNETIC FIELD MEASUREMENTS

The magnitude of the magnetic field was measured in the x, y plane at various distances along the z axis of Fig. 1. To facilitate measurements lucite templates were made so that a coil of bismuth wire could be inserted in a cylindrical hole, Fig. 4.

The results of measurements made along the asymptotic lines, of the hyperbola are shown in Figs. 5 and 6. The magnetic intensities along the contours of the hyperbola are shown by Figs. 7 and 8. The magnetization curve measured at a distance of 1 in. below the axis on the asymptotic line V is shown by Fig. 9.

From the graphs, it can be observed that the "strong focusing" requirements are satisfied to an accuracy that is at least as good as the magnetic measurements, i. e. ± 2 percent for values of B greater than 750 gauss. The magnitude of the field at the axis was too small to measure accurately using the bismuth wire technique.

The magnitude of the stray magnetic field between lenses has been measured. It was observed that for a current of 30 amps/coil and with a separation of 3 in. between lenses, the magnitude of the field along the line through the vertex of the hyperbolas, and midway between lenses is 14 ± 4 percent of the field intensity at the vertex. The field goes to zero in a plane that passes through the axis and is at 45° to the planes through the vertices.

The magnetic field at the midpoint of the line through the vertices is 20 ± 4 percent of the field intensity at the vertex for a current of 30 amps/coil and a separation of 2 in. between lenses. When extensions $1/2$ in. long were added to the hyperbolic pole tips, the field at the corresponding point was 43 ± 4 percent of the field intensity at the vertex.

MEASUREMENTS OF CHARGED PARTICLE TRAJECTORIES

The deflected wire technique ^{ref 2} was used for determining the "trajectory" of charged particles through the system of lenses. The lenses were mounted with the common axis horizontal and the asymptotic lines between poles vertical and horizontal. A horizontal reference plane of bakelite was inserted near the axis and a 1.5 mil diameter copper wire was inserted along the axis. The wire was stretched over a 90° pulley and placed in tension T by a 5.5 gram weight. When the quadrupole magnets were excited and a current i was

Tough
the
wire
is
stretched

passed through the 1.5 mil wire, the wire was deflected to a position equivalent to that of a particle of charge e , velocity v , and momentum $H\rho$ satisfying the relation $H\rho = T/ev$. If H is expressed in gauss cm, T in dynes, then $ev = i$, the current through the wire in abamperes.

A convenient method of satisfying the condition that a particle will come to a focus at an arbitrary point F , Fig. 1, is to fix the position of the wire at the point F and then adjust either the current in the magnets, or the current in the wire, or both, until the wire is deflected in the desired direction at the entrance to the system of lenses.

Figure 10 is a plot of the focusing magnet current required to focus particles of the indicated momenta entering parallel to the axis, at a distance of $f = 1-1/2$ in. and $f = 27.2$ in. from the exit of the last lens.

It is observed that with 15 amps/coil, a 10 Mev proton or a 140 Mev electron entering parallel to the axis is brought to a focus at a distance of $1-1/2$ in. from the exit of the last lens. Also, a 35 Mev parallel beam of protons is brought to a focus at a distance of 27.2 in. with 480 watts power dissipated in the magnets.

A convenient method of estimating the "astigmatism" of the system is to adjust the magnet current to a constant value, fix the position of the wire at the desired focal point, and adjust the current through the flexible wire so that the wire is parallel to the axis in the field free space, before entering the system of lenses. A plot is given by Fig. 11 showing the current required in the flexible wire such that the wire will be parallel to the axis. The diagram for the entire quadrant is shown in Figs. 12 and 13.

The trajectory of the particles through the system of lenses is shown by Figs. 14 and 15. Protons of 7.6 Mev energy entering parallel to the axis, from the right are brought to a focus at a distance of $1-1/2$ in. beyond the exit of the last lens, when the gradient is 2000 gauss per inch. The spacing between vertices of the rectangular hyperbolas is 2 in., radius of 1 in., and particles $3/4$ in. off the axis are brought to a focus, even though their maximum excursion is $1-1/8$ in. from the axis.

OPERATION WITH CHARGED PARTICLES

The system was operated as indicated in Fig. 1 with 460 Kev protons incident parallel to the axis and focused at a distance of $f = \frac{G}{2} = 1-1/2$ in. beyond the exit of the last lens. It was observed that a magnet current of 3 amperes/pole

was required to focus the beam, in agreement with the value of 2.9 amperes given in Fig. 10 as determined by the flexible wire technique. The entrance beam was observed with a grid of 1 mil diameter parallel tungsten wires separated $1/32$ in., and was adjusted to have a $1/2$ in. diameter. The beam was focused on a quartz disc which became incandescent and the spot diameter could be made less than 1 mm. The "grain" structure of the quartz, and charging up of the quartz was a limit to this technique.

The lenses were then connected so that alternate poles, both axially and azimuthally were made to alternate in polarity. The magnet current necessary to focus parallel rays at $f = 1-1/2$ in. was then observed to be 13.1 amperes/pole. At a distance of $f = 8$ in., the optimum focus was observed at 8.9 amperes/pole with a considerable amount of astigmatism.

Two of the lenses were then used to focus the 20 Mev deuteron astigmatic beam from the 60 in. cyclotron. It was possible to increase the current density by greater than a factor of 30 by this system of lenses.

COMPARISON WITH CALCULATIONS

Dr. Lloyd Smith⁴ has formulated a convenient matrix method of solving the equation of motion of the charged particles through a series of lenses. When these equations are transformed to apply to the NSSN combination of Fig. 1, the calculated magnetic field gradient necessary to focus parallel rays of 11 Mev protons at a distance of $f = G/2 = 1-1/2$ in. is 3700 gauss/inch.

The measured field, using the flexible wire technique is 2500 gauss/inch. However, with this type of magnet, the leakage field between adjacent lenses is also useful in focusing the charged particles. Magnetic measurements indicated that the effective length of each lens was approximately 5 in. or 25 percent greater than the geometrical length. To agree with the calculated gradient, the effective length of each lens must be 6 in. Thus, the agreement is only fair.

Next, considering the NSNS combination of lenses the magnetic field gradient required to focus 11 Mev protons that enter at a point focus $1-1/2$ in. before the first magnet and are focused $1-1/2$ in. after the last magnet is 12,500 gauss/inches. Assuming in each case that the effective length of each lens is the same as the geometrical length, the ratio 12,500 divided by 3700 is 3.4. The measured value of field gradient for 450 Kev

protons compared for the two above combinations of lenses is 2100 divided by 550 or 3.8. The agreement is again fair since no attempt has been made to take into account the leakage field between lenses.

ACKNOWLEDGMENTS

The mechanical design of the magnets was done by John Williams. The applications to the 60 in. cyclotron were carried out by Gerhard Fischer. Discussions with Drs. Lloyd Smith and David Judd have been very helpful. Many of the magnetic measurements have been made by a group working with Dr. Harry Keller.

REFERENCES

1. Courant, E. C.; Livingston, M. S.; Snyder, S.; Phys. Rev. 88, 1190, (1952).
2. Blewett, J. P.; Phys. Rev. 88, 1197, (1952).
3. Nunan, C.; University of California Radiation Laboratory Report No. UCRL-2117.
4. Private Communication.

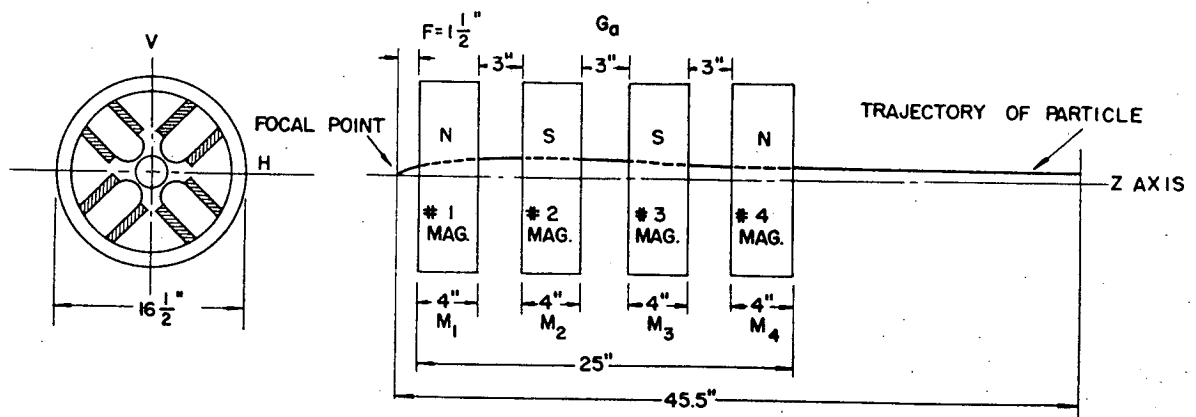

MU-5461

Fig. 1

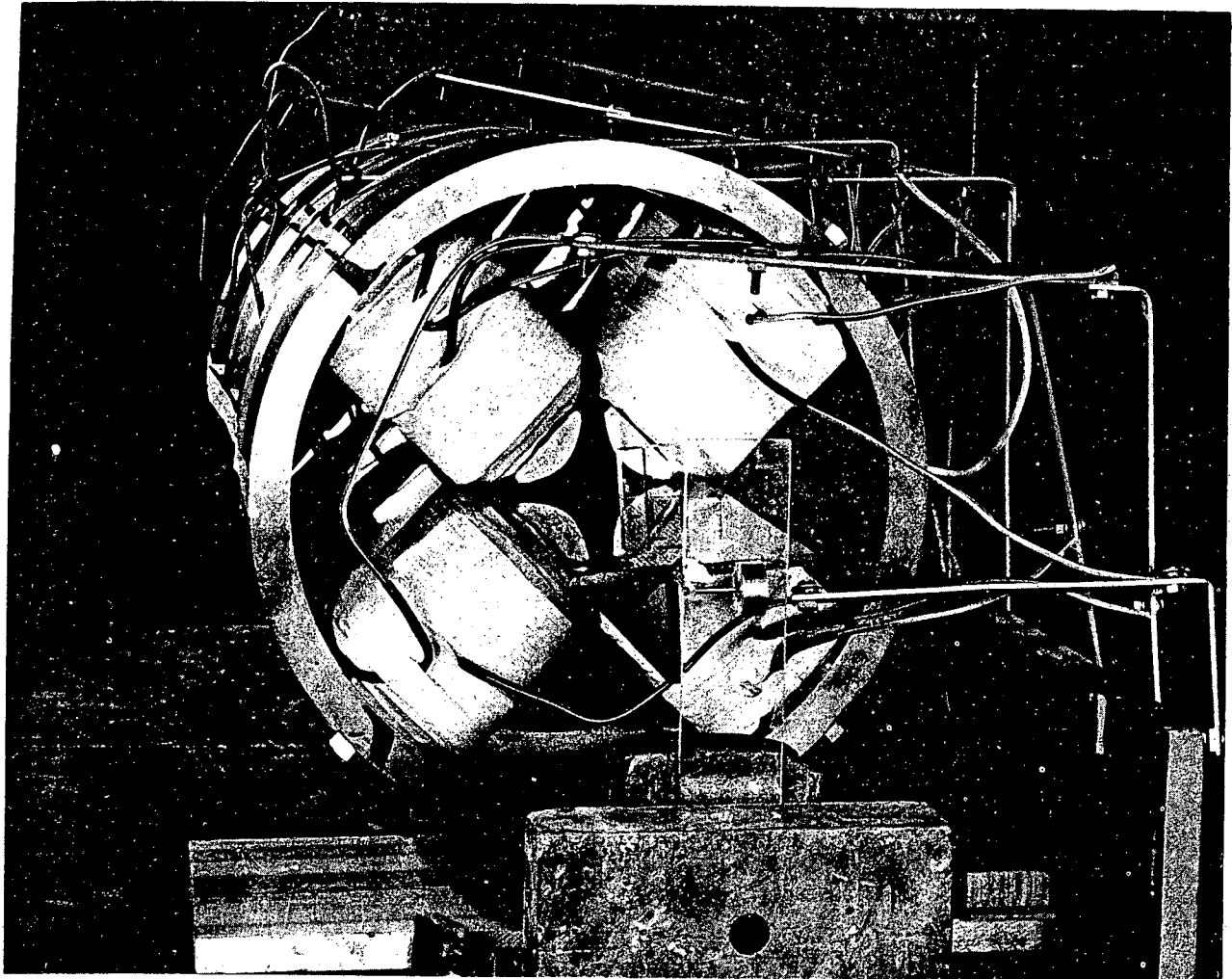

ZN-581

Fig. 2

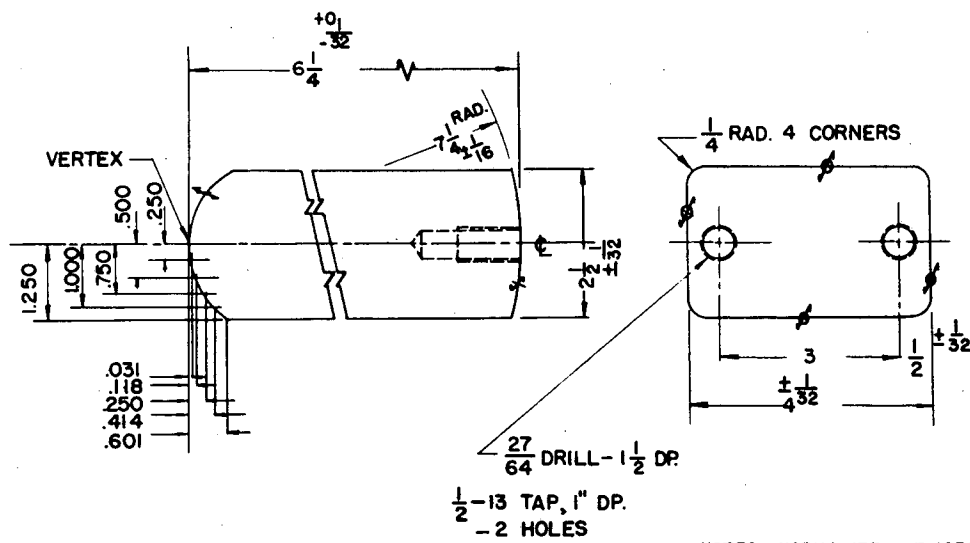

NOTES: NORMALIZE AT 1650-1750° F FOR
 2½ HOURS & AIR COOL

HALF SCALE

MU-5462

Fig

QUADRAPOLE FOCUSsing MAGNET
 TEMPLATES FOR MAGNETIC MEASUREMENTS

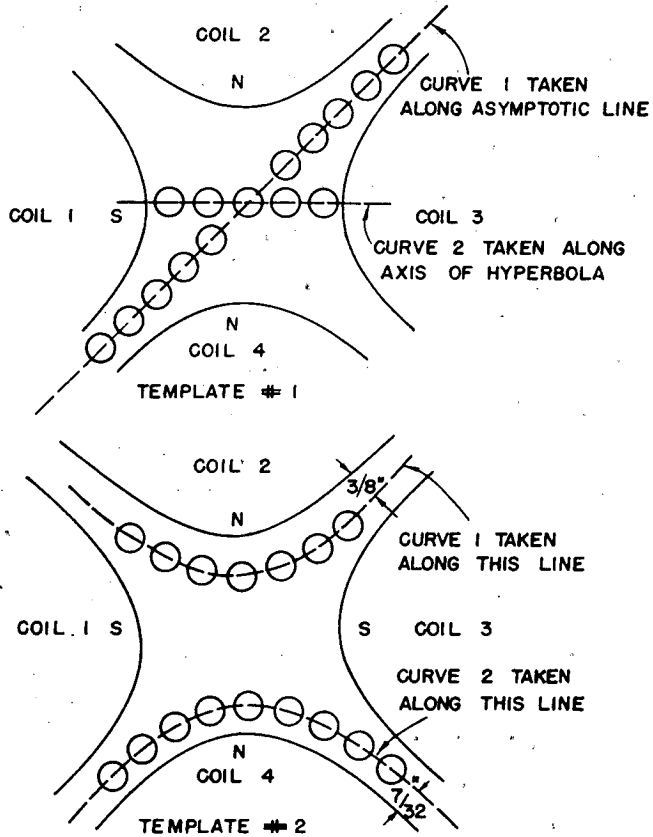

MU-5463

Fig. 4

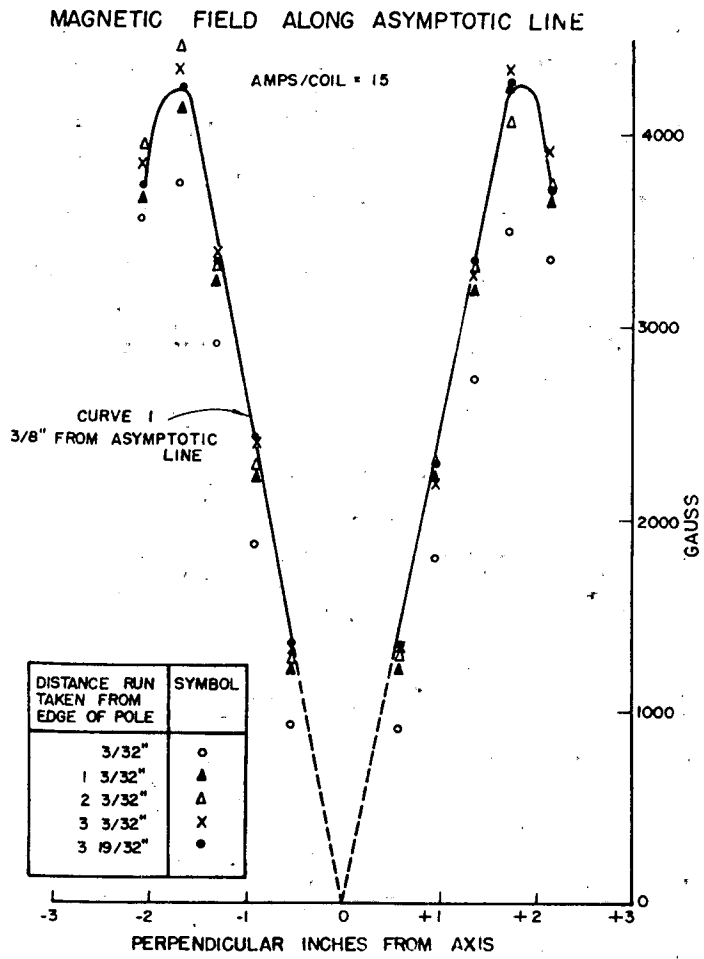

MU-5464

Fig. 5

MAGNETIC FIELD ALONG THE ASYMPTOTIC LINE

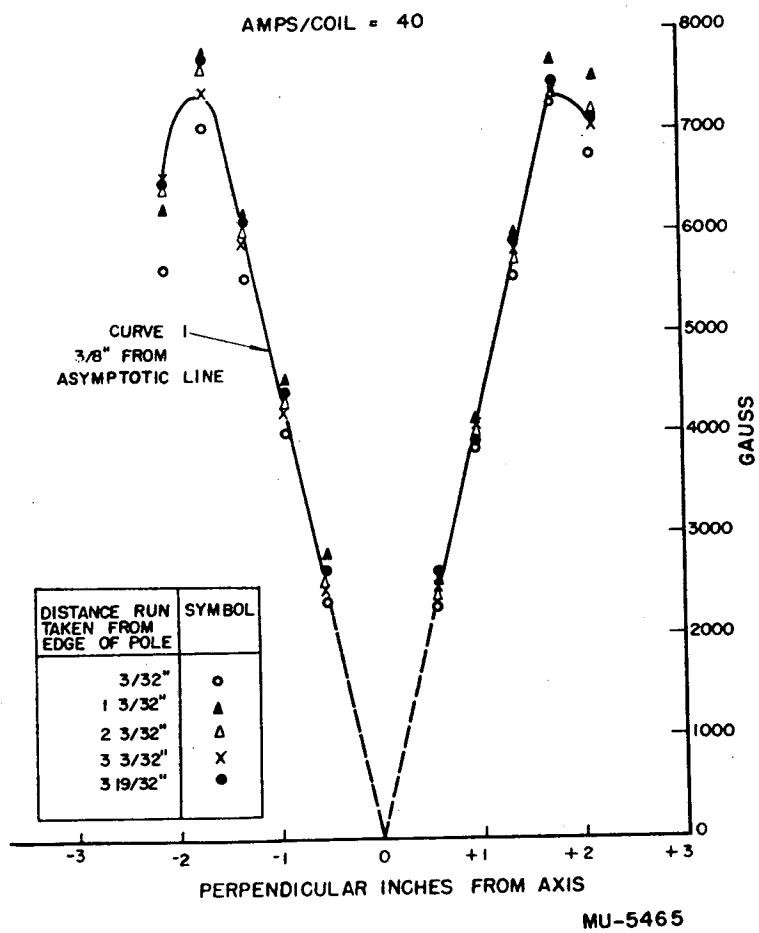

Fig. 6

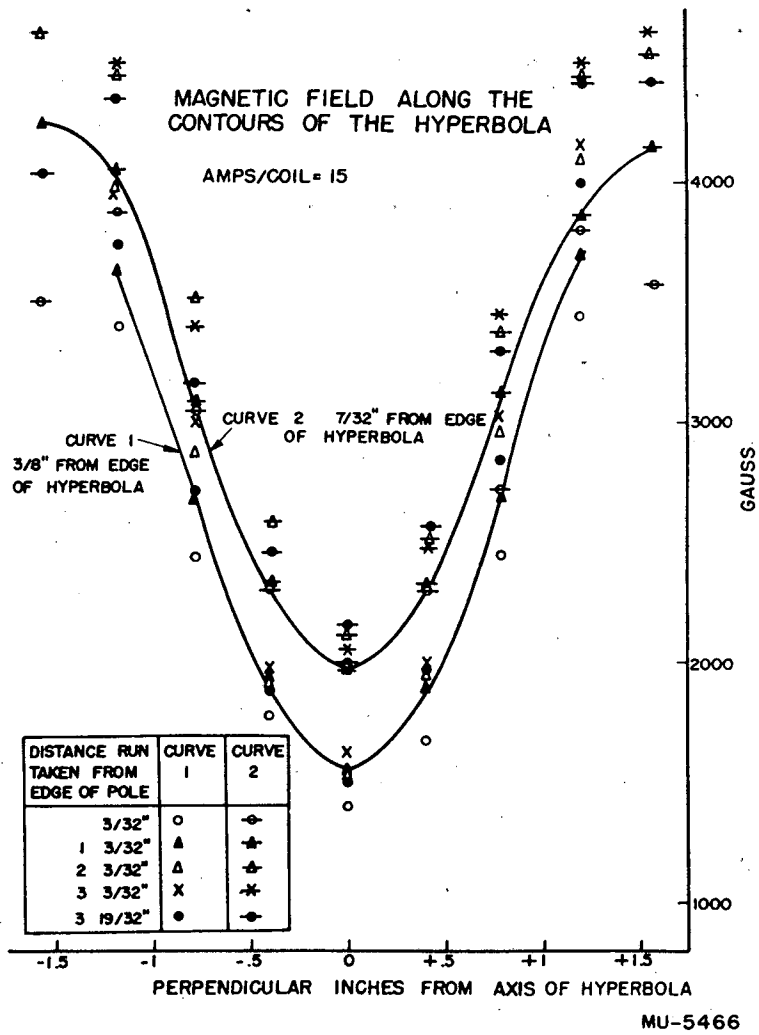

Fig. 7

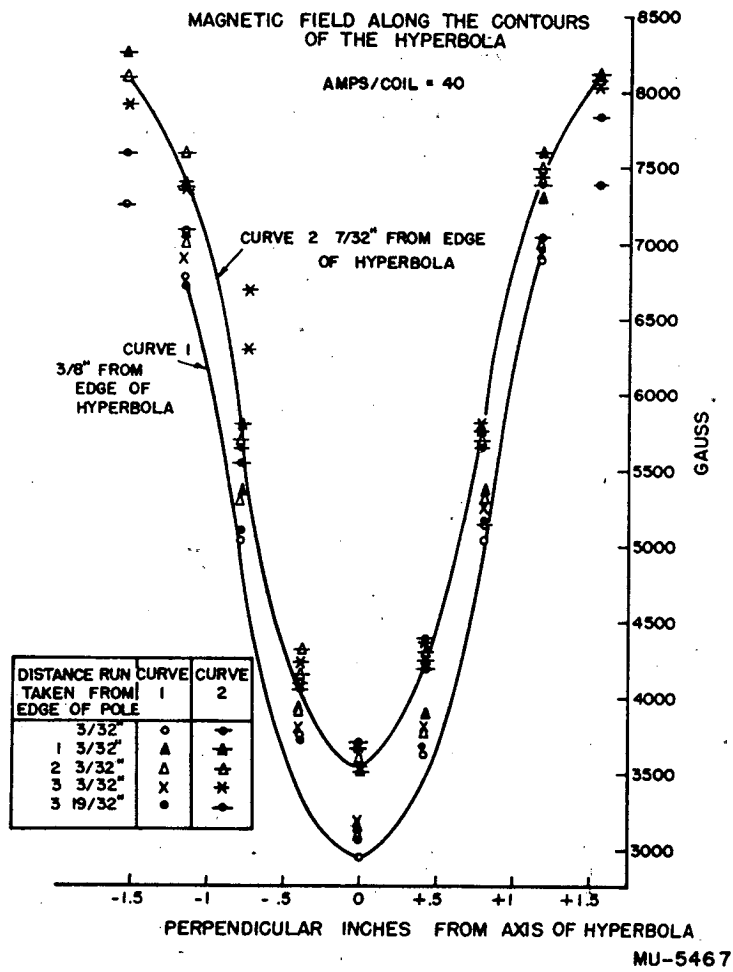

Fig. 8

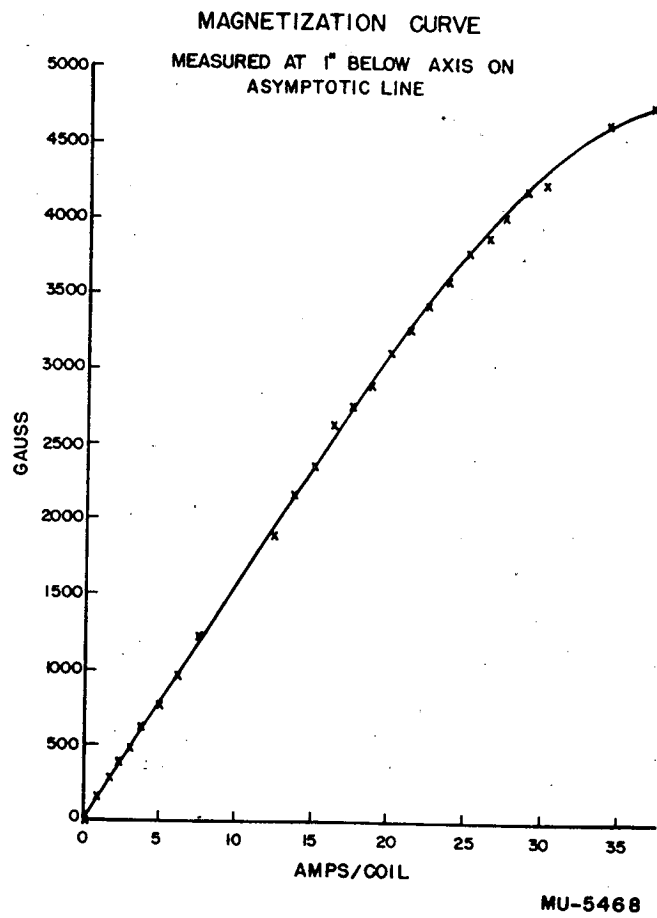

Fig. 9

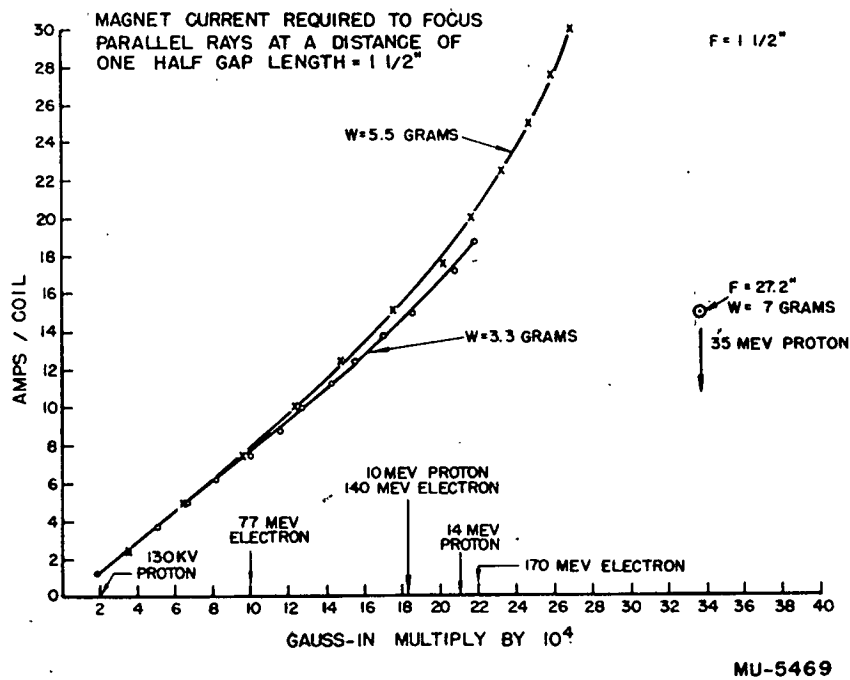
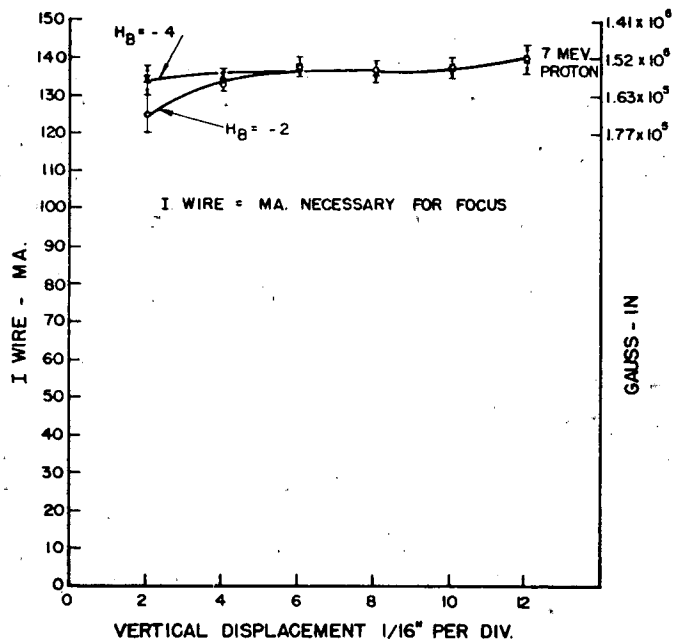

Fig. 10

F = 1/2"
AMPS = 12.5
COIL

THE "MOMENTUM" OF PARTICLES ENTERING PARALLEL
TO THE AXIS & FOCUSED AT A DISTANCE OF 1 1/2"
BEYOND THE EXIT



MU-5470

Fig. 11

WIRE

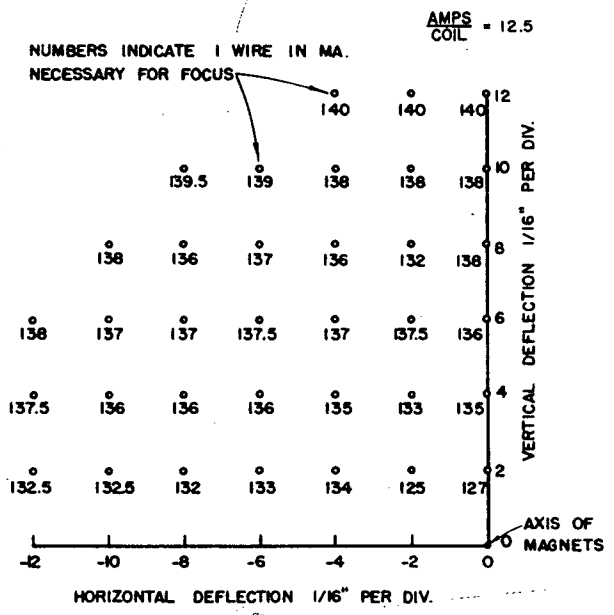

140 MA. EQUIV. TO 1.52×10^7 GAUSS-IN OR 7 MEV PROTON

THE MOMENTUM OF PARTICLES ENTERING PARALLEL TO THE AXIS & FOCUSED AT A DISTANCE OF 1 1/2" BEYOND THE EXIT.

MU-5471

Fig. 12

Wire

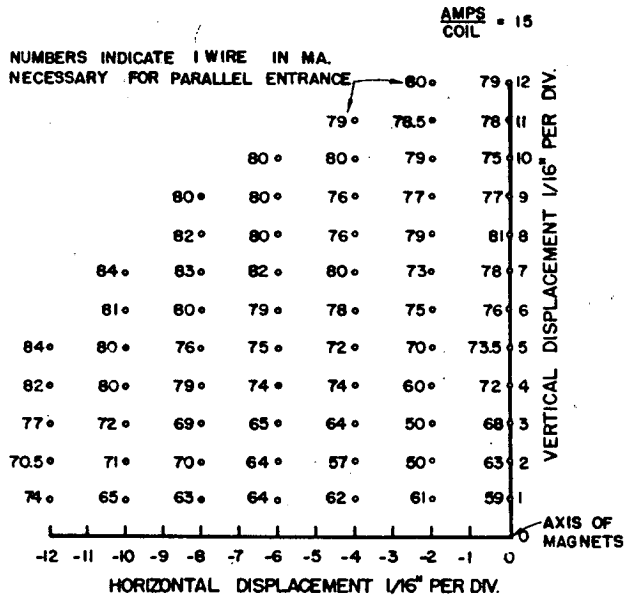

80 MA EQUIV. TO 3.37×10^5 GAUSS-IN OR 35 MEV PROTON

THE MOMENTUM OF PARTICLES ENTERING PARALLEL
TO THE AXIS & FOCUSED AT A DISTANCE OF 272"
BEYOND THE EXIT

MU-5472

Fig. 13

"TRAJECTORY" OF 7.6 MEV PROTONS ENTERING
 PARALLEL TO THE AXIS FROM THE RIGHT
 VERTICAL PLANE, INITIALLY DEFOUSSING

$F = 1\frac{1}{2}"$

$\frac{\text{AMPS}}{\text{COIL}} = 12.5$

7.2 - 8 MEV PROTONS

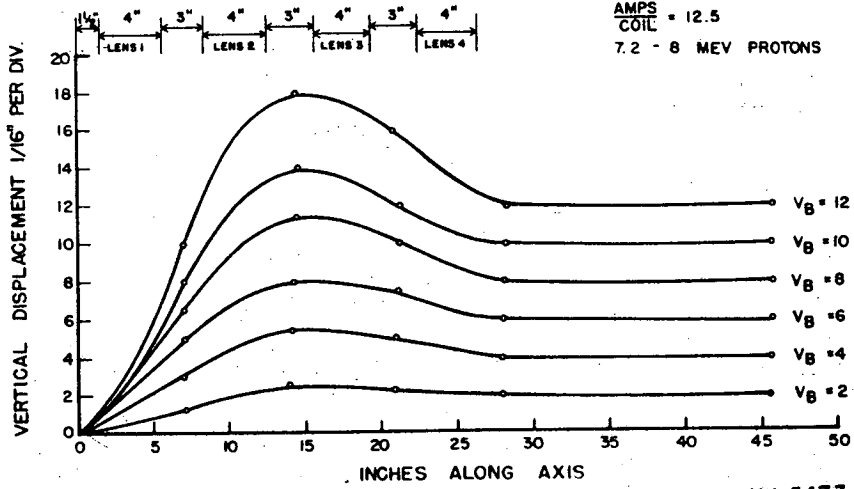

MU-5473

Fig. 14

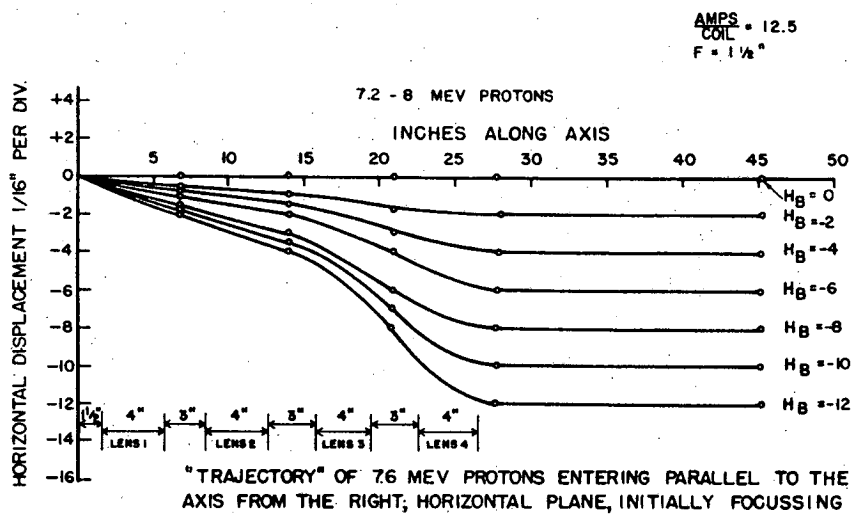

MU-5474

Fig. 15