

Lawrence Berkeley National Laboratory

Recent Work

Title

MULTIPLANE TOMOGRAPHIC GAMMA-RAY SCANNER

Permalink

<https://escholarship.org/uc/item/9z28682k>

Author

Anger, Hal O.

Publication Date

1968-06-01

University of California Ernest O. Lawrence Radiation Laboratory

TWO-WEEK LOAN COPY

*This is a Library Circulating Copy
which may be borrowed for two weeks.
For a personal retention copy, call
Tech. Info. Division, Ext. 5545*

MULTIPLANE TOMOGRAPHIC GAMMA-RAY SCANNER

Hal O. Anger

June 1968

RECEIVED
LIBRARY
RADIATION LABORATORY

Berkeley, California

JUL 22 1968

LIBRARY NO
DOCUMENTS SECTION

UCRL-18338
C.2

DISCLAIMER

This document was prepared as an account of work sponsored by the United States Government. While this document is believed to contain correct information, neither the United States Government nor any agency thereof, nor the Regents of the University of California, nor any of their employees, makes any warranty, express or implied, or assumes any legal responsibility for the accuracy, completeness, or usefulness of any information, apparatus, product, or process disclosed, or represents that its use would not infringe privately owned rights. Reference herein to any specific commercial product, process, or service by its trade name, trademark, manufacturer, or otherwise, does not necessarily constitute or imply its endorsement, recommendation, or favoring by the United States Government or any agency thereof, or the Regents of the University of California. The views and opinions of authors expressed herein do not necessarily state or reflect those of the United States Government or any agency thereof or the Regents of the University of California.

For IAEA Symposium on
Medical Radioisotope Scintigraphy,
Salzburg, August 6-15, 1968

UCRL-18338
Preprint

UNIVERSITY OF CALIFORNIA

Lawrence Radiation Laboratory
Berkeley, California

AEC Contract No. W-7405-eng-48

MULTIPLANE TOMOGRAPHIC GAMMA-RAY SCANNER

Hal O. Anger

June 1968

MULTIPLANE TOMOGRAPHIC GAMMA-RAY SCANNER

Hal O. Anger

Donner Laboratory and Lawrence Radiation Laboratory
University of California, Berkeley, California

June 1968

ABSTRACT

With this new instrument, high resolution over a wide range of depths is combined with the high sensitivity of conventional large-crystal gamma-ray scanners. In contrast to conventional scanners, which produce a single picture having sharpest resolution at the geometric focal plane of the collimator, this new scanner will produce five or more pictures which sharply resolve activity near five or more planes spaced at intervals throughout the organ being scanned. In each picture, activity lying on or near a selected plane is shown in sharp focus, while activity lying at other depths is superimposed but blurred, as in x-ray tomography.

The instrument applies principles from the scintillation camera to focused-collimator gamma-ray scanners. It consists essentially of a gamma-ray image detector as used in the scintillation camera (except for having a thicker scintillator and a smaller number of phototubes), a focused collimator, and a special optical readout camera. While the gamma-ray image detector scans the subject in the same manner as a conventional rectilinear scanner, the film in the optical readout camera scans in synchronism. By the use of several lenses with graded focal lengths, five or more pictures, each resolving a different plane within the subject, is obtained from a single cathode-ray tube display of the photopeak scintillations occurring in the image detector. A digital memory and display system can be used in place of the optical readout camera to obtain both visual displays and numerical data.

INTRODUCTION

This report describes a new type of radioisotope scanner that provides high sensitivity in combination with high resolution over a wide range of depths in the subject. It achieves this by combining radioisotope camera principles with rectilinear scanning and a new readout method.

The new instrument simultaneously produces several picture readouts, each of which is focused on a different plane through the subject. One of the readouts is identical to that obtained from conventional large-crystal scanners. The additional readouts sharply resolve activity at specified planes above and below the geometric focal plane, something that conventional scanners cannot do. Conventional focused-collimator γ -ray scanners image radioactivity on the geometric focal plane of the collimator with high resolution, but activity lying on other planes is superimposed but blurred [1,2]. This effect is more pronounced in scanners with large crystals and short-focal-length collimators [3,4]. The result has been to give a tomographic effect when it was not desired. Conventional scanners with 8-inch crystals have such a narrow depth of focus that they are considered to be unsatisfactory for thick organs such as the liver [4]. With the new multiplane scanner, a tomographic or laminographic series is obtained from a single rectilinear scan. The results are similar to those obtained by taking a series of scans by means of a conventional large-crystal scanner with the γ -ray detector set at different heights above the patient. This latter procedure is so time-consuming that it is seldom used in practice. The new instrument, however, produces a series of pictures focused at equally spaced intervals throughout the subject from a single rectilinear scan. Lesions at any depth in thick organs are sharply resolved on at least one of the pictures, and furthermore, the depth of a lesion is indicated indirectly by the picture that shows it with the best resolution.

The tomographic effect being discussed in this paper is "longitudinal tomography" as first described by Kuhl and Edwards [5]. It should be distinguished from "transverse tomography" in which images are formed from intersecting lines [5,6]. In transverse tomography, activity above and below the specified plane is excluded from the pictures. However, in longitudinal tomography, activity that is off the specified plane is superimposed but blurred in each picture.

MULTIPLANE TOMOGRAPHIC SCANNER

The multiplane tomographic scanner has a conventional focused

collimator and a sodium iodide crystal, 8-1/2 inches in diameter and 1 inch thick, viewed by seven 3-inch-diameter phototubes, as shown in Fig. 1. This γ -ray image probe, as it is called, scans the subject in conventional rectilinear fashion. The scintillations occurring in the sodium iodide crystal are reproduced on a CRT (cathode-ray tube) by the same type of phototube array and computing systems used in the scintillation camera [7,8]. In this latter instrument, both the position and brightness of each scintillation are determined by analog computation from the output signals of the phototubes. The tubes are 2 to 4 cm from the scintillator, so that the light from each scintillation divides among them. From the relative amount of light received by each tube, the position of each scintillation is computed. Also the brightness of each scintillation is computed by adding the output signals from all the phototubes, and then pulse-height selection is used so that only photopeak scintillations are reproduced on the CRT. The principle of operation of the scintillation camera is described in detail in Ref. [8].

As a first step in describing the principle of operation of the new instrument, consider the response of a focused collimator to a point source at 25 different locations, as shown in Fig. 2. With a source at point 1 on plane A, a small area at the left of the scintillator is irradiated. At point 3, the central area is irradiated, and at point 5, an area at the right is irradiated. If a source moves from point 1 to point 5, the irradiated area moves from left to right across the scintillator. If a source moves from point 6 to point 10 on plane B, the same thing occurs except that the source is outside the response zone of the collimator until it reaches point 7, and then the irradiated area moves more rapidly across the scintillator. The irradiated area is somewhat larger than in the previous case. At plane C, the geometric focal plane of the collimator, a source located at point 11, 12, 14, or 15 is again outside the response zone, but at point 13 the entire scintillator is irradiated. At planes D and E, an irradiated area again moves across the scintillator, but it now moves in the opposite direction to the source--namely, from right to left across the scintillator.

OPTICAL READOUT OF MULTIPLE PLANES

The optical readout camera is shown in Fig. 3. For reading out five different planes in the subject, two single lenses of different focal lengths, an aperture plate, and two image-inverting triple-lens systems are used. The lenses, aperture plate, and CRT are stationary, but the photographic film moves in rectilinear fashion in synchronism with the γ -ray image probe. The scanning speed of the film must bear a certain relationship to the scanning speed of the probe, as described later.

In Figs. 4 and 5, the readout process is considered in detail. Point sources 1, 2, and 3 are assumed to be located on planes A, C, and E as shown in Fig. 4a and b. As the γ -ray image probe scans over these sources, the series of displays shown in Fig. 4c is reproduced on the CRT. Five scan lines are shown. Source 1, located close to the collimator on plane A, appears in 25 of the displays. Source 2, located on the geometric focal plane, appears in only one display, since the response zone of the focused collimator is very narrow at its focal plane. Source 3, located far from the collimator on Plane E, appears in 25 of the displays. From the set of CRT displays shown in Fig. 4c, any number of readouts can be obtained, each focused on a different plane through the subject.

First, consider the readout produced by aperture plate C, which con-

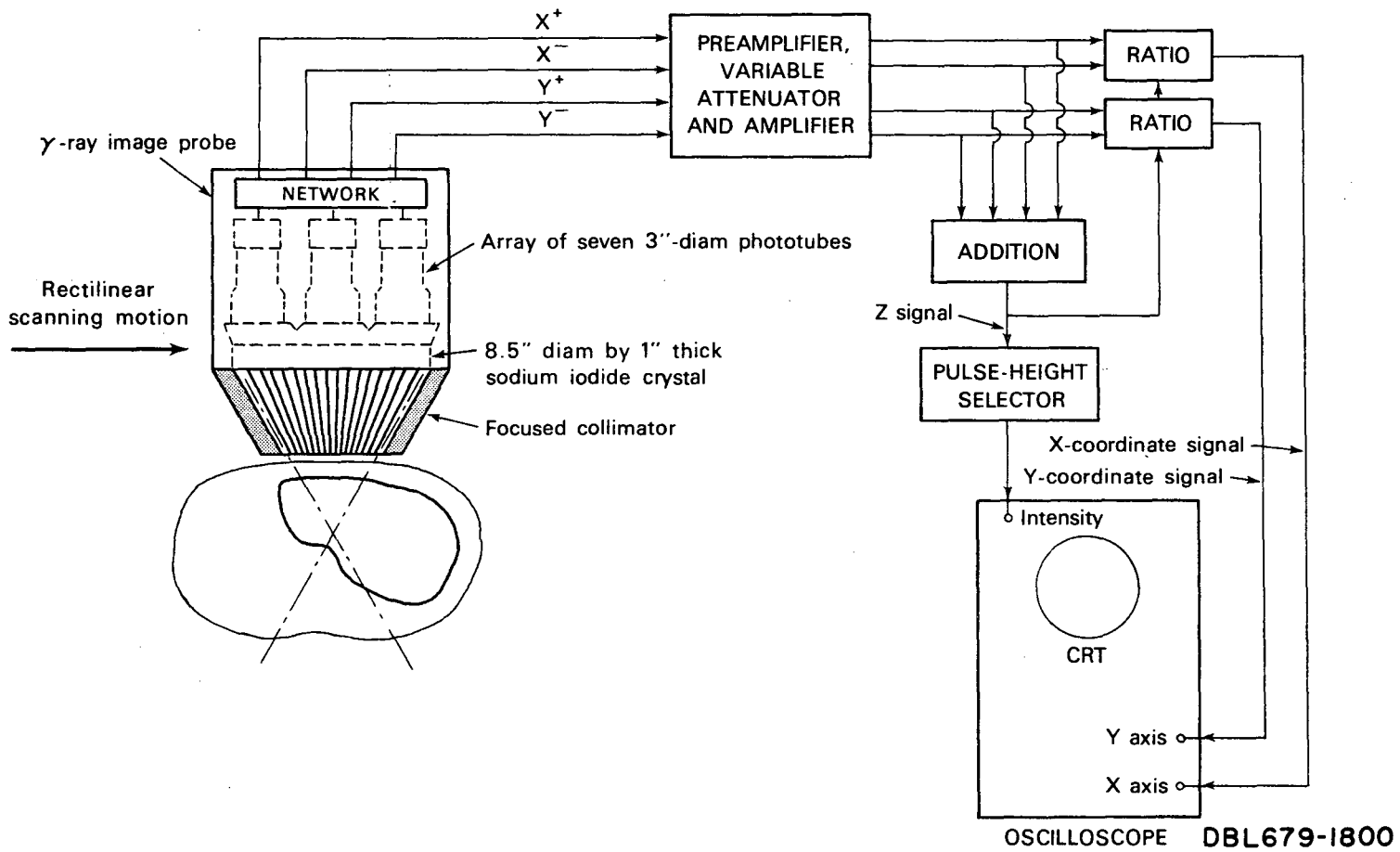
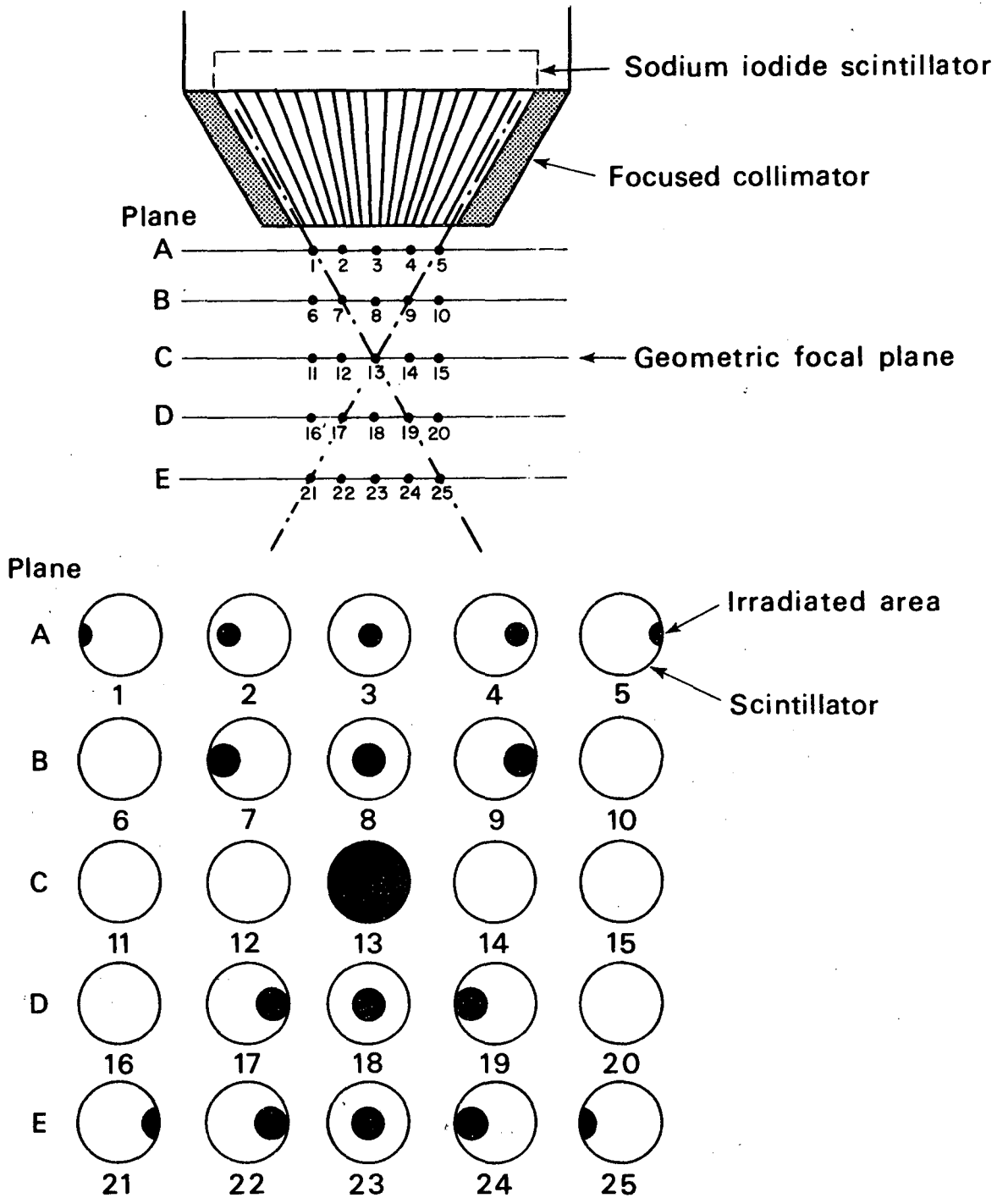
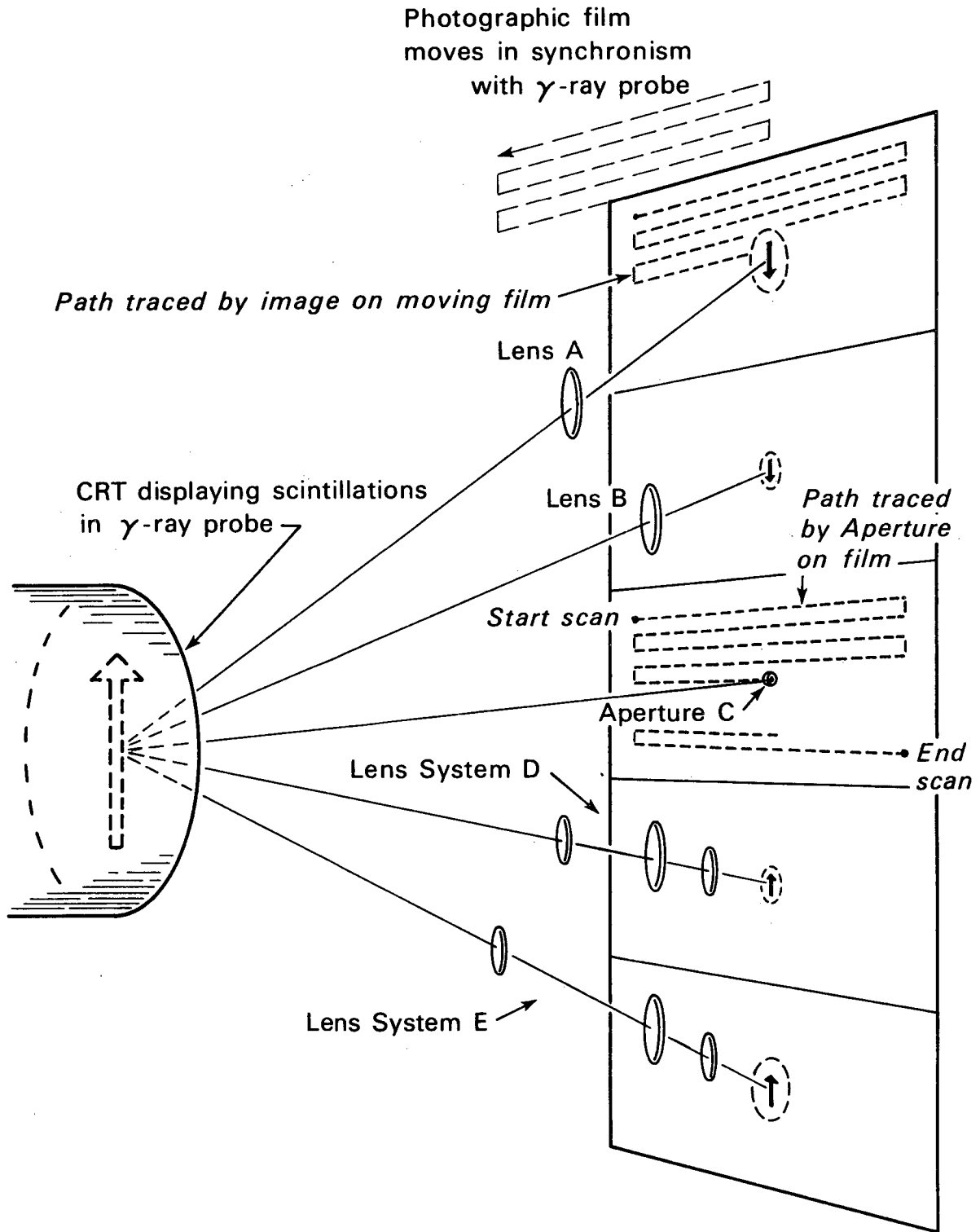

Fig. 1. Block diagram of γ -ray image probe and electronic system for reproducing scintillations in sodium iodide crystal on cathode-ray tube, as in a scintillation camera. Probe scans subject in conventional rectilinear fashion. Readouts focused on several planes in subject are obtained by use of optical readout camera (Fig. 3) or computer system (not shown).



DBL 679-1796

Fig. 2. Scintillator areas irradiated through focused multichannel collimator by point source at 25 different locations. Entire scintillator is irradiated from point 13 at geometric focus. At other points, limited areas of the scintillator are irradiated as shown.



DBL 686-4767

Fig. 3. Diagram of optical readout camera for obtaining five simultaneous readouts, each focused on a different plane in the subject. Two single lenses of different focal lengths, one aperture plate, and two image-inverting triplet lenses are used. CRT and lenses do not move. All readouts are recorded on one sheet of photographic film that moves in rectilinear fashion in synchronism with γ -ray image probe.

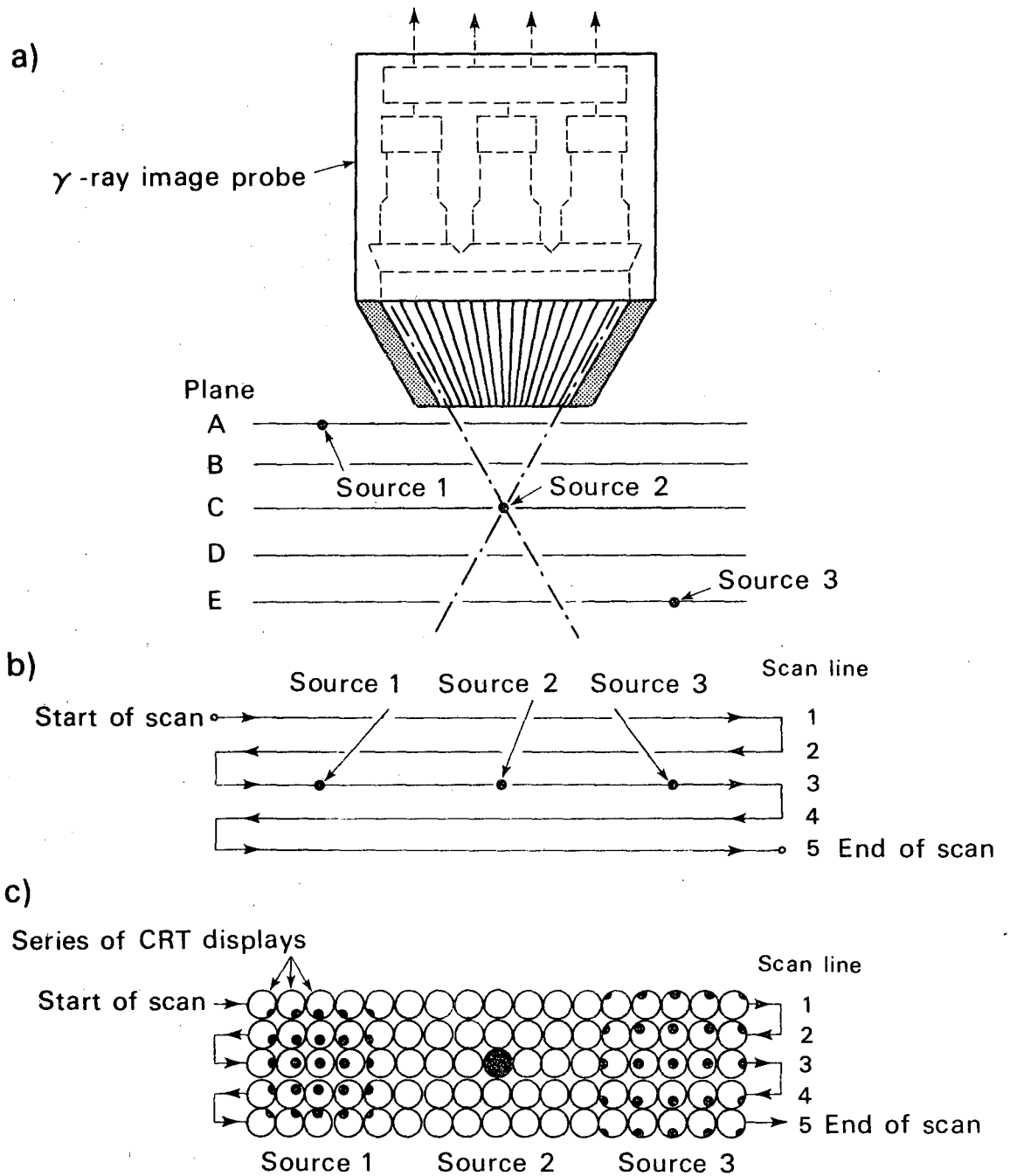

DBL 679-1795

Fig. 4a. Three radioactive point sources on planes A, C, and E. b. Motion of γ -ray image probe during scan, as seen from above the probe. c. Series of displays reproduced on CRT during scan. Arrowheads indicate time sequence of displays.

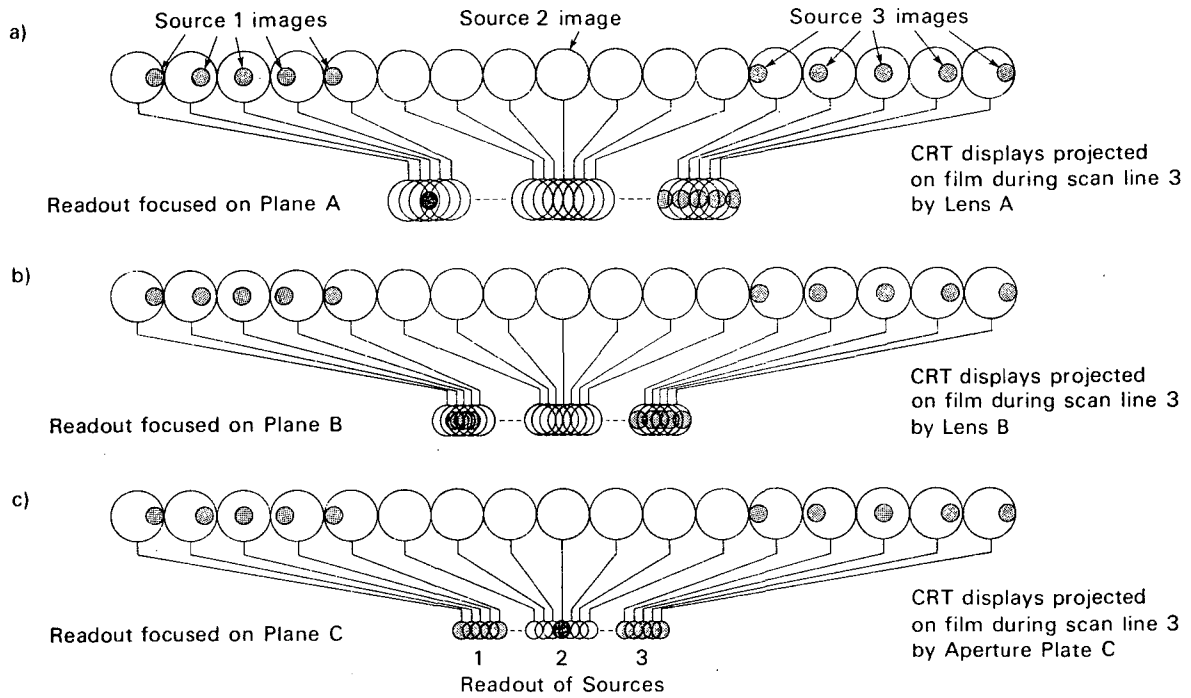

D04, 687-5504

Fig. 5. Graphic illustration of scintiscan readout of sources shown in Fig. 4, as produced by (a) lens A, (b) aperture plate C, and (c) lens system E in optical readout camera. Series of circles at top represent images displayed on CRT during line 3 of scan in Fig. 4c. Series of small overlapping circles immediately below show area of film exposed by each series of images. Note at left of (a), for instance, that all source 1 images expose the same small area of film. This is because the speed of movement of the film is equal to the movement of source 1 projected on the film by lens A. However, the image of source 3 at right of (a), as projected on the film, does not travel at the same speed (it is moving in the wrong direction), and consequently a large area of film is exposed by this source in this readout and an out-of-focus image of source 3 results.

sists of a small hole in a plate that is placed almost in contact with the photographic film. As the γ -ray image probe scans the subject, the film under the aperture plate moves in synchronism, and flashes of light appearing on the CRT expose the small area of film under the aperture. In this readout, the same small area of film is exposed regardless of where the flashes appear on the CRT. The sequence of events occurring during line 3 of the scan is shown in Fig. 5c. The series of circles at the top represent the series of images displayed on the CRT. The series of small circles below represent the areas of film exposed through the aperture plate as the film moves. Source 2 is sharply resolved in this readout, because scintillations from this source appear on the CRT display for only a short time, namely, when the focused collimator is aimed right at the source, and because the aperture is very small. Sources 1 and 3 are not sharply resolved on this readout, because they appear on the CRT for a longer time, as indicated by their appearance in five of the CRT displays in Fig. 5c.

Furthermore, as shown in Fig. 4c, counts from sources 1 and 3 appear in adjacent scan lines 1, 2, 4, and 5, as well as in scan line 3. Therefore, the readout of sources 1 and 3 is spread out both at right angles and parallel to the scan line direction. The complete readout obtained from aperture plate C is shown in Fig. 6c. The readout is identical to that obtained from a conventional scanner. It is focused on the geometric focal plane of the collimator, and the overall resolution of activity on all planes is not better or worse than that from a conventional 8-inch scanner with the same collimator.

Next consider the readout obtained from lens A in Fig. 3. This readout will be focused on plane A, which is very close to the collimator. As the γ -ray image probe scans across source 1, the irradiated area from the source moves across the scintillator and across the CRT display, as illustrated at the left of Fig. 4c and also in Fig. 5a. The CRT flashes projected on the photographic film by lens A also move, and furthermore, if the image projected on the film is the proper size, the flashes move in the same direction and with the same speed as the film. Therefore, all of the flashes from source 1 are recorded on the same small area of film. Thus, source 1 on plane A is read out on the film with high resolution. In the adjacent scan lines 1, 2, 4, and 5, the image of source 1 is superimposed on the same film area as in line 3, because the image of the source is displaced either upward or downward in adjacent scan lines, as shown at the left of Fig. 4c.

In this same readout, source 2 appears only briefly in scan line 3, but at this time, the flashes cover the entire CRT screen. The image of the CRT projected on the film by lens A is relatively large compared with the area of film exposed through aperture plate C in readout C, and the result is a blurred image of source 2.

In the same readout, source 3 is imaged on only a small area of the CRT, but its direction of movement on the film is opposite to that of source 1 in both the horizontal and vertical directions. Therefore, the CRT flashes are spread over a wide area of film both horizontally and vertically and the result is a very blurred image of source 3. The complete readout by lens A of the three sources is shown in Fig. 6a.

If a source were located on plane B, the flashes would move more rapidly across the CRT during the scan than sources located on plane A. Therefore, to obtain a readout focused on plane B, a smaller image of the

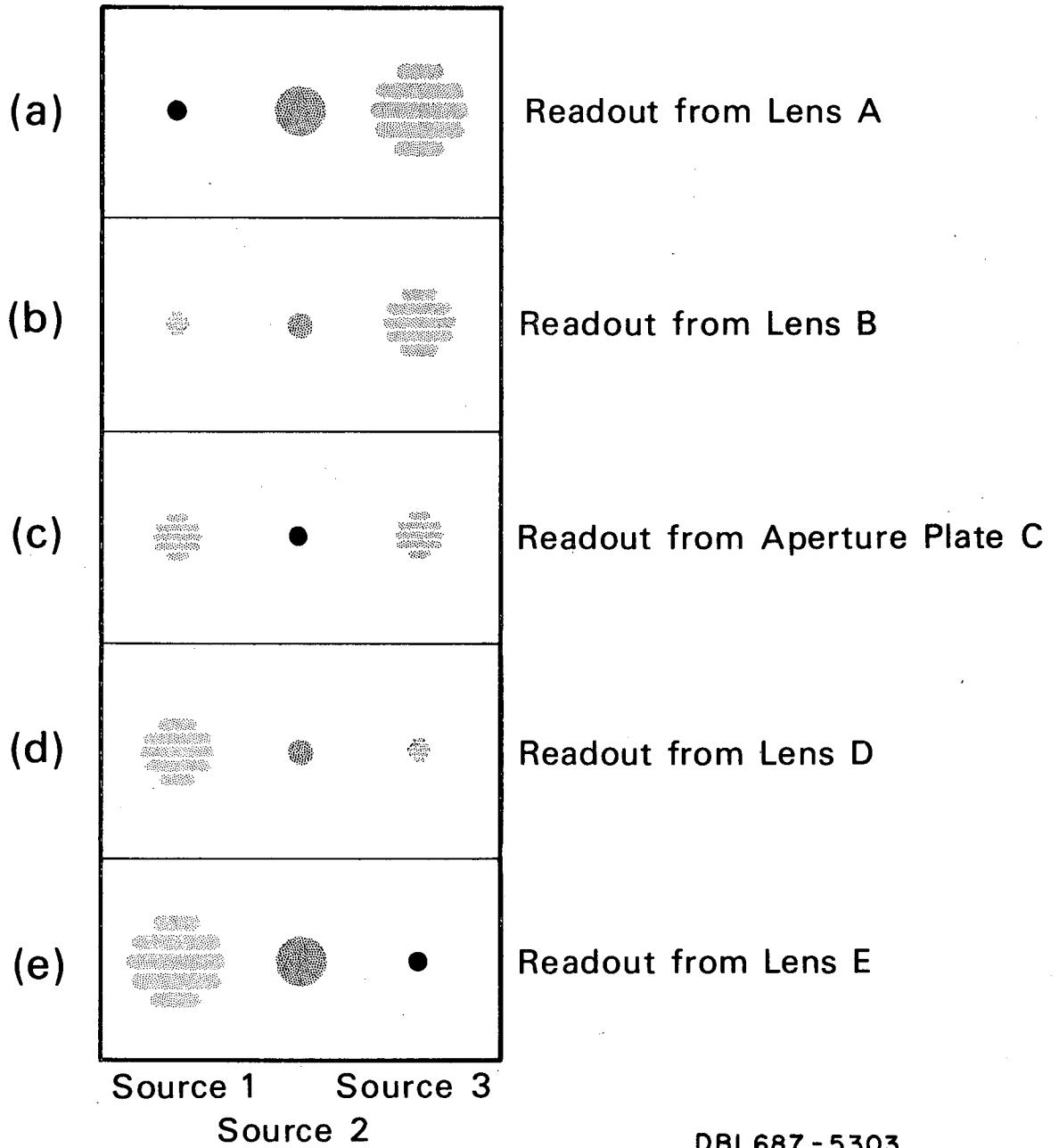

Fig. 6. Five-plane scintiscan readout of the three sources shown in Fig. 4. All are obtained from the optical readout camera during a single rectilinear scan of the subject.

CRT display is projected on the film by lens B in Fig. 3 in order to synchronize the movement of sources on plane B with the movement of the film. The smaller image size is easily obtained from a lens with a shorter focal length.

For readout of planes D and E, which are below the geometric focal plane of the collimator, the same sizes of images are used as for planes B and A, respectively, but the images are inverted and reversed right to left by the use of a triple-lens system. Reference to Fig. 2 or Fig. 4c shows that for sources on these planes, the irradiated area on the scintillator travels in the opposite direction to that of sources located above the geometric focal plane. Therefore, inverting lens systems are used for readout of planes D and E to make the projected images of sources on these planes stationary with respect to the moving film.

A graphic representation of the five scintiscan readouts of the three sources is shown in Fig. 6. Source 1 is sharply imaged in the readout from lens A, source 2 is sharply imaged in the readout from aperture plate C, and source 3 is sharply imaged in the readout from lens system E. The depth of a source can be determined by noting which readout shows it most clearly.

In mathematical terms, for the activity on a given plane to be read out with maximum resolution, the relationship between the γ -ray image-probe scanning speed S , the film scanning speed S' , and the diameter D of the CRT display image projected on the film is expressed as

$$D = \frac{2S'}{S} (f-b) \tan \frac{\alpha}{2}. \quad (1)$$

The focused-collimator acceptance angle is α , the focal length of the collimator is f , and the distance from the collimator to the readout plane is b . Without any change in scanning speeds or any other parameter, activity on other planes can be simultaneously read out with maximum resolution by projecting CRT images of proper sizes on the film. The size of each image is controlled by the placement and focal length of the lens employed. For $b > f$, D is a negative number, and image inversion is required. When the above parameters are adjusted to provide maximum resolution of plane A, source 1 is represented on the readout by a small intense area whose diameter is equal to that of the irradiated region of the scintillator as projected on the film. Source 2 is represented by an area whose diameter is equal to the CRT image diameter D as projected on the film. Source 3 is represented by an area whose diameter is approximately twice that of the image diameter D . Similar relationships exist in the other scintiscan readouts.

COMPUTER READOUT OF MULTIPLE PLANES

In place of the optical readout system just described, the same images can be stored in computer-type memory systems. Then any of the images can be displayed on a CRT for visual inspection, and numerical data can be extracted by conventional techniques. A proposed method is shown in Fig. 7.

With five complete memory-core systems, the images can be stored as follows. First, x' and y' signals must be generated that indicate the coordinates of the γ -ray scanning probe as it scans in rectilinear fashion over the subject. This can be done by means of potentiometers connected mechanically to the γ -ray probe. The origin of this coordinate system is at the lower left corner of the scan. Second, as γ -rays are detected, a second set of signals,

x'' and y'' , is produced by the γ -ray probe for each detected γ -ray, as in a conventional scintillation camera. The origin of this second coordinate system is at the center of the scintillator in the γ -ray probe. The relationship of these coordinate signals is shown at the top of Fig. 7.

As the probe scans the subject, each scintillation that passes the pulse-height selector will be stored as a single event in each of the five memory core systems. The storage location is different in each memory system, except for the special case in which a scintillation occurs exactly in the center of the scintillator, since x'' and y'' are then zero. The locations at which events are stored are given by

$$\begin{aligned} X &= x' + knx'', \\ Y &= y' + kny'', \end{aligned} \quad (2)$$

where $X = x$ coordinate of stored event in a given memory system,
 $Y = y$ coordinate of stored event in a given memory system,
 k and $n =$ constants whose values determine the distance from the geometric focal plane of the collimator to the various readout planes.

For high-resolution readout of activity on plane C (the geometric focal plane of the focused collimator), $kn = 0$. For this readout, the location at which the detected γ rays are stored depends solely on the location of the γ -ray probe, as it does in a conventional scanner. For high-resolution readout of planes above the geometric focal plane, kn is positive, and for planes below the geometric focal plane, kn is negative. The positions of the scintillations within the γ -ray probe then become relevant, and if the polarity and magnitude of kn are correct, the movement of irradiated areas across the scintillator exactly compensates for movement of the γ -ray image probe.

If k is a constant and n is assigned the values +2, +1, 0, -1, and -2, an equally spaced tomographic series of readouts will be stored in the five memory systems. Giving kn a negative value is equivalent to inverting the image in the optical readout system previously described, and changing the value of n is equivalent to changing the size of the CRT image as projected onto the film.

Numerical counting data can be obtained from selected areas of any of the readouts by conventional techniques. Furthermore, data from one readout may be subtracted from, or otherwise modified by, data from another readout. For instance, if the readout in Fig. 6b were subtracted from the readout in Fig. 6d, source 2 would be eliminated from the resulting difference readout, while sources 1 and 3 would be represented by modified circular functions. All radioactivity lying on plane C would be erased from the difference readout.

CALCULATION OF RESOLVING DISTANCES

The overall resolving distance R_0 for sources on any plane in the subject as shown in a given readout is equal to the vector sum of three components: R_c , the resolving distance of the central channel of the focused collimator alone; R_p , the resolving distance due to the parallax of the collimator channels referred to the particular readout plane; and R_e , the resolving distance of the scintillator-phototube combination referred to the readout plane;
 or

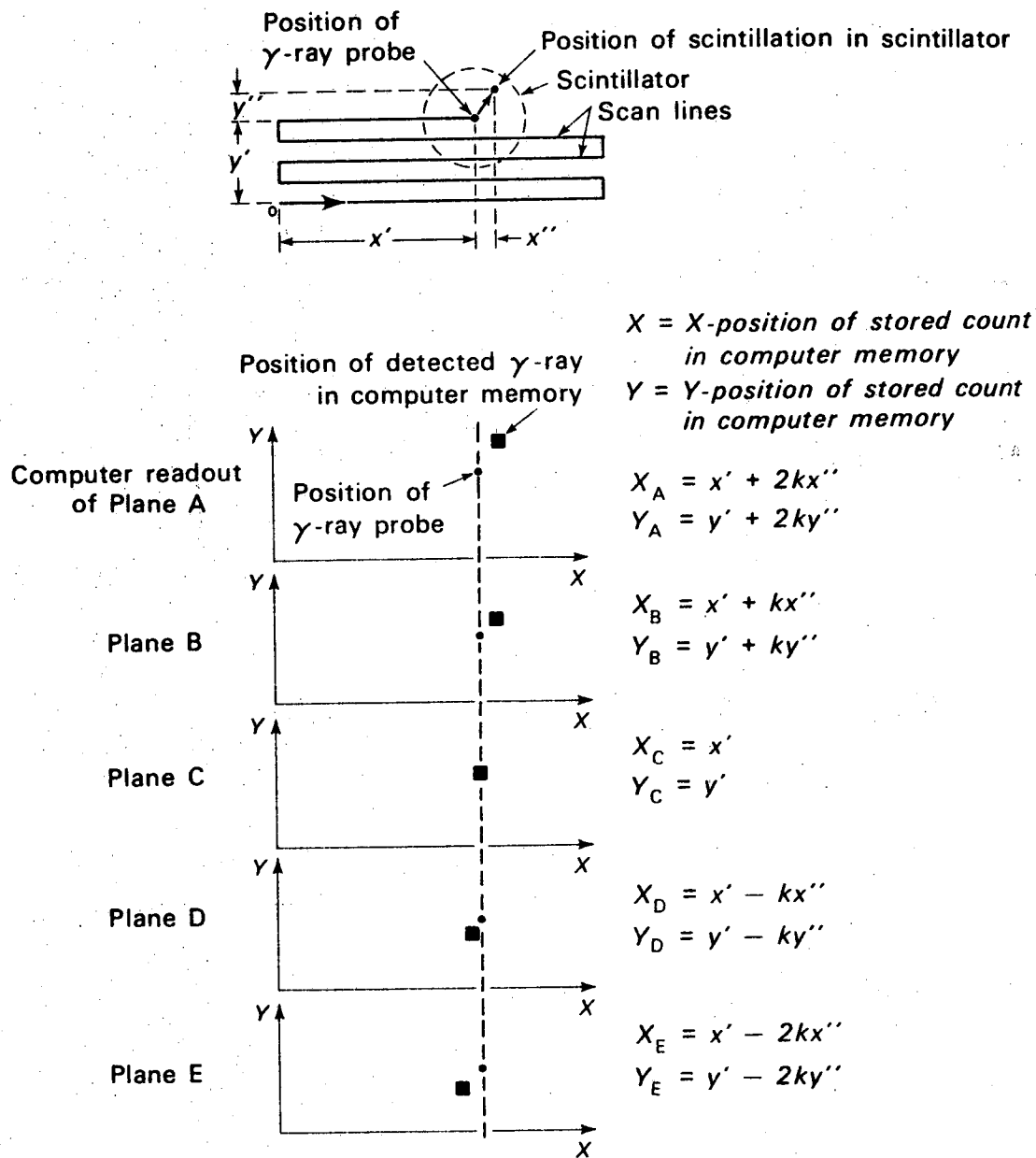

DBL 679-1793

Fig. 7. Rectilinear scan and readout of scintillations into a 5-plane memory system. Coordinates of the γ -ray probe are x' and y' with origin at lower left of scan. Coordinates of scintillation are x'' and y'' with origin at center of scintillator. Coordinates where the event is stored in the five memories are X and Y , computed for the five planes as shown.

$$R_0 = \left(R_c^2 + R_p^2 + R_e^2 \right)^{1/2} . \quad (3)$$

The value of R_p for a given readout plane is given by

$$R_p = \sqrt{Z} (h-b) \tan \frac{\alpha}{2} , \quad (4)$$

where h = distance from collimator to readout plane, and b = distance from collimator to active source. The point-source response function of R_p is rectangular in shape, and its subjective value is taken as $1/\sqrt{Z}$ times the width of the function as suggested by Vetter [9]. The value of R_e is given by

$$R_e = R_i \frac{f - h}{a + c + f} , \quad (5)$$

where R_i = inherent resolving distance of the scintillator-phototube combination,
 c = distance from exit of collimator to the central plane of the scintillator.

For the 5-plane readout system described in this report, R_p for readout planes A through E is represented in Fig. 8 by a family of five curves, while R_c and R_e are each represented by single curves. Readout planes were assumed to be located 2, 5, 8, 11, and 14 cm from the collimator. The geometric focus of the collimator was assumed to be at 8 cm, and its acceptance angle α was assumed to be 70° . An inherent resolving distance $R_i = 2.5$ cm was assumed for the plot of R_e .

The overall resolving distance R_0 is represented in Fig. 8 by a second family of five curves, one for each readout plane. Minimum overall resolving distances of 0.9, 0.9, 0.9, 1.3, and 1.7 cm occur at $b = 2, 5, 8, 11,$ and 14 cm respectively. Every point in the subject between 0 and 15 cm from the collimator is imaged with less than 2 cm resolving distance in one or two of the five readouts.

RESULTS

As this paper is being written, the multiplane tomoscanner has been in operation only a few weeks. It is apparent that excellent resolution is obtained at any depth up to 4 inches from the collimator. The resolution decreases gradually at greater depths.

Scans of a test pattern containing 2 mCi of technetium-99m are shown in Fig. 9. A 10-inch diameter disc source was covered with a pattern of 1/16-inch-thick lead strips that were 1/4, 3/8, 1/2, and 3/4 inch wide separated by lucite strips of the same width. Scans were taken with the source at 1, 2, 3, 4, 5, and 6 inches from the collimator, which was an Ohio-Nuclear Model 8D with 3-1/2-inch focal length and 0.23-inch radius of resolution. A 6-plane optical readout was used in place of the 5-plane system described earlier in this report.

The 1/4-inch bars are clearly resolved at 1, 2, 3, and 4 inches from the collimator. They are barely distinguishable at 5 inches. The 3/8-inch bars are clearly resolved at all distances.

In Fig. 10 is shown a liver scan after administration of 2 mCi of technetium-99m sulphur colloid. The scanning time was 8 minutes and the

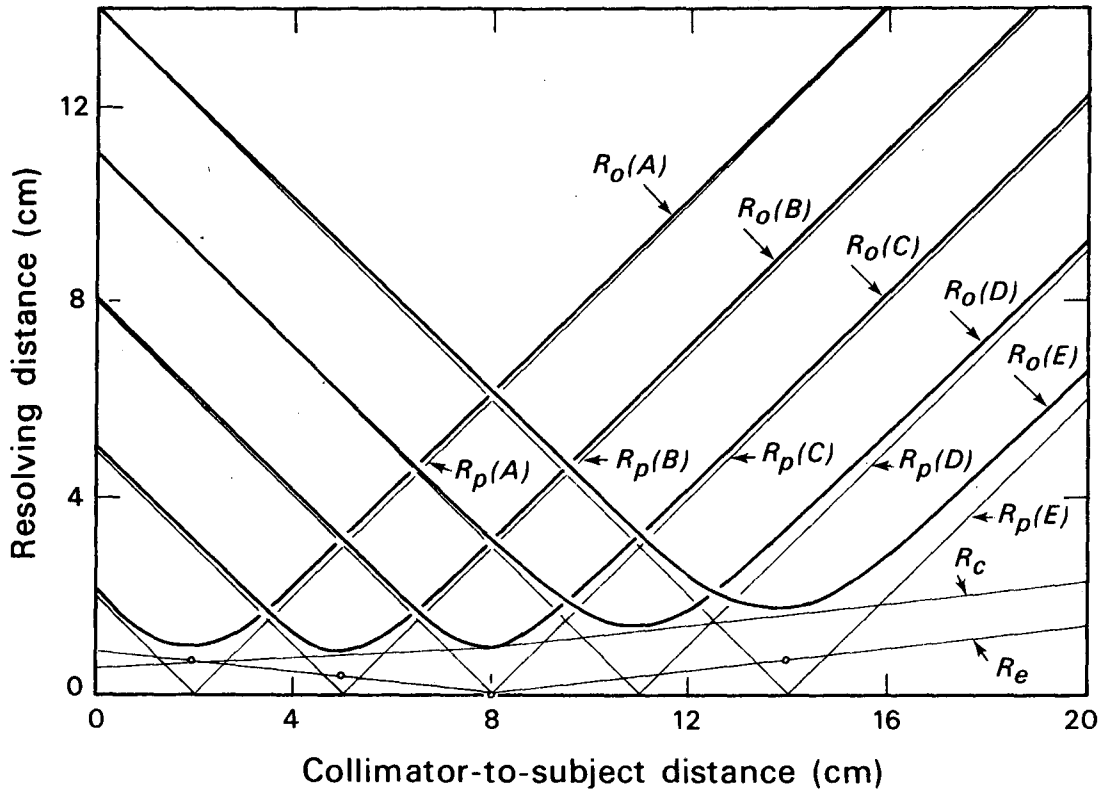

DBL 679-1797

Fig. 8. Expected resolution of tomographic scanner. The five curves labeled $R_0(A)$ through $R_0(E)$ give the overall resolving distance R_0 of five scintiscan readouts corresponding to planes A-E at 2, 5, 8, 11, and 14 cm from the focused collimator. Other curves are the three components of R_0 as described in text.

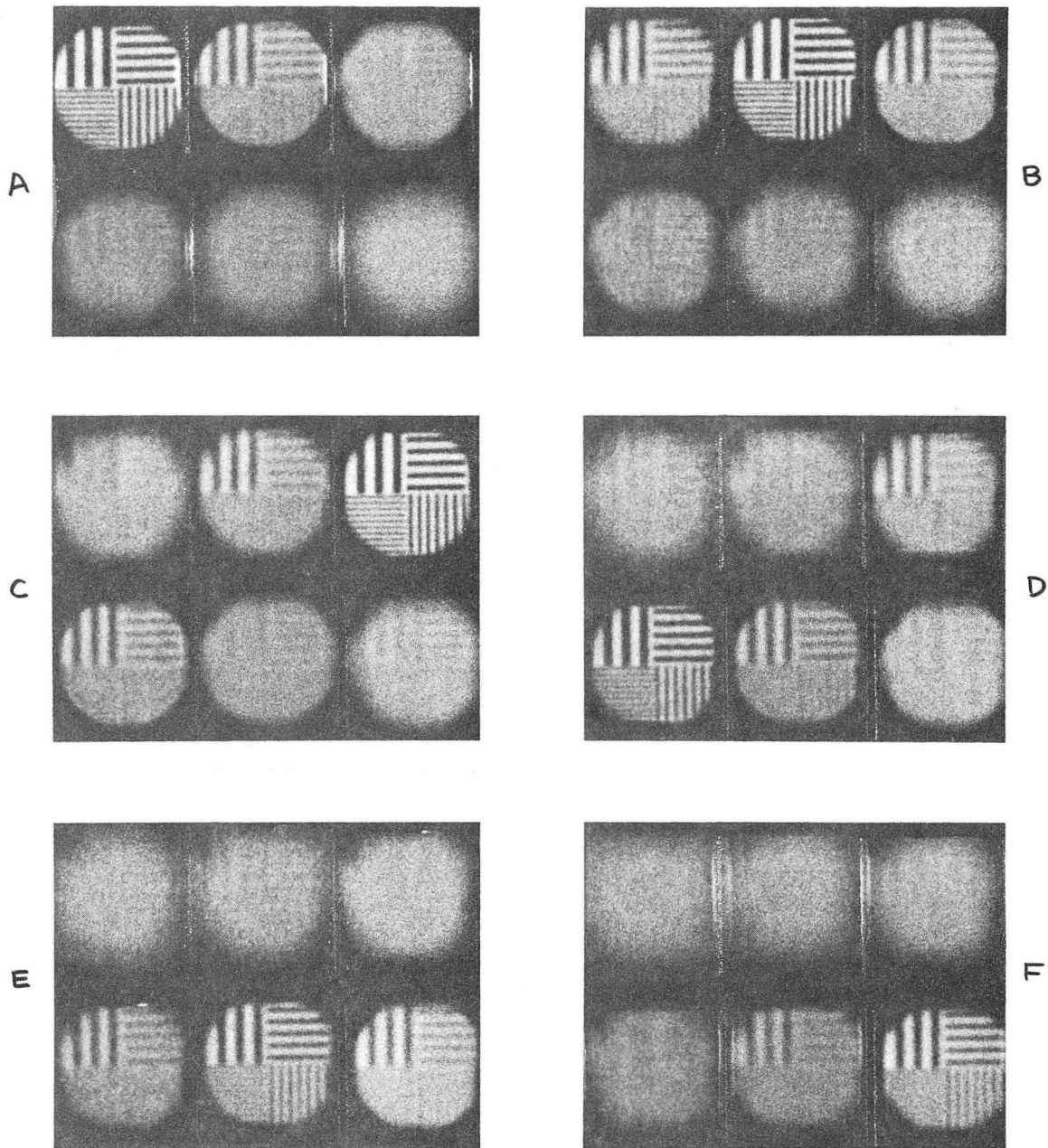

XBB 687-4181

Fig. 9. Series of scans of a test pattern at various distances from focused collimator as described in text. An optical readout system was used as described in Fig. 3, except six lens systems and no aperture plate were employed. Readouts are focused at 1, 2, 3, 4, 5, and 6 inches from collimator.

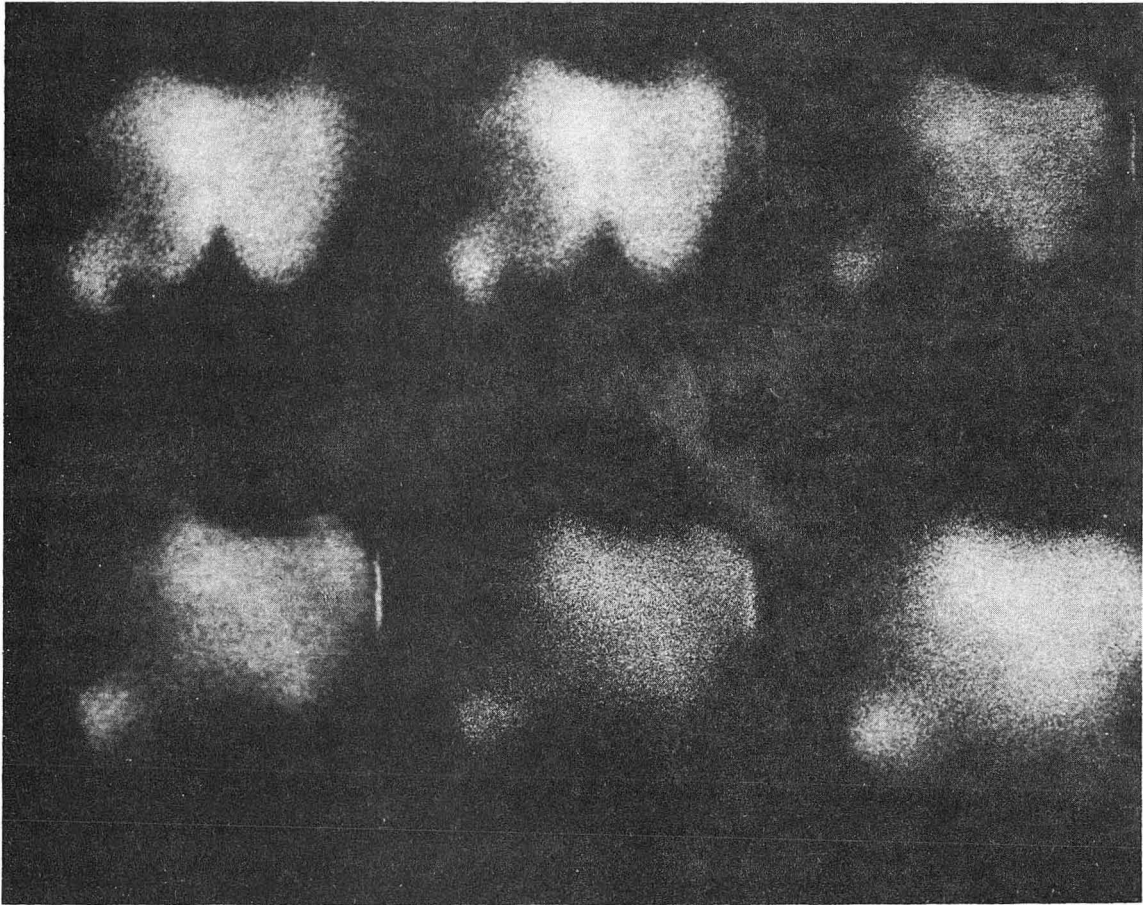

XBB 687-4182

Fig. 10. First scan of a patient. Liver with metastatic lesions is shown after 2 mCi of technetium-99m sulphur colloid was given. Scanning time was 8 minutes.

same collimator was used as in Fig. 9. Examination of the first four readouts shows that various structures and edges are shown most sharply in specific readouts. This was the first patient done on the multiplane scanner.

DISCUSSION

This new approach to radioisotope scanning should improve the clinical results obtained with large-crystal scanners, because it will provide high sensitivity while maintaining high resolution over a wide range of depths. It will also provide a tomographic series of pictures in which the depth of a lesion is indicated by that picture in the series which shows the lesion with sharpest resolution. It will eliminate the need for collimators of extra-long focal lengths for deep-lying organs.

An inevitable question is: How will the tomographic scanner compare with the scintillation camera? Possibly the most important difference is that the tomographic scanner will be limited to static or slow dynamic studies, because, like all scanners, it must mechanically scan over the subject to obtain a picture. In contrast, the scintillation camera can take very short exposures when enough activity is present, because it sees all of the subject continuously.

The overall resolution of the tomographic scanner is better than that of the scintillation camera. In the scintillation camera the inherent resolving distance of the scintillator-phototube combination must be added vectorially to the resolving distance of its collimator. The theoretical result for the 2.2-inch, 0.36-MeV high-resolution collimator [10], if plotted in Fig. 8, would be approximately a straight line between $R_0 = 1.0$ cm at $b = 0$ cm, and $R_0 = 2.6$ cm at $b = 20$ cm. In the tomographic scanner, high inherent resolution in the scintillator-phototube combination is not so important, because the geometry of the focused collimator minimizes the overall effect of inherent resolving distance, as expressed in Eq. (5).

The multiplane scanner should give its best performance with γ rays in the range of 0.2 to 0.5 MeV rather than lower energies, because absorption of the higher-energy γ rays by large amounts of overlying tissue is appreciably less, and because a larger fraction of scattered γ rays are removed by pulse-height selection [11]. Structures located deep in the subject should be more visible than in the example shown in Fig. 10.

ACKNOWLEDGMENTS

This work is supported by the United States Atomic Energy Commission. The work of many people in designing and constructing this instrument is gratefully acknowledged: in particular, Philip E. Yost, Alfred A. Windsor, John R. Gurule, Rollin A. Armer, Victor P. Jensen, and E. F. (Pete) Dowling.

REFERENCES

- [1] BRUCER, M., Radioisotope scanning, ORINS-20 (1958).
- [2] BROWNELL, G. L., Theory of radioisotope scanning, Intern. J. Appl. Radiation Isotopes 3 (1958) 181.
- [3] CASSEN, B., Section scanning with a large solid angle collimator, J. Nucl. Med. 6 (1965) 767.
- [4] McAFFE, J. G., MOZLEY, J. M., NATARAJAN, T. K., FUEGER, G. F., and WAGNER, H. N., Jr., Scintillation scanning with an eight-inch diameter sodium iodide (TI) crystal, J. Nucl. Med. 7 (1966) 521.

- [5] KUHLE, D. E., and EDWARDS, R. Q., Image separation radioisotope scanning, radiology 80 (1963) 653.
- [6] ANGER, H. O., "The scintillation camera for radioisotope localization," in Radioisotope in der Localizationsdiagnostik, (HOFFMANN, G., SCHEER, K., Eds.), F. K. Schattauer-Verlag, Stuttgart (1967). Also in Lawrence Radiation Laboratory Report UCRL-17284 (October 1966).
- [7] ANGER, H. O., Gamma-ray positron scintillation camera, Nucleonics 21 [10] (1963) 56.
- [8] ANGER, H. O., "Scintillation camera with 11-inch crystal," in Biology and Medicine Semiannual Report, Lawrence Radiation Laboratory Report UCRL-11184 (Fall 1963), p. 69.
- [9] VETTER, H. G., Characterization of geometric imaging properties of gamma ray detectors, Intern. J. Appl. Radiation Isotopes 18 (1967) 231.
- [10] ANGER, H. O., Scintillation camera with multichannel collimators, J. Nucl. Med. 5 (1964) 515.
- [11] ANGER, H. O., Radioisotope cameras, in Instrumentation in Nuclear Medicine, (HINE, GERALD J., Ed.) Academic Press, New York (1967), p. 514.

This report was prepared as an account of Government sponsored work. Neither the United States, nor the Commission, nor any person acting on behalf of the Commission:

- A. Makes any warranty or representation, expressed or implied, with respect to the accuracy, completeness, or usefulness of the information contained in this report, or that the use of any information, apparatus, method, or process disclosed in this report may not infringe privately owned rights; or
- B. Assumes any liabilities with respect to the use of, or for damages resulting from the use of any information, apparatus, method, or process disclosed in this report.

As used in the above, "person acting on behalf of the Commission" includes any employee or contractor of the Commission, or employee of such contractor, to the extent that such employee or contractor of the Commission, or employee of such contractor prepares, disseminates, or provides access to, any information pursuant to his employment or contract with the Commission, or his employment with such contractor.

