

# UC Irvine

## UC Irvine Previously Published Works

### Title

Genetic Relations of Polynesian Sibling Terminologies

### Permalink

<https://escholarship.org/uc/item/9vq8n8fs>

### Journal

American Anthropologist, 75(5)

### ISSN

0002-7294

### Authors

EPLING, PJ

KIRK, JEROME

BOYD, JOHN PAUL

### Publication Date

1973-10-01

### DOI

10.1525/aa.1973.75.5.02a00250

### Copyright Information

This work is made available under the terms of a Creative Commons Attribution License, available at

<https://creativecommons.org/licenses/by/4.0/>

Peer reviewed

# Genetic Relations of Polynesian Sibling Terminologies

P. J. EPLING

University of North Carolina, Chapel Hill

JEROME KIRK

JOHN PAUL BOYD

University of California, Irvine

*Relations between anthropology and linguistics are explored through the examination of the taxonomy and phylogeny of a small lexical set (sibling terms) within the Polynesian genetic language/culture unit using traditional and mathematical techniques of historical semantics and ethnology. Preliminary to examination of the Polynesian case a theory of sibling terminologies is developed, building on those of Murdock and of Nerlove and Romney. Beginning with the lattice of all possible partitions of sibling terms, assumptions are developed which reduce the number of terminologies (4140) to a smaller number (146), based on conjunctive concepts. The terminologies of a sample of twenty-three Polynesian languages/cultures are shown to be five of the 146 types. Four of the five types are shown to be adjacent points in an upper semi-lattice of the whole lattice. An evolutionary hypothesis is developed which further reduces the number of evolvable types, from 146 to nineteen for the Polynesian unit. The relation of the evolution of the terminologies and the daughter languages is shown. Likely paths of evolution of the terminologies are suggested. Functional correlates of the types are also examined, and it is concluded that economic features are of great significance in the evolution of sibling terminologies.*

THIS ARTICLE has two main objectives: (1) to present the outlines of a formal theory of sibling terminologies and show how this theory relates and makes additions to the prior theories of Murdock (1968) and Nerlove and Romney (1967); (2) to demonstrate how the theory applies and aids in the explanation of the taxonomy and phylogeny of sibling terminologies of a genetic unit of languages and societies.

## THEORY OF SIBLING TERMS AND TERMINOLOGIES

### *Sibling Terms*

We restrict our consideration of the range of denotation of sibling terms to siblings. That is, we will not consider the classificatory use of "brother," for example, to refer

to parallel cousins. With this restriction, any sibling term can be described by means of three dimensions, or features: age, parity, and sex (of referent, as opposed to sex of speaker). The two values of the sex dimension, male and female, are denoted by m and f. The relative age dimension has values e and y to read elder and younger, respectively.

The dimension we call parity is sometimes confused with a logically independent possible dimension, sex of speaker. The two are, of course, logically equivalent in the case of a primary relationship, but distinct in some instances of descriptive strings. For example, if a sibling terminology has only two terms, one for same sex sibling, and the other for opposite sex sibling, an ambiguity arises for a male speaker in the genitive construction, "my mother's brother." The referent of this string (the uncle) is the same sex as the speaker, but the opposite sex from the

Accepted for publication October 4, 1972

relative (his sister) to whom he is connected by the sibling term. Or, again, in the reflexive statement, "I am the brother of my sister," a terminology which distinguishes parity but not sex of speaker will prescribe the "opposite sex" term for describing the speaker himself.

It has been our experience (in Polynesia especially) that the cross-sex term is used in situations like the above; that is, parity, rather than speaker's sex, is the criterion. We suspect that this is the intended meaning of most descriptions of terms according to sex of speaker, as used by anthropologists and native speakers. Roberts and Schneider (1956) report a sibling terminology for Zuni (Fig. 1) which may stand as a counter-example. If, however, our interpretation is correct, this would be true only for primary relatives, and ego in this system would describe himself as the *janni* of his elder sister. Certainly, we know of no system in which both parity and sex of speaker components co-occur, so that only three dimensions apply in any terminology.

The three dimensions of sibling terminology have been chosen so as to insure that

as many as possible of the observed sibling terms found in the world can be described as the intersection, or conjunction, of values on these dimensions. That is, we find many terms like "elder brother" or "same sex," which can be represented as "em" or "/ /" in our notation. Note that single terms such as "/ /" or "m" can be considered as trivial conjunctions of only one term. It would have been *a priori* just as plausible to replace the parity distinction with one of "sex of connecting relative" in its absolute sense. But the sibling term corresponding to "/ /" would have to be described as the disjunction, "male's male sibling or female's female sibling." The point is that what is conjunctive or disjunctive is entirely dependent upon the set of primitive concepts of the model. The argument for the psychological and social value of conjunctive concepts has been made forcefully enough in other places such as in Bruner, Goodnow, and Austin (1956) so that it is reasonable to accept a conjunctive definition of a concept as a goal in itself.

Since sibling terms are by definition relations, it is not surprising that at some deeper

	♂ SPEAKER		♀ SPEAKER
e	m papa	f Kawu	m papa
y	suwe	likina	Janni

(suwe = my, m. s.)

(likina = fy, m. s.)

(Janni = y, w. s.)

Figure 1. Zuni sibling terminology after Roberts and Schneider (1956).

level of reality, the parity and relative age dimensions are intuitively felt to be "relational" concepts. This relational character need not disturb or concern us here as we shall treat these dimensions as atomic concepts with no reference to their relational aspects.

A natural notation can be given for sibling terms that are conjuncts of values on the three basic dimensions. For example, "//em" denotes a "same sex elder male sibling." Since the sex of the referent is already specified, this can be read "elder brother" and "e" as "elder sibling."

In this notation there are eight possible distinctions to be made on the finest level. They are:

- //em
- //ef
- //ym
- //yf
- xem
- xef
- xym
- xyf

These points are conveniently visualized as the vertices of the unit three dimensional cube, as in Figure 2.

Note that the labeling of the cube is such that the left-right dimension corresponds to parity; the vertical dimension, to age; and the front-back dimension, to sex of referent. A sibling term can be considered as one of the  $2^8 = 256$  subsets of these eight atomic terms. Most of these subsets will not be con-

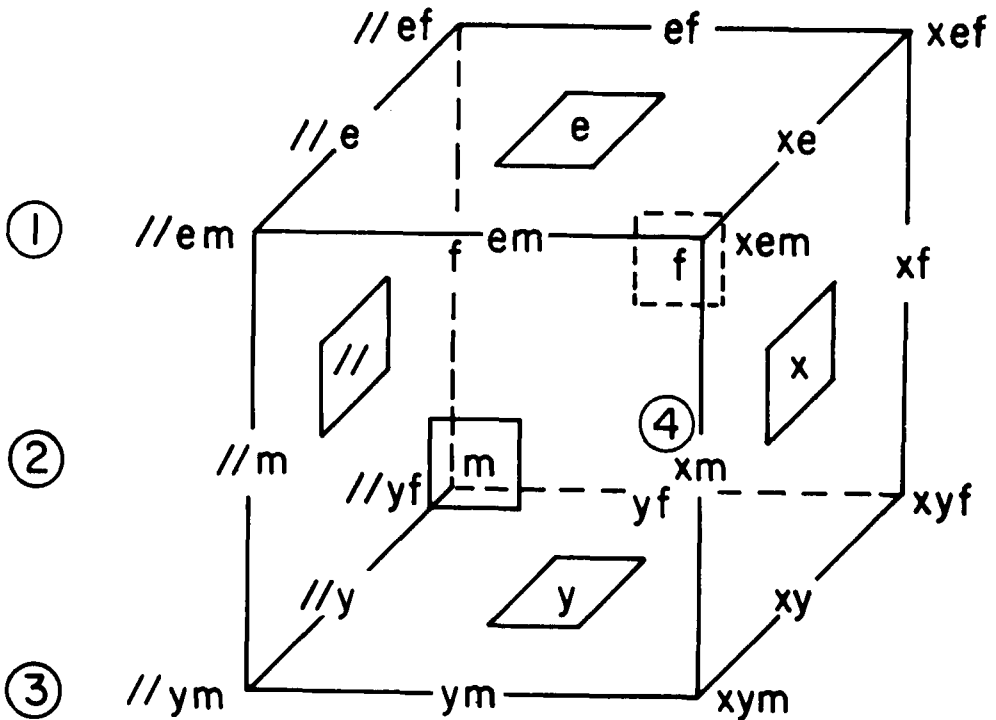

Figure 2. The set of twenty-seven possible conjunctive sibling terms embedded in the three-cube. Each conjunct can be considered as a *subcube*: a vertex, an edge, a face, or the whole three-cube itself.

junctive, as for example, the set  $\{ //ef, xym \}$ . To count the number of conjunctive terms, recall that each conjunct can have one of three values corresponding to parity, namely, “/,” “x,” or a blank; similarly, for the other two dimensions, giving a total of twenty-seven possible conjunctive terms, including the cover term “sibling,” represented by all blanks.

*Sibling Terminologies*

So far only single terms have been considered. One of the objects of our theory is to understand sibling terminologies as complete systems. We define a sibling terminology as a disjoint and exhaustive collection of sibling terms. That is, every one of the eight atomic sibling terms must appear once and only once in this collection. Another way of putting this is to say that a sibling terminology is a *partition* on the set of eight atomic sibling terms. The number of all possible partitions on these eight terms,  $P(8)$ , and therefore of all possible sibling terminologies, is found recursively from the formula:

$$(1) \quad P(m + 1) = \sum_{i=0}^m \binom{m}{i} P(i),$$

with the understanding that

$$P(0) = 1 \text{ and } \binom{0}{i} = 1.$$

$P(8)$ , according to this expression, is 4140, the sample space of the natural experiment of sibling terminologies. Both Murdock (1968, 1970) and Nerlove and Romney (1967) classify extant terminologies within this space.

The lattice of all possible partitions (terminologies,  $\pi$ ), or any sub-lattice, may be taken as the taxonomic space (and by implication, the phylogenetic space) for the sibling terminologies of a given genetic unit.<sup>1</sup> (It should be noted that the rare but interesting “cover” terms—such as the English sibling, which covers both brother and sister—are excluded from consideration by this definition of a terminology.) The phylogenetic question of interest for a particular taxonomy is its evolutionary trajectory and

the social and historical causes of its change over time.

Several useful notations are available for representing terminologies defined in this way. Three of the most commonly used are illustrated and compared in Figure 3. For

- (A)
1. /USO/ = //em or //ef=//e
  2. /TUAGANE/ = xef
  3. /TUAFAFINE/ = xem
  4. /TEI/ = //ym, //yf, xym, xyf=y

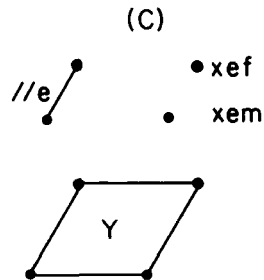
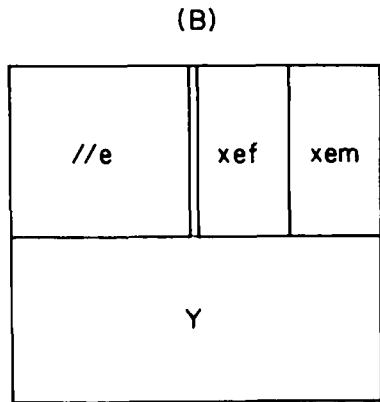

Figure 3. Notations illustrated for the Samoan sibling terminology. (a) Lists the denotata for each of the sibling terms. (b) Arranges these terms in “square” or box notation and (c) gives a “cubic” representation. Note that in (c) the labeling of the cube is determined by naming the dimensions and giving the values on each dimension for one point of the cube.

“square” notation (b), the following convention is used: horizontal lines represent a relative age cut, with “elder” above and “younger” below; single vertical lines represent a sex (of referent) cut, with “male” to the left and “female” to the right; a double vertical line represents a parity distinction, with “same sex” on the left and “opposite sex” on the right.

The lattice of unlabeled terminologies shown in Figure 4 is formed by successive binary partitioning. For the sake of generality, we can define *evolubility* of a partition using face operators.





First note that any conjunctive concept C within an n-dimensional space can be considered as a subcube of the n-cube and be defined by the coordinate vector  $(x_1, \dots, x_n)$  where  $x_i = 0, 1,$  or  $*$ .  $*$  is used to signify those dimensions on which the concept C makes no distinction (for example, English “brother” might be represented as  $(*,*,0)$  and “sister” as  $(*,*,1)$ , since neither distinguishes age or parity). For every positive integer  $i \leq n$  we define its *ith* upper face  $\partial_i^1(C)$  and its *ith* lower face  $\partial_i^0(C)$  by

$$\begin{aligned} \partial_i^1(C) &= (x_1, \dots, x_{i-1}, 1, x_{i+1}, \dots, x_n) && , \text{ if } x_i = * \\ & && (x_1, \dots, x_n) && , \text{ if } x_i \neq * \\ \partial_i^0(C) &= (x_1, \dots, x_{i-1}, 0, x_{i+1}, \dots, x_n) && , \text{ if } x_i = * \\ & && (x_1, \dots, x_n) && , \text{ if } x_i \neq * \end{aligned}$$

It should be noted that if  $x_i = *$  the face operators cut (i.e., partition) the subcube C into two faces  $\{\partial_i^1(C), \partial_i^0(C)\}$ , that differ only on the *ith* dimension.

With these operators, we can recursively define *evoluble* n-cube partitions. The 1-class partition is evoluble. Inductively, if the partition  $(B_1, \dots, B_k)$  is evoluble and if C is a face with coordinates  $(x_1, \dots, x_i, \dots, x_n)$  then the partition  $\{B_j | B_j \not\subset C\} \cup \{\partial_i^1(B_j) | B_j \subset C\} \cup \{\partial_i^0(B_j) | B_j \subset C\}$  is also evoluble.

In the case at hand, Figure 5 shows the fifteen labeled terminologies evolved after

two partitionings. If we allow complete binary partitioning of the three terminologies (2, 3, 4), then three additional terminologies (17, 18, 19) are evolved. These three may also be evolved from terminologies in turn evolved from the second partitioning. For example, terminology 17 may be evolved from 5, 6, 9, or 10; 18, from 7, 8, 13, or 14; and 19, from 11, 12, 15, or 16. Thus, in terms of evolution of labeled sibling terminologies, it is worthwhile noting that a step from a two-term system to a four-term system *need not* go through an intermediate partition with three terms; that is, a terminology of four terms can evolve from a two-term terminology in a single step if the new distinction “cross cuts” the old. Thus  may come from  or . In fact, some four-term systems can only evolve from a unique two-term partition. For example,  can only evolve from a binary partition of the system .



Figures 4 and 5 contain almost all the types of sibling terminology found empirically. Thus, all of Nerlove and Romney’s twelve basic types and Murdock’s (1968) seven types are included. Nerlove and Romney’s Type 12 is easily seen to derive, according to our hypothesis (see Fig. 5), from a partition of type 5 or type 8. Murdock’s (1970) revised types, a refinement of his 1968 types, are also easily derived. Finally, a hitherto unreported type, , the Samoan, can be seen to be, according to our hypothesis, derived from type 9 (  ) by a single partition on the *xe* sub-space. This means that, for practical purposes, all of the major *sibling terminologies* we deal with comprise only a subset of the lattice shown in Figure 4, namely, from the upper bound (  ) to those systems having four terms. This upper semi-lattice contains forty-nine of the 146 evoluble terminologies.

Figure 4 shows the lattice of unlabeled sibling terminologies. Each unlabeled structure can be labeled in forty-eight different ways. Specifically, the three dimensions can be interpreted as sex, relative age and parity in  $3! = 6$  ways, and each of the dimensions can have the values assigned in two ways. Some of these labelings are equivalent or iso-

NUMBER OF TERMS USED

NUMBER OF  
DISTINCT LABELINGS

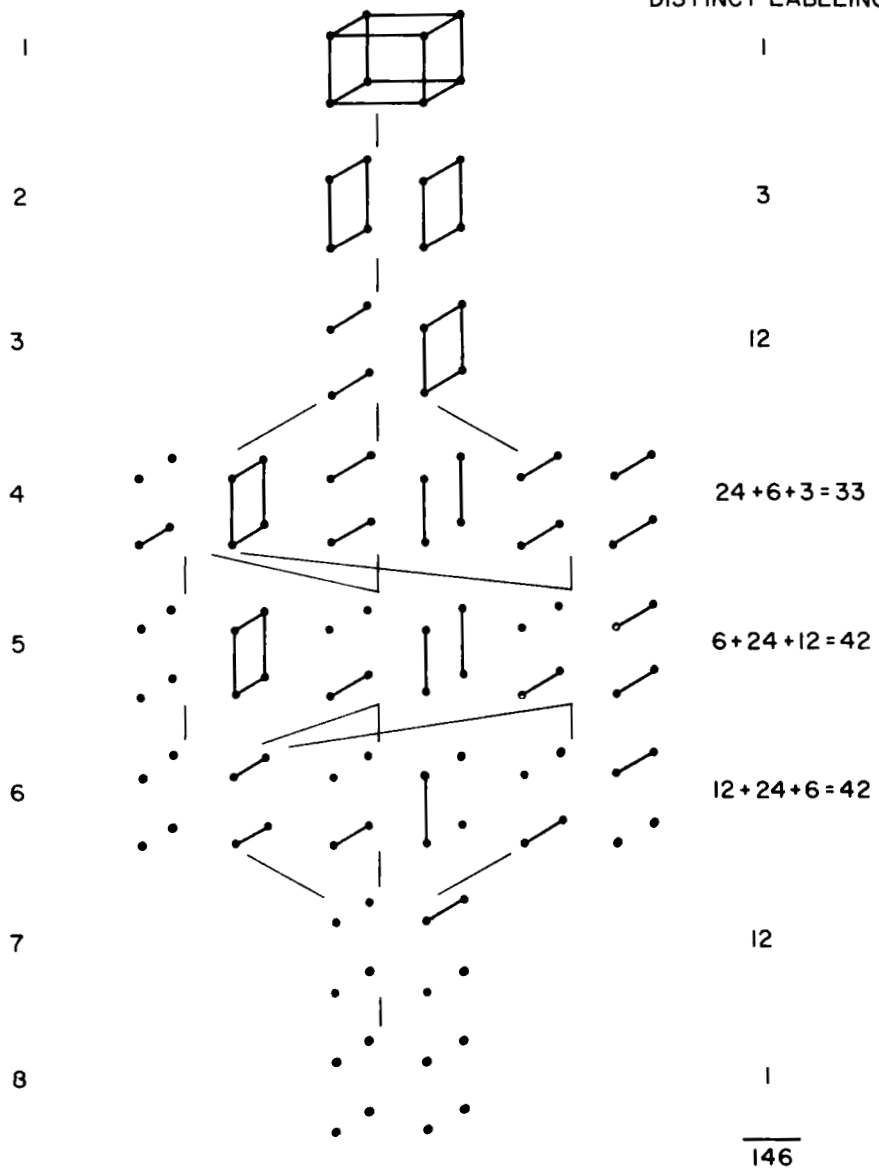

Figure 4. Lattice of unlabeled conjunctive sibling terminologies. The number of sibling terminologies that it is possible to obtain by different labeling is listed on the right.

morphic. A formal definition of isomorphic labelings need not be given here. The basic idea is that two labelings are isomorphic if

they class together the same sibling kin-types, that is, if they generate the same partition.

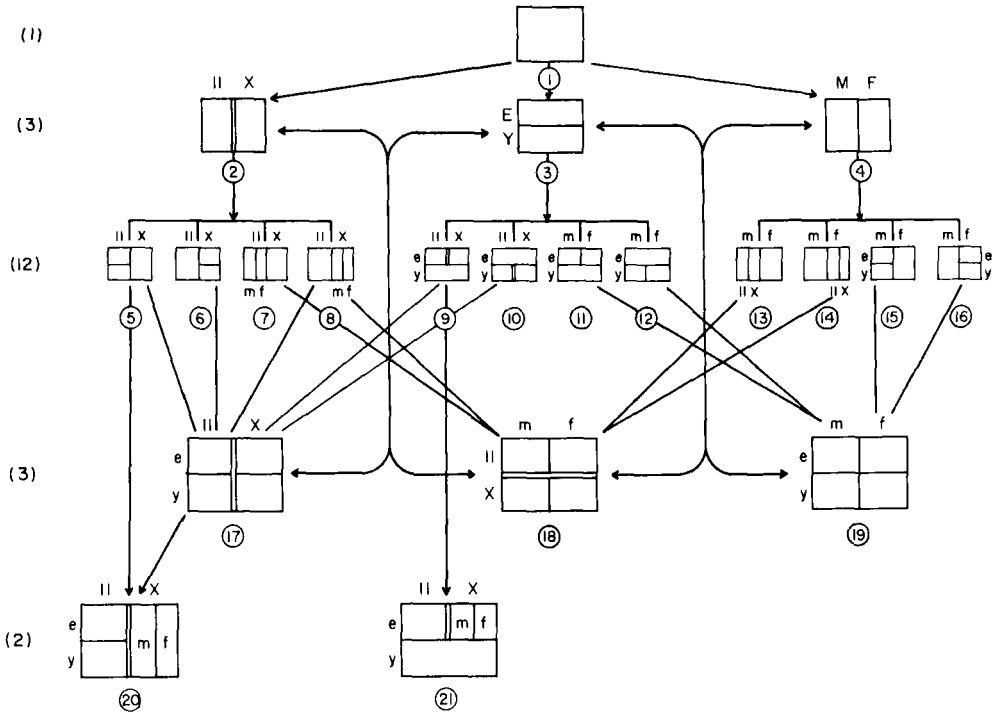

Figure 5. Upper semi-lattice of conjunctive sibling terminologies, showing paths or chains of evolution for the five types found in Polynesian languages.

Figure 6 gives one example of a labeling, in square notation, for each unlabeled type in the lattice of Figure 4.

We intend to restrict the psychologically admissible sibling terminologies even further than did Nerlove and Romney (1967). Of the 4140 possible partitions, they considered only the 194 partitions whose equivalence classes were conjunctive concepts. Of these 194, forty-eight are not evolvable. The forty-eight terminologies that are excluded on this basis correspond to only one unlabeled terminology as shown in Figure 7. This terminology could not have been obtained by means of a sequence of binary cuts since there is a line to "block" any of the three possible first cuts. The reason there are so many ways to label the system of Figure 7,

is that there are no symmetries of the unlabeled figure.

Notice again that Samoan sibling terminology can only be obtained by the sequence of binary cuts, as shown in Figure 8. Also note that any sequence of binary cuts generates a conjunctive terminology.

One justification for restricting sibling terminology to evolvable partitions is the hypothesis that the evolution of any sibling terminology is largely a process of making new binary distinctions and/or of removing old ones. This is *a priori* rather reasonable, but corresponds both to evidence and to parsimony. The evidence for this hypothesis of successive cuts may be termed existential. The fact that Nerlove and Romney (1967) found that, out of 245 of a world-wide



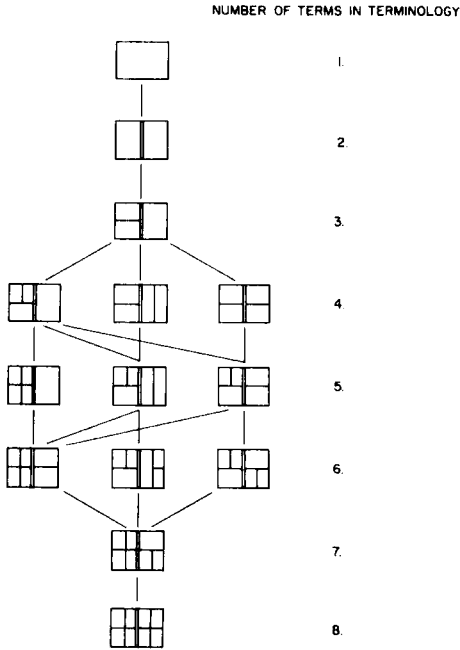

Figure 6. Examples of labeled sibling terminologies. One example is given for each of the unlabeled types of Figure 4.

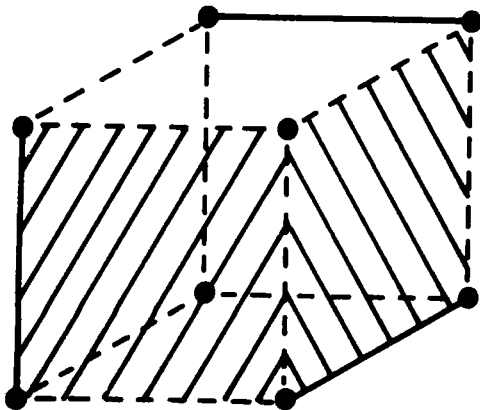

Figure 7. The one unlabeled sibling terminology that is unobtainable by means of a series of binary cuts.

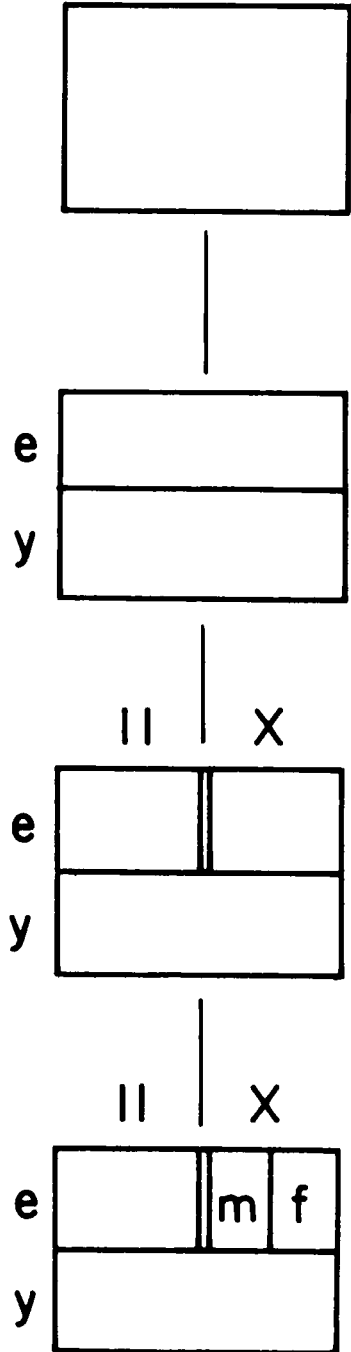

Figure 8. A sequence of binary cuts generating the Samoan sibling terminology. This also represents a possible evolutionary sequence.

sample of existing sibling terminologies, 240 fall into this set of 146 evolvable terminologies, together with the fact that in the complement set of 3994 terminologies, only four real examples are found, suggests that the hypothesis has non-trivial explanatory power. The other justification is of a *metric* character. The hypothesis of successive cuts permits as a distance measure (between any two types) the minimum number of cuts that have to be made or broken in order to obtain one terminology from another. This is sometimes known as the "natural lattice metric." The metric so obtained can then be compared with other independently obtained measures of the degree of association between societies and languages in question. A different metric with similar implication is one based on information theory.

#### INFORMATION MEASURES OF AND DISTANCE BETWEEN TERMINOLOGIES

Information-theoretic measures are additive functions of probability spaces, so the first step is to define the probability space. A sibling terminology is considered as a partition of the eight kinds of sibling relations. A probability measure,  $P$ , is therefore induced on a sibling terminology if we assume a uniform distribution on the eight points of the cube, for example,  $P(em) = P(xem) + P(/em) = 1/8 + 1/8 = 1/4$ . Now to get an information-theoretic distance measure between two different systems, we need a joint probability measure. This is done merely by assuming that the joint probability of two sibling terms from different terminologies is equal to the probability of the intersection of the two terms, for example,  $P(m, y) = P(m \cap y) = P(y) = 1/4$ .

Now that the probabilities are defined the information measures can be introduced. If the sibling terminology  $X$  has probabilities  $P_1, \dots, P_n$  then the uncertainty of  $X$ , written  $H(X)$ , is defined to be

$$H(X) = -\sum_{i=1}^n p_i \log_2 p_i.$$

The uncertainty is a measure of structural complexity which has many reasonable

properties such as being non-negative, and for a fixed number of points being at a maximum when the probability distribution is uniform. Notice that when  $X$  does have a uniform distribution  $H(X) = \log_2 n$ , where  $n$  is the number of points. Given the joint probability space  $(X, Y)$  with the probabilities  $P_{ij}$  for  $1 \leq i \leq m$  and  $1 \leq j \leq n$ , the joint uncertainty is really just the uncertainty of the joint space. A reasonable unnormalized measure of similarity is the information transmitted  $I(X, Y)$ , which is given by  $I(X, Y) = H(X) + H(Y) - H(X, Y)$ . This measure is non-negative and equals zero if and only if  $X$  and  $Y$  are statistically independent. The normalized distance measure which is used here is then:

$$D(X, Y) = \frac{H(X, Y) - I(X, Y)}{H(X, Y)},$$

and the corresponding similarity measure is  $S = I(X, Y)/H(X, Y)$ .

#### POLYNESIA: AN EMPIRICAL CASE

##### *Taxonomy*

To illustrate the applicability of the theory developed here, we now briefly examine the terminologies of a sample of Polynesian societies.

Table I lists the sibling terms and primary denotata of the twenty-three societies of our sample. Figure 9 shows the terminologies in square representation. The twenty-three terminologies fall into five types, four of which are congruent with types in Nerlove and Romney's (1967) typology and are also implied in Murdock's (1968) typology. A single case (Samoa) represents a heretofore undescribed type.<sup>2</sup>

Reasonable patterns of similarity (that is, taxonomies) of these terminologies are shown in Figures 10 and 11 which are hierarchical clusterings of the terminologies in the sample. Figure 10 is based on the similarity numbers  $I(X, Y)/H(X, Y)$  given in Table II (upper half). (The rationale of this similarity measure was presented above.)

TABLE I. SIBLING TERMS AND THEIR PRIMARY DENOTATA,  
 TWENTY-THREE INSULAR POLYNESIAN SOCIETIES\*  
 (items marked with an asterisk (\*) in the bibliography are sources used)

1. Kapinga	tuahina, sib.
2. O-Java	kainga, / /; ave, x
3. Pukapuka	taina (kainga), / /; tuatane, xm; tuawahine, xf
4. Tokelau	taina, / /; tuagane, xm; tuafafine, xf
5. Tikopia	taina, / /; kave, x
6. Samoa	uso, / /e; tuagane, xem; tuafafine, xef; tei, y
7. Tonga	taokete, / /e; tehina, / /y; tuagane, xm; tuofafine, xf
8. Hawaii	(kai) kua'ana, / /e; (kai) kaine, / /y; (kai) kuanane, xm; (kai) kauhine, xf
9. Marquesas	tua'ana, / /e; teina, / /y; tuanane, xm; tuehine, xf
10. Mangaia	tuakana, / /e; teina, / /y; tuagane, xm; tua'ine, xf
11. Easter	tuakana, / /e; taina, / /y; tama'aror, xm; tuahine, xf
12. Futuna	taina, / /; tua'n (tuaga'ane), x
13. Rennell	ta'okete, / /e; taina, / /y; tuagane, xm; tuahahine, xf
14. Mangareva	tuakana, / /e; teina, / /y; tuagane, xm; tue'ina, xf
15. Raroia	tuakana, / /e; teina, / /y; tuagane, xm; tuahine, xf
16. Ellice	taina, / /; tuagane, x
17. E. Uvea	ta'okete, / /e; tehina, / /y; tuagane, xm; tuafafine, xf
18. Tahiti	tua'ana, / /e; teina, / /y; tua'ane, xm; tuehine, xf
19. Nukuoro	teina, sib
20. Niue	ta'okete, / /e; tehina, / /y; tugane, xm; mahakitaga, xf
21. Manahiki	tuakana, / /e; teina, / /y; tuagane, xm; tuahine, xf
22. Tongareva	tuakana, / /e; taina, / /y; tuagane, xm; tuahine, xf
23. New Zealand	tuakana, / /e; teina, / /y; tuagane, xm; tuahine, xf

\*Orthography after original sources: both "g" and "ng" invariably represent /ŋ/.

This analysis provides a taxonomy of societies and sibling terminologies. We argue that such a description of similarity patterns among related forms is more than the end-point of an idle formal operation. It serves also as the beginning for central questions of social and historical process—phylogenetic questions.

This pattern of sibling terminologies did not, we presume, occur at random, or in a social vacuum. In the remainder of this article we will make a beginning toward specifying the set of processes which must have generated it.

### Origins

A variety of genetic and functional models of the development of these patterns are available. The formal characterization presented here for inter-societal patterns makes possible straightforward empirical tests of the applicability of these models. In the Polynesian case, it seems that economic features account for a far higher proportion of differential development of sibling terminologies than do others.

On a basis of a rather exhaustive study of sibling terminology among a sample of about

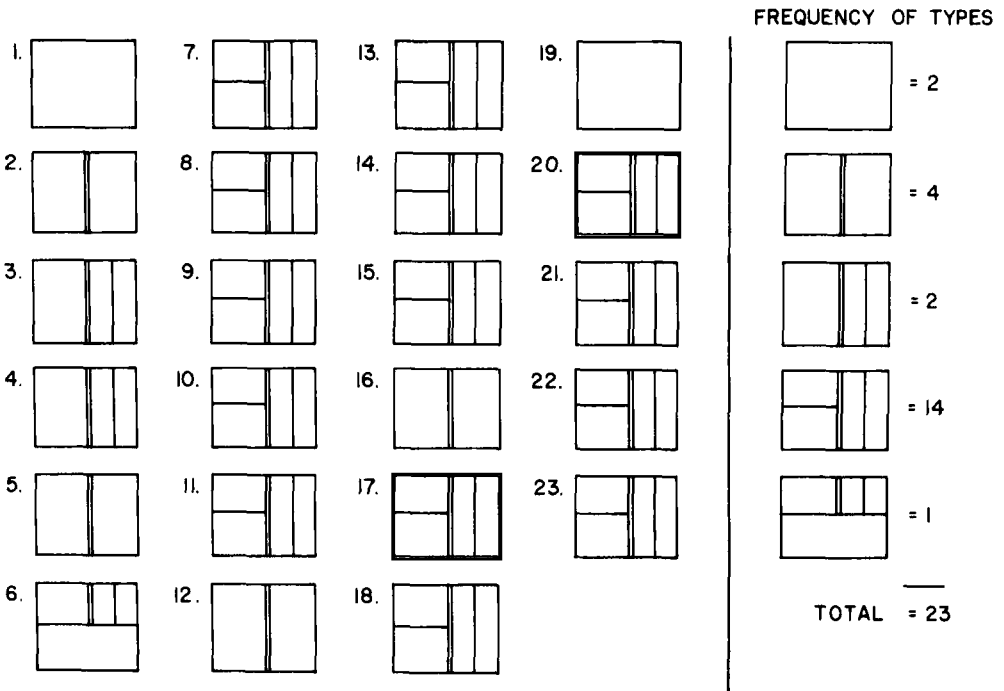

Figure 9. Box diagrams, sibling terminologies of twenty-three Polynesian societies. See Table I for names of cases one through twenty-three.

800 societies, Murdock (1968:11) suggests a threefold explanation of patterns of sibling terminology:

It has now been shown that (1) the process which governs the development of patterns of sibling terminology is most typically the genetic one which also governs the evolution of language itself, so that the patterns tend strongly toward correlation with linguistic groupings, but that (2) under particular sets of circumstances a second process intervenes, namely, that of cultural or linguistic borrowing or diffusion. There remains to be considered a third process, one involving function determinants. This is an integrative process in which certain aspects of culture or social organization exert pressure on other aspects (through individual behavior, of course), thus tending to bring the latter into adaptive conformity with the former.

We examine each of these three processes (hypotheses about the origin of the observed

taxonomy), as they apply to the Polynesian case, turning first to Murdock's genetic hypothesis (number 1 above).

Murdock's hypothesis is that "patterns [of sibling terminology] tend strongly toward correlation with linguistic groupings . . ." A reasonable test of the hypothesis is provided by lexicostatistical data on languages of the societies in our sample, recently made available by Kirk and Epling (1972, 1973). Table II gives the most comprehensive data available on the similarity of Polynesian languages, as measured by the proportion of a standard subvocabulary which are cognates. Figures 12 and 13 are summary representations of the pattern of similarity among these Polynesian languages. Nineteen of the twenty-three cases in a sibling sample are included in the data. The correlation of the similarity values between sibling terminologies of these nineteen societies and the dis-

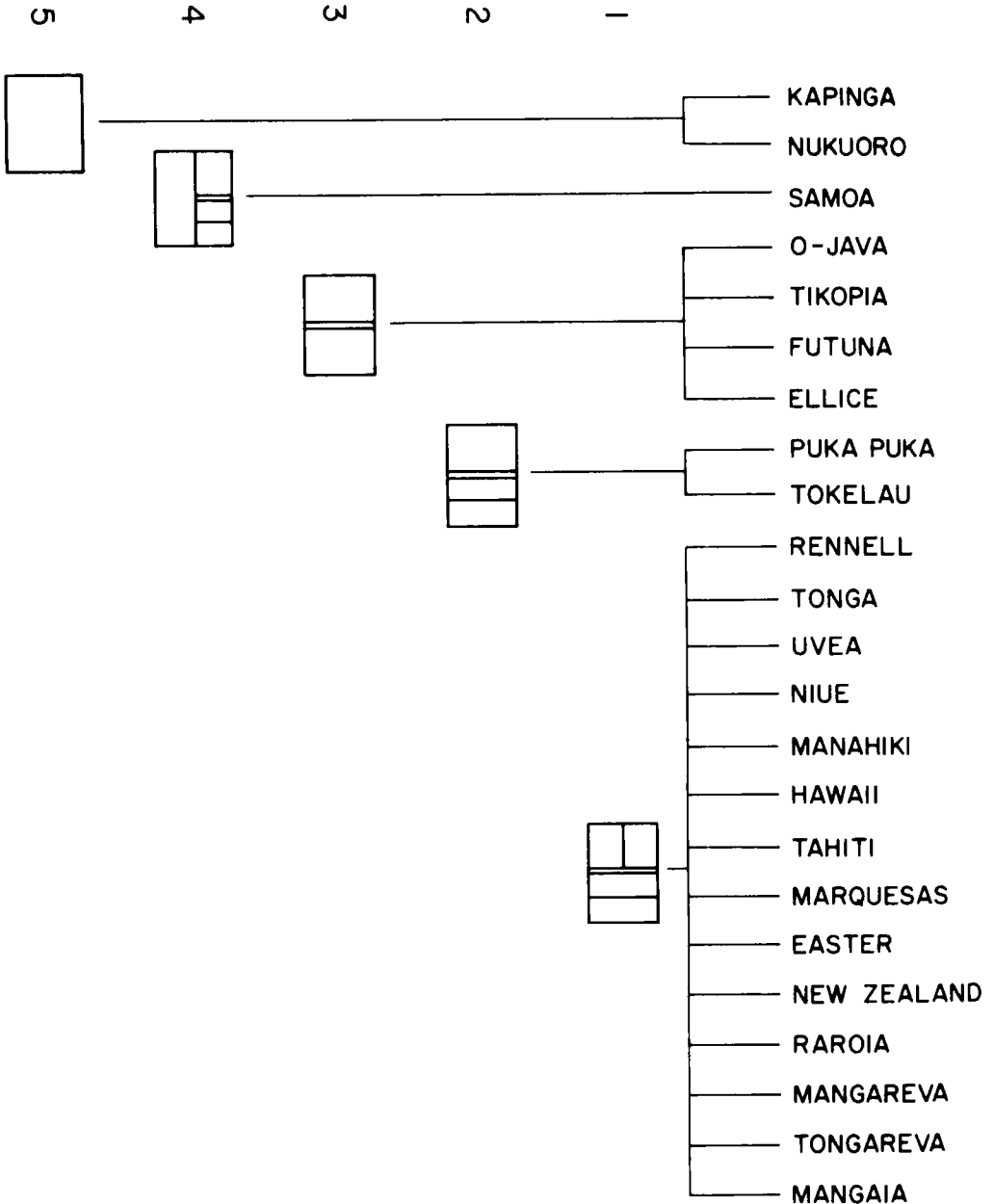

Figure 10. Hierarchical clustering of twenty-three Polynesian Sibling Terminologies by Johnson (1967) diameter method [ $S=I(X,Y)/H(X,Y)$ ].

similarity values for these nineteen languages (Table II, upper half) derived from multi-

dimensional analysis of the lexical similarity numbers is  $r = .118$ . While this correlation is

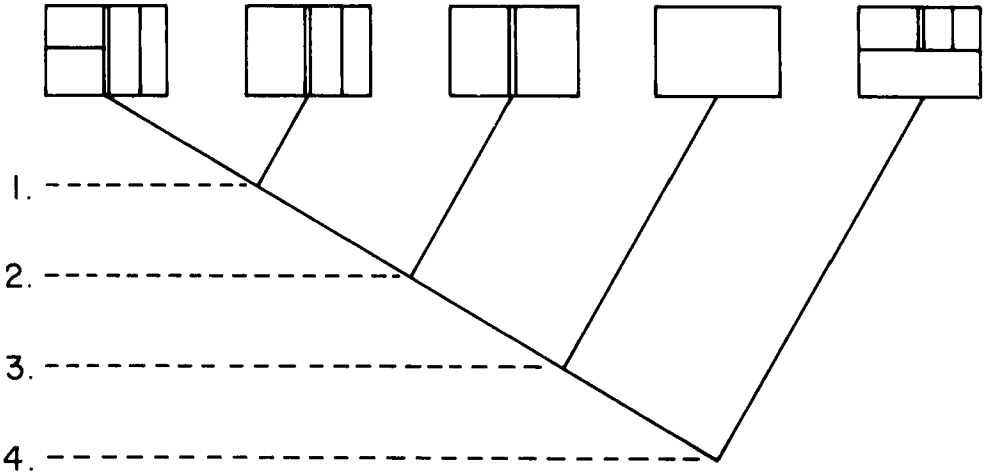

Figure 11. An equally "valid" similarity scheme, hierarchical clustering of types using the natural lattice distance of the respective types of sibling terminology (see Fig. 15).

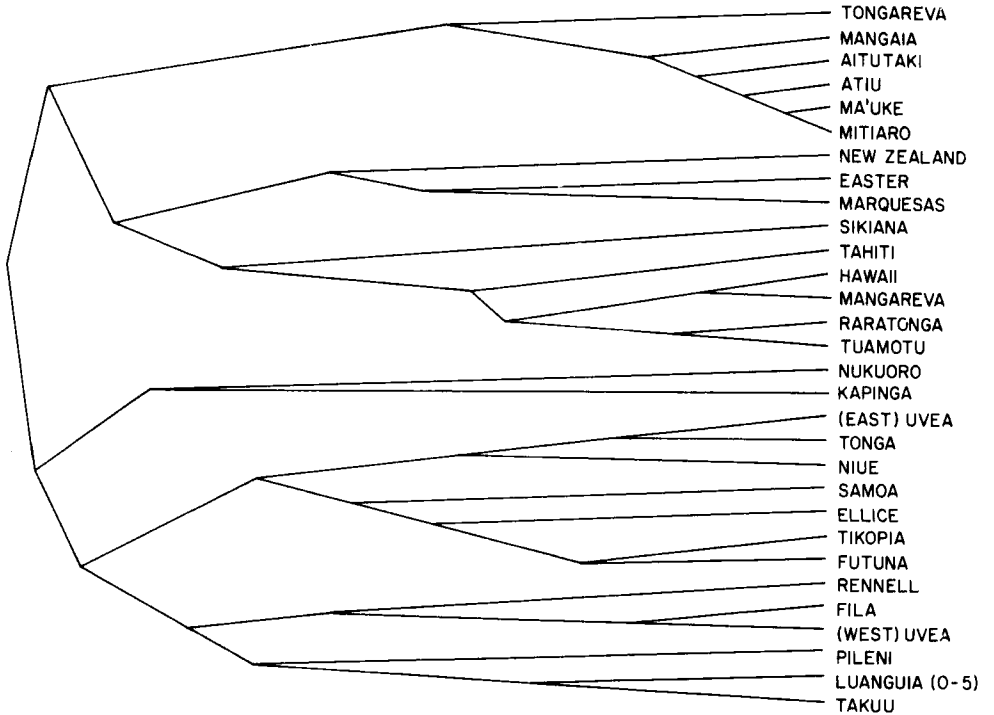

Figure 12. Hierarchical clustering of aggregate lexical similarity indices, thirty Polynesian languages. (Type of sibling terminology for each language/society in the sample shown in Figure 9.)

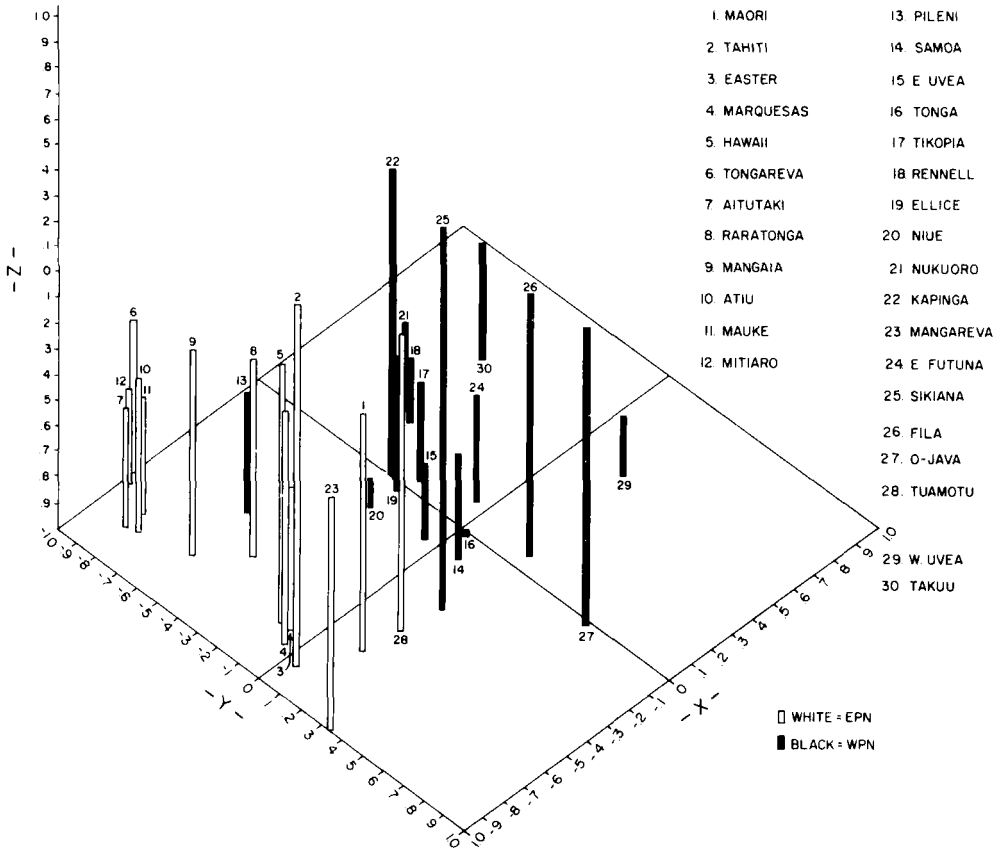







Figure 13. A three-dimensional representation, percent cognates N = 30 Polynesian languages. Guttman-Lingoes analysis, Kruskal's stress = .12.

significant at the ten percent level, it can be interpreted as at best only a very weak association between the variables.

Reference to Figures 10 and 11 shows that the sibling terminologies of our sample fall into two main groups: types {  ,  ,  } and {  }. It will be seen that four of the fourteen terminologies of type  are clearly West Polynesian linguistically, while the remaining ten are clearly East Polynesian. The relative weakness of the correlation of language with sibling terminology structure may be attributed in large part to the presence of these four

deviant cases. The Polynesian case thus offers only weak confirmation of Murdock's genetic hypothesis. Certainly, it is considerably less convincing than Murdock appears to believe.

A further test of Murdock's genetic hypothesis is provided by our hypothesis of evolutionary development, namely, that of a process of successive binary partitions (Fig. 14) evolutionary distances between the five types may be counted, as in Figure 15, using the natural lattice metric as

TABLE II. UPPER HALF OF MATRIX, SIMILARITY NUMBERS, TWENTY-THREE POLYNESIAN SIBLING TERMINOLOGIES, (X,Y)/H(X,Y), LOWER HALF OF MATRIX, BEST (INTER-LANGUAGE) DISTANCES, FROM THREE DIMENSIONAL ANALYSIS (KRUSKAL) OF PERCENT COGNATE VALUES, THIRTY POLYNESIAN LANGUAGES (from Kirk and Eping 1973)

	1	2	3	4	5	6	7	8	9	10	11	12
1.	1.000	0.000	0.000	0.000	0.000	0.000	0.000	0.000	0.000	0.000	0.000	0.000
2.	.976	1.	.667	.667	1.000	.222	.500	.500	.500	.500	.500	1.000
3.			1.	1.000	.667	.300	.750	.750	.750	.750	.750	.667
4.				1.	.667	.300	.750	.750	.750	.750	.750	.667
5.	1.351	.793			1.	.222	.500	.500	.500	.500	.500	1.000
6.	1.453	1.326			.738	1.	.500	.500	.500	.500	.500	.222
7.	1.925	1.310			1.161	1.264	1.	1.000	1.000	1.000	1.000	.500
8.	2.156	1.813			1.021	.861	1.657	1.	1.000	1.000	1.000	.500
9.	2.367	1.730			1.368	1.395	.541	1.527	1.	1.000	1.000	.500
10.	2.160	1.313			1.311	1.698	.639	1.917	.839	1.	1.000	.500
11.	2.471	1.818			1.283	1.329	.894	1.200	.461	1.071	1.	.500
12.	1.563	1.097			.315	.567	1.172	.723	1.268	1.399	1.114	1.
13.	1.733	1.397			1.091	1.565	2.224	1.447	2.369	2.206	2.160	1.197
14.	1.926	1.396			.913	.855	.563	1.119	.543	1.009	.593	.780
15.												
16.	1.261	.714			.227	.869	.949	1.164	1.233	1.179	1.239	.450
17.	1.851	1.499			.728	.784	1.620	.406	1.616	1.830	1.343	.499
18.	2.132	1.688			1.542	1.461	.457	1.920	.683	.998	1.114	1.516
19.	1.005	1.402			1.290	1.350	2.306	1.731	2.584	2.526	2.505	1.399
20.	2.208	1.598			.908	1.265	1.648	.735	1.150	1.648	1.205	.771
21.												
22.	2.453	1.483			1.535	2.128	1.356	2.149	1.447	.754	1.484	1.670
23.	2.136	1.661			1.212	1.029	.614	1.284	.499	1.132	.601	1.061



TABLE II (continued)

	13	14	15	16	17	18	19	20	21	22	23
1.	0.000	0.000	0.000	0.000	0.000	0.000	0.000	0.000	0.000	0.000	0.000
2.	.500	.500	.500	1.000	.500	.500	0.000	.500	.500	.500	.500
3.	.750	.750	.750	.667	.750	.750	0.000	.750	.750	.750	.750
4.	.750	.750	.750	.667	.750	.750	0.000	.750	.750	.750	.750
5.	.500	.500	.500	1.000	.500	.500	0.000	.500	.500	.500	.500
6.	.500	.500	.500	2.222	.500	.500	0.000	.500	.500	.500	.500
7.	1.000	1.000	1.000	.500	1.000	1.000	0.000	1.000	1.000	1.000	1.000
8.	1.000	1.000	1.000	.500	1.000	1.000	0.000	1.000	1.000	1.000	1.000
9.	1.000	1.000	1.000	.500	1.000	1.000	0.000	1.000	1.000	1.000	1.000
10.	1.000	1.000	1.000	1.000	.500	1.000	1.000	0.000	1.000	1.000	1.000
11.	1.000	1.000	1.000	.500	1.000	1.000	0.000	1.000	1.000	1.000	1.000
12.	.500	.500	.500	1.000	.500	.500	0.000	.500	.500	.500	.500
13.	1.	1.000	1.000	.500	1.000	1.000	0.000	1.000	1.000	1.000	1.000
14.	1.950	1.	1.000	.500	1.000	1.000	0.000	1.000	1.000	1.000	1.000
15.			1.	.500	1.000	1.000	0.000	1.000	1.000	1.000	1.000
16.	1.346	.776		1.	.500	.500	0.000	.500	.500	.500	.500
17.	1.063	1.559		.932	1.	1.000	0.000	1.000	1.000	1.000	1.000
18.	2.627	.815		1.307	1.949	1.000	1.000	1.000	1.000	1.000	1.000
19.	1.114	2.064		1.389	1.394	1.828	0.000	0.000	0.000	0.000	0.000
20.	1.112	1.252		1.131	.608	2.032	1.307	1.	1.000	1.000	1.000
21.									1.	1.000	1.000
22.	2.084	1.565		1.525	1.999	1.749	2.685		1.628	1.	1.000
23.	2.245	.306		1.061	1.395	1.685	2.308		1.497	1.750	1.

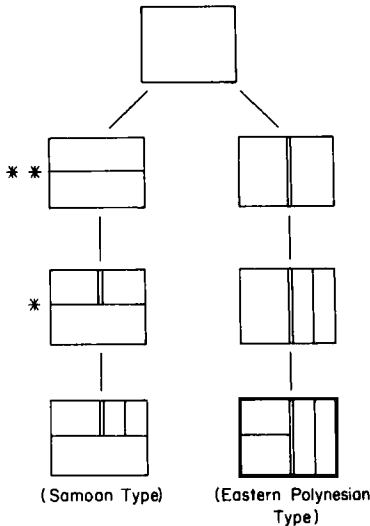

\* Not observed  
 \* \* Reconstructable for Marquesas, early 19<sup>th</sup> century

Figure 14. Upper semi-lattice of sibling terminologies showing the two reconstructed evolutionary lines (chains).

a measure of distance.

If the evolution of sibling terminologies followed the evolution of lexicon in general, we would anticipate a significant correlation between the lattice distances (Fig. 15) and the lexicostatistical distances or similarities (e.g., percent cognate values or best distances as in Table II lower). This is not the case. The correlation between the evolutionary lattice distances and the estimate of lexicostatistical distances is only  $r = .166$ . (The evolutionary distances, it will be recalled, are counted as the number of binary partitions that separate one terminology from the other in the upper semi-lattices.)

We may conclude that evidence available indicates that if the Polynesian sibling terminologies developed according to our hypothesis, there is little connection between their distances (or similarities) based upon this process and the similarity of the languages as wholes which is presumably a function of broad "genetic process."

There is, then, evidence that language

similarity is not appreciably correlated with sibling-terminology similarity. While a language as a whole is probably relatively unsusceptible to specific "pressures," specialized lexical sets within it surely are—sets such as kinship terms in particular. The similarity numbers used as an index of linguistic similarity (percent cognate values) are based on two types of correspondence: form and meaning. Those used to index similarity of sibling terminologies ignore the particular terms used, and index only the structure (meaning). In a sense, the sibling similarity numbers are an index of cognitive similarity. In other words, these data illustrate once more there is independence between symbol, sign, and concept in languages.

As can be seen by reference to Figure 5, contemporary Polynesian terminologies conform almost exactly to our developmental or evolutionary hypothesis. The one exception (in the sample) is Samoa. Thus twenty-two of the twenty-three terminologies can be viewed as forming an evolutionary chain in the lattice of sibling terminologies which is a logical and reasonable one given our assumptions about evolution. It should be remembered that we allow for devolution, i.e., loss of a prior partition, and thus that the sequence of evolutionary events need not begin with the most simple type (  $\square$  ). It may "begin" anywhere along the chain. Thus, Firth's (1970) suggestion that the terminologies of several Polynesian outlier societies (Tikopia, Nukuoro, Kapingamarangi, etc.) are cases of "denuding" appears reasonable, in light of two lines of evidence: (a) the probably relative recency of divergence of at least some of these languages, as suggested by the lexicostatistical data, and (b) the fact that Nukuoro and Kapinga terms are clearly *compound analyzable forms*, suggesting that they are "recent" words.

It will be recalled that twenty-two of the terminologies shown in Table I form an upper semi-lattice (Fig. 14), which is formed according to our rule of successive binary partition. Thus, while displaying an apparent wide range of type, Polynesian terminolo-

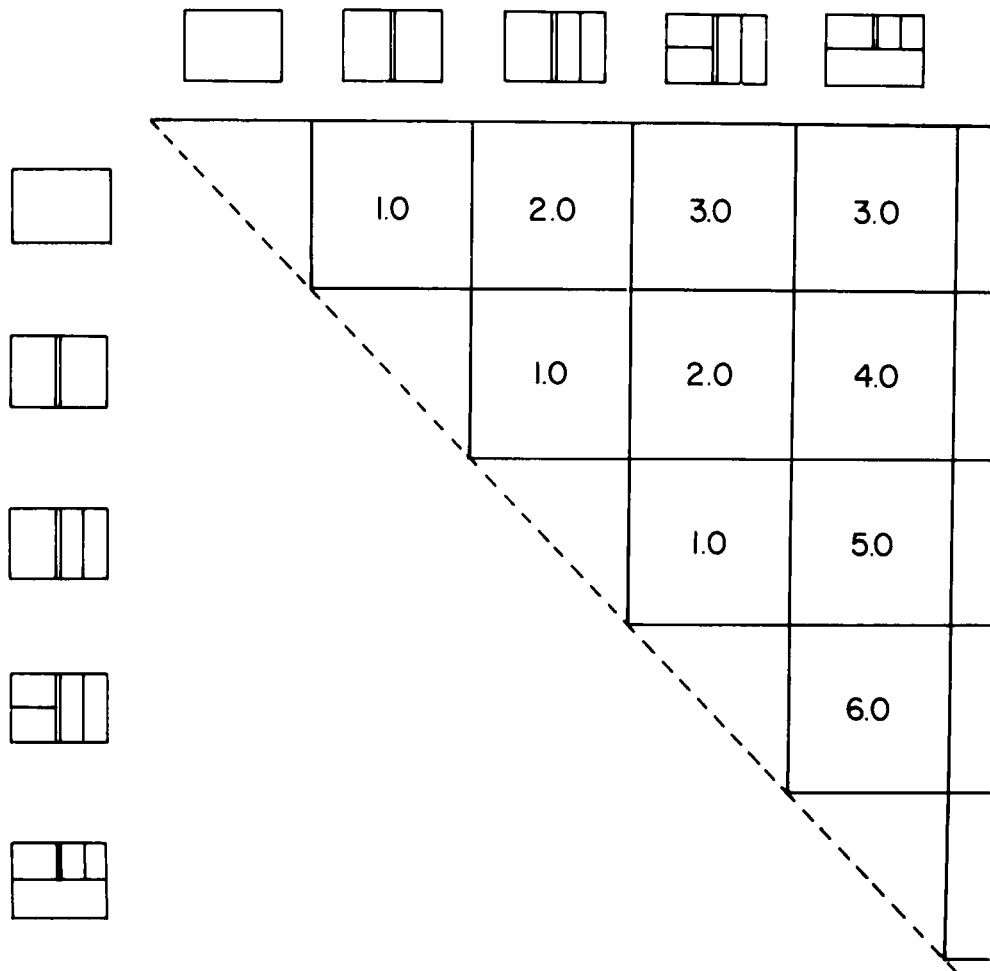

Figure 15. Distances between types of sibling terminology using the natural lattice metric (see Fig. 14). The correlation of these distances with estimates of lexical similarity (Kruskal best distances) is +.166 for our sample.





gies, actually (with the exception of the Samoan type) form a close-knit cluster. Each type of the cluster may be viewed as a specific instance of a general pattern and trend—namely, successive refinement on a basic theme of differentiation of parallel from cross siblings or, in the case of the “outliers,” loss of such refinements.

If we add the Samoan case, then it will be seen that the Polynesian semi-lattice assumes added types and complexity; the most prominent feature being two intermediate

types not reported for contemporary Polynesia and two distinct lines or chains of evolution. These are illustrated in Figure 14.

*The Special Case of Marquesas and Tuamotu*

According to our theory of successive binary splits as the most likely evolutionary process, the route or path of evolution for Samoan sibling terminology should proceed

through two steps between the beginner (  ) and the outcome (  ), namely (  ) and (  ) (Fig. 14).

Neither of these two intermediary types occur in our sample. The questions arise: did they once exist? and are they reconstructable?

De Vergnes, as reported in Williamson (1924, II:201-202), reported the following terminology for the Marquesas:

	//	X
e	(1) tuana	(3) tuane
y	(2) teina	(4) teine

This, of course, contrasts with the contemporary Marquesan system, which is the usual Eastern Polynesian type, labeled the four forms: 1 = *tua'ana*, 2 = *teina*, 3 = *tuanane*, 4 = *tuehine*, 3 and 4 apparently being "accretions."

Hale (1968[1846]) and later Pawley (1966) suggest that the endings /-na/ and /-ne/ are old Polynesian markers of the relation "near to the speaker" and "distant from the speaker" respectively—which we believe may be translated as our dimension parity, i.e., "parallel sex" and "cross sex," respectively. This is the case in contemporary Samoan.



If we use this hypothesis, then it seems intuitively reasonable to reconstruct early nineteenth century Marquesan sibling terminology as:

*tua(na,ne)*  
*tei(na,ne)*

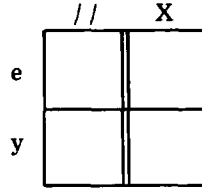
(assuming that analyzable forms are more recent than unanalyzables). This would, in the Marquesan case, yield a reconstruction of two terms /tua/ and /tei/ to which, at some later date, the endings /-na/ and /-ne/ were added, to produce the four term system reported:



Interestingly, our reconstruction for Marquesas yields an example of a type of sibling terminology predicted by our evolutionary theory, but not observed among contemporary Polynesian societies (Fig. 14). The evolution of Marquesas terminology to its present form (  ) is problematic, but suggestive of borrowing.

Also, this type of terminology (  ) is, as we have already shown, the necessary precursor type for the evolution of the Samoan type (  ). If the line of evolution implied by our theory continued in Eastern Polynesia, we should find a terminology of the Samoan type among Eastern Polynesian societies. Tuamotu society may in fact provide an example of this continued evolution.

That the evolution from this intermediate type may have continued in Eastern Polynesia is suggested by the fact that Tuamotu terminology, as reported in Williamson (1924, II:204-205) is:

	//	m	x	f
E	tuakana	tuagane	tuahine	
y	teina			

This is, of course, isomorphic with Samoan. The Tuamotu language is, according to recent analysis of lexicostatistical data, remarkably close to Western Polynesian languages (Kirk and Epling 1972, 1973), but clearly an Eastern Polynesian language (Figs. 12 and 13). This suggests an early (prehistoric) affinity heretofore unsuspected in the case of Tuamotu, but predicted for the Marquesas (Sharp 1964).

There is no evidence at the present for the existence of the second intermediate type. However, it stands as a prediction that should be reconstructable.<sup>3</sup>

*Functional Correlates*

We turn next to Murdock's third hypothesis (1968:11) which we call his functional hypothesis, the critical part being that: "certain aspects of culture or social organization exert pressure on other aspects . . . [i.e., sibling terminologies]."

A test of this functional hypothesis requires that we have a specific functional theory, that is, a theory that relates type of sibling terminology with one or more independent variables. We do not really have such a theory, but, can make several guesses, three of which are roughly testable with available data.

As we have seen, Murdock (1968) proposes that functional correlates play a significant role in the taxonomy and phylogeny of sibling terminologies, presumably *within* the genetic unit and the processes occurring in it. He shows (1968, Table 2) the correlation of his types F1 and F2 sibling terminologies (  $\square\square$  and  $\square\square\square$  ) with which he covers all but the Samoan case in our sample, with ambilineal descent. This association appears as a feature of the genetic unit and is reflected in the near universal distribution of the parallel/cross distinction in Polynesia (Table III).

Aside from this unit-wide association of the parallel/cross distinction and ambilineal descent no other correlations are intuitively obvious. The ethnographic data necessary for testing of hypotheses are not adequate either in quantity or quality. At best they are sufficient for suggesting hypotheses or gross patterns.

Nerlove and Romney (1967) suggest two interrelated functional hypotheses which can be tested in a cursory way for the Polynesian unit. First, that there is a positive functional relation between primacy of the parallel/cross distinction, and intensity or emphasis upon brother-sister avoidance practices. Table IV shows the distribution of Polynesian cases for the intersection of primacy of parallel/cross distinction (and type of sibling terminology) and emphasis or br-si avoidance practices. Disregarding the

obvious sampling deficiencies, it will be seen that the prediction does not hold up very well for our sample using the data available in the Ethnographic Atlas (Murdock 1967) for "segregation of adolescent boys" as an index to brother-sister avoidance practices (see Table III).

Second, Nerlove and Romney suggest another positive functional association between primacy of the parallel/cross distinction and length (intensity) of post-partum sex taboo. Table V shows the distribution of Polynesian cases on these two variables.

Sahlins' (1958) work, among others, suggests a positive correlation between "degree of social complexity" or "societal differentiation," and type and elaborateness of systems of social ranking which in turn appears related to levels of extractive efficiency and productivity. If we assume that sibling terminologies have social jobs to do (e.g., that they convey social information) it seems reasonable to posit a functional hypothesis such as: "the amount of information, H, of sibling terminology, is positively correlated with the degree of social differentiation and degree (emphasis on) of social ranking."

A preliminary test of this hypothesis is provided by comparing Sahlins' data with the information of sibling terminologies (Table VI). As a check, further data on the degree of social differentiation provided by Marsh (1967) are compared with the same information measure. In contrast to the relatively weak explanatory power of the other hypotheses we have suggested for sibling terminologies, Table VII shows a close fit. Dichotomizing the variables, the only exception to the prediction of the hypotheses is Marquesas. The correlation between Marsh's index of social differentiation and information of sibling terminology is  $r = .636$  for seventeen of our twenty-three cases.

Table VII provides additional indirect support for the hypothesis, showing how the sibling-terminology corresponds (with only three exceptions) to aboriginal population densities.

TABLE III. SUMMARY OF FUNCTIONAL CORRELATES DATA  
TWENTY-THREE POLYNESIAN SOCIETIES\*

	Column 24 (Murdock) Cognatic Kin Groups	Column 36 (Murdock) Post- Partum Sex Taboo	Column 38 (Murdock) Segregation of Adolescent Boys	Column 67 (Murdock) Class Stratification	Degree of Differentiation Score Marsh (1967)
1. Kapinga	K	3	T	D	1
2. O-Java	S	⊕	A	W	2
3. Pukapuka	K	1	A*	O	1
4. Tokelau	R	5	T	O	2
5. Tikopia	K	⊕	A	D	3
6. Samoa	S	4	A	D	4
7. Hawaii	Rk	⊕	∅	De	5
8. Tonga	R*	2	A	D	5
9. Marquesas	K	1	A	D	⊕
10. Mangaia	S	⊕	A	D	2
11. Easter	R	⊕	∅	D	3
12. Futuna	R	⊕	T	D	⊕
13. Rennell	⊕	⊕	∅	∅	3
14. Mangareva	R	2	∅	D	⊕
15. Raroia	Rk	⊕	∅	O	1
16. Ellice	S	2	T	D	2
17. Uvea	S	⊕	T	D	⊕
18. Tahiti	R	⊕	∅	D	4
19. Nukuoro	⊕	⊕	∅	∅	⊕
20. Manahiki	B*	⊕	∅	D	3
21. Tongareva	⊕	⊕	∅	∅	⊕
22. New Zealand	Rk	⊕	∅	D	4
23. Niue	R	⊕	∅	D	⊕

⊕ Range: 1 = min. to &gt; 150 maximum

∅ = no data or not treated in sample by investigator

*Key to Symbols*

Column 24: K = bilateral descent with reported kindreds  
 S = exogamous ramage  
 R = ramage  
 B = bilateral descent

Column 36: 1 = short, 1 month or less  
 2 = 2-6 months  
 3 = 7-12 months  
 4 = 13-24 months  
 5 = 25 months and over

Column 38: A = absent  
 T = complete segregation

Column 67: D = dual  
 E = elite stratification  
 W = wealth distinctions.  
 but no soc. classes

\*after Ethnographic Atlas (Murdock 1967)

TABLE IV. PARALLEL/CROSS DISTINCTION TABULATED AGAINST EMPHASIS ON BROTHER-SISTER AVOIDANCE FOR TWELVE OF TWENTY-THREE SOCIETIES IN THE SAMPLE

		not primary	primary	
Emphasis on Brother-Sister Avoidance	high emphasis	Kapingamarangi	Tokelau Futuna Ellice E. Uvea	5
	low emphasis	Samoa	O-Java Pukapuka Mangaia Tikopia Tonga Marquesas	7
		2	10	12

*Borrowing-Diffusion Hypothesis*

We turn finally to Murdock's second hypothesis (1968:11), that of borrowing and diffusion as a process that may influence patterns of sibling terminology: "under particular sets of circumstances a second process intervenes, namely, that of cultural or linguistic borrowing or diffusion."

As was pointed out above in discussing taxonomy, four of the fourteen societies in our sample having the terminological system

(  ) (Tonga, Rennell, E. Uvea and Niue) are in most regards clearly members of the large sub-class of languages/cultures termed "Western Polynesian," most closely allied with Samoa, Tikopia, etc. (see Figs. 10 and 11). The empirical reality of these two subgroups within Polynesia seems to be unquestionable.

As we have also seen, Eastern Polynesian sibling terminology appears to be the outcome of a rather uniform line (chain) of evolution, which is, within the genetic unit,

TABLE V. PARALLEL/CROSS DISTINCTION TABULATED AGAINST LENGTH OF POST-PARTUM SEX TABOO FOR EIGHT OF TWENTY-THREE SOCIETIES IN THE SAMPLE

	not primary	primary	
Length of Post-Partum Sex Taboo	<p>long (7 months and over)</p>	<p>Kapingamarangi Samoa</p>	<p>Tokelau</p> <p style="text-align: right;">3</p>
	<p>short (6 months and less)</p>		<p>Pukapuka Tonga Futuna Ellice Marquesas</p> <p style="text-align: right;">5</p>
	2	6	8

quite distinct from the line of evolution posited for the Samoan type (Fig. 8), this line possibly representing a sequence of events common to "core," "archaic," or "nuclear" Polynesian languages and societies. A confusing item here is the fact that all the Western Polynesian societies in the sample except Samoan and the two outliers (Nukuoro and Kapingamarangi) would seem to belong to the Eastern line of evolution rather than to a Western line or chain.

Within our sample of twenty-three societies, the four cases in question share a "unique label" for one of the four categories

in this system: *ta'okete* (or some obvious variant), denoting the /e category. This word has widespread distribution in Eastern Polynesian languages, as a kin term, usually having as its referent affinal kin types.

Evidence such as this, plus trait studies such as those of Burrows (1938), inclines us to suggest that the contemporary sibling terminology, cognitively and linguistically, of these four societies is a likely case of diffusion-borrowing. The source of the innovations seems to be Eastern Polynesia, and the impetus for it may well be a rather large scale East to West counter migration, possi-



TABLE VI. TYPE OF SIBLING TERMINOLOGY AND AMOUNT OF INFORMATION OF TERMINOLOGY AGAINST INDICES OF SOCIAL STRATIFICATION/DIFFERENTIATION (scale values: Sahlins, 1 = high, 4 = low; Marsh, 1 = low, 5 = high)

Society	Type sibling terminology	Amount of information (entropy of system) = $H = -\sum p_i \log_2 p_i$	Sahlins' index of social stratification	Marsh's index of social differentiation	
Hawaii		2.0	1	5	
Tonga		2.0	1	5	
Tahiti		2.0	1	4	
Samoa		1.75	1	4	"High degree of stratification"
Mangareva		2.0	2	φ	
Easter		2.0	2	3	
(East) Uvea		2.0	2	φ	
Mangaia		2.0	2	4	
Marquesas		2.0	3	2	
Tokelau		1.5	4	1	
Pukapuka		1.5	4	2	"Low degree of stratification"
O-Java		1.0	4	2	
(East) Futuna		1.0	3	φ	
Tikopia		1.0	3	1	

after Sahlins (1958)

bly beginning around the ninth to eleventh centuries A.D. and being intimately connected with the "final" settlements of Eastern Polynesian peoples in outlier Eastern Polynesia which yielded the distribution as it was observed at the dawn of European discovery (see Kirk and Epling 1972).

#### HISTORICAL SPECULATIONS

We here indulge in a few historical speculations, guided in a general way by the foregoing formal analysis.

First of all, on the basis of available evidence, it seems clear that the contemporary pattern of sibling terminology within the Polynesian genetic unit, as estimated from our sample, cannot be "explained" independent of the time dimension. That is, the specific solutions observed at  $T_1$  ( vs. ) while being structurally and functionally very similar, seem to be the end-products of rather distinct parallel evolutions. This easily appreciated by reference to our discussion of chains above.

A general trend, throughout the genetic

TABLE VII. ENTROPY (H(X)) OF SIBLING TERMINOLOGY AGAINST ESTIMATED POPULATION DENSITIES, A.D. 1900

	0.0 - 1.50	1.75 - 2.00		
Estimated Density of Population, A.D. 1900	300-over per sq. mile	Kapinga O-Java Tokelau Tikopia Pukapuka Ellice Nukuoro Manahiki	(East) Uvea Tongareva	10
	1-299 per sq. mile	(East) Futuna	Niue Samoa Tonga Hawaii Mangaia Marquesas Easter Rennell Mangareva Tahiti New Zealand	12
	9 (Raroia deleted)	13	22	

unit, from  $T_0$ , of increasing differentiation of sibling distinctions (i.e., increasing  $H$  of the sibling term ensemble) is quite obvious. Moreover, this appears to be a unit-wide tendency, cutting across the linguistic-phylogenetic "line" (Eastern/Western). The particular outcomes of this general process were probably determined by the nature of the precursor, types (  $\square$  vs.  $\square\square$  ), thus producing two lines of evolution.

Our analysis of sibling terminologies has up to this point been non-linguistic, in the sense that aside from detecting sibling categories on the basis of contrastive labeling we

have not dealt with the language forms (words) of the events. Thus, we have in fact been analyzing categories independent of their language codings. Though the details of the history of language codings are the professional domain of historical linguists (a domain whose analysis requires skills that we do not command), a few features of this history, which is intimately related to our focus, may not be out of place.

Reference to Table I will show that there are, within our sample, four words which might be "reconstructed" for an arbitrary  $T_0$  period within the genetic unit on distri-

butional groups: (1) /TUA-/; (2) /TAI-/; (3) /TEI-/; and (4) /TAOKETE/; number 4, we suggest as a possible loan form, from Fiji-Melanesia, of relatively recent origin. The vast majority of contemporary labels for sibling categories are formed from the remaining three forms, by the addition of endings (e.g., /-na/ /-ne/) or concatenation of modifying forms (e.g., /*fafine*/, /*tane*/ or some phonemic variant).

Firth (1970:279, note 14) suggests "a relation" between the forms /*tei*-/ and /*tai*-/ which we reject; it appears that these are two contrasting morphs of considerable vintage within Polynesian, the latter quite clearly being a form related to the contemporary Samoan word /*aiga*/, "relative," etc. (see Goodenough 1955, etc.).

While it is plausible to posit these three forms for a proto-language, we note that /*tei*-/ alternates with /*tai*-/ and we suggest that it is reasonable to suppose a two term proto terminology.

A reconstruction of a two term system for the proto language yields exactly three possible types of sibling terminology, according to our theory:  $|| \mid x, \frac{e}{y},$  or  $m \mid f$ . The first two are candidates, we believe, while the latter is excluded as a probable prototype on the grounds of our theory of evolution by successive binary partition (that is, none of the observed types are derivable from it). Both acceptable types have about equal plausibility; the Marquesan-Tuamotuan-Samoan evidence argues for the latter; while all other types in the sample appear derived from the former. (It is quite possible, in our view, that these two types represent a dual prototype dating back to the initial settlement and dispersal of Polynesians possibly in Tonga and Samoa; see Kirk and Epling 1972.)

It is of interest to note here that according to our analysis, the seven societies that display the form /*tai*-/ for the  $||$  category (Table I) are very likely all outlier colonies of Samoan origin and relatively recent origin (with the exception, possibly, of Kapinga). It may be that in the process that encompassed the colonializations referred to the

colonists adopted a new form (/*tai*-/ for the  $||$  /*e* category in contrast to /*tua*/) which became X and also deleted the /*tei*-/ form from the sibling lexicon.

The suggested unit-wide trend toward greater and greater differentiation of the sibling categories with increasing "cognitive" complexity and information (H) is entirely consonant with evolutionary hypothesis of e.g., Goldman (1955) and Sahlins (1958). Even our highly selected sample seems sufficient to indicate this. The apparent florescence of Polynesian civilization, with its associated elaborate social ranking systems, beginning monumental-ceremonial architecture, etc., may be seen among those societies which today constitute Eastern Polynesia. On the other side of the taxonomic fence, Western Polynesian societies display maximum variation, ranging from devolution in the case of some colonial outliers to a near unique parallel florescence in the case of Samoa.

## NOTES

<sup>1</sup> The system of all partitions which forms the taxonomic and phylogenetic space is an exemplification of a mathematical system known as a matroid lattice, and the properties of matroid lattices hold for it.

One of the properties of special interest here is that of chains, from the upper bound ( $\square$  in the present case) to some lower bound (in this case the greatest lower bound,  $\square\square\square$ ).

The phylogenetic problem is to choose the chain which best represents the evolution within the genetic unit, out of all possible chains. The number of distinct chains (c) in lattice  $S^m$  is given by the expression

$$c = \frac{m!(m-1)!}{2^m - 1}$$

For example, where  $m = 4$ ,  $c = 18$ ;  $m = 8$ ,  $c = 1,587,600$ . A chain from  $L^m$  to  $L^1$  (or  $L^1$  to  $L^m$ ) is any set of elements  $L_1, L_2, \dots, L_n$  of  $S^m$  such that  $L^m = L_1 \leq L_2 \leq \dots \leq L_n = L^1$ . Two chains are distinct if one contains at least one element not in the other. The number of distinct chains in the system  $S^m$  is:

$$\frac{m(m-1)^2(m-2)^2 \dots 2^2 1}{2^{m-1}}$$

$$= \frac{m!(m-1)!}{2^{m-1}}$$

See Birkhoff (1967).

<sup>2</sup> Accurate description and classification of events play a fundamental role in ethnology as in all sciences. It is a bit disconcerting to the analyst when social, linguistic, or cognitive events are treated with apparently considerably less respect than the events of other sciences. We have no solution to this problem save mention of it with examples, however.

In our survey of Polynesian sibling terminologies we have encountered a few discrepancies. For example, Murdock (1968:20) lists Tonga as having a terminology conforming to his type F(1), i.e.,  $\square\square$  based on a report referring to about 1850. Murdock (1970:196) next lists Tonga as having a terminology of his new type, O (Jivaran), which presumably is  $\square\square$ , with no time indicated. The lack of concordance ( $\square\square$  vs.  $\square\square$ ) is not mentioned. Firth, another Polynesian expert (1970:275), shows Tonga as  $\square\square$ ! Nerlove and Romney (1967 and personal communication) list Samoa as  $\square\square$  but on their original data card show Samoa as  $\square\square$ . They have no explanation for the discrepancy. Moreover, these workers consulted the same source as did Firth and Murdock (i.e., Mead 1930), which leaves little doubt that Samoans have (had) a term, *tei*, with a clearly stated denotation, younger sibling. Firth (1970:275) cheerfully lists Samoa as type  $\square\square$ , and then spends a good deal of time in print (1970:278-279), discussing a system such as  $\square\square$  and is (1970:278-279) quite aware that the Samoan term *tei* has as its primary denotation *younger sibling*, not *younger parallel sibling*. Furthermore, Firth (1970:274) lists Tikopia as having a terminology of type  $\square\square$ . This is congruent with his 1936 description. However, not to be slighted for novelty, Firth (1970:279, note 14) proceeds to tell us that the Tikopia have a word for "younger sibling" (*taina*—see Table I) and also another similar term (*teitai*) "youngest sibling."

Incidentally, we can find no specific reference to these phenomena in Firth's (1936) original report on Tikopia kinship terms.

A preliminary analysis of the Nerlove-

Romney (1967) classifications of 245 sibling terminologies (Romney kindly made the original data sheets available) against the intersecting cases in Murdock (1968 and Ethnographic Atlas) reveals about an eighty percent agreement as to type of sibling terminology. Such lack of agreement, and the high variance that is implied, is a hindrance to meaningful quantitative analysis such as we have attempted. Table VIII illustrates some of the discrepancies in the Polynesian data of which we are aware.

The table gives type of sibling terminology by Society/Language, after Murdock (1967, 1968, 1970) and Nerlove and Romney (1967). (The number in the Murdock 1968 column indicates the date of ethnographic present of the ethnographic source used by Murdock and presumably Nerlove and Romney.) Murdock (1968:3) specifically *omits* "partial age distinctions" in his type F terminologies ( $\square\square = F(1)$   $\square\square = F(2)$  etc.) where they are often  $\square\square$ .

The discriminating investigator will of course note that Murdock's 1970 determinations differ radically with those he made in 1968 (presumably from the same sources). In particular, they will have noted that three of the fifteen societies dealt with in Murdock (1970) are shown as having a type of terminology, heretofore unique in Oceania, which is the mirror image of all other determinations, by both Murdock (1968) and others (except in the case of Pukapuka, where, between 1968 and 1970, Murdock discovers another dimension). In 1970, Tonga is shown as having the mirror image system to those of Samoa, Pukapuka, and Tokelau. Also, another novelty occurred in 1970, namely, a new type for Polynesia  $\square\square$  (Easter, Marquesas).

That an inadequate classification system may contribute to the confusion is suggested by scrutiny of his descriptions of his types N (Malagasy) and O (Jivaran) (Murdock 1970: 174-175):

*N Malagasy Pattern.* Three terms, distinguished by relative sex and for siblings of the speaker's sex also by sex, which can be glossed as "sibling of the speaker's sex," "brother (ws)," and "sister (ms)."

*O Jivaran Pattern.* Three terms, distinguished by relative sex and for siblings of the opposite sex also by sex, which can be glossed as "brother (ms)," "sister (ws)," and "sibling of the opposite sex."

The misinterpretation of the types, and

TABLE VIII.

	Murdock (1968 and EA)	Murdock (1970)	Nerlove-Romney (1967)	Epling, Kirk, and Boyd Reconstructions A.D. 1900
1. Kapinga, 1910	A	E		
2. O-Java, 1920	F1	K		
3. Rennell, 1960's	F2	F		
4. Tikopia, 1930	F1	K		
5. Samoa, 1920	F2	N		
6. Pukapuka, 1930	F1	N		
7. Tonga, 1850	F1	O		
8. Ellice, 1890	F1	K		
9. Tokelau, 1900	F2	N		
10. East Uvea, 1830	F1			
11. East Futuna, 1840	F1			
12. Niue, 1840	F2			
13. New Zealand, 1820	F2	G		
14. Marquesas, 1900	F2	B		~
15. Mangaia, 1820	F2	G		
16. Mangareva, 1900	F2	G		
17. Hawaii, 1800	F2			
18. Manahiki, 1850	F2			
19. Raroia, 1900	F2			
20. Tahiti, 1900	F2			
21. Easter, 1860	B	B		
22. Tongareva	F2			
23. Raratonga	—	G		
24. Nukuoro	—			
25. Tuamotu	—			
26. Rapa	—			

the resulting confusion, and error of fact, results from Murdock's error of reversing the *gloss descriptions* of the kin types for types N and O!

<sup>3</sup>It needs here to be pointed out that our entire analysis of Polynesian sibling terminology is at best only a very rough first approximation, both taxonomically and phylogenetically. As mentioned above, the descriptions available for sibling terminologies of Polynesian societies are a bit shaky. This seems particularly so as regards dating of the systems and obviously this plays a key role in any phylogenetic argument. We have treated our sample as a synchronic one of Polynesia. This may not be justified, i.e., two contrasting descriptions of the same society and its terminology. (i.e., the Tongan case, which has the terminology as □□ in the 1850s and as □□□ in the twentieth century) may very well be a case of change. We are at this time not able to say much more than this.

#### REFERENCES CITED

- Beaglehole, E. P.  
1938 *Ethnology of Pukapuka*. Bulletin 150. Honolulu: B. P. Bishop Museum.\*
- Biggs, B.  
1966 *English-Maori Dictionary*. Wellington: Reed.\*
- Birkhoff, G.  
1967 *Lattice Theory*. Third ed. Providence: American Mathematical Society.
- Bruner, J. S., J. J. Goodnow, and G. A. Austin  
1956 *A Study of Thinking*. New York: John Wiley and Sons.
- Buck, P. H.  
1932a *Ethnology of Manahiki and Raka-hanga*. Bulletin 99. Honolulu: B. P. Bishop Museum.\*  
1932b *Ethnology of Tongareva*. Bulletin 92. Honolulu: B. P. Bishop Museum.\*  
1934 *Mangaian Society*. Bulletin 122. Honolulu: B. P. Bishop Museum.\*  
1938 *Ethnology of Mangareva*. Bulletin 157. Honolulu: B. P. Bishop Museum.\*
- Burrows, E. G.  
1936 *Ethnology of Futuna*. Bulletin 138. Honolulu: B. P. Bishop Museum.\*  
1937 *Ethnology of Uvea*. Bulletin 145. Honolulu: B. P. Bishop Museum.\*
- 1938 *Western Polynesia: A Study in Cultural Differentiation*. *Ethnologiska Studier* 7:1-19.
- Danielsson, B.  
1956 *Work and Life on Raroia*. London: Allen and Unwin.\*
- Eilers, A.  
1934 *Inseln un Ponape*. In *Ergebnisse der Sudsee Expedition, 1908-1910*. Georg Thilenius, Ed. Hamburg: L. Friedrichson.\*
- Elbert, S., and T. Monberg  
1965 *From Two Canoes*. Honolulu: University of Hawaii Press.\*
- Emory, K. P.  
1965 *Kapingamarangi: Social and Religious Life of a Polynesian Atoll*. Bulletin 228. Honolulu: B. P. Bishop Museum.\*
- Firth, R.  
1936 *We, the Tikopia*. London: Allen and Unwin.  
1970 *Sibling Terms in Polynesia*. *Journal of the Polynesian Society* 79:272-287.
- Gifford, E. W.  
1929 *Tongan Society*. Bulletin 8. Honolulu: B. P. Bishop Museum.\*
- Goldman, I.  
1955 *Status Rivalry and Cultural Evolution in Polynesia*. *American Anthropologist* 57:680-690.
- Goodenough, W. H.  
1955 *A Problem in Malayo-Polynesian Social Organization*. *American Anthropologist* 57:71-83.
- Hale, H.  
1968 *Ethnography and Philology*. In *United States Exploring Expedition, Vol. 6*. Ridgewood: Gregg. [1846]
- Handy, E. S. C.  
1923 *The Native Culture of the Marquesas*. Bulletin 9. Honolulu: B. P. Bishop Museum.\*  
1930 *History and Culture of the Society Islands*. Bulletin 79. Honolulu: B. P. Bishop Museum.\*
- Hogbin, I.  
1931 *The Social Organization of Ontong-Java*. *Oceania* 1:339-425.\*
- Johnson, S. C.  
1967 *Hierarchical Clustering Schemes*. *Psychometrika*. 32:241-254.
- Kennedy, D. G.  
1931 *Field Notes on the Culture of Vaitupu, Ellice Islands*. *Polynesian Society Memoir* 9. Wellington: Polynesian Society.\*
- Kirk, J., and P. J. Epling  
1972 *The Dispersal of the Polynesian Peoples*. Working Papers in Methodol-

\*These are the primary sources for the sibling terminologies in Table I.

- ogy No. 6. Chapel Hill: Institute for Research in Social Science.
- 1973 Taxonomy of the Polynesian Languages. *Anthropological Linguistics* 15:42-70.
- Loeb, E. M.  
1926 History and Traditions of Niue. *Bulletin* 32. Honolulu: B. P. Bishop Museum.\*
- MacGregor, G.  
1937 Ethnology of Tokelau Islands. *Bulletin* 146. Honolulu: B. P. Bishop Museum.\*
- Marsh, R. M.  
1967 *Comparative Sociology*. New York: Harcourt, Brace and World.
- Mead, Margaret  
1930 Social Organization of Manua. *Bulletin* 76. Honolulu: B. P. Bishop Museum.\*
- Metraux, A.  
1940 Ethnology of Easter Island. *Bulletin* 160. Honolulu: B. P. Bishop Museum.\*
- Morgan, L. H.  
1871 Systems of Consanguinity and Affinity of the Human Family. *Smithsonian Contributions to Knowledge*, Vol. 17. Washington: Smithsonian Institution.\*
- Murdock, G. P.  
1967 *Ethnographic Atlas: A Summary*. *Ethnology* 6:109-236.  
1968 Patterns of Sibling Terminology. *Ethnology* 7:1-24.  
1970 Kin Term Patterns and Their Distribution. *Ethnology* 9:165-207.
- Nerlove, S., and A. K. Romney  
1967 Sibling Terminology and Cross Sex Behavior. *American Anthropologist* 69:179-187.
- Pawley, A.  
1966 Samoan Phrase Structure. *Anthropological Linguistics* 8:1-63.
- Roberts, J. M., and D. Schneider  
1956 *Zuni Daily Life*. Laboratory of Anthropology, University of Nebraska.
- Sahlins, M. D.  
1958 *Social Stratification in Polynesia*. Seattle: University of Washington Press.
- Sharp, A.  
1964 *Ancient Voyagers in Polynesia*. Berkeley: University of California Press.
- Williamson, R. W.  
1924 *The Social and Political Systems of Central Polynesia*. 3 volumes. Cambridge: Cambridge University Press.