

# Lawrence Berkeley National Laboratory

## Lawrence Berkeley National Laboratory

### Title

POLARIZATION IN PROTON-PROTON SCATTERING USING A POLARIZED PROTON TARGET.  
PART I. 0.330 TO  
0.740 GeV. PART II. 1.70 TO 6.15 GeV.

### Permalink

<https://escholarship.org/uc/item/9tz8v8bg>

### Authors

Betz, F.  
Arena, J.  
Dost, H.  
et al.

### Publication Date

1966-04-01

UCRL-16866

**University of California**  
**Ernest O. Lawrence**  
**Radiation Laboratory**

**POLARIZATION IN PROTON-PROTON SCATTERING  
USING A POLARIZED PROTON TARGET**

**PART I. 0.330 TO 0.740 GeV**

**PART II. 1.70 TO 6.15 GeV**

**TWO-WEEK LOAN COPY**

*This is a Library Circulating Copy  
which may be borrowed for two weeks.  
For a personal retention copy, call  
Tech. Info. Division, Ext. 5545*

**Berkeley, California**

Stoveybrook High Energy Conference-  
State Univ., Stoveybrook, Long Is-  
land, N.Y. -April 22-23, 1966  
(Proceedings)

UCRL-16866

UNIVERSITY OF CALIFORNIA

Lawrence Radiation Laboratory  
Berkeley, California

AEC Contract No. W-7405-eng-48

POLARIZATION IN PROTON-PROTON SCATTERING  
USING A POLARIZED PROTON TARGET  
PART I. 0.330 TO 0.740 GeV

F. Betz, J. Arens, H. Dost, M. Hansroul,  
L. Holloway, C. Schultz, G. Shapiro, W. Troka

PART II. 1.70 TO 6.15 GeV

P. Grannis, F. Betz, O. Chamberlain, B. Dieterle,  
C. Schultz, G. Shapiro, H. Steiner, L. Van Rossum, D. Weldon

April 1966

-iii-

Polarization in Proton-Proton Scattering

Using a Polarized Proton Target

Part I. 0.330 to 0.740 GeV

F. Betz, J. Arens, H. Dost, M. Hansroul,

L. Holloway, C. Schultz, G. Shapiro, W. Troka

Part II. 1.70 to 6.15 GeV

P. Grannis, F. Betz, C. Chamberlain, B. Dieterle,

C. Schultz, G. Shapiro, H. Steiner, L. Van Rossum, D. Weldon

## Polarization Parameter in P-P Scattering

Using a Polarized Proton Target

(presented by L. Holloway)

This is a report of the results of two experiments to measure the polarization parameter in p-p scattering.<sup>1,2</sup> Both experiments utilize an unpolarized proton beam incident on a polarized proton target.<sup>3</sup> One experiment was performed at the Berkeley 184-inch cyclotron using incident protons of 328, 614, 679, and 736 MeV kinetic energy. The other experiment was performed at the Fevatron and measurements were taken at 1.7, 2.85, 3.5, 4.0, 5.05, and 6.15 GeV kinetic energy. The angular regions measured were from  $20^\circ$  to  $100^\circ$  center of mass; the square of the four-momentum transfer ranged from 0.1 to 0.8  $(\text{GeV}/c)^2$ .

### I. Experimental Method

The polarized proton target used in these experiments consisted of four single crystals of  $\text{La}_2\text{Mg}_3(\text{NO}_3)_{12} \cdot 24\text{H}_2\text{O}$  in which approximately one percent  $\text{Nd}^{142}$  had been added. The hydrogen content was about 3% by weight and the hydrogen thickness was  $0.15 \text{ g/cm}^2$ . The free protons in the waters of hydration were polarized by the dynamic-nuclear-polarization technique<sup>4</sup>, which for this experiment involved immersion of the target in a  $1.2^\circ\text{K}$  liquid helium bath inside a constant magnetic field of 18.75 kilo gauss. The appropriate "forbidden" transitions were excited by microwave radiation at about 71 kMc. A small variation in the microwave frequency made it possible to reverse the direction of the proton spins.

The polarization was monitored by measuring the strength of the

proton nuclear magnetic resonance signal at a frequency of about 80 Mc. This signal appeared as the change in voltage across a coil surrounding the target crystals through which a constant current rf source was applied. As the rf frequency was swept across the NMR frequency the absorption of the rf power by the protons changed the Q of the coil and hence the voltage across it. Every 12 hours or so the microwaves would be turned off and the proton spins allowed to come to thermal equilibrium. The thermal equilibrium polarization, about 0.15%, was then measured and used as a calibration of the NMR detection apparatus. The magnitude of the target polarizations for these experiments ranged from 20% to 60%. The direction was changed every hour or so to minimize systematic errors due to beam geometry or detection efficiency changes.

Figure 1 shows the experimental arrangement. Elastic p-p scatters were detected by a coincidence in one of the 10 up-array counters and one of the 10 down-array counters. A count was scored in a coded bin of a 100-channel analyzer for each event detected, as an element of a 10x10 matrix. The dimensions of the counters and their distances were chosen to maximize the ratio of the elastic p-p scatterings to the background, consistent with the desired angular resolution and counting rate. Since quasi-elastic scatterings of protons in the beam with protons in the nuclei of the non-hydrogen elements of the target were prime contributors to the background, advantage was taken of the fact that these protons in the nuclei have an average Fermi momentum of 200 (MeV/c). The orientation of this momentum is random, and its effect is to smear out the trajectories of the scattering particles through an angle

$$\theta \sim 200 \text{ (MeV/c) } P \text{ (MeV/c) .}$$

In addition background data were taken with the crystals replaced by a dummy target that contained hydrogen free elements simulating the heavy nuclei of the real crystal.

An experimental measurement of  $P(\theta)$ , at a given energy, consisted of storing elastic p-p events under conditions in which only the sign and magnitude of the target polarization were allowed to change. Figure 2 shows an example of elastic-to-background counting ratio at 6 GeV.

The polarization parameter  $P(\theta)$  is related to the p-p differential scattering cross section by

$$\left(\frac{d\sigma}{d\Omega}\right)_{\text{pol}} = \left(\frac{d\sigma}{d\Omega}\right)_{\text{unpol}} \left[1 + P(\theta)P_T\right] \tag{1}$$

where  $P_T$  is the target polarization. The data were analyzed by means of a least squares fit to equation (1) after a proper background subtraction was made.

### II. Results

The results of the measurement are shown graphically in Figs. 3 through 5. The error flags indicate statistical counting errors only. In the high energy data a relative systematic error (RSE) has been indicated which includes the error arising from the thermal equilibrium polarization measurement and a non-uniform target polarization correction. Figure 6 is a plot of the maximum polarization as a function of beam energy.

### III. Discussion

A Regge pole model of elastic p-p scattering predicts that in the limit of high energy the polarization parameter is given by

$$P \sim S^{(\alpha_n - \alpha_p)}$$

Here  $S$  is the total energy squared and the expression is to be evaluated at a fixed value of the four-momentum transfer  $t$ .  $\alpha_p$  and  $\alpha_n$  are the positions of the Pomeron and its nearest neighbor at low momentum transfer. Figure 7 shows a fit to the slopes  $\frac{d(\log P)}{d(\log S)}$ . While the fits are not too good they certainly do not disagree with the Regge hypothesis. If we assume the leading pole is on the Pomeron trajectory then the interfering trajectory seems to have a value at  $t=0$  of about  $0.25 \pm 0.35$ .

It should be pointed out that we are certainly not in the "asymptotic" energy region and should not expect perfect agreement.



References

1. Polarization Parameter in p-p Scattering from 328 to 736 MeV.  
 F. Betz, J. Arens, O. Chamberlain, H. Dost, P. Grannis, M. Hansroul,  
 L. Holloway, C. Schultz, and G. Shapiro  
 UCRL 16749 (to be published in Physical Review).
2. Polarization Parameter in p-p Scattering from 1.7 to 6.1 BeV  
 P. Grannis, J. Arens, O. Chamberlain, B. Dieterle, C. Schultz,  
 G. Shapiro, H. Steiner, L. Van Rossum, and D. Weldon  
 UCRL 16750 (to be published in Physical Review).
3. C. H. Schultz, Ph.D. thesis (University of California), UCRL 11149  
 (unpublished).
4. C. D. Jeffries, Dynamic Nuclear Orientation, Interscience, New York,  
 1963.

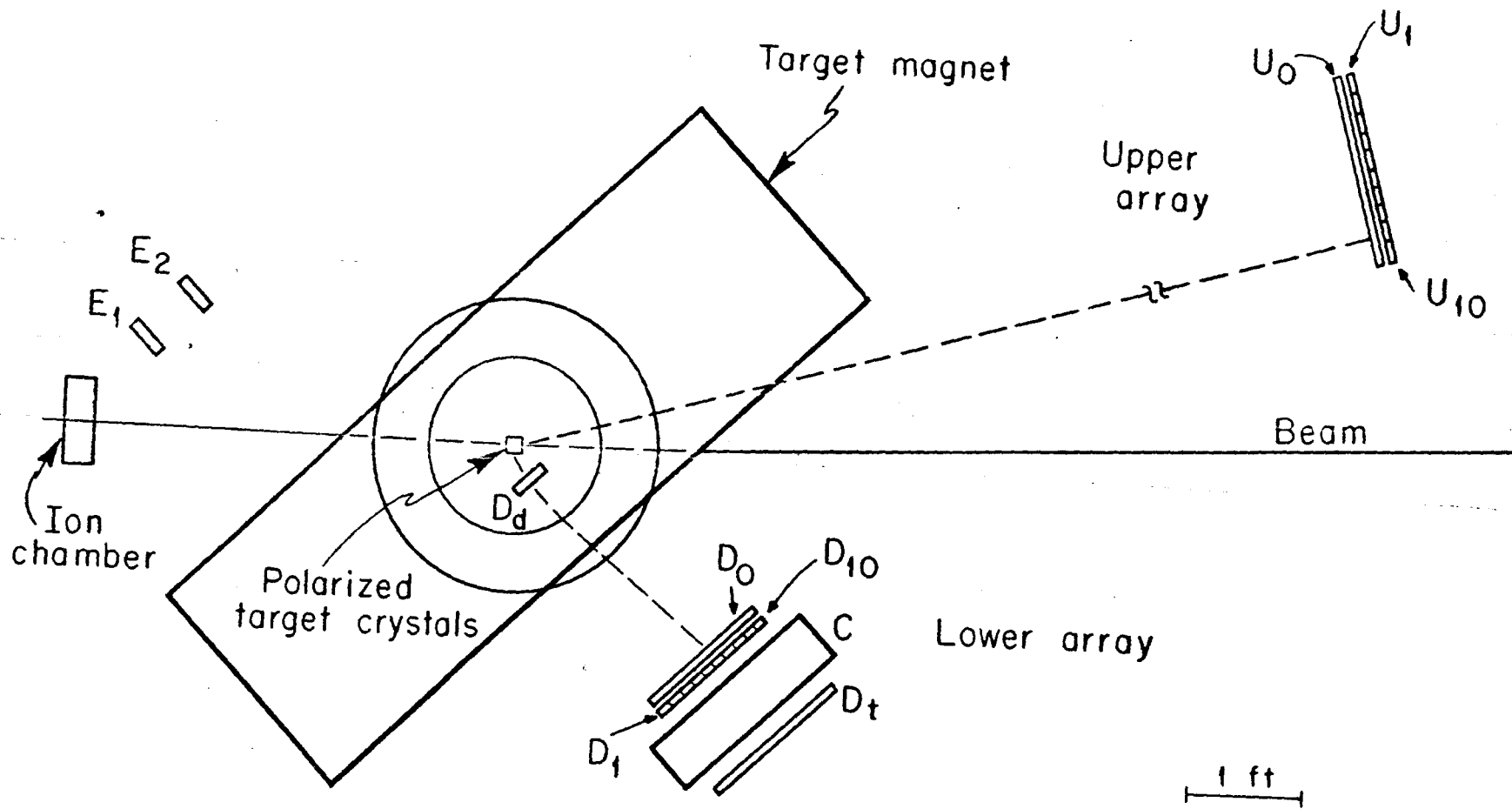

-6-

MU-35856

UCRL-16866



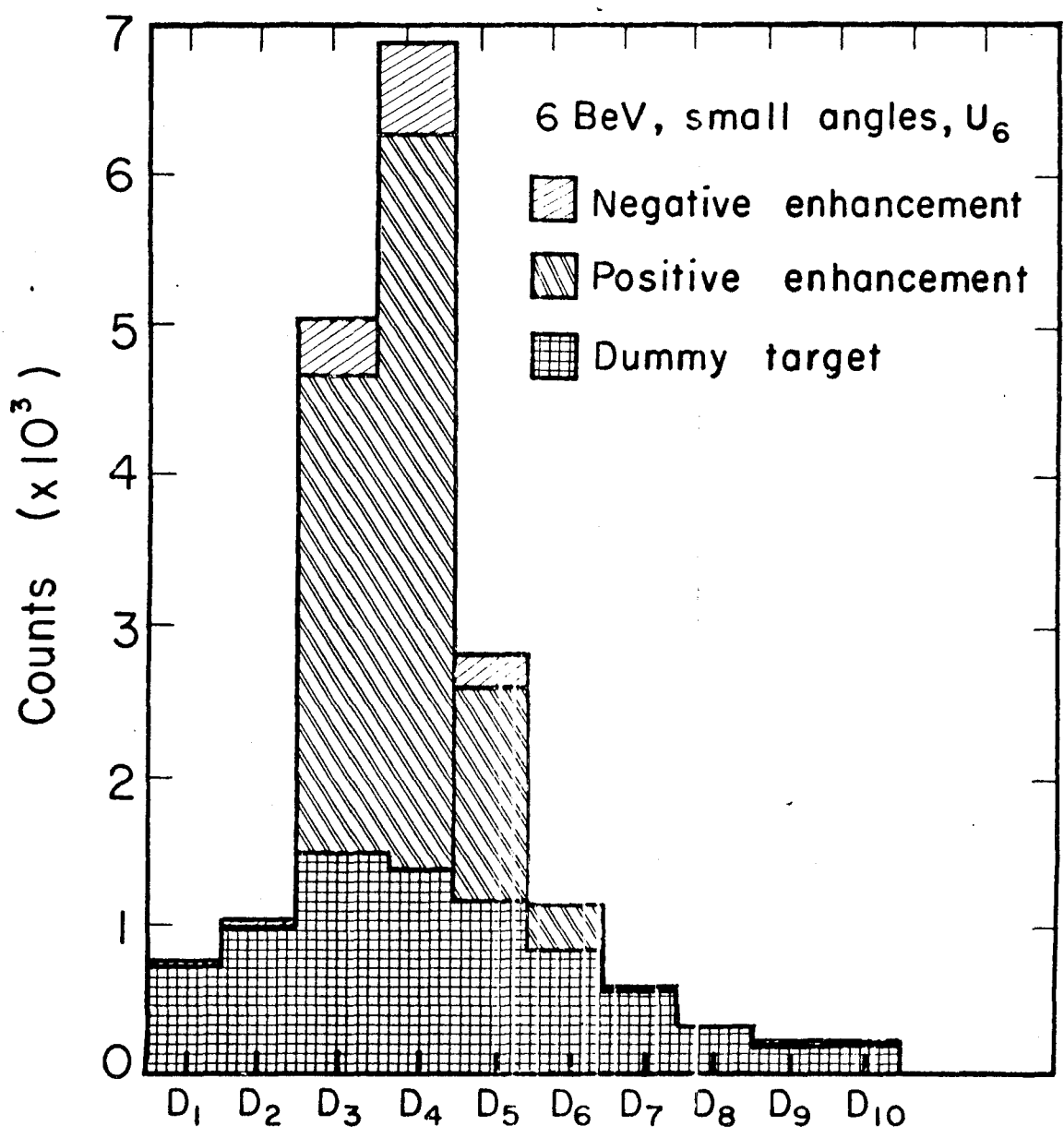

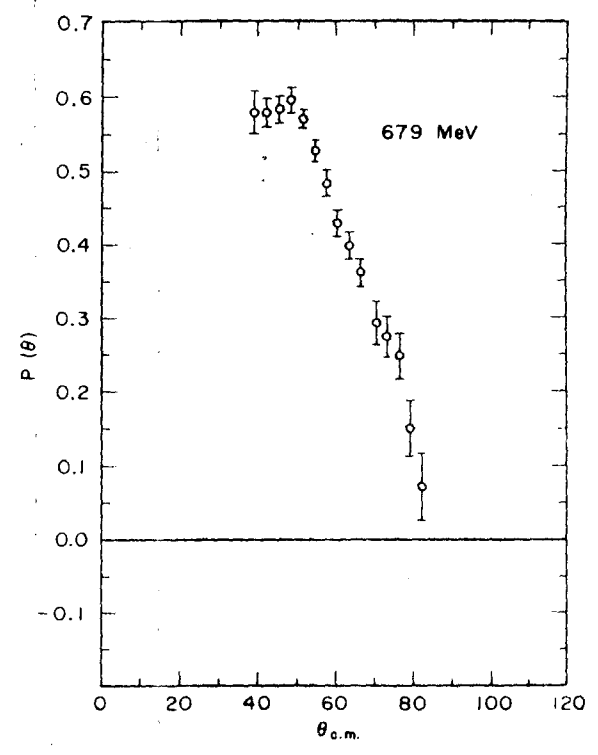
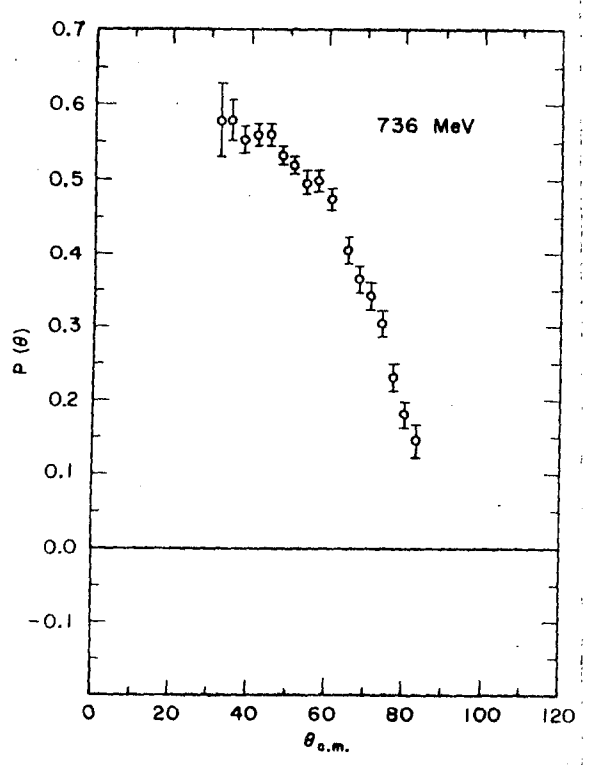
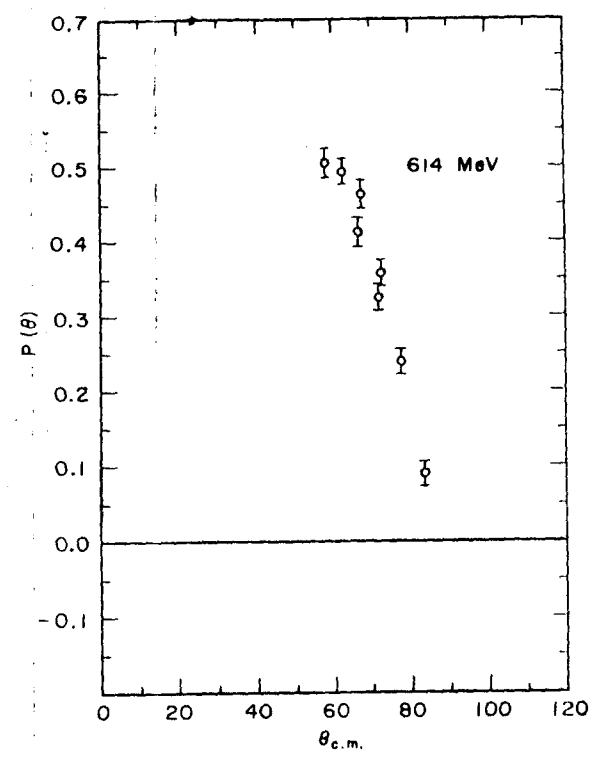
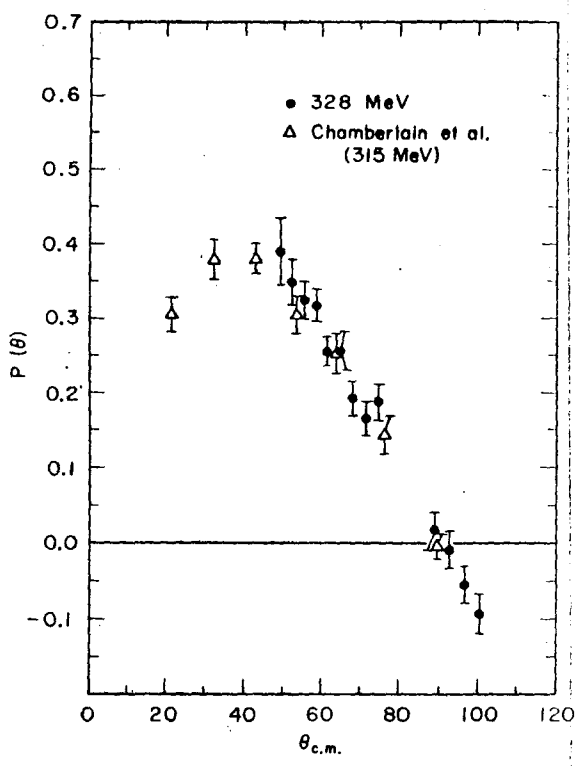

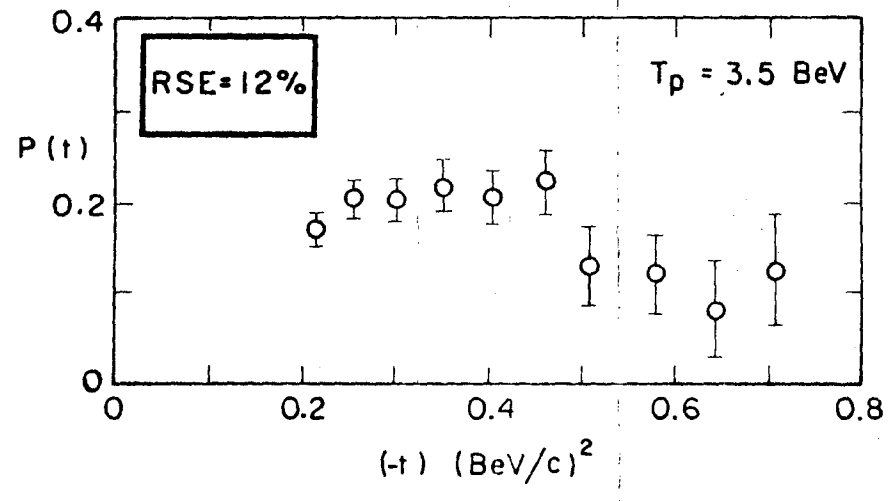
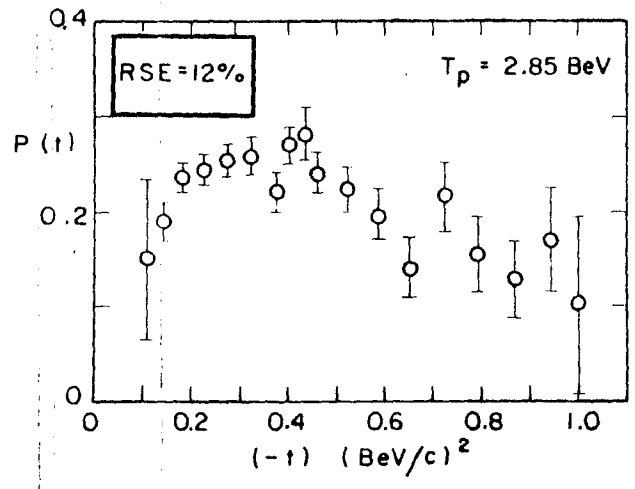
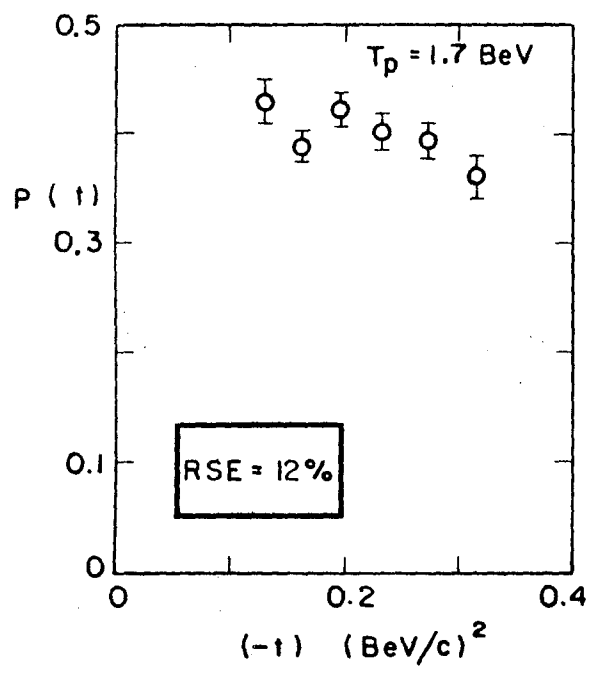

LBL

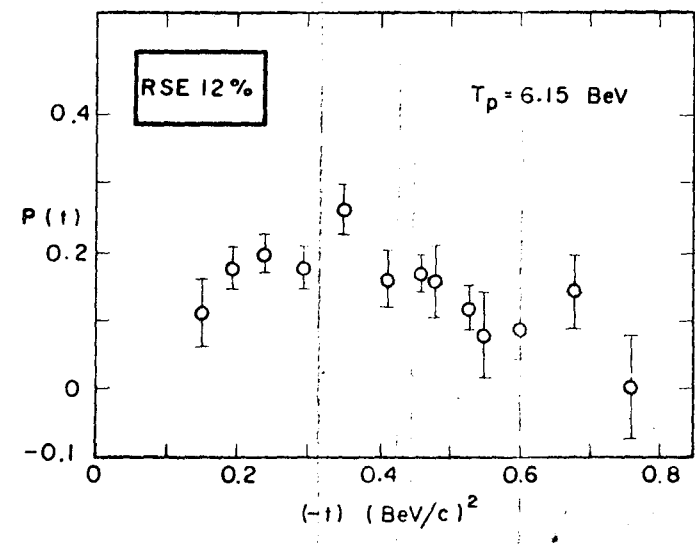
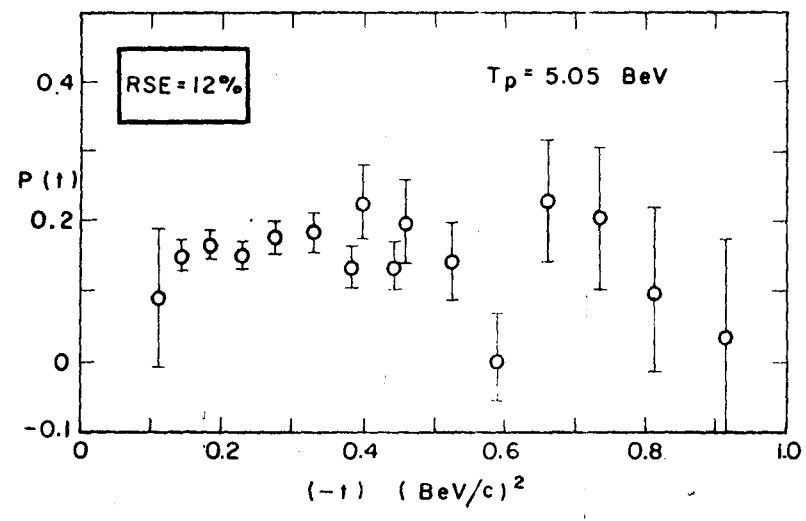
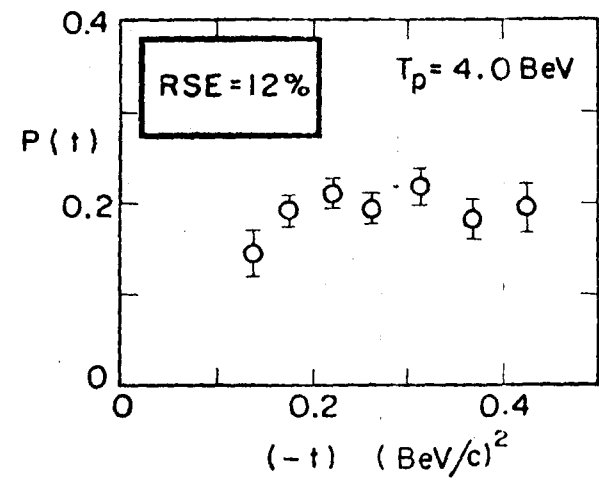

100

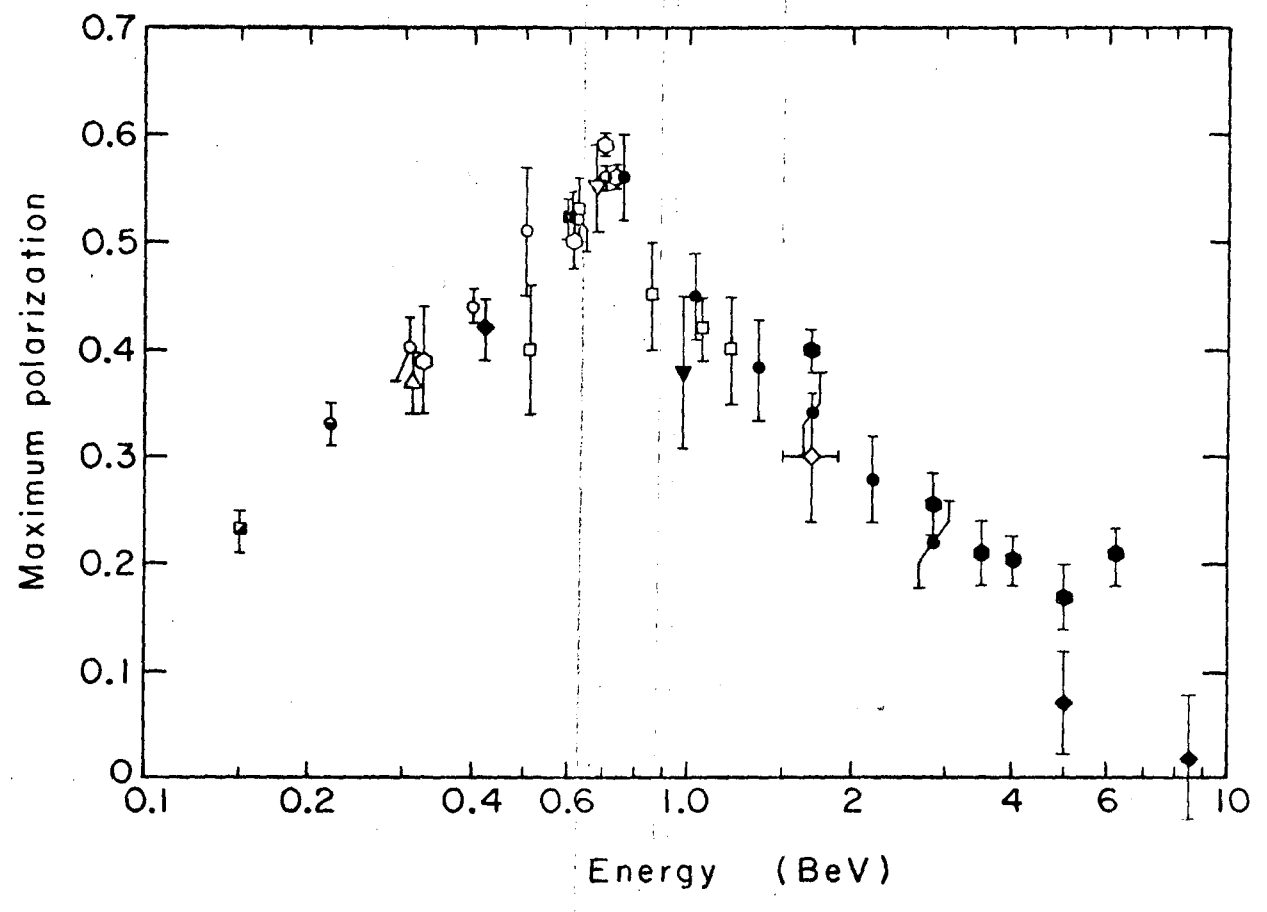

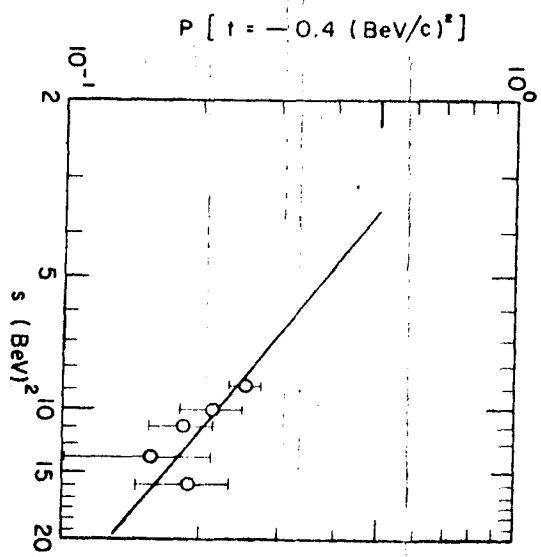
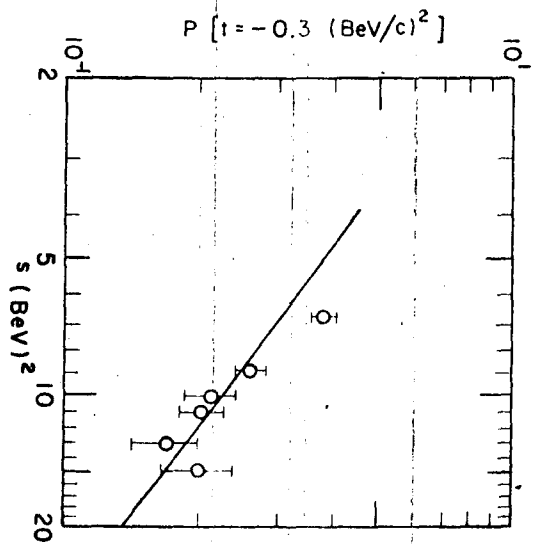
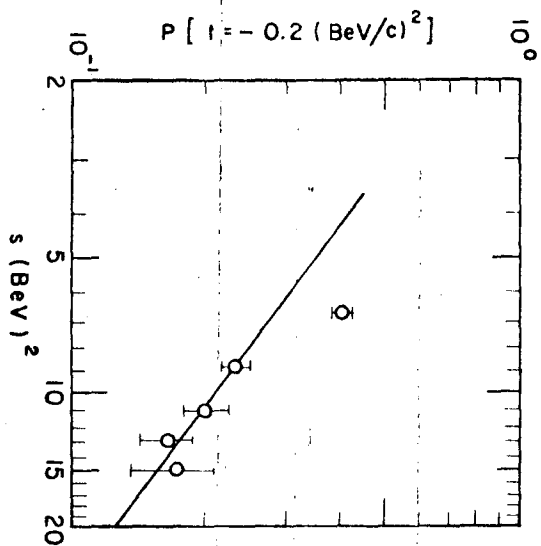



This report was prepared as an account of Government sponsored work. Neither the United States, nor the Commission, nor any person acting on behalf of the Commission:

- A. Makes any warranty or representation, expressed or implied, with respect to the accuracy, completeness, or usefulness of the information contained in this report, or that the use of any information, apparatus, method, or process disclosed in this report may not infringe privately owned rights; or
- B. Assumes any liabilities with respect to the use of, or for damages resulting from the use of any information, apparatus, method, or process disclosed in this report.

As used in the above, "person acting on behalf of the Commission" includes any employee or contractor of the Commission, or employee of such contractor, to the extent that such employee or contractor of the Commission, or employee of such contractor prepares, disseminates, or provides access to, any information pursuant to his employment or contract with the Commission, or his employment with such contractor.