

Lawrence Berkeley National Laboratory

Recent Work

Title

A MICROCOMPUTER SYSTEM FOR REAL-TIME MONITORING and CONTROL OF GAS CHROMATOGRAPHS

Permalink

<https://escholarship.org/uc/item/9nz444kn>

Author

Donaghey, L.F.

Publication Date

1976-04-01

A MICROCOMPUTER SYSTEM FOR REAL-TIME
MONITORING AND CONTROL OF GAS CHROMATOGRAPHS

L. F. Donaghey, G. M. Bobba, and D. Jacobs

April 1976

RECEIVED
APR 14 1976
BERKELEY LABORATORY

LIBRARY AND
DOCUMENTS SECTION

Prepared for the U. S. Energy Research and
Development Administration under Contract W-7405-ENG-48

For Reference

Not to be taken from this room

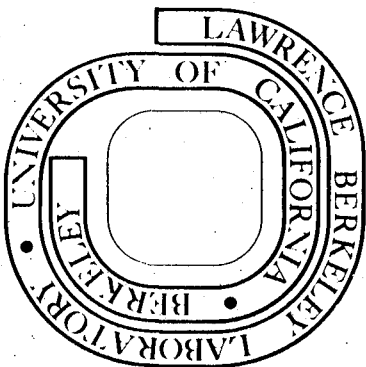

LEGAL NOTICE

This report was prepared as an account of work sponsored by the United States Government. Neither the United States nor the United States Energy Research and Development Administration, nor any of their employees, nor any of their contractors, subcontractors, or their employees, makes any warranty, express or implied, or assumes any legal liability or responsibility for the accuracy, completeness or usefulness of any information, apparatus, product or process disclosed, or represents that its use would not infringe privately owned rights.

DISCLAIMER

This document was prepared as an account of work sponsored by the United States Government. While this document is believed to contain correct information, neither the United States Government nor any agency thereof, nor the Regents of the University of California, nor any of their employees, makes any warranty, express or implied, or assumes any legal responsibility for the accuracy, completeness, or usefulness of any information, apparatus, product, or process disclosed, or represents that its use would not infringe privately owned rights. Reference herein to any specific commercial product, process, or service by its trade name, trademark, manufacturer, or otherwise, does not necessarily constitute or imply its endorsement, recommendation, or favoring by the United States Government or any agency thereof, or the Regents of the University of California. The views and opinions of authors expressed herein do not necessarily state or reflect those of the United States Government or any agency thereof or the Regents of the University of California.

A Microcomputer System for Real-Time Monitoring
and Control of Gas Chromatographs

L. F. Donaghey, G. M. Bobba and D. Jacobs

Materials and Molecular Research Division, Lawrence Berkeley Laboratory
and Department of Chemical Engineering, University of California,
Berkeley, California 94720

April, 1976

Abstract

Microcomputer systems, based on the Intel 8008 and 8080 microprocessors, have been developed to perform real-time, on-line data acquisition and analysis of gas chromatographic data and to control sampling and operation of the gas chromatograph. Real-time analysis is achieved by the novel method of interleaving subprograms for the sequential data acquisition and reduction steps, thereby minimizing memory requirements. The system contains a real-time clock for signal timing, and interfaces to a teletype and digital volt meter. An automated triac controller is used to control the temperature of the gas chromatographic column, while a matrix of relays is able to actuate sampling valves.

Introduction

Automatic control of gas chromatography and on-line analysis of chromatograms have advanced significantly during the past decade owing to technological advances in solid-state science. Since the development of the large-scale digital computer, many studies of the utilization of digital computers in on-line applications have been reported [1-5]. The introduction of the minicomputer in the late 1960's was particularly important to the development of on-line control of the gas chromatograph, and to background data analysis following the recording of the chromatogram in the computer memory [6-8]. The cost of on-line analytical facilities for gas chromatography has been reduced substantially in recent years by the development of low-cost semiconductor memories, and by the miniaturization of thermal and impact printers for automatic reporting of results, yet the overall cost of minicomputer systems is still prohibitive for small laboratory applications to chromatography.

Recently, a significant advance in gas chromatographic science has been made feasible by substantial improvements in large-scale integrated circuit technology, with which it is now possible to produce a sophisticated signal processing circuit on a single silicon chip - a microprocessor. Microprocessor technology has reached the point where it is possible to develop microcomputer systems with the performance range of existing minicomputer-based instruments, but in the cost range of the limited, hardwired process controllers. This new approach promises to efficiently solve the problem of gas chromatograph automation for the small laboratory. Microcomputers have the advantages of high reliability, a high noise immunity,

small size and power requirements and continuous, dedicated service.

The authors have developed bus-oriented, modular microcomputer built around the INTEL 8008 and 8080 microprocessors for real-time, on line gas chromatographic data analysis and also for sampling

control. It is appropriate to point out that, while alternative systems operate in two logically different steps -- on-line (or foreground) data logging and later (or background) data reduction -- the authors tried a completely different approach. Data acquisition and reduction are both performed in real-time under software control, avoiding the storage of nearly all of the gas chromatographic data. Furthermore, the flexible, interface-oriented architecture of this microcomputer system allowed another significant achievement in gas chromatograph instrumentation, until now featured only in the more sophisticated and expensive systems. This is the totally automated operation of the gas chromatograph, including the sampling procedure, the control of the column temperature as a function of time, and data reduction.

This article describes an easily implemented microcomputer system which allows full automation of gas chromatographs. This approach to gas chromatograph automation has significant utility for the research laboratory where flexible software structure and simultaneous on-line analysis and control are desired.

The Microcomputer System

A microcomputer system based on the Intel 8008 microprocessor was constructed using the bin-oriented modular approach developed at the Lawrence Livermore Laboratory [9]. In this system, logic cards supporting integrated circuits are connected together by a forty-wire bus which controls input, output, memory storage and timing functions. The modular approach is ideal for trouble-shooting

and for adaptability to different control processes. The overall system is shown schematically in Fig. 1.

The heart of the system is an Intel 8008, 1-chip microprocessor organized on three 5 by 3 inch modular printed circuit boards, which are shown in Fig. 2. A similar microcomputer system based on the Intel 8080 microprocessor requires two modular circuit boards for the microprocessor, clock circuit and input-output control. Other circuits occupy additional modules within the bin. A restart board allows an easy recovery from default conditions as well as a means for initializing the system program. The expandable, 21-shot bin contains special connectors which are wire-wrapped to provide blocks for similar cards such as programmable read-only-memory (PROM), random-access memory (RAM), and input-output circuits. In the present configuration, the microprocessors can directly access 64 pages (256 8-bit bytes each) of RAM or PROM in any combination, eight input, and eight output ports, each of eight bits. A typical interface circuit fits on a standard board. Special circuits of the microcomputer system are summarized in Table I.

Each entire system consisting of a microcomputer bin, power supplies, digital voltmeter and 8-LED control status indicator is contained within a one-cubic foot volume. Control relays and an A/D converter are located in two remote connection boxes for automatic control of the sampling values of the gas chromatograph and for high-speed data acquisition.

Special-purpose circuits were constructed for the present application. These include a real-time clock, a digital voltmeter (DVM) interface, a process-control signal latch, and control relay circuit. In addition, the system contains standard circuits for data output to a teletype, analog-to-digital and digital-to-analog

Table I

Special Circuits of the Microcomputer Systems
for Gas Chromatography

Serial asynchronous transmitter-receiver interface

Digital voltmeter interface (4 1/2 digits)

Solid-state dc relay interface (24 relays)

Solid-state ac power relays (2 relays)

Resettable real-time clock, binary, 8-bits

Analog-to-digital converter (ADC), 12-bits, with 0 to 10 V input range

Digital-to-analog converter (DAC), 12 bits, with 25 μ s settling
time and a ± 10 V output range

Push-Pop memory stack for register storage at breakpoints (16 byte)

conversion. The real time clock circuit board and the universal asynchronous transmitter-receiver (UART) module are shown in Fig. 3. The real time clock allows control programs to be operated at rates from 0.5 to 64 Hz. The UART allows serial transmission of data between the data bus and an ASR 33 teletype. Special interface modules for controlling sampling values and for interfacing to a digital panel meter are shown in Fig. 4.

An important feature of the microcomputer controller is the direct digital control (DDC) of the column heater. Although power control by microcomputer has been described earlier by Siem [10] using a stepping motor and variac, a method offering greater precision and low cost is the combination of a digitally controlled timer with a solid-state triac. In the low-cost circuit developed in this study, an 8-bit number representing a time delay is sent to a programmable counter at each zero crossing of the ac network voltage where the triac is turned on. The counter starts a count-up sequence until the carry bit is set, whereupon the counter overflows in a time less than 1/120 sec (half-cycle period). The setting of the carry bit signals the cut-off of the triac. The power output supplied by the triac is linearized by using a 100 delay-increment library stored as a look-up table in the microcomputer memory. This method of power control eliminates the need for a stepping motor and variac or a D/A converter and associated analog controller.

Interface Circuits

A general purpose interface has been developed for interfacing the microcomputer to a number of digital voltmeters with BCD output. This interface, shown in Fig. 5, avoids the use of many inputs by partitioning the parallel BCD data into 8-bit slices. After the digital voltmeter is latched by an output pulse, a single instruction is needed to read the clock status into the accumulator of the microprocessor, or to read a pair of BCD digit lines onto the data bus. This interface has been successful for interfacing the Newport 2000B and Preston 723A digital voltmeters.

An interface for the automatic control of sampling values is shown in Fig. 6. This interface consists of a simple matrix of double-throw, single-pole solid-state relays which are able to carry currents up to 1A. Each double-pole switch is controlled by a single line of one output port, and is actuated by a tri-state latch. The interface includes current drivers for LED indicators which indicate the status of sampling values.

Software

The software structure for automatic control is shown schematically in Figure 7. The subprograms for peak-area integration in chromatograms, column-heater temperature control, and valve control are interleaved in a control time increment of constant duration. Multiple entry points in the subprograms allow program control to be changed from initialization to sampling.

Experimental

The microcomputer system was experimentally tested in separate process-control and analytical studies. The program behavior was thoroughly tested for timing requirements and for performance quality using test routines in conjunction with a Beckman GC-2A gas chromatograph with a thermal conductivity detector.

A first-order digital filter was implemented for noise filtering of both the gas chromatograph detector signal and for the column heater control algorithm. The noise reduction of the detector input was achieved by reading the amplified detector signal n (typically $3 < n < 5$) times in succession and then using the weighted mean

$$E_k = \sum_{i=1}^n f_i E'_i \quad (1)$$

where $f_i \sim 1$, as the input for analysis and control calculations. Noise filtering of the column heater temperature was achieved with filter state equation,

$$E_k = f_1 E_k + (1 - f_1) E_{k-1} \quad (2)$$

where the gain, f_1 , was given the value 0.7. The filters introduce a first-order lag to the data acquisition and control process, but is essential for noise reduction in any noisy environment.

The implementation of a number of DDC algorithms for control of column heaters was achieved with the methods developed by

Jacobs [11]. Two control methods were implemented for automated gas chromatography following simulation studies which showed them to yield sufficiently precise control: proportional-differential-integral (PID) control and finite time setting (Dead Beat) control.

The discrete version of the PID control algorithm used in control studies was given by

$$C_k = \underbrace{K_P E_k}_P + K_I \underbrace{\sum_{i=0}^k E_i}_I + K_D \underbrace{(E_k - E_{k-1})}_D$$

$$= 88E_k + x_{3,k}$$

$$\text{where } x_{3,k+1} = x_{3,k} + 8E_k,$$

E_k is the control error, and C_k is the k -th control output. The control gain was optimally computed for the column furnace by the open-loop thermal response to a step input. For dead beat control, the recursive form of the algorithm had the form,

$$C_k = D(E_k - Px_{3,k})$$

$$\text{where } x_{3,k+1} = E_k - x_{3,k}$$

Results and Discussion

The execution time of different control subprograms was measured to determine the maximum sampling rate allowed under different operating conditions. The execution time of an integration step of the chromatogram program was found to be about 50 ms with the 8008-based microcomputer, and a factor of about ten faster for the 8080-based system. A single step of the heater

temperature control subprogram required 920 ms with the dead beat algorithm, and a somewhat longer time with PI control in the 8080-based system. The valve control subprogram required 20 ms, which is essentially the settling time of the read switches. Thus, the maximum possible sampling rate was 20 Hz for peak integration alone, and 1 Hz under full control. The use of the Intel 8080 microprocessor in place of the 8008 microprocessor thus allows an increase in sampling and control speeds by a factor of 10, thereby making possible the control of several chromatographs by a single microcomputer controller. The extension of the present control strategy to multiple gas chromatograph control has already been described by the authors [12].

The sampling rates of different input devices was compared to subprogram execution speeds to determine the optimum selection of system components. A comparison of the characteristics of several input devices is given in Table II. Software programs were developed to read, translate into 3-byte floating-point format, and store in RAM at a rate up to 150 Hz. Thus, only the A/D converter speed is limited by the software speed. The 4 1/2 digit voltmeter with a sampling rate of 100 readings s^{-1} offers the optimum matching of operating speed with the analytical software, and allows visual display of the instantaneous data. Because noise reduction by signal averaging was found to be an essential component of the automatic control program, the sampling speed of the digital voltmeter should exceed the software speed by a factor of three to five. Therefore,

Table II

Comparison of Chromatogram Data Input Devices

<u>Input Device</u>	<u>Sampling Speed (reading/s)</u>	<u>Precision (bits)</u>	<u>Advantages</u>
Digital Panelmeter (Newport)	30	4 1/2 digit	Display of instantaneous data for visual monitoring.
Digital Voltmeter (Preston 723A)	100	4 1/2 digit	Data display with moderate sampling speed.
A/D Converter (Analog Devices ADC 12QM)	4000	16 bit	High sampling speed for signal averaging to reduce noise.

the slower latching digital voltmeters cannot be used effectively with the Intel 8080-based microprocessor controller.

A comparison of the memory requirements and control quality of the PI and dead beat control algorithms is shown in Table III. The dead beat control algorithm required the smaller memory requirement, and operated at somewhat higher speed. The dead beat control algorithm also showed the smaller maximum deviation from the set-point under transient conditions, and gave a steady-state control well within required limits for automated control. The control quality obtained under temperature ramp control with the dead beat algorithm is also given for comparison.

The recent advances in the microelectronics technology and the development of microprocessors has made possible the implementation of microcomputer controllers of gas chromatographs. The design presented in this paper should be of significant practical utility in research laboratories.

Conclusion

A microcomputer system designed for automatic analysis and control of gas chromatographs has been studied experimentally and shown to allow automatic real-time data analysis and full control of sampling values and column heater for both temperature ramp and set-point control.

The flexibility of the bus-oriented microcomputer system described was found to be augmented by the design of special purpose modules such as input-output interfaces, value control latches and a real time clock. A software structure in which subprograms are

Table III

Comparison of Heater Control Algorithms

<u>Algorithm</u>	<u>Memory required (bytes)</u>	<u>Steady-state control quality</u>	<u>Maximum transient deviation</u>
PI algorithm	215	$\pm 0.01^{\circ}\text{C}$	$+ 4^{\circ}\text{C}$
Deat beat algorithm	134	$\pm 0.2^{\circ}\text{C}$	1°C
Temperature ramp generator	240	$\pm 1^{\circ}\text{C}$	1°C

interleaved makes possible the acquisition of chromatogram data at fixed time intervals. An optimum system design and sampling rate is presented.

The operating speeds of the Intel 8008 and 8080-based microcomputer systems are compared. It is shown that the 8008-based system is compatible with digital voltmeters having sampling speeds exceeding 20 s^{-1} in chromatogram integration applications. The 8080-based system requires a high-speed A/D converter to prevent sampling rate limitations, and is capable of operating chromatogram integration and column heater control programs simultaneously.

Acknowledgment

The financial assistance of the U.S. Energy Research and Development Administration and of the duPont de Nemours Company are gratefully acknowledged.

References

1. Hadley, J., and Bock, J. L., Process Control Automation 13, 24 (1966).
2. Simon, W., Castelli, W. P., and Rutslein, D. D., J. Gas Chromatog. 5, 578 (1967).
3. Jones, K., McDougall, A. O., and Marshall, R. C., "Gas Chromatography 1966," A. B. Littlewood, ed., The Institute of Petroleum, 1966, p. 376.
4. McCullough, R. D., J. Gas Chromatog. 5, 635 (1967).
5. Briggs, P. P., Control Engineering, p. 76 (Sept. 1967).
6. Gill, J. M., J. Chromatog. Sci. 7, 731 (1969).
7. Hettinger, J., "Comparison of Computing Integrators and Conventional Integrators for Chromatography," Tech. Bull. 111-74, Spectra Physics, Santa Clara, CA (1974).
8. Hendrickson, J. L., Wallace, D., and Baumann, F., "Multi-User Gas Chromatography Data System with Foreground-Background Processing," Tech. Bull. 139-71, Varian Aerograph, Walnut Creek, CA (1971).
9. Fisher, E. R., "Modular Approach to Microprocessors," Tech. Rept. UCRL-75574, Lawrence Livermore Laboratory, Livermore, CA (1974).
10. Seim, T. A., "A Microprocessor Sampled Data Process Controller," Tech. Rept. BNWL-1795, Battelle Pacific Northwest Laboratories.
11. Jacobs, D., and Donaghey, L. F., University of California, Berkeley, to be published.
12. Bobba, G. M., and Donaghey, L. F., Amer. Laboratory 8, 2, 27 (1976).

List of Figures

- Fig. 1 Schematic of a microcomputer system for control and on-line analysis of a gas chromatograph.
- Fig. 2 Modular circuit boards for the Intel 8008-based microcomputer system. Left: input-output control module. Center: central processor module. Right: memory address-storage module with programmable read-only memory for the operating system.
- Fig. 3 Special-function modules. Left: real-time clock module. Right: universal asynchronous transmitter-receiver.
- Fig. 4 Interface modules. Left: valve-control relay interface. Right: digital voltmeter interface.
- Fig. 5 Interface circuit for chromatogram acquisition with a digital panel meter with BCD output.
- Fig. 6 Interface circuit for valve control with solid-state switches.
- Fig. 7 Software structure of a control time-increment, showing the interleaving of subprograms for peak-area integration, heater control and valve control.

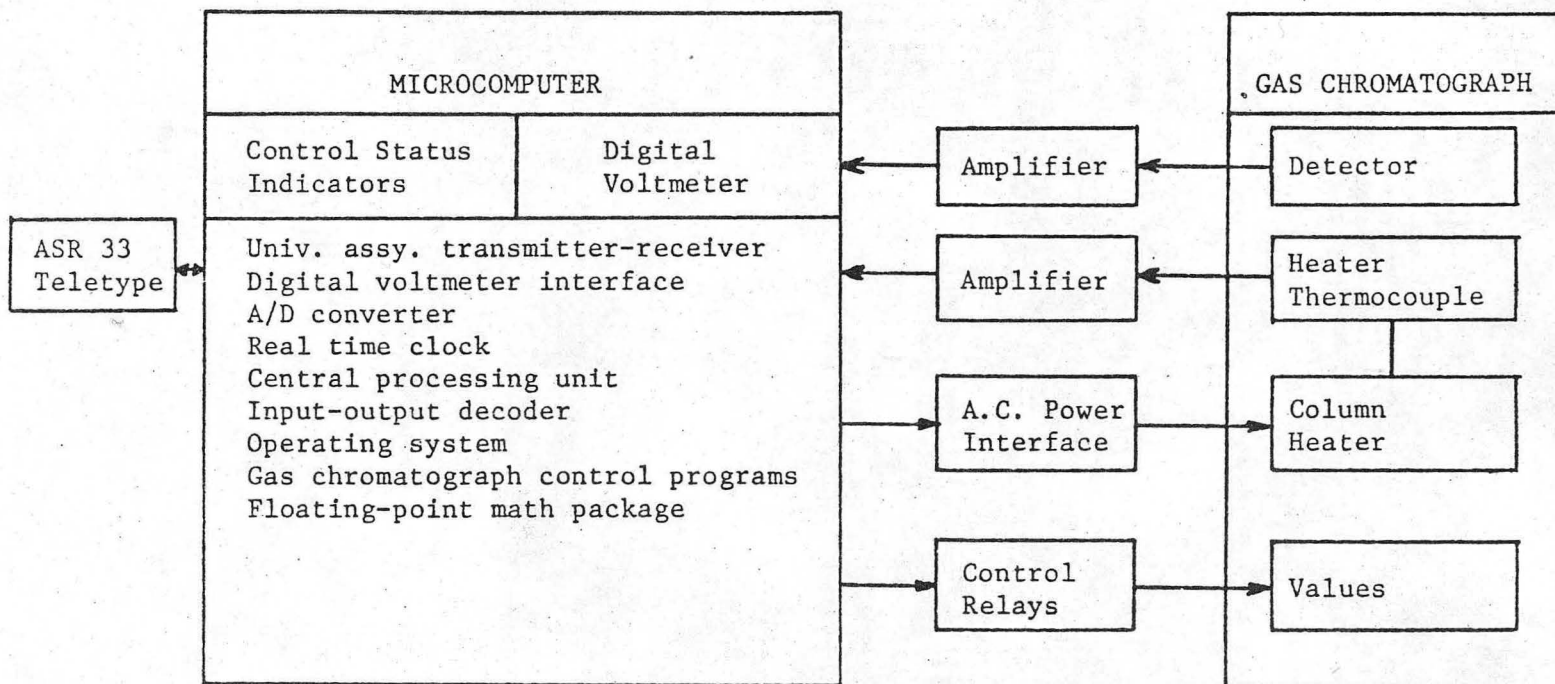

XBL 765-1733

Fig. 1 Schematic of a microcomputer system for control and on-line analysis of a gas chromatograph.

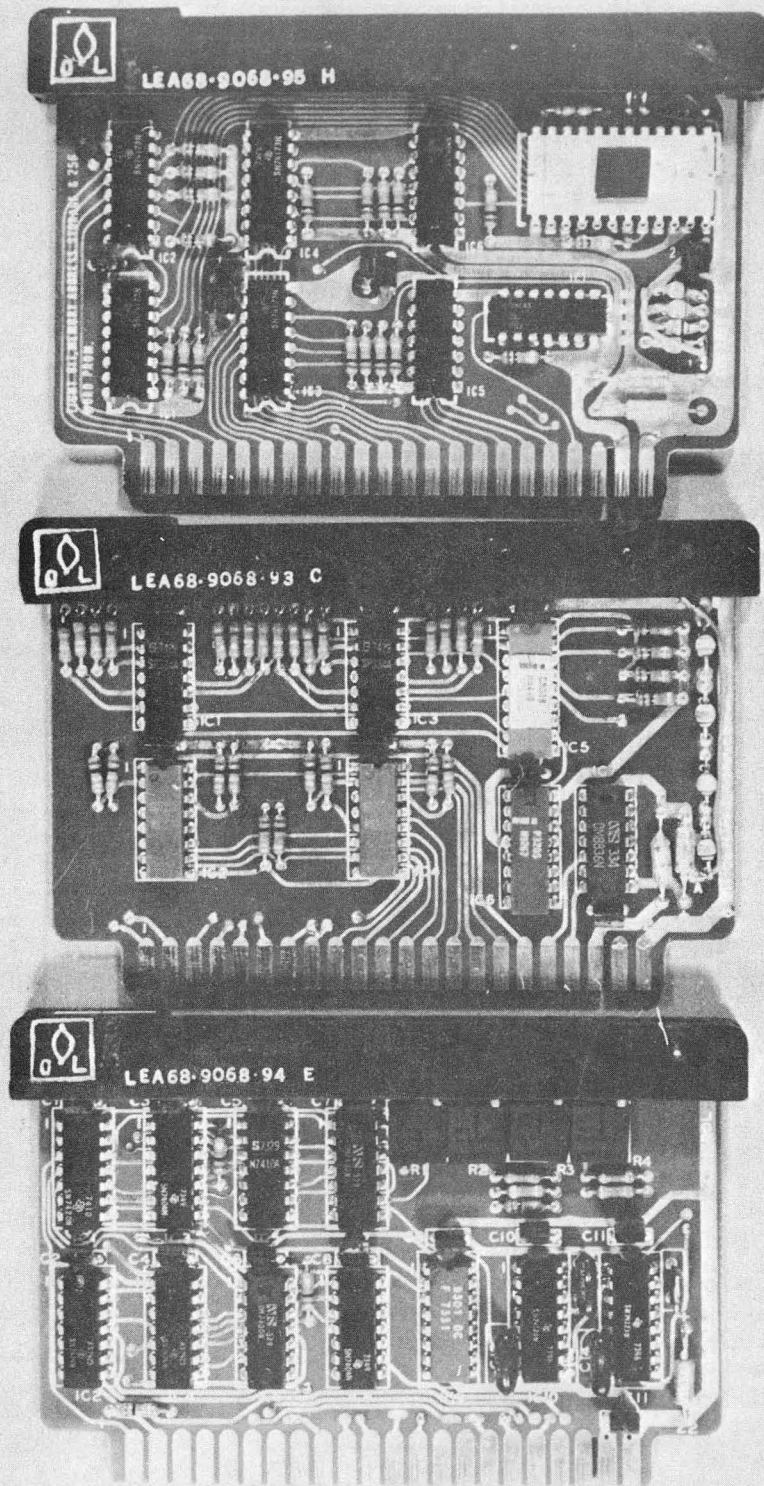
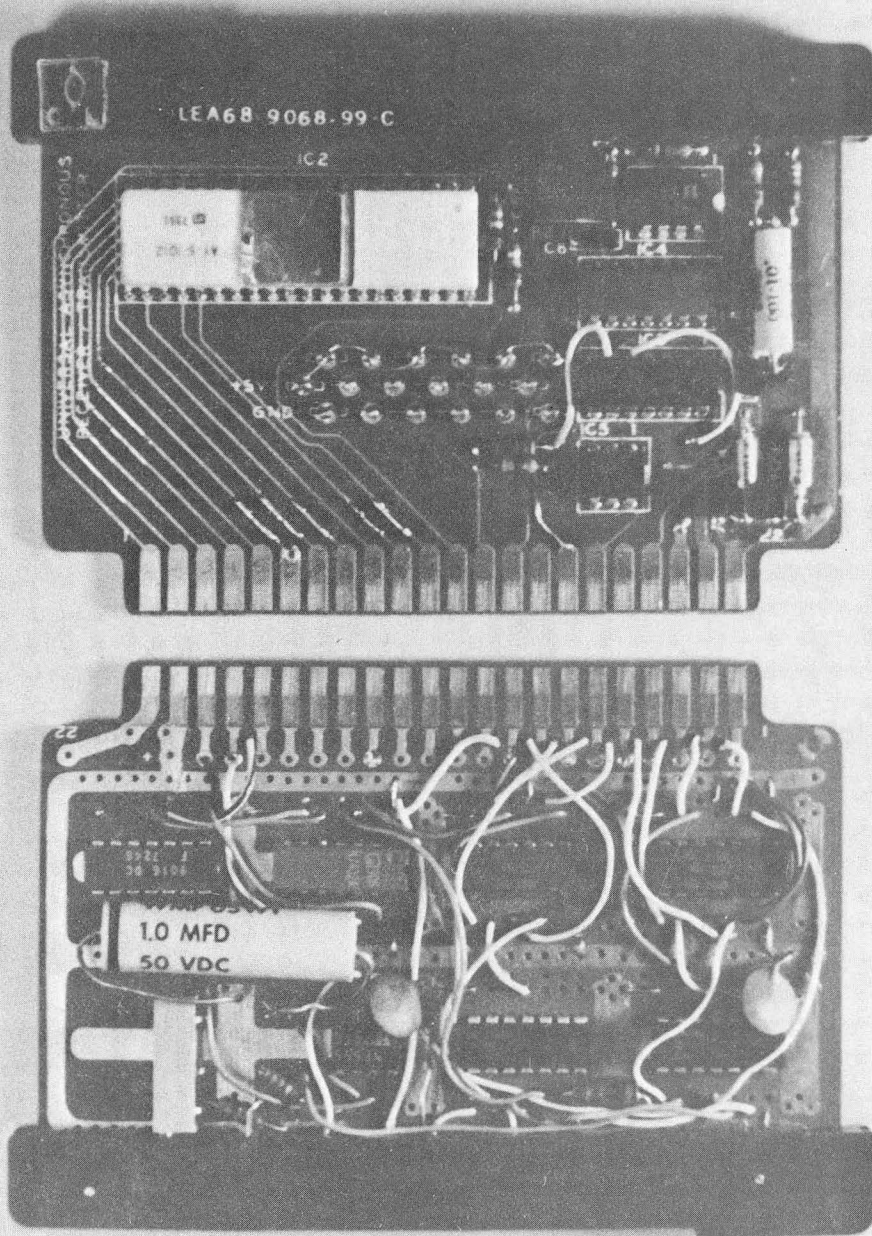

Fig. 2 Modular circuit boards for the Intel 8008-based microcomputer system. Left: input-output control module. Center: central processor module. Right: memory address-storage module with programmable read-only memory for the operating system.

XBB 757-5249



XBB 765-4284

Fig. 3 Special-function modules. Left: real-time clock module. Right: universal asynchronous transmitter-receiver.

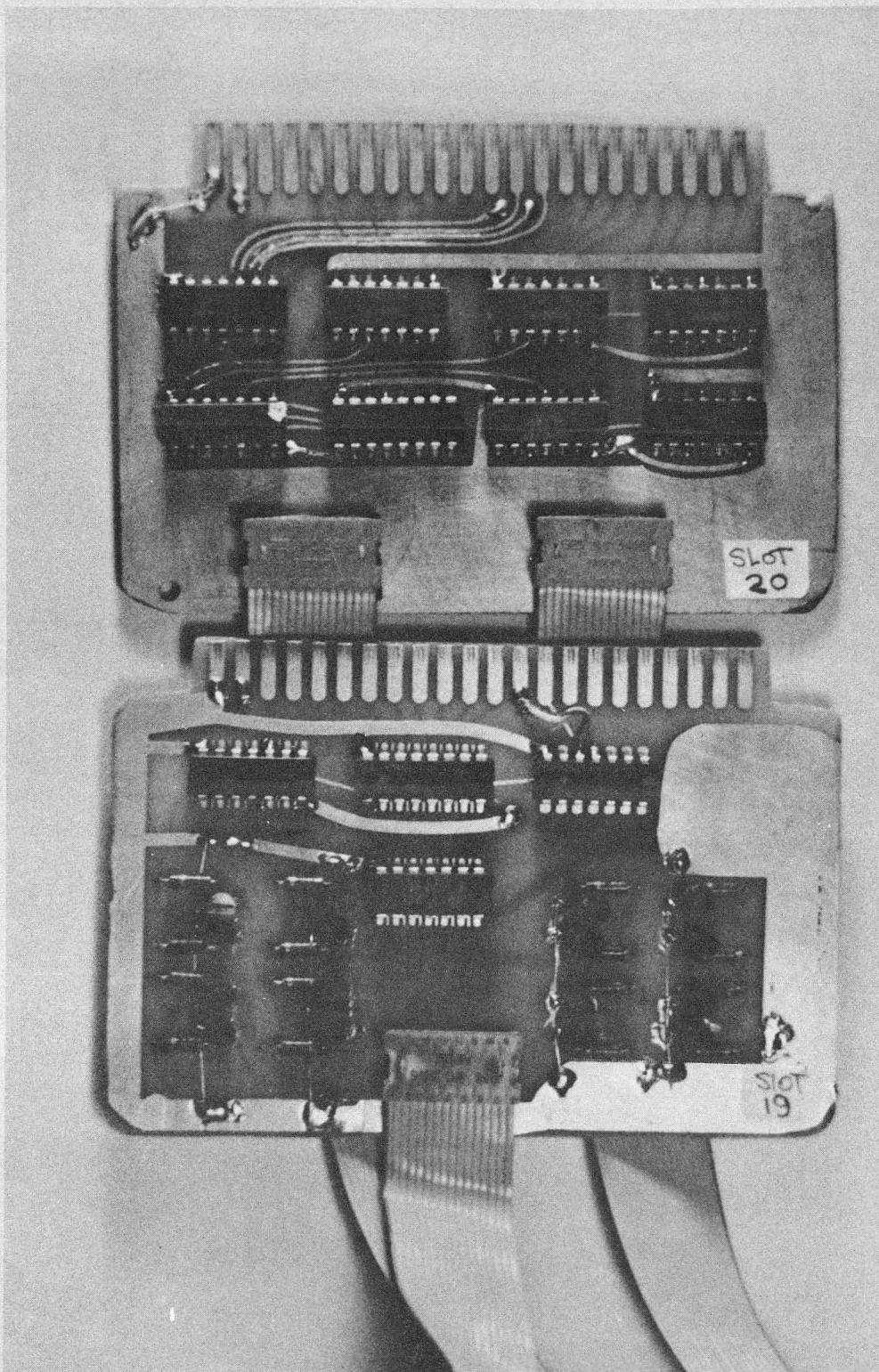

XBB 765-4283

Fig. 4 Interface modules. Left: valve-control relay interface. Right: digital voltmeter interface.

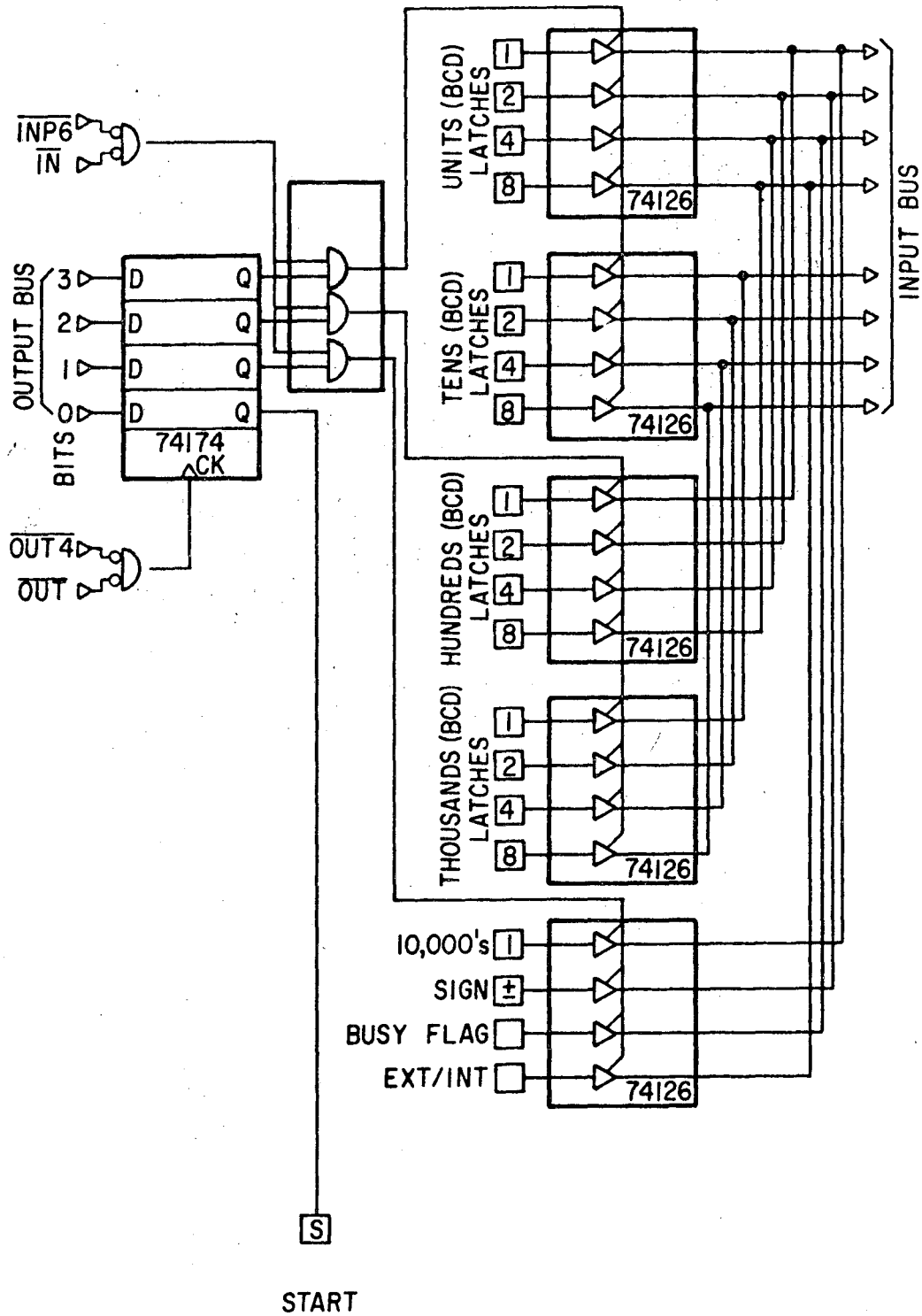

XBL 7512-9452A

Fig. 5 Interface circuit for chromatogram acquisition with a digital panel meter with BCD output.

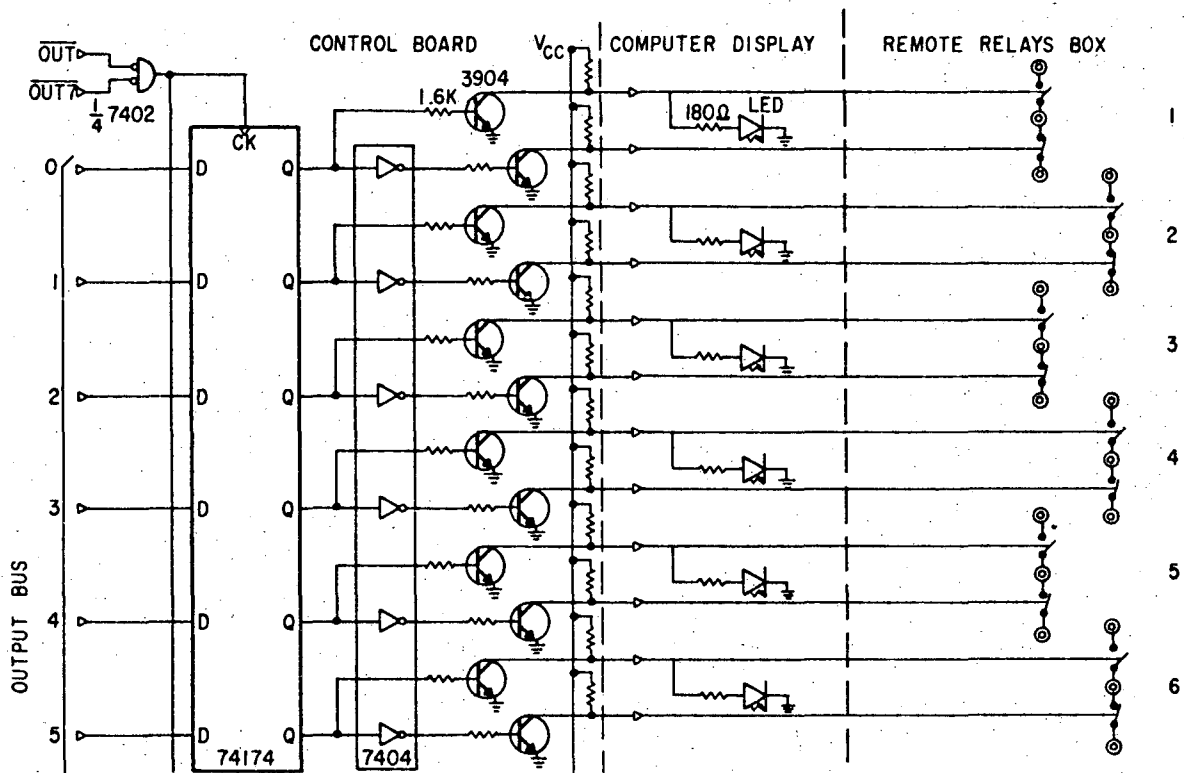

XBL 7512-9455A

Fig. 6 Interface circuit for valve control with solid-state switches.

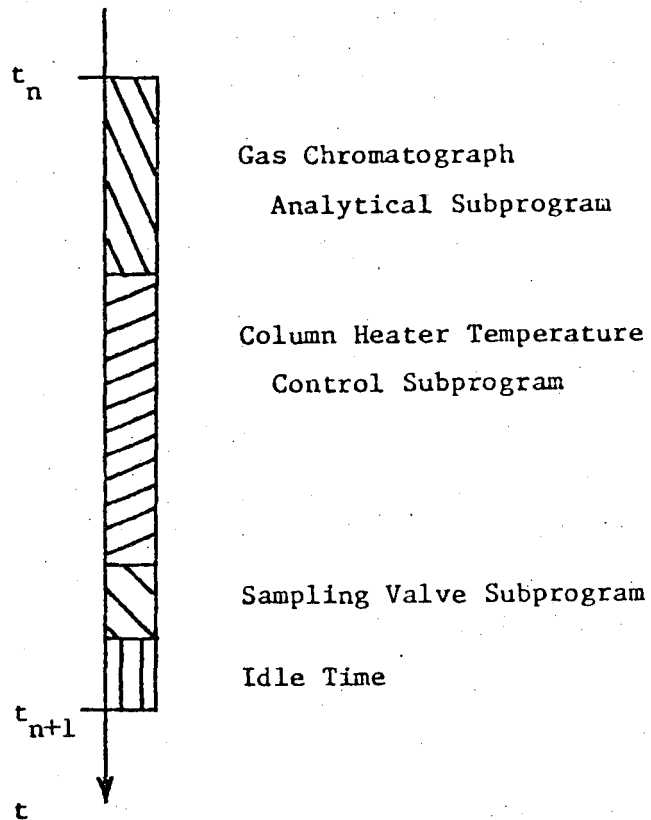

XBL 765-1734

Fig. 7 Software structure of a control time-increment, showing the interleaving of subprograms for peak-area integration, heater control and valve control.

This report was done with support from the United States Energy Research and Development Administration. Any conclusions or opinions expressed in this report represent solely those of the author(s) and not necessarily those of The Regents of the University of California, the Lawrence Berkeley Laboratory or the United States Energy Research and Development Administration.

TECHNICAL INFORMATION DIVISION
LAWRENCE BERKELEY LABORATORY
UNIVERSITY OF CALIFORNIA
BERKELEY, CALIFORNIA 94720