

Lawrence Berkeley National Laboratory

Lawrence Berkeley National Laboratory

Title

LOCOMOTIVE DATA ACQUISITION PACKAGE

Permalink

<https://escholarship.org/uc/item/9n39r4nb>

Author

Abbott, Robert K.

Publication Date

2011-04-18

00705105739

LBL-7945
UC-96

LOCOMOTIVE DATA ACQUISITION PACKAGE

PHASE 1 • FINAL REPORT

Robert K. Abbott
Frederick Kirsten
Donald R. Mullen
David B. Turner

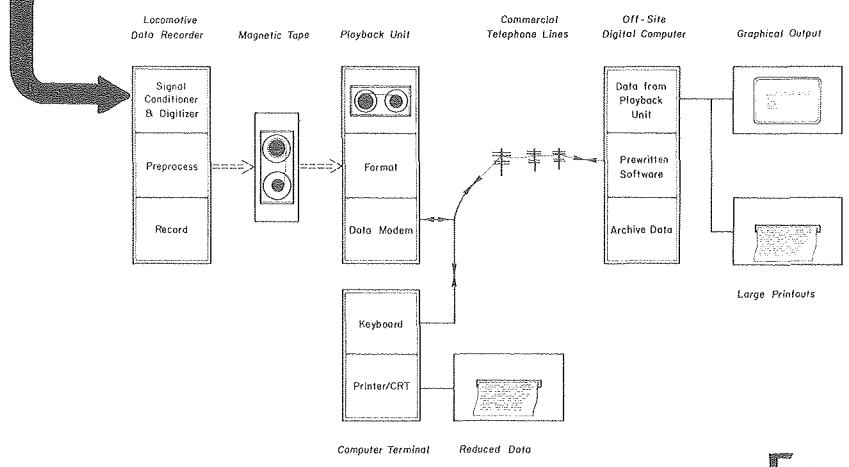
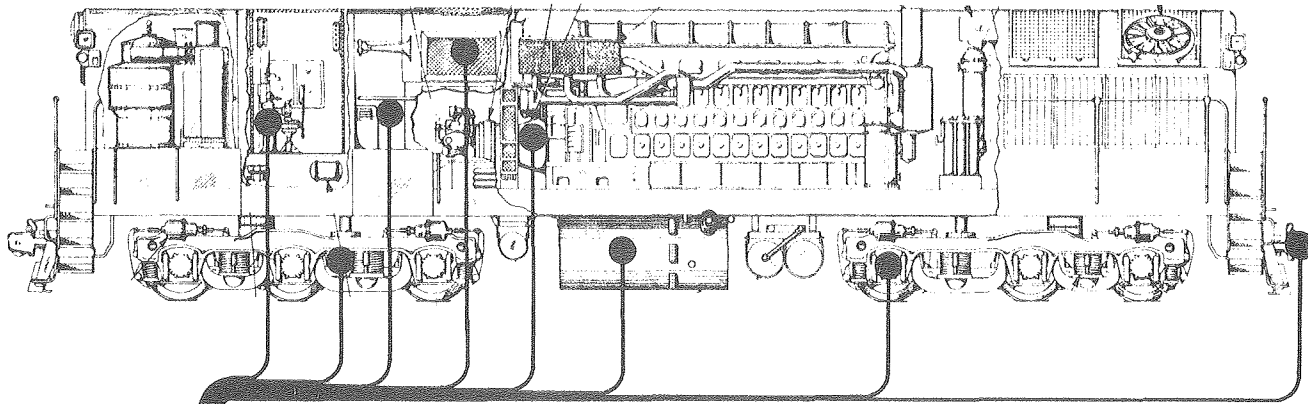

For Reference

SEPTEMBER 1978

Not to be taken from this room

LAWRENCE BERKELEY LABORATORY
UNIVERSITY OF CALIFORNIA
BERKELEY, CA

Prepared for the U. S. Department of Transportation under Interagency Agreement AR-74348 with the U. S. Department of Energy by the Lawrence Berkeley Laboratory under Contract W-7405-ENG-48.

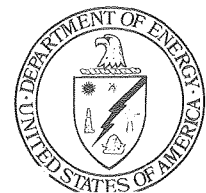

LBL-7945
01

LEGAL NOTICE

This report was prepared as an account of work sponsored by the United States Government. Neither the United States nor the Department of Energy, nor any of their employees, nor any of their contractors, subcontractors, or their employees, makes any warranty, express or implied, or assumes any legal liability or responsibility for the accuracy, completeness or usefulness of any information, apparatus, product or process disclosed, or represents that its use would not infringe privately owned rights.

Printed in the United States of America

Available from

National Technical Information Service

U. S. Department of Commerce

5285 Port Royal Road

Springfield, VA 22161

Price: Printed Copy, \$ 6.50 Domestic; \$13.00 Foreign
Microfiche, \$ 3.00 Domestic; \$ 4.50 Foreign

00403105780

1. Report No.		2. Government Accession No.		3. Recipient's Catalog No.	
4. Title and Subtitle Locomotive Data Acquisition Package				5. Report Date July 1978	
				6. Performing Organization Code	
7. Author(s) F.A. Kirsten, R.K. Abbott, D.R. Mullen, D.B. Turner				8. Performing Organization Report No. LBL-7945	
9. Performing Organization Name and Address Lawrence Berkeley Laboratory One Cyclotron Road Berkeley, California 94720				10. Work Unit No. (TRAIS)	
				11. Contract or Grant No. AR-74348	
12. Sponsoring Agency Name and Address U.S. Department of Transportation Federal Railroad Administration Office of Research and Development Washington, D.C. 20540				13. Type of Report and Period Covered Phase I Final Report October 1977 - July 1978	
				14. Sponsoring Agency Code DOT/FRA/OR&D/RRD-12	
15. Supplementary Notes					
16. Abstract A preliminary examination of the problems associated with railroad locomotive data acquisition is presented. An approach toward the design of a microprocessor-based locomotive data recorder is also presented. Special attention is placed on determining the functional characteristics and environmental specifications required for the system. The system described consists of a magnetic tape digital data recorder, an ensemble of transducers, and analysis software. The system described is to be used as a research tool.					
17. Key Words Railroad Locomotive, Microprocessor, Data Acquisition			18. Distribution Statement Document is available to the public through the National Technical Information Service, Springfield, Virginia 22161		
19. Security Classif. (of this report) Unclassified		20. Security Classif. (of this page) Unclassified		21. No. of Pages	22. Price

ACKNOWLEDGMENT

The authors would like to acknowledge the following: 1) Dr. Andrew M. Sessler, Director of Lawrence Berkeley Laboratory, and Walter D. Hartsough, Associate Director and Division Head, Engineering and Technical Services Division, for their encouragement; 2) Dr. D. Theodore Scalise, Department Head, Engineering Sciences Department, for his guidance and encouragement; 3) the Federal Railroad Administration, the Transportation Systems Center, and the Transportation Test Center, for their help and encouragement; and 4) the following railroads, for their time and insight, which helped to keep this work relevant -- Southern Pacific Transportation Company, Union Pacific Railroad, Atchison, Topeka and Santa Fe Railway Company, Burlington Northern, Illinois Central Gulf Railroad, Canadian National Railways.

PREFACE

The effort described in this report was carried out under Inter-agency Agreement AR-74348 between the U.S. Department of Energy and the U.S. Department of Transportation. It is part of a larger program to provide a technical basis for improving transportation service, efficiency and productivity. This program is sponsored by the Federal Railroad Administration, Office of Freight Systems.

During Phase I of this project, the functional requirements of the Locomotive Data Acquisition Package (LDAP) were studied. In order to verify the feasibility of designing a system to meet these requirements, a preliminary design has been formulated. In this report, details of this preliminary design are discussed. It should be borne in mind that the architecture of the prototype to be designed and built in Phase II may differ from that described in the Phase I report. However, the functional and operational characteristics will be essentially similar.



LOCOMOTIVE DATA ACQUISITION PACKAGE

PHASE I - FINAL REPORT

Definition of Functional Requirements

Table of Contents

1. Introduction 1

1.1 Purpose of this Report 1

1.2 An Overview of the Locomotive Performance Analysis (LPA) Program 2

1.3 Locomotive Data Acquisition Package (LDAP) System Elements 4

1.4 Factors Influencing LDAP Project 6

1.5 The LDAP Project Plan 6

2. Measuring Capability Requirements 11

2.1 Need for an LDAP 11

2.2 Typical Locomotive Testing Programs 12

2.3 Locomotive Parameters to be Measured 15

3. Locomotive Data Recorder Design Concepts 19

3.1 Introduction 19

3.2 Physical Characteristics of the Locomotive Data Recorder (LDR) 19

3.3 LDR Functions 23

3.4 LDR Sensor Interface 25

3.5 The Digital Cartridge Recorder 29

3.6 Control and Data Memory 30

4. Packaging for the Locomotive Shock and Vibration Environment . . 33

4.1 Introduction 33

4.2 Input Shock and Vibration Specifications 33

4.3 Equipment Fragility; the Need for Isolation 41

4.4 Isolation - A Center of Gravity Approach 43

4.5 Shock and Vibration - General Hardware Considerations . . . 47

4.6 Shock and Vibration Isolation - Specific Hardware Considerations 53

4.7 Shock and Vibration Tests 63

5.	Transducers	69
5.1	Availability of Transducers	69
5.2	General Comments on Transducers	70
5.3	Transducers, Buff-Draft Forces	72
5.4	Instrument Transducers for LDAP - Fuel Flow	82
6.	Data Processing Considerations	95
6.1	Introduction	95
6.2	Information Flow and Processing Functions	95
6.3	Sources of Data	96
6.4	Recording Algorithms and Formats	99
6.5	Analysis Functions and Computer Programs	101
6.6	Predetermined/Interactive Programming	105
7.	References	107
	Appendix A: LDAP Functional Specification	109

FIGURES

1.	Block Diagram of the Major System Elements of the Locomotive Data Acquisition Package (LDAP).	5
2.	Preliminary Design for Physical Packaging of the Locomotive Data Recorder (LDR).	20
3.	Conceptual Design of a Front Panel for the LDR. Operator Controls and Indicators Are Shown.	22
4.	Block Diagram of the Digital Bus Structure of LDR	24
5.	LDR Sensor Interface: a) LDR Sensor Connection, and b) Multiplexer and Analog-to-Digital Converter.	27
6.	Source Vibration Specification for LDAP: X, Y, and Z Directions.	38
7.	Shock Specification for LDAP: X, Y, and Z Directions	40
8.	Source and Fragility Envelopes.	42
9.	Basic Isolation System.	44
10.	Suspended LDAP Unit on Four Isolators	46
11.	Transfer Ratio Related to Frequency	49
12.	Ideal Transmissibility for a Single Degree of Freedom, Viscously Damped, Linear System.	51
13.	Viscous-Damped, All-Attitude Vibration Isolator	56
14.	U-Type Leaf Spring Isolator	57
15.	Friction and Air-Damped Vibration Isolators	58
16.	"Box-Inside-A-Box" Case Design.	59
17.	Example of Mil-Std-21200 Enclosure.	61
18.	Fragility Surfaces.	64
19.	Random Vibration Test Envelope.	66
20.	Four Basic Coupler Loading Modes.	76
21.	Locomotive Coupler Shank Strain	78

22.	Force Transducer Scheme	83
23.	Two Classes of Flowmeters for Use for Locomotive Fuel Flow Measurements	86
24.	Two Methods for Obtaining Mass Flow Rate.	89
25.	Vertical Vibration Tests of the Four-Piston Flowmeter	93
26.	Vertical and Horizontal Vibration Tests of the Four-Piston Flowmeter.	94
27.	Information Flow and Processing Functions of the LDAP	97

TABLES

1. LDAP Project Plan	7
2. Locomotive Parameters Expected to Be Measured	16
3. Magnitudes and Spectrum of the Vibration Specifications Listed for LDAP	37
4. Measurands Requiring Special Transducers to Be Added to Existing Locomotive Equipment	70
5. Transducing Possibilities That Are Applicable to LDAP	73
6. Data/Information Sources	98
7. Some Sampling and Recording Algorithms (Sequences) That May Be Employed in the LDAP System	100
8. Types of Processing to be Performed by Computer Programs . . .	102

1. INTRODUCTION

In response to requests from the railroad industry, the Federal Railroad Administration has initiated a multiphased Locomotive Performance Analysis (LPA) program to explore ways of reducing the life-cycle costs associated with owning and operating a diesel-electric freight locomotive. This program is comprised of three elements:

1. Developing a locomotive reliability and maintenance data base from repair shop records;
2. Characterizing locomotive equipment operations over a wide range of service conditions;
3. Formulating a comprehensive research plan to enhance locomotive efficiency, reliability, utilization and safety.

In September 1977, the Federal Railroad Administration contracted with the Lawrence Berkeley Laboratory (LBL) for the development of a Locomotive Data Acquisition Package (LDAP) to support the LPA Program. The package will include 1) a self-contained data recorder, 2) an ensemble of sensors and transducers for measuring locomotive performance parameters, and 3) computer programs for data analysis. This report covers the preliminary phase of the project to develop a fully operational Locomotive Data Acquisition Package.

1.1 PURPOSE OF THIS REPORT

The purpose of this report is to discuss the designs and concepts developed in Phase I -- Definition of Functional Requirements. The intent is to provide sufficient information so that prospective users of the system can understand the general design concepts, the nature and purpose of the total system that is being developed and,

to a limited extent, how it can be applied to locomotive research problems. Technical implementation details are limited to those necessary to properly understand the functions of the system components. Sections 1 and 2 discuss functional characteristics of the system, system constraints and the overall approach. Section 3 discusses the electronic structure for the system. Since the locomotive environment is known to be harsh to electronic equipment, it is important that the LDAP be sufficiently rugged to withstand the shocks and vibrations that are typically present on an operating locomotive. This aspect is discussed in detail in Section 4. The subject of transducers is covered in Section 5, and some aspects of the analysis of measurement data are in Section 6.

1.2 AN OVERVIEW OF THE LOCOMOTIVE PERFORMANCE ANALYSIS (LPA) PROGRAM

It is not difficult to substantiate the need for the LPA program. A large U.S. railroad may have a locomotive fleet with a present value of approximately \$300 million. It may face annual bills for locomotive maintenance of approximately \$100 million.¹ Fuel costs alone often approach or exceed \$100 million.¹ This clearly indicates the magnitude of the potential economic impact of fleet-wide decisions affecting operations, maintenance or equipment modifications, and substantiates the need for a statistically valid base of operating data for making those decisions.

Recent studies have estimated the cost of maintaining a line-haul diesel-electric locomotive to be only slightly less than \$100,000 a year, exclusive of fuel and predispatch servicing.¹ The LPA program

is based on the expectation that it may be possible to reduce this cost by formulating more complete maintenance procedures, by developing better methods of scheduling preventative maintenance, by developing more accurate methods of diagnosing problems, by suggesting product improvements, or by modifying train handling procedures to minimize wear and tear on the locomotives. At this early point in the program the potential cost savings of any of these techniques is uncertain. It is clear, however, that substantial commitments of resources are required to fully develop these techniques. It is also clear that a successful program must be based on properly analyzing actual operating data that have been acquired from a wide spectrum of operating conditions. Actual railroad operating conditions vary between the extremes of desert heat to arctic cold; between slow speed trains with power-to-weight ratios of 1 hp/ton to "hot shot" trains with ratios of 6-7 hp/ton; between steeply ascending, to level, to steeply descending grades; between speed limits of 20 mph to 70 mph, etc. The Locomotive Performance Analysis program was formulated to provide the means to obtain the volume of engineering data necessary to attack the problem.

A primary objective of the LPA program is the identification of the locomotive subsystems that are appropriate to include in future reliability improvement research and development programs. A second objective is the acquisition of locomotive equipment data that can be used to improve design specifications during a later product improvement effort. It is hoped that the availability of a complete and accurate data base will serve to stimulate research and development in the private sector as well as in the government. In this

context, the present LPA effort can be considered to represent the problem definition phase of a longer range program.

A third objective of the LPA program concerns the subject of this report, i.e., the development and use of several Locomotive Data Acquisition Packages. At present, research quality instrumentation packages suitable for direct attachment to a locomotive do not exist. The research and test departments of individual railroad companies and the American Association of Railroads have indicated the need for such a package. They have also indicated an interest in purchasing a small number of packages, if developmental costs could be borne by others. Therefore, the design philosophy for LDAP has recognized the need for the package to be useful and available to individual railroads and others to use in dedicated research efforts.

1.3 LOCOMOTIVE DATA ACQUISITION PACKAGE (LDAP) SYSTEM ELEMENTS

The LDAP instrumentation system is comprised of the following elements, as shown in Figure 1:

- a. A network of transducers that have been selected or designed to provide sufficiently accurate measurements of the physical phenomena under test.
- b. A rugged, portable, on-board locomotive data recorder suitable for direct attachment to a locomotive and capable of recording a wide spectrum of transducer-generated electrical signals on magnetic tape.
- c. A playback unit that will convert the tape recorded data into a format compatible with a digital computer.
- d. A data modem for transmission of locomotive-recorded data to a computer facility.
- e. The use of a medium- or large-scale digital computer for data reduction, analysis, report preparation, and long-term storage of data files.

- f. A library of computer programs for data analysis and report preparation.

1.4 FACTORS INFLUENCING THE LDAP PROJECT

The LDAP project plan was influenced by the following factors:

- a. The attainment of a high level of LDAP equipment reliability, in an extremely harsh railroad operating environment, is likely to be the most difficult and the most important design objective.
- b. Complete documentation that accurately characterizes the railroad operating environment simply does not exist. A complete characterization would include shock and vibration power spectral densities; electromagnetic interference power spectral densities; and the frequency, duration and repetition rates of voltage transients on power supplies.
- c. Complete descriptions of all tests that LDAP will be required to perform during its lifetime are not available. Therefore, care must be taken to provide capability to expand or modify the facilities of the package to cope with future requirements.
- d. The exact number of recorder units to be constructed eventually has not yet been determined. To date three major U.S. railroads have shown interest in the project and have indicated a potential interest in purchasing some finished units. The Federal Railroad Administration (FRA) desires to support that interest and anticipates the direct purchase and use of recorders by private companies.
- e. A research engineer's time is most productively spent designing tests and analyzing the results. LDAP will therefore be designed to permit the engineer to minimize the time spent in modifying, operating, or repairing the equipment.
- f. Many of the building blocks needed in LDAP are already commercially available, well supported, and documented. This includes items such as microprocessor single-board computers, data terminals, data modems, memory buffers, and digitizers. During the design process, efforts will be made to avoid custom designs where such commercial modules can meet the operating and environmental requirements.

1.5 THE LDAP PROJECT PLAN

The LDAP project is comprised of three phases: (I) Definition of Functional Requirements, (II) Pre-Prototype Construction, and

(III) Private Manufacturing. The tasks under each phase are listed in Table 1.

Table 1. LDAP PROJECT PLAN

Phase I -- Definition of Functional Requirments/Preliminary Design
(Fall 1977 - Winter 1977)

- Define Functional Needs
- Determine Project Approach
- Develop Design Specifications

Phase II -- Pre-Prototype Construction (Spring 1978 - Winter 1978)

- Design Prototype Locomotive Data Recorder (LDR)
- Fabricate, Test and Operate One LDR Unit
- Gather Data on Operating Environment in a Locomotive
- Value Engineer for Subsequent Manufacture
- Document Final Configuraton
- Select and Procure Sensors
- Design, Write and Document Software
- Assemble and Test a Complete System

Phase III - Private Manufacturing (Spring 1979 - Fall 1979)

- A private electronics manufacturing company will manufacture a small number of recorders from prototype drawings, for FRA deployment.
-

Phase I (Definition of Functional Requirements/Preliminary Design). This phase was started in the fall of 1977, completed in April of 1978, and is the subject of this report. During this phase the project approach was defined, the functional requirements determined, and a performance specification developed.

Phase II (Pre-Prototype Construction). Initiated in May 1978, this phase will be completed during the spring of 1979. Phase I investigations made it clear that definitive data on the harshness of the locomotive environment do not exist. Estimates of worst-case shock, vibration, transient voltages and electromagnetic effects varied,

in some cases, by a factor of ten, depending upon the source. In addition, both the literature and personal communications with railroad officials revealed that many previous attempts to adapt new data acquisition and measurement technology to the railroad environment had failed because of poor reliability. We believe that those attempts resulted in low reliability because the equipment designers did not fully understand the environment in which the equipment would be used. On the basis of these facts, we decided to construct the prototype LDR unit to withstand the most severe environment possible. It is expected that the data obtained during the first few tests will focus on the locomotive environment and that this will lead to the development of a less severe set of environmental specifications for subsequent commercial manufacture of LDR units.

During Phase II, the data recorder and the playback unit will be developed, fabricated, and tested by LBL. The off-site digital computer will not be provided as part of the package. Instead, the system will be designed to accept as wide a range of computer installations as practical. Initial testing will be performed using the CDC 7600 computer system at LBL, which can be accessed from remote locations by phone lines. The computer terminal is a commercial item that will be purchased. The software routines necessary for proving the operation of the total LDAP system and for carrying out a preliminary measurement task will be designed and written. Complete documentation for the use of the software will be prepared.

0 0 0 0 5 1 0 0 7 7 0

Phase III (Private Manufacturing). Phase III involves the manufacturing of a small number of LDAPs for FRA and provides for their purchase from the manufacturer by others desiring them. The manufacture will be done by a private electronics fabrication company yet to be selected by FRA. They will manufacture the instrument in accordance with LBL drawings developed under Phase II.

2. MEASURING CAPABILITY REQUIREMENTS

2.1 NEED FOR AN LDAP

At the present time there are three basic methods of data acquisition available to those interested in monitoring locomotive operation.

They are:

a. Dynamometer/Instrumentation Cars.

Most often these are passenger cars that have been converted to provide a livable environment for computer automated electronic instrumentation and the accompanying test technicians. Crew size usually varies between 3 to 8 people. Of the 70 Class I railroads in the United States, only about 5 to 10 own such cars; the total number of instrumentation cars in the U.S. is of the order of 15 to 20. These cars are generally instrumented to perform large-scale tests on complicated engineering questions, and toward that end have proven valuable. Principal limitations have been the fairly large effort required to support these cars prior to, during and after a test, and the small number of cars available for use.

b. Speed-Tape Recorders.

A small number of railroad suppliers presently market speed-tape records that can be attached to their locomotive speedometers. These devices generally use paper tape as the recording medium, although two magnetic tape units are also available. They are designed to be used to verify engineman compliance with speed limits and usually record either speed alone or speed together with two or three digital signals. Not generally used for research purposes, these recorders are extremely limited in data capacity and number of channels. Furthermore, data reduction can be extremely laborious.

c. A Research Engineer, a Meter, and a Clipboard.

This technique is self-explanatory and is used occasionally. Its main shortcomings are that: 1) data gathering is difficult, tedious, and time consuming; 2) tests involving data acquisition at adequately high sampling rates are impractical; and 3) this technique is prone to recording errors.

A common characteristic of all three techniques is the difficulty in obtaining statistically valid data under a full range of operating conditions. It is this need for a technique for gathering statistically valid data that LDAP seeks to fill.

The LDAP instrumentation system has been planned to augment the three existing choices mentioned above. It will represent a level of capability greater than existing speed tape recorders, but less than conventional dynamometer cars. The recorder portion of the system is being designed to be rugged, portable, and programmable. It will have a capacity of monitoring up to 48 transducers or sensors, although only about 20 channels would be needed for a typical application. The capacity of the tape cartridge in terms of operating hours is determined by the total number of samples taken. The unit may be programmed for a tape capacity of as much as two weeks of operation if the number of channels and sample rates are held to a minimum. Typical recording capacities are expected to be on the order of 48-72 hours.

The LDAP instrumentation system will be designed to be compatible with the operational constraints of the railroad. It is recognized that railroads are operating properties, not research organizations. The proportion of railroad personnel familiar with current electronic technology is probably much less than one percent of the work force. Research and test activities are usually constrained to minimize any adverse impact on transportation operations.

2.2 TYPICAL LOCOMOTIVE TESTING PROGRAMS

The scopes and details of all of the tests that will be performed are not usually known at the beginning of most experimental programs. However, it is important to develop test equipment that is both flexible and adaptable, and to anticipate functional requirements. To do that, one must anticipate the general nature of the tests for which LDAP

will be used. From discussions held with railroad test engineers, railroad engineering managers and government officials, a list of potential tests was developed. This list as detailed below is not intended to be complete, but rather to serve as a guide to the spectrum of tests for which LDAP may be employed. The list is as follows:

1. Consist terminal-to-terminal run time and schedule compliance as a function of hp/ton ratios and train handling procedures.
2. Freight ride quality as a function of track location and train handling procedures.
3. Buff/Draft and Lateral/Vertical force ratios as a function of train handling, train make-up, and/or track location.
4. Characterization of the locomotive environment (parameters such as shock, vibration, noise, etc.).
5. Characterization of locomotive component equipment operation.
6. Locomotive voltage transients, their causes, magnitudes, frequencies, and the effects of attempts to reduce them.
7. Slip/slide circuitry efficiencies and performance.
8. Causes of intermittent alarms such as ground fault, hot engine, etc.
9. Causes of traction motor flashover.
10. Locomotive fuel economy as a function of locomotive equipment.
11. Locomotive fuel economy as a function of train handling.

In terms of specific requirements, tests 1 and 6 are likely to require sample rates on the order of one sample per second for most of the parameters of interest. Accuracies of approximately $\pm 5\%$ will probably be adequate for most parameters. The minimum required time between tape changes is likely to be on the order of 2-3 days.

Tests 2, 3, 4 and 5, while similar to tests 1 and 6, are likely

to impose the additional requirement that some parameters must be monitored at sample rates higher than one sample per second. At maximum RPM, the diesel engine on an EMD SD-40 locomotive has a firing frequency of 240 Hz, the main traction alternator frequency is 75 Hz and the companion alternator frequency is 120 Hz. At 60 mph, the traction motor commutator frequency is approximately 400 Hz. Electromechanical contactor pickup and drop times are assumed to be no faster than 10 milliseconds. These fundamental frequencies of locomotive components will determine the required LDAP sample rates.

Tests 7, 8 and 9, while similar to tests 2, 3, 4 and 5 in most aspects, will benefit from a capability to automatically increase the sampling rates to cover the period just before and just after the alarm with increased resolution. (Recording histories just before an alarm can be accomplished with internal memory.)

Tests 10 and 11 impose requirements similar to tests 1 and 6 except that higher measurement accuracies will be required. In most nonfuel economy-related tests uncertainties of $\pm 5\%$ are not significant. However, the benefits of alternative procedures or equipment on fuel economy are not expected to be much greater than 5%. Thus if realistic judgments are to be made, a fuel economy measurement accuracy of 1-2% is required.

In summation, the following points (or assumptions) seem relevant:

- a. All tests will require the monitoring and recording of a small number of train descriptions -- items such as throttle position, train speed, train location, etc.
- b. The recorder (LDR) must be designed to "stand-alone" and not require on-board technical personnel for most tests.
- c. For most tests, accuracies of $\pm 5\%$ are sufficient. However, for fuel economy experiments, parameters such as fuel

flow, prime mover RPM, and fuel temperature must each be known to $\pm 1\%$ or better.

- d. Some tests will require sample rates as low as one sample per second, others higher than 240 per second.
- e. Some tests will require the capability to sample some parameters at a slow rate and other parameters at a different (higher) rate.
- f. Some tests will require the capability to change sample rates during a test as a result of some special event.
- g. Some tests will require the capability to look back in time, that is, to record certain information only if a specified event occurs subsequently.
- h. Some tests will require the system (LDAP) to compare its results with other data sources such as previously recorded test data or track maps.

Each of these points will be discussed in greater detail in subsequent sections.

2.3 LOCOMOTIVE PARAMETERS TO BE MEASURED

As a result of a study of the requirements cited above, it has been concluded that LDAP should accommodate up to 48 channels. It has also been concluded that 16 of these channels should be dedicated to a basic set of parameters that appear to be fundamental to a majority of contemplated testing programs. These 16 parameters are listed in Table 2, which also lists the sampling rate expected to be used for each.

In addition, to accommodate the special requirements of individual tests, 34 other channels are planned. These are also listed in Table 2. Specific assignments for the use of these channels can be made when programming LDR for the specific test. As described within, it is also planned that the sampling rates for these can be chosen either when programming the LDR, or by instructions entered by the operator.

Table 2. LOCOMOTIVE PARAMETERS EXPECTED TO BE MEASURED

Part A: The Basic 16 Parameters

<u>Number</u>	<u>Measurand</u>	<u>Sample Rate*</u>
A01.	Speed	1 second
A02.	Independent Brake Pressure	change
A03.	Trainline Brake Pressure	change
A04.	Buff/Draft Forces	1 second
A05.	Traction Alternator Voltage	10 seconds
A06.	Traction Alternator Current	10 seconds
A07.	Dynamic Brake Current	1 second (when used)
A08.	Grade	1 second
A09.	Throttle Setting	change
A10.	Reverser Setting	change
A11.	Slip/Spin Event	occurrence
A12.	Fuel Flow In	1 second
A13.	Fuel Flow Out	1 second
A14.	Air Temperature	100 seconds
A15.	Turbo Charger Pressure	100 seconds
A16.	Engine Temperature	100 seconds

*These rates are programmable and changeable by modifying the firmware.

Table 2, cont'd.Part B: The Optional Measurement Capabilities

<u>Number</u>	<u>Measurand</u>	<u>Sample Rate</u>
A17-A20	4 pressure transducers	programmable
A21-A24	4 temperature transducers	programmable
A25-A28	4 accelerometers	programmable
A29-A32	4 analog voltages $\pm 10V$	programmable
A33-A38	6 digital event channels	programmable
A39-A50	12 spare channels	programmable

3. LOCOMOTIVE DATA RECORDER DESIGN CONCEPTS

3.1 INTRODUCTION

The Locomotive Data Recorder (LDR) of the Locomotive Data Acquisition Package (LDAP) is the collection of sensor interfaces, control electronics, and data storage which monitors and records locomotive performance parameters of interest. It should be designed and packaged to withstand a broad range of conditions including the temperature, humidity, dust, smoke, shock, vibration, and handling extremes of the diesel-electric locomotive environment. Its selection of monitored and recorded parameters should be expandable and programmable by a built-in keyboard. The selected parameters should be recorded on a digital data tape cartridge that could hold up to 1,000,000 data samples.

To verify the feasibility of designing an LDR to meet these requirements, a preliminary design has been formulated. In this section, details of this preliminary design are discussed. It should be borne in mind that the architecture of the pre-prototype to be designed and built in Phase II may differ from that described. However, the functional and operational characteristics will be essentially similar.

3.2 PHYSICAL CHARACTERISTICS OF THE LOCOMOTIVE DATA RECORDER (LDR)

Figure 2 is a sketch of a conceptual design of the physical packaging of the LDR. Visible from the top are the four main electronic components of the LDR: the power supply, the digital magnetic tape, cartridge recorder, the keyboard/display, and the control electronics. Visible on the side is the connector panel, where connections to the

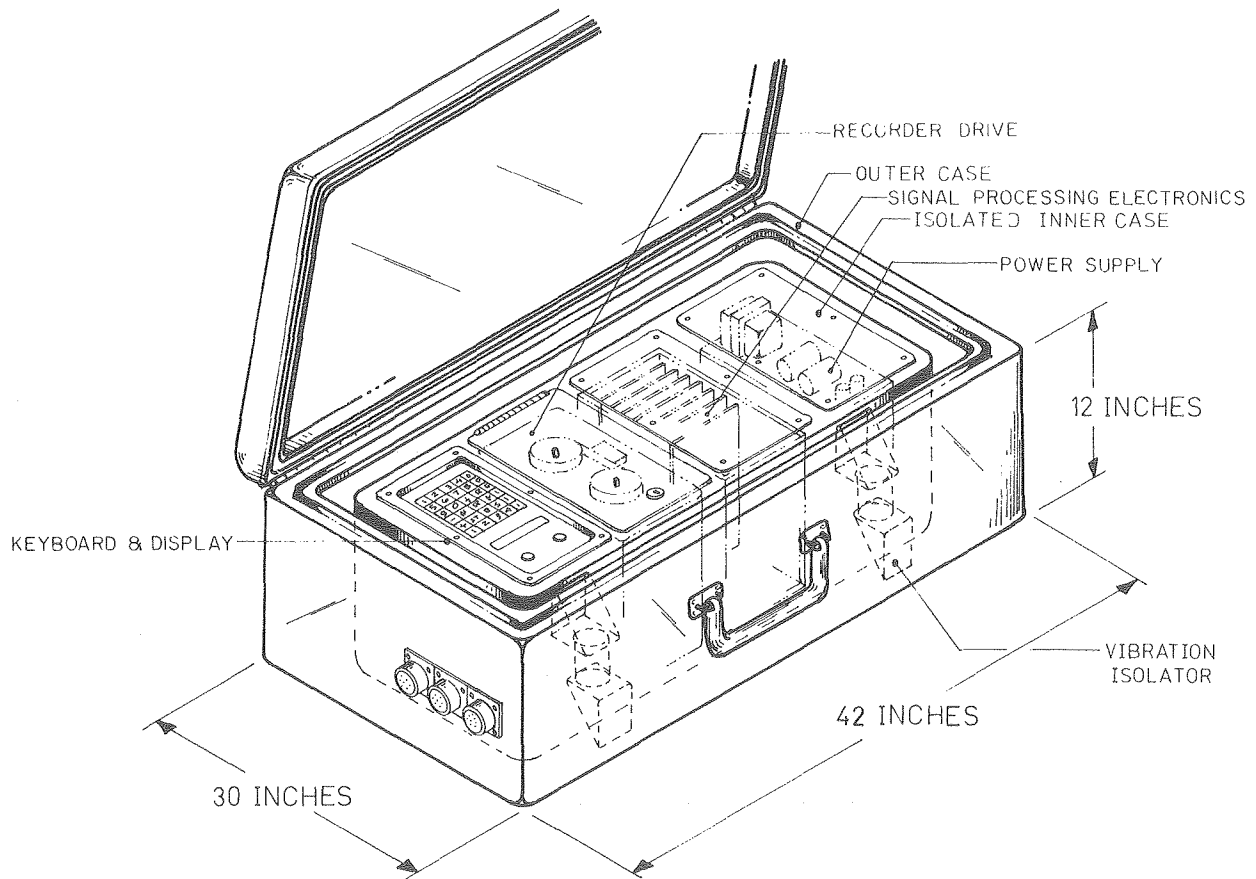

XBL 789-2236

Figure 2. Preliminary Design for Physical Packaging of the Locomotive Data Recorder (LDR).

power source and the sensors are made. In addition, one connector interfaces a remote hand-held keyboard which can be used to enter milepost or event-related information. In normal operation the cover protects the electronics, keyboard and recorder from dust and physical damage. The shock and vibration absorbing aspects of the LDR package are covered in Section 4.

This instrument is designed to be used by operators from various backgrounds. For this reason special care will be taken in the design of the operator interface -- defined as that collection of knobs and switches by which an operator communicates with or controls the instrument. In its basic mode of operation the instrument need only be started, and will then run unattended until the termination of the run. It will also have the facility to allow operator interaction for those types of tests where interaction is needed. Such interaction can be of several types:

- a. Minor modification of measuring sequence;
- b. Entering sensor calibration data;
- c. Monitoring the measured data;
- d. Entering "event" information, such as mileposts, etc.

Figure 3 is a view of one possible design for the LDR front panel. The front panel includes most of the controls by which LDR is tested and operated, and by which minor program modifications can be made. The controls include the Master Power Circuit Breaker, the Mode Enable Key switch, the Mode Select switch, the Control Keys, the Data Keyboard, the Indicator LEDs, and the Display. The uses of these controls are further described below.

LOCOMOTIVE DATA RECORDER FRONT PANEL

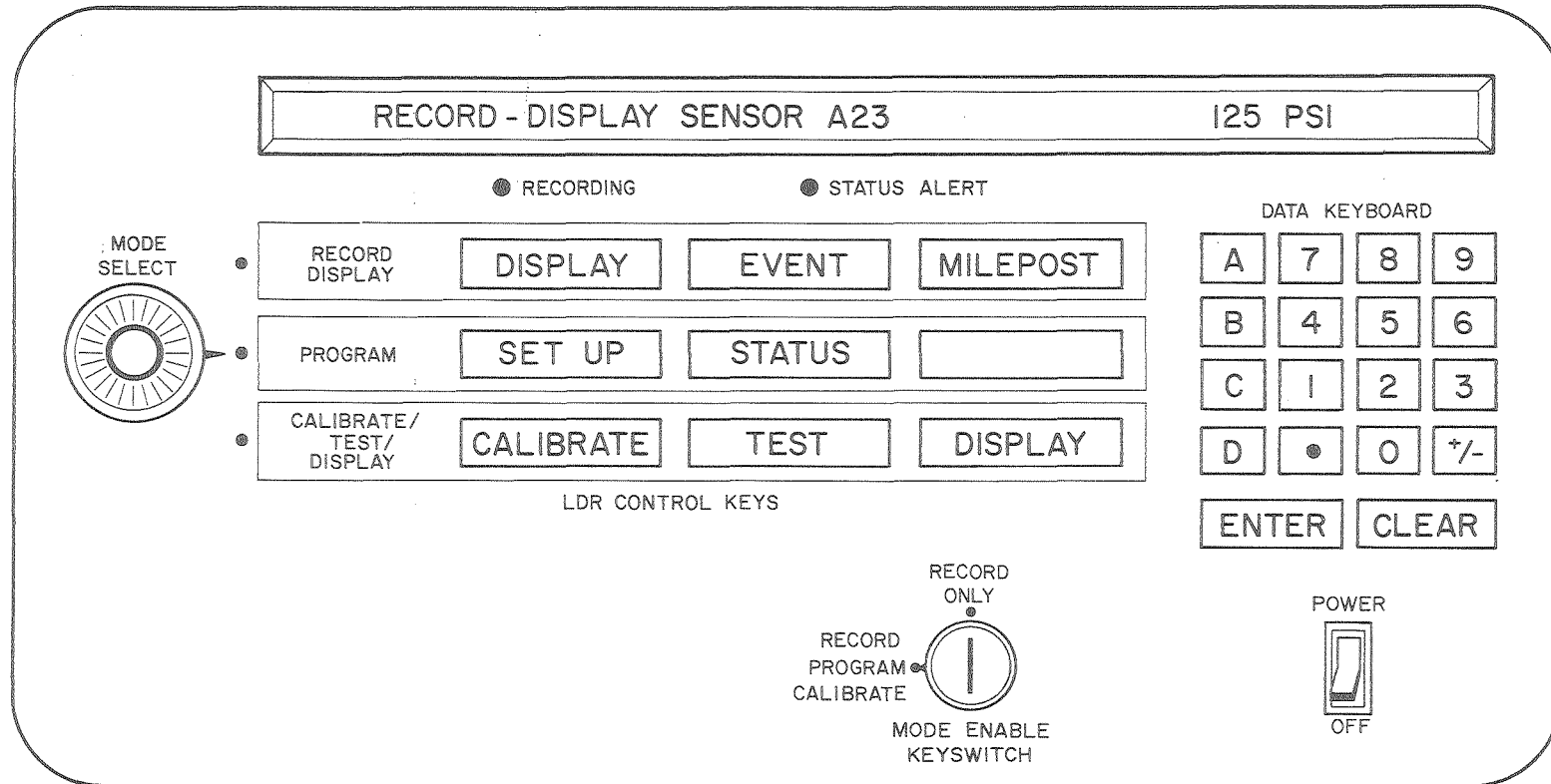

-22-

XBL 784-8093

Figure 3. Conceptual Design of a Front Panel for the LDR. Operator Controls and Indicators Are Shown.

3.3 LDR FUNCTIONS

The basic function of LDR is to record designated locomotive parameters onto magnetic tape in accordance with a preprogrammed sequence. To enable this to be done conveniently, it provides the controls and features to permit an operator to modify certain aspects of the preprogrammed sequence, to initiate and terminate operations, to monitor the progress of the test, and to manually input certain pieces of data.

To accomplish these functions the LDR will consist of one or more microprocessor-based* system controllers, a set of compatible data acquisition and conversion modules, a digital cartridge magnetic tape recorder, front panel controls and display, and a power supply.

In typical microprocessor fashion, these components are electrically interconnected inside the LDR package by means of a digital bus structure. A block diagram illustrating this configuration is in Figure 4. The broad line represents the digital bus. It consists of a number of wires carrying digital signals. Control of the entire ensemble is exercised by the microprocessor (via the digital bus) in response to the execution of instructions contained in its preprogrammed control memory. In response to these instructions, other signals, in the form of digital (binary) data, are carried (again via the bus) from sensor interface to data memory and from data memory to the digital recorder interface.

The majority of signals generated by sensors and transducers are

* The terms microprocessor and microcomputer are used more or less interchangeably in this report.

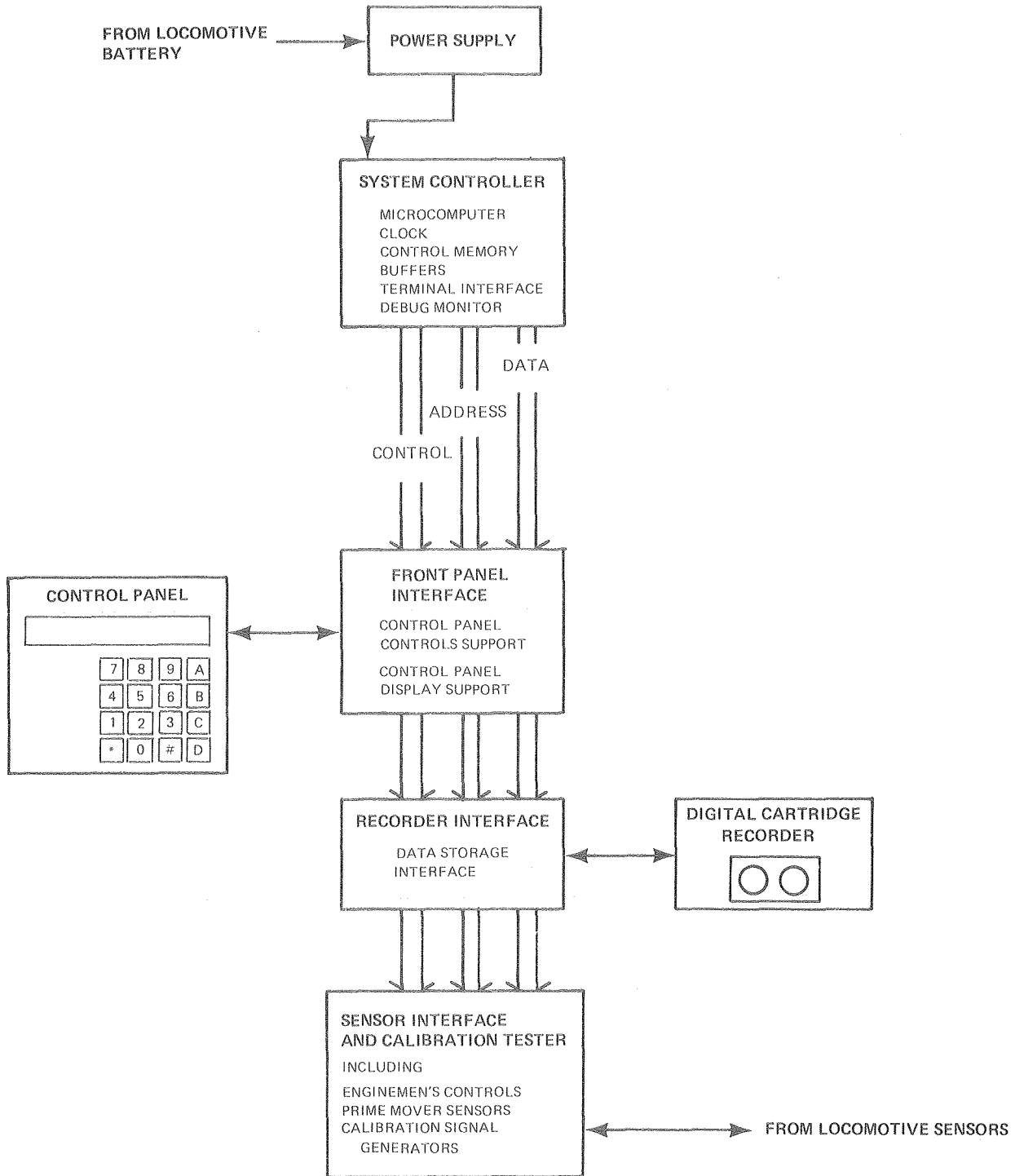

XBL 789-2234

Figure 4. Block Diagram of the Digital Bus Structure of LDR.

of analog variety. Analog signals carry information in terms of the magnitude of the signal voltage. For example, a one-volt signal might indicate 100 lbs of brake-line pressure, a two-volt signal might indicate 200 lbs, etc. For convenience in reliably transmitting and recording the information contained in such a signal, the information is converted to digital form as early in the processing as possible. The analog-to-digital conversion is one of the functions of the Sensor Interface element shown in Figure 5.

The basic sequence of operations is as follows. In response to a command transmitted by the microcomputers, the sensor interface will select a particular sensor signal, perform an analog-to-digital conversion on the signal, and store the resulting digital number temporarily. In response to a second microcomputer command, the digital number is transferred to the portion of memory used to store data. When sufficient data are stored in the memory, they are transferred in a block to the magnetic tape. Successive blocks are stored on tape until the run is completed.

Details of certain aspects of this process are given below.

3.4 LDR SENSOR INTERFACE

The sensor interface of the LDR provides the electronics necessary to operate and measure the transducers which in turn are connected to the locomotive parameters of interest. The sensor interface must be able to accommodate each of the dedicated sensors for the basic 16 parameters as well as the optional measurement types shown in Table 2.

The interface allows the system controller to initiate a measurement of any sensor, and to transfer the result of the measurement, in digital form, from the interface to the controller for further processing.

The block diagram of the input (signal conditioner) section of such a sensor interface is shown in Figure 5a. The output of the sensor is represented by the voltage generators on the left. Transducer excitation voltage is provided by the interface if required.

The signal conditioner provides two functions. First, the input protection filter rejects noise on the analog signal and protects the following delicate circuitry from the very large transients* that may be induced by the locomotive power circuits. The filtered signal is then amplified or detected by an appropriate signal conditioning amplifier. Transducers that require special signal processing, such as ac detectors or very high-gain amplification, will receive that processing at this point.

In the digitizer, shown in Figure 5b, the amplified signal is applied to a multiplexer, along with other inputs. Since the signals generated by different sensors will have different voltage ranges (spans) a programmable gain amplifier may be used to normalize the ranges before the signals are applied to the converter. This amplifier is programmable in the sense that its gain can be controlled by the microcomputer. The signal voltage is thereby amplified to the appropriate level for the sample-and-hold amplifier, which freezes the input signal on command.

* Transients as large as several thousand volts on open wiring have been reported to us by railroad personnel.

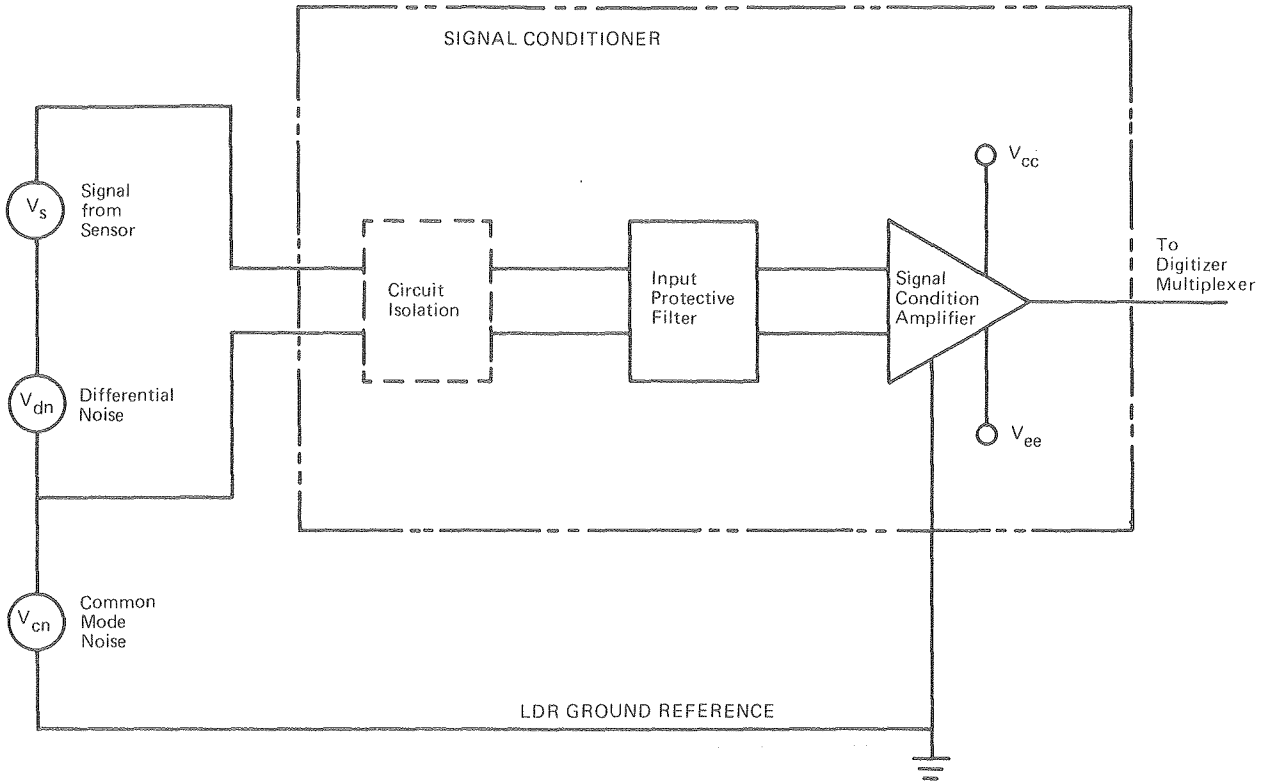

(a)

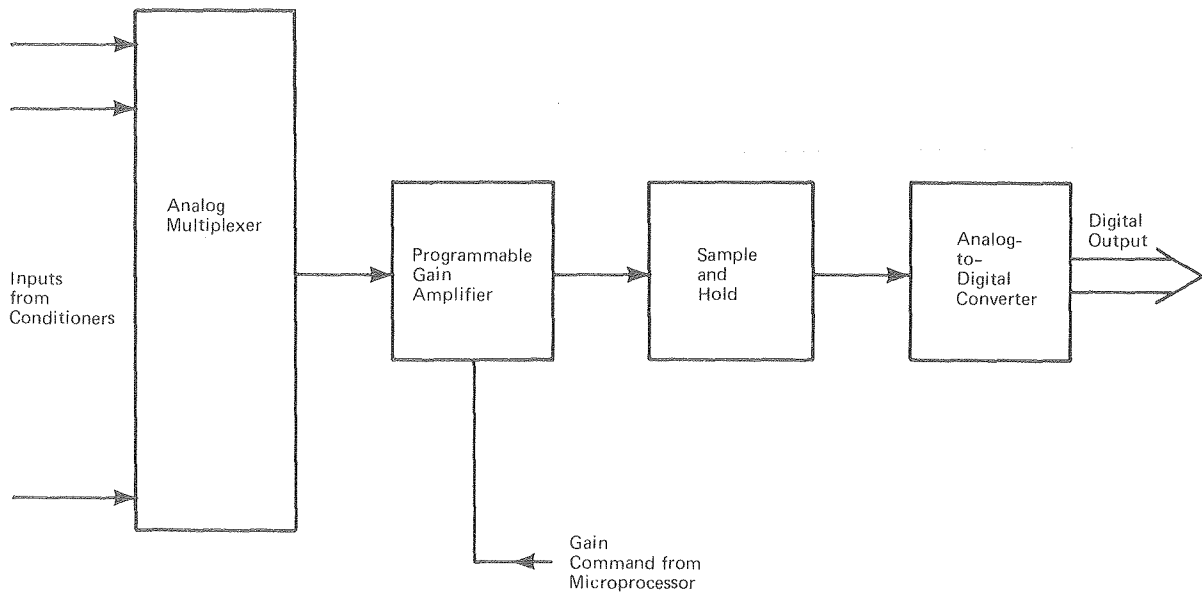

(b)

XBL 789-2230

Figure 5. LDR Sensor Interface: a) LDR Sensor Connection, and b) Multiplexer and Analog-to-Digital Converter.

The analog-to-digital converter converts the analog input signal to a digital output.

Digitizers having these characteristics are commercially available in microprocessor-compatible versions. A certain amount of signal conditioning is provided on these digitizers, though by themselves they may not offer protection against strong electrical interference.

Two types of interferences are typically encountered: common-mode and differential-mode interference. To illustrate, in Figure 5a the signal conditioning amplifier is shown with three voltage sources. They are:

- a. V_s , the signal source from the transducer. This is the signal that the LDR is designed to measure;
- b. V_{dn} , the differential-mode noise source. This noise is applied to the signal conditioner along with V_s , the signal of interest. It can be generated in the sensor, or anywhere in the cables and connections between LDR and sensor; and
- c. V_{cn} , the common-mode noise source. This noise is applied between the LDR ground reference and the signal reference. It can be induced in the connecting cables, or it can be inherent in the sensor signal, as with the measurement of the locomotive main alternator current by using a current-shunt in series with the alternator output.

V_{dn} and V_{cn} interfere in two respects. They may cause errors in the measurement. If the values of V_{dn} and V_{cn} are sufficiently large, they can damage the equipment. Circuit protection must therefore be designed so that neither V_{dn} nor V_{cn} in Figure 5a exceed the specifications given for the signal conditioning amplifier. Typical commercially available amplifiers allow neither voltage to exceed the power supplies V_{cc} and V_{ee} , which are often ± 15 V. Greater protection range for differential noise can be provided by the input

protective filter. It may include suitable attenuation of full-scale signals, low pass filtering to reject high amplitude-short duration noise spikes, and special protective devices such as varistors or fuses. Greater protection for common-mode noise can be achieved in some cases by suitable amplifier and cable connections. Extreme conditions, such as measuring a 10-V signal with a 600-V common-mode component, require a special circuit isolator to be installed in front of the amplifier. Opto-isolators and transformers are common techniques used to implement isolation of large common-mode voltages. Such techniques can easily isolate interference greater than 10,000 V. However, they are not compact or cheap, and so should be used only as required.

3.5 THE DIGITAL CARTRIDGE RECORDER

The digital recorder is the key element of the LDR, in that it performs the ultimate function of the device -- the recording of the time history of the locomotive parameters. To satisfy the system performance requirements, the recorder must offer high storage capacity and high reliability in the locomotive environment.

To fulfill this function we are investigating the use of a recorder that employs the 3M-type DC300A cartridge. Such recorders are made by several manufacturers to ANSI/ECMA/ISO standards, and can store up to 2.5 million bytes* of data. This is about three days of recording for the basic 16 locomotive parameters shown in Table 2. This standard device was designed specifically as a high density, compact digital recording medium. It has advantages in terms of reliability

* A "byte" is a group of eight bits of information.

and capacity over the Phillips-type data cassette and in terms of size and power burden over conventional seven-track or nine-track reel-to-reel digital tape recorders.

Manufacturers of recorders that use the DC300A cartridge offer a range of levels of environmental protection. Even so, the recorder is, still, the most delicate component of the LDR. For this reason tests must be performed to determine what additional measures must be applied to assure reliable recorder performance in the locomotive environment. Factors of concern are the susceptibility to airborne oil, smoke, and dust; shock and vibration; electromagnetic interference; temperature; and humidity.

In addition to the mechanical protection, the reliability of the recorder can be augmented by the program with which the system controller operates it. This is done by calculating a number, called the Cyclic Redundancy Character (CRC), which is uniquely dependent on the block of data being recorded. The CRC is recorded on the tape along with the data. When the data is read back from the tape, the CRC can be recalculated to determine whether the data was correctly recorded. If an error is found, the data can be re-recorded until no errors are indicated.

3.6 CONTROL AND DATA MEMORY

The sequence of operations that the LDR will perform in any locomotive test is determined by the control program of the microcomputer system controller. The control program is written in advance of the test and is loaded into the control memory of the microcomputer.

Because it is essential that the control program remain intact and unaltered during the complete locomotive test, essentially all of it will be stored in non-volatile, programmable read-only memories (PROMs). These are digital integrated-circuit memories that can only be read, i.e., their contents cannot inadvertently be changed by writing into them (except during the time the program is being initially loaded). They are non-volatile in the sense that the stored program is not lost when power is turned off.

The control programs that are to be loaded into the PROMs will usually be prepared in advance on a microcomputer development system. During Phase II of the LDAP program, this development system will be commissioned, some of the preliminary locomotive test programs will be developed, and complete instructions for developing other programs will be written.

The changing of the control program from one test to another can be as simple as unplugging one set of PROMs and plugging in another set which has been loaded with the control program for the new test.

The microcomputer will also contain a certain amount of read-write memory, typically called RAM. This will be used for storing certain control program information that is entered (via keyboard) at the time the test is run. RAM is also used for storing the data resulting from measurements. At one time this data is written into the RAM; at another time it is read from the memory and put onto magnetic tapes.



4. PACKAGING FOR THE LOCOMOTIVE SHOCK AND VIBRATION ENVIRONMENT

4.1 INTRODUCTION

The problem of vibration isolation is concerned with the inter-relationship of three subsystems: the vibration source, the equipment to be isolated (receiver), and the vibration isolator which is interposed between the source and receiver. The vibration source at the point in the locomotive where the equipment is mounted is characterized mainly by its vibratory motion and by its pertinent mechanical properties. These properties include the mechanical impedance, which is determined by the mass, stiffness, and damping factors of the car body structure at the mounting location. Since all the potential mounting locations for LDAP in the locomotive car body have finite rigidity, the motion of the source (which is the input to the isolator-receiver combination) is affected by the load impedance (mass, stiffness, etc.).

In subsection 4.2 we discuss the environmental specification (the vibration source) selected for LDAP and our reasoning in arriving at that specification. Subsection 4.3 discusses equipment (the receiver) fragility and the need for isolation, subsection 4.4 the planned mounting technique, and subsections 4.5 and 4.6 the isolators themselves. Lastly, subsection 4.7 discusses our test program.

4.2 INPUT SHOCK AND VIBRATION SPECIFICATIONS

The mechanical vibration environment for the LDAP is defined by two basic vibratory inputs to the locomotive car body structure -- that from the track and that from on-board rotating machinery (diesel engine and auxiliaries) which is typically hard-mounted to

the car body. On-board equipment can cause structural excitations in all directions at many frequencies; for example, a single rotating imbalance present in a diesel engine idling at 315 rpm could cause significant vibration at 5 Hz, and, at the higher end of the spectrum, the firing frequency of a 16-cylinder, two-stroke-cycle diesel engine is 240 Hz at maximum speed.

Road-bed caused excitations are primarily in the vertical (from track irregularities) and transverse (from wheel hunting) directions. Rail joints and special work (e.g., frogs) are a major source of vertical vibration input to the locomotive suspension and car body structure. For example, at 50 miles per hour speed, the rail-joint-contact frequency is approximately 1.9 Hz for a 39-foot rail, and, since the joints are staggered, the actual contact frequency would be nominally doubled, the inputs alternating between the right and left wheel-sets. In addition to the translational modes excited by the road bed, the locomotive car body can roll and pitch on its suspension from both track unevenness and mode-coupling because the center of gravity of a typical locomotive is located high above the elastic center of the suspension. The literature indicates that the typical spectrum for the car body forcing frequencies are 2.5 to 7.5 Hz from the suspension system, 50 to 70 Hz from car body structural resonance, and 5 to 300 Hz from the rotating machinery. Average road bed-caused amplitude is listed as 0.25 G with peaks reaching 1.5 G.² Rotating-machinery-caused amplitude will probably be less than 0.05 G.³

Longitudinal (fore-aft) vibration is primarily attributed to the shock transmitted through the locomotive draft gear. Velocity shock

can be used as a model to approximate the sudden "bottoming" of a locomotive draft gear.⁴ Velocity shock (also called a velocity step or an acceleration impulse) occurs in equipment when a sudden change occurs in the magnitude and/or direction of linear velocity. For example, a package dropped on the floor experiences a sudden velocity change at the instant the package is stopped by contact with the floor. Typical values for longitudinal velocity shock encountered in railroad equipment range from 50 to 100 inches per second.⁴ The former value would be approximately equivalent to dropping a body three inches onto a fixed support with no rebound and the later value would be attained by a similar 15-inch free fall.

The literature-based⁴ shock vibration values are summarized below:

- a. Shock (buff and draft)
50-100 inches per second velocity shock
- b. Vibration (road-bed input)
0.25 - 1.5 G in all directions; 2.5-7.5 Hz harmonic
50-70 Hz harmonic
- c. Vibration (prime mover input)
0.05 G all directions; 5-300 Hz harmonic

The above literature-based shock and vibration data was supplemented with estimates of the locomotive shock and vibration environment provided by several railroad properties. A summary of the worst cases estimated is tabulated below:

- a. Shock (buff and draft)
3 G longitudinal, 300 msec, half-sine pulse
- b. Vibration (road-bed input)
0.3 G longitudinal, 0-10 Hz harmonic
1.5 G transverse, 0-10 Hz harmonic
1.0 G vertical, 0-10 Hz harmonic

The 3 G, 300 msec, half-sine pulse is severe because of the long duration.

For example, to obtain a shock transmissibility of 0.5 (-6 dB) for the 300 msec pulse duration, a passive isolator system (assuming it has enough travel not to bottom) would need a horizontal undamped natural frequency of approximately 0.25 Hz for a 100-pound suspended package weight. For a suspension using four isolative units, the horizontal spring rate of each isolator would need to be approximately 0.16 pounds per inch. This "soft" rate would not be practical for a passive system to support, in a stable manner, the static weight of 100 pounds. In one reference a 10 G, 30 msec shifted-cosine pulse (gives less velocity change than a same-duration half-sine pulse) is a recommended shock level for the design of equipment to be shipped by rail.⁵ An isolator system designed to attenuate this input pulse down -16.5 dB (which is the same as 3 G attenuated 6 dB from above) would need an undamped horizontal natural frequency of approximately 2 Hz. For the same package weight and number of isolators as in the above case, the horizontal spring rate of each isolator would be approximately 10 pounds per inch, a spring rate near the practical limit attainable (for this specific application) by metal coil springs. If the same spring rate is used in the vertical direction (assume all six vibration modes are decoupled), the package would experience a 2.45-inch static displacement. This figure is a very large static deflection, comparable to deflections of low-natural-frequency automotive suspensions. However, through proper design, the isolator system could be configured to minimize the large spring size, surge, and lateral instability that can be typical of low-natural-frequency passive isolator systems.

In an attempt to unify the literature and field data for the input

shock and vibration specification a recognized military standard was selected to at least equal the levels and spectrum of literature and field vibration data. For shock pulse duration and low frequency accelerations, the standard is less severe than the levels of reported field data. However, in those cases the standard's levels were more in agreement with what the rail equipment was capable of producing (e.g., suspension travel or reasonable coupler impact velocity for a locomotive). The shock (with increased pulse duration) and vibration specifications in Military Standard 810C for equipment installed in ground vehicles met the above requirements for a general specification. Of the three test curves in the specification for ground vehicles, test curve W, extended down to 1 Hz frequency (see Figure 6), was selected for the vibration specification for LDAP. The magnitudes and spectrum are presented below in Table 3:

Table 3. MAGNITUDES AND SPECTRUM OF THE VIBRATION SPECIFICATION SELECTED FOR LDAP.

<u>Point</u>	<u>Frequency (Hz)</u>	<u>Double Amplitude^a Displacement (in)</u>	<u>Acceleration^b Amplitude (G)</u>	<u>Case</u>
1 ^c	1	3.0	0.16	----- A
2	3.1	3.0	1.5	----- B
3	30	0.033	1.5	----- A
4	50	0.033	4.2	----- B
5	500	0.00033	4.2	

(a) Harmonic vibration

(b) Case A - constant amplitude between points

Case B - constant acceleration between points

(c) Low-frequency extrapolation

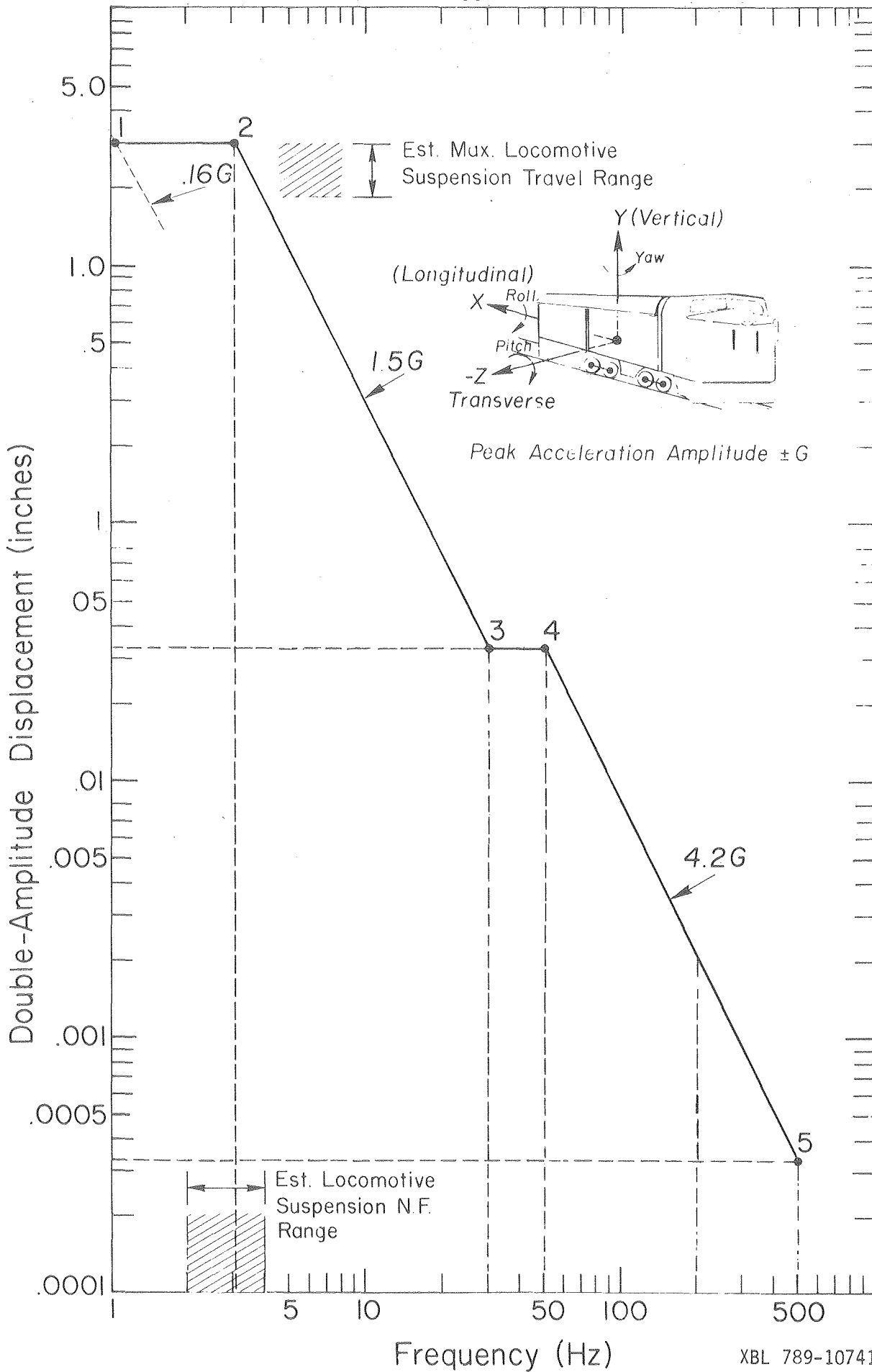
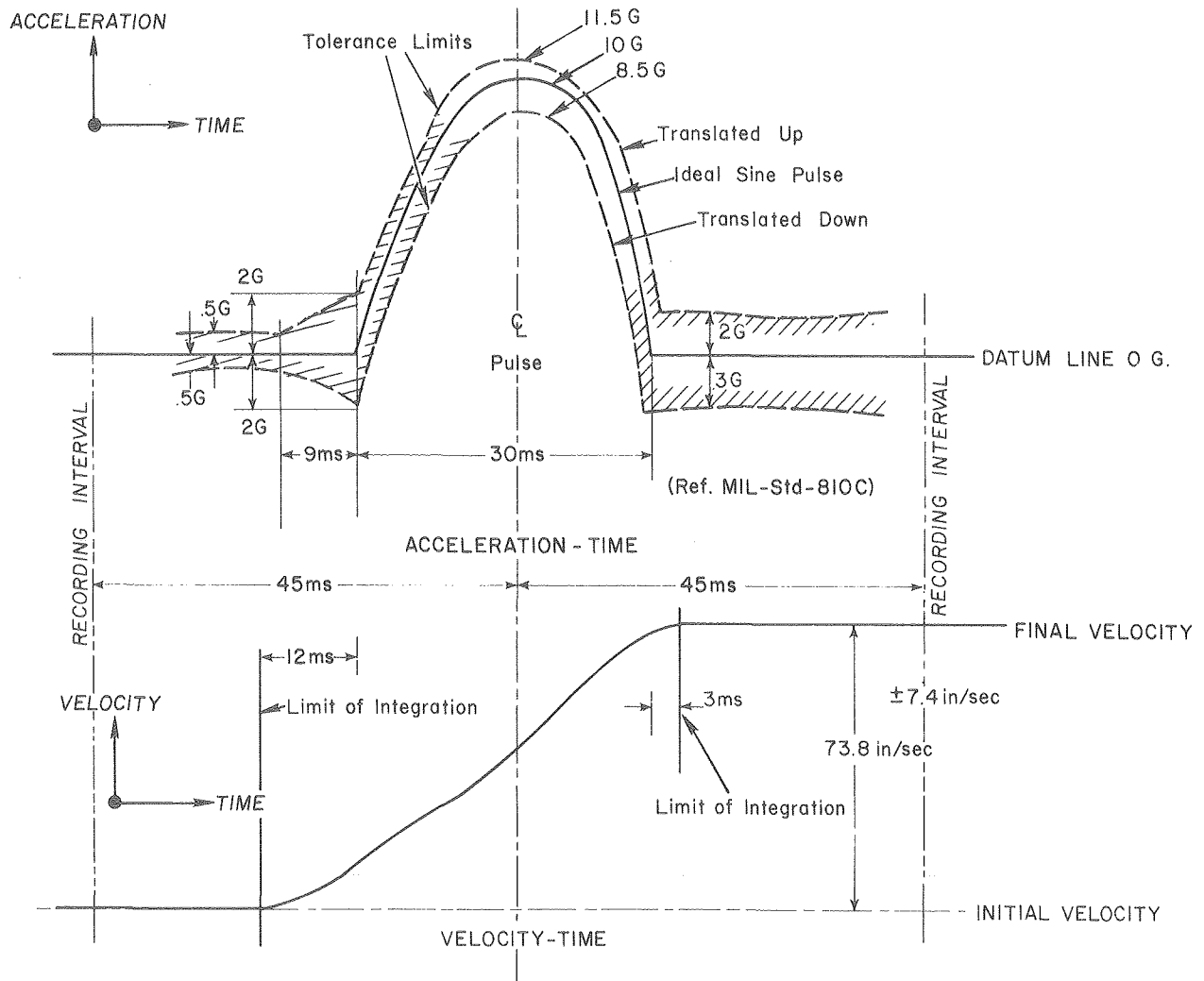

Figure 6. Source Vibration Specification for LDAP: X, Y, and Z Directions.

The test curve extends above the normal 200-Hz limit (specified for ground vehicles) to include the higher frequency inputs from, in the locomotive case for example, the firing-frequency of multicylinder locomotive engines (approximately 300 Hz max).

The half-sine pulse shock shape specification of Mil-Std-810C with the 10 G magnitude and 30 msec duration used in Reference 5 is a reasonable longitudinal shock specification when the resulting change in velocity is considered. A half-sine pulse will ramp the velocity change by the time duration of the pulse. In contrast, a pure velocity step or acceleration impulse requires an infinite acceleration occurring over an increasingly small time interval. From Figure 7, a half-sine pulse of the above-specified magnitude and duration will cause a velocity change of 75 inches per second (4.3 mph) over a ramp-up time of 30 msec. Note that the 10 G, 30 msec shifted-cosine shock pulse of Reference 5 will cause a velocity change of 58 inches per second (3.3 mph) which is less severe, for the same level and duration, than the velocity change caused by the more commonly specified half-sine pulse waveform.

Figures 6 and 7 graphically summarize the modified Mil-Std-810C shock and vibration specification for LDAP. Note that a specification has not been included for the displacement or acceleration spectral density to quantify the random portion of the railroad vibration environment. An estimate of the random vibration content will be included in the later section on the proposed test plan for LDAP. During the test phase an examination of the effects of simultaneous excitations of structural natural frequencies will be conducted.



XBL 789-10737

Figure 7. Shock Specification for LDAP: X, Y, and Z Directions.

4.3 EQUIPMENT FRAGILITY; THE NEED FOR ISOLATION

In isolator system design it is important to characterize the mechanical impedance and fragility of the equipment being isolated. To make the design problem manageable, an initial approach will consider the receiver impedance to be adequately represented by a simple mass load. Consideration must also be given to the location of fragile components inside the receiver. Defining the environment as the vibration source, both the source and the fragility of the receiver can be described as surfaces of hills and valleys on a three-dimensional plot. In such a plot length and width of the surface correspond to the axis directions of vibration frequency and time. The height of the surface and the thickness of the undulations respectively represent the mean amplitude of the vibration and its standard deviation. Probability of receiver damage is minimized when the "fragility surface" is much higher than the "environmental surface" (vibration source) and both surfaces are relatively thin.

For analysis of the LDAP mounting system, the source admittance is assumed to be zero and therefore, the source impedance will be infinite. The fragility plot for the receiver is based on the vibration tolerances for the digital magnetic tape recorder and is shown in Figure 8. Note that the fragility envelopes shown in the figure do not cover the full expected frequency range of the environment. In order to make a more detailed assessment of equipment fragility, the data supplied by the two recorder manufacturers (Tandberg and D.E.I.) will need to be extended in both frequency and amplitude. This is of particular importance in evaluating the dynamics of the tape-to-

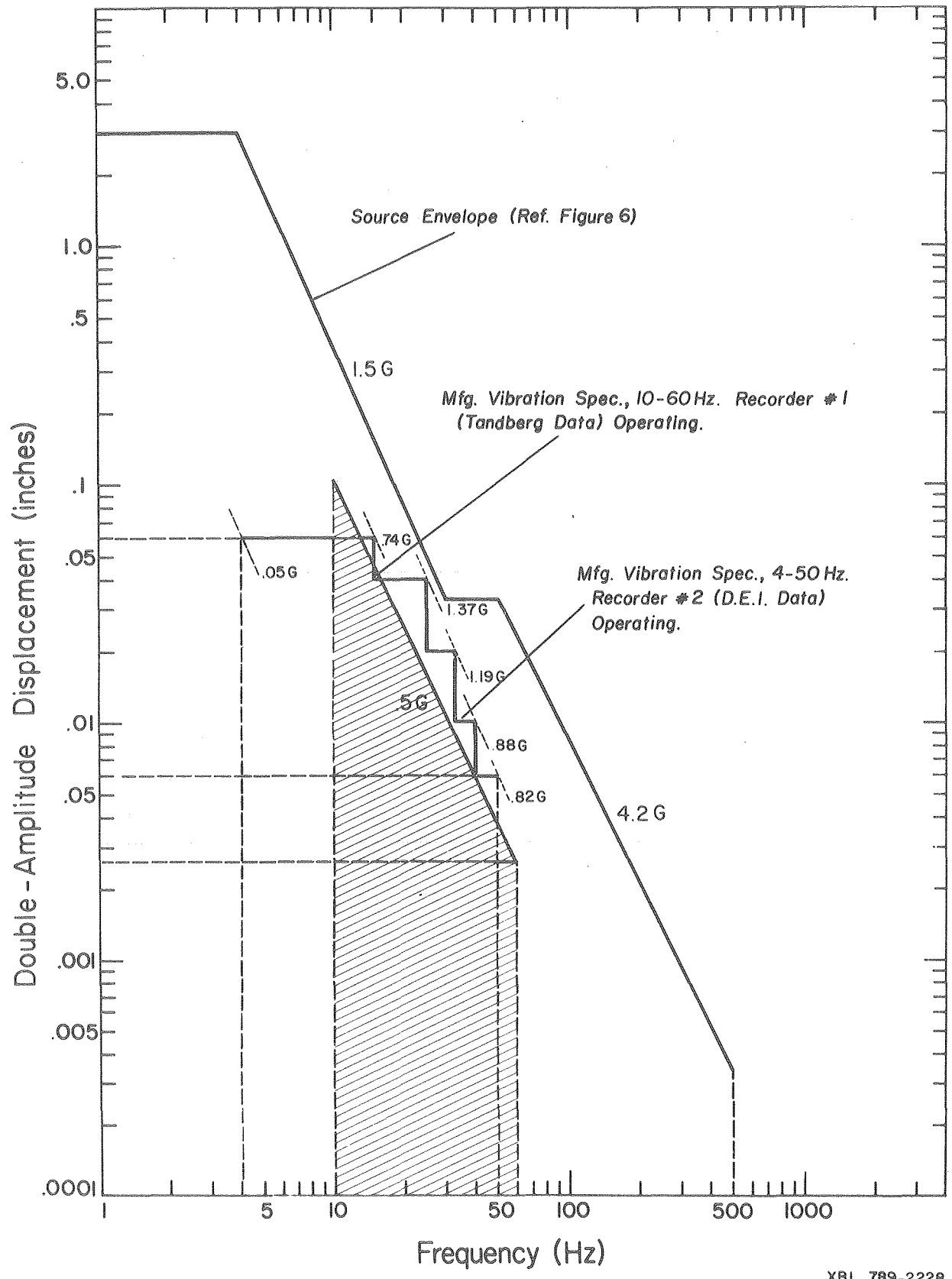

XBL 789-2228

Figure 8. Source and Fragility Envelopes.

recorder-head mechanical interface).

4.4 ISOLATION - A CENTER OF GRAVITY APPROACH

The following additional assumptions will be made in the design process of the LDAP isolator system.⁶

1. The major effects in a given direction of motion can be assessed by considering pure translation of the equipment in the given direction only. This consideration requires that the motions and admittances of the equipment support points are so nearly enough alike that they do not cause significant rotations of the equipment.
2. The vibration isolation system will be a "center of gravity" configuration to allow individual treatment of each of the three mutually perpendicular directions of motion.
3. Each of the vibration isolators may be described dynamically by a linear massless spring and an ideal viscous damper that are mechanically parallel.

The basic isolator system is schematically shown in Figure 9. Before the details of the isolator design are developed, a description of the center of gravity isolator configuration is needed.

The natural modes of vibration of a body supported by isolators may be decoupled one from another by proper orientation of the isolators. Each mode of vibration exists independently of the other, and vibration in one mode does not excite vibration in other modes. The necessary conditions for decoupling may be stated as follows: the resultant of the forces applied to the mounted body by the isolators, when the mounted body is displaced in translation, must be a force directed through the center of gravity, or the resultant of the couples applied to the mounted body by the isolators, when the mounted body is displaced in rotation, must be a couple about an axis through the center of gravity. Consider the system shown in Figure 10, where the principal elastic

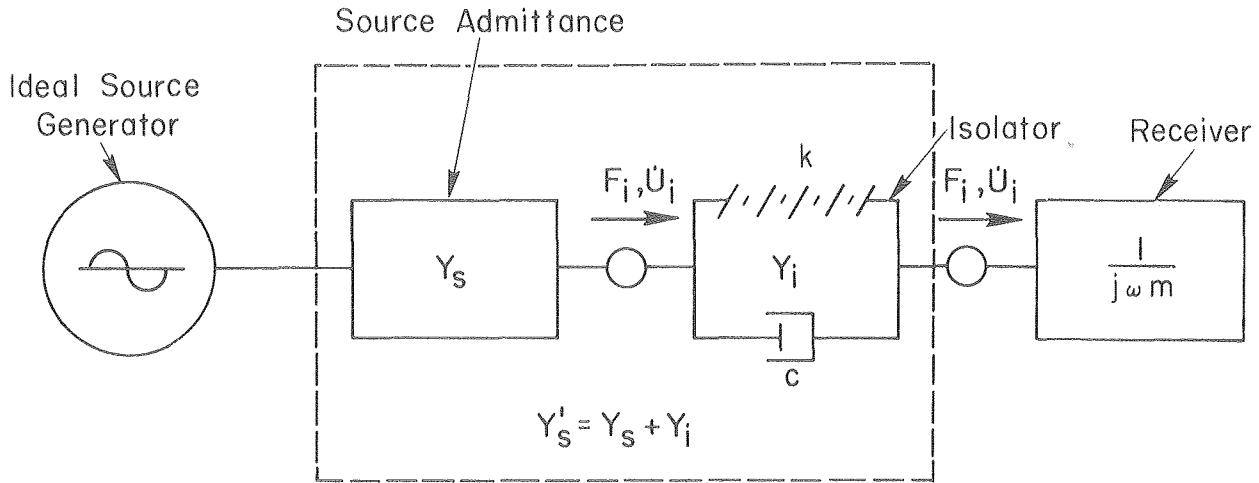

$Y_s \equiv$ Complex Source Admittance (assumed to be 0) $\left\{ \frac{\text{in/sec}}{\text{lb}} \right\}$

$Y_i \equiv$ Complex Isolative Admittance $\left\{ \frac{\text{in/sec}}{\text{lb}} \right\}$

$F_i \equiv$ Force (lb)

$\dot{U}_i \equiv$ Velocity $\left\{ \frac{\text{in}}{\text{sec}} \right\}$

$m \equiv$ Receiver Mass $\left\{ \frac{\text{lb}}{\text{in/sec}^2} \right\}$

$k \equiv$ Spring Constant $\left\{ \frac{\text{lb}}{\text{in}} \right\}$

$c \equiv$ Coefficient of Viscous Damping $\left\{ \frac{\text{lb}}{\text{in/sec}} \right\}$

$\omega \equiv$ Angular Frequency $\left\{ \frac{\text{radians}}{\text{sec}} \right\}$

XBL 789-10740

Figure 9. Basic Isolation System.

axes of the isolators are parallel and there exist two planes of symmetry (plane XY and ZY). The forces resulting from a deflection in the Y direction alone are symmetrical with respect to the center of gravity in both the XY and ZY planes. This symmetry in two planes automatically makes the resultant vertical force pass through the center of gravity and, therefore, automatically provides for decoupling of the Y-coordinate mode of vibration. In Figure 10 the forces resulting from an X deflection or a Z deflection are symmetrical with respect to the center of gravity only in the top view. The result of this is that the ψ -coordinate mode is also automatically decoupled, whereas the X- and Z- and ϕ -coordinate modes are coupled. Decoupling the X- and the θ -coordinate modes in the XY plane requires that the forces in the X direction be symmetrical about the center of gravity in the XY and XZ planes. This would imply that the only additional requirement for the system is that $b = 0$. However, d must also be zero to allow displacement in the X direction to be decoupled from the angle of rotation, θ . Therefore, since physically b cannot practically be made equal to d , it is apparent that complete decoupling of the coordinate modes is not possible when using typical isolator configurations (coil springs and the like). Nevertheless, if $b = -d$, the coupling will be minimal and in most cases if either b or d equals zero, the effect of coupling can still be ignored.⁷ Note that the above discussion applies also to the Z- and ϕ -coordinate modes in the ZY plane. Now having nominally "three planes of symmetry," the isolation system has all six vibration modes decoupled and can be designed to have the same natural frequency in all six modes (make the spring rates equal in the

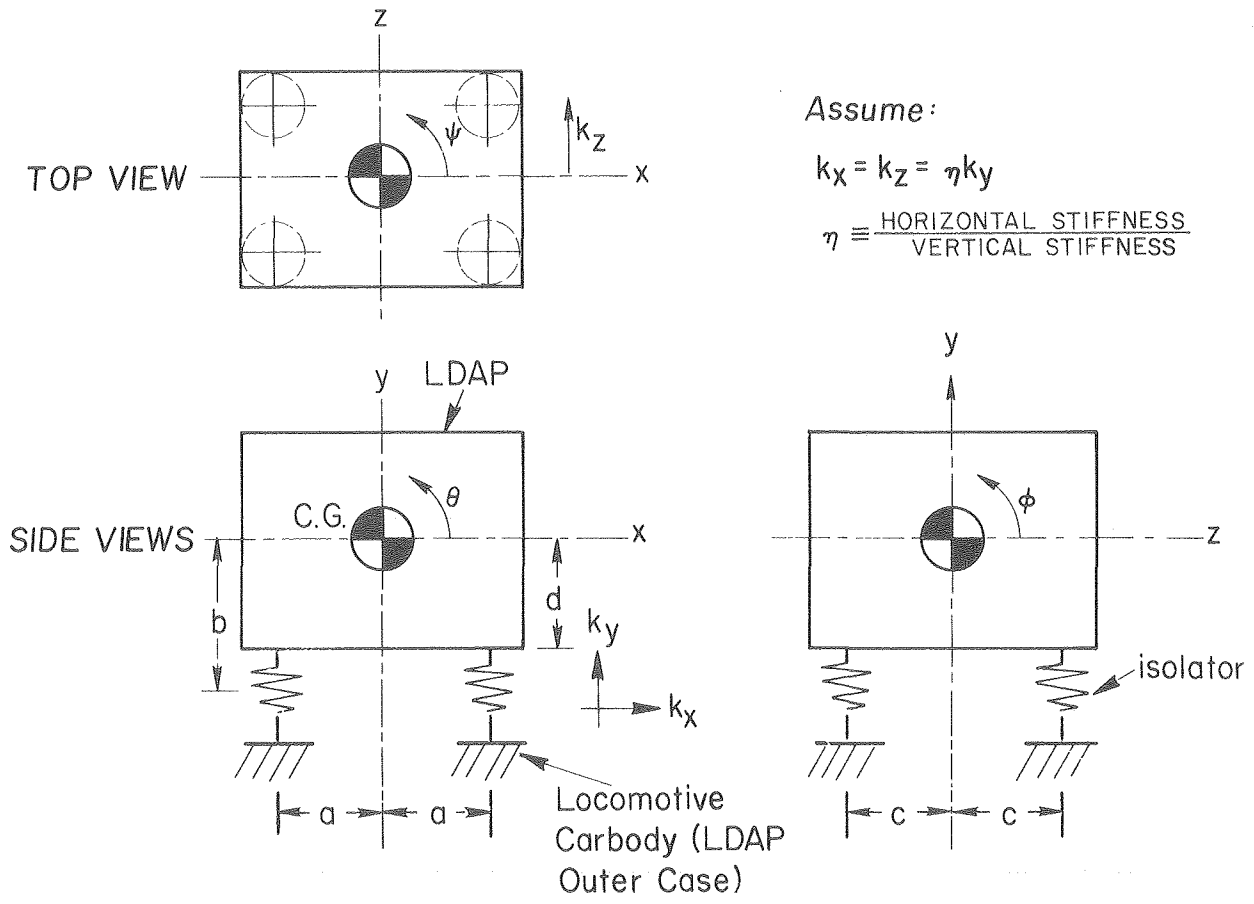

XBL 789-2233

Figure 10. Suspended LDAP Unit on Four Isolators.

horizontal and vertical directions and locate the isolator positions relative to the center of gravity, at distances equal to the corresponding radii of gyration). Thus designing the isolator system for three planes of symmetry can be useful when it is desired to keep the six natural frequencies close together.

4.5 SHOCK AND VIBRATION - GENERAL HARDWARE CONSIDERATIONS

The following categories of the isolator properties are significant for the proper design of the isolator subsystem:

- a. Linear dynamic performance along and about three axes.
- b. Load and deflection capacity.
- c. Strength and endurance.
- d. Resistance to deterioration in adverse environments (temperature, oil, etc.).
- e. Installation features.

With the selection of the center of gravity mounting scheme, each of the vibration modes can be analyzed independently. This greatly simplifies the analytical work required to design the isolator system when compared to that of a fully coupled system. The following discussion will briefly describe the methodology used to define the stiffness and damping parameters of the isolators.⁸ By assuming that each of the six modes can be analyzed as a single-degree-of-freedom system with the above two parameters, each isolator can be specified to a manufacturer by using three alternative methods:

1. Range of natural frequency and fraction of critical damping.
2. An envelope of transmissibility for the range of permitted parameters.
3. Ranges of spring constant and viscous damping coefficient.

Methods 1 and 2 are the most common, with method 2 having the advantage of not being affected by slight nonlinearities present in all "linear" practical isolators.

To begin the definition of the isolation parameters, the actual need for isolation of the equipment has to be verified. It is possible that the equipment could be "hard" mounted. On Figure 11 is shown a plot of the maximum allowable "transfer function", H_{ms} versus frequency. H_{ms} for harmonic input is defined as:

$$H_{ms} = \frac{U_f}{U_s}, \text{ where}$$

U_f = complex amplitude of input harmonic displacement expressing the fragility limit of the equipment, and

U_s = complex amplitude of output harmonic displacement of the source vibration.

This calculation becomes less complicated than that for the general case, since the source admittance is assumed to be zero. Any value of H_{ms} less than 1.0 implies a need for vibration isolation. Note that the values of H_{ms} were calculated from the averaged recorder manufacturer's specifications so that the values at the higher and lower ends of the frequency spectrum are extrapolations; tests will be done to insure that the actual equipment fragility limits will not be exceeded.

Now that it has been determined that isolation is required, a minimum natural frequency has to be established for the isolation system and the inertial properties of the suspended mass have to be defined (mass, center of mass, moments of inertia, and products of inertia) to establish the location of the mounts. From practical considerations,

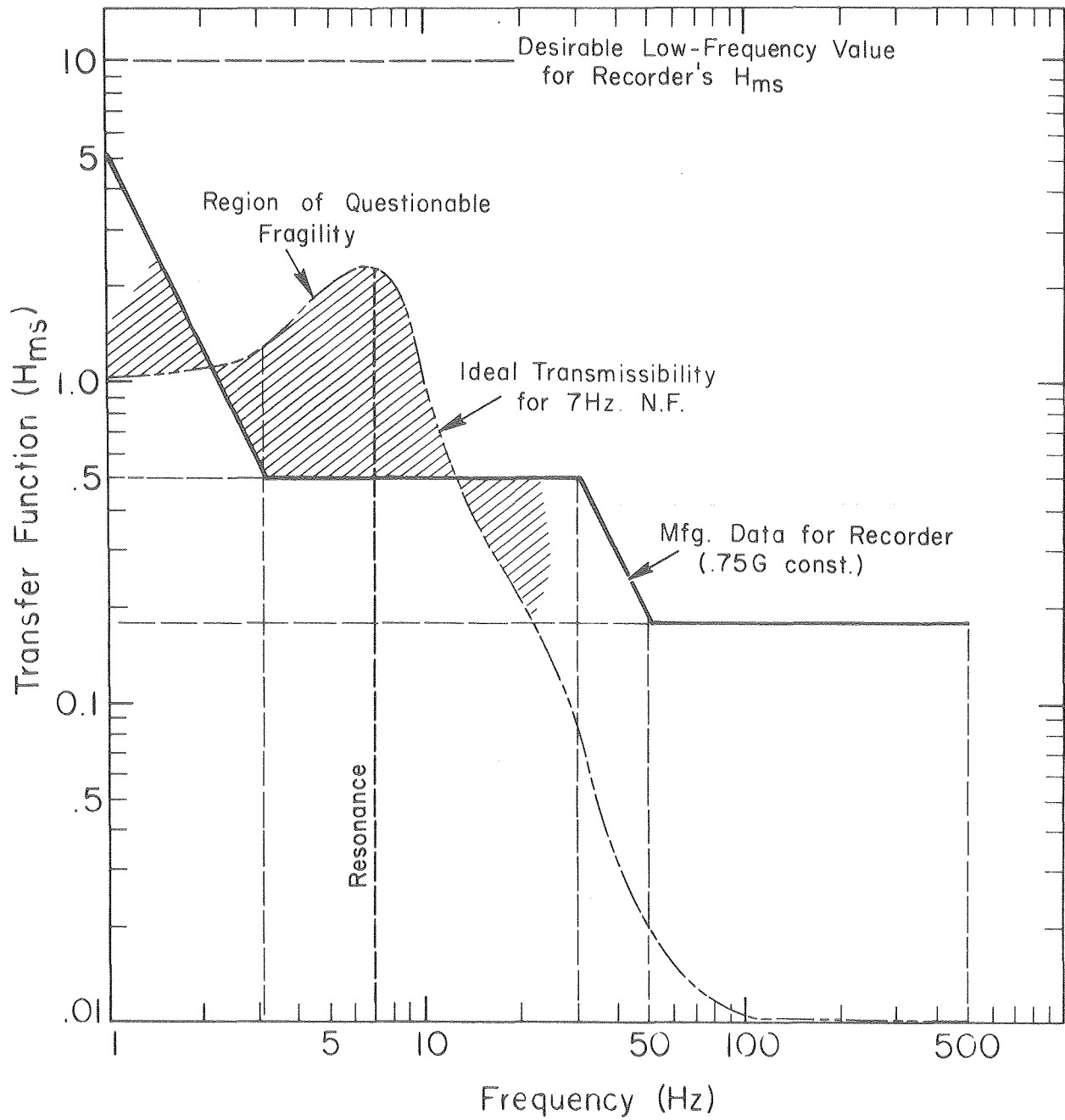

XBL 789-2232

Figure 11. Transfer Ratio Related to Frequency.

the system natural frequency has been selected at 7 Hz, $\pm 15\%$. This frequency will give a static deflection of approximately 0.2 inches. Isolation begins at approximately 10 Hz and attains 90% efficiency at approximately 40 Hz (see Figure 12). A lower natural frequency would, of course, be more efficient over the full spectrum but would risk resonance with the range of locomotive suspension natural frequencies and the 300 cycle-per-minute engine idling frequency. To illustrate the problem of low-frequency resonance, assume that the LDR isolator system has a natural frequency of 2 Hz and is driven at resonance with damping 25% of critical to control the maximum resonant amplitude. If a two-inch double-amplitude displacement is input at 2 Hz, the system will try to respond with approximately 5.0 inches of double-amplitude displacement which would be difficult to accommodate in a passive system without a large "rattle-space" or overstressing the spring element of the isolator. In contrast, at 7 Hz the typical input amplitude will be limited to approximately 0.25 inches so that a similar resonance condition will produce approximately 0.5 to 0.75 inches travel in the suspended mass.

One difficulty with the 7 Hz natural frequency is that the equipment will need to be able to withstand the direct coupling and amplification of the source displacement below approximately 10 Hz. With the manufacturer's recorder fragility specification of only 0.75 G at low frequency, the 7 Hz natural frequency of the isolator system will allow sufficient attenuation of the 1.5 G input starting at 20 Hz. A desired equipment fragility at low frequency, less than 15 Hz, would be at least 10 G's peak amplitude. If the recorder manufacturer's

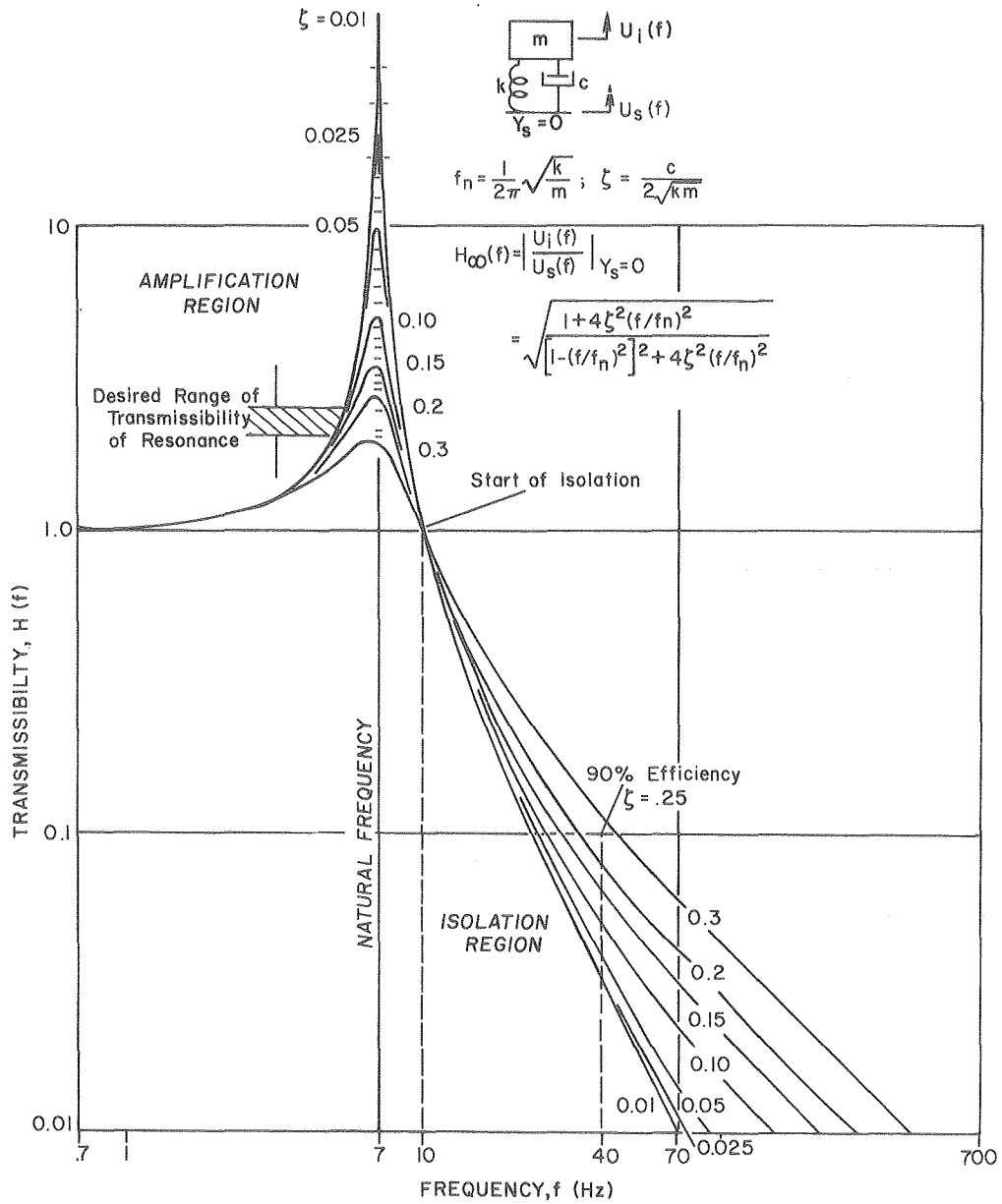

XBL 789-10738

Figure 12. Ideal Transmissibility for a Single Degree of Freedom, Viscously Damped, Linear System.

conservative low-frequency vibration specification is actually verified by testing (specifically of the recorder head-to-tape interface), ad-hoc ruggedizing of specific weak components would be more desirable than designing a low-natural-frequency, high displacement, "FREE-FREE" type of suspension.

Besides the vibration environment, the shock conditions on the locomotive will define a part of the isolator specification. Since shock is normally a transient phenomenon, the isolation of shock input is considerably different from that of a vibration input. The shock isolator is a storage device where input energy, usually with a very steep wave front, is instantaneously absorbed. The energy is stored in the isolator and released at the natural frequency of the spring-mass system. By assuming a damping coefficient of 0.25, the shock transmissibility of the 7 Hz isolator system responding to a 30 msec half-sine pulse would be about 0.8.⁹ When considered from the standpoint of a velocity shock, a step change in velocity of 75 inches-per-second would cause the most rigid parts of the equipment suspended on a 7 Hz isolator system to experience approximately 8.5 G peak with a 1.5 inch excursion. The shock specifications supplied by the recorder manufacturers for non-operating equipment correspond to velocity changes in the 125 to 200 inches-per-second range. Testing will be necessary a) to establish the shock limits while the recorder is running to insure that the 7 Hz isolation system will provide adequate protection, and b) to evaluate effects of snubbing since an actual isolator system will need a snubber transition region to avoid "hard bottoming" for severe velocity changes.

Although the exact inertial properties have not been established for the suspended equipment (tests will be required for accurate values), initial estimates place the suspended mass at $\approx 0.3 \text{ lb-sec}^2/\text{in.}^*$ and the radius of gyration in the length dimension at ≈ 10 inches and those in the height-width dimension at ≈ 4 inches.

4.6 SHOCK AND VIBRATION ISOLATION -- SPECIFIC HARDWARE CONSIDERATIONS

Since the proposed isolator system can be classified as a low natural frequency system, metal coil springs are being considered for the elastic elements of the isolator system. Metal springs are readily designed with ability to undergo large deflections without exceeding the safe working stress for the spring material. In contrast, a rubber isolator capable of sustaining large deflections is generally required to have large dimensions to attain a low unit strain. Metal springs also can endure large excursions of temperature without material degradation or large changes in stiffness.

However, a metal spring exhibits little internal damping when compared to that available in an elastomeric spring. Auxiliary damping is thus required in conjunction with a metal spring when operation at resonance is expected. A common damper used in the general class of viscous dampers is the dashpot. A piston is attached to the suspended body and is arranged to move axially through a liquid in a cylinder mounted to the source of input displacement. Through proper design, the force required to shear the fluid can be made nominally proportional to velocity, the magnitude of the damping force being controlled by

* Approximately 100 pounds.

the viscosity of the liquid and the radial clearance (requires precision tolerance) between the piston and cylinder walls. Although dashpots are probably the best behaved discretized dampers from the standpoint of analysis, they have several limitations: a) they typically act along a single axis, b) they tend to restrict motions not along that axis (unless additional equipment as spherical-end bearings are added), c) they require seals to prevent fluid leakage, d) damping properties vary with temperature (from fluid viscosity change), and e) they tend to be costly. Air can be used as the damping fluid to minimize the sealing problem and the viscosity change with temperature. With air damping a piston drives air through an orifice, and the work expended in forcing air through the orifice extracts energy from the vibrating system.

Energy can also be extracted from a dynamic system by allowing sliding contact between two members, one being attached to the suspended mass and the other to the source of motion. Dry-friction or coulomb-damping elements are less complex to construct than the precision-fitted components of a viscous system. However, on the the minus side the characteristics of coulomb damping are less adapted to analysis than those of viscous damping. Also, a coulomb damper will tend to reach a "transmissibility floor" at high frequency because the small deflection at high frequency makes the spring-force contribution small. At this point the nominally constant-force (amplitude independent) friction damper will tend to dominate the response of the suspended mass. With time passage the damping characteristics can change from wear and contamination of the rubbing surfaces with materials that alter the

friction properties.

Since viscously damped, metal spring isolator systems are the "best behaved" with respect to theoretical analysis and actual performance, they will be given first consideration for the LDAP isolator system. Figure 13 shows a custom designed, aerospace-quality, all-attitude, viscous-damped isolator with transmissibility curves showing temperature, amplitude, and isotropic performance. Note the consistent natural frequency in each of the sets of curves. Shown in Figure 14 is a leaf spring that has three discrete directions of compliance. Although the damping elements are not shown in the figure, the mutually orthogonal directions of stiffness reduce some of the problems of constructing a three-axis-decoupled damping system. A third option for the isolator is a friction-damped or air-damped coil spring system as shown in Figure 15. This configuration has an elastically coupled damper that allows the damping elements to reduce their interaction at high frequency as shown by the 99% isolation efficiency reached at 100 Hz. Their basic advantage when compared to the feature of the other two systems is low cost and availability from stock.

All of the design considerations for the isolators assume that both the suspended mass and the mounting base are significantly more rigid than the isolators themselves. The "mounting base" includes both the locomotive floor and an outer shell (see Figure 16). To insure that the protective outer shell of the recorder as well as the recorder case itself are "rigid" but lightweight, both enclosures will be fabricated from aluminum sandwich panels per Mil-Std-21200. The weight-to-stiffness advantages of sandwich panels are well known. For example, a half-inch

LORDCO DATA

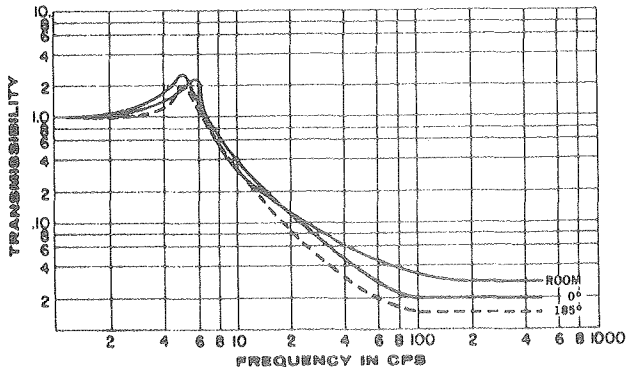

Temperature effect on natural frequency

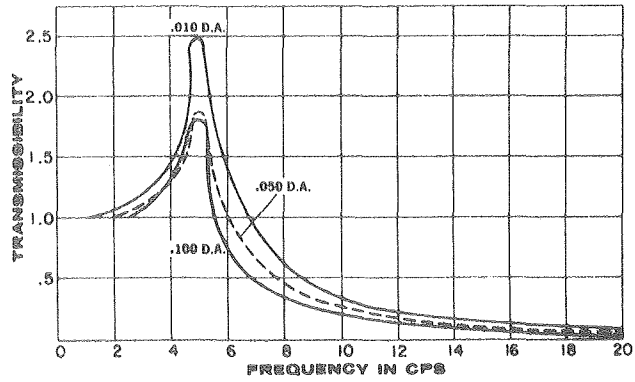

Displacement effect on natural frequency

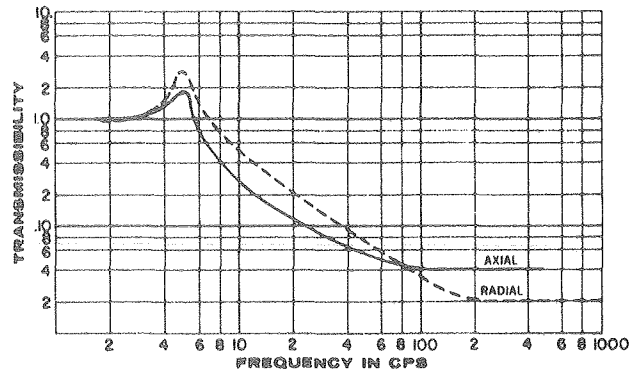
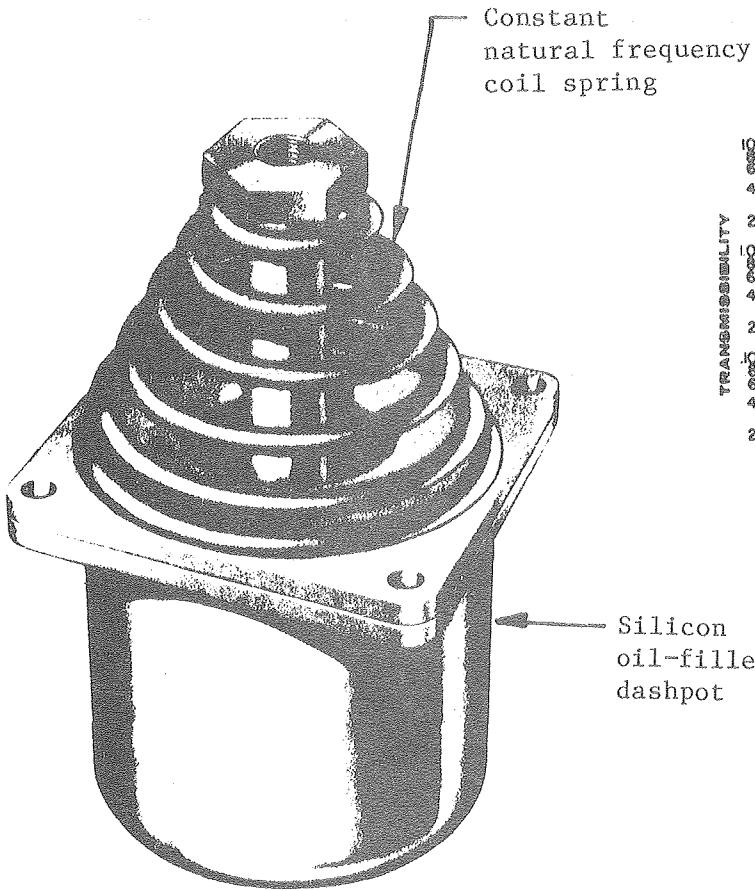

Direction effect on natural frequency

Figure 13. Viscous-Damped, All-Attitude Vibration Isolator.

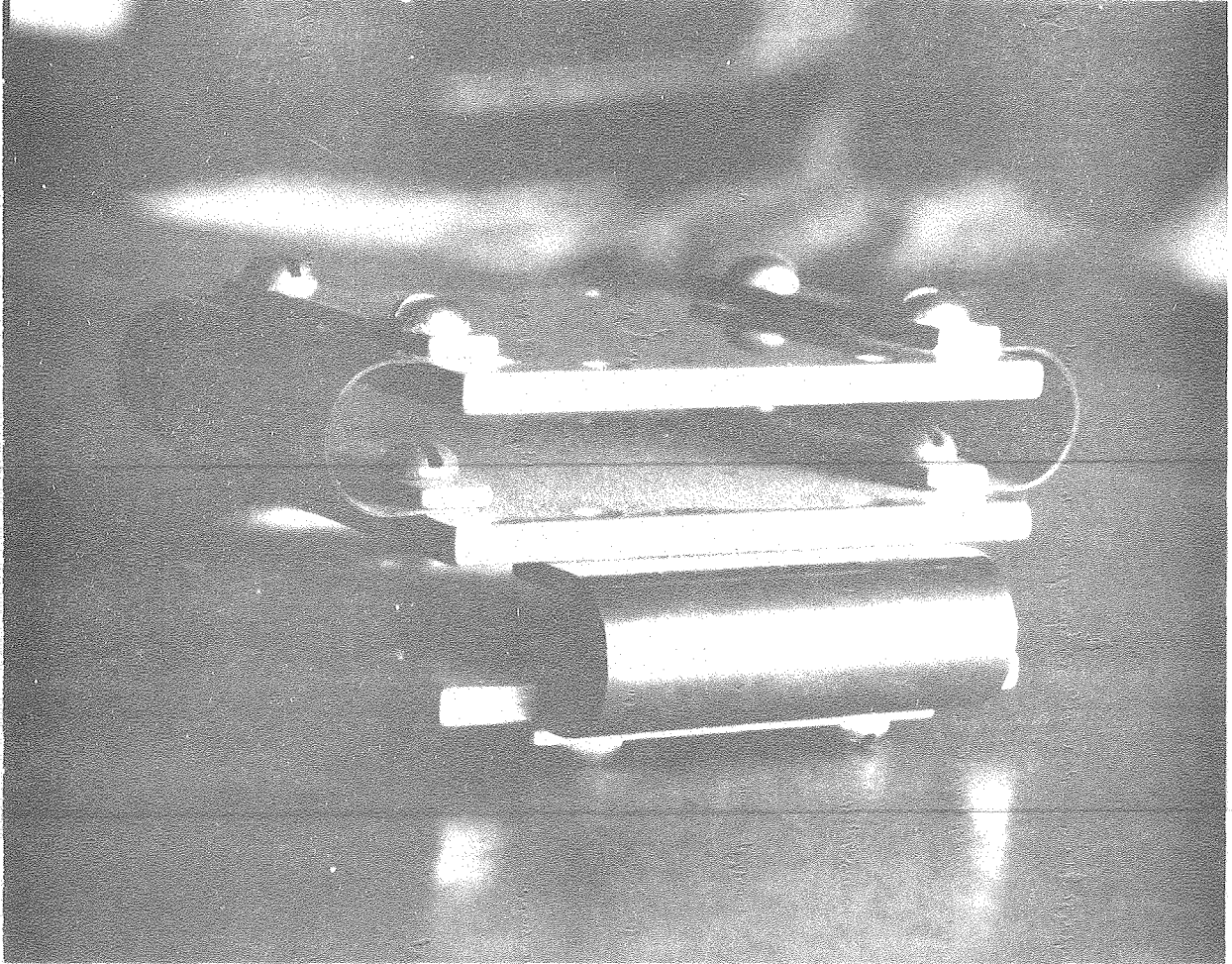
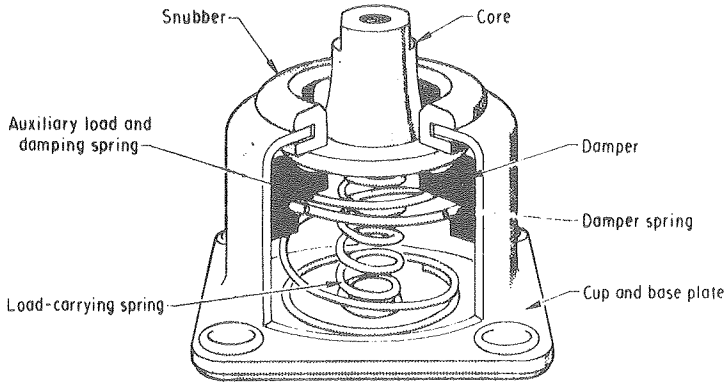

Figure 14. U-Type Leaf Spring Isolator.

Barry Wright Corp.



Friction-damped

TRANSMISSIBILITY vs FREQUENCY

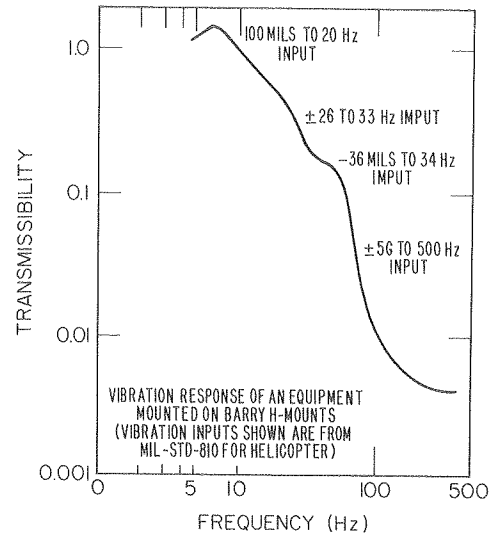

XBL 789-2235

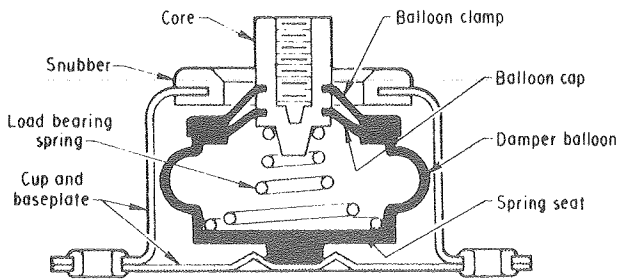

Air-damped

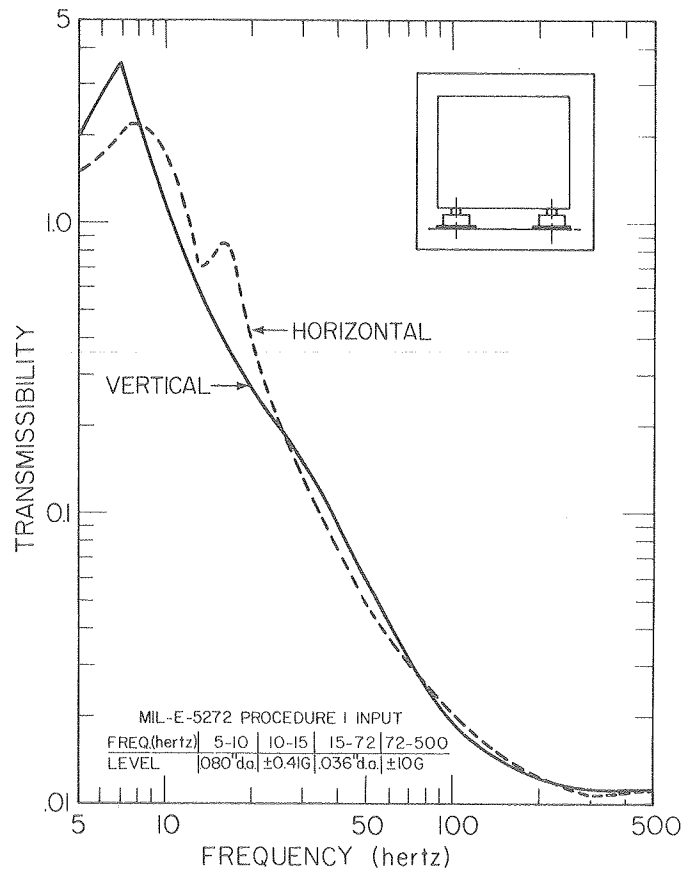

XBL 789-2231

Figure 15. Friction and Air-Damped Vibration Isolators.

thick sandwich panel with 0.032-inch thick aluminum faces has the effective stiffness of a 0.35-inch thick geometrically similar solid aluminum plate. However, the sandwich panel has less than 5% of the weight of the solid plate, assuming an aluminum honeycomb core is used in the sandwich. Figure 17 shows a cross section of a typical enclosure made to Mil-Std-21200 that utilizes sandwich panels with extruded aluminum edge closeouts and aluminum corner castings. For additional insurance against panel resonance deflections, the faces of the sandwich assembly can be treated with damping material.

A similar approach will be used to construct the inside shell that will be directly attached to the recorder equipment. All of the edge closeouts will be glued to the panels, and a conductive adhesive will be used to insure continuity in the electromagnetic interference (EMI) shielding provided by the two cases. Also, both the inner and outer shells will be modified in selected areas for cable routings and heat exchanging equipment for the waste-heat from the electronics. Within the recorder package itself, the printed circuit (PC) boards are probably the next most vulnerable component to be fatigued by vibration, after the recorded tape-head and drive. Typical printed-circuit boards are thin, flexible plates that vibrate easily, often resulting in loose components, cracked solder joints and broken leads. Three methods are available to help the boards survive a severe vibratory environment¹⁰: increase the board's stiffness, shift its natural frequency out of the range of excitation, or damp the board structure. For example, an 8 x 12 inch, 1.2-pound PC board made of 0.06-inch thick epoxy fiber-glass (typical of microprocessor boards) has a fundamental-mode vibratory

Skydyne Company

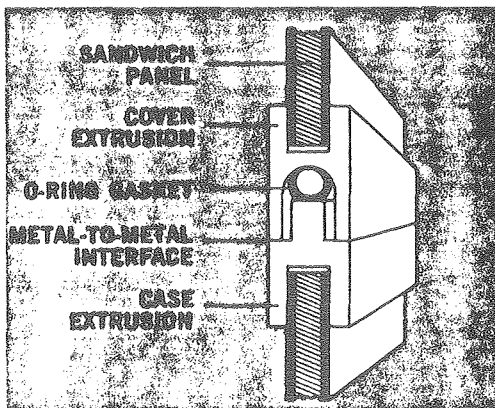
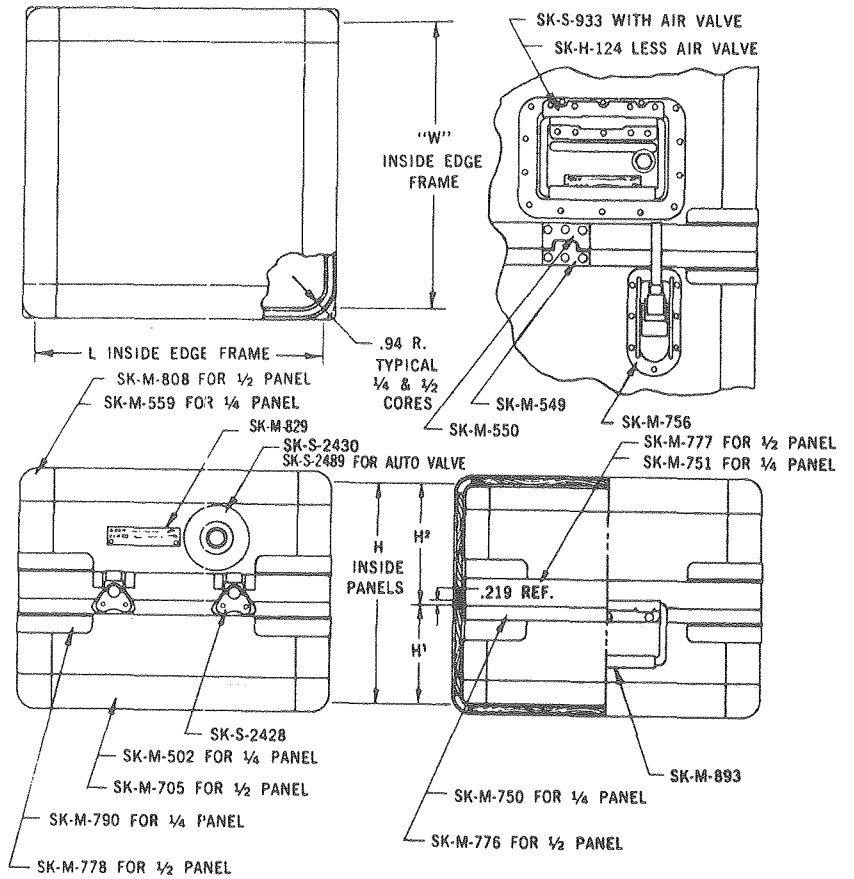
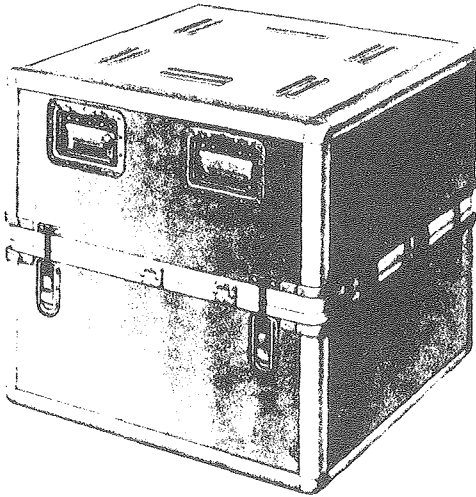

The watertight seal used in all Skydyne closures is more reliable and longer lasting because all pressure and abrasion is made along metal-to-metal surfaces, relieving the wear on the O-ring seal.

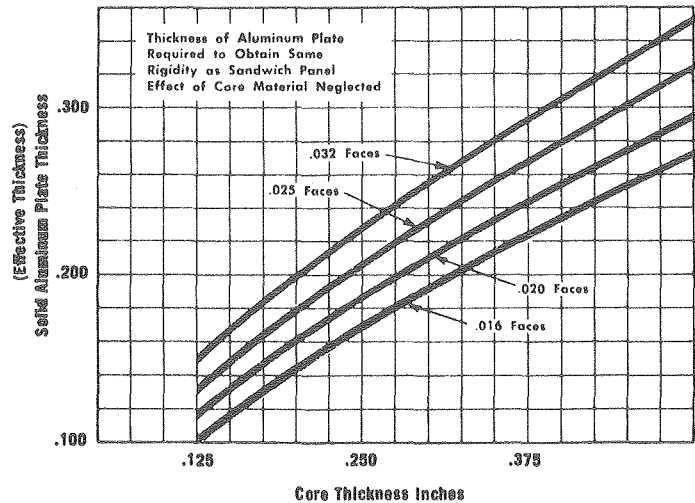

Figure 17. Example of Mil-Std-21200 Enclosure.

frequency of ~ 30 Hz. According to Steinberg,¹⁰ after the board's center displacement exceeds $\sim 0.3\%$ of the board's width, the reliability tends to be reduced. Therefore, 1.5 G at 30 Hz harmonic would cause ~ 0.02 inches S.A. displacement. Neglecting attenuation of the isolator for a conservative design approach and assuming a resonance transmissibility of 5, the board could experience upwards of 0.10 inches (1.3% of width) displacement at the center. By bonding three 0.6 inch-high, 0.06-inch thick longitudinal steel ribs to the board, the natural frequency can be increased 10 times where the input amplitude at 4.2 G is ~ 0.01 inches. At resonance this deflection at the board center could be approximately 0.005 inches, which is a conservative one-fifth of the maximum recommended safe deflection limit. Similar epoxy fiberglass ribs could be used to stiffen the board but the maximum natural frequency gain would be to ~ 150 Hz. In this case the possible mid-board deflection would be closer to the maximum allowable deflection of 0.025 inches.

Since the board stiffening method requires careful installation, fitting and attachment, the third method of displacement attenuation can be done more simply. One approach is to adhere a viscoelastic damping layer and fiberglass constraining layer to form a "damped sandwich" assembly with the circuit board substrate. Resonance amplitude can be reduced up to 90% by this method based on a manufacturer's test data. However, testing is required to insure satisfactory performance for specific board configurations.

4.7 SHOCK AND VIBRATION TESTS

The shock and vibration testing for the locomotive data recorder can be divided into two tasks: component testing and system testing. For the magnetic tape recorder components, the head-to-tape interface and the large microprocessor circuit boards are suspected to be particularly sensitive to vibration.

The tape recorder head and tape drive will be mounted to a vibration table and excited in three mutually perpendicular directions, to simulate their nominal mounted attitude in the locomotive car body. By varying frequency (1-500 Hz) and amplitude it is possible to map the "malfunction" or fragility surface as shown in Figure 18a. For the purposes of this test, failure will be defined as an error in the recording of a known digital signal. Actual component fatigue limits, which would require a lengthy test program to allow extension of the "cycles-to-failure" (time) axis in Figure 18b, is not the goal of this kind of test program. Rather, the recorder's operational characteristics will be evaluated in the frequency-amplitude plane (Figure 18). Some information about life characteristics will also be obtained, since cycles will be accumulated on the equipment during these tests. Particular "resonance valleys" in the fragility plot can be investigated if they are below the amplitude level of the attenuated input vibration.

Component vibration testing for the printed-circuit (PC) boards will serve to insure that the mid-board deflection is below the recommended 0.3% of board width throughout the 1 to 500 Hz excitation spectrum. Testing with the excitation motion (Figure 6) perpendicular to the plane of the PC board will verify if the easily applied damping

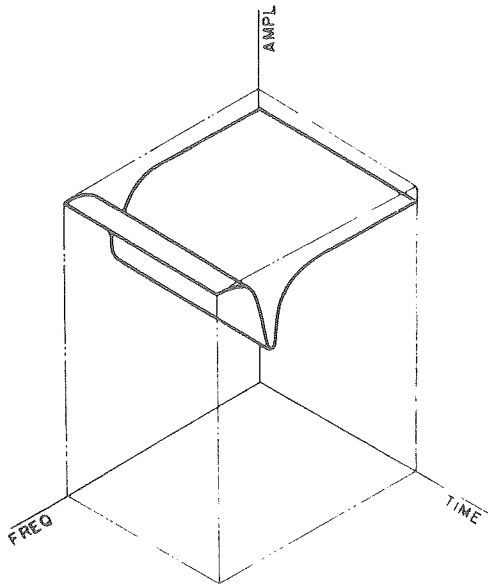

(a) Non time-dependent fragility surface (typical of malfunctions)

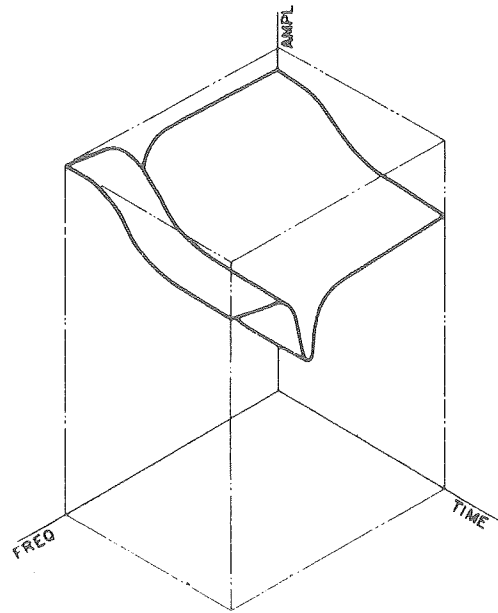

(b) Time-dependent fragility surface (typical of failures)

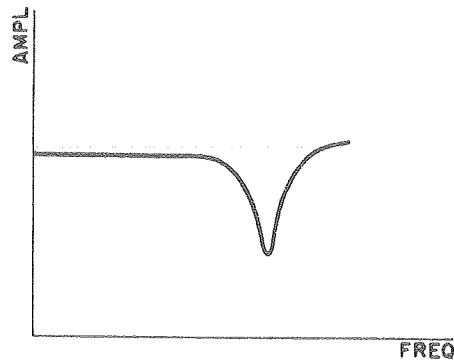

(c) Two-dimensional fragility curve

Figure 18. Fragility Surfaces.

layer will reduce resonance amplitude of the board sufficiently or if the more involved stiffening method will be required. The displacement data will be reduced from the output of a small accelerometer mounted at the center of the board.

For evaluation of the locomotive data recorder system, the complete recorder package mounted on vibration isolators inside the protective outer case will be installed on a shaker table and excited to the frequency and amplitude plot shown in Figure 6. The up-down frequency sweep will be logarithmic over a period of about 18 minutes for a total of 12 complete cycles in each of three mutually perpendicular directions. The recorder will be operating during the test and will be continuously monitored for faults. A tri-axial accelerometer will be mounted to a rigid portion of the suspended mass to evaluate the tri-directional transmissibility of the vibration isolation system. In addition to the steady-state harmonic vibration testing, the isolator system of the recorder system will be subjected to a resonance search per Mil-Std-810C and a random vibration test per the specifications in Figure 19.* A random vibration input, simulating the statistical geometric variation in the railroad right-of-way, will be used to evaluate the effects of exciting simultaneous resonances in the equipment. The shaker that will be used for all the vibration tests will be electro-hydraulic to obtain the low-frequency, high-amplitude response that is typically not attainable with other types of shakers.

Shock-testing for the equipment will be per MIL-Std-810C. The

*High and low frequency ends of the APSD may be respectively ramped up and down based on the requirements of a specific shaker system.

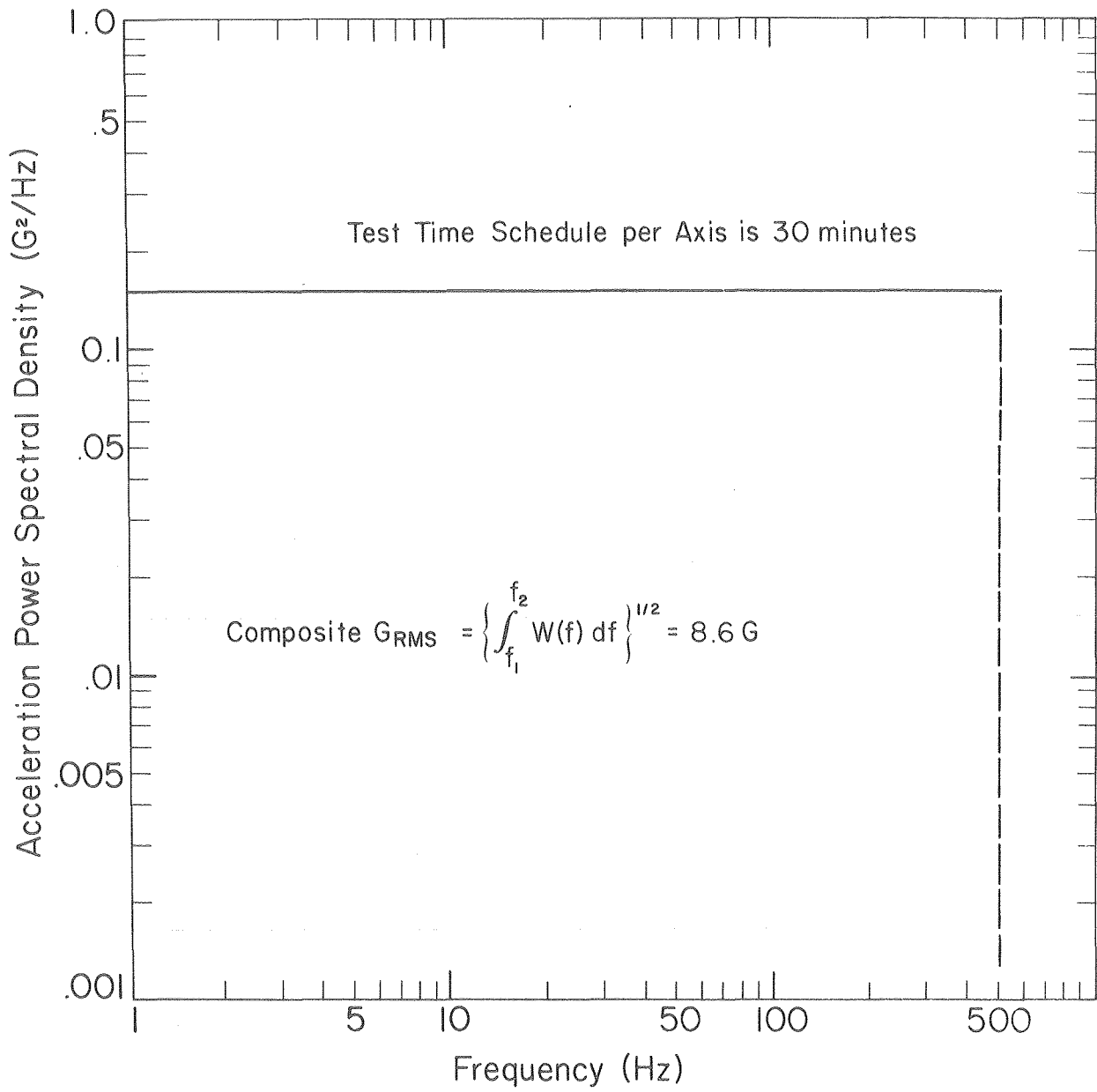

XBL 789-10739

Figure 19. Random Vibration Test Envelope.

0 0 1 0 5 1 0 5 / 9 9

-67-

pulse shape and time interval are shown in Figure 7. During all tests, the equipment will be operating during the tests and monitored for errors in recording.

5. TRANSDUCERS

5.1 AVAILABILITY OF TRANSDUCERS

Table 2 lists the set of 16 measurands that are considered to be part of the basic LDAP system. This list is repeated in Table 4, together with some characteristics of the transducers expected to be used. As shown in the last column of the table, the transducers for most of the applications are stock items, i.e., readily available as a standard commercial product. However, for the measurement of buff/draft forces and fuel flow, it is not expected that commercial transducers will be suitable in terms of the required accuracy of measurement. Several railroad equipment manufacturers have built coupler load cells for measuring buff/draft forces. However, they were custom-made for specific applications such as impact tests.

Therefore, we plan to expend effort during Phase II on designing and fabricating transducers that are suitable for measuring these two quantities. Most of this section discusses in detail the problems associated with this effort.

Table 4. MEASURANDS REQUIRING SPECIAL TRANSDUCERS
TO BE ADDED TO EXISTING LOCOMOTIVE EQUIPMENT

<u>Number</u>	<u>Measurand</u>	<u>Typical Transducer</u>	<u>Availability</u>
A02	Independent Brake Pressure	Strain-Gauge Pressure Transducer	Stock
A03	Trainline Brake Pressure	Strain-Gauge Pressure Transducer	Stock
A04	Buff/Draft Force	Strain-Gauge Load Cell	Custom
A08	Grade	Inclinometer	Stock
A12	Fuel Flow In	Positive-Displacement Flow Meter	Custom
A13	Fuel Flow Out	Positive-Displacement Flow Meter	Custom
A14	Air Temperature	RTD	Stock
A15	Turbocharger Pressure	Strain-Gauge Pressure Transducer	Stock
A16	Engine Temperature	RTD	Stock

5.2 GENERAL COMMENTS ON TRANSDUCERS

The measurement transducer is the portion of the data acquisition system that transforms the quantity to be measured (measurand) into another quantity more easily measured. For example, a thermocouple inserted in a moving gas stream will cause the transformation (by heat transfer) of the gas temperature into a related temperature of the thermocouple junction; the temperature of the junction is transformed into an electrical output in the form of voltage or current, depending on the instrumentation conditions. In general, all transducers convert input energy into output energy.

The operation of each measurement transducer can be divided into

five sub-topics:

1. Measurand(s)
 - a. Primary (usually a single parameter)
 - b. Extraneous (undesired inputs, usually many)
2. Sensor
3. Transduction element (including any signal conditioning internal to the transducer)
4. Excitation
5. Output

With these topics defined, the single difference between the two basic types of transducers, self-generating and non-self-generating, can be distinguished; excitation is required for non-self-generating transducers. An example of a non-self-generating transducer would be a strain-gauge pressure transducer with the following typical operational parameters:

1. Measurand(s)
 - a. Primary measurand - Pressure
 - b. Extraneous measurands - Temperature, moisture, mechanical vibration
2. Sensor - Metal diaphragm flexure
3. Transduction element -Foil strain gauges
4. Excitation - Voltage/current
5. Output - Voltage/current

The previously mentioned thermocouple transducer is a self-generating transducer since the transduction element/sensor (bimetallic junction) does not require an excitation to produce an output voltage/current.

When evaluating the possible combinations of transducer parameters -- i.e., the kinds of energy available for measurands, excitations, and outputs -- the numbers are large. Starting with just eight classes of

energy (acoustical, chemical, electrical, magnetic, mechanical, nuclear, optical, and thermal) over 500 different kinds of transducers can be hypothesized. However, for the locomotive data acquisition package, the basic measurands will be initially restricted to mechanical, electrical and thermal. Also, since the recording system is based on electronics, all the transducers will have electrical outputs, in contrast, for example, to the mechanical (pressure) output of a capillary-tube-type temperature transducer. Furthermore, for non-self-generating transducers, excitation will be electrical in most cases. Table 5 summarizes transducer combinations of possible application to LDAP.

5.3 TRANSDUCERS, BUFF-DRAFT FORCES

In terms of transducer terminology, buff-draft force transduction can be considered a mechanical input with electrical excitation (if required) and output. Self-generating transducers, such as piezoelectric load cells, do not need excitation. However, they would be difficult to interface with a railroad coupler, since they are usually installed in series with the load-carrying member. In contrast, passive or non-self-generating transducers are typically installed in parallel with the load-carrying member and therefore are less difficult to install on existing hardware configurations. Thus the following discussion will be directed toward non-self-generating transducer systems involving either the mechanoresistive, mechano-capacitive, or variable inductance effects.

Measurement of force can be made by the measurement of relative displacement of points on a surface or between two surfaces. An example,

for historical reasons, of the latter method is the floating-piston hydraulic load cell used on older railroad dynamometer cars. The piston does not actually contact a cylinder wall (so that seal friction can be minimized), but instead seals against a thin metal diaphragm (reinforced on the edges) that allows a small piston movement. When a force acts on the piston, the resulting oil pressure is transmitted to a pressure-sensing system that, on older equipment, is often a Bourdon-tube actuated oscillographic recorder. Piston movement is ≈ 0.002 inches at full scale and accuracy is $\approx \pm 1500$ pounds (250 kips full-scale) with ≈ 100 -pound zero shift per degree ($^{\circ}\text{F}$) temperature change.¹¹ The hydraulic system could be interfaced with an electronic data acquisition system, but the basic mechanical-hydraulic transducer itself would be costly and would need to be dedicated to one specific piece of rolling stock. Most modern load cells are mechanoresistive or strain-gauge-based transducing elements. Since they sense relative displacement in stressed materials, any elastic member can be used as a "sensor"; the strain gauge is attached to the surface of the member (i.e., parallel to the load path) rather than in series as is the case with the hydraulic or piezoelectric load cells. Variable inductive and mechano-capacitive effects also can be used to detect the small stress-caused deflections in materials with the variable inductive principle probably having the most promise for use in LDAP.

Before the construction details of a strain-gauge based, buff-draft force transducer are outlined, the goals for overall performance will be presented. The full scale (FS) load of the LDAP buff-draft force transducer will be 250,000 pounds. It would be desirable to achieve

a transducer of this capacity with a $\pm 1\%$ FS system accuracy and $\pm 5\%$ FS zero-balance error. While it is possible to build load cells to $\pm 0.15\%$ FS system accuracy and $\pm 1\%$ FS zero-balance error, this would be an unrealistic requirement for LDAP, considering the ambient temperature span between -40° and 140°F and the harsh operating environment. Note that the $\pm 5\%$ FS zero-balance may seem worse than it actually is; a zero reference indicator similar to the slack-action indicator (i.e., a way to detect transitions between buff and draft) discussed in one reference,¹² would provide a periodic zero reference to check the load cell "0". Of course, if there is no transition between buff and draft during a large temperature change, this method cannot compensate for the resulting zero shift.

Nearly all strain gauge force transducers consist of a beam or axial tension-compression elements (flexure) and a strain gauge network. All force transducers actually are multi-component sensors, but an output usually is desired from one axis only. Figure 20 shows a locomotive coupler with several different force and moment combinations acting on it. It is the task of the transducer flexure (assumed to be the shank) and the strain gauge combination to be sensitive only to axial tension and compression and, of course, to serve as a drawbar to reliably carry the train load. The most common bridge arrangement for a column load cell flexure is the so-called "2 2/3 active arm" bridge configuration with two legs of the bridge oriented in the axial direction and two in the transverse or Poisson direction. With 1150 to 2000 microstrain existing in such a column flexure at full scale, the full scale bridge output can be expected to be ~ 2 to 2.7 mV output per volt of excitation

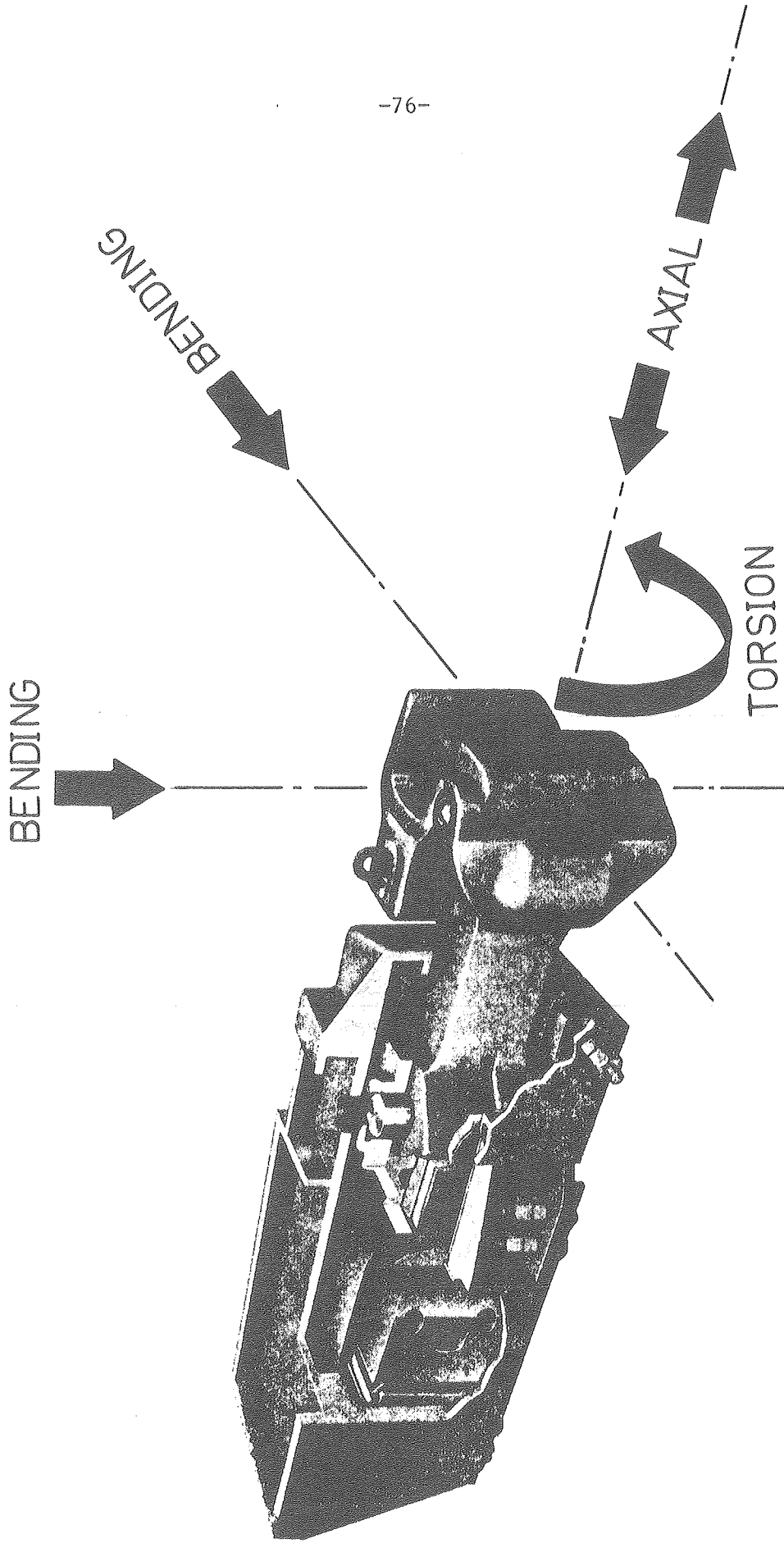

Figure 20. Four Basic Coupler Loading Modes.

(for gauge factors of 2.0). This configuration of strain gauges can be connected in the bridge to: 1) minimize the sensitivity of the system to bending and torsion inputs and, 2) assuming that the flexure is uniform in temperature, make the output nominally independent of temperature-induced displacements. It is possible, by using beam elements in a thrust-sensitive load cell flexure, to obtain a "4 active arm" bridge and to therefore obtain up to 4 mV output per volt of excitation at 2000 microstrain; however, this kind of specially designed flexure probably would not be well suited to the load carrying task of a coupler.

With 2000 microstrain established as the upper-limit full scale strain for the load cell flexure and for $\pm 1\%$ FS system accuracy (not including electronics) requirements, a strain value in the 10 microstrain range is significant in defining the performance of the load cell. Therefore, material responses leading to spurious strains on the order of 10 microstrain must be addressed in the load cell design. Material-related effects such as micro-yielding, anelastic (recoverable) deformations, dimensional instability, creep, and environmental responses all can provide undesired strains in the 10 microstrain range. To minimize the above problems, careful control of the flexure metallurgy is required, as well as an upper stress limit of $\sim 30\%$ of yield.¹² By using the existing coupler shank as a column-type transducer flexure, the full-scale strain output at the 250,000-pound design load would be ~ 420 microstrain (based on a 20 in.² shank area). This calculated value is in good agreement with the data (shown on Figure 21) from a report by Anderson and Cramer¹³ on the stiffness of coupler shanks conforming

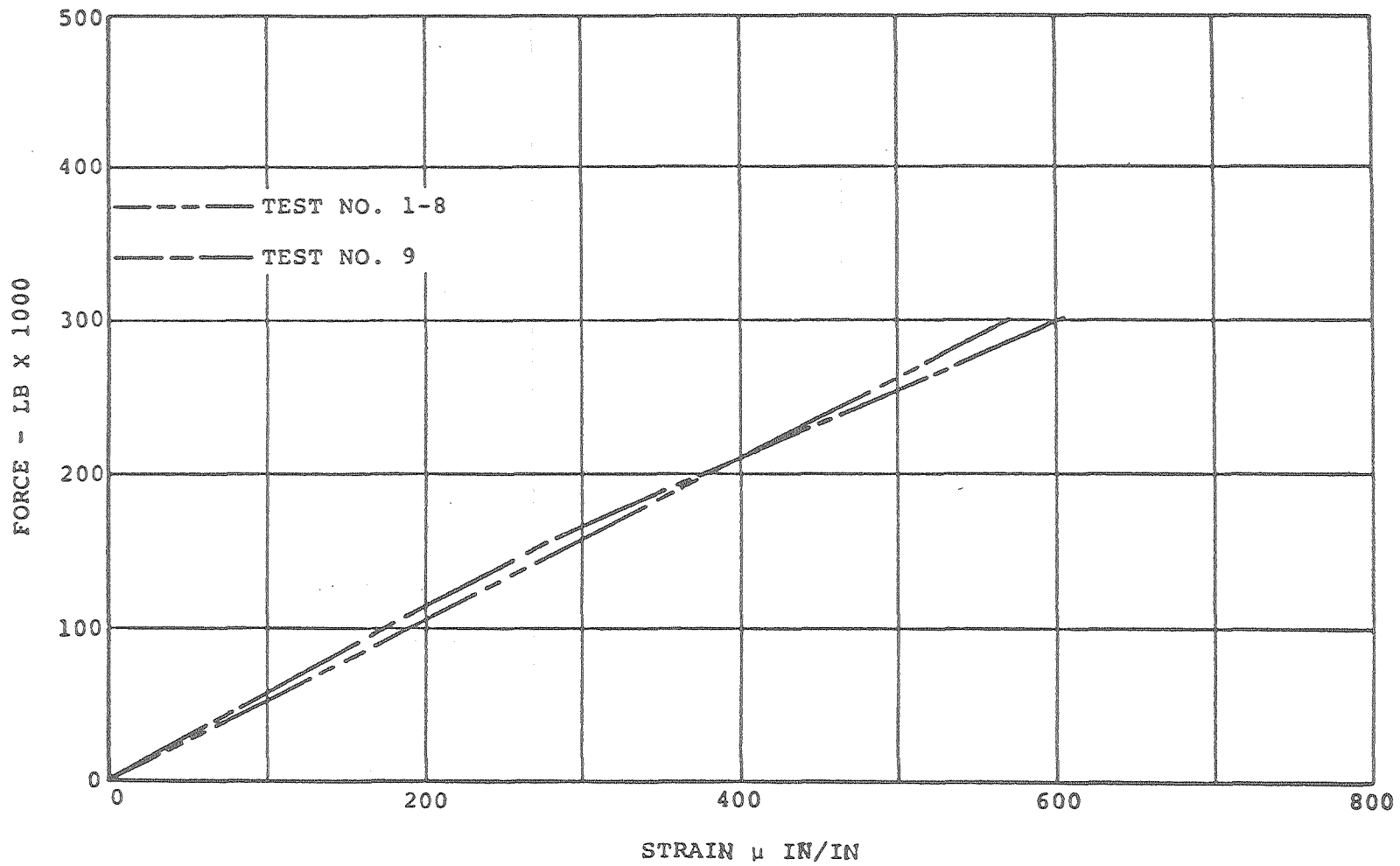

Figure 21. Locomotive Coupler Shank Strain.

to specifications of American Association of Railroads (AAR). This low, full-scale strain level in the coupler shank indicates the coupler is a conservative design from the standpoint of pulling trains but has only 25% of the full-scale strain level output desirable for a well-designed transducer flexure. It could be possible to design ultra-stable signal processing electronics to deal with the 0.6 mV/V FS signal from such a "stiff" flexure, but spurious strains (introduced from the micro-mechanical aspects of the flexure material) of 1 microstrain magnitude would be significant for maintaining $\pm 1\%$ FS overall accuracy. The locomotive drawbar material is not classified as an ultraprecision, transducer-flexure material, so that a transducer made directly by using the coupler shank as a flexure would probably tend to be a $\pm 5\%$ FS device.

Another approach to improve bridge output and still allow direct use of the coupler casting as a flexure would be to locate: 1) symmetrical regions on the coupler body that are more highly stressed than those of the shank and/or 2) elements of the casting undergoing bending (allows a 4 active arm bridge without constructing a ring or other type of special flexure). Brittle lacquer or photoelastic coatings would be useful in mapping the strain field on a coupler loaded in several modes (tension, compression, bending, and torsion) so that relatively highly strained regions, that would still allow loading-mode separation by proper placement of strain gauges, could be located. Areas of high stress gradients around sharp corners would not be desirable gauge locations because of difficulty of installing transducer-sized strain gauges on sharp discontinuities and the micro-yielding of the material that could occur at such a stress

concentrations. Artificial addition of stress concentrations in the coupler shank by drilling holes, for example, could be used to boost the full-scale transducer output in the ~ 1 mV/V range. However, analysis would be required to insure protection against drawbar ultimate failure or yield. High output semiconductor strain gauges could also be used, but they introduce a whole new set of temperature-related problems.

Probably the best approach to obtain a reasonable transducer output would be to build a special drawbar flexure that would be strained high enough to give 2 to 3 mV/V FS output with conventional resistance strain gauges, but not fail in the task of pulling the train or when experiencing hard couplings. Two thousand microstrain in steel translates to $\sim 60,000$ lb/in.² stress and, in aluminum, $\sim 20,000$ lb/in.² With the maximum-stress requirement of 30% yield at full scale, a steel having a 200,000 lb/in.² yield stress would be required, which is slightly over the upper limit obtainable with 4340 alloy steel or 17-4 PH stainless steel tempered in the 800°F range (to avoid "brittleness"). For similar stress requirements in aluminum, certain heat treatments of 2024 alloy steel will nominally meet the specification.

Since 2,000 microstrain specification tends to crowd the upper limits of material performance (particularly in a large cross section), a 1,500 microstrain full-scale strain limit will give a more conservative design for any of the three materials mentioned above and still provide ~ 2 mV/V output at full scale for a "2 2/3 active arm bridge." If steel is used for the 250,000-pound flexure, ~ 5.6 in.² would be needed

for the column and if aluminum is used, $\approx 16.8 \text{ in.}^2$ is required. Of course, more sophisticated flexures can be used to increase the bridge output into the 3 mV/V range, but the need for the flexure to also reliably pull a train and to easily mount to a locomotive pilot structure makes the simple column flexure more attractive.

It is clear that design of a high output, structurally integral load-cell transducer flexure is not a trivial problem. However, even after the flexure design is optimized from the standpoint of elasticity, a number of other problems relating to the strain gauges themselves and non-mechanically caused strains (particularly temperature) must be considered.

After all of the known best practices of strain gauge selection, installation, wiring, and environmental-proofing have been carefully adhered to, two principal temperature-change effects on the strain-gauge bridge circuit remain to be dealt with: shift of bridge zero-balance point and change in span (voltage per pound). Zero shift is caused by unsymmetrical, thermally produced resistance changes within the bridge circuit. Even after careful symmetrical wiring and gauge placement, zero shift with temperature will occur because no two strain gauges exhibit exactly the same temperature-induced apparent strain characteristics. To compensate for this shift, an opposing temperature-dependent resistance imbalance can be placed in the bridge circuit. Span changes with temperature because of two distinct effects. First, the elastic modulus of the spring element decreases as the temperature increases (causing a greater bridge output for a given load), and second, the gauge factor changes with temperature. If it is assumed

that output increases with temperature, a resistor with a positive thermal coefficient can be introduced into a bridge power supply; therefore, as the temperature rises, the compensating resistor reduces the voltage input to the bridge and the span change is minimized. Additional compensating resistors can be added to establish an initial zero balance (for a given temperature) and an initial span. Figure 22 pictorially summarizes a possible configuration for a "2 2/3 active arm" strain-gauge-based buff-draft force transducer.

Initial calibration of the transducer should be done on a dead-weight calibrator (NBS traceable) and field calibration checks can be accomplished with a commercial, precision-class, load cell. Dead weight calibration capability and load cells are available in the 250,000-pound range from BLH Electronics in Waltham, Massachusetts. The frequency and amplitude response of the transducing system (including load cell, draft gear, and electronics) can be evaluated on a tensile testing machine that has programmable amplitude, wave shape, and frequency capability. Dynamic testing (step function response) is also useful for verifying the overall time constant, natural frequency, ringing period, damping ratio, rise time, response time, and overshoot of the transducing system. Further testing could be performed to verify the ability of the flexure and strain gauges to cancel bending and torsional inputs.

5.4 INSTRUMENT TRANSDUCERS FOR LDAP - FUEL FLOW

The measurement of locomotive fuel consumption with reasonable (e.g., $\pm 1\%$) accuracy has some special requirements not shared by other

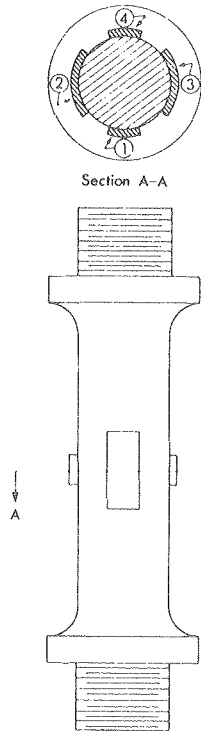

(a) Basic column load cell bridge configuration (without averaging networks shown).

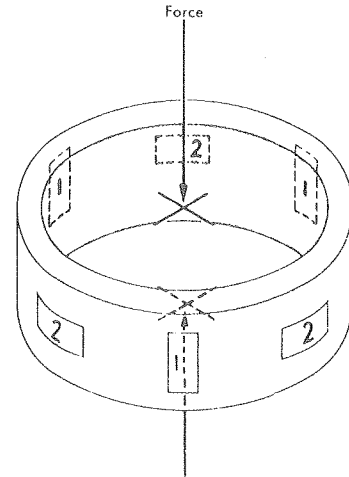
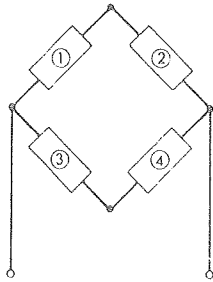

(b) Possible strain averaging configuration for a column load (axial gauges are connected in series and occupy bridge position #1 in figure at left and transverse gauges are connected in series and occupy bridge position #2; also applies to positions 4 and 3, respectively).

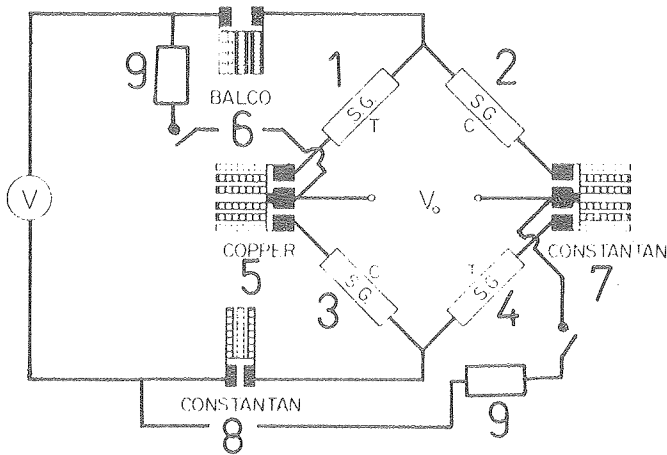

- 1 - 4 Strain Gauge Networks
- 5 Zero Shift Compensation Resistor
- 6 Span Compensation Resistor
- 7 Initial Zero Balance Resistor
- 8 Initial Span Adjust Resistor
- 9 Shunt Calibration Resistors (Optional)

(c) Compensation resistors

Figure 22. Force Transducer Scheme.

liquid flow measurement tasks. These include the requirements to measure fuel flow over a large dynamic range ($\approx 50:1$) and the requirement to measure both input and return fuel flows to the engine, since the actual fuel consumed is the difference between the two flows. At no-load, idle conditions, where the fuel consumption is low (≈ 0.1 gal/min or ≈ 0.7 lbm/min), the two flow meters will nearly read the same. In this case, the typical $\pm 1\%$ FS accuracy for a single meter may obscure the true flow, which is obtained by subtracting two readings. Several approaches are possible to solve this difficulty:

- 1) use high accuracy (i.e., better than $\pm 0.5\%$ of reading), large-range meters;
- 2) use two high accuracy meters to cover the large range in two steps;
- 3) use a single, high accuracy meter placed so as to measure only the fuel consumed by the injectors.

Before the relative benefits of these options are discussed, some of the selection criteria for a locomotive fuel flow meter system will be outlined.

During the process of designing a system for measuring locomotive fuel flow accurately, some important things should be considered. First, the characteristics, capabilities and reliabilities of the various flow meters that are available on the market should be carefully surveyed. Secondly, the effects on the accuracy of measurement due to the manner in which the meter is installed should be determined. Thirdly, the influence on the measurement of the conditions of the fluid itself -- temperature, density, viscosity -- must be understood. It should also be decided whether the rate of flow or the total volume of fuel consumed

should be measured directly. Finally, the relationship between volume of fluid and mass of fluid must be considered.

With regard to the last point, mass flow is usually the quantity of interest, since fuel energy is most accurately determined for mass-related properties of the fuel. However, for practical reasons, volume is often the directly measured quantity, so that the mass-related information must be reduced from the volume data. There is an accompanying accuracy penalty because of imperfect knowledge of temperature, density, and the like. If the fuel mass consumed over a certain time interval is the basic parameter of interest, there is no more accurate method of measurement than direct weighing before and after the interval. Of course, "direct weighing" is not trivial to perform and, more importantly, makes it difficult to derive any time-history of the flow. The time history is easily obtained if flow rate is the quantity directly measured; the integration of flow rate to obtain volume (or mass) can involve additional error.

Pressure difference devices, such as orifice-plate meters, are by far the most common industrial flowmeters, but these devices are limited in performance. Positive-displacement and turbine meters can provide $\pm 0.2\%$ FS accuracy in flow rate. This type of meter, however, is very sensitive to contamination in the fluid, its installed location in the piping system, and also has moving parts to wear. Despite these drawbacks, the "positive displacement" class of flow meter is probably best suited to the dual rate and quantity needs of LDAP.

The true positive displacement flow meter (an example is shown in Figure 23a) is actually a positive displacement fluid motor in which

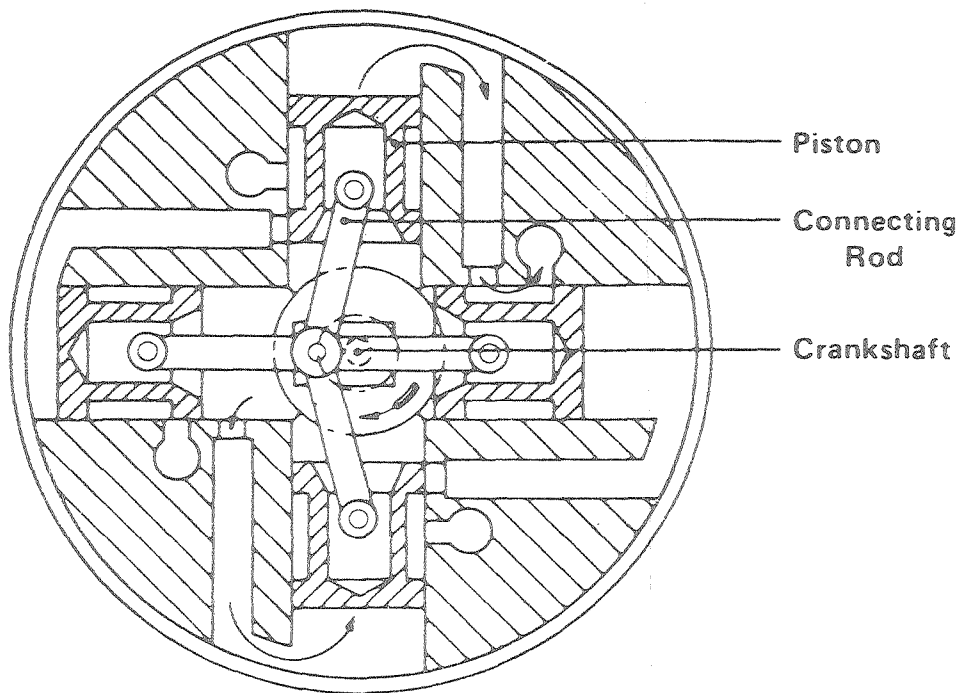

(a) Positive displacement piston type

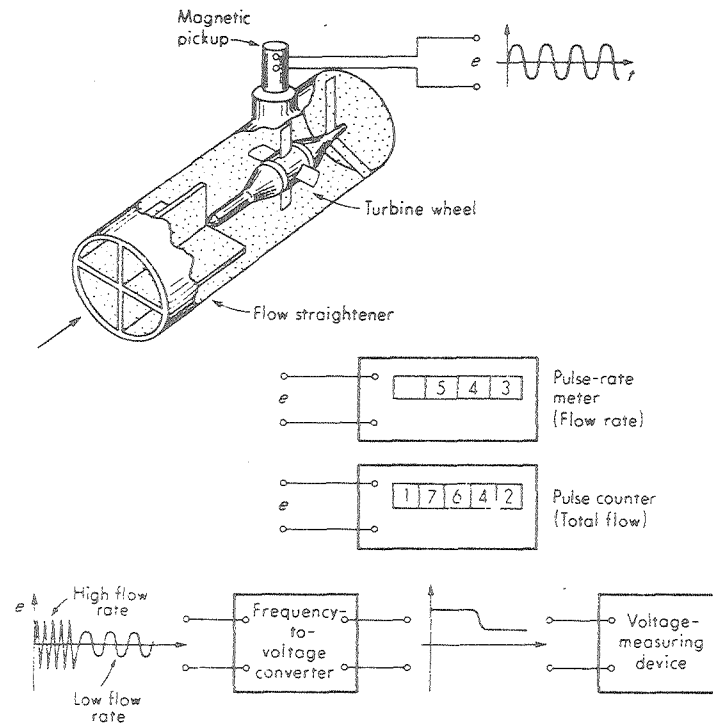

(b) Turbine type

Figure 23. Two Classes of Flowmeters for Use for Locomotive Fuel Flow Measurements.

friction and inertia have been reduced to a minimum. The flow of a fluid through volume chambers of defined size causes rotation of an output shaft. A mechanical or electronic counter records the total number of rotations, which is proportional to the total flow. Since the volume is measured in discrete quantities, the flow-rate resolution of a positive displacement meter is limited and transients in flow can be masked.

The turbine meter, with its lower mass and friction, can be useful for both rate and quantity. The rotary speed of a turbine wheel placed in a pipe containing a flowing fluid depends on the flow rate of the fluid. By reducing bearing friction and other losses to a minimum, one can design a turbine whose speed varies linearly with flow rate. The turbine speed can be sensed with great accuracy by counting the rate at which turbine blades pass a given point. A magnetic proximity pickup can be used to produce a voltage pulse as each blade passes. These pulses can be fed to an electronic pulse-rate meter to measure flow rate. The total flow is obtained by accumulating the total number of pulses during a timed interval. If an analog signal is desired, the pulses can be fed to a frequency-to-voltage converter. Figure 23b shows a typical turbine flow meter with several data-extraction options. Commercial turbine meters are available with full-scale flow rates ranging from ≈ 0.01 to 30,000 gallons-per-minute for liquids, and typical output voltages are in the order of 10 mV rms at minimum flow and 100 mV rms at maximum flow. Turbine flow meters, in contrast to positive displacement flow meters, can follow flow transients with reasonable accuracy since their fluid/mechanical time constant is of

the order of ~ 2 to 10 msec.¹⁴

As previously mentioned, in the many possible applications of LDAP involving fuel-flow measurement, the mass flow rate is actually more significant than volume flow rate. Two general approaches are used to measure mass flow rate. One involves the use of a volume flow meter, some means of density measurement, and a computer to compute the mass flow rate. The other, more basic approach, is to use a flow meter design philosophy that is inherently sensitive to mass flow rate. Figure 24a shows a schematic of a "computed-mass-flow" measurement system (for orifice-plate and turbine meter types). Figure 24b is an example of a direct mass-flow rate meter using the "moment-of-momentum law" of turbomachines. Both computed and direct mass flow systems are applicable to LDAP -- system reliability being a basic consideration for the selection of one over the other.

As mentioned above, the problem of the large dynamic range of flows needs to be addressed. Of the three options discussed earlier, the first approach (a single high-accuracy meter) seems the most reasonable. Typical flow rates for SW-1500 and SD-45 locomotives have been quoted as: minimum flow (idle) -- ~ 0.07 gal/min (0.5 lbm/min); maximum flow (run-8) -- ~ 3.3 gal/min. (24 lbm/min).¹⁵ During a typical daily operation schedule for an EMD SD-40 locomotive, about 50% of the time is spent idling, 15% in run-8, and the remaining 35% of the time evenly divided among the other throttle settings.¹⁵ Because of the large amount of time spent in idle at low fuel flows, significant errors in total fuel quantity are possible if the flow meter is selected only for its performance at higher flows. Positive displacement flow meters

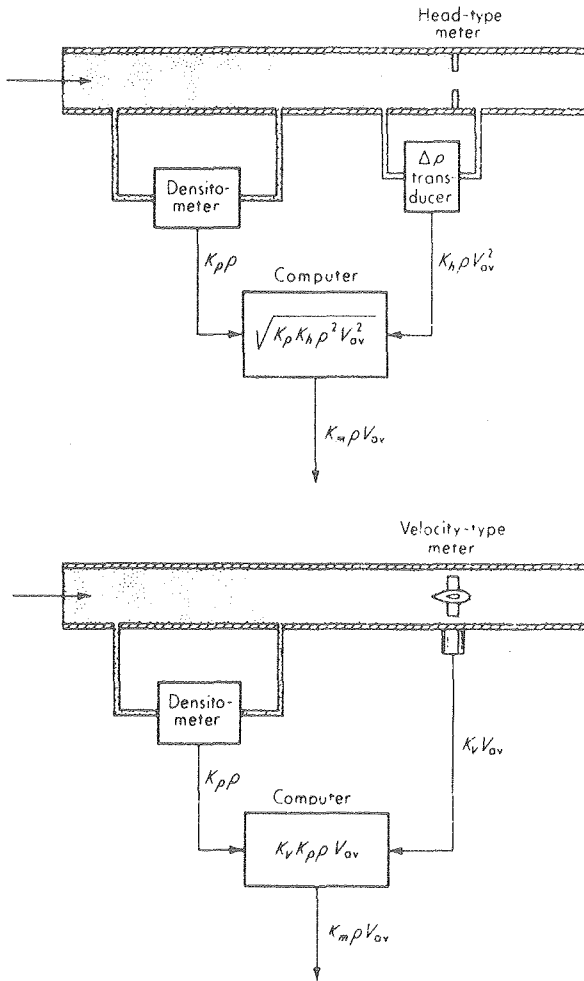

(a) Method for computing mass flow rate from volumetric flow rate

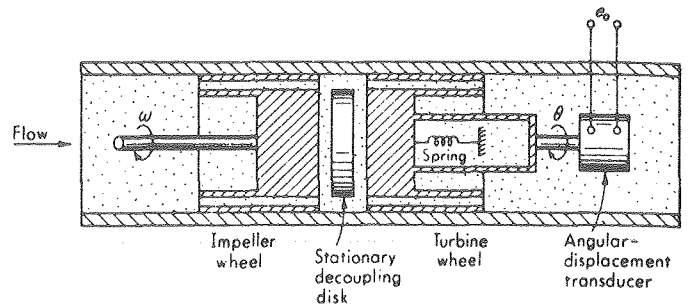

(b) Direct measurement of mass flow rate

Figure 24. Two Methods for Obtaining Mass Flow Rate.

have the best capability of covering the 50:1 range while still maintaining accuracy in total flow indication. Typical positive-displacement flow meters that are designed specifically for hydrocarbon fuel-flow measurements can, in fact, cover a flow range of 500:1 (for 5 centipoise viscosity diesel fuel) with $\pm 0.5\%$ overall accuracy. Of course, to obtain this accuracy, the installation has to be carefully done to address the problems of air entrapment in the fuel, the large temperature change ($\sim 20^\circ\text{-}40^\circ\text{F}$) between incoming and outgoing fuel (typical of locomotives using unit-type fuel injectors that bypass a large quantity of fuel -- $\sim 98\%$ at idle, for example), and the influence the flow measurement device has on the fuel system. A positive displacement flow measuring system should have a bypass so that if the pressure drop across the flow is excessive (as would be the case for a seized piston), fuel flow to the engine will not be interrupted. To make the translation between volume and mass flows, a temperature sensing probe can be installed at the inlet of the flow meter to allow mass-flow compensation for the flow transducer.

Calibration will be necessary for any flow sensing system used on LDAP. Flow-rate calibration depends on standards of volume (length) and time, or mass and time. Primary calibration is, in general, based on the establishment of steady flow through the flow meter and subsequent measurement of the volume or mass of fluid that passes through in an accurately timed interval. If steady flow exists, the volume or mass flow rate may be inferred from such a procedure. Of course, significant deviations of the conditions of use from those at calibration will invalidate the calibration. Possible sources of error in an

installed flow meter's calibration include variations in fluid properties (density, viscosity, and temperature), orientation of the meter, pressure level, and, in particular, flow disturbances (such as elbows, tees, valves) upstream and downstream of the meter.

There are two basic types of primary liquid flow calibrators in present use:

I. Mass-time type

- A. Static-weigh method
- B. Dynamic-weigh method

II. Volume-time type

- A. Level-sensing (standpipe method)
- B. Positive-displacement method

Of the mass-time techniques, the dynamic-weigh method is preferred since a static-weigh flow calibration program can be very time consuming. However, gravimetric-calibration, while permitting high accuracy, has some basic drawbacks in portability, variations of the weigh system's dynamic response between initial and final balance, and problems in handling volatile, flammable hydrocarbon liquids. For these reasons, sealed volumetric systems, particularly those based on the positive displacement technique, are very useful for calibrating flow transducer systems used for hydrocarbon liquids. One such commercial system uses a gas-pressurized free piston to displace a quantity of test liquid through the flow transducer under test. The piston's linear displacement and the flow transducer's output are very precisely measured and electronically processed to generate a calibration curve. Small, field-sized positive displacement units are available as secondary standards to cover low-flow ranges in the 0.01 to 10 gallons per minute range,

to \approx 0.1-0.2% accuracy.

Environmental considerations are also important in determining the application of a flow meter's calibration data. In Robertson and Baumgarten,¹⁶ different flow meters, including a four-orifice, four-piston, positive displacement-pump, and turbine flow meter types, were tested in a laboratory-simulated automotive environment. Figure 25a, which is a graph from Robertson and Baumgarten, demonstrates an apparent resonance effect at 16 Hz resulting from vertical harmonic vibration acting on a piston flow meter. Figure 25b is a blowup of the suspected resonance area. Figures 26a and 26b are respectively plots of a resonance dwell in the vertical and horizontal directions. These data clearly indicate that vibration can influence the output of a piston-type positive displacement flow meter; the other three kinds of meters tested in Robertson and Baumgarten¹⁶ suffered similar degradation of performance at suspected resonance points when excited by mechanical vibration. The mounting scheme in the locomotive engine compartment will be the major control on vibration transmission to the flow meter.

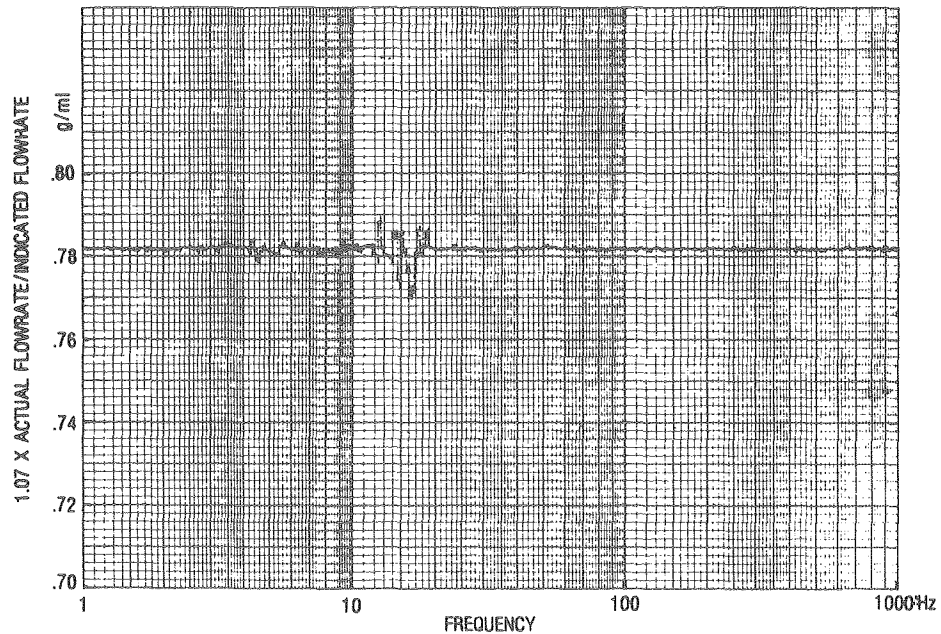

(a) Vertical vibration test. The peak-to-peak displacement is 2.54 cm from 1 to 5.4 Hz, and the peak acceleration is $1.5 \times 980 \text{ cm/s}^2$ from 5.4 to 1000 Hz. The time required for sweeping from 1 to 1000 Hz is 10 minutes. The flowrate ratio times 1.07 is averaged over 107 ml. The factor 1.07 occurs because the flowmeter on the average has one pulse per 1.07 ml indicated on its digital display, and the pulses are used to obtain the vertical display. The actual flowrate is 10 g/s, the indicated flowrate is in ml/s, and the average density is 0.73 g/ml, so the ordinate should be 0.78 g/ml.

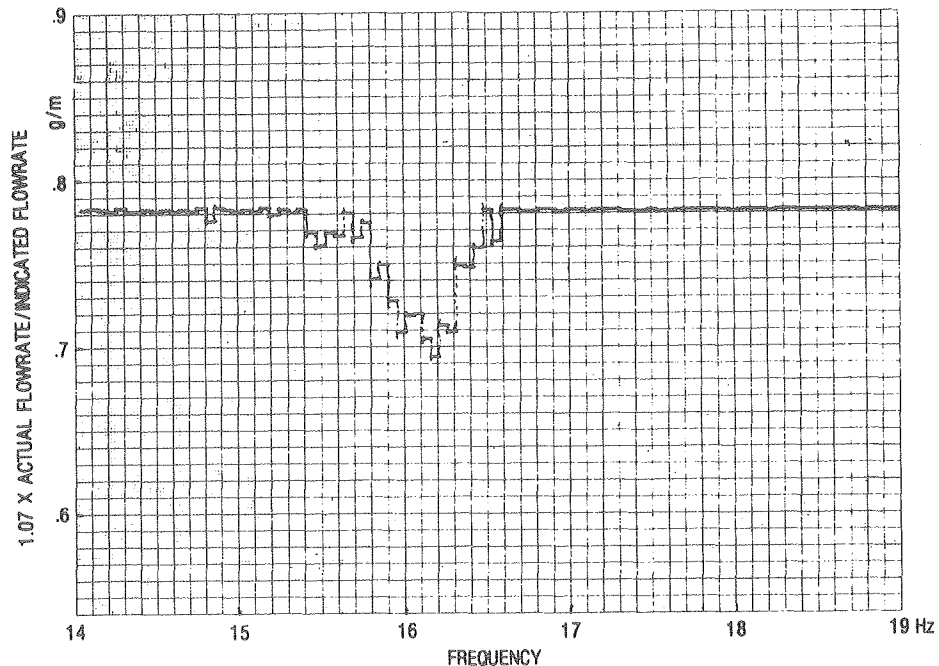

(b) Vertical vibration test. The conditions are the same as in (a) except the frequency is swept from 14 to 19 Hz in 10 minutes, and the ratio times 1.07 is averaged over 10.7 ml. The effect is more clearly shown here than in (a).

Figure 25. Vertical Vibration Tests of the Four-Piston Flowmeter.

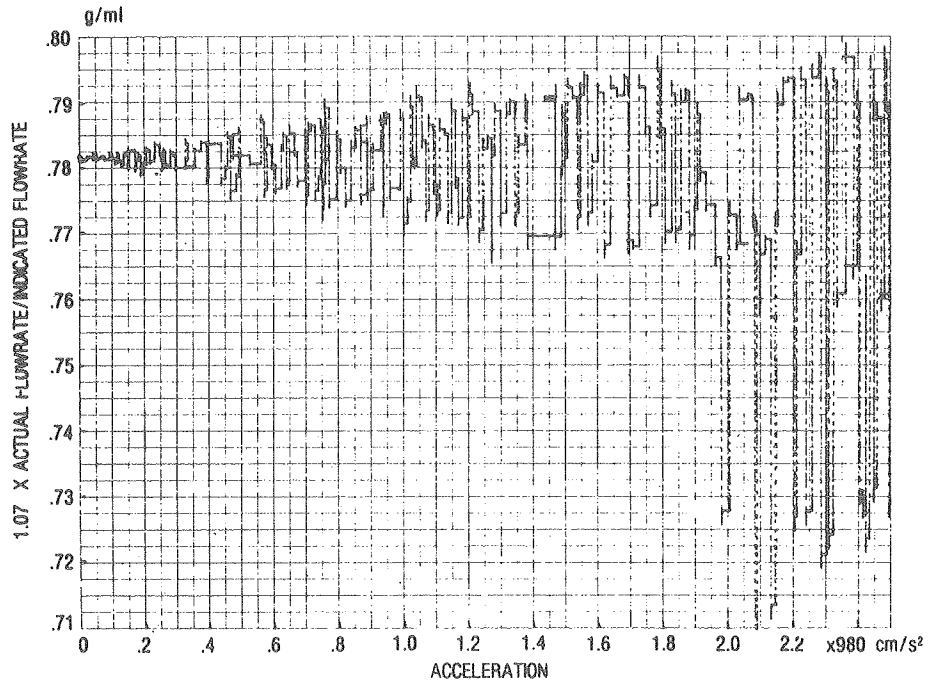

(a) Vertical vibration test. The conditions are the same as in Fig. 25b except the frequency is fixed at 16.1 Hz and the peak acceleration is increased smoothly over a 10 minute interval. The wide excursions in the graph above $2 \times 980 \text{ cm/s}^2$ are due to the ratio exceeding the maximum range of the digital-to-analog converter. Below $2 \times 980 \text{ cm/s}^2$ the effect is clearly shown to increase with increasing acceleration.

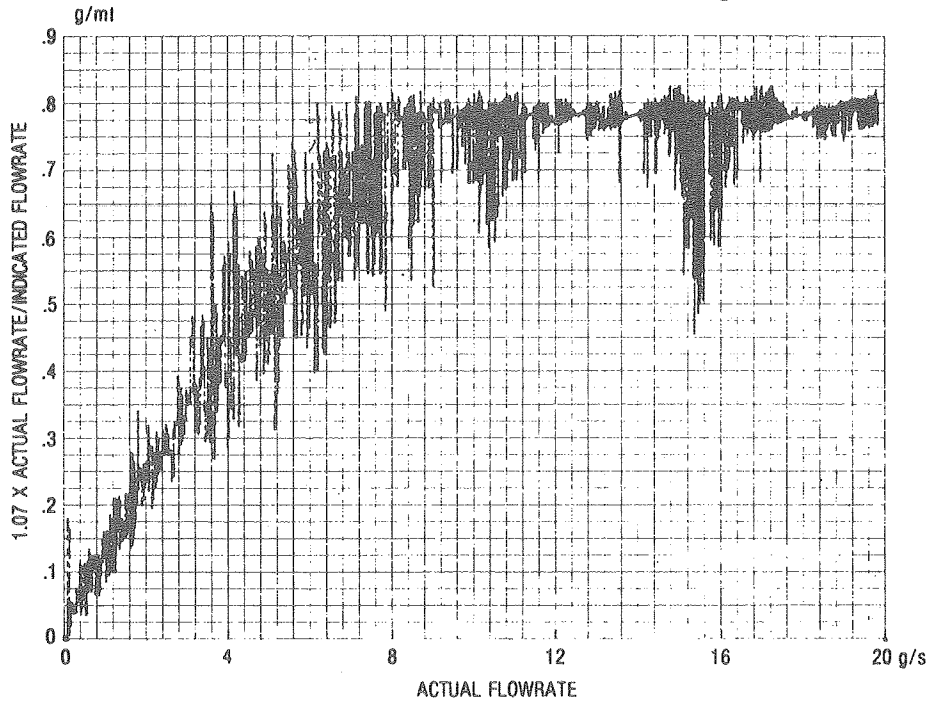

(b) Horizontal vibration test. The conditions are similar to those in Fig. 25b except the frequency is fixed at 16.0 Hz and the flowrate is increases smoothly over a 20 minute interval.

Figure 26. Vertical and Horizontal Vibration Tests of the Four-Piston Flowmeter.

6. DATA PROCESSING CONSIDERATIONS

6.1 INTRODUCTION

The basic purpose of the LDAP system is to acquire data about diesel-electric locomotive conditions and to make the resulting information available in a form that people can assimilate. The value of the total project, therefore, hinges on the success in making the information available in a meaningful form. In this section we review some of the processes involved in the flow of information from initial acquisition to ultimate use. This will include discussion of sources and destinations of data and control; the major processing steps, both hardware and software; and the means and format by which processed information is made available to the user.

The intention is that all data processing will be handled automatically, with a minimum of human intervention, and with previously prepared computer programs. For this to be successful the various functional parts of the total system must be properly integrated and the information be properly communicated from one function to the next. This section discusses some of these considerations.

6.2 INFORMATION FLOW AND PROCESSING FUNCTIONS

Our discussion of information flow will, in broad terms, include:

- a. the points at which data comes into the system and the content and significance of each of these data sources;
- b. the points at which the user may interact with the system to control the flow of information or its processing;
- c. comments on the hardware and software facilities needed to process the data as it flows through the system.

Figure 27 depicts, in block diagram form, the major functions involved in the flow of information through the system. In an actual implementation, the hardware facilities used to effect the functions can take different forms according to the processing requirements in a particular measurement project, or according to the facilities that are available at particular locations. In some instances, for example, access to a computer facility of adequate size may be easily available. In other cases, the computer facility may be remotely located so that data must be transmitted over telephone lines to the computer. Functionally, the processing steps in either case may be very similar, although the "partitioning" of the physical hardware may be quite different.

Also, we are discussing a system that can be used for a wide variety of measurement applications. Not all functional facilities will be required for all applications.

6.3 SOURCES OF DATA

As shown in Figure 27, information in the form of data or control may enter the system at several points. The information sources are categorized into three groups in Table 6.

- a. In the first group are the sensors and transducers located on the locomotive. The sensors and transducers are, of course, the primary source of the measurement or performance information that is to be recorded. In some instances, however, they may also be used to obtain information on their own characteristics, i.e., calibration data. Sometimes (probably rare in LDR applications), the calibration data may be automatically and regularly acquired by self-test features associated with individual sensors. Other times, the calibration may involve steps to be performed by the operator. Calibration processing is covered in more detail later.

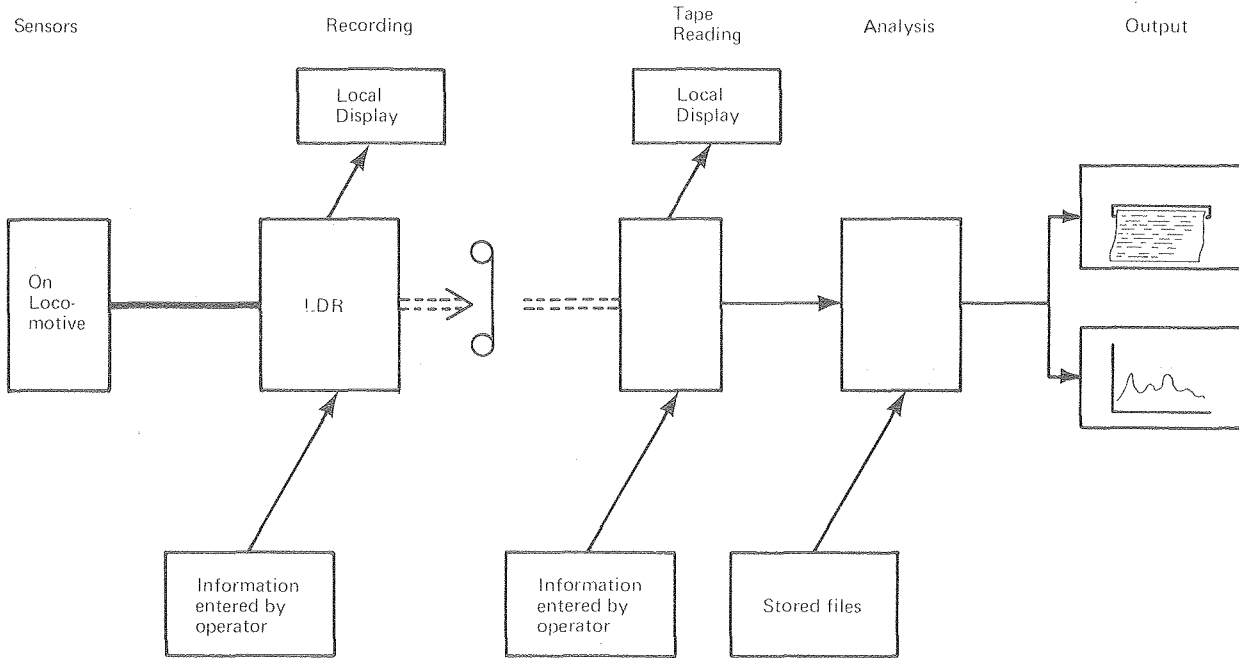

XBL 789-2229

Figure 27. Information Flow and Processing Functions of the LDAP.

- b. A second source of information is that generated by the operator(s) of the equipment. The term "operator" includes anyone who interacts with the LDAP system at some point in the total process. As mentioned above, the operator(s) may be involved in calibration processes by setting-up and recording standard conditions for some variable to be measured, and initiating the recording of the measurement.

The operator may also be involved with entering "fiducial" information into the system, i.e., information describing significant measurement conditions that is not recorded automatically. This could include a record of the types of sensors connected to LDAP, or of external conditions (e.g., weather, consist, date, etc.). The operator may also issue commands to the LDR. These could include instructions on sampling rates for various sensors, for example.

During the run, the operator may himself generate and record measurement data to supplement that from the sensors. Such data may include "significant events" such as passing mileposts or readings from gauges, etc.

After a run, additional operator interaction may be required to read the magnetic tapes generated by the LDR into the analysis system, and to cause the analysis system to perform the proper processing.

In order for the information and/or commands entered by the operator to be properly interpreted by the analysis computer, protocols by which the operator enters information must be designed.

- c. A third source of information is indicated in Table 6 by the term "Stored Files." This refers to bulk files of information too large to be handled in the same way as the recorded data, and which are therefore stored in a place and manner that make them accessible to the analysis computer.

One of the key members of this category is the set of computer programs used for the analysis and processing of LDR data. Depending on the particular computer installation, these would be stored on magnetic tape, disks, or other bulk-storage media. They would be called into the computer memory at the time the analysis job is to be run. These programs would have been prepared in advance using precise specifications of the nature and format of the input data, the analyses to be performed, and the nature and format of data to be output. Normally, a number of programs would be stored; the particular program to be executed would be commanded by an operator.

Another class of stored files includes ancillary data needed

during the processing. Examples are data describing characteristics of the rail system (e.g., track maps) or of the locomotive under test (e.g., locomotive specifications and characteristics). Typically, this information would be combined with the recorded data during the processing to obtain certain results. For example, milepost information from the recorded data might be used to determine the track grade by referring to the stored files.

After the processing of the recorded data from a particular run, stored files may also be used for archival storing of the results of that run. They may also be utilized in a "post-processing" mode for statistical purposes; the results of analyzing the present run may be merged with results from previous runs to generate a base of statistics or for averaging results.

Table 6. DATA/INFORMATION SOURCES

<u>Source</u>	<u>Information</u>
a. Sensors & Transducers	- Performance data
b. Operator	
On-vehicle	- Measurement conditions Recording instructions Significant events
On tape reader/processor	- Measuring conditions Processing instructions
c. Stored Files	- Track maps, locomotive characteristics Earlier files of results Processing program

6.4 RECORDING ALGORITHMS AND FORMATS

The subject of the algorithms or sequences used in acquiring and recording data has already been touched upon in a previous section. It is reintroduced here to emphasize the need for specifying data "formats", which are essential elements in the communication between functions of the system. Table 7 summarizes some recording algorithms that may be used in LDAP.

Table 7. SOME SAMPLING AND RECORDING ALGORITHMS (SEQUENCES)
THAT MAY BE EMPLOYED IN THE LDAP SYSTEM.

<u>Algorithms</u>	<u>Parameters That Must Be Specified</u>
Continuous sampling of selected measurand (e.g., speed, draw bar force)	Sampling rate for each measurand
Burst sampling (motor overloads)	Sampling rate(s) Trigger conditions Signal thresholds Computer thresholds Pre-trigger histories
Significant event recording (bells, mileposts)	Trigger conditions
Recorded one per run	Calibration data Fiducial information

The usefulness of any recorded number depends on knowing its origin -- i.e., where it came from, when it was recorded and what it represents. When a recorded tape is read into the processing end of the system, many thousands of numbers are transferred. In order to know the origin and significance of each and every number, some method of identification must have been predetermined. The identification is accomplished via the "format" used in transmitting and/or recording data. In the LDAP system, both fixed and variable formats will be used.

In a fixed format the identification of a word is fixed by its location within a group (e.g., tape record). For example, each time the group (record) having fixed format is encountered, the origin of each word in the group is known by its position within the group. In addition, the time at which a word was recorded can be deduced from the characteristics of the format.

In a variable format, each datum is accompanied by an identifier. The identifier may carry information such as the time of origin and the sensor or location from which it is originated.

Generally, fixed formats are preferred, where data is recorded at regular intervals, and hence the amount of recording medium that will be needed to record the data can be arranged in advance. When data is "sparse," i.e., is recorded at random or infrequent intervals, space in the recording media can usually be conserved by use of a variable format.

As shown in Table 7, various parameters will be sampled and recorded using various recording algorithms (sequences). The sequence used is a function largely of the time dependence of the sampling. Parameters recorded with a constant sampling rate will probably be recorded with a fixed format; those sampled at a non-constant rate (the last three categories in Table 7) will more likely fit better into a variable format.

The main point in this section is not to catalog these items specifically, but rather to point out some of the situations that must be considered in recording and analyzing the data. Again, the analysis program cannot use a datum unless it knows the significance of that datum.

6.5 ANALYSIS FUNCTIONS AND COMPUTER PROGRAMS

The analysis function consists of processing the raw numerical (or alphanumeric) data recorded by the LDR into a useful form. The definition of what is useful, and therefore what analysis is required, will vary from one experiment to another.

One objective of LDAP is to eliminate the need for human processing of the large amount of data acquired by the LDR. It is therefore anticipated that all analysis will be done by computers and hence, computer programs must be prepared.

The specification of a program requires knowledge of the raw information that is available from the tape, the type of processed information to be derived from the raw information, and the way in which the processed information is to be presented.

A program is usually designed to be executed in several segments, which are sometimes further subdivided. Some typical segments and sub-segments are listed in Table 8 and discussed below.

Table 8. TYPES OF PROCESSING TO BE PERFORMED BY COMPUTER PROGRAM

- * Tape reading and data formatting
- * Calibration
- * Reproduction of data strings
- * Data reduction
 - * Summation (total fuel used)
Numerical output
 - * Correlations (fuel economy at given speeds)
Histograms
 - * Analyses of particular events (motor overloads)
 - * Snapshots (energy balance)
 - * Listing of significant events
- * Generation of statistical files
- * Predetermined/Interactive

- a. Tape reading and formatting. The digital information on the magnetic tape will typically be in a form that cannot be used directly by the programs in the processing computer. For example, the typical word size used by LDR will probably not be the same as the word size of the computer; additionally, to conserve tape, LDR may use different word sizes for different variables. The computer processing will typically be done in several steps: it is convenient for illustrative purposes to consider the information on the tape to be a string of bits. In the tape reading and formatting process, groups of bits must be separated into words that are compatible with programs written in higher level languages, such as FORTRAN.

Typically, this formatting cannot be done using ASCII-standard FORTRAN. Many computer systems, however, have FORTRAN-callable functions or subprograms that can do the formatting. In the absence of these, an assembly language routine may be necessary. In general, the formatting routines will need to be special to the particular computer type or installation.

The end result of the tape reading and formatting is to have each individual datum in a form accessible to a processing program written in a higher-level language.

- b. Calibration. Calibration refers to the process of converting numbers recorded from sensors or transducers into engineering units. This requires having some auxiliary information on the characteristics of the transducers, i.e., calibration constants. As discussed earlier, calibration constants can be supplied to the processing program in various ways; for example, by calibration activities performed on the locomotive, or by information supplied to, or embedded in, the processing program.

A typical calibration algorithm is:

$$E = A + B \times L,$$

where

L = the raw measurement datum recorded by LDAP;

E = the value of the measured parameter, in engineering units;

A,B = calibration constants.

This algorithm is appropriate where linear conversions are valid. More complex algorithms, such as:

$$E = A + B \times L + C \times L^2 + D \times L^3 \dots$$

may be necessary for non-linear corrections. Where the conver-

sion cannot easily be specified in closed form, it may be necessary to store an array of conversion constants in a reference table.

- c. Analysis programs. These programs perform mathematical or logical manipulations on the data and produce the information that is of interest. Part of this procedure may be thought of as "data reduction," since it will typically take large numbers of individual measurements and reduce them to a smaller set of numbers that each carry more significant information.

It is expected that analysis programs will be written in a "higher-level" language such as FORTRAN or BASIC. Such programs have the advantage of being easier to write and understand than programs written in assembly languages. They are also "transportable" in that a majority of computer systems can utilize them directly without translation.

It is also expected that a number of such transportable programs will eventually be written to cope with the various types of analysis to be done. Part of the ongoing work in this project will be to determine the number and capabilities of these programs. As an illustration of this point, Table 7 lists some of the types of analysis that may be performed on LDR data. Not all of these will be required in any given problem.

- 1) Reproduction of Data Strings. This refers to the reproduction of a history of one or more individual variables. An example is the plotting, on a strip-chart, of the speed of the locomotive as a function of time. The processing is minimal. The program would typically provide for the choice of a variable to be plotted and the scale to which it is plotted.
- 2) Data Reduction. This refers to producing an output set of data that is less populous than the input set -- this is sometimes referred to as "number-crunching".

A good example to illustrate the use of data reduction is the problem of total amount of fuel used in a specified period. LDR would record the instantaneous fuel flow rate at periodic sampling times. The processing program would determine the total fuel used by integration, i.e., summing all the fuel flow rate numbers and multiplying by the sampling interval. The result, in this example, would be a single number obtained by reducing a large set of numbers. The program would, within reasonable limits, allow for the choice of variable to be summed, and the interval over which the summation takes place.

A subset of this procedure would be correlation, in which

the functional relationships between variables is explored. These procedures often lead to output in the form of histograms or tables. An example is the calculation of a set of numbers that describe fuel economy at various speeds. Since the speed of the train varies during a run, the program must sort the calculated results according to the instantaneous recorded speed.

Results of a set of calculations such as this are meaningful only if other conditions that could affect the result are constant -- if, for example, the above calculations were made on flat track. When other variables, such as grade, are important, the calculated results may need to be sorted according to combinations of variables.

The preparation of programs must be based on a priori decisions to select the variables that will be analyzed for functional dependence on other selected variables, and also regarding the resolution (size of bins) used in the sorting process.

As shown in Table 7, there are a number of other types of analyses that can be classified as data reduction. The same comments regarding a priori decisions on the programs to be analyzed are applicable.

- 3) Statistical Manipulations. It is expected that, in many cases, the results of a single run will be insufficient to draw meaningful conclusions. Typically, this may be so because measurements cannot be made to sufficient accuracy or because of the possible influence of unmeasured or uncontrolled variables.

For this reason it may be necessary to develop and store files of information that may be used to provide an expanded data base over the data available from a single run. This permits the accumulation of results from a number of runs, and allows the generation of output data based on this accumulation. Essentially all computer systems that could be used for this purpose will have the facility to store and retrieve such files, either on disc or magnetic tape storage. In this case, since the files are written and retrieved by the high-level language program, formatting of the files for reading and writing is handled automatically by the computer system. Problems may arise, however, if these files are transported from one system to another.

6.6 PREDETERMINED/INTERACTIVE PROGRAMMING

The preceding sections contained remarks about the need

to decide in advance what the analysis programs are to do. It should be pointed out, however, that provision can be made for certain decisions to be made at the time the program is run. In other words, the operator can be given the power to interact, to some degree, with the program. The most practical level, for our purposes, is probably to develop a rudimentary "very high-level" language. Such a language would be used to control the execution of the high-level (FORTRAN) language programs by specifying the names of variables, time intervals, resolutions, etc., used in the calculations.

7. REFERENCES

1. E.G. Schwarm. Engineering Cost Data Analysis for Railroad Electrification, report prepared for Transportation Systems Center, U.S. Dept. of Transportation, under Contract DOT-TSC-1156, October 16, 1976.
2. E.M. Harris, and C.E. Crede. Shock and Vibration Handbook (McGraw-Hill Book Co., New York, 1961), pp. 45-28 through 45-31.
3. R.L. Baxter and D.L. Bernard. Vibration Tolerances for Industry, ASME paper 67-PEM-14 (1967).
4. C.E. Crede. Vibration and Shock Isolation (John Wiley and Sons, Inc., New York, 1951), pp. 229-302.
5. Impact as Related to Freight Car and Lading Damage, ASME paper 59-A-249 (1959).
6. S. Rubin. Vibration Isolation on Nonrigid Supporting Structures, SAE Transactions, Vol. 6B (1960).
7. R.M. Phelan. Dynamics of Machinery (McGraw-Hill Book Co., New York, 1967), p. 214.
8. S. Rubin. Design of Vibration Isolation Systems, Society of Automotive Engineers (Pergamon Press, Ltd., Oxford, England, 1962).
9. E.M. Harris and C.E. Crede. Shock and Vibration Handbook (McGraw-Hill Book Co., New York, 1961), pp. 8-48 through 8-49.
10. D.S. Steinber. "Taking the Shake out of Circuit Boards," Machine Design, September 22, 1977, pp. 96-99.
11. "Industrial Load Cells," Product Engineer, March 1949, p. 11.
12. J. Vrabel, E. Sussman, and D. Ofsevit. Development of a System to Display and Record Slack Actions in Freight Trains, Report FRA/ORD-77-53, U.S. Dept. of Transportation, T.S.C., August 1977.
13. R. Anderson and P. Cramer. Train-to-Train Rear End Impact Tests, Vol. I -- Pre-Impact Determination of Vehicle Properties, Report FRA/ORD-73-303, I, U.S. Dept. of Transportation, T.S.C., March 1977.
14. J. Grey. "Transient Response of the Turbine Flowmeter," Jet Propulsion, Feb. 1958, p. 98.
15. J.N. Cetinich. Fuel Efficiency Improvement in Rail Freight Transportation, Report FRA-OR and D-76-136, U.S. Dept. of Transportation, December 1975.

16. B. Robertson and G. Baumgarten. "Evaluation of Automotive Fuel Flow Meters," National Bureau of Standards Technical Note 943, June 1977, pp. 42-45.

APPENDIX A

LOCOMOTIVE DATA ACQUISITION PACKAGE (LDAP) FUNCTIONAL SPECIFICATION

INTRODUCTION

This specification outlines the functional characteristics of a Locomotive Data Acquisition Package to be used for the recording and subsequent analysis of locomotive operating parameters.

The LDAP is divided into three sections. The first section, which will be carried on-board a locomotive, shall contain the recording mechanism, the signal conditioning and processing hardware, sensors, the enclosure and additional apparatus necessary to ensure that the system operates in accordance with this specification. The first section will hereafter be referred to as the "Locomotive Data Recorder (LDR)." The second section, which will be used in an office environment, shall contain the magnetic tape playback unit, a data modem, a computer terminal, plus equipment necessary to read a previously recorded digital magnetic tape and transmit the information to an off-site digital computer. This second section will also contain a means of accessing the off-site digital computer used for data analysis. This second section is referred to as the LDAP Playback unit. The third section shall contain the software necessary to reconstruct and manipulate the data as required to perform a selected measurement task. The software will be used initially on the LBL-CDC-7600 computer, but will be written so as to facilitate its use on other suitable computers.

LOCOMOTIVE DATA RECORDER (LDR)

1. GENERAL ENVIRONMENT SPECIFICATIONS

TEMPERATURE: -40°F to +140°F

HUMIDITY: 0% to 95% @ 100°F

VIBRATION: 1.5 G at 2-30 Hz sine wave, any direction per MIL-STD-810C (curve W).
4.2 G at 30-500 Hz sine wave, any direction.

SHOCK: 10 G half sine wave for 30 msec., any direction per MIL-STD-810C.

MAXIMUM WEIGHT: 100 lbs exclusive of sensors and sensor hardness.

MAXIMUM VOLUME: 3 1/2' x 2' x 1'

CONTAMINATION: Dirty, gritty, dusty, heavy industrial environment.

VANDALISM: Tamper-proof enclosures are required.

ELECTRICAL NOISE ON INPUT PORTS: All signal lines will be shielded and filtered to withstand ± 200 V overvoltage. Special protection and isolation will be provided for connections to high voltage circuits.

POWER SUPPLY: 68 V dc ± 8 V, ungrounded; occasional 20,000-V spikes of 1 msec period, sourced from a 2- Ω source. A ripple voltage of 4 V ac, 50-400 Hz is assumed.

CURRENT DRAWN FROM POWER SUPPLY: 6 A maximum

EMI: Will exceed MIL-STD-461A for susceptibility (conducted and radiated).

2. FUNCTIONAL CHARACTERISTICS

RECORDING MEDIUM: 3M DC-300A 4-track digital data cartridge; 300 ft of 1/4" tape.

DATA CAPACITY: 34,000,000 bits; 2,000,000 8-bit data records.

MAXIMUM SAMPLE RATE: 2,000 samples per second

ANALOG CHANNELS: 32 differential analog input ports, 14 of which are dedicated to the basic sixteen parameter set (CMRR greater than 60 db).

DIGITAL CHANNELS: 16 differential digital input ports, 2 of which are dedicated to the basic parameter set.

ISOLATION BETWEEN CHANNELS: Greater than 70 dB

RECORDING FORMAT: ANSI/ECMA specified phase encoded (BiPhase Level) at 1,600 BPI.

DATA FORMAT: Data will be recorded in blocks, each block containing calibration, header, and ID information. Each block will contain approximately 1,000 data samples.

SAMPLING SEQUENCE: Sample rates and channels to be recorded will be selectable (programmable) by the user. Channels will be selectable in any sequence.

CALIBRATION: Calibration signals will automatically be injected as part of the recording process. These signals will be injected at a point that corresponds to the analog input to the LDR.

SELF-TEST: Self-test features will be provided.

TIMING MARKERS: Unique timing markers corresponding to the data and time of day will be provided and recorded with all-event data, and with each block of time-sampled data.

POST TRIGGERING: The capability to record up to 1,000 data samples that occurred prior to a specific event will be provided. That is, it will be possible to record the history of a parameter over a time interval from 1000 samples before an event trigger until a specified time thereafter.

KEYBOARD/UMBILICAL: A keyboard will be provided. Use of the keyboard will allow sample rates to be changed, channels to be assigned to sensors, and transducer values monitored. It will also provide for the input of event or mile-post information. Provisions will be made for either a separate, smaller keyboard on an umbilical, or the full keyboard on an umbilical for event and status type input/output.

3. MEASURANDS

The following parameters shall be recorded and transducers and cabling be provided where necessary.

<u>Measurand</u>	
Speed	Sampled
Independent Brake Pressure	Sampled
Trainline Brake Pressure	Sampled
Buff/Draft Forces	Sampled
Traction Alternator Voltage	Sampled
Traction Alternator Current	Sampled
Dynamic Brake Current	Sampled when used
Grade	Sampled
Throttle Setting	Event when changed
Reverser Setting	Event when changed
Slip-Spin	Event
Fuel Flow In	Sampled

Fuel Flow Out	Sampled
Air Temperature	Sampled
Turbo Charger Pressure	Sampled
Engine Temperature	Sampled

The following parameters will be derived from the original 16 listed above:

- Distance traveled
- Total work done
- Time in Notch
- Time in Motion

Sampled means the measurand will be sampled and recorded at a rate that may be adjusted between 1 sample/hr to 100 samples/sec, within the limitation of 2,000 total samples/sec for all parameters.

Event means the time history of selected parameters can be recorded for a pre-determined time before and after a trigger based on some pre-selected conditions of the measurand.

Event when sampled means the time history consists of one sample of the indicated measurand.

PLAYBACK UNIT

The LDAP playback unit will include a playback tape recorder, a commercial computer data terminal and a data modem. It will provide for the transmission of previously recorded locomotive data and operator commands to an off-site digital computer and for the reception and display of information from that computer.

ANALYSIS SOFTWARE

Software routines to execute a pre-selected measurement task will be written and fully documented. These will be initially used on the LBL CDC-7600 computer complex. They will be written in a way to facilitate their use at other suitable computers and to facilitate the expansion of application to other tasks.

- FORTRAN ACCESSIBLE ARRAYS: Software will be provided (in the form of subroutines callable from FORTRAN) that will program a selected off-site computer to accept the stream of data samples from the Playback Unit. These subroutines will structure and format the data samples into fixed arrays accessible by a high level computer language, such as FORTRAN.
- CALIBRATION CHECKS: The capability to verify LDR calibration will be provided where applicable to the pre-selected task; the following types of software routines will be provided.
- SUMMATIONS: The capability to perform numerical summations will be provided. For example, total fuel used from point to point, time in notch, etc.
- CORRELATIONS: The capability to correlate two parameters and to generate histograms will be provided. For example, fuel economy as a function of speed, speed as a function of time, etc.
- COMPUTATIONS: The capability to perform arithmetic computations will be provided.
- SNAPSHOT VIEWS: The capability to examine all of a selected group of parameters at a particular location, or at a particular time, will be provided.
- EVENTS: The capability to search for and list significant events will be provided. For example, time of occurrence of all brake pipe reductions greater than 20 psi, or of slip/spin activity, etc.

STATISTICAL FILES:

The capability to merge LDAP data with existing data files of a fixed format will be provided. For example, track map information, or previously analyzed LDAP data. The software will be designed so as to be compatible and usable with statistical analysis routines.

This report was done with support from the Department of Energy. Any conclusions or opinions expressed in this report represent solely those of the author(s) and not necessarily those of The Regents of the University of California, the Lawrence Berkeley Laboratory or the Department of Energy.

TECHNICAL INFORMATION DIVISION
LAWRENCE BERKELEY LABORATORY
UNIVERSITY OF CALIFORNIA
BERKELEY, CALIFORNIA 94720