

Lawrence Berkeley National Laboratory

Recent Work

Title

HYPERFINE STRUCTURE AND NUCLEAR MOMENTS OF 17-HR BROMINE -76

Permalink

<https://escholarship.org/uc/item/9gc2j1kh>

Authors

Lipworth, Edgar
Green, Thomas M.
Garvin, Hugh L.
et al.

Publication Date

1959-12-17

UNIVERSITY OF
CALIFORNIA

Ernest O. Lawrence

*Radiation
Laboratory*

TWO-WEEK LOAN COPY

*This is a Library Circulating Copy
which may be borrowed for two weeks.
For a personal retention copy, call
Tech. Info. Division, Ext. 5545*

BERKELEY, CALIFORNIA

DISCLAIMER

This document was prepared as an account of work sponsored by the United States Government. While this document is believed to contain correct information, neither the United States Government nor any agency thereof, nor the Regents of the University of California, nor any of their employees, makes any warranty, express or implied, or assumes any legal responsibility for the accuracy, completeness, or usefulness of any information, apparatus, product, or process disclosed, or represents that its use would not infringe privately owned rights. Reference herein to any specific commercial product, process, or service by its trade name, trademark, manufacturer, or otherwise, does not necessarily constitute or imply its endorsement, recommendation, or favoring by the United States Government or any agency thereof, or the Regents of the University of California. The views and opinions of authors expressed herein do not necessarily state or reflect those of the United States Government or any agency thereof or the Regents of the University of California.

UNIVERSITY OF CALIFORNIA

Lawrence Radiation Laboratory
Berkeley, California

Contract No. W-7405-eng-48

THE HYPERFINE STRUCTURE AND NUCLEAR MOMENTS
OF 17-HR BROMINE-76

Edgar Lipworth, Thomas M. Green,
Hugh L. Garvin, and William A. Nierenberg

December 17, 1959

THE HYPERFINE STRUCTURE AND NUCLEAR MOMENTS
OF 17-HR BROMINE-76

Edgar Lipworth, Thomas M. Green,
Hugh L. Garvin, and William A. Nierenberg

Lawrence Radiation Laboratory
University of California
Berkeley, California

December 17, 1959

ABSTRACT

The nuclear spin, the nuclear magnetic-dipole interaction constant \underline{a} , and the nuclear electric-quadrupole interaction constant \underline{b} , have been determined for 17-hr bromine-76 by an atomic-beam experiment. The results are:

$$I = 1$$

$$|\underline{a}| = 345.422 \pm 0.014 \text{ Mc/sec}$$

$$|\underline{b}| = 314.329 \pm 0.022 \text{ Mc/sec}$$

$$\underline{b}/\underline{a} = .9100 \pm 0.0001$$

The nuclear magnetic-dipole and electric-quadrupole moments are calculated to be, respectively,

$$\mu = \pm 0.5479 \pm 0.0001 \text{ nuclear magnetic}$$

and

$$Q = \mp 0.27 \pm 0.01 \text{ barns.}$$

The sign of μ , though not determined, is probably negative.

The hyperfine structure separations are

$$\Delta\nu (5/2, 3/2) = 1256.47 \pm 0.05 \text{ Mc/sec}$$

and

$$\Delta\nu (1/2, 3/2) = 189.11 \pm 0.05 \text{ Mc/sec.}$$

The hyperfine structure is of particular interest because the $F=1/2$ and $3/2$ levels are inverted and not in normal order. This inversion is the first case of its kind established in an atomic-beam experiment.

THE HYPERFINE STRUCTURE AND NUCLEAR MOMENTS
OF 17-HR BROMINE-76*

Edgar Lipworth, Thomas M. Green,
Hugh L. Garvin, and William A. Nierenberg†

Lawrence Radiation Laboratory
University of California
Berkeley, California

December 17, 1959

INTRODUCTION

The nuclear spin and hyperfine energy-level separations in 17-hr Br^{76} have been measured by the atomic-beam method. From these measurements the nuclear magnetic-dipole and electric-quadrupole moments of Br^{76} have been calculated. The results are of interest for two reasons: (a) The ratio b/a of the electric-quadrupole and magnetic-dipole interaction constants is of such a magnitude and sign as to produce an inversion of two hyperfine levels. This inversion, which permits observation of an additional transition not normally visible in an atomic-beam flop-in experiment, is the first of its type explicitly recognized.¹ (b) The nucleus of Br^{76} contains the same number of neutrons as Se^{75} , which is known to possess an anomalously large nuclear electric-quadrupole moment. The measurement of similar large quadrupole moments in this region of the periodic table might perhaps confirm the existence here of collective effects of nuclear motion.

*This work was done under the auspices of the U. S. Atomic Energy Commission.

†At present in the Miller Institute for Basic Research in Science, University of California, Berkeley, California.

THEORY

The nuclear spin of Br⁷⁶ is one.² There is, therefore, no interaction between the nucleus and the field generated by the surrounding electrons of order greater than the electric-quadrupole interaction. The complete Hamiltonian of the interaction (neglecting only small perturbations from other configurations) can therefore be written as

$$\mathcal{H} = \underline{a} \vec{I} \cdot \vec{J} + \underline{b} Q_{op}. \quad (1)$$

Here \underline{a} and \underline{b} are the nuclear magnetic-dipole and electric-quadrupole interaction constants, I is the nuclear spin, J is the electronic angular momentum, and Q_{op} is given by

$$Q_{op} = \frac{3(\vec{I} \cdot \vec{J})^2 + 3/2(\vec{I} \cdot \vec{J}) - I(I+1)J(J+1)}{2I(2I-1)J(2J-1)}. \quad (2)$$

In the absence of an applied magnetic field, $\vec{F} = \vec{I} + \vec{J}$ is a constant of the motion where $|\vec{F}| = \sqrt{F(F+1)} \hbar$. The quantum numbers F , and M_F , the projection of \vec{F} in units of \hbar along an axis of quantization, are constants of the motion, and in a representation in which $(\vec{F})^2$ and M_F are taken diagonal, $(\vec{I} \cdot \vec{J})$ and Q_{op} are diagonal matrices. In this representation, the solution of Eq. (1) can be written

$$(W/\underline{a})_F = C_1(F) + C_2(F) (\underline{b}/\underline{a}), \quad (3)$$

where $C_1(F)$ and $C_2(F)$ are constants depending only upon F for a given I and J . The energy (in units of \underline{a}) of a given hyperfine level characterized by total-angular-momentum quantum number F is $(W/\underline{a})_F$. It is clear from the form of Eq. (3) that a plot of $(W/\underline{a})_F$ versus $\underline{b}/\underline{a}$ will be a straight line which will

in general have a different slope for each value of F . A plot of $(W/\underline{a})_F$ is shown in Fig. 1 for values of I and J appropriate to Br^{76} (i. e. 1 and $3/2$, respectively). For vanishing quadrupole moment, we have $b = 0$, and the hyperfine levels are in normal order and the separation between F levels satisfies the well-known Landé interval rule. If $\underline{b}/\underline{a}$ is less than -2 or greater than $2/3$, the levels are no longer in normal order and an inversion will be said to exist. It is necessary for present purposes to investigate the consequences of $\underline{b}/\underline{a}$ lying between $2/3$ and 4 . First we remark that if the hyperfine levels are in normal order there are only two transitions observable in an atomic-beams flop-in experiment on an isotope with $I = 1$ and $J = 3/2$. These transitions are labeled α and β in Fig. 2a. If, however, the $F = 1/2$ and $F = 3/2$ levels are inverted, the level diagram must be drawn as in Fig. 2b, and it will be seen that an additional transition labeled (γ), is now observable. This is the case for $2/3 < \underline{b}/\underline{a} < 4$.

At low values of the applied magnetic field (i. e. in the linear Zeeman region) the frequency of any of the above three transitions is given by the expression $\nu = g_F (\mu_0 H)/h$, where H is the magnetic field, μ_0 is the Bohr magneton, h is Planck's constant, and g_F is defined by

$$g_F \approx g_J \left\{ \frac{F(F+1) + J(J+1) - I(I+1)}{2F(F+1)} \right\}. \quad (4)$$

In this expression for g_F , a small term in g_I , the nuclear g factor, has been neglected. The electronic g factor is g_J .

In order to determine the nuclear spin of an isotope, resonances are sought at two or three known magnetic fields in the linear Zeeman region. The resonance frequency and its slope against the magnetic field uniquely determine both F and I except for $I = 0$. In practice, one observes as many

flop-in resonances as are permitted by the level ordering and angular-momentum values of the system.⁴

As the magnetic field is increased to a point where the interaction of the electronic magnetic moment with the field is no longer negligible compared with the interaction between the nuclear and electronic magnetic moments (i. e. $g_J \mu_0 \vec{J} \cdot \vec{H} \sim \underline{a} \vec{I} \cdot \vec{J}$), the transition frequency ν does not remain a linear function of H and must be calculated by solving the complete Hamiltonian of the system with the field applied. This Hamiltonian is

$$\mathcal{H} = \underline{a} \vec{I} \cdot \vec{J} + b Q_{op} - g_J \mu_0 \vec{J} \cdot \vec{H} - g_I \mu_0 \vec{I} \cdot \vec{H}. \quad (5)$$

An I. B. M. 650 computer has been programmed to solve this Hamiltonian. Two programs have been developed, one which calculates the energy levels as a function of H for given values of \underline{a} and \underline{b} , the other which calculates the best values of \underline{a} and \underline{b} from the experimental resonance data. The second program calculates the best values of \underline{a} and \underline{b} for both signs of the nuclear moment and tests the goodness of fit by the χ^2 test of significance. These programs and the way they are used for the determination of hyperfine interaction constants have been described in detail elsewhere.⁵ In the present case, both α and β resonances were observed at increasing values of magnetic field under the assumption of normal ordering of the F levels. It soon became apparent that a consistent fit to the data could not be obtained under the assumption of normal ordering, and a level inversion was suspected. It will be noted from Fig. 2b that the M_F values that go with the levels of the β transition are different depending on whether or not there is an inversion. Since these M_F values are part of the input data to the programs, the results were processed by using the M_F values appropriate to the inversion of Fig. 2b,

and a consistent fit to the data was obtained. In addition, the field dependence of the resonances was checked by perturbation-theory calculations. The predicted third resonance (γ) was subsequently observed.

EXPERIMENTAL

Bromine-76 is produced from arsenic by the reaction $As^{75}(\alpha, 3n)Br^{76}$. As there is only one stable isotope of arsenic, little undesired activity is produced. The 77-hr Br^{77} produced by the $(\alpha, 2n)$ reaction has been observed but has in no way interfered with the measurements on Br^{76} . The α -particle beam of the Berkeley 60-in. cyclotron is used at full energy at a current of about 20 microamperes, and approximately 70 microampere-hours of irradiation yields sufficient activity for several hours of operation. The target is prepared by placing about 2 grams of arsenic powder in a depression stamped in a 0.010-in. aluminum plate; two 0.001-in. aluminum foils are placed over the powder, and the whole assembly is clamped in an aluminum target block. During irradiation the plate containing the powder is water-cooled, while the front foil is exposed to a helium atmosphere both for cooling and to prevent possible leakage of material into the cyclotron vacuum chamber.

The bromine is separated chemically from the arsenic by means of the apparatus shown in Fig. 3. Dry helium is passed continuously from left to right and the oven vial cooled with liquid nitrogen. The arsenic and the requisite amount of carrier bromine (in the form of KBr powder) is placed in the reaction vessel, and concentrated sulfuric acid and hydrogen peroxide are added. The bromine passes over the P_2O_5 drying agent and condenses in the oven vial. The vial is allowed to stand open for a few

minutes in ice water to allow condensed reaction products other than bromine to escape and is then cooled in liquid nitrogen again and transferred to the atomic-beam apparatus. The bromine is allowed to effuse at room temperature through a leak of the type described by Gordon⁶ into the discharge tube shown in Fig. 4. This discharge tube is similar to one described previously but in the present design the tube is more easily replaced.⁽⁷⁾ Electrical contact is made by nickel spring leads which contact nickel foils wrapped and spot welded around the tube. The quartz tube under the foils is painted with Aquadag to increase capacitative coupling to the discharge.

The beam is collected on buttons coated with evaporated silver and detected by counting the decay β -particles from Br^{76} in small-volume continuous-flow methane beta counters. Observations were made by using a full-beam counting rate of about 75 counts per minute per minute of exposure; resonance buttons were usually exposed for 5 min. The liquid bromine consumption was approximately 0.3 cc/hr when a leak with an "apparent diameter"⁽⁶⁾ of 2.3 microns was used.

The atomic-beam machine used in this experiment has been described elsewhere.⁷ The homogeneous transition field (C field) is calibrated with an alkali reference beam and a surface-ionization detector. Cesium and potassium beams were used interchangeably for this purpose. At low magnetic fields, the potassium resonance half width at optimum rf power was about 100 kc.

RESULTS

Initial exposures made at low magnetic field established the nuclear spin to be one. High-counting buttons were obtained at frequencies corresponding to the (α) and (β) transitions, and two resonances were observed in detail at a field of 2.86 gauss (1 Mc/sec Cs). Decay plots of both full-beam and resonance buttons showed negligible contamination by other activities, and the observed half life of Br⁷⁶ agreed within statistics with previously published values (17.2 hrs⁸ and 17.5 hrs)⁹.

Subsequently, the α and β transitions were observed at several values of magnetic field ranging as high as 265.7 gauss for the α resonance and 27.6 gauss for the β resonance. Representative α and β resonances are shown in Figs. 5 and 6 observed at 111.0 and 17.1 gauss, respectively.

When a level inversion was suspected, a search was made for the flop-in transition in the $F = 1/2$ state, designated as gamma. Gamma transitions were observed at 1.4, 6.9, 13.4, and 28.4 gauss, exhibiting in each case a broad line as expected from the very high g_F value of 2.22. A representative gamma resonance observed at 6.9 gauss is shown in Fig. 7. The least-squares¹ I. B. M. routine resulted in a consistent fit to the data with a b/a value of 0.9. By the use of frequency predictions based on this value of b/a , observations of the β transition were carried up to 64.6 gauss. At this value the calculated uncertainties in the hyperfine splittings, $\Delta\nu$, were small enough so that a low-field search for the direct ($\Delta F = \pm 1$) transitions could be made. This resulted in the observation of $\Delta\nu(1/2, 3/2)$ at 19.6 gauss and $\Delta\nu(5/2, 3/2)$ at 1.4 and 6.9 gauss.

Table I contains all resonance data that contribute to a knowledge of the interaction constants \underline{a} and \underline{b} together with the experimental uncertainties in the calibrating-beam and bromine-resonance frequencies. Also included in the last column of Table I is Δ , the difference between the observed resonance frequencies and those calculated using the best values of \underline{a} and \underline{b} . The uncertainties have been taken as $1/5$ and $1/3$ of the resonance half widths at half height for alkali and bromine resonances respectively. In Table II we have listed the I. B. M. outputs for g_I assumed positive and negative together with the values of χ^2 obtained in each case. The values of χ^2 indicate how closely the calculated \underline{a} and \underline{b} values fit the observed data while the relative magnitude of χ^2 for the different signs of g_I is expected to determine the actual sign of g_I .¹⁰ In the present case, because of an excessive apparatus line width no conclusion can be drawn as to the actual sign of g_I . We adopt as the final values of \underline{a} and \underline{b} the average of the results in Table II, with an assigned uncertainty equal to that computed for each. Thus we have

$$|\underline{a}| = 345.422 \pm .014 \text{ Mc,}$$

$$|\underline{b}| = 314.329 \pm .022 \text{ Mc,}$$

and $\underline{b}/\underline{a} = .9100 \pm 0004.$

TABLE I

Compilation of experimental resonance data observed in Br⁷⁶

Resonance type	Resonant frequency (Mc/sec)	Calibration frequency (Mc/sec)	Alkali	$\delta\nu^a$ (Mc/sec)	δf^a (Mc/sec)	Δ^b (Mc/sec)
β	16.95	4	Cs	0.02	0.106	-0.04
β	26.3	6	Cs	0.04	0.103	-0.1
α	64.25	20	Cs	0.04	0.083	-0.07
α	128.6	40	Cs	0.04	0.086	+0.08
α	325.7	100	Cs	0.02	0.113	+0.02
β	44.9	22	K	0.04	0.150	0.10
γ	41.6	10	K	0.03	0.150	0.05
γ	86.5	10	Cs	0.03	0.166	-0.14
γ	86.5	10	Cs	0.04	0.233	-0.14
β	78.6	16	Cs	0.04	0.466	-0.05
β	78.7	16	Cs	0.04	0.200	-0.15
β	118.8	23	Cs	0.05	0.166	-0.04
$\Delta\nu(1/2, 3/2)$	213.6	15	K	0.02	0.076	-0.002
$\Delta\nu(5/2, 3/2)$	1254.75	1	K	0.03	0.015	-0.03
$\Delta\nu(5/2, 3/2)$	1248.36	5	K	0.04	0.06	-0.06

^aHere $\delta\nu$ and δf are 1/5 and 1/3 of the resonance widths at half height for the calibrating beam and bromine resonances, respectively, and

^b Δ is the deviation in megacycles per second of the observed resonance frequency from that calculated using the best values of a and b.

TABLE II

Values of \underline{a} and \underline{b} computed by I. B. M. routine described in reference 5 and using the resonances of Table I as input data.

\underline{a} (Mc/sec)	\underline{b} (Mc/sec)	g_I^a	χ^2_b
345.423±.014	314.326±.022	+	2.7
345.421±.014	314.331±.022	-	2.8

^a The calculations have been made for g_I assumed positive and negative.

^b The difference between the two values of χ^2 listed is not sufficient to determine the sign of the nuclear moment.

Corrections due to the finite size of the nucleus and nuclear ~~and~~ magnetic-moment distribution are negligible for atoms of moderate Z in pure $^2P_{3/2}$ ground states and can be neglected. Corrections due to the mixing in of the $P_{1/2}$ state by the applied magnetic field are small and can be ignored.

The zero-field hyperfine structure can be obtained best by solving the Hamiltonian of Eq. (2) with $I = 1$ and $J = 3/2$. The result is

$$\Delta\nu(5/2, 3/2) = 2.5\underline{a} + 1.25\underline{b}$$

and

$$\Delta\nu(1/2, 3/2) = 1.5\underline{a} - 2.25\underline{b}. \quad (6)$$

Substituting in the experimentally determined values of \underline{a} and \underline{b} , we find

$$\Delta\nu(5/2, 3/2) = 1256.47 \pm .05 \text{ Mc}$$

and

$$\Delta\nu(1/2, 3/2) = 189.11 \pm .05 \text{ Mc}. \quad (7)$$

The complete hyperfine-structure diagram of Br^{76} is shown in Fig. 8.

NUCLEAR MOMENTS OF Br^{76}

A. Magnetic Moment

The valence-electron configuration for bromine is $4p^5$. For this case where one electron is missing from a closed shell, \underline{a} and \underline{b} are related to g_I , the nuclear g factor, and Q , the nuclear electric-quadrupole moment, by the expressions^{11, 12}

$$\underline{a} = \frac{\mu_0^2}{h} \cdot g_I \mathcal{F} \frac{2L(L+1)}{J(J+1)} \left\langle \frac{1}{r^3} \right\rangle \quad (8a)$$

and

$$\underline{b} = \frac{-e^2}{h} Q \mathcal{R} \frac{2L}{2L+3} \left\langle \frac{1}{r^3} \right\rangle \quad (8b)$$

For bromine the relativistic correction factors \mathcal{F} and \mathcal{R} are $\mathcal{F} = 1.0261$ and $\mathcal{R} = 1.0535$. The nuclear gyromagnetic ratio g_I is related to the magnetic moment μ by $g_I = \left(\frac{m}{M}\right)\left(\frac{\mu}{I}\right)$, where μ is expressed in nuclear magnetons, and m and M are the electron and proton mass, respectively. Other symbols have their usual meanings.

From Eq. (8a) and the definition of g_I we have

$$\frac{\underline{a}(\text{Br}^{76})}{\underline{a}(\text{Br}^S)} = \frac{\mu^{76}}{\mu^S} \cdot \frac{I^S}{I^{76}}, \quad (9)$$

where μ^S is the nuclear magnetic moment and I^S the nuclear spin of the stable bromine isotope Br^S . Using the results of King and Jaccarino¹⁴ for the \underline{a} values of Br^{79} and Br^{81} together with the nuclear moments of the same isotopes measured by Walchli¹⁵, we find

$$|\mu^{76}| = 0.5479 \pm 0.0001 \quad (\text{Br}^{79}) \quad (10)$$

and

$$|\mu^{76}| = 0.5479 \pm 0.00003 \quad (\text{Br}^{81}).$$

These values of the moment include the diamagnetic correction. The sign of the moment is not determined in this experiment, but because \underline{a} and \underline{b} both have the same sign, μ and Q must be opposite in sign.

B. Electric-Quadrupole Moment

From Eq. (8), we find

$$Q = 8/3 \frac{(\mu_0)}{e} \frac{m}{M} \frac{\mu}{I} \left(\frac{Z}{R} \right) \left(\frac{b}{a} \right). \quad (11)$$

Introducing the measured values of a for the stable isotopes Br^{79} and Br^{81} and the values of μ listed by Walchli¹⁵, we find in both cases

$$Q = 0.26 \text{ barns.}$$

In order to obtain the true nuclear quadrupole moment, Q_t , a correction factor, C , such that $Q_t = CQ$ is introduced. This factor, first calculated by Sternheimer, allows for the changed interaction of the valence electron with the inner core of electrons in the presence of the polarizing field due to the nuclear-quadrupole moment. This constant C has been calculated for bromine by Sternheimer but with the neglect of certain antishielding corrections.^{16, 17} The value of C is 1.040, but in view of the uncertainty in the exact value, we have chosen to assign an uncertainty to Q_t equal to the value of the correction itself. Thus we have

$$Q_t = 0.27 \pm 0.01 \text{ barns.}$$

The value of Q can be calculated by an alternative procedure which uses the fine-structure separation, δ , to obtain a value of $\left\langle \frac{1}{Y^3} \right\rangle$. Here δ is related to $\left\langle \frac{1}{Y^3} \right\rangle$ by the expression¹⁸

$$\delta = \frac{\mu_0^2}{hc} Z_i (2L+1) \int (Z_i) \left\langle \frac{1}{Y^3} \right\rangle, \quad (12)$$

where we have $\delta = 3685 \text{ cms}^{-1}$, Z_i is the effective value of the nuclear charge, and $\kappa(Z_i)$ is a relativistic correction factor tabulated by Kopfermann.¹³ Barnes and Smith have shown $Z_i = Z - n$ approximately, where n is the principle quantum number of the valence electron.¹⁹ For bromine, we have $n = 4$ and $Z_i = 31$. The value of Q_e obtained by using $\langle \frac{1}{Y^3} \rangle$ from Eq. (12) is 0.25 barns, and the corrected quadrupole moment Q_t is 0.26 barns. The uncertainty in the value of Q_t arises both from the uncertainty in Z_i and the uncertainty in the Sternheimer correction; Z_i is known to perhaps 5%. Thus we have finally $Q_t = 0.26 \pm 0.02$ barns.

The agreement between the two methods of calculation is satisfactory.

DISCUSSION

We shall first examine the results for Br^{76} from the point of view of the single-particle model of the nucleus.²⁰ The odd-even isotopes of bromine-- Br^{77} , Br^{79} , and Br^{81} --are all known to have spin $3/2$.²¹ We will assume that the proton contribution to the spin of Br^{76} is also $3/2$ and that it arises from the odd proton in the $p_{3/2}$ level. The expected contribution from the forty-first neutron is less obvious. It might lie in either of the two closely spaced levels $g_{9/2}$ or $p_{1/2}$, depending upon whether or not pairing takes place. If the odd neutron is supposed to enter the $g_{9/2}$ level, a spin of 1 cannot result, but if pairing is assumed to take place, the neutron configuration would be $(g_{9/2})_0^2 (p_{1/2})_{1/2}^{-1}$, and on the basis of Nordheim's strong rule a spin of 1 would be obtained. The spin of Se_{43}^{77} is known to be $1/2$, which lends support to the pairing hypothesis, though Ge_{41}^{73} exhibits a spin of $9/2$.

Aamodt and Fletcher have measured the spin of Se_{41}^{75} , an isotope with the same number of neutrons as Br^{76} , to be $5/2$.²² This rather surprising result has no very obvious explanation in terms of the single-particle shell model. In addition, the quadrupole moment is exceptionally large (1.1 barns). Aamodt and Fletcher suggest three possible configurations, all with a positive quadrupole moment, that would give rise to the observed spin. These are listed in Table III together with their magnetic moments calculated by using the free-neutron g value. As the nuclear moment of Se^{75} is not known, it is impossible to decide between the various possibilities. In column 3 of Table III we have listed the magnetic moments of Br^{76} calculated on the assumption that the neutron part of Br^{76} is similar to that of Se^{75} and that the proton part is similar to that of the stable bromine isotopes whose moments are known. The calculation has been made on the assumption that the neutron and proton parts couple together in (JJ) coupling, i. e. that the moment of Br^{76} is given by²³

$$\mu = 1/2 \left[(g_p + g_n)I + (g_p - g_n) \frac{J_p(J_p + 1) - J_n(J_n + 1)}{I + 1} \right], \quad (13)$$

where $(g_p, g_n$ and $J_p, J_n)$ are the neutron- and proton-part g values and angular momenta respectively and I is the nuclear spin. In the last line of Table III we have listed the moment of Br^{76} calculated in the same way using the neutron configuration $\left[(g_n/2)_0^2 p_{1/2} \right]$.

It is obvious that no very satisfactory agreement exists between the calculated and experimental values of the moment of Br^{76} , and it is unlikely therefore that the configurations suggested for Se^{75} have much validity. The configuration $\left[(g_n/2)_0^2 p_{1/2} \right]$ is rendered additionally unlikely by the fact that in this case μ and Q both have the same sign.

TABLE III

Calculated values of the magnetic moment of Br^{76} using the neutron configuration suggested by the sign of the quadrupole moment of Se^{75} . The last configuration is suggested by an application of Nordheim's rule, but is rendered unlikely by the relative signs of the magnetic and quadrupole moments. The calculations have been performed using the free-neutron g value and a value of g_p obtained from the known moments of Br^{79} and Br^{81} .

Neutron configuration	μSe^{75} (nm)	μBr^{76} (nm)	Q	$\mu(\text{Br}^{76})_{\text{exp}}$ (nm) abs. value
$[p_{1/2}(g_{9/2})^2]_{5/2}$	-0.21	-1.2	>0	0.55
$[(g_{9/2})^3]_{5/2}$	-1.1	-1.8	>0	
$[(f_{5/2})^5]_{5/2}$	-1.4	-2.0	>0	
$[(g_{9/2})^2 p_{1/2}]_{1/2}$	-	1.13	>0	

In the nuclear ground state, the quadrupole moment Q is related to the intrinsic quadrupole moment Q_0 by the expression²⁴

$$Q = \frac{I(2I-1)}{(I+1)(2I+3)} Q_0, \quad (14)$$

and we find

$$Q_0 (\text{Br}^{76}) = 2.7 \text{ barns.}$$

This large value of Q_0 suggests strongly the possibility of a collective deformation of the nuclear core, and it is of interest to investigate if the Nilsson model is capable of giving a satisfactory explanation of the observed spin and moments.²⁴ Nilsson has calculated the energies of bound states of individual nucleons in the field of a deformed core and has expressed the results in terms of a deformation parameter, δ . This parameter δ is related to Q_0 by the expression.

$$Q_0 = 0.8 Z (1.2 \times 10^{-13} A^{1/3})^2 \delta (1 + 2/3\delta). \quad (15)$$

For Br^{76} we find $\delta = 0.31$. The nuclear energy levels are shown plotted against the deformation parameter δ in Fig. 5 of Nilsson.²⁴ At a δ value of 0.31 there is crowding of the available neutron and proton levels, and it is not possible to state unequivocally which levels are occupied by the thirty-fifth proton and forty-first neutron. In columns 1 and 2 of Table IV we have listed the possible neutron and proton configurations taken in pairs in such a way as to permit a resultant spin of 1 for the ground state of the odd — odd Br^{76} . In columns 3 and 4 are listed the numbers that identify the appropriate Nilsson states, and in column 5 is listed the magnetic moment calculated by the use of the Nilsson wavefunctions. The calculations

TABLE IV

Magnetic moment of Br^{76} calculated using Nilsson wavefunctions
with deformation $\delta = 0.3$.

Proton	Neutron	Nilsson state numbers		μ_{calc} (nm)	μ_{exp} (nm) Abs. values
		Proton	Neutron		
$p_{3/2}^-$	$f_{5/2}^-$	16	15	-0.49	0.548
$f_{7/2}^-$	$g_{5/2}^+$	10	22	2.34	
$f_{7/2}^-$	$f_{5/2}^-$	10	15	3.99	
$g_{1/2}^+$	$d_{1/2}^+$	24	30	1.28	
$p_{3/2}^-$	$d_{1/2}^+$	16	30	0.40	
$p_{3/2}^-$	$g_{5/2}^+$	16	22	-2.15	

have been performed by evaluating the expression

$$\mu = \frac{1}{I+1} \langle \vec{\mu}_{op} \cdot \vec{I} \rangle \quad (16)$$

in the strong-coupling limit.

$$\vec{\mu}_{op} = g_s^p \vec{S}_p + g_s^n \vec{S}_n + g_l^p \vec{L}_p + g_l^n \vec{L}_n + g_R \vec{R}$$

The quantities $g_s^p = 5.585$ and $g_s^n = -3.826$ are the proton and neutron spin g factors, and $g_l^p = 1$, $g_l^n = 0$ are the orbital g factors. The quantities \vec{S}_p , \vec{S}_n , \vec{L}_p , \vec{L}_n , and \vec{R} are respectively the proton and neutron spin and orbital angular momentum, \vec{R} is the rotational angular momentum of the core, and $g_R = \frac{Z}{A} = 0.46$ is the core rotational g factor. Equation (16) is easily evaluated by using the matrix elements given by Nilsson.

It is now known that for large deformations, positive quadrupole moments tend to predominate.²⁵ It is likely, therefore, that the sign of $\mu(\text{Br}^{76})$ is negative. Of the two configurations exhibiting a negative moment in Table IV, the configuration $(pn) = (p_{3/2}^-, f_{5/2}^-)$ seems most likely. A measurement of the magnetic moment of Se^{75} would shed light on this matter.

ACKNOWLEDGMENTS

This work was greatly aided by the help of the Health Chemistry Division of the Lawrence Radiation Laboratory, particularly by Mr. Homer Adams. Mr. John Padilla assisted in taking data and in the many calculations involved in the data processing.

The first two named authors would like to acknowledge an interesting and very helpful discussion concerning the interpretation of the measurements with Professor Ben Mottelson.

REFERENCES

1. Garvin, Green, Lipworth, and Nierenberg, *Phys. Rev. Lett.* 1, 293 (1958).
2. Green, Garvin, and Lipworth, *Bull. Am. Phys. Soc., Ser. II*, 3, 318 (1958).
3. N. F. Ramsey, Molecular Beams (Oxford University Press, London, 1956), Chap. 9.
4. For a general description of the method of atomic beams as applied to radioactive atoms, see William A. Nierenberg, *Ann. Revs. Nucl. Sci.* 7, 349 (1957).
5. Garvin, Green, Lipworth, and Nierenberg, *Hyperfine Structure and Nuclear Moments of Bromine-82*, UCRL-8680, March 9, 1959; to be published in *Physical Review*.
6. S. A. Gordon, *Rev. Sci. Inst.* 29, 501 (1958).
7. Garvin, Green, and Lipworth, *Phys. Rev.* 111, 534 (1958).
8. S. C. Fulz and M. L. Pool, *Phys. Rev.* 86, 347 (1952).
9. S. Thulin, *Arkiv Fysik* 9, 137 (1955).
10. For a discussion of the use of the χ^2 significance test, see reference 5 and R. A. Fisher, Statistical Methods for Research Workers (Oliver and Boyd, London 1948).
11. H. B. G. Casimir, On the Interaction Between Atomic Nuclei and Electrons (Teylers Tweede Genootschap, Haarlem 1936), pp. 57 and 58.
12. Davis, Feld, Zabel, and Zacharias, *Phys. Rev.* 76, 1076 (1949).
13. H. Kopfermann, Nuclear Moments (Academic Press, Inc., New York, N. Y., 1958) pp. 445 and 448.

14. J. G. King and V. Jaccarino, *Phys. Rev.* 94, 1610 (1954).
15. H. E. Walchli, Some Improved Measurements of Nuclear Magnetic Dipole Moments by Means of Nuclear Magnetic Resonance, ORNL-1775, October 1954.
16. R. E. Sternheimer, *Phys. Rev.* 86, 316 (1952).
17. R. E. Sternheimer, *Phys. Rev.* 95, 736 (1954).
18. H. B. G. Casimir, On the Interaction Between Atomic Nuclei and Electrons (Teylers Tweede Genootschap, Haarlem, 1936) pp. 55.
19. R. G. Barnes and W. V. Smith, *Phys. Rev.* 93, 95 (1954).
20. M. G. Mayer and J. H. D. Jensen, Elementary Theory of Nuclear Shell Structure (John Wiley and Sons, New York, N. Y., 1955).
21. The Spin of Br⁷⁷ has been recently reported by Green, Garvin, Lipworth, and Smith, *Bull. Am. Phys. Soc.* 4, 250 (1959).
22. L. C. Aamodt and P. C. Fletcher, *Phys. Rev.* 98, 1224 (1955).
23. R. J. Blin-Stoyle, Theories of Nuclear Moments (Oxford University Press, Oxford, 1957).
24. S. G. Nilsson, *Kgl. Danske-Videnskab. Selskab, Mat.-fys. Medd.* 29, No. 16 (1955).
25. B. R. Mottelson and S. G. Nilsson, *Danske Videnskab. Selskab, Mat.-fys. Skrifter* 1, No. 8 (1958).

FIGURE LEGENDS

- Fig. 1. Plot of hyperfine-level energy, W , (in units of a) vs b/a for $I=1$ and $J=3/2$.
- Fig. 2. Schematic representation of energy levels of Br^{76} as a function of magnetic field. (a) without level inversion and (b) with an inversion of $F=3/2$ and $F=1/2$ levels.
Allowed "flop-in" transitions are ($\alpha\beta\gamma$).
- Fig. 3. Apparatus used to separate Br^{76} from arsenic metal.
- Fig. 4. Demountable discharge tube used to dissociate bromine molecules.
- Fig. 5. Observed $l(\alpha)$ resonance at a field of 110.95 gauss.
- Fig. 6. Observed $l(\beta)$ resonance at a field of 17.07 gauss.
- Fig. 7. Observed $l(\gamma)$ resonance at a field of 6.9 gauss.
- Fig. 8. Plot of energy levels of Br^{76} versus magnetic field. The energies were obtained by solving the Hamiltonian with an I. B. M. 650 computer using a and b values close to the final results.

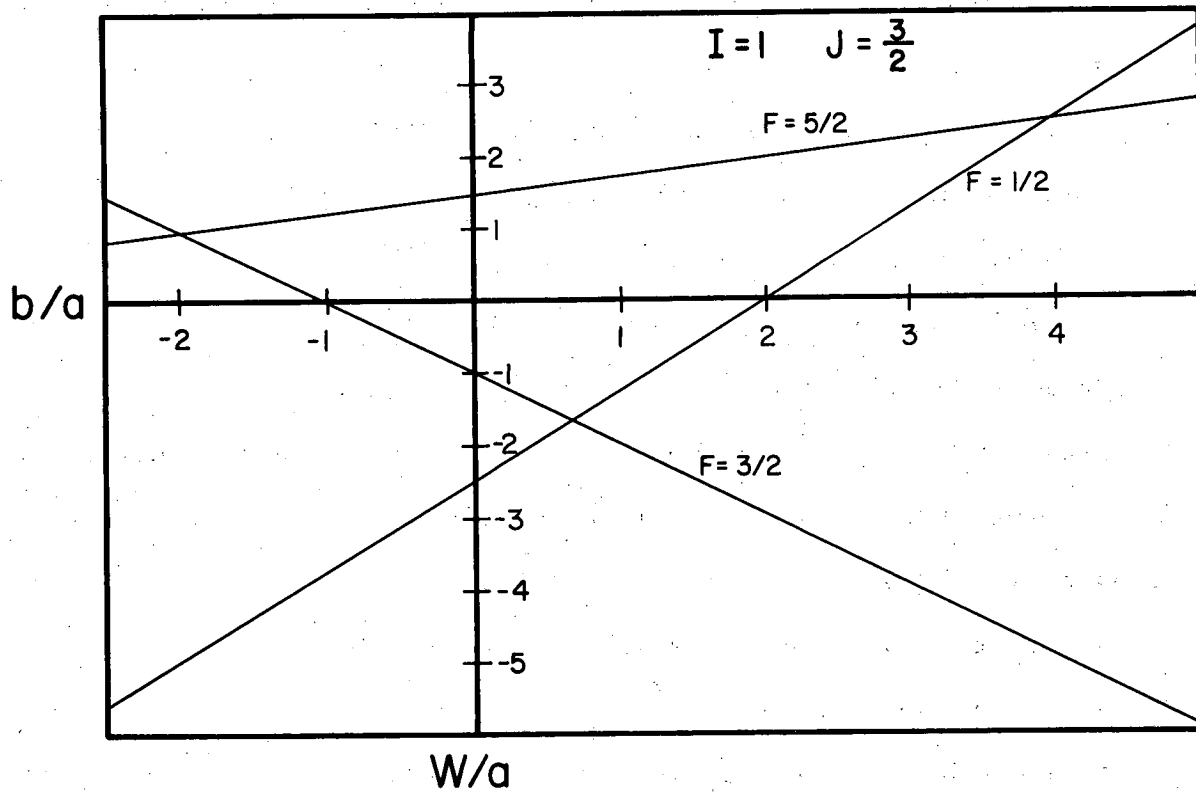

MU - 18956

Fig. 1

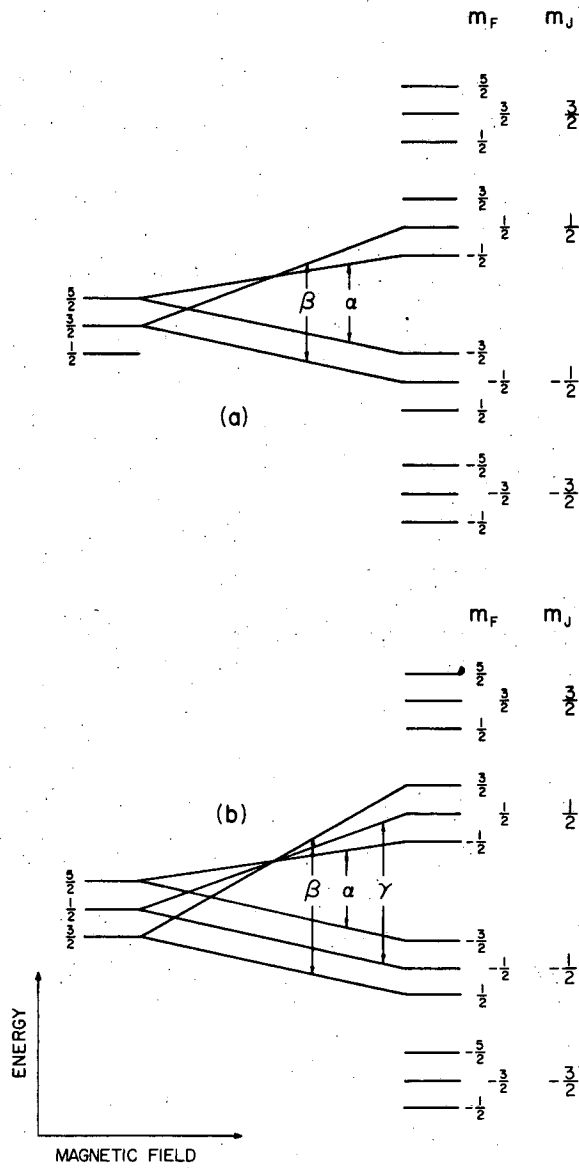

MU - 18957

Fig. 2

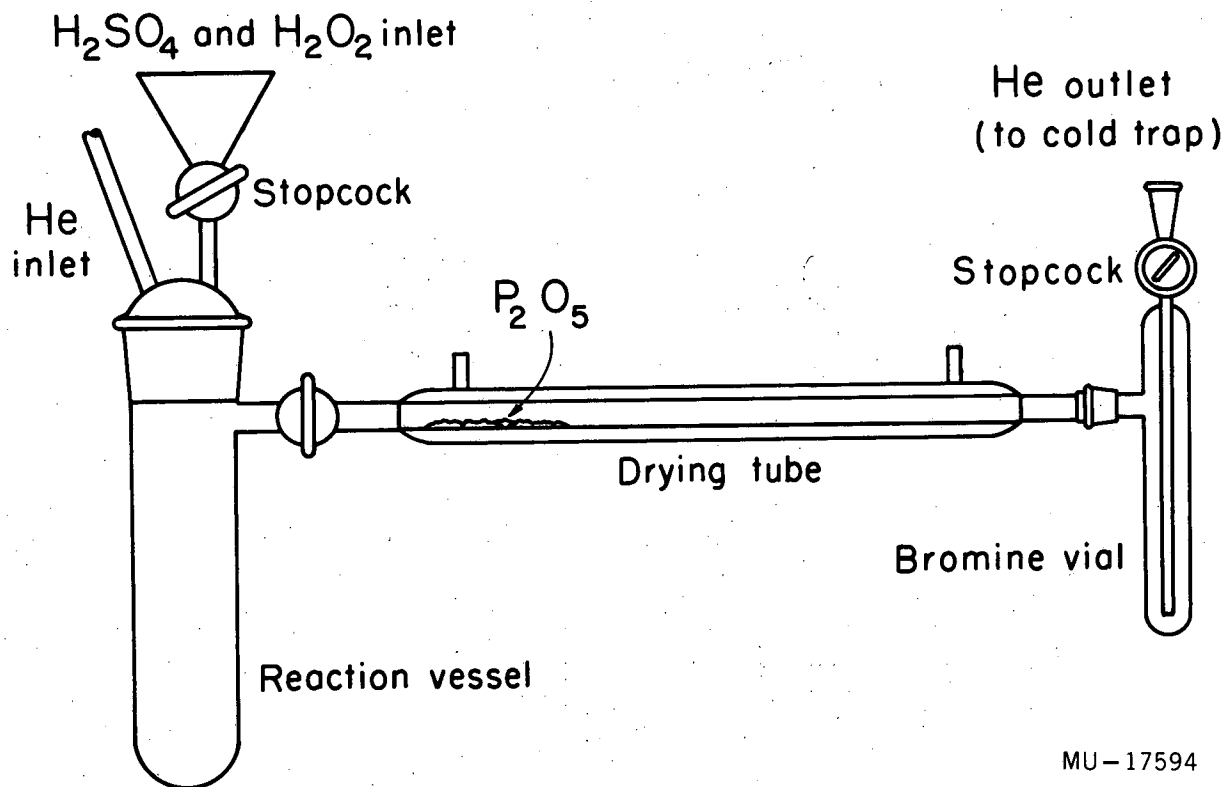

MU-17594

Fig. 3

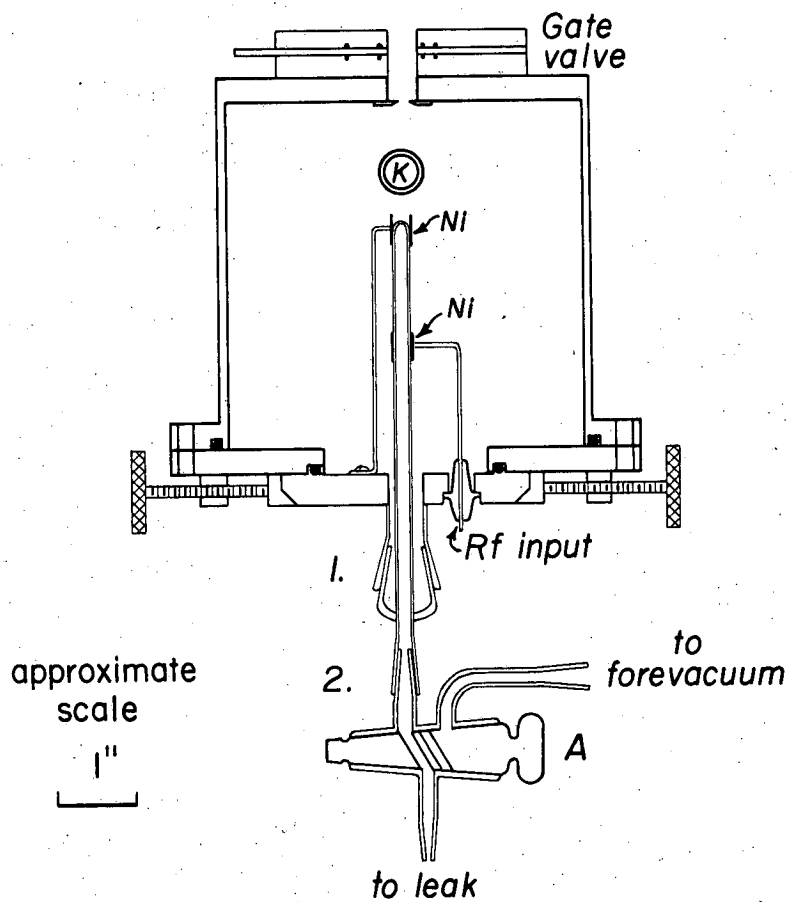

MU-17252

Fig. 4

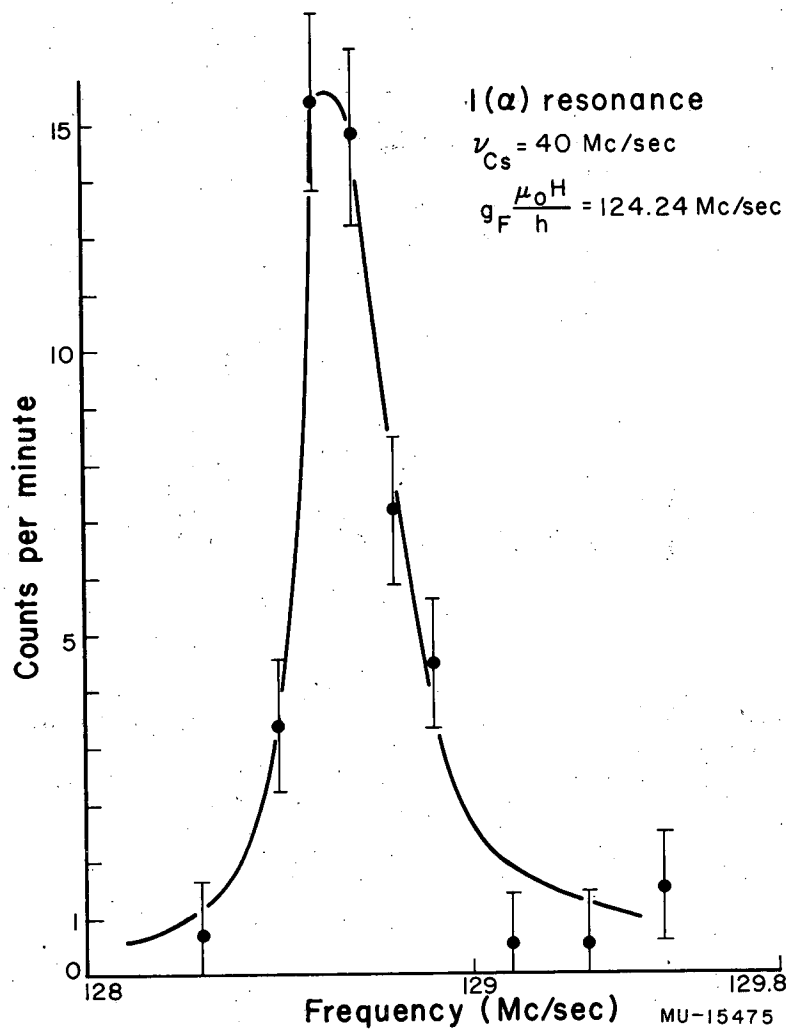

Fig. 5

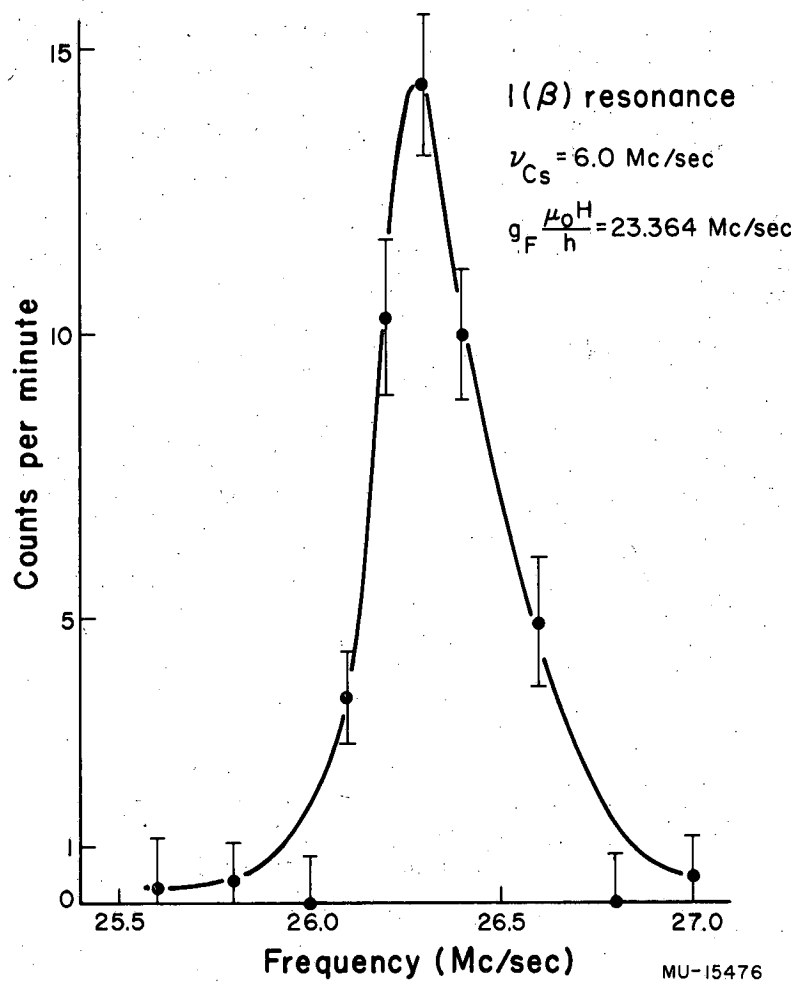
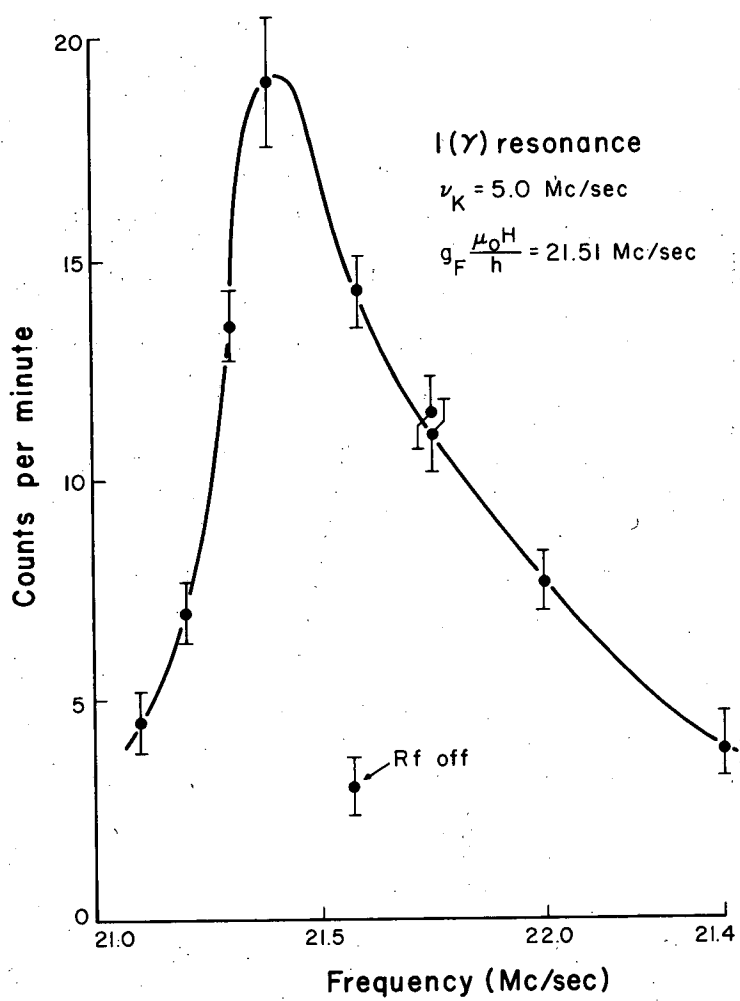
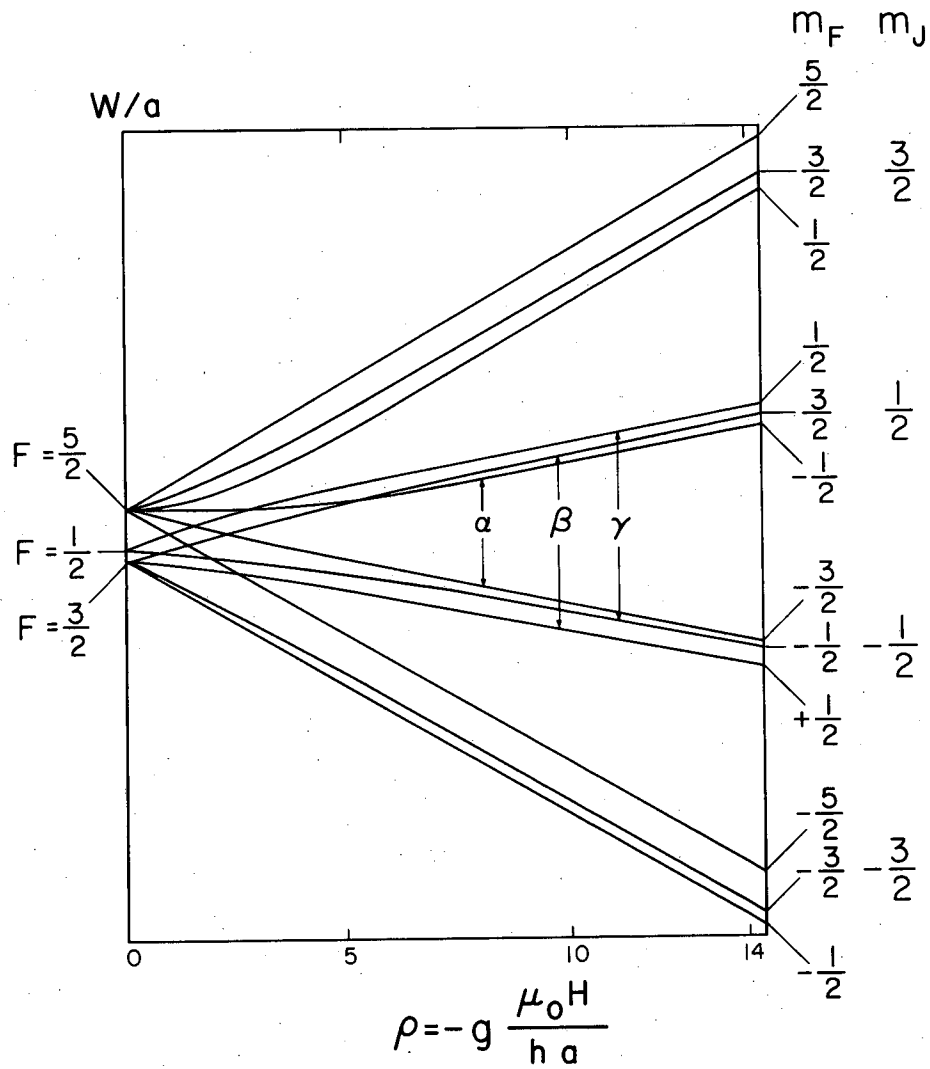

Fig. 6



MU-15796

Fig. 7



MU-18955

Fig. 8

This report was prepared as an account of Government sponsored work. Neither the United States, nor the Commission, nor any person acting on behalf of the Commission:

- A. Makes any warranty or representation, expressed or implied, with respect to the accuracy, completeness, or usefulness of the information contained in this report, or that the use of any information, apparatus, method, or process disclosed in this report may not infringe privately owned rights; or
- B. Assumes any liabilities with respect to the use of, or for damages resulting from the use of any information, apparatus, method, or process disclosed in this report.

As used in the above, "person acting on behalf of the Commission" includes any employee or contractor of the Commission, or employee of such contractor, to the extent that such employee or contractor of the Commission, or employee of such contractor prepares, disseminates, or provides access to, any information pursuant to his employment or contract with the Commission, or his employment with such contractor.