

# Lawrence Berkeley National Laboratory

## LBL Publications

### Title

Design of a Dedicated Heavy Ion Accelerator for Radiotherapy

### Permalink

<https://escholarship.org/uc/item/9fk4n7b4>

### Authors

Gough, R

Alonso, J

Elioff, T

et al.

### Publication Date

1983-03-01

c.2



# Lawrence Berkeley Laboratory

UNIVERSITY OF CALIFORNIA

RECEIVED  
LAWRENCE  
BERKELEY LABORATORY

## Accelerator & Fusion Research Division

MAY 17 1983

LIBRARY AND  
DOCUMENTS SECTION

Presented at the Particle Accelerator Conference  
on Accelerator, Engineering and Technology,  
Sweeney Convention Center, Santa Fe, NM,  
March 21-23, 1983

DESIGN OF A DEDICATED HEAVY ION ACCELERATOR  
FOR RADIOTHERAPY

R. Gough, J. Alonso, T. Elioff, J. Fugitt,  
A. Garren, H.A. Grunder, H. Lancaster, R. Sah,  
B. Sorensen, J. Staples, and R. Yourd

March 1983

### TWO-WEEK LOAN COPY

*This is a Library Circulating Copy  
which may be borrowed for two weeks.  
For a personal retention copy, call  
Tech. Info. Division, Ext. 6782.*

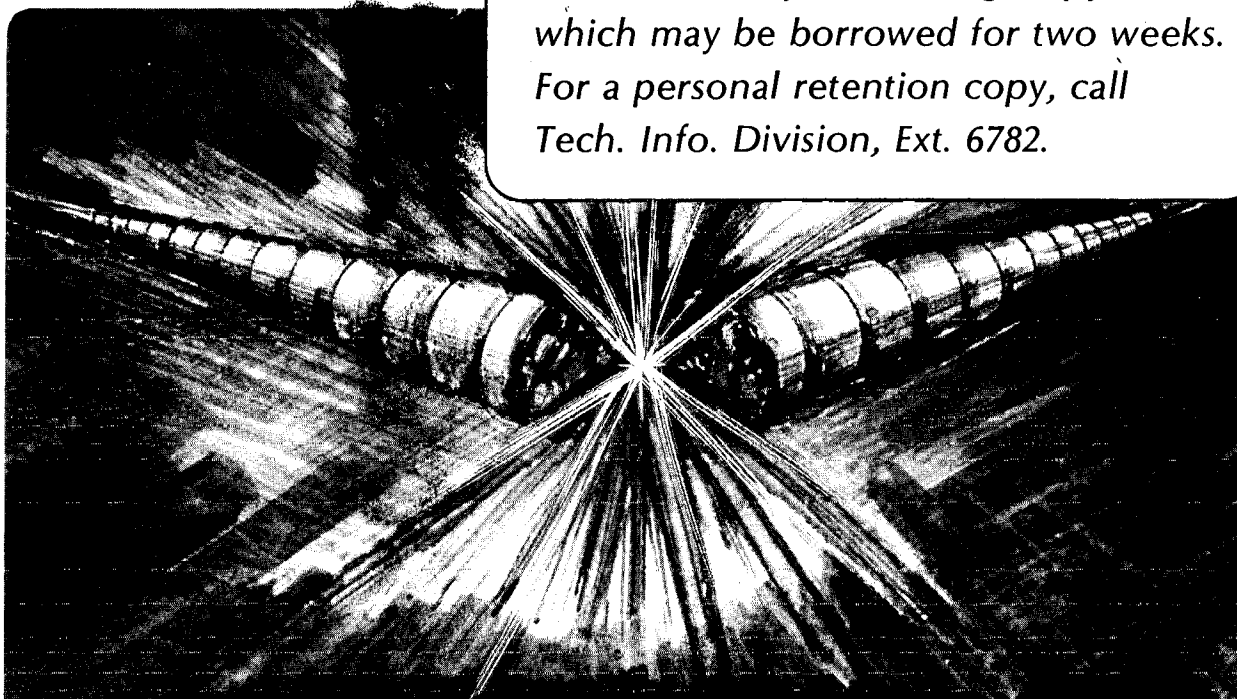

LBL-15147  
c.2

## **DISCLAIMER**

This document was prepared as an account of work sponsored by the United States Government. While this document is believed to contain correct information, neither the United States Government nor any agency thereof, nor the Regents of the University of California, nor any of their employees, makes any warranty, express or implied, or assumes any legal responsibility for the accuracy, completeness, or usefulness of any information, apparatus, product, or process disclosed, or represents that its use would not infringe privately owned rights. Reference herein to any specific commercial product, process, or service by its trade name, trademark, manufacturer, or otherwise, does not necessarily constitute or imply its endorsement, recommendation, or favoring by the United States Government or any agency thereof, or the Regents of the University of California. The views and opinions of authors expressed herein do not necessarily state or reflect those of the United States Government or any agency thereof or the Regents of the University of California.

## DESIGN OF A DEDICATED HEAVY ION ACCELERATOR FOR RADIOTHERAPY\*

R. Gough, J. Alonso, T. Elioff, J. Fugitt, A. Garren, H. A. Grunder, H. Lancaster  
R. Sah, B. Sorensen, J. Staples and R. Yourd

Lawrence Berkeley Laboratory  
University of California  
Berkeley, CA 94720

Summary

A new heavy ion accelerator facility for radiotherapy is being designed at the Lawrence Berkeley Laboratory. Performance requirements have been established. Ions from helium to argon can be accelerated to a maximum energy of 800 MeV/nucleon with intensities in the range  $10^8$ - $10^9$  particles per second. The accelerator subsystems consist of a linac injector, a synchrotron and a beam delivery system. Specifications have been developed for many of the technical components, and some details of the technical design are presented.

Introduction

A general description of the heavy ion medical accelerator now under design at LBL is given in reference 1. Ions ranging from helium to argon are accelerated to final energies from 100 to 800 MeV/n with intensities and beam characteristics suitable for radiotherapeutic treatment of large, and often deep-seated tumors. The overall design objectives are most economically met with an alternating gradient synchrotron. Because treatment times are short, typically 1 or 2 minutes, and patient set-up times are 20 to 30 minutes, the synchrotron can be efficiently switched between as many as 8 treatment rooms.

The unique challenge in the design of this accelerator is to provide flexibility in the choice of ion species and energies on a patient-to-patient basis, while at the same time providing an unusually high degree of reliability and operational simplicity. Minimizing staffing and other operational costs is also extremely important if heavy ion radiotherapy is to be made available at a hospital or major medical complex.

The design approach is first to provide multiple, independent ion sources each similar to the "dual-headed" sources at the ABEL injector at the SuperHILAC.<sup>(2)</sup> This redundancy is a highly cost effective means of providing the needed flexibility and reliability. Second, a high performance control system, described more fully in reference 3, addresses the issues of reliability and operational simplicity. It is similar to the control system recently developed for the ABEL injector.<sup>(4)</sup> It consists of a large number of distributed micro-processors to handle the I/O data, monitoring, control, and operator displays. A powerful mini-computer is incorporated to handle a variety of high level control functions including automated diagnostics and beam line tuning. Finally, conservative design practices are being followed throughout to ensure reliability of individual components.

Intensity Requirements

The intensity is specified by requiring that the prescribed dose can always be delivered to large treatment volumes in about one minute. For silicon

ions, a minimum intensity of  $2.6 \times 10^7$  ions/sec must be delivered to the patient. If this requirement is met for the silicon beam, it can readily be met for lighter ions. Beams heavier than silicon are not used in the treatment of large tumors, and consequently have substantially lower intensity requirements. Silicon has therefore been adopted as the design ion.

Table 1 gives the flux or instantaneous intensity for a silicon beam at critical points along the accelerator chain, working backward from the target. Best estimates for the transmission of major components are indicated. The source performance quoted has been obtained by Gavin.<sup>(5)</sup> The factor of two performance margin provided by the transmission efficiencies in Table 1 will allow the minimum acceptable dose to be delivered without optimum performance of all the accelerator systems. The nominal synchrotron rep rate is 2 Hz; however, it will be capable of operating at 4 Hz, providing twice the average flux. Also, a more advanced therapy beam preparation system such as one now under evaluation at LBL would improve the above quoted 10% efficiency by a factor of four.

Table 1: Silicon Intensity Schedule

Required $^{28}\text{Si}^{+14}$ ions on target	2.6 $10^7$ /sec
Machine rep rate	2 Hz
Therapy beam preparation	0.1
Extraction efficiency	0.75
Acceleration efficiency	1.0
R. F. capture efficiency	0.5
Injection efficiency (single turn)	0.9
Number of injected particles/pulse	3.8 $10^8$
Revolution time	2.34 microsec
Injected particle current	26 p micro amp
Injected electrical current	369 e micro amp
Transfer line (8 MeV/n)	0.6 (14+)
Poststripper linac (q/A=.30)	0.75
Stripper 1 (1.75 MeV/n)	0.39
Prestripper linac (q/A =.143)	0.9
RFQ preaccelerator	0.8
LEBT efficiency (8.4 keV/n)	0.8
Source ion	$\text{Si}^{+4}$
Source electrical current	1000 e micro amp
Source particle current	250 p micro amp
Proven source performance	500 p micro amp

Injector

The injector system must possess a high reliability and ease of operation suitable for siting in a hospital environment. A conservative design for the system has been adopted that also attempts to minimize the overall size.

The injector is comprised of a small number of ion sources, providing ions up through argon at  $q/A \geq .14$ , each on a 60 kV stand, followed by a 200 MHz RFQ

\*This work was supported by the U.S. Department of Energy under Contract No. DE-AC03-76SF00098, and in part by the National Cancer Institute, of the National Institutes of Health under grant No. CA19138.

structure which accelerates to 250 keV/n. The RFQ is followed by a 1.75 MeV/n prestripper Alvarez operating in the 2 beta lambda mode, a stripper, and an 8 MeV/n poststripper Alvarez operating in the beta lambda mode. Both Alvarez linacs also operate at 200 MHz. The beam is stripped once again before injection into the synchrotron. A momentum spread of no greater than  $\pm 0.25\%$  is obtained by a debuncher cavity located in the transfer line 10 m downstream of the linac. The total linac length is 25 m. Up to four individual ion sources may be accommodated.

Table 2: Linac Parameters

	RFQ	Prestripper	Poststripper	
Ion	Si+4	Si+4	Si+10	
Energy in	8	250	1750	keV/n
Energy out	250	1750	8000	keV/n
Length	2.5	10.4	11.1	m
No. cells	400	84	78	
Aperture rad	.2	.5-.8	1-1.25	cm
Focusing	ES	++--	++--	
Max B'L		52	47	k Gauss
Axial field		2.2	1.8-2.3	MV/m
Freq	200	200	200	MHz
Norm Accept	.05	.13	.4	pi cm-mr
Avg gap field		9.0-9.2	8.8	MV/m

The RFQ is essentially identical to one currently undergoing tests at LBL.<sup>(6)</sup> The Alvarez sections are conventional throughout. The peak RFQ power requirement is roughly .1 MW with a duty factor of 0.1%. The two Alvarez tanks require a total peak power of approximately 2 MW.

The RF system for the linacs consists of a separate power amplifier and drive chain for each cavity. This is needed for ease of control of the phase and gradient over the wide range required for acceleration of all of the required ions. The phase and gradient are computer controlled, and regulated by a control chassis identical to the unit developed for the Bevatron upgrade project.<sup>(6)</sup> This unit uses a unique phase control system to control the phase over a full 360 degree range.

### Synchrotron

#### Magnet Lattice Design

The synchrotron accelerates fully stripped beams from 8 to a maximum of 800 MeV/n and has a circumference of 91.8 m. To ensure ease of tuning, a separate function design is used and the periodicity is made as high as possible. The lattice consists of three superperiods of three cells each. Each cell consists of a D/2 O F O D/2 sequence with about a 90 degree phase advance. Three cells are assembled into a superperiod, with all straight sections except the second and fifth containing bends. Thus the lattice has six 4.7 m long straights and tune of 2.3. The basic periodicity is weakly three, with a stronger periodicity of order nine.

The 12 dipoles are each 3.2 meters long and operate at a maximum field of 1.593 T. The 18 quadrupoles are each .4 meters long and operate at a maximum gradient of 6.9 T/m with a 5 cm aperture radius.

The maximum beta functions, both radial and vertical, are less than 17 meters, and the maximum value of the off-momentum function is 5.4 meters. Assuming a normalized emittance of .15 pi cm-mrad, a momentum spread of  $\pm 0.4\%$  after r.f. turn-on, and orbit allowances of  $\pm 0.7$  cm radially and  $\pm 0.5$  cm vertically, the quadrupoles must have a 5.0 cm aperture radius. The magnet horizontal aperture requirement of  $\pm 4.5$  cm is established by the

extraction conditions; the  $\pm 1.9$  cm vertical magnet aperture is determined by the injection conditions. The good field of the magnet must extend to  $\pm 3.8$  cm.

Two families of three sextupoles are included to vary both the radial and vertical chromaticity of the machine. These sextupoles are located symmetrically at F- and D-quads, where there is substantial momentum dispersion. All of these elements are located in the 0.75 m short straight sections. Two families of six closed orbit correction modules are included, with an extra module located near the magnetic extraction septum. Each module consists of a beam induction electrode that senses both the x and y centroids of the circulating beam, and x and y deflecting dipoles with strengths of 60 gauss-meters.

#### Injection

In keeping with the philosophy to design for operational simplicity, a single-turn injection scheme has been adopted. This system consists of a magnetic septum 1.6 meters long followed by a ferrite-loaded fast kicker magnet .1 meters long, all contained within one straight section.

#### Extraction

As long spills up to 300 ms are required, resonant extraction is used. The extraction system consists of a .5 meter long electrostatic septum, followed by a 2 meter long magnetic septum approximately 90 degrees in phase advance downstream. Two sextupoles are included to produce the non-linearity and a fast quadrupole is included for finely adjusting the tune during extraction.

#### Dipole Magnet Power Supplies

The two operational modes at 2 and 4 Hz have duty factors and flat tops of 60 and 20%, and 300 and 50 ms respectively. In both cases the rise and fall times are 100 ms. This requires that the ring magnets go quickly to very low current and be ramped back on in a controlled fashion, all in 200 ms. It is desirable to transfer the large stored energy out of the bending magnets and return it to the magnets within 200 ms. It is proposed to accomplish this using a resonant capacitor energy storage system with a latched flat top auxiliary supply (see Figure 1). The SCR power supply at the left of the figure is

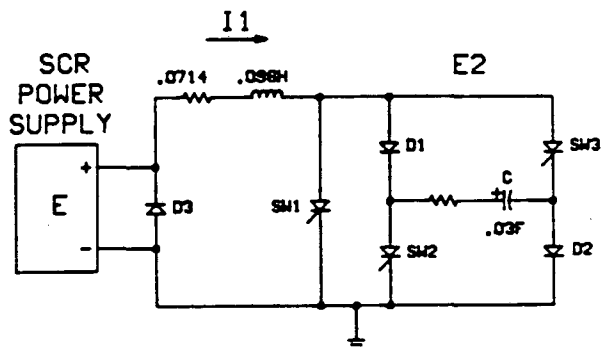

XBL 833-8810

Fig. 1: Schematic resonant energy storage system for 4 of the 12 synchrotron dipole magnets

used to compensate for energy losses and, during flat top, to regulate the current to about 0.05% with a ripple of 0.05%. Power is supplied by three such systems connected in series at every fourth magnet to reduce the voltage-to-ground at each magnet. Each of the three banks has a capacity of 0.05 farads and operating voltage of 3000 volts. They can be made of

many capacitors in parallel and arranged in rack modules for ease of assembly and maintenance.

### RF System

The synchrotron RF system must cover a frequency range of approximately 1 to 7 MHz (assuming second harmonic). This can be done with a ferrite-tuned cavity, using 4 cells, connected with the RF in series aiding, the bias turns in series, and the RF on the bias windings arranged to cancel. The disks of ferrite in this cavity are very close together which gives a high stacking factor, and reduces the total amount of ferrite required.

The RF power is provided by a pair of medium power tetrodes operating in push-pull, and connected to the external bias bussbar. It is possible to design the RF system with only a single tube in the output stage, but it is somewhat easier to design a broadband system if two smaller tubes are used. The power amplifier is operated as a linear amplifier in class B mode. Frequency and amplitude modulation are applied at a low level stage.

The RF driver is a commercial broad band solid state unit of a few KW output. These amplifiers are available from several manufacturers and are generally sold as communications amplifiers.

### Vacuum System

The Medical Accelerator has a main ring vacuum requirement of  $10^{-7}$  Torr. The whole vacuum system can be thought of as twelve nearly identical modules in a ring. The modules consist of vacuum chambers for one-half a quadrupole (100 mm x 0.5 m), a dipole (100 mm x 41 mm x 3.2 m), a quadrupole (100 mm x 1 m) and one-half a straight section (100 mm x 2.5 m). The dominant gas load is a function of surface area only. Water will be the dominant gas species of an unbaked vacuum system for the first few days after pumpdown. The ability of liquid-nitrogen cooled surfaces to pump water makes it possible to internally cryopump water at the entrances of the dipole and pump all other gases with external pumps. By placing 900 liter-per-second pumps for noncondensables in the middle of each straight section of the ring and a 95% efficient liquid nitrogen cryopump at each quadrupole, a satisfactory operating pressure distribution should occur after a few hours. The minimum volume for the accelerator vacuum chamber is about 1,000 liters. Using 2,000 liters as a reasonable upper limit, the roughing time to crossover for a 20 liter per second pump would be under 30 minutes. This roughing can be done at a single point in the system with only slightly longer roughing time than distributed roughing would offer.

### Therapy Beam Preparation

In order to provide radiation fields suitable for heavy ion radiotherapy, it is necessary to modify the spatial characteristics of external the beam. A beam size of 30 x 30 cm is often required in the treatment of large tumors, and must be provided with a uniformity of a few percent. The scattering foil-occluding ring technique presently in use at Harvard<sup>(7)</sup> and Berkeley<sup>(8)</sup> works well for lighter ion species but for heavier ions such as Ne, Si and Ar, the associated energy loss and beam contamination problems become more severe. For these beams a magnetic deflection system represents a more satisfactory solution. A system of two orthogonal dipole magnets, arranged to scan the beam in two dimensions, can not only provide cleaner beams with the required field size and uniformity, but also offers the potential for high resolution field definition and three dimensional scanning. Two fast-pulsed magnets have been built and recently

installed in the radiotherapy area at the Bevalac in order to evaluate this concept in a clinical setting.

### Radiation Shielding

Preliminary specifications have been developed for the radiation shielding required to provide a safe environment for the staff of the facility and the general public. A specific arrangement for the treatment rooms and shielding will depend on siting of the facility. It is assumed that a hospital setting in an urban area will be the preferred choice. In this case, it is recommended that the treatment rooms be located one level below grade to minimize shielding cost. Poured-in-place concrete is specified wherever feasible. The walls vary in thickness from 1.5 to 3 meters. A high density aggregate (3.6 g/cm<sup>3</sup>) is used to minimize the floor plan area. A lower cost, normal density (2.4 g/cm<sup>3</sup>) concrete is used for roof shielding. Access ports and cranes are provided for installation of heavy components inside the shielded enclosures.

### Conclusion

The goal of this effort is to complete a fully optimized design for a medical accelerator suitable for heavy ion radiotherapy and other biomedical applications. The general requirements and machine specifications are now well-defined. Engineering design of major components is proceeding and detailed cost estimates and construction schedules are being prepared. It is anticipated that the design effort will be completed by mid 1984.

### References

1. J. R. Alonso, T. E. Elioff, A. Garren, R. A. Gough, H. A. Grunder, H. Lancaster, S. Magyary, V. More, R. Sah, J. Staples and R. Yourd, "Advanced Medical Accelerator Design", Seventh Conference on the Application of Accelerators in Research and Industry, Denton, TX, Nov. 8-10, 1982.
2. B. Gavin, S. Abbott, R. MacGill, R. Sorensen, J. Staples, and R. Thatcher, "A High Current Pulsed Ion Source for Metallic Ions", IEEE Trans. Nucl. Sci. NS-28, 2684 (1981). Also LBL-II705.
3. S. Magyary, J. Glatz, H. Lancaster, F. Selph, M. Fahmie, A. Ritchie, C. Timossi, J. Hinckson, R. Benjegerdes, and D. Brodzik, "Operating Experience With a New Accelerator Control System Based Upon Microprocessors", IEEE Trans. Nucl. Sci. NS-28, 2201 (1981) Also LBL II724.
4. H. D. Lancaster S. Magyary and R. Sah, "A High Performance Control System for a Heavy Ion Accelerator", Particle Accelerator Conference, Santa Fe, NM (Mar 21-23, 1983).
5. B. Gavin, private communication
6. S. Abbott, D. Brodzik, R. A. Gough, D. Howard, H. Lancaster, R. MacGill, S. Rovnpera, H. Schneider, J. Staples and R. Yourd, "RFQ Development at LBL", Seventh Conference on the Application of Accelerators in Research and Industry, Denton, TX, Nov. 8-10, 1982.
7. A. M. Koehler, R. J. Schneider, J. M. Sisterson. "Flattening of Proton Dose Distributions for Large-field Radiotherapy. Med. Phys. 4, p. 297, (1977).
8. K. Crowe, L. Kanstein, J. Lyman and F. Yeater, "A Large Field Medical Beam at the 184-Inch Synchro-cyclotron", LBL Report No. 4235, (1975).

This report was done with support from the Department of Energy. Any conclusions or opinions expressed in this report represent solely those of the author(s) and not necessarily those of The Regents of the University of California, the Lawrence Berkeley Laboratory or the Department of Energy.

Reference to a company or product name does not imply approval or recommendation of the product by the University of California or the U.S. Department of Energy to the exclusion of others that may be suitable.

TECHNICAL INFORMATION DEPARTMENT  
LAWRENCE BERKELEY LABORATORY  
UNIVERSITY OF CALIFORNIA  
BERKELEY, CALIFORNIA 94720