

Lawrence Berkeley National Laboratory

Recent Work

Title

THEORY OF LOW-ENERGY NUCLEON-NUCLEON SCATTERING

Permalink

<https://escholarship.org/uc/item/9c86c622>

Authors

Goldberger, M.L.

Grisaru, M.T.

MacDowell, S.W.

et al.

Publication Date

1960-12-15

9634

Reprint 1961-121

Theory of Low-Energy Nucleon-Nucleon Scattering

M. L. GOLDBERGER, M. T. GRISARU, S. W. MACDOWELL, AND D. Y. WONG

TWO-WEEK LOAN COPY

*This is a Library Circulating Copy
which may be borrowed for two weeks.
For a personal retention copy, call
Tech. Info. Division, Ext. 5545*

Reprinted from THE PHYSICAL REVIEW, Vol. 120, No. 6, pp. 2250-2276, December 15, 1960

DISCLAIMER

This document was prepared as an account of work sponsored by the United States Government. While this document is believed to contain correct information, neither the United States Government nor any agency thereof, nor the Regents of the University of California, nor any of their employees, makes any warranty, express or implied, or assumes any legal responsibility for the accuracy, completeness, or usefulness of any information, apparatus, product, or process disclosed, or represents that its use would not infringe privately owned rights. Reference herein to any specific commercial product, process, or service by its trade name, trademark, manufacturer, or otherwise, does not necessarily constitute or imply its endorsement, recommendation, or favoring by the United States Government or any agency thereof, or the Regents of the University of California. The views and opinions of authors expressed herein do not necessarily state or reflect those of the United States Government or any agency thereof or the Regents of the University of California.

Theory of Low-Energy Nucleon-Nucleon Scattering*

M. L. GOLDBERGER

Palmer Physical Laboratory, Princeton University, Princeton, New Jersey

M. T. GRISARU

University of Illinois, Urbana, Illinois

S. W. MACDOWELL†

Palmer Physical Laboratory, Princeton University, Princeton, New Jersey

AND

D. Y. WONG

Lawrence Radiation Laboratory, University of California, Berkeley, California

(Received August 15, 1960)

The two-nucleon problem is discussed from the standpoint of the double dispersion relations. The analytic structure of partial wave amplitudes is completely analyzed. This is greatly facilitated by the use of the Jacob-Wick helicity amplitudes. The program of generating a set of dynamical equations by use of the unitarity condition is carried out. In the present approximation only one- and two-pion exchanges are considered; the resulting system of equations should be adequate for energies below about 170 Mev. The problem of computing the deuteron parameters is discussed. The general structure of the more complicated nucleon-antinucleon system is briefly treated.

I. INTRODUCTION

THE last ten years have witnessed a considerable change in the philosophy underlying the discussion of the two-nucleon problem. Whereas in the years following Yukawa's original work the emphasis had been on calculating a potential which could be used in conjunction with a Schrödinger equation, and although vestiges of this philosophy still can be found in the literature and in our way of thinking about the problem, it has become evident that such an approach is, even if reasonable, not very useful. The two-nucleon system is basically a relativistic one, even at moderate energies, and a potential approach cannot hope to give more than a qualitative description of the phenomena. In all fairness, however, it should be realized that the main reason for rejecting this approach has been our inability to calculate a reasonable potential, or even define it.

Ultimately, the theoretical handling of the problem has a two-fold goal. On one hand, we wish to use it as a testing ground for our ideas about the pion-nucleon interaction and the formalism of field theory. On the other, we would like to have a theoretical framework for analyzing and summarizing the existing experimental data. We are still very far from being able to predict the outcome of experiments not yet performed, and at present we must contend ourselves with deriving relations between known quantities. In this sense, we would like to think of the masses of elementary particles and coupling constants as being fundamental, and try to express other quantities, such as scattering lengths and

phase shifts in terms of them. This is already a formidable task.

In recent years, the dispersion theoretical approach has successfully dealt with a variety of processes, but the dispersion relations as applied to scattering have had only limited usefulness. One serious drawback of this approach is due to the fact that they cannot supply us with any information about the momentum transfer properties of scattering amplitudes. Related to this difficulty is the circumstance that one cannot conveniently make use of the information contained in the unitarity condition. Without unitarity, it seems very unlikely that the dispersion relations could be used, even if only in principle, as dynamical equations for the determination of scattering parameters.

The dispersion-theoretic handling of the two nucleon problem has been initiated by Goldberger, Nambu, and Oehme,¹ and the formal apparatus developed by these authors. The problem is considerably complicated by the presence of spin, but leaving aside essentially algebraic questions, one still runs into difficulties because of the extensive unphysical region which exists even for forward scattering. Nevertheless, the dispersion equations can be used to give an independent means of determining the pion-nucleon coupling constant, and do provide some information about the scattering process.

Recently, Mandelstam² has proposed a two-dimensional representation of scattering amplitudes which has many attractive features. If correct, this representation allows one to obtain some information about the momentum transfer properties of these amplitudes. Also, it allows one to derive dispersion relations for the

* Supported in part by the U. S. Atomic Energy Commission, Office of Naval Research, and the Air Force Office of Scientific Research, Air Research and Development Command.

† On leave of absence from Centro Brasileiro de Pesquisas Físicas, Rio de Janeiro, Brazil.

¹ M. L. Goldberger, Y. Nambu, and R. Oehme, *Ann. Phys.* **2**, 726 (1957). This paper will be referred to hereafter as G.N.O.

² S. Mandelstam, *Phys. Rev.* **112**, 1344 (1958); **115**, 1741 (1959); **115**, 1752 (1959).

partial wave amplitudes for which the unitarity condition takes a very simple form. It would seem that in principle this representation provides a full dynamical scheme for the discussion of scattering, and we would hope it would allow us, in spite of the approximations we must make, to obtain many quantitative features of the two-nucleon system.

Since much of the following deals with algebraic difficulties that have little to do with physics, we shall briefly summarize the contents of this paper. The work is fairly self-contained, but we assume that the reader is familiar with the main results of G.N.O., the recent literature on the Mandelstam representation, and the general approach of dispersion theory.³

We must deal not only with nucleon-nucleon scattering, but nucleon-antinucleon scattering as well. For each process, the Feynman amplitude can be expressed in terms of five invariant functions of the energy and the momentum transfer. In Sec. II we choose a convenient set of such functions, investigate the restrictions imposed upon them by the Pauli principle, and finally show that the amplitudes for nucleon-nucleon and nucleon-antinucleon scattering are connected by the so-called crossing relations, which we derive. In Sec. III we state the analyticity properties of these functions, in accordance with Mandelstam's hypothesis, and write down two-dimensional representations for them. We then relate the weight functions which appear in these representations to the absorptive parts of the amplitudes, which arise in the usual dispersion relations.

Section IV is devoted to a discussion of the partial wave decomposition of the scattering amplitudes, using the formalism recently developed by Jacob and Wick.⁴ In Sec. V we discuss the analyticity properties of the partial wave amplitudes, and write dispersion relations for them. In Sec. VI we collect the information that is available about the contributions to the absorptive parts of the low-mass intermediate states. We give the exact one-pion contribution, an approximation form of the two-pion contribution, and also write down the deuteron pole term.

In Sec. VII we show how the dispersion relations for the low angular momentum amplitudes can be solved. Unitarity, which we use in an approximate form by neglecting inelastic scattering, plays an important role in our approach. Finally, we discuss the deuteron bound state and show that in principle one might hope to calculate the binding energy and some other parameters that characterize it. A special method of solving the integral equations one obtains is given in Appendix C, making use of a variational principle.

³ After the completion of this paper we received a preprint of a paper with the same title by Amati, Leader, and Vitale, which covers some of the same material treated here. For completeness, we have not attempted to suppress our own presentation of the topics discussed by those authors.

⁴ M. Jacob and G. C. Wick, *Ann. Phys.* **7**, 404 (1959).

II. KINEMATICAL PRELIMINARIES AND CROSSING RELATIONS

The kinematics and crossing relations for the two-nucleon system have been treated in detail by G.N.O. However, the results of these authors cannot be conveniently used in conjunction with the Mandelstam representation and in dealing with identical particles. We shall, therefore, discuss the problem from the beginning, in a way which is more suitable for our treatment of the subject.

We must consider simultaneously the three processes

$$\begin{aligned} N_1 + N_2 &\rightarrow N_1' + N_2', & \text{(I)} \\ N_1 + \bar{N}_2 &\rightarrow N_1' + \bar{N}_2', & \text{(II)} \\ N_1 + \bar{N}_2 &\rightarrow \bar{N}_1' + N_2', & \text{(III)} \end{aligned} \quad (2.1)$$

where the bars designate antiparticles. Let the particles with subscript 1 have initial and final four-momenta P_1 and P_1' , respectively, those with subscript 2, P_2 and P_2' . We define three scalar variables

$$\begin{aligned} s &= -(P_1 + P_2)^2 = -(P_1' + P_2')^2, \\ \bar{t} &= -(P_1 - P_2')^2 = -(-P_2 + P_1')^2, \\ t &= -(P_1 - P_1')^2 = -(-P_2 + P_2')^2, \end{aligned} \quad (2.2)$$

which are related by $s + t + \bar{t} = 4m^2$, m being the nucleon mass (we use the scalar product $A \cdot B = \mathbf{A} \cdot \mathbf{B} + A_4 B_4 = \mathbf{A} \cdot \mathbf{B} - A_0 B_0$). For each of the three processes, s is the square of the total energy in the center-of-mass system, $-t$ and $-\bar{t}$ the squares of the momentum transfers for the pairs (1,1) and (1,2), respectively.

It is convenient to describe the reactions (I-III) using the formalism of isotopic spin. We assume charge independence holds rigorously and thereby neglect Coulomb effects and mass differences. Parity conservation and time reversal invariance are assumed throughout. It is then a simple matter to show that for each total isotopic spin state, five independent amplitudes are required for a complete characterization of nucleon-nucleon or nucleon-antinucleon scattering.

Consider first reaction (I), which may take place in either isotopic spin state 0 or 1. It is sufficient to discuss the situation for a given value of the total angular momentum J . The two-nucleon system can be either in a spin singlet or spin triplet state. We observe that there can be no transitions between the two spin states since, with our assumption of charge independence, for a given isotopic spin I singlet and triplet states of given J have opposite parities, as required by the Pauli principle. For the singlet state $J=l$ the orbital angular momentum, and one amplitude is sufficient to characterize the scattering process. With the system in a triplet state, we have $l=J$ or $l=J\pm 1$. For $l=J$, again one amplitude is sufficient, since parity conservation forbids transitions to $l=J\pm 1$, while for $l=J\pm 1$ three amplitudes are required, to describe the transitions $J+1 \rightarrow J-1$, $J-1 \rightarrow J-1$, and $J-1 \rightleftharpoons J+1$, respectively. (Time reversal invariance implies that the amplitudes

partial fraction decomposition of the term involving $\bar{\rho}_{12}^i$:

$$\begin{aligned} \bar{F}_i(s, \bar{l}, t) = & \int_{4\mu^2}^{\infty} \frac{ds'}{\pi} \int_{4\mu^2}^{\infty} \frac{d\bar{l}'}{\pi} \frac{\bar{\rho}_{13}^i(s', \bar{l}')}{(s'-s)(\bar{l}'-\bar{l})} \\ & + \int_{4\mu^2}^{\infty} \frac{ds'}{\pi} \int_{4m^2}^{\infty} \frac{d\bar{l}'}{\pi} \frac{\bar{\rho}_{12}^i(s', \bar{l}')}{(s'-s)(\bar{l}'+s'-s-\bar{l})} \\ & + \int_{4m^2}^{\infty} \frac{d\bar{l}'}{\pi} \int_{4\mu^2}^{\infty} \frac{d\bar{l}''}{\pi} \frac{\bar{\rho}_{23}^i(\bar{l}', \bar{l}'')}{(\bar{l}'-\bar{l})(\bar{l}''-\bar{l})} \\ & + \int_{4\mu^2}^{\infty} \frac{ds'}{\pi} \int_{4m^2}^{\infty} \frac{d\bar{l}'}{\pi} \frac{\bar{\rho}_{12}^i(s', \bar{l}')}{(s'-s)(\bar{l}'+s'-s-\bar{l})} + \bar{B}_i(s, \bar{l}, t). \end{aligned} \quad (3.a)$$

Comparison of the discontinuity across the positive s axis with the corresponding one in (3.3) leads to the identification

$$\bar{A}_i(s, \bar{l}) = \int_{4\mu^2}^{\infty} \frac{d\bar{l}'}{\pi} \frac{\bar{\rho}_{13}^i(s, \bar{l}')}{\bar{l}'-\bar{l}} + \int_{4m^2}^{\infty} \frac{d\bar{l}''}{\pi} \frac{\bar{\rho}_{12}^i(s, \bar{l}'')}{\bar{l}''-\bar{l}}. \quad (3.b)$$

It is slightly more convenient to write the equation for $\bar{A}_i(\bar{l}, t)$, by which we understand the absorptive amplitude \bar{A}_i with the energy variable being numerically equal to \bar{l} . This means that in the last term $\bar{l}=4m^2-s-\bar{l} \rightarrow 4m^2-\bar{l}-t=s$; we also change the name of the variable of integration in (3.6) to s' and write finally

$$\bar{A}_i(\bar{l}, t) = \int_{4\mu^2}^{\infty} \frac{ds'}{\pi} \frac{\bar{\rho}_{13}^i(\bar{l}, s')}{\bar{l}-s'} + \int_{4m^2}^{\infty} \frac{ds'}{\pi} \frac{\bar{\rho}_{12}^i(\bar{l}, s')}{s'-s}, \quad (3.c)$$

which is Eq. (3.9).

In a similar fashion, by looking for the discontinuity across the \bar{l} axis we find, by comparing the last two terms of (3.a) with the second term of (3.8),

$$\Omega_{ik} A_k(\bar{l}, t) = \int_{4\mu^2}^{\infty} \frac{d\bar{l}'}{\pi} \frac{\rho_{23}^i(\bar{l}, \bar{l}')}{\bar{l}'-\bar{l}} + \int_{4\mu^2}^{\infty} \frac{ds'}{\pi} \frac{\bar{\rho}_{12}^i(s', \bar{l})}{s'-s}. \quad (3.d)$$

In this equation \bar{l} represents the numerical value of the square of the energy for reaction (I). Again it is convenient to change the name of the variables, which leads to Eq. (3.11) of the main text, after making use of (3.6).

One further relation can be obtained, which involves the absorptive amplitude for reaction (III). We can avoid explicit introduction of this amplitude by using the Pauli principle. We recall that

$$F_j(s, \bar{l}, t) = (-1)^{j+1} F_j(s, t, \bar{l}) = K_{ji} F_i(s, t, \bar{l}), \quad (3.e)$$

where K denotes the combined matrix elements $(-1)^{j+1} \delta_{ij} \delta_{\Pi}$. From the one-dimensional dispersion relation (3.7) we have

$$F_j(s, \bar{l}, t) = K_{ji} \left[\int_{4m^2}^{\infty} \frac{ds'}{\pi} \frac{A_i(s', \bar{l})}{s'-s} + \int_{4\mu^2}^{\infty} \frac{d\bar{l}'}{\pi} \frac{\Omega_{ik} \bar{A}_k(\bar{l}', \bar{l})}{\bar{l}'-\bar{l}} + B_i(s, \bar{l}, t) \right], \quad (3.f)$$

where we have changed the variable of integration from \bar{l}' to \bar{l}' in the second term. Again, we make a partial fraction decomposition in (3.3), namely

$$\begin{aligned} F_j(s, \bar{l}, t) = & \int_{4m^2}^{\infty} \frac{ds'}{\pi} \int_{4\mu^2}^{\infty} \frac{d\bar{l}'}{\pi} \frac{\rho_{12}^i(s', \bar{l}')}{(s'-s)(\bar{l}'-\bar{l})} \\ & + \int_{4m^2}^{\infty} \frac{ds'}{\pi} \int_{4\mu^2}^{\infty} \frac{d\bar{l}'}{\pi} \frac{\rho_{13}^i(s', \bar{l}')}{(s'-s)(s'+\bar{l}'-s-\bar{l})} \\ & + \int_{4\mu^2}^{\infty} \frac{d\bar{l}'}{\pi} \int_{4\mu^2}^{\infty} \frac{d\bar{l}''}{\pi} \frac{\rho_{23}^i(\bar{l}', \bar{l}'')}{(\bar{l}'-\bar{l})(\bar{l}''-\bar{l})} \\ & + \int_{4m^2}^{\infty} \frac{ds'}{\pi} \int_{4\mu^2}^{\infty} \frac{d\bar{l}'}{\pi} \frac{\rho_{13}^i(s', \bar{l}')}{(\bar{l}'-\bar{l})(s'+\bar{l}'-s-\bar{l})} + B_i(s, \bar{l}, t). \end{aligned} \quad (3.g)$$

Comparing the second term in (3.7) with the last two integrals and making a change of variables, we are led to Eq. (3.12).

As is well known, the $A_j(s, t)$ are to be calculated by considering the absorptive part of the amplitude for reaction (I) and the $\bar{A}_j(s, t)$ are to be found from the absorptive part of the amplitude for reaction (II) [see G.N.O., Eq. (4.7), (4.7a); note the difference of factors of 2π , arising from our use of box rather than continuum normalization]. We have for \mathcal{Q}_I , the absorptive part

of reaction (I),

$$\begin{aligned} \mathcal{Q}_I(s, t) = & \pi \left(\frac{P_{20} P_{20}'}{m^2} \right)^{\frac{1}{2}} \sum_{n(P_n=P_1+P_2)} \bar{u}_\alpha(P_1') \langle P_2' | f_\alpha | n \rangle \\ & \times \langle n | f_\beta | P_2 \rangle u_\beta(P_1) (2P_{n0}) \delta[(P_1+P_2)^2 + m_n^2], \end{aligned} \quad (3.13)$$

where m_n is the "mass" of the intermediate state $|n\rangle$ and f, \bar{f} are defined by

$$\begin{aligned} (\gamma \partial / \partial x + m) \psi &= f, \\ (-\gamma^T \partial / \partial x + m) \bar{\psi} &= \bar{f}. \end{aligned} \quad (3.14)$$

The matrix elements in (3.13) are essentially those for the reactions $|P_1 P_2\rangle \rightarrow |n\rangle$ and $|P_1' P_2'\rangle \rightarrow |n\rangle$ so that, by nucleon number conservation $m_n^2 \geq 4m^2$ (apart from the bound deuteron state which we shall consider separately), which explains the lower limit of the first integral in (3.7) and the second in (3.8). Of course, (3.13) coincides with the usual statement of unitarity when s and t lie in the physical region; we assume the existence of an analytic continuation of \mathcal{Q}_I into the unphysical region. (This property has not been rigorously proven, but is true to all orders of perturbation theory provided that $-t < 4\mu^2$.) The individual A_j 's may be found by writing \mathcal{Q}_I in the form (2.3).

The corresponding quantities \bar{A}_j are to be obtained from the absorptive part \mathcal{Q}_{II} given by

$$\begin{aligned} \mathcal{Q}_{II}(s, t) = & \pi \left(\frac{P_{20} P_{20}'}{m^2} \right)^{\frac{1}{2}} \sum_{n(P_n=P_1+P_2)} \bar{u}_\alpha(P_1') \\ & \times \langle P_2' | (iC\tau_2 f)_\alpha | n \rangle \langle n | (iC^{-1}\tau_2 f)_\beta | P_2 \rangle \\ & \times (2P_{n0}) \delta[(P_1+P_2)^2 + m_n^2]. \end{aligned} \quad (3.15)$$

The states $|n\rangle$ included here have nucleon number zero. The lowest mass state that enters is the one pion state, which contributes to the Born term \bar{B} ; we have separated off this term explicitly. The next state is that of two pions, hence the minimum value of m_n^2 is $4\mu^2$. This corresponds to the process of nucleon-antinucleon annihilation into two pions which may be unphysical, when the energy of the pions is less than the physical minimum $4m^2$.

The use of (3.15) in the region $4\mu^2 < s < 4m^2$ in which the center-of-mass momentum $(s/4 - m^2)^{\frac{1}{2}}$ becomes imaginary, needs justification. The legitimacy of the procedure has been partially verified in perturbation theory,⁷ and we shall not question it. The manner in which \mathcal{Q}_{II} is evaluated in practice will be discussed later.⁸

IV. THE PARTIAL WAVE AMPLITUDES

For the study of the two-nucleon system at moderate energies, it is very useful to discuss the amplitudes for scattering in given angular momentum states, rather than the whole scattering amplitude. In addition to

⁷ M. T. Grisaru, Phys. Rev. **111**, 1719 (1958).

⁸ See reference 1, p. 247 and p. 266 for a discussion of these points; also M. L. Goldberger and R. Oehme (to be published).

various technical reasons, two main motives may be given: first, the partial wave approach allows easy contact with experimental data; second, the unitarity condition, which plays an important role in our discussion, takes a much simpler form for the partial wave amplitudes than for the whole scattering amplitude. Even if we did not have such motivation, it would be necessary to treat the low angular momentum states (at least the 3S state) separately, for mathematical reasons. The point is that, as was shown by Mandelstam,² when bound states or very strong interactions are present, subtractions are required in the representation for the F 's. The additional weight functions thus introduced cannot be determined by the unitarity condition for the whole amplitude. Instead, one must use the unitarity condition for individual angular momentum amplitudes; this will lead to integral equations for their determination, and for the determination of the bound-state energies. We shall devote this section to the expansion in partial wave amplitudes and in the next one, derive the dispersion relations that they satisfy.

The scattering process is described in the center-of-mass system by a matrix ϕ in spin space, defined in such a way that the differential cross section is given by

$$d\sigma/d\Omega = |\langle \lambda_1' \lambda_2' | \phi | \lambda_1 \lambda_2 \rangle|^2,$$

where λ_1', λ_2' represent the spin states of the outgoing nucleons, λ_1, λ_2 the spin states of the incoming nucleons. The matrix ϕ is a function of the total energy $W = 2E$ in the center-of-mass system (or the momentum \hat{p}), and of the scattering angle θ (or $z = \cos\theta$). These variables are related to those defined in (2.2) by

$$\begin{aligned} s &= W^2 = 4(\hat{p}^2 + m^2), \\ \bar{t} &= -2\hat{p}^2(1+z), \\ t &= -2\hat{p}^2(1-z). \end{aligned} \quad (4.1)$$

The connection between ϕ and the amplitude \mathcal{T}_1 defined in Sec. II is

$$\mathcal{T}_1 = 2\pi(W/m^2) \langle \lambda_1' \lambda_2' | \phi | \lambda_1 \lambda_2 \rangle. \quad (4.2)$$

It is convenient to express ϕ in terms of amplitudes for transitions in states of given quantum numbers for quantities which are constants of motion, such as total

angular momentum, parity and isotopic spin. In many problems the orbital angular momentum l is also conserved, but this is not the case for the two-nucleon system. Therefore, we have no particular reason for writing ϕ in terms of amplitudes for transitions in states of given l . Instead, we should take advantage of the intrinsic simplicity of the expansion of the scattering matrix in terms of amplitudes for transitions between states of given helicities, following the formalism developed by Jacob and Wick.⁹ We consider therefore such amplitudes as defined by these authors:

$$\langle \lambda_1' \lambda_2' | \phi | \lambda_1 \lambda_2 \rangle = - \frac{1}{\hat{p}} \sum_J (2J+1) \times \langle \lambda_1' \lambda_2' | T^J(W) | \lambda_1 \lambda_2 \rangle d_{\lambda\lambda'}^J(\theta), \quad (4.3)$$

where $d_{\lambda\lambda'}^J(\theta)$ is the reduced rotation matrix and $\lambda = \lambda_1 - \lambda_2, \lambda' = \lambda_1' - \lambda_2'$. Without any loss of generality we have set the azimuthal angle of the final momentum of particle 1 equal to zero.

As shown in Sec. II, if the interactions are invariant under space inversion, time reversal and rotations in isotopic spin space, nucleon-nucleon scattering in a given isotopic spin state is described by five independent amplitudes. For the helicity amplitudes, the invariance properties imply the following relations:

(i) Parity conservation

$$\langle \lambda_1' \lambda_2' | T^J(W) | \lambda_1 \lambda_2 \rangle = \langle -\lambda_1' -\lambda_2' | T^J(W) | -\lambda_1 -\lambda_2 \rangle, \quad (4.4)$$

(ii) Time reversal invariance

$$\langle \lambda_1' \lambda_2' | T^J(W) | \lambda_1 \lambda_2 \rangle = \langle \lambda_1 \lambda_2 | T^J(W) | \lambda_1' \lambda_2' \rangle, \quad (4.5)$$

(iii) Conservation of total spin

$$\langle \lambda_1' \lambda_2' | T^J(W) | \lambda_1 \lambda_2 \rangle = \langle \lambda_2' \lambda_1' | T^J(W) | \lambda_2 \lambda_1 \rangle. \quad (4.6)$$

(As pointed out in Sec. II, conservation of total spin follows from conservation of isotopic spin and parity.) Taking into account these symmetry properties and using the relations

$$d_{\lambda\mu}^J(\theta) = d_{-\lambda, -\mu}^J(\theta) = (-1)^{\lambda-\mu} d_{\mu\lambda}^J(\theta), \quad (4.7)$$

one can select the following set of five independent amplitudes:

$$\varphi_1 = \langle +\frac{1}{2} + \frac{1}{2} | \phi | +\frac{1}{2} + \frac{1}{2} \rangle = - \frac{1}{\hat{p}} \sum_J (2J+1) \langle +\frac{1}{2} + \frac{1}{2} | T^J(W) | +\frac{1}{2} + \frac{1}{2} \rangle d_{00}^J(\theta), \quad (4.8a)$$

$$\varphi_2 = \langle +\frac{1}{2} + \frac{1}{2} | \phi | -\frac{1}{2} - \frac{1}{2} \rangle = - \frac{1}{\hat{p}} \sum_J (2J+1) \langle +\frac{1}{2} + \frac{1}{2} | T^J(W) | -\frac{1}{2} - \frac{1}{2} \rangle d_{00}^J(\theta), \quad (4.8b)$$

$$\varphi_3 = \langle +\frac{1}{2} - \frac{1}{2} | \phi | +\frac{1}{2} - \frac{1}{2} \rangle = - \frac{1}{\hat{p}} \sum_J (2J+1) \langle +\frac{1}{2} - \frac{1}{2} | T^J(W) | +\frac{1}{2} - \frac{1}{2} \rangle d_{11}^J(\theta), \quad (4.8c)$$

$$\varphi_4 = \langle +\frac{1}{2} - \frac{1}{2} | \phi | -\frac{1}{2} + \frac{1}{2} \rangle = - \frac{1}{\hat{p}} \sum_J (2J+1) \langle +\frac{1}{2} - \frac{1}{2} | T^J(W) | -\frac{1}{2} + \frac{1}{2} \rangle d_{-11}^J(\theta), \quad (4.8d)$$

$$\varphi_5 = \langle +\frac{1}{2} + \frac{1}{2} | \phi | +\frac{1}{2} - \frac{1}{2} \rangle = - \frac{1}{\hat{p}} \sum_J (2J+1) \langle +\frac{1}{2} + \frac{1}{2} | T^J(W) | +\frac{1}{2} - \frac{1}{2} \rangle d_{10}^J(\theta). \quad (4.8e)$$

⁹ Reference 4; note a difference by a factor of 2 in our definition.

A convenient feature of these amplitudes from the point of view of analyticity is their symmetry under the transformation $W \rightarrow -W$, namely

$$\langle \lambda_1' \lambda_2' | \phi(W, z) | \lambda_1 \lambda_2 \rangle = (-1)^{\lambda' + \lambda + 1} \langle \lambda_1' \lambda_2' | \phi(-W, z) | \lambda_1 \lambda_2 \rangle, \quad (4.9)$$

which can be seen directly from Eqs. (4.17).

Our next step consists in relating the helicity amplitude φ_i to the covariant amplitudes F_j . We write the Dirac spinors, in the center-of-mass system as the direct product of Pauli spinors in the following way:

$$u_{\lambda 1} = \frac{1}{N} \begin{pmatrix} E+m \\ 2p\lambda_1 \end{pmatrix} \chi_{\lambda 1} \quad u_{\lambda' 1} = \frac{1}{N} \begin{pmatrix} E+m \\ 2p\lambda_1' \end{pmatrix} e^{-i\sigma_y \theta/2} \chi_{\lambda' 1}, \quad (4.10)$$

$$u_{\lambda 2} = \frac{1}{N} \begin{pmatrix} E+m \\ 2p\lambda_2 \end{pmatrix} \chi_{-\lambda 2} \quad u_{\lambda' 2} = \frac{1}{N} \begin{pmatrix} E+m \\ 2p\lambda_2' \end{pmatrix} e^{-i\sigma_y \theta/2} \chi_{-\lambda' 2},$$

where $N = [2m(E+m)]^{1/2}$, χ_{λ} is an eigenstate of $\frac{1}{2}\sigma_z$ with eigen value λ , and the representation is such that $\gamma_0 = \rho_3$, $\gamma = \rho_2 \sigma$, $\gamma_5 = -\rho_1$. We then compute the matrix elements

$$\bar{u}_{\lambda'} u_{\lambda} = (1/2m) [(E+m) - 4\lambda\lambda' (E-m)] \times (\chi_{\pm\lambda'} + e^{i\sigma_y \theta/2} \chi_{\pm\lambda}), \quad (4.11)$$

$$\bar{u}_{\lambda'} \gamma_5 u_{\lambda} = (p/m) (\lambda' - \lambda) (\chi_{\pm\lambda'} + e^{i\sigma_y \theta/2} \chi_{\pm\lambda}), \quad (4.12)$$

$$\bar{u}_{\lambda'} \gamma_5 \gamma_4 u_{\lambda} = (p/m) (\lambda' + \lambda) (\chi_{\pm\lambda'} + e^{i\sigma_y \theta/2} \chi_{\pm\lambda}), \quad (4.13)$$

$$\bar{u}_{\lambda'} \gamma_5 \gamma u_{\lambda} = -(i/2m) [(E+m) + 4\lambda\lambda' (E-m)] \times (\chi_{\pm\lambda'} + e^{i\sigma_y \theta/2} \sigma \chi_{\pm\lambda}), \quad (4.14)$$

where the appropriate sign is taken in $\chi_{\pm\lambda}$ and $\chi_{\pm\lambda'}$, i.e., positive for particle 1 and negative for particle 2. Finally,

$$\chi_{\lambda'} + e^{i\sigma_y \theta/2} \chi_{\lambda} = |\lambda' + \lambda| \cos(\theta/2) + (\lambda' - \lambda) \sin(\theta/2), \quad (4.15)$$

$$\chi_{\lambda'} + e^{i\sigma_y \theta/2} \sigma \chi_{\lambda} = (\lambda' + \lambda) [\epsilon_z \cos(\theta/2) + i(\lambda' + \lambda) \epsilon_y \sin(\theta/2) + \epsilon_x \sin(\theta/2)] - |\lambda' - \lambda| [\epsilon_z \sin(\theta/2) + i(\lambda' - \lambda) \epsilon_y \times \cos(\theta/2) + \epsilon_x \cos(\theta/2)], \quad (4.16)$$

where the ϵ 's are unit vectors along the three axes. (The explicit calculation of matrix elements other than $\bar{u}u$, $\bar{u}\gamma_5 u$, $\bar{u}\gamma_5 \gamma u$ can be avoided by using the relations $V + \bar{V} = S + \bar{S} - P - \bar{P}$, $T + \bar{T} = S + \bar{S} + P + \bar{P}$.) Using these results, we obtain the connection between the φ 's and the F 's:

$$4\pi\varphi_1 = (1/E) [m^2 \{F_1 + (F_2 + F_4) \cos\theta\} - (3E^2 + p^2) F_3], \quad (4.17a)$$

$$4\pi\varphi_2 = (1/E) [-E^2 F_1 + \{(E^2 + p^2) F_2 + m^2 F_4\} \cos\theta + 3m^2 F_3 - p^2 F_5], \quad (4.17b)$$

$$4\pi\varphi_3 = (1/E) [2m^2 F_2 + 2E^2 F_4 + p^2 (-F_1 + 2F_3 + F_5)] \times \cos^2(\theta/2), \quad (4.17c)$$

$$4\pi\varphi_4 = (1/E) [2m^2 F_2 + 2E^2 F_4 - p^2 (-F_1 + 2F_3 + F_5)] \times \sin^2(\theta/2), \quad (4.17d)$$

$$4\pi\varphi_5 = -m(F_2 + F_4) \sin\theta. \quad (4.17e)$$

We investigate now the restrictions imposed on the helicity amplitudes by the Pauli principle. From (4.17) and (2.9) it follows that

$$\varphi_1(\pi - \theta) = (-1)^{I+1} \varphi_1(\theta), \quad (4.18a)$$

$$\varphi_2(\pi - \theta) = (-1)^{I+1} \varphi_2(\theta), \quad (4.18b)$$

$$\varphi_3(\pi - \theta) = (-1)^I \varphi_4(\theta), \quad (4.18c)$$

$$\varphi_5(\pi - \theta) = (-1)^I \varphi_5(\theta). \quad (4.18d)$$

Using the relation

$$d_{\lambda\mu}^J(\theta) = (-1)^{J+\lambda} d_{\lambda-\mu}(\pi - \theta), \quad (4.19)$$

we deduce the following conditions, which are imposed by the Pauli principle on the helicity amplitudes in states of given J :

$$\langle +\frac{1}{2} + \frac{1}{2} | T^J(W) | \pm\frac{1}{2} \pm \frac{1}{2} \rangle = (-1)^{J+I+1} \langle +\frac{1}{2} + \frac{1}{2} | T^J(W) | \pm\frac{1}{2} \pm \frac{1}{2} \rangle, \quad (4.20a)$$

$$\langle +\frac{1}{2} - \frac{1}{2} | T^J(W) | +\frac{1}{2} - \frac{1}{2} \rangle = (-1)^{J+I+1} \langle +\frac{1}{2} - \frac{1}{2} | T^J(W) | -\frac{1}{2} + \frac{1}{2} \rangle, \quad (4.20b)$$

$$\langle +\frac{1}{2} + \frac{1}{2} | T^J(W) | +\frac{1}{2} - \frac{1}{2} \rangle = (-1)^{J+I+1} \langle +\frac{1}{2} + \frac{1}{2} | T^J(W) | +\frac{1}{2} - \frac{1}{2} \rangle. \quad (4.20c)$$

The helicity amplitudes we have introduced do not represent transitions in states of given parity and total spin; we shall introduce now amplitudes that do represent such transitions. In so doing we shall be able to get a better understanding of the above conditions. Let us first form the states of given parity, namely

$$(1/\sqrt{2}) (|J; +\frac{1}{2} + \frac{1}{2}\rangle \pm |J; -\frac{1}{2} - \frac{1}{2}\rangle), \quad (4.21a)$$

$$(1/\sqrt{2}) (|J; +\frac{1}{2} - \frac{1}{2}\rangle \pm |J; -\frac{1}{2} + \frac{1}{2}\rangle). \quad (4.21b)$$

Inspection of these states shows that the first one, (4.21a) taken with the minus sign is a singlet, while the others belong to the triplet state. Moreover, the states with the minus sign have orbital angular momentum $l=J$; indeed, they have the same parity and evidently $l=J$ for the singlet state. Therefore, the following transitions are possible, in states of given parity and total spin:

$$\text{Singlet: } f_0^J = \langle +\frac{1}{2} + \frac{1}{2} | T^J | +\frac{1}{2} + \frac{1}{2} \rangle - \langle +\frac{1}{2} + \frac{1}{2} | T^J | -\frac{1}{2} - \frac{1}{2} \rangle. \quad (4.22a)$$

$$\text{Triplet: } f_1^J = \langle +\frac{1}{2} - \frac{1}{2} | T^J | +\frac{1}{2} - \frac{1}{2} \rangle - \langle +\frac{1}{2} - \frac{1}{2} | T^J | -\frac{1}{2} + \frac{1}{2} \rangle. \quad (4.22b)$$

$$\text{Triplet } \left\{ \begin{array}{l} f_{11}^J = \langle +\frac{1}{2} + \frac{1}{2} | T^J | +\frac{1}{2} + \frac{1}{2} \rangle \\ \quad + \langle +\frac{1}{2} + \frac{1}{2} | T^J | -\frac{1}{2} - \frac{1}{2} \rangle \end{array} \right. \quad (4.22c)$$

$$\text{Triplet } \left\{ \begin{array}{l} f_{12}^J = 2 \langle +\frac{1}{2} + \frac{1}{2} | T^J | +\frac{1}{2} - \frac{1}{2} \rangle \\ f_{22}^J = \langle +\frac{1}{2} - \frac{1}{2} | T^J | +\frac{1}{2} - \frac{1}{2} \rangle \\ \quad + \langle +\frac{1}{2} - \frac{1}{2} | T^J | -\frac{1}{2} + \frac{1}{2} \rangle. \end{array} \right. \quad (4.22e)$$

The conditions (4.20) then imply the expected selection rules due to the Pauli principle, as shown in Table I.

It is now clear that one should look for such combina-

tions of the φ 's which yield uncoupled singlet and triplet amplitudes where from one can project out the partial wave amplitudes f^J . After some manipulation with the functions $d_{\lambda\mu}^J$, one finds that a simple set satisfying this requirement is

$$f_1 = E(\varphi_1 - \varphi_2) = E^2 G_1 - z p^2 G_2 + m^2 G_3, \quad (4.23a)$$

$$f_2 = E(\varphi_1 + \varphi_2) = (E^2 G_2 + m^2 G_4)z - p^2 G_5, \quad (4.23b)$$

$$f_3 = E\{[1/(1+z)]\varphi_3 - [1/(1-z)]\varphi_4\} = -p^2 G_3, \quad (4.23c)$$

$$f_4 = E\{[1/(1+z)]\varphi_3 + [1/(1-z)]\varphi_4\} \\ = m^2 G_2 + E^2 G_4, \quad (4.23d)$$

$$f_5 = 2(m/\gamma)\varphi_5 = -m^2(G_2 + G_4), \quad (4.23e)$$

where $z = \cos\theta$, $\gamma = \sin\theta$, and we have introduced the new set of covariant amplitudes

$$\begin{aligned} 4\pi G_1 &= F_1 - 4F_3 + F_5, \\ 4\pi G_2 &= 2F_2, \\ 4\pi G_3 &= F_1 - 2F_3 - F_5, \\ 4\pi G_4 &= 2F_4, \\ 4\pi G_5 &= F_1 + 4F_3 + F_5. \end{aligned} \quad (4.24)$$

A factor E has been included in the definition of the f 's, in order to make them even functions of this variable.

Aside from their simple relation to the covariant amplitudes G_i , the new scattering amplitudes have another advantage over the initial φ 's, in that the partial wave amplitudes f^J may be projected out of them by means of Legendre polynomials (rather than the functions $d_{\lambda\mu}^J$). We find

$$f_0^J = \frac{p}{2E} \int_{-1}^1 f_1(s, z) P_J(z) dz, \quad (4.25a)$$

$$f_{11}^J = \frac{p}{2E} \int_{-1}^1 f_2(s, z) P_J(z) dz, \quad (4.25b)$$

$$f_{12}^J = \frac{p}{2m} \int_{-1}^1 f_3(s, z) [J(J+1)]^{1/2} / (2J+1) \\ \times [P_{J+1}(z) - P_{J-1}(z)] dz, \quad (4.25c)$$

$$f_{22}^J = \frac{1}{2J+1} \frac{p}{2E} \int_{-1}^1 \left[f_3(s, z) P_J(z) \right. \\ \left. + f_4(s, z) \frac{JP_{J+1}(z) + (J+1)P_{J-1}(z)}{2J+1} \right] dz, \quad (4.25d)$$

$$f_1^J = \frac{1}{2J+1} \frac{p}{2E} \int_{-1}^1 \left[f_4(s, z) P_J(z) \right. \\ \left. + f_3(s, z) \frac{JP_{J+1}(z) + (J+1)P_{J-1}(z)}{2J+1} \right] dz. \quad (4.25e)$$

TABLE I. Allowed transitions in nucleon-nucleon scattering: $(-1)^{l+l+1} = -1$.

	$s=0$	$J=l$	$s=1$	$J=l\pm 1$
	$I=0$ $I=1$	J odd J even	J even J odd	J odd J even

The expressions for the transition amplitudes in states of given orbital angular momentum l may readily be obtained by means of Clebsch-Gordon coefficients. They are

$$f_{l=J-1} = [1/(2J+1)] \{ J f_{11}^J + (J+1) f_{22}^J \\ + 2[J(J+1)]^{1/2} f_{12}^J \}, \quad (4.26a)$$

$$f_{l=J+1} = 1/(2J+1) \{ (J+1) f_{11}^J + J f_{22}^J \\ - 2[J(J+1)]^{1/2} f_{12}^J \}, \quad (4.26b)$$

$$f_{J-1, J+1} = [1/(2J+1)] \{ [J(J+1)]^{1/2} \\ \times (f_{22}^J - f_{11}^J) - f_{12}^J \}. \quad (4.26c)$$

From an analysis of the behavior of partial waves at threshold, namely that transition amplitudes in a state of orbital angular momentum l , or of the type $(l-1) \rightleftharpoons (l+1)$ behave like p^{2l} , we may conclude that in the vicinity of $p=0$ the G 's behave either like constants, or like $p^2 z$, according to whether they are even or odd functions of z .

In the following section, where we write down dispersion relations for the partial wave amplitudes, we shall come across nonphysical values of the energy. To deal with this situation we may wish to express the amplitudes in such unphysical regions in terms of amplitudes for process (II). Therefore, our task now is to derive crossing relations for the f 's. To this effect we have to establish first crossing relations for the G 's by connecting them to \bar{G} 's describing the reaction (II), then express the \bar{G} 's in terms of corresponding \bar{f} 's, and finally the f 's in terms of \bar{f} 's. The first step is easily carried out by using the crossing relations (2.19) for the F 's. We obtain

$$G(s, \bar{l}, t) = \Delta B \bar{G}(\bar{l}, s, t), \quad (4.27)$$

where

$$\Delta = - \begin{bmatrix} -1 & 6 & 4 & -4 & -1 \\ 1 & 2 & 0 & 0 & 1 \\ 1 & 0 & 2 & 2 & -1 \\ 4 & -1 & 0 & 2 & 1 \\ -1 & 6 & -4 & 4 & -1 \end{bmatrix}, \quad (4.28)$$

and B is the isotopic crossing matrix (2.20). We write then

$$f_i(s, z) = a_{ij}(s, z) \Delta_{jk} B \bar{G}_k(\bar{l}, s, t), \quad (4.29)$$

or

$$f(s, z) = A(s, z) B \bar{G}(\bar{l}, s, t), \quad (4.30)$$

where $f = \{f^0, f^1\}$ is a vector in isotopic spin space, the indices again referring to $I=0$ or $I=1$; the a_{ij} 's are the

coefficients of the G 's in (4.23) and $A(s, z) = a(s, z)\Delta$ is the matrix

$$A = \begin{pmatrix} 1 & \begin{bmatrix} -\frac{1}{2}p^2(1+z) & 3E^2 - p^2z & 3E^2 - p^2 & -E^2 - p^2 & -m^2 - \frac{1}{2}p^2(1+z) \\ \frac{1}{2}p^2(1+z) & -3p^2 + E^2z & m^2z + 2p^2 & m^2z - 2p^2 & \frac{1}{2}(E^2 + m^2)z + p^2 \\ -\frac{1}{2}p^2 & 0 & -p^2 & -p^2 & \frac{1}{2}p^2 \\ 2 & -\frac{1}{2}p^2 & m^2 & E^2 & \frac{1}{2}(E^2 + m^2) \\ 0 & -m^2 & -m^2 & -m^2 & -m^2 \end{bmatrix} \end{pmatrix}. \quad (4.31)$$

Finally we want the amplitudes $\bar{G}(\bar{i}, s, t)$ expressed in terms of the amplitudes $\bar{f}(\bar{E}, \bar{z})$ in the center-of-mass system for process (II), with the nucleon energy \bar{E} and the scattering angle $\cos^{-1} \bar{z}$ between the nucleons (particles 1), given by

$$\begin{aligned} \bar{i} &= 4\bar{E}^2 = 4(\bar{p}^2 + m^2), \\ t &= -2\bar{p}^2(1 - \bar{z}), \\ s &= -2\bar{p}^2(1 + \bar{z}). \end{aligned} \quad (4.32)$$

Since the connection between the covariant and scattering amplitudes in the center-of-mass system are formally the same for processes (I) and (II), the required

relations are obtained by inverting a system of equations of the type (4.23). The result is

$$\bar{G}_1 = (1/\bar{E}^2)[f_1 + (m^2/\bar{p}^2)\bar{f}_3 - \bar{z}\bar{f}_4 - \bar{z}(\bar{E}^2/m^2)\bar{f}_5], \quad (4.33a)$$

$$\bar{G}_2 = -(1/\bar{p}^2)[\bar{f}_4 + (\bar{E}^2/m^2)\bar{f}_5], \quad (4.33b)$$

$$\bar{G}_3 = -(1/\bar{p}^2)\bar{f}_3, \quad (4.33c)$$

$$\bar{G}_4 = (1/\bar{p}^2)(\bar{f}_4 + \bar{f}_5), \quad (4.33d)$$

$$\bar{G}_5 = -(1/\bar{p}^2)[\bar{f}_2 + \bar{z}\bar{f}_4 + \bar{z}[(\bar{E}^2 + m^2)/m^2]\bar{f}_5]. \quad (4.33e)$$

Substituting into (4.30) we can obtain the desired relations between $f(E, z)$ and $\bar{f}(\bar{E}, \bar{z})$, namely $f(E, z) = X\bar{f}(\bar{E}, \bar{z})$, where

$$X = \frac{1}{2} \begin{vmatrix} 1 & -1 & \frac{-s}{2\bar{p}^2} & \frac{-s}{2\bar{p}^2} & 0 \\ -1 & -1 + \frac{it}{8\bar{p}^2\bar{p}^2} & \frac{t}{2\bar{p}^2} + \frac{s\bar{s}}{8\bar{p}^2\bar{p}^2} & -\left[\frac{t}{2\bar{p}^2} + \frac{st}{8\bar{p}^2\bar{p}^2}\left(1 + \frac{s}{2\bar{p}^2}\right)\right] & \frac{s\bar{t}\bar{t}}{8\bar{p}^2\bar{p}^2} \\ \frac{2\bar{p}^2}{i} & \frac{s - 4m^2}{8\bar{p}^2} & \frac{\bar{p}^2}{\bar{p}^2}\left(1 - \frac{2m^2}{i}\right) & -\frac{\bar{p}^2}{\bar{p}^2}\left[1 - \frac{2m^2}{i}\left(1 + \frac{s}{2\bar{p}^2}\right)\right] & \frac{2s\bar{p}^2 + \bar{t}\bar{t}}{4\bar{p}^4} \\ \frac{2\bar{p}^2}{i} & \frac{s + 4m^2}{8\bar{p}^2} & -\frac{\bar{p}^2}{\bar{p}^2}\left[1 + \frac{2m^2}{i}\left(1 + \frac{i}{2\bar{p}^2}\right)\right] & -\frac{\bar{p}^2}{\bar{p}^2}\left[1 + \frac{2m^2}{i}\left(1 + \frac{s}{2\bar{p}^2}\right)\left(1 + \frac{i}{2\bar{p}^2}\right)\right] & -\frac{2s\bar{p}^2 + \bar{t}\bar{t}}{4\bar{p}^4} \\ 0 & \frac{m^2}{\bar{p}^2} & \frac{m^2}{\bar{p}^2} & -\frac{m^2}{\bar{p}^2}\left(1 + \frac{s}{2\bar{p}^2}\right) & \frac{2\bar{p}^2}{\bar{p}^2}\left(1 - \frac{s\bar{t}}{8\bar{p}^2\bar{p}^2}\right) \end{vmatrix}$$

Before turning to the discussion of the analyticity of the partial wave amplitudes, let us settle the question concerning the behavior of the covariant amplitudes at s , t , or $\bar{i}=0$. In the previous section we have argued that the covariant amplitudes have the analytic behavior implied by the Mandelstam representation except for the possibility of poles at s , \bar{i} , or $t=0$. To study this question we examine Eq. (4.23).

It is clear that at $\bar{i}=0$ ($z=1$) or $\bar{i}=0$ ($z=-1$) the G 's will have singularities unless

$$\begin{aligned} \varphi_3(z=-1) &= 0, \\ \varphi_4(z=+1) &= 0, \\ \varphi_5(z=\pm 1) &= 0. \end{aligned}$$

From the definitions (4.8) it follows that $\varphi_3(-1)$, $\varphi_4(1)$; and $\varphi_5(-1)$ represent transitions in which the z -com-

ponent of the angular momentum is not conserved. Therefore they must vanish. Similarly the fact that there is no singularity at $s=0$ can be deduced by a corresponding argument applied to the $N\bar{N}$ amplitudes.

The behavior of the amplitudes at infinity is, as usual, rather more difficult to specify. For fixed values of $\cos\theta$ it is reasonable to assume on physical grounds that f_1 , f_2 , f_3 , and f_4 approach constants as $s \rightarrow \infty$ while $f_5 \rightarrow 0$. This follows on the real axis from the boundedness of the partial wave amplitudes due to unitarity; the point at infinity is (as is already implicit in the representation) no worse than a branch point or a pole so the same conclusion about the f 's may be drawn for complex s . From the formulas relating the G 's to the f 's (Eq. (4.33) we see that the G 's, for fixed z approach zero at infinity. This implies that there are no over-all constants in the representations of the G 's.

The relevance of these remarks for the partial wave dispersion relations is discussed in Sec. VII.

V. DISPERSION RELATIONS FOR THE PARTIAL WAVE AMPLITUDES

The deduction of partial wave dispersion relations from the Mandelstam representation has been treated by MacDowell,¹⁰ by Frazer and Fulco¹¹ and by Chew and Mandelstam.¹² The corresponding discussion in non-relativistic theory has been given by Blankenbecler, Goldberger, Khuri, and Treiman.¹³ Because of the complexity of the present problem and since one important detail had been overlooked in some of the previous treatments we shall explain the method from the beginning.

We have learned in Sec. IV how to project the helicity amplitudes corresponding to total angular momentum J from the amplitudes f_i , by means of Eqs. (4.25a-e). Further, we know how to relate the f 's to the G 's which have a Mandelstam representation. Instead of discussing the analyticity properties of the f 's, it is useful to remove certain trivial (and nonanalytic) factors which appear in these quantities. We multiply $f_0^J, f_{11}^J, f_{22}^J, f_1^J$ by E/p and call the resulting functions $h_0^J, h_{11}^J, h_{22}^J, h_1^J$, and multiply f_{12}^J by m/p and call the result h_{12}^J . The general structure of the quantities from which the analytic properties of the h 's are to be deduced is

$$h_\alpha^J(s) = \int_{-1}^1 dz \left[\sum_{i,i',j,j'} C_{\alpha i i' j j'} a_{ij}(s, z) G_j(s, \bar{t}, t) \right] P_{J'}(z), \quad (5.1)$$

where \bar{t} and t are to be expressed in terms of s and z according to the definition (4.1). The index α takes on the values 0, 11, 22, 12, 1; i and j run from 1 to 5, and J' in general runs over $J-1, J, J+1$. The matrix $a_{ij}(s, z)$ has been defined just below Eq. (4.30) and the $C_{\alpha i i' j j'}$ are the numerical factors which appear in (4.25). For example

$$C_{12, i i' j j'} = \{ [J(J+1)]^{1/2} / (2J+1) \} \delta_{i,5} \times [\delta_{j', J+1} - \delta_{j', J-1}]. \quad (5.2)$$

Next, we substitute the representation for the G 's (which are linear combinations of the F 's) from Eq. (3.3) and imagine carrying out the integration over z . We then study the location of the zeros of the denominators $s'-s, \bar{t}'-\bar{t}, t'-t$ regarded as functions of s and z , as z goes over its integration range.

Let us dispose first of the Born terms which, as is well known, have the structure $(\mu^2-t)^{-1} = [\mu^2 + 2p^2(1-z)]^{-1}$ and $(\mu^2-\bar{t})^{-1} = [\mu^2 + 2p^2(1+z)]^{-1}$. The first term gives rise to a branch line in the h 's which extends from $p^2 = -\mu^2/4$ to $-\infty$ or, in terms of s , from $s = 4m^2 - \mu^2$ to

$s = -\infty$. The second term gives rise to the same cut. Since the Born terms are explicitly known, we can actually carry out the integration in (5.1), and obtain thereby a contribution to $h_\alpha^J(s)$ which we call $h_{\alpha B}^J(s)$. The deuteron pole, which appears only in the $I=0, J=1$ amplitude, will be left out for the time being. We have some information about it, but since we hope to be able to calculate from first principles at least the residue at this pole, if not its location, we will not include it at this point.

Turning now to the double integrals in the representation for the G 's, we note first that from the vanishing of $s'-s$ there is a cut in the s plane extending from $4m^2$ to infinity along the real axis. Next we consider the vanishing of the denominator $\bar{t}'-\bar{t}$; since \bar{t}' varies from $4\mu^2$ to ∞ , we obtain a cut in the \bar{t} variable extending over this range. In terms of s as a variable, with $s-4m^2 = -2\bar{t}/(1+z)$ we have a cut in the s plane from $s = 4(m^2 - \mu^2)$ to $s = -\infty$. It is clear from symmetry considerations that the vanishing of $t'-t$ gives rise to the same cut. It should be noted however that, since \bar{t}' has the minimum value $4\mu^2$, for a given s (or p^2) the denominator $\bar{t}'-\bar{t}$ vanishes only for z in the interval $-1 - 2\mu^2/p^2 < z < 1$ (note that $p^2 < 0$ whenever $\bar{t}'-\bar{t}=0$). Similarly, $t'-t$ vanishes only for z restricted by $-1 < z < 1 + 2\mu^2/p^2$. This accounts for the limits on the integrals which appear later in (5.6) and (5.7). To summarize, $h_\alpha^J(s) - h_{\alpha B}^J(s)$ is, except for poles associated with the existence of bound states, analytic in the s plane cut from $s = 4m^2$ to ∞ and $-\infty$ to $4(m^2 - \mu^2)$ along the real axis. We might add that the presence of subtractions in the original representation does not affect these conclusions.

We give now a representation for the $h_\alpha^J(s)$ which embodies these characteristics. In order not to complicate the formulas unnecessarily we shall not worry about the question of subtractions or the desirability of insuring the proper behavior of our amplitudes near $s = 4m^2$, by dividing $h_\alpha^J(s)$ by appropriate powers of $p^2 = s/4 - m^2$ (see MacDowell, reference 10); these questions will be dealt with in Sec. VII. We write, on the basis of the remarks in the previous paragraph (assuming, incorrectly, that $h_\alpha^J(s)$ vanishes at infinity),

$$h_\alpha^J(s) = h_{\alpha B}^J(s) + \frac{1}{\pi} \int_{4m^2}^{\infty} ds' \frac{\text{Im} h_\alpha^J(s')}{s' - s} + \frac{1}{\pi} \int_{-\infty}^{4(m^2 - \mu^2)} ds' \frac{\text{Im} [h_\alpha^J(s') - h_{\alpha B}^J(s')]}{s' - s}. \quad (5.3)$$

In both terms we define the imaginary parts by using the instruction $\text{Im} h_\alpha^J(s) = [h_\alpha^J(s+i\epsilon) - h_\alpha^J(s-i\epsilon)]/2i$.

We may compute now the indicated imaginary parts in terms of the weight functions appearing in the representation for the G 's. [These weight functions are linear combinations of the ones appearing in the representation for the F 's and it is clear, from an examina-

¹⁰ S. W. MacDowell, Phys. Rev. **116**, 774 (1959).

¹¹ W. R. Frazer and J. R. Fulco, Phys. Rev. **117**, 1603 (1960).

¹² G. F. Chew and S. Mandelstam, Phys. Rev. **119**, 467 (1960).

¹³ R. Blankenbecler, M. L. Goldberger, Khuri, and Treiman, Ann. Phys. **10**, 62 (1960).

tion of Eq. (4.24), that they have the same symmetry properties. Since we use them for formal manipulations only, we shall keep the same symbol ρ .] We find, for s in the interval $4m^2 < s < \infty$

$$\text{Im}h_{\alpha}^J(s) = \sum_{i,j,J'} C_{\alpha i}^{JJ'} \int_{-1}^1 dz a_{ij}(s,z) \times \left[\int_{4\mu^2}^{\infty} \frac{d\bar{t}'}{\pi} \frac{\rho_{12}^j(s,\bar{t}')}{\bar{t}' - \bar{t}} + \int_{4\mu^2}^{\infty} \frac{dt'}{\pi} \frac{\rho_{13}^j(s,t')}{t' - t} \right] P_{J'}(z). \quad (5.4)$$

Reference to Eq. (3.11) shows that the quantity in brackets is just the absorptive part $A_j(s,t)$ of the one-dimensional dispersion relation for the relevant G_j . Therefore we write

$$\text{Im}h_{\alpha}^J(s) = \sum_{i,j,J'} C_{\alpha i}^{JJ'} \int_{-1}^1 dz \times a_{ij}(s,z) A_j(s,t) P_{J'}(z), \quad 4m^2 < s < \infty. \quad (5.5)$$

In this equation t is to be interpreted as $-2p^2(1-z)$ in carrying out the z integration. Since s is in the physical region, in practice we shall use the unitarity condition for $h_{\alpha}^J(s)$ directly; Eq. (5.5) is simply an explicit statement of this condition.

The value of $\text{Im}h_{\alpha}^J(s)$ in the region $-\infty < s < 4 \times (m^2 - \mu^2)$ is somewhat more difficult to obtain. As we have explained, it arises from the vanishing of $\bar{t}' - \bar{t}$ and $t' - t$ in (3.3). There is therefore a contribution from all three terms in the Mandelstam representation; from the one involving both factors $\bar{t}' - \bar{t}$ and $t' - t$ we obtain two contributions, since each of the factors may vanish. We find, for the interval $-\infty < s < 4(m^2 - \mu^2)$:

$$\begin{aligned} \text{Im}[h_{\alpha}^J(s) - h_{\alpha B}^J(s)] &= - \sum_{i,j,J'} C_{\alpha i}^{JJ'} \int_{(-1-2\mu^2/p^2)}^1 dz a_{ij}(s,z) \\ &\times \left[\int_{4\mu^2}^{\infty} \frac{ds'}{\pi} \frac{\rho_{12}^j(s',\bar{t})}{s' - s} + P \int_{4\mu^2}^{\infty} \frac{dt'}{\pi} \frac{\rho_{23}^j(\bar{t},t')}{t' - t} \right] P_{J'}(z) \\ &- \sum_{i,j,J'} C_{\alpha i}^{JJ'} \int_{-1}^{1+2\mu^2/p^2} dz a_{ij}(s,z) \left[\int_{4\mu^2}^{\infty} \frac{ds'}{\pi} \frac{\rho_{13}^j(s',t)}{s' - s} \right. \\ &\quad \left. + P \int_{4\mu^2}^{\infty} \frac{d\bar{t}'}{\pi} \frac{\rho_{23}^j(\bar{t}',t)}{\bar{t}' - \bar{t}} \right] P_{J'}(z). \quad (5.6) \end{aligned}$$

The minus signs in (5.6) arise from our convention about how the imaginary part is to be defined:

$$\text{Im} \left(\frac{1}{\bar{t}' - \bar{t}} \right) = \text{Im} \left(\frac{1}{\bar{t}' + 2(s/4 - m^2)(1+z) + i\epsilon} \right) = -\pi \delta(\bar{t}' - \bar{t}).$$

The expressions in the square brackets have been identi-

fied in Sec. III and may be taken directly from Eqs. (3.10) and (3.12) except that the crossing matrices for the G 's, introduced in Sec. IV, must be used. Note the appearance of the principal value sign in front of the integrals over ρ_{23} in (5.6); this implies that we must take the real part of the absorptive amplitudes of Sec. III.

We have then, introducing an obvious vector-matrix notation

$$\begin{aligned} \text{Im}[h^J(s) - h_B^J(s)] &= - \sum_{J'} C^{JJ'} \int_{-1-2\mu^2/p^2}^1 dz a(s,z) \Delta B \text{Re} \bar{A}(\bar{t},t) P_{J'}(z) \\ &- \sum_{J'} C^{JJ'} \int_{-1}^{1+2\mu^2/p^2} dz a(s,z) \\ &\quad \times K \Delta B \text{Re} \bar{A}(t,\bar{t}) P_{J'}(z), \quad (5.7) \end{aligned}$$

with the understanding that we must write $t = -2p^2 \times (1-z)$, $\bar{t} = -2p^2(1+z)$ and $p^2 = s/4 - m^2$. If it were not for the rather subtle point of the appearance of the real parts of the absorptive amplitudes,¹⁰ one could have deduced Eq. (5.7) using crossing symmetry, without reference to the Mandelstam representation (as done in references 11 and 12).

A close examination of the matrices appearing in the second term of (5.7) allows us to simplify the equation somewhat. We change the variable of integration from z to $-z$, in which case the limits of the two integrals become the same; further, we note that \bar{t} and t get interchanged. The properties of $C^{JJ'} a(s, -z) K P_{J'}(-z)$ are just such that for all allowed transitions, i.e., those for which $(-1)^{l+l'} = -1$, the second term in (5.7) is identical to the first. This of course is no accident, but a direct consequence of the Pauli principle.

The next step consists in substituting (5.7) into (5.3). Depending upon algebraic convenience, it may be desirable to make a series of variable changes so that, insofar as it is possible, the arguments of the \bar{A} 's appear in the physical range for reaction (II). The procedure is slightly involved, so that we give some details. We temporarily drop all irrelevant subscripts, constant matrices, etc. We are then led to consider the following double integral I , given by

$$\begin{aligned} I &= - \int_{-\infty}^{4(m^2 - \mu^2)} ds' \frac{1}{s' - s} \int_{(-1-2\mu^2/p^2)}^1 dz a(s',z) \\ &\quad \times \bar{A}[-2p'^2(1+z), -2p'^2(1-z)] P_{J'}(z). \quad (5.8) \end{aligned}$$

We introduce a new variable $\bar{t}' = -2p'^2(1+z)$ in place of z , and obtain

$$\begin{aligned} I &= \int_{-\infty}^{4(m^2 - \mu^2)} ds' \frac{1}{s' - s} \int_{4\mu^2}^{-4p'^2} \frac{d\bar{t}'}{2p'^2} a(s',z) \\ &\quad \times \bar{A}[\bar{t}', -2p'^2(1-z)] P_{J'}(z), \quad (5.9) \end{aligned}$$

where $z = -1 - \bar{t}'/2\bar{p}'^2$. Next, interchanging the order of integration and defining $\bar{p}'^2 = \bar{t}'/4 - m^2$, we find

$$I = \int_{4\mu^2}^{\infty} d\bar{t}' \int_{-\infty}^{-4\bar{p}'^2} \frac{ds'}{2\bar{p}'^2 s' - s} a(s', z) \bar{A}[\bar{t}', -2\bar{p}'^2(1-z)] P_{J'}(z). \quad (5.10)$$

Finally, we introduce a new angular variable z , in place of s' ; the object is to turn $-2\bar{p}'^2(1-z)$ into a momentum transfer variable which corresponds to the energy \bar{t}' . Thus, we define \bar{z} by $-2\bar{p}'^2(1-z) = -2\bar{p}'^2(1-\bar{z})$, which means $s' = -2\bar{p}'^2(1+\bar{z})$ as it should. In making the variable change we must split the range of the \bar{t}' integration into $4\mu^2 < \bar{t}' < 4m^2$ where $\bar{p}'^2 < 0$, and $4m^2 < \bar{t}' < \infty$ where $\bar{p}'^2 > 0$. We obtain then

$$I = - \left(\int_{4\mu^2}^{4m^2} \int_{-\infty}^1 d\bar{z} - \int_{4m^2}^{\infty} \int_1^{\infty} d\bar{z} \right) \left[\frac{\bar{p}'^2}{\bar{p}'^2 2\bar{p}'^2(1+\bar{z}) + s} a(s', z) \bar{A}(\bar{t}', -2\bar{p}'^2(1-\bar{z})) \right] \times P_{J'}(z), \quad (5.11)$$

where we must interpret z, \bar{p}'^2, s , as

$$\begin{aligned} s' &= -2\bar{p}'^2(1+\bar{z}), \\ \bar{p}'^2 &= \frac{1}{4}s' - m^2, \\ z &= -1 - \bar{t}'/2\bar{p}'^2 = \left[\frac{1}{2}\bar{t}' + \bar{p}'^2(1-\bar{z}) \right] / [2m^2 + \bar{p}'^2(1+\bar{z})]. \end{aligned} \quad (5.12)$$

A somewhat simpler looking form of this result may be obtained by introducing the momentum transfer variable \bar{t}' in place of the angular variable \bar{z} . We define $\bar{t}' = -2\bar{p}'^2(1-z)$ and eliminate s' . We find then

$$I = 4 \int_{4\mu^2}^{\infty} d\bar{t}' \int_0^{\infty} d\bar{t}' \times \frac{1}{\bar{t}' + \bar{t}'} \frac{1}{\bar{t}' + \bar{t}' - 4m^2 + s} a\left(4m^2 - \bar{t} - \bar{t}', \frac{\bar{t}' - \bar{t}'}{\bar{t}' + \bar{t}'}\right) \times \bar{A}(\bar{t}', \bar{t}') P_{J'}\left(\frac{\bar{t}' - \bar{t}'}{\bar{t}' + \bar{t}'}\right), \quad (5.13)$$

where we have written the z dependence explicitly.

As we mentioned earlier, it is largely a matter of convenience whether or not the complicated manipulation above should be used in practice. One possible virtue of the procedure is the fact that we can now readily expand \bar{A} in terms of Legendre polynomials (with \bar{t}' as the energy and z as the cosine of the scattering angle), in the region where such an expansion is convergent. The determination of this region can be easily effected by inspection of (5.11) rather than (5.8).

It is worth noting that the boundary of the region where the Legendre expansion converges is precisely the place where we must distinguish between \bar{A} and

$\text{Re}\bar{A}$. The whole problem is slightly academic since, unless we want to resort to perturbation theory in order to compute \bar{A} , we have no choice but to use the partial wave expansion, whether or not it converges. In practice, we shall take only a few terms of the expansion, and disbelieve anything that happens for large arguments. However, the calculation of the precise boundary is worth performing, since at a future time we may be able to overcome the present difficulty.

For this purpose, we turn to the expansion of the absorptive part in terms of a sum over states, as given in (3.15). It is obvious that, barring extreme anomalies, the domain of analyticity in z will be determined by the least massive intermediate state, namely that of two pions (we recall that we have split off the one pion contribution to the absorptive part). Fortunately, it is not necessary to know in detail the nucleon-antinucleon annihilation amplitude into two pions, in order to determine the boundary of the region. It is sufficient to use the Born approximation to this amplitude; this is a well known characteristic of the iterative construction of the weight functions \bar{p} in (3.4), as has been described by Mandelstam.² In fact, the answer to our problem could be read from results obtained by him, by suitably changing variables; however, since the calculation is short, we give it here.

Spin and isotopic spin play no role in this essentially geometric argument and for the sake of clarity we drop them temporarily. In the evaluation of (3.15) we write for the matrix element $\langle Q_1 Q_2 | \bar{f} | \bar{P}_2 \rangle$ which enters there,

$$\langle q_1 q_2 | \bar{f} | \bar{P}_2 \rangle \sim [(P_1 - q_1)^2 + m^2]^{-1} \pm [(P_1 - q_2)^2 + m^2]^{-1}, \quad (5.14)$$

where the sign depends on details of Dirac and isotopic spin algebra, and $P_1 = q_1 + q_2 - P_2$. Similarly,

$$\langle \bar{P}_2' | f | q_1 q_2 \rangle \sim [(P_1' - q_1)^2 + m^2]^{-1} \pm [(P_1' - q_2)^2 + m^2]^{-1}, \quad (5.15)$$

where $P_1' = q_1 + q_2 - P_2'$. Substituting into (3.15) and carrying out the integrations in the rest frame of $P_1 + P_2$ we obtain, up to irrelevant factors,

$$\bar{A}(s, \bar{t}, t) = \int d\Omega(\hat{q}) \times \left[\frac{1}{\lambda - \hat{p}' \cdot \hat{q}} \frac{1}{\lambda - \hat{q} \cdot \hat{p}} \pm \frac{1}{\lambda - \hat{p}' \cdot \hat{q}} \frac{1}{\lambda + \hat{q} \cdot \hat{p}} \right], \quad (5.16)$$

where $\lambda = (s/2 - \mu^2)/pq$, $\bar{p}^2 = s/4 - m^2$, $q^2 = s/4 - \mu^2$, and the vectors in (5.16) are unit vectors. We are reverting to our original labeling of the scalars s, \bar{t}, t of (2.2). The integral is readily transformed into the following:

$$\bar{A} = \int_{\eta_0}^{\infty} d\eta \frac{1}{\eta - \cos\theta} \frac{1}{\chi(\eta)} \pm \int_{\eta_0}^{\infty} d\eta \frac{1}{\eta + \cos\theta} \frac{1}{\chi(\eta)}, \quad (5.17)$$

$$\begin{aligned} \chi(\eta) &= (1/4\pi)[(\eta - \lambda^2)^2 - (\lambda^2 - 1)], \\ \eta_0 &= 2\lambda^2 - 1, \quad \cos\theta = \hat{p}' \cdot \hat{p}. \end{aligned}$$

for $J-1 \rightarrow J+1$ and $J+1 \rightarrow J-1$ are equal.) Thus, five amplitudes are needed, as stated above.

Precisely the same type of counting may be carried out for the nucleon-antinucleon system. Here, of course, the Pauli principle cannot be used, but invariance under the "G" operation of Lee and Yang⁵ insures that there are no singlet-triplet transitions. [This operation, together with parity conservation, implies that the sum $S+I$, where S is the total spin (0 or 1) is conserved; having assumed conservation of I , it follows that S is conserved.] Since we shall establish later analytic crossing relations between the nucleon-nucleon and nucleon-antinucleon amplitudes, it would have been distressing to have the number of these amplitudes different for the two processes.

The next step in our procedure is the selection of an appropriate set of five covariant amplitudes in terms of which the scattering matrix may be expressed. There are no very well defined rules for making a specific choice, but the following points should be considered: we would like our amplitudes to exhibit in a simple fashion the properties implied by the Pauli principle (corresponding to the interchange $t \rightleftharpoons \bar{t}$); and by crossing symmetry (the interchange $s \rightleftharpoons \bar{t}$); further, we wish to avoid kinematical factors which may introduce additional, nonphysical singularities into the amplitudes. However, there does not seem to exist any choice of amplitudes which transform simply under both the Pauli principle and crossing symmetry operations. Since the Pauli principle plays an important role in our discussion, we have chosen our amplitudes accordingly. In this respect, and in the fact that our amplitudes are devoid of kinematical singularities, our choice seems superior to the G.N.O. set.

We shall write the Feynman amplitude \mathfrak{T}_I for process (I) in the form

$$\begin{aligned} \mathfrak{T}_I = & [F_1^0(S-\bar{S}) + F_2^0(T+\bar{T}) \\ & + F_3^0(A-\bar{A}) + F_4^0(V+\bar{V}) + F_5^0(P-\bar{P})] \mathfrak{P}_0 \\ & + [F_1^1(S-\bar{S}) + F_2^1(T+\bar{T}) + F_3^1(A-\bar{A}) \\ & + F_4^1(V+\bar{V}) + F_5^1(P-\bar{P})] \mathfrak{P}_1, \end{aligned} \quad (2.3)$$

where the F 's are functions of the scalars s , \bar{t} , and t defined in (2.2). Our notation is such that in $F(x,y,z)$ the first variable always denotes the square of the total energy, the second and third the negative of the square of the momentum transfers between pairs (1,2) and (1,1), respectively. \mathfrak{P}_0 and \mathfrak{P}_1 are the projection operators for isotopic singlet and triplet states. Specifically,

$$\begin{aligned} \mathfrak{P}_0 &= (1 - \tau_1 \cdot \tau_2)/4, \\ \mathfrak{P}_1 &= (3 + \tau_1 \cdot \tau_2)/4, \end{aligned} \quad (2.4)$$

where τ_1, τ_2 are the usual isotopic spin operators for particles 1 and 2. We are treating \mathfrak{T}_I as a matrix in I -spin space. Our representation is analogous to the one

used in β decay. We have written

$$\begin{aligned} S &= \bar{u}(P_2') u(P_2) \bar{u}(P_1') u(P_1), \\ T &= \frac{1}{2} \bar{u}(P_2') \sigma_{\mu\nu} u(P_2) \bar{u}(P_1') \sigma_{\mu\nu} u(P_1), \\ A &= \bar{u}(P_2') i\gamma_5 \gamma_\mu u(P_2) \bar{u}(P_1') i\gamma_5 \gamma_\mu u(P_1), \\ V &= \bar{u}(P_2') \gamma_\mu u(P_2) \bar{u}(P_1') \gamma_\mu u(P_1), \\ P &= \bar{u}(P_2') \gamma_5 u(P_2) \bar{u}(P_1') \gamma_5 u(P_1), \end{aligned} \quad (2.5)$$

\bar{S}, \bar{T} , etc., are obtained by interchanging $\bar{u}(P_2')$ and $\bar{u}(P_1')$. The u 's are positive energy spinors, normalized according to $\bar{u}u = 1$; explicit formulas for them are given in Sec. IV. For convenience we record the well-known matrix for expressing quantities like \bar{S}, \bar{T} , etc., in terms of the "normal" order of the spinors as defined in S, T , etc., above:

$$\begin{pmatrix} \bar{S} \\ \bar{V} \\ \bar{T} \\ \bar{A} \\ \bar{P} \end{pmatrix} = \begin{pmatrix} 1 & 1 & 1 & 1 & 1 \\ 1 & 4 & -2 & 0 & 2 & -4 \\ 6 & 0 & -2 & 0 & 6 \\ 4 & 4 & 2 & 0 & -2 & -4 \\ 1 & -1 & 1 & -1 & 1 \end{pmatrix} \begin{pmatrix} S \\ V \\ T \\ A \\ P \end{pmatrix}. \quad (2.6)$$

The restrictions imposed on the F 's by the Pauli principle are now very easy to obtain. Under the interchange of the final particles' coordinates (momenta, spins, and isotopic spins) $\bar{t} \rightleftharpoons t$ and the full amplitude must change sign. Now \mathfrak{P}_0 changes sign (as may be seen by using the isotopic spin exchange operator $(1 + \tau_1 \cdot \tau_2)/2$) while \mathfrak{P}_1 does not; also under this interchange $S \rightleftharpoons \bar{S}$, etc. Thus, for the isotopic spin singlet, we find that formally interchanging the final particles leads to the same expression but with the signs of F_2 and F_4 reversed. In order to satisfy the Pauli principle (i.e., all signs reversed) we must demand

$$F_i^0(s, \bar{t}, t) = (-1)^i F_i^0(s, t, \bar{t}), \quad (2.7)$$

and by a similar type of argument,

$$F_i^1(s, \bar{t}, t) = (-1)^{i+1} F_i^1(s, t, \bar{t}). \quad (2.8)$$

The general statement of the Pauli principle is then

$$F_i^I(s, \bar{t}, t) = (-1)^{i+I} F_i^I(s, t, \bar{t}). \quad (2.9)$$

We note that in the center-of-mass system, the interchange $\bar{t} \rightleftharpoons t$ corresponds simply to a change of scattering angle from θ to $\pi - \theta$, or $\cos\theta$ to $-\cos\theta$ [see Eq. (4.1)]

We shall write the amplitudes for processes (II) and (III) in exactly the same form as that used for process (I); \mathfrak{T}_{II} and \mathfrak{T}_{III} will have a representation analogous to that of \mathfrak{T}_I in (2.3) with positive energy spinors for the antinucleons, and of course different functions $\bar{F}(s, \bar{t}, t)$ and $\bar{F}'(s, \bar{t}, t)$, respectively.

As is well known, there exist relations between the amplitudes for processes (I) and (II) and (I) and (III), the so-called crossing relations. The crossing symmetry principle is an important feature of present-day quantum field theory, and is expected to hold in any future theory as well. We should point out that the crossing theorem is essentially an empty statement until certain

⁵ T. D. Lee and C. N. Yang, *Nuovo cimento* 3, 749 (1956).

analyticity properties have been established, properties which allow the extension of the amplitudes outside their original domains of definition. Specifically the amplitudes, defined for certain time-like vectors, must be extended into a region where these vectors are space-like.

The consequences of crossing symmetry for the two-nucleon system have been discussed in G.N.O. We shall repeat the relevant part of their argument in terms of our notation. It should be noted that in G.N.O., the crossing relations were derived for the causal amplitude (defined in terms of retarded commutators) which is the natural quantity in dispersion theory. We find it more convenient to use the Feynman amplitude (defined in terms of time-ordered operators); we shall indicate later the relation between the two.

We write

$$\mathfrak{T}_I = \bar{u}_\alpha(P_1') T_{\alpha\beta}^I(P_1', P_1) u_\beta(P_1), \quad (2.10)$$

and by standard formulas [G.N.O., Eq. (2.10)] obtain

$$(2\pi)^4 \delta(P_1' + P_2' - P_1 - P_2) T_{\alpha\beta}^I(P_1', P_1) \\ = i \left(\frac{P_{20} P_{20}'}{m^2} \right)^{\frac{1}{2}} \int d^4x d^4y e^{-iP_1' \cdot x} \vec{D}_{\alpha\alpha'}(x) \\ \times \langle P_2' | T(\psi_{\alpha'}(x), \bar{\psi}_{\beta'}(y)) | P_2 \rangle \vec{D}_{\beta\beta'}(y) e^{iP_1 \cdot y}, \quad (2.11)$$

where

$$\vec{D}_{\alpha\alpha'}(x) = \left[\gamma_\mu \frac{\vec{\partial}}{\partial x_\mu} + m \right]_{\alpha\alpha'}, \\ \vec{D}_{\beta\beta'}(y) = \left[-\gamma_\mu^T \frac{\vec{\partial}}{\partial y_\mu} + m \right]_{\beta\beta'}, \quad (2.12)$$

the arrows indicating that differentiations act only to the right (\rightarrow) or left (\leftarrow). [This formula differs in trivial respects from that of G.N.O.; we are using box normalization, and have not separated out the δ function of overall momentum conservation in (2.12).] In order not to confuse the writing with too many indices we shall use α, β to indicate not only the spinor indices but also the isotopic spin labels of the nucleons.

We write a similar formula for reaction (II), namely

$$\mathfrak{T}_{II} = \bar{u}_\alpha(P_1') T_{\alpha\beta}^{II}(P_1', P_1) u_\beta(P_1), \quad (2.13)$$

$$(2\pi)^4 \delta(P_1' + P_2' - P_1 - P_2) T_{\alpha\beta}^{II}(P_1', P_1) \\ = i \left(\frac{P_{20}' P_{20}}{m^2} \right)^{\frac{1}{2}} \int d^4x d^4y e^{-iP_1' \cdot x} \vec{D}_{\alpha\alpha'}(x) \\ \times \langle \bar{P}_2' | T(\psi_{\alpha'}(x), \bar{\psi}_{\beta'}(y)) | \bar{P}_2 \rangle \vec{D}_{\beta\beta'}(y) e^{iP_1 \cdot y}. \quad (2.14)$$

In this expression $|\bar{P}_2\rangle$ denotes a state of one anti-nucleon with momentum P_2 . We have adopted a definite phase convention: we agree that we always contract first on particle 1, in both initial and final states.

The relation between $|\bar{P}_2\rangle$ and $|P_2\rangle$ is $|\bar{P}_2\rangle = \mathfrak{C} |P_2\rangle$

where \mathfrak{C} is the unitary operator which effects the charge conjugation of state vectors. It induces the following transformation on the field operators:

$$\psi(x) \rightarrow \psi'(x) = \mathfrak{C}^{-1} \psi(x) \mathfrak{C} = i C \tau_2 \bar{\psi}(x), \\ \bar{\psi}(x) \rightarrow \bar{\psi}'(x) = \mathfrak{C}^{-1} \bar{\psi}(x) \mathfrak{C} = i C^{-1} \tau_2 \psi(x), \quad (2.15)$$

where C is the usual unitary matrix which has the properties

$$C^T = -C, \quad C \gamma_\mu^T C^{-1} = -\gamma_\mu; \quad (2.16)$$

in our representation ($\gamma_4 = \beta$, diagonal), $C = i \gamma_2 \gamma_4 = \alpha_2$. Also in our representation (τ_3 diagonal and equal to $+1$ for proton and antineutron),

$$\tau_2 = \begin{pmatrix} 0 & -i \\ i & 0 \end{pmatrix}. \quad (2.17)$$

The important property for our purpose is $\tau_2 \sigma^T \tau_2 = -\sigma$. (Our operation of charge conjugation is the same as the Lee-Yang G operation.⁵)

Expressing the states $|\bar{P}_2'\rangle$ and $|\bar{P}_2\rangle$ in terms of particle states $|P_2'\rangle$ and $|P_2\rangle$ according to the rules discussed above, and using Eqs. (2.15)–(2.17), we find

$$T^{II}(P_1', P_1) = C \tau_2 [T^I(-P_1, -P_1')]^T \tau_2 C^{-1}, \quad (2.18)$$

the transposition being in both Dirac spinor and isotopic spin indices. Under the indicated transformation of momenta we observe that $s = -(P_1 + P_2)^2 \rightarrow -(-P_1' + P_2')^2 = -(P_1 - P_2')^2$; $t = -(P_1 - P_2)^2 \rightarrow -(P_1' - P_2)^2$ and $i = -(P_1 - P_1')^2 \rightarrow -(P_1' - P_1)^2$. With the assumption, to be verified later, that the amplitudes have no branch points at $s=0$, $i=0$, there is no ambiguity in stating that the crossing operation causes the arguments of the invariant functions to undergo the transformation $s \rightleftharpoons i$, $t \rightarrow t$ (one would run into difficulty if, for instance, factors like \sqrt{s} or \sqrt{i} were present).

In order to use Eq. (2.18), we must cast our representation (2.3) into the form (2.10), by disentangling \vec{S} , \vec{T} , etc., according to (2.6), and identifying T^I . We transform the representation for process (II) in a similar manner and, regarding the F 's as vectors in isotopic spin space $\{F_j^0, F_j^1\}$ we obtain the crossing relations between the F 's and the \bar{F} 's:

$$F_j(s, i, t) = \Gamma_{jk} B \bar{F}_k(i, s, t). \quad (2.19)$$

The isotopic crossing matrix B turns out to be

$$B = \frac{1}{2} \begin{pmatrix} -1 & 3 \\ 1 & 1 \end{pmatrix}, \quad (2.20)$$

with the first row and column referring to $I=0$, the second to $I=1$, while Γ_{jk} is the matrix

$$\Gamma = \frac{1}{4} \begin{pmatrix} -1 & 6 & -4 & 4 & -1 \\ 1 & 2 & 0 & 0 & 1 \\ -1 & 0 & 2 & 2 & 1 \\ 1 & 0 & 2 & 2 & -1 \\ -1 & 6 & 4 & -4 & -1 \end{pmatrix}. \quad (2.21)$$

We remark that Γ is the negative of the transposed Fierz

matrix (2.6), written for the order $(S, -T, A, -V, P)$. No deep significance should be attached to this fact; however, it is simply a consequence of our choice of amplitudes. Also $\Gamma^2=1, B^2=1$, as should be, since the relations between the F 's and the \bar{F} 's must be completely symmetric.

The crossing relations connecting reactions (I) and (III) may be deduced by a method completely analogous to the one just used. Alternatively, they can be inferred from our knowledge of the behavior of the F 's under the interchange of \bar{t} and t .

III. ANALYTICITY PROPERTIES OF THE INVARIANT FUNCTIONS

According to Mandelstam's postulate, each of the 256 elements of the matrix [regarding the appropriately disentangled form of (2.3) as a matrix to be sandwiched between initial and final spinors] is an analytic function of the momenta except in the region where s, \bar{t} , and t equal the thresholds for energy conserving intermediate states. However, it is not immediately clear that the invariant functions F_j are analytic in the same domain. To investigate the possibility of additional singularities we first construct five new amplitudes which in fact have no singularities other than the ones present in \mathfrak{Z} , and obtain an explicit relation between them and the F 's. Let us calculate the five scalar invariants

$$T_i = \text{tr}\{0_i \Lambda(P_2) \Lambda(P_1) \mathfrak{Z} \Lambda(P_1) \Lambda(P_2)\}, \quad (3.1)$$

where the 0_i may be taken as the standard β -decay matrices $1^{(1)}1^{(2)}, \gamma_\mu^{(1)}\gamma_\mu^{(2)}$, etc., the Λ 's are positive-energy projection operators $\Lambda(P) = (-i\gamma \cdot P + m)/2m$, and the traces are taken in the spaces of particles 1 and 2. According to the Hall-Wightman theorem,⁶ the T_i 's being invariant functions of the momenta, are analytic in the same domain as the elements of the \mathfrak{Z} matrix.

After carrying out the trace calculations, the final result emerges in the form

$$T_i = D_{ij} F_j, \quad (3.2)$$

where D is a 5×5 matrix whose elements are simple polynomials in s, \bar{t} , and t . The determinant of D is proportional to $(s\bar{t}t)^3$, so that the only possible additional singularities of the F 's are poles at $s=0, \bar{t}=0$ or $t=0$. In fact, as we shall show directly, the F 's are finite at $\bar{t}=0$ or $t=0$, which values correspond to backward or forward nucleon-nucleon scattering. Similarly, using the fact that the nucleon-antinucleon amplitude is finite in the backward direction, the crossing relations allow us to infer that the F 's are regular at $s=0$ as well. We conclude then that we can write for the F 's a Mandelstam representation, which has singularities associated with the thresholds for physical processes only.

We write then the following representation for the

⁶ D. Hall and A. S. Wightman, Kgl Danske Videnskab. Selskab Mat.-fys. Medd. 31, No. 5 (1957).

invariant functions:

$$F_j(s, \bar{t}, t) = \int_{4m^2}^\infty \frac{ds'}{\pi} \int_{4\mu^2}^\infty \frac{d\bar{t}'}{\pi} \frac{\rho_{12}^j(s', \bar{t}')}{(s'-s)(\bar{t}'-\bar{t})} + \int_{4m^2}^\infty \frac{ds'}{\pi} \int_{4\mu^2}^\infty \frac{d\bar{t}'}{\pi} \frac{\rho_{13}^j(s', \bar{t}')}{(s'-s)(\bar{t}'-t)} + \int_{4\mu^2}^\infty \frac{d\bar{t}'}{\pi} \int_{4\mu^2}^\infty \frac{d\bar{t}'}{\pi} \frac{\rho_{23}^j(\bar{t}', \bar{t}')}{(\bar{t}'-\bar{t})(\bar{t}'-t)} + B_j(s, \bar{t}, t). \quad (3.3)$$

We are regarding the F 's, and thus the ρ 's as vectors in isotopic spin space, as mentioned above Eq. (2.19), with components $F_j^I, (I=0, 1)$. μ is the meson mass, and the term $B_j(s, \bar{t}, t)$ denotes the so-called one-meson exchange terms, the Born approximation, which we split off explicitly. The limits on the above integrals are actually the asymptotes of the regions in which the ρ 's are different from zero; we shall deduce later the actual boundaries (see also Mandelstam, reference 2). The contribution of the bound deuteron state (for the $I=0$ amplitude) should also appear explicitly in the complete representation; for reasons to be given later we shall not include it at this point. For the time being we overlook the question of subtractions, which plays no role in the discussion that follows.

The amplitudes for reaction (II) have a similar representation, namely

$$\bar{F}_j(s, \bar{t}, t) = \int_{4\mu^2}^\infty \frac{ds'}{\pi} \int_{4m^2}^\infty \frac{d\bar{t}'}{\pi} \frac{\bar{\rho}_{12}^j(s', \bar{t}')}{(s'-s)(\bar{t}'-\bar{t})} + \int_{4\mu^2}^\infty \frac{ds'}{\pi} \int_{4\mu^2}^\infty \frac{d\bar{t}'}{\pi} \frac{\bar{\rho}_{13}^j(s', \bar{t}')}{(s'-s)(\bar{t}'-t)} + \int_{4m^2}^\infty \frac{d\bar{t}'}{\pi} \int_{4\mu^2}^\infty \frac{d\bar{t}'}{\pi} \frac{\bar{\rho}_{23}^j(\bar{t}', \bar{t}')}{(\bar{t}'-\bar{t})(\bar{t}'-t)} + \bar{B}_j(s, \bar{t}, t). \quad (3.4)$$

The lower limits of integration are again formal; they follow from simple physical considerations of the least massive intermediate states that can be reached by a nucleon-antinucleon pair (aside from the one meson term that we have exhibited separately).

Before proceeding further, let us explain the connection between the Feynman and causal amplitudes. In the spirit of the Mandelstam representation, we must think of one function of three variables which describes all three processes that we are discussing. Such a func-

tion will have a representation of the form

$$\begin{aligned}
 F(x_1, x_2, x_3) &= \int \frac{dx_1'}{\pi} \int \frac{dx_2'}{\pi} \frac{\rho_{12}(x_1', x_2')}{(x_1' - x_1)(x_2' - x_2)} \\
 &+ \int \frac{dx_1'}{\pi} \int \frac{dx_3'}{\pi} \frac{\rho_{13}(x_1', x_3')}{(x_1' - x_1)(x_3' - x_3)} \\
 &+ \int \frac{dx_2'}{\pi} \int \frac{dx_3'}{\pi} \frac{\rho_{23}(x_2', x_3')}{(x_2' - x_2)(x_3' - x_3)}.
 \end{aligned}$$

Let us temporarily abandon our convention whereby we always let the first variable denote the square of the energy. Then, one can make the statement that the function $F(x_1, x_2, x_3)$, where one of the variables is positive (and larger than some minimum value), and the other two are negative or zero, describes that process for which the positive variable denotes the square of the energy. By letting x_1 , x_2 , and x_3 in turn be positive, we obtain the amplitudes for the three possible reactions.

We must have now a prescription for dealing with vanishing denominators. The instruction is $x_\alpha \rightarrow x_\alpha + i\epsilon_\alpha$, where the ϵ 's are positive quantities. With this convention, F gives the Feynman amplitude for any one of the processes, as defined in terms of time-ordered operators. One obtains the causal amplitudes by using the instruction $x_\alpha \rightarrow x_\alpha + i\epsilon_\alpha x_\alpha / |x_\alpha|$. Thus, whereas the same branch of an analytic function F gives the Feynman amplitude for all three processes, the causal amplitudes are obtained by going to different branches of F . The correctness of this instruction may be verified by going over to the one-dimensional dispersion relations, as we shall do presently. It is also easy to verify, by observing that the weight functions are real, that crossing symmetry implies for the causal covariant amplitudes the same kind of relations as (2.19), but with the right-hand side complex conjugated (provided that the variable which is unaffected by the crossing operation is in its physical region).

The number of weight functions which appear in the representation (3.3) can be reduced. *A priori* 30 such functions appear (five F 's \times 2I-spin states \times 3 ρ 's for each F). It turns out that only 20 independent functions exist, and of these ten are symmetric (or anti-symmetric) functions of their arguments. This reduction comes about by virtue of the Pauli principle, which leads to relations of the form

$$\begin{aligned}
 \rho_{13}^j(s', t') &= (-1)^{j+1} \rho_{12}^j(s', t'); \\
 \rho_{23}^j(t', t') &= (-1)^{j+1} \rho_{23}^j(t', t').
 \end{aligned} \quad (3.5)$$

G invariance implies similar relations for the $\bar{\rho}$'s.

From the crossing relations (2.19) and the representations (3.3) and (3.4), we can also deduce a number of relations between ρ 's and the $\bar{\rho}$'s which must hold because, as mentioned above, there exists essentially

only one basic quantity describing all three of our reactions. In order to simplify the notation, let us call the combined crossing matrix operation $\Gamma \times B = \Omega$, and let the indices j, k imply also the isotopic spin label 0 or 1. We find then

$$\begin{aligned}
 \rho_{12}^j(s, t) &= \Omega_{jk} \bar{\rho}_{12}^k(\bar{t}, s), \\
 \rho_{13}^j(s, t) &= \Omega_{jk} \bar{\rho}_{23}^k(s, t), \\
 \rho_{23}^j(\bar{t}, t) &= \Omega_{jk} \bar{\rho}_{13}^k(\bar{t}, t).
 \end{aligned} \quad (3.6)$$

Next, we record the one-dimensional dispersion relations for the F 's and the \bar{F} 's, and exhibit the relations between the weight functions and the absorptive parts of reactions (I) and (II); these formulas will be of use in Sec. V. We have

$$\begin{aligned}
 F_j(s, \bar{t}, t) &= \int_{4m^2}^{\infty} \frac{ds'}{\pi} \frac{A_j(s', t)}{s' - s} \\
 &+ \int_{4\mu^2}^{\infty} \frac{d\bar{t}'}{\pi} \frac{\Omega_{jk} \bar{A}_k(\bar{t}', t)}{\bar{t}' - \bar{t}} + B_j(s, \bar{t}, t),
 \end{aligned} \quad (3.7)$$

$$\begin{aligned}
 \bar{F}_j(s, \bar{t}, t) &= \int_{4\mu^2}^{\infty} \frac{ds'}{\pi} \frac{\bar{A}_j(s', t)}{s' - s} \\
 &+ \int_{4m^2}^{\infty} \frac{d\bar{t}'}{\pi} \frac{\Omega_{jk} A_k(\bar{t}', t)}{\bar{t}' - \bar{t}} + \bar{B}_j(s, \bar{t}, t).
 \end{aligned} \quad (3.8)$$

The relation between the A 's and the weight functions appearing in (3.3) and (3.4) is the following:

$$\bar{A}_j(\bar{t}, t) = \int_{4\mu^2}^{\infty} \frac{d\bar{t}'}{\pi} \frac{\bar{\rho}_{13}^j(\bar{t}', t')}{\bar{t}' - \bar{t}} + \int_{4m^2}^{\infty} \frac{ds'}{\pi} \frac{\bar{\rho}_{12}^j(\bar{t}, s')}{s' - s}, \quad (3.9)$$

or, using (3.6) and the fact that $\Omega^2 = 1$

$$\bar{A}_j(\bar{t}, t) = \Omega_{jk} \left[\int_{4\mu^2}^{\infty} \frac{d\bar{t}'}{\pi} \frac{\rho_{23}^k(\bar{t}', t')}{\bar{t}' - \bar{t}} + \int_{4m^2}^{\infty} \frac{ds'}{\pi} \frac{\rho_{12}^k(s', \bar{t})}{s' - s} \right], \quad (3.10)$$

where, of course, $s = 4m^2 - \bar{t} - t$. Also,

$$A_j(s, t) = \int_{4\mu^2}^{\infty} \frac{d\bar{t}'}{\pi} \frac{\rho_{13}^j(s, \bar{t}')}{\bar{t}' - t} + \int_{4m^2}^{\infty} \frac{ds'}{\pi} \frac{\rho_{12}^j(s, \bar{t}')}{\bar{t}' - \bar{t}}. \quad (3.11)$$

The remaining combination of weight functions, ρ_{23} and Ω_{13} , appears in the following formula:

$$\begin{aligned}
 \bar{A}_j(t, \bar{t}) &= (-1)^{j+1} \Omega_{jk} \left[\int_{4\mu^2}^{\infty} \frac{d\bar{t}'}{\pi} \frac{\rho_{23}^k(\bar{t}', t)}{\bar{t}' - \bar{t}} \right. \\
 &\left. + \int_{4m^2}^{\infty} \frac{ds'}{\pi} \frac{\rho_{13}^k(s', t)}{s' - s} \right].
 \end{aligned} \quad (3.12)$$

The derivation of formulas like (3.9) to (3.12) has been sketched several times in Mandelstam's papers.² For the sake of completeness, and because of the rather involved crossing relations, we shall give some of the details.

Let us rewrite the expression \bar{F}_j given in (3.4), by making a

with $z = -1 - s''/2p'^2$. Interchanging the order of integration we are led to

$$I_2 = \int_{4m^2}^{\infty} ds'' \int_{-\infty}^{-4p'^2} \frac{ds'}{2p'^2 s' - s} a(s', z) \times A[s'', -2p'^2(1-z)] P_{J'}(z). \quad (\text{A.11})$$

Finally, we introduce a new angular variable z'' in place of s' ; the object is to turn $-2p'^2(1-z)$ into a momentum transfer which corresponds to the energy s'' . Thus, we define z'' through $-2p'^2(1-z) = -2p'^2 \times (1-z'')$ which means $s' = -2p'^2(1+z'')$. Since in this case $p'^2 > 0$ over the whole range of s'' , there is no need to split the s'' range of integration as we had to do previously. We obtain finally

$$I_2 = \int_{4m^2}^{\infty} ds'' \int_1^{\infty} dz'' \frac{p'^2}{p'^2} a(s', z) \frac{1}{2p'^2(1+z'') + s} \times A[s'', -2p'^2(1-z'')] P_{J'}(z), \quad (\text{A.12})$$

where

$$\begin{aligned} s' &= -2p'^2(1+z''), \\ p'^2 &= s'/4 - m^2, \\ z &= -1 - s''/2p'^2. \end{aligned} \quad (\text{A.13})$$

An alternative form of the result is obtained by using the momentum transfer variable $t'' = -2p'^2(1-z'')$ in place of z'' . Then

$$I_2 = 4 \int_{4m^2}^{\infty} ds'' \int_0^{\infty} dt'' \frac{1}{s'' + t''} \frac{1}{s'' + t'' - 4m^2 + s} \times a \left[4m^2 - s'' - t'', \frac{s'' - t''}{s'' + t''} \right] \times A(s'', t'') P_{J'} \left(\frac{s'' - t''}{s'' + t''} \right). \quad (\text{A.16})$$

Note that the momentum transfer $t'' > 0$, so that unlimited applicability of the polynomial expansion cannot be expected.

For $\text{Im} \bar{h}_{\alpha\beta}^J$ we carry out a similar calculation. We start with

$$I_3 = - \int_{-\infty}^{4m^2(1-\mu^2/m^2)} \frac{ds'}{s' - s} \int_{-1}^{1+2\mu^2/p'^2} dz a(s', z) \times \bar{A}[-2p'^2(1-z), s'] P_{J'}(z). \quad (\text{A.15})$$

We introduce then in place of z , $\bar{t}'' = -2p'^2(1-z)$ and

find

$$I_3 = \int_{-\infty}^{4m^2(1-\mu^2/m^2)} \frac{ds'}{s' - s} \int_{4\mu^2}^{-4p'^2} \frac{d\bar{t}''}{2p'^2} a(s', z) \times \bar{A}(\bar{t}'', s') P_{J'}(z), \quad (\text{A.16})$$

where $z = 1 + \bar{t}''/2p'^2$. Interchanging the order of integration leads to

$$I_3 = \int_{4\mu^2}^{\infty} d\bar{t}'' \int_{-\infty}^{-4\bar{p}''^2} \frac{ds'}{2p'^2 s' - s} a(s', z) \bar{A}(\bar{t}'', s') P_{J'}(z), \quad (\text{A.17})$$

where $\bar{p}''^2 = \bar{t}''/4 - m^2$. There is no obstacle in interpreting s' as simply the momentum transfer variable in this amplitude. Alternatively, we may write $s' = -2\bar{p}''^2 \times (1 - \bar{z}'')$ and obtain

$$I_3 = \left[\int_{4\mu^2}^{\infty} d\bar{t}'' \int_1^{\infty} d\bar{z}'' - \int_{4m^2}^{\infty} d\bar{t}'' \int_{-\infty}^{-1} d\bar{z}'' \right] \times \frac{\bar{p}''^2}{p'^2 2\bar{p}''^2(1 - \bar{z}'') + s} a(s', z) \times \bar{A}[\bar{t}'', -2\bar{p}''^2(1 - \bar{z}'')] P_{J'}(z), \quad (\text{A.18})$$

where, of course, s' , p'^2 and z must be expressed in terms of the new variables.

Let us find now the region where the Legendre polynomial expansion of the absorptive parts converges. To do this, we refer to our computation of the boundary curves given in Sec. V. First, we must justify our statement that in the region where the cuts overlap, namely from $4\mu^2$ to $4(m^2 - \mu^2)$, the annihilation amplitude for the "crossed" nucleon-antinucleon process can be expanded in Legendre polynomials. This may be readily seen by looking at the expression for \bar{A} given in (5.18). It is necessary to reinterpret the variables so that s in that equation corresponds to t'' in (A.17), and $t \rightarrow s'$. The breakdown of the expansion occurs when either of the curves $(s' - 4m^2)(\bar{t}'' - 4\mu^2) = 4\mu^4$ or $(s' + \bar{t}'')(\bar{t}'' - 4\mu^2) = 4\mu^4$ are intersected by the region of integration in (A.17). Confining ourselves to the overlap interval $4\mu^2 < s' < 4(m^2 - \mu^2)$ we see that the region in (A.17) shown in Fig. 2 is free from singularities, so that the polynomial expansion is legitimate. It is a simple matter to reinterpret these curves in terms of the angular variable \bar{z}'' , but we shall not stop to do so.

In order to attempt an evaluation of I_2 in Eq. (A.12) or (A.14) by means of a Legendre polynomial expansion, we must determine the analyticity properties of $A(s'', t'')$ as a function of t'' . This may be done by finding the region where ρ_{12} and ρ_{13} are different from zero, by means of a calculation analogous to that carried out in Sec. V for A . Thus, according to Eq. (3.13), we must evaluate the absorptive part by retaining the lowest mass intermediate state which in this case is that of

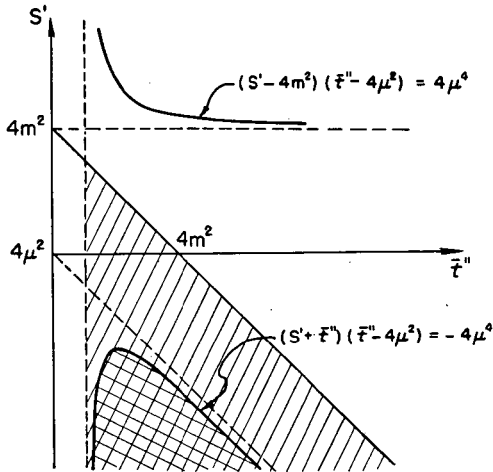

FIG. 2. The region of integration in Eq. (A.17) is shaded. The curve which encloses the double cross-hatched region is the boundary where the Legendre expansion fails. It has its maximum at $s' = -8\mu^2$, $t'' = 6\mu^2$.

two nucleons (the deuteron being treated separately). We find, omitting unimportant factors

$$\langle Q_1 Q_2 | f | P_2 \rangle \sim \frac{1}{(P_1 - Q_1)^2 + \mu^2} \pm \frac{1}{(P_1 - Q_2)^2 + \mu^2}, \quad (\text{A.19})$$

and

$$\langle P_2' | f | Q_1 Q_2 \rangle \sim \frac{1}{(P_1' - Q_1)^2 + \mu^2} \pm \frac{1}{(P_1' - Q_2)^2 + \mu^2}. \quad (\text{A.20})$$

Proceeding through the calculation as in Sec. V, we find finally

$$A(s, \bar{t}, t) \sim \int_0^\infty dt' \frac{\theta[(t' - 4\mu^2)(s - 4m^2) - 4\mu^4]}{t' - t} \pm \int_0^\infty dt'' \frac{\theta[(t'' - 4\mu^2)(s - 4m^2) - 4\mu^4]}{t'' - \bar{t}}. \quad (\text{A.21})$$

The critical values of t'' as a function of the energy variable s'' are given by the equations

$$t'' = 4\mu^2 + 4\mu^4 / (s'' - 4m^2), \quad (\text{A.22})$$

$$t'' = 4(m^2 - \mu^2) - s - 4\mu^4 / (s'' - 4m^2). \quad (\text{A.22})$$

The second restriction is irrelevant since we are only interested in $t'' > 0$. Again, it is quite easy to reinterpret these results in terms of angles, for use in (A.12).

APPENDIX B. THE TWO-MESON CONTRIBUTION IN FOURTH-ORDER

We calculate here the fourth-order contribution to the absorptive part of the nucleon-antinucleon scatter-

ing amplitude. The crossing relations can be used then to obtain the corresponding contribution for the nucleon-nucleon amplitude.

In terms of the invariant amplitudes for nucleon-nucleon annihilation into two pions, the quantities $\mathcal{F}_{\lambda\lambda'}$ which appear in (6.1) can be written in Born approximation as

$$\mathcal{F}_{++} = \mathcal{F}_{--} = (mq/8\pi\bar{E}) \cos\theta_1 B,$$

$$\mathcal{F}_{+-} = - (q/8\pi) \sin\theta_1 e^{-i\phi_1} B, \quad (\text{B.1})$$

$$\mathcal{F}_{-+} = (q/8\pi) \sin\theta_1 e^{i\phi_1} B,$$

and

$$\mathcal{F}_{++}^* = \mathcal{F}_{--}^* = (mq/8\pi\bar{E}) \cos\theta_2 B^*,$$

$$\mathcal{F}_{+-}^* = - \frac{q}{8\pi} \left[\sin\theta_1 e^{i\phi_1} - \frac{\sin\bar{\theta}(\cos\theta_1 + \cos\theta_2)}{1 + \cos\bar{\theta}} \right] B^*, \quad (\text{B.2})$$

$$\mathcal{F}_{-+}^* = \frac{q}{8\pi} \left[\sin\theta_1 e^{-i\phi_1} - \frac{\sin\bar{\theta}(\cos\theta_1 + \cos\theta_2)}{1 + \cos\bar{\theta}} \right] B^*,$$

where

$$B = \left(\frac{\sqrt{6}}{2} \right) \frac{2\pi g^2}{\bar{p}q} \left[\frac{1}{\lambda - z_1} \mp \frac{1}{\lambda - z_2} \right]. \quad (\text{B.3})$$

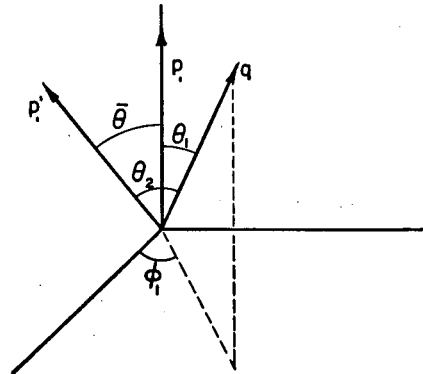

FIG. 3. Coordinate system for evaluation of the two-pion intermediate state contribution to the negative cut.

The relevant angles are shown in Fig. 3. The upper factor and sign refer to $I=0$, the lower to $I=1$. We have written $z_1 = \cos\theta_1$, $z_2 = \cos\theta_2$ and

$$\lambda = \frac{s - 2\mu^2}{4\bar{p}q} = \frac{s - 2\mu^2}{[(s - 4m^2)(s - 4\mu^2)]^{1/2}}. \quad (\text{B.4})$$

Substituting into (6.1) we find

$$\begin{aligned}
 \left(\frac{1/6}{1/4}\right) \operatorname{Im} f_2 &= \frac{g^4 \mu^4 m^2 q}{32\pi \bar{E} \bar{p}^2} \int d\Omega z_1 z_2 \left(\frac{1}{\lambda - z_1} \mp \frac{1}{\lambda + z_1} \right) \left(\frac{1}{\lambda - z_2} \mp \frac{1}{\lambda + z_2} \right) \\
 \left(\frac{1/6}{1/4}\right) \operatorname{Im}(f_3 + f_4) &= \frac{g^4 \mu^4 q \bar{E}}{32\pi \bar{p}^2 (1 + \bar{z})} \int d\Omega \left[\sin^2 \theta_1 - \frac{\sin \bar{\theta} \sin \theta_1 (\cos \theta_1 + \cos \theta_2) e^{-i\phi_1}}{1 + \cos \bar{\theta}} \right] \\
 &\quad \times \left(\frac{1}{\lambda - z_1} \mp \frac{1}{\lambda + z_1} \right) \left(\frac{1}{\lambda - z_2} \mp \frac{1}{\lambda + z_2} \right), \\
 \left(\frac{1/6}{1/4}\right) \operatorname{Im}(f_3 - f_4) &= \frac{g^4 \mu^4 q \bar{E}}{32\pi \bar{p}^2 (1 - \bar{z})} \int d\Omega \left[\sin^2 \theta_1 e^{-2i\phi_1} - \frac{\sin \bar{\theta} \sin \theta_1 (\cos \theta_1 + \cos \theta_2) e^{-i\phi_1}}{1 + \cos \bar{\theta}} \right] \\
 &\quad \times \left(\frac{1}{\lambda - z_1} \mp \frac{1}{\lambda + z_1} \right) \left(\frac{1}{\lambda - z_2} \mp \frac{1}{\lambda + z_2} \right), \\
 \left(\frac{1/6}{1/4}\right) \operatorname{Im} f_5 &= \frac{g^2 \mu^4 m^2 q}{32\pi \bar{p}^2 \bar{E} (1 - \bar{z})^{\frac{1}{2}}} \int d\Omega \left[-\cos \theta_1 \sin \theta_1 e^{i\phi_1} + \frac{\cos \theta_1 \sin \bar{\theta} (\cos \theta_1 + \cos \theta_2)}{1 + \cos \bar{\theta}} \right] \\
 &\quad \times \left(\frac{1}{\lambda - z_1} \mp \frac{1}{\lambda + z_1} \right) \left(\frac{1}{\lambda - z_2} \mp \frac{1}{\lambda + z_2} \right).
 \end{aligned} \tag{B.5}$$

Let us define

$$\begin{aligned}
 T_1 &= \frac{\lambda}{4\pi} \int d\Omega \frac{1}{\lambda - z_1} = \frac{s - 2\mu^2}{[(4m^2 - s)(s - 4\mu^2)]^{\frac{1}{2}}} \\
 &\quad \times \tan^{-1} \frac{[(4m^2 - s)(s - 4\mu^2)]^{\frac{1}{2}}}{s - 2\mu^2}, \\
 T_2 &= \frac{\lambda^2}{4\pi} \int d\Omega \frac{1}{(\lambda - z_1)(\lambda - z_2)} \\
 &= \frac{(s - 2\mu^2)^2}{\{i(s - 4\mu^2)[(s - 2\mu^2)^2 + i(s - 4\mu^2)]\}^{\frac{1}{2}}} \\
 &\quad \times \tan^{-1} \left\{ \frac{i(s - 4\mu^2)}{(s - 2\mu^2)^2 + i(s - 4\mu^2)} \right\}^{\frac{1}{2}}, \\
 T_3 &= \frac{\lambda^2}{4\pi} \int d\Omega \frac{1}{(\lambda + z_1)(\lambda - z_2)} \\
 &= \frac{(s - 2\mu^2)^2}{\{i(s - 4\mu^2)[(s - 2\mu^2)^2 + i(\bar{s} - 4\mu^2)]\}^{\frac{1}{2}}} \\
 &\quad \times \tan^{-1} \left\{ \frac{i(s - 4\mu^2)}{(s - 2\mu^2)^2 + i(s - 4\mu^2)} \right\}^{\frac{1}{2}}.
 \end{aligned} \tag{B.6}$$

These integrals have the following simple form in a static limit: We obtain then

$$\begin{aligned}
 \operatorname{Im} f_2^0 &= \frac{3}{2} (g^4 \mu^4 m^2 q / \bar{E} \bar{p}^2) (2 - 4T_1 + T_2 + T_3), \\
 \operatorname{Im} f_2^1 &= (g^4 \mu^4 m^2 q / \bar{E} \bar{p}^2) (T_2 - T_3), \\
 \operatorname{Im}(f_3^0 + f_4^0) &= \frac{3}{2} \frac{g^4 q \bar{E}}{\bar{p}^2 (1 + \bar{z})} \left[-2 + \frac{4T_1}{1 + \bar{z}} + \left(\frac{\bar{z} - 3}{1 + \bar{z}} + \frac{1}{\lambda^2} \right) T_2 - \left(\frac{1}{\lambda^2} - 1 \right) T_3 \right],
 \end{aligned}$$

static limit:

$$\begin{aligned}
 T_1 &\rightarrow \frac{\pi(s - 2\mu^2)}{4m(s - 4\mu^2)^{\frac{1}{2}}}, \\
 T_2 &\rightarrow \frac{(s - 2\mu^2)^2}{4m^2(s - 4\mu^2)}, \\
 T_3 &\rightarrow \frac{(s - 2\mu^2)^2}{4m^2(s - 4\mu^2)}.
 \end{aligned} \tag{B.7}$$

Also, near the two-meson threshold, the following expansions are of interest:

$$\begin{aligned}
 T_1 &= 1 + \frac{1}{3\lambda^2} + \frac{1}{5\lambda^4} + \dots, \\
 T_2 &= 1 + \frac{2 + \bar{z}}{3\lambda^2} + \frac{7 + 6\bar{z} + 2\bar{z}^2}{15\lambda^4} + \dots, \\
 T_3 &= 1 + \frac{(2 - \bar{z})}{3\lambda^2} + \frac{7 - 6\bar{z} + 2\bar{z}^2}{15\lambda^4} + \dots.
 \end{aligned} \tag{B.8}$$

$$\begin{aligned}
 \text{Im}(f_3^1 + f_4^1) &= \frac{g^4 q \bar{E}}{\bar{p}^2(1+\bar{z})} \left[\frac{4T_1}{1+\bar{z}} + \left(\frac{\bar{z}-3}{1+\bar{z}} + \frac{1}{\lambda^2} \right) T_2 + \left(\frac{1}{\lambda^2} - 1 \right) T_3 \right], \\
 \text{Im}(f_3^0 - f_4^0) &= \frac{3}{2} \frac{g^4 \mu^4 q \bar{E}}{\bar{p}^2(1-\bar{z})} \left[-2 + \frac{4}{1-\bar{z}} T_1 + \left(1 - \frac{1}{\lambda^2} \right) T_2 + \left(\frac{-\bar{z}-3}{1-\bar{z}} + \frac{1}{\lambda^2} \right) T_3 \right], \\
 \text{Im}(\bar{f}_3^1 - f_4^1) &= \frac{g^4 \mu^4 q \bar{E}}{\bar{p}^2(1-\bar{z})} \left[-\frac{4T_1}{1-\bar{z}} + \left(1 - \frac{1}{\lambda^2} \right) T_2 - \left(\frac{-\bar{z}-3}{1-\bar{z}} + \frac{1}{\lambda^2} \right) T_3 \right], \\
 \text{Im}f_6^0 &= \frac{3}{2} \frac{g^4 \mu^4 m^2 q}{\bar{p}^2 \bar{E}} \left[\frac{2\bar{z}}{1-\bar{z}^2} T_1 + \frac{1}{1+\bar{z}} T_2 - \frac{1}{1-\bar{z}} T_3 \right], \\
 \text{Im}f_6^1 &= \frac{g^4 \mu^4 m^2 q}{\bar{p}^2 \bar{E}} \left[-\frac{2}{1-\bar{z}^2} T_1 + \frac{1}{1+\bar{z}} T_2 + \frac{1}{1-\bar{z}} T_3 \right].
 \end{aligned} \tag{B.9}$$

In order to compare with the partial wave expansion, we make use of the Born approximation to the quantities b_{\pm} which appear in (6.3):

$$\begin{aligned}
 (1/\sqrt{6})b_+^0 &= g^2 \mu^2 m Q_1(\lambda), \\
 \left(\frac{1/\sqrt{6}}{1/2} \right) (\bar{p}q)^J b_+^J &= g^2 \mu^2 m \lambda Q_J(\lambda), \\
 \left(\frac{1/\sqrt{6}}{1/2} \right) (\bar{p}q)^J b_-^J &= g^2 \mu^2 \frac{[J(J+1)]^{\frac{1}{2}}}{2J+1} \\
 &\quad \times [Q_{J-1}(\lambda) - Q_{J+1}(\lambda)],
 \end{aligned} \tag{B.10}$$

where the Q 's are Legendre functions of the second kind. Substituting into (6.1) and making an expansion in powers of $1/\lambda$ (near threshold), it is not too difficult to check that it agrees with the corresponding expansions of (B.9).

APPENDIX C. VARIATIONAL METHOD FOR THE N AND D EQUATIONS

The most familiar method for solving the Fredholm equation (7.6) is by iteration. However, the convergence of the series thus obtained depends on the magnitude of the source function. In many instances of interest the series fails to converge as is the case when bound states are present. A numerical integration of the equation is possible to any desired degree of approximation by replacing the integral by a finite sum and solving a system of linear algebraic equations. It may, however, be useful to handle the equations by variational methods. In this appendix, such a variational approach is developed which is valid also for the multichannel case.

Let us make a subtraction in (7.4, 5) at some value $\nu = \bar{\nu}$. We obtain

$$\begin{aligned}
 N(\nu) &= N(\bar{\nu}) + (\nu - \bar{\nu}) \int_{-\infty}^{-\nu_0} \alpha(\nu') D(\nu') \\
 &\quad \times \frac{d\nu'}{(\nu' - \nu)(\nu' - \bar{\nu})}, \tag{C.1}
 \end{aligned}$$

$$\begin{aligned}
 D(\nu) &= D(\bar{\nu}) - \frac{(\nu - \bar{\nu})}{\pi} \int_0^{\infty} \left(\frac{\nu'}{\nu' + m^2} \right)^{\frac{1}{2}} N(\nu') \\
 &\quad \times \frac{d\nu'}{(\nu' - \nu)(\nu' - \bar{\nu})}. \tag{C.2}
 \end{aligned}$$

Replacing $N(\nu')$ in (C.2) by the expression (C.1), interchanging the order of integrations, and making $\nu \rightarrow -\nu$, we obtain

$$\begin{aligned}
 D(-\nu) &= D(\bar{\nu}) + N(\bar{\nu}) [\gamma(\nu) - \gamma(-\bar{\nu})] \\
 &\quad + (\nu + \bar{\nu}) \int_{\nu_0}^{\infty} \alpha(-\nu') D(-\nu') K(\nu', \nu) \frac{d\nu'}{\nu' + \bar{\nu}}, \tag{C.3}
 \end{aligned}$$

where

$$\begin{aligned}
 K(\nu', \nu) &= \frac{1}{\pi} \int_0^{\infty} \left(\frac{\nu''}{\nu'' + m^2} \right)^{\frac{1}{2}} \frac{d\nu''}{(\nu'' + \nu')(\nu'' + \nu)} \\
 &= \frac{\gamma(\nu') - \gamma(\nu)}{\nu' - \nu}. \tag{C.4}
 \end{aligned}$$

Multiplying both sides of (C.3) on the left, by $D(-\nu)^T \alpha(-\nu)/(\nu + \bar{\nu})^2$ and integrating, one obtains

$$\mathcal{L}(\bar{\nu}) N(\bar{\nu}) = \mathcal{R}(\bar{\nu}), \tag{C.5}$$

where:

$$\begin{aligned}
 \mathcal{L}(\bar{\nu}) &= \int_{\nu_0}^{\infty} D(-\nu)^T \alpha(-\nu) D(\bar{\nu}) N(\bar{\nu})^{-1} \frac{d\nu}{(\nu + \bar{\nu})^2} \\
 &\quad + \int_{\nu_0}^{\infty} D(-\nu)^T \alpha(-\nu) K(\nu, \bar{\nu}) \frac{d\nu}{\nu + \bar{\nu}} \\
 &= \int_{\nu_0}^{\infty} D(-\nu)^T \alpha(-\nu) \eta(\bar{\nu}) \frac{d\nu}{(\nu + \bar{\nu})^2} \\
 &\quad + \int_{\nu_0}^{\infty} D(-\nu)^T \alpha(-\nu) \gamma(\nu) \frac{d\nu}{(\nu + \bar{\nu})^2} \\
 &= L_1^T \eta(\bar{\nu}) + L_2^T, \tag{C.6}
 \end{aligned}$$

In the first integral we substitute $\cos\theta=1+t/2p^2$ and in the second $\cos\theta=-1-\bar{t}/2p^2$, and we change the variable of integration to $2p^2(\eta-1)$. We have then, evaluating the limits in terms of s ,

$$\bar{A} = \int_0^\infty dt' \frac{\theta[(t'-4m^2)(s-4\mu^2)-4\mu^4]}{(t'-t)[1+t'/2p^2]} \pm \int_0^\infty d\bar{t}' \frac{\theta[(\bar{t}'-4m^2)(s-4\mu^2)-4\mu^4]}{(\bar{t}'-\bar{t})[1+\bar{t}'/2p^2]}. \quad (5.18)$$

The θ functions define the regions' in the (s, t) and (s, \bar{t}) space where the weight functions $\bar{\rho}_{13}(s, t)$ and $\bar{\rho}_{12}(s, \bar{t})$ in (3.4) are different from zero. The critical values of $z = \cos\theta$ for which \bar{A} becomes complex and the Legendre expansion breaks down, are found by setting $t = -2p^2(1-z)$, $\bar{t} = -2p^2(1+z)$ equal to the boundary curves given by the θ functions. This leads to

$$z = -1 + [4m^2 + 4\mu^4/(s-4\mu^2)]/2(\frac{1}{4}s - m^2) \quad t' = t, \quad (5.19a)$$

$$z = -1 - [4m^2 + 4\mu^4/(s-4\mu^2)]/2(\frac{1}{4}s - m^2) \quad \bar{t}' = \bar{t}. \quad (5.19b)$$

$$\int_{4\mu^2}^{4m^2} d\bar{t}' \int_{-1}^1 d\bar{z} - \int_{4m^2}^\infty dz' \int_1^\infty d\bar{z} = \left[\int_{4\mu^2}^{4m^2} d\bar{t}' \int_{z_1(s)}^1 d\bar{z} - \int_{4m^2}^\infty dz' \int_1^{\bar{z}_2(s)} d\bar{z} \right] (\text{expansion valid}) + \left[\int_{4\mu^2}^{4m^2} d\bar{t}' \int_{-\infty}^{\bar{z}_1(s)} d\bar{z} - \int_{4m^2}^\infty d\bar{t}' \int_{z_2(s)}^\infty d\bar{z} \right] (\text{expansion not valid}). \quad (5.21)$$

If we wish to use Eq. (5.13) in place of (5.12), we may use the boundary curves in terms of momentum transfer, directly given in (5.18). Transforming to the variables appropriate to (5.13), namely $s \rightarrow t'$ the energy variable, we have the conditions $t' = [4m^2 + 4\mu^4/(t'-4\mu^2)]$ and $\bar{t}' = [-\bar{t}' - 4\mu^4/(\bar{t}' - 4\mu^2)]$. Again the second condition is irrelevant, since we are concerned only with $t' > 0$. Evidently the t' integral may be broken up into two regions, namely $0 < t' < [4m^2 + 4\mu^4/(t'-4\mu^2)]$ where a Legendre expansion converges, and $[4m^2 + 4\mu^4/(t'-4\mu^2)] < t' < \infty$ where it diverges.

Barring a complete solution of the nucleon-antinucleon amplitude problem, we will be forced in practice to neglect the contributions from the regions where the expansion is not valid, or else perform some approximate evaluation of their magnitude, based on other considerations. We return to this point in Sec. VI.

VI. LOW-MASS CONTRIBUTIONS

In the next section we shall show how the partial wave dispersion relations can be used as dynamical equations for the determination of the low angular momentum amplitudes. In this approach, we shall make extensive use of the unitarity condition which, along the right-hand cut, takes the form

$$\text{Im}f^J = \sum_n |f_n^J|^2 \rho_n,$$

the summation extending over all allowed channels

The first of these is shown in Fig. 1. The regions above curve (1) and below curve (2) are the allowed ones. The second condition is simply the reflection of these curves in the s axis. The maximum of curve (1) occurs at $s = 6\mu^2 - \mu^4/m^2$ and the value of z at this point is given by

$$z = - \left[1 + \frac{3\mu^2}{2m^2} - \frac{2\mu^4}{m^4} - \frac{\mu^6}{2m^6} \right] / \left[1 - \frac{5\mu^2}{2m^2} + \frac{2\mu^4}{m^4} - \frac{\mu^6}{2m^6} \right] \simeq -1 - 4\mu^2/m^2. \quad (5.20)$$

With these facts in mind we return to Eq. (5.11). It is easy to check that condition (5.19b) puts no restriction on the polynomial expansion, whereas (5.19a) does. Referring to curve (1) as $\bar{z}_1(s)$ and curve (2) as $\bar{z}_2(s)$, we see that the region of integration may be broken up further into sub-regions where the expansion is, or is not valid.

compatible with conservation laws. Here ρ_n is a phase space factor. Furthermore, on the grounds that the behavior of the amplitudes in a low-energy range is mostly affected by the nearby singularities, we shall ignore production processes and use the unitarity condition as if nucleon-nucleon scattering were elastic at all energies.

Just below the beginning of the right-hand cut, the deuteron pole may be present, depending on the particular state we are considering. As we shall show, the parameters which define it (residue and location) can be calculated in principle. In practice, we may want to take these quantities as given, but at any rate its handling present no difficulty.

On the left-hand cut the situation is considerably more involved. The first singularity one encounters is that associated with the one pion state which, as discussed before, gives rise to a branch cut running from $4m^2 - \mu^2$ to $-\infty$ along the real s axis. With the pion mass and the pion-nucleon coupling constant given, the contribution of this state can be explicitly calculated. For the determination of the remaining singularities we must turn to nucleon-antinucleon scattering.

In principle, the partial wave dispersion relations for this process could be used. On the positive cut we would make use of unitarity (extended into the unphysical region to the point where the nucleon-antinucleon pair has total energy equal to 2μ); on the negative cut, we would in principle have to use some information about

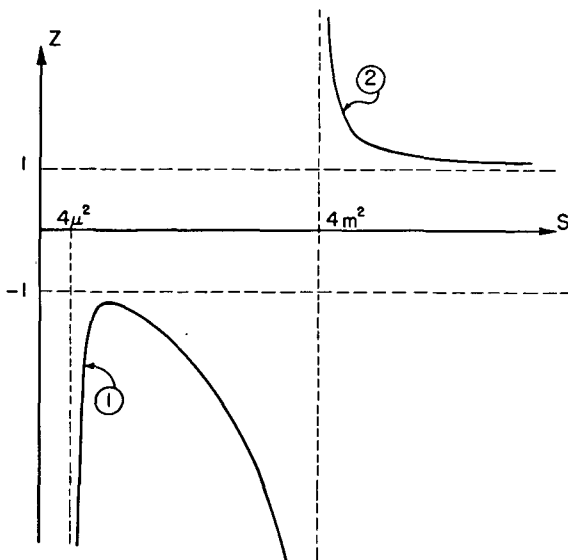

FIG. 1. Curves showing the domain of validity of the Legendre polynomial expansion of the nucleon-antinucleon amplitude. The allowed region is that above curve 1 and below curve 2. Outside this region the expansion definitely diverges.

nucleon scattering. We would thus be led to a very complicated set of coupled integral equations which, if solved, would give us the desired answers for both nucleon-nucleon and nucleon-antinucleon scattering. In practice the task is almost hopeless. In making use of unitarity, we could not possibly neglect inelastic processes in the physical region; nucleon-antinucleon scattering is violently inelastic and besides, if we wish to continue the amplitude below the physical threshold we must take account of precisely these inelastic processes, at least those which involve nucleon-antinucleon annihilation into up to 13 mesons.

Returning to the nucleon-nucleon problem, the first singularity we encounter on the negative cut beyond the one meson branch point, is the two meson singularity. In the region between $(4m^2 - 4\mu^2)$ and $(4m^2 - 9\mu^2)$ on the real s axis, there are no other singularities and one might hope that, if the idea that only nearby singularities are important is correct, it might be permissible to restrict oneself to the one and two pion contributions on the left-hand cut.

The two pion contribution to the absorptive part can be calculated if one knows the nucleon-antinucleon annihilation amplitude into two pions, extended into the unphysical energy region for this process. Although this amplitude is not exactly known at present, it might be worthwhile to use such results as obtained by Frazer and Fulco^{11,14} in order to find out what consequences they entail in nucleon-nucleon scattering. Let us remark that, consistent with our approximation of neglecting higher singularities, we expect the main contribution to come from the nucleon-antinucleon energy region near $4\mu^2$. For the partial waves in the lower

angular momentum states ($J=0, 1$) we would take the Frazer and Fulco solution, modified by a normalization procedure which will be described by Ball and Wong in a future paper.¹⁵ Higher partial waves may be considered in Born approximation; this will lead essentially to the fourth-order contribution to the nucleon-nucleon amplitude for these higher waves. To this effect, we take the full Born approximation to the annihilation amplitude, subtract the lower angular momentum, and replace the subtracted parts by the explicit solutions mentioned above.

As discussed at the end of Sec. V, we can obtain the imaginary parts of the amplitudes f in the unphysical region by relating them, via the crossing relations (4.30) and (4.33), to the imaginary parts of the corresponding amplitudes \bar{f} for the nucleon-antinucleon process. The contribution to the imaginary parts of these amplitudes, due to the two meson intermediate state, are related through the unitarity condition [see also the definition of \mathcal{G}_{II} in (3.15)], to the amplitude for nucleon-antinucleon annihilation into two pions as follows:

$$\text{Im}f_1 = 0,$$

$$\text{Im}f_2 = \frac{q\bar{E}}{2\pi} \int d\Omega (\mathcal{F}_{++}\mathcal{F}_{++}^*),$$

$$\text{Im}(f_3 + f_4) = \frac{q\bar{E}}{2\pi(1+\bar{z})} \int d\Omega (\mathcal{F}_{+-}\mathcal{F}_{+-}^*), \quad (6.1)$$

$$\text{Im}(\bar{f}_3 - \bar{f}_4) = \frac{-q\bar{E}}{2\pi(1-\bar{z})} \int d\Omega (\mathcal{F}_{+-}\mathcal{F}_{+-}^*),$$

$$\text{Im}\bar{f}_5 = \frac{qm}{2\pi(1-\bar{z}^2)^{1/2}} \int d\Omega (\mathcal{F}_{++}\mathcal{F}_{++}^*),$$

where $\mathcal{F}_{\lambda\lambda'}$ are the annihilation amplitudes defined by Frazer and Fulco.¹¹ Here $q = (s/4 - \mu^2)^{1/2}$ denotes the momentum of one of the mesons in the center-of-mass system for the annihilation process, the integration is over the directions of \hat{q} , and we have written

$$s/4 = \bar{E}^2 = q^2 + \mu^2 = \bar{p}^2 + m^2, \quad \bar{z} = \cos\hat{\theta} + 1 + 2t/(s - 4m^2).$$

Of course, unitarity implies that Eqs. (6.1) are valid for $s > 4m^2$ only, but the extension into the region below $4m^2$ can be justified.¹⁶ In the Appendix we illustrate such continuation by calculating the fourth-order perturbation theory contribution. Since the exact quantities differ from the fourth-order parts only in the weight functions which appear in the Mandelstam representation, functions which are real, the result we obtain is valid in general.

Let us now give the partial wave expansion of the right-hand side of (6.1). We will then state the correct analytic continuation and again, in Appendix B, verify

¹⁵ J. S. Ball and D. Y. Wong (to be published).

¹⁶ S. Mandelstam, Phys. Rev. Letters 4, 84 (1960).

¹⁴ W. R. Frazer and J. R. Fulco, Phys. Rev. 117, 1609 (1960).

it for the fourth-order case. According to Frazer and Fulco (note the slight change of notations)

$$\begin{aligned} \mathfrak{F}_{++} &= \sum (J + \frac{1}{2}) [(\bar{p}q)^J / \bar{p}\bar{E}] b_+^J(s) d_{00}^J(\bar{\theta}), \\ \mathfrak{F}_{+-} &= -\mathfrak{F}_{-+} = -\sum (J + \frac{1}{2}) [(\bar{p}q)^J / \bar{p}] b_-^J(s) d_{10}^J(\bar{\theta}). \end{aligned} \quad (6.2)$$

Substituting into (6.1), we obtain

$$\begin{aligned} \text{Im} \bar{f}_1 &= 0, \\ \text{Im} \bar{f}_2 &= (q/2\bar{p}^2\bar{E}) \sum (2J+1) (\bar{p}q)^{2J} |b_+^J|^2 d_{00}^J(\bar{\theta}), \\ \text{Im}(\bar{f}_3 + \bar{f}_4) &= [q\bar{E}/2\bar{p}^2(1+\bar{z})] \sum (2J+1) \\ &\quad \times (\bar{p}q)^{2J} |b_-^J|^2 d_{11}^J(\bar{\theta}), \\ \text{Im}(\bar{f}_3 - \bar{f}_4) &= [-q\bar{E}/2\bar{p}^2(1-\bar{z})] \sum (2J+1) \\ &\quad \times (\bar{p}q)^{2J} |b_-^J|^2 d_{1-1}^J(\bar{\theta}), \\ \text{Im} \bar{f}_5 &= [qm/2\bar{p}^2\bar{E}(1-\bar{z}^2)^{\frac{1}{2}}] \sum (2J+1) \\ &\quad \times (\bar{p}q)^{2J} |b_+^J b_-^J| d_{01}^J(\bar{\theta}). \end{aligned} \quad (6.3)$$

Here, the absolute value sign means that we must take the analytic continuation of bb^* from the region $s > 4m^2$. In the perturbation calculation the b 's are real, and the absolute value sign is superfluous. Let us point out, however, that a certain amount of care is required when using the quantities T_{\pm}^J of Frazer and Fulco^{11,14} given by

$$T_+^J = [q(\bar{p}q)^J / \bar{p}\bar{E}] b_+^J, \quad T_-^J = [q(\bar{p}q)^J / \bar{p}] b_-^J. \quad (6.4)$$

In continuing these quantities into the region $4\mu^2 < s < 4m^2$ we must replace $|T_{\pm}^J|^2$ by $(-1)^{J-1} |T_{\pm}^J|^2$ since, in this region, \bar{p} is imaginary.

Using the crossing relations for the f 's and projecting out individual angular momenta, we can easily obtain the contributions to the imaginary parts of the partial wave amplitudes. Since the final expressions are rather long, we shall not write them explicitly.

Before concluding this section, let us write down the one-pion and deuteron terms. The one-pion state gives the following contribution to the Feynman amplitude for nucleon-nucleon scattering [written in the representation (2.3)]:

$$\begin{aligned} \mathfrak{T}_1(1 \text{ pion}) &= 3g^2 \left(\frac{P}{\mu^2-t} + \frac{\bar{P}}{\mu^2-\bar{t}} \right) \mathcal{P}_0 \\ &\quad - g^2 \left(\frac{P}{\mu^2-t} - \frac{\bar{P}}{\mu^2-\bar{t}} \right) \mathcal{P}_1. \end{aligned} \quad (6.5)$$

The contributions to the covariant functions are therefore

$$\begin{aligned} G_1^0 &= -3G_2^1 = -G_3^0 = 3G_4^1 = G_5^0 \\ &= \frac{3g^2}{8\pi} \left(\frac{1}{\mu^2-t} - \frac{1}{\mu^2-\bar{t}} \right) \\ (1 \text{ pion}) \quad -3G_1^1 &= G_2^0 = 3G_3^1 = -G_4^0 = -3G_5^1 \\ &= \frac{3g^2}{8\pi} \left(\frac{1}{\mu^2-t} + \frac{1}{\mu^2-\bar{t}} \right). \end{aligned} \quad (6.6)$$

Finally, the contributions to the f 's are given by

$$\begin{aligned} f_1^0 &= -f_2^0 = -\frac{3g^2}{16\pi} \left(\frac{t}{\mu^2-t} - \frac{\bar{t}}{\mu^2-\bar{t}} \right), \\ f_1^1 &= -f_2^1 = \frac{g^2}{16\pi} \left(\frac{t}{\mu^2-t} + \frac{\bar{t}}{\mu^2-\bar{t}} \right), \\ (1 \text{ pion}) \quad f_3^0 &= 3f_4^1 = \frac{3g^2}{8\pi} \left(\frac{p^2}{\mu^2-t} - \frac{p^2}{\mu^2-\bar{t}} \right), \\ 3f_3^1 &= f_4^0 = -\frac{3g^2}{8\pi} \left(\frac{p^2}{\mu^2-t} + \frac{p^2}{\mu^2-\bar{t}} \right), \\ f_5^0 &= f_5^1 = 0. \end{aligned} \quad (6.7)$$

To avoid any possible confusion about normalization, we remark that $g^2/4\pi \simeq 15$.

According to Blankenbecler, Goldberger, and Halpern,¹⁷ the deuteron state makes a contribution in the $I=0, J=1$ part of the Feynman amplitude of the form $R/(s-m_D^2)$ where

$$\begin{aligned} R &= \sum_{\xi} \bar{u}(P_2') [\mathfrak{F}i\gamma \cdot \xi + \mathfrak{G}P_2' \cdot \xi] C \bar{u}(P_1') u(P_1) C^{-1} \\ &\quad \times [\mathfrak{F}i\gamma \cdot \xi^* + \mathfrak{G}P_2 \cdot \xi^*] u(P_2), \end{aligned} \quad (6.8)$$

ξ is a complex unit pseudovector describing the deuteron polarization, which satisfies $\xi \cdot (P_2 - P_1) = 0$, \mathfrak{F} and \mathfrak{G} are real. The summation over ξ leads to

$$\begin{aligned} R &= \mathfrak{F}^2 \bar{u}(P_2') \gamma_{\mu} C \bar{u}(P_1') u(P_1) C^{-1} \gamma_{\mu} u(P_2) - \frac{1}{4} \mathfrak{G}^2 (P_2' - P_1') \\ &\quad \cdot (P_2 - P_1) \cdot \bar{u}(P_2') C \bar{u}(P_1') u(P_1) C^{-1} u(P_2) \\ &\quad - \mathfrak{F} \mathfrak{G} \{ \bar{u}(P_2') i\gamma \cdot P_2 C \bar{u}(P_1') u(P_1) C^{-1} u(P_2) \\ &\quad + \bar{u}(P_2') C \bar{u}(P_1') u(P_1) C^{-1} i\gamma \cdot P_2' u(P_2) \}, \end{aligned} \quad (6.9)$$

and the following contributions to the covariant functions:

$$\begin{aligned} G_1^0 &= -(\mathfrak{p}^2/2\pi m) \mathfrak{F} \mathfrak{G} / (s-m_D^2), \\ G_2^0 &= -(E^2/2\pi m) \mathfrak{F} \mathfrak{G} / (s-m_D^2), \\ (\text{deuteron}) \quad G_3^0 &= 0, \\ G_4^0 &= (1/2\pi) \mathfrak{F} (\mathfrak{F} + m\mathfrak{G}) / (s-m_D^2), \\ G_5^0 &= -(\mathfrak{p}^2/2\pi m) \mathfrak{G} (\mathfrak{F} + m\mathfrak{G}) / (s-m_D^2). \end{aligned} \quad (6.10)$$

The contributions to the f 's are

$$\begin{aligned} f_1^0 &= 0, \\ f_2^0 &= (z/2\pi) (m\mathfrak{F} - \mathfrak{p}^2 \mathfrak{G})^2, \\ (\text{deuteron}) \quad f_3^0 &= 0, \\ f_4^0 &= (E^2/2\pi) \mathfrak{F}^2, \\ f_5^0 &= -(m/2\pi) \mathfrak{F} (m\mathfrak{F} - \mathfrak{p}^2 \mathfrak{G}). \end{aligned} \quad (6.11)$$

Finally, let us quote the relations between the quantities \mathfrak{F} and \mathfrak{G} , and the nonrelativistic parameters defined in G.N.O.,

$$\begin{aligned} \mathfrak{F} &= 4(\pi\alpha)^{\frac{1}{2}} (1+\rho/\sqrt{2}) [m(1-\alpha r_e)(1+\rho^2)]^{-\frac{1}{2}}, \\ \mathfrak{G} &= -6(2\pi/\alpha)^{\frac{1}{2}} m\rho [m(1-\alpha r_e)(1+\rho^2)]^{-\frac{1}{2}}, \end{aligned} \quad (6.12)$$

¹⁷ R. Blankenbecler, M. L. Goldberger, and F. R. Halpern, Nuclear Phys. 12, 629 (1959).

where ρ is the asymptotic d to s -state ratio for the deuteron wave function and $\alpha^2 = m \times$ (binding energy). r_e is the effective range as defined in G.N.O.

VII. DETERMINATION OF THE PARTIAL WAVE AMPLITUDES FROM THE DISPERSION RELATIONS

We turn now to the method of solution of the partial wave dispersion relations. As we have mentioned before, we shall make extensive use of the unitarity condition for the partial wave amplitudes in an approximate form, by neglecting inelastic processes.

Let us consider first transitions in states with $J=l$, for which $f^J = e^{i\delta_J} \sin \delta_J$, the phase shift being real in our approximation. The functions $h(\nu) = [(\nu+m^2)/\nu]^{\frac{1}{2}} f^J(\nu)$ where ν is the square of the momentum in the center-of-mass system, $\nu = p^2 = (s/4 - m^2)$, are analytic in the ν -plane cut on the real axis in the intervals $(-\infty, -\nu_0)$ and $(0, \infty)$ where $\nu_0 = \mu^2/4$. In addition, they have the following properties:

- (i) $h(\nu)^* = h(\nu^*)$,
- (ii) For $-\infty < \nu < \nu_0$, $\text{Im} h(\nu) = \pi \alpha(\nu)$ where $\alpha(\nu)$ is assumed to be a known function of ν . In our approximation, $\alpha(\nu)$ is given by the one- and two-pion contributions to the absorptive part.
- (iii) For $0 < \nu < \infty$ $\text{Im} h(\nu) = [\nu/(\nu+m^2)]^{\frac{1}{2}} |h(\nu)|^2$ or, equivalently, $\text{Im}(1/h) = -[\nu/(\nu+m^2)]^{\frac{1}{2}}$.

We write, following Chew and Mandelstam,¹²

$$h(\nu) = N(\nu)/D(\nu), \quad (7.1)$$

where $N(\nu)$ is analytic in the ν plane except for the branch cut from $-\infty$ to $-\nu_0$ while $D(\nu)$ is analytic except for the branch cut from 0 to ∞ . The deuteron pole, for the $J=1, I=0$ amplitude, which could be incorporated in $N(\nu)$, will be discussed later on, when we shall argue that it may correspond to a zero of $D(\nu)$. The discontinuities of N and D across the respective cuts are given by

$$N(\nu+i\epsilon) - N(\nu-i\epsilon) = 2i \text{Im} h(\nu) D(\nu) \\ = 2\pi i \alpha(\nu) D(\nu) \quad (\nu \leq -\nu_0), \quad (7.2)$$

$$D(\nu+i\epsilon) - D(\nu-i\epsilon) = -2i \left(\frac{\nu}{\nu+m^2} \right)^{\frac{1}{2}} N(\nu) \quad (\nu > 0). \quad (7.3)$$

These conditions alone are not sufficient to determine $h(\nu)$ completely. One must also specify the asymptotic behavior of N and D for large ν . The lack of knowledge of this behavior in field theory, leads to the well-known Castillejo, Dalitz, and Dyson ambiguity.¹⁸ In connection with the Low equations, where this kind of ambiguity also arises, it has been argued that the physical solution is the one that corresponds to the iteration solution of the equation, the expansion in power series in the coupling constant. One can state this argument

more generally in such a way that it applies to the present situation, by requiring that the physical solution contain no undetermined parameters once the masses and coupling constants have been specified; the precise content of this statement will become clear later. If it is at all possible to find a solution satisfying this criterion, we will assume it to be the physical solution.

Analytically, any solution satisfying (7.2) and (7.3) may contain zeros in $D(\nu)$, which are poles of $h(\nu)$. In nonrelativistic potential scattering, where the physical solution is obtained by making $D(\nu) \rightarrow 1$ at infinity, the zeros of $D(\nu)$ correspond to bound states of the system. In field theory, any bound state gives rise to a pole in the scattering amplitude for the corresponding angular momentum, when continuation in the energy is effected below the threshold for the scattering process. In the present problem, we would like to allow for the existence of one pole in the amplitude for the $J=1, I=0$ state, but nowhere else.

At the present stage of development of axiomatic field theory, one cannot distinguish between elementary and composite particles. To each stable particle is associated a field which asymptotically satisfies a free-field equation corresponding to the given mass of the particle. In such an approach, the possibility of calculating the binding energy of particles like the deuteron is precluded. On the other hand, in the usual Lagrangian formalism a distinction is made between elementary and composite particles, since the Lagrangian depends exclusively on the fields describing the former. In this case, one must be able to compute the binding energy of the latter. In our approach, this is possible only if we think of the deuteron pole as arising from the vanishing of $D(\nu)$ at the proper place.

Physically, we would like to picture the situation as follows: for sufficiently small coupling constant, the scattering amplitude has no bound-state poles. As the strength of the interaction is increased, a pole should appear just below the physical threshold and move down, with increasing binding energy, until the correct location is reached for the physical value of the coupling constant. This singularity in the scattering amplitude could be obtained if $D(\nu)$ develops a zero. Examples for special models, or nonrelativistic potential scattering, indicate that this in fact happens.

Let us write now representations for N and D which display the assumed analyticity properties. $h(\nu)$ does not necessarily vanish at infinity and subtractions are required. We shall make one subtraction, and argue then that this is the maximum we can allow. We normalize for convenience $D(0) = 1$, and obtain

$$N(\nu) = h(0) + \nu \int_{-\infty}^{-\nu_0} \alpha(\nu') D(\nu') \frac{d\nu'}{\nu'(\nu'-\nu)}, \quad (7.4)$$

$$D(\nu) = 1 - \frac{\nu}{\pi} \int_0^{\infty} \left(\frac{\nu'}{\nu'+m^2} \right)^{\frac{1}{2}} N(\nu') \frac{d\nu'}{\nu'(\nu'-\nu)}. \quad (7.5)$$

¹⁸ L. Castillejo, R. H. Dalitz, and F. J. Dyson, Phys. Rev. **101**, 453 (1956).

It will be shown later that the scattering length can be determined in principle, in terms of the source function $\alpha(\nu)$. If, however, we perform more subtractions, the new parameters thereby introduced cannot be calculated. Therefore the representations (7.4) and (7.5) satisfy the criterion we have adopted for the physical solution. We remark that on the positive axis the amplitudes are certainly bounded for finite values of the energy. Our criterion corresponds to the assumption that this is the case everywhere in the complex plane. Let us also note that for $J=l>0$, $h(0)=0$.

Substituting (7.4) into (7.5) and interchanging the order of integration we obtain

$$D(-\nu) = 1 + h(0)\gamma(\nu) + \nu \int_{\nu_0}^{\infty} \alpha(-\nu') D(-\nu') \frac{\gamma(\nu') - \gamma(\nu)}{\nu' - \nu} \frac{d\nu'}{\nu'}, \quad (7.6)$$

where

$$\gamma(\nu) = - \left(\frac{\nu}{\nu - m^2} \right)^{\frac{1}{2}} \ln \frac{[\nu/(\nu - m^2)]^{\frac{1}{2}} + 1}{[\nu/(\nu - m^2)]^{\frac{1}{2}} - 1}. \quad (7.7)$$

In Appendix C we shall discuss a variational method of solution of such equations. Once D is known, we can calculate N and obtain finally $h(\nu)$ for the case $J=l$.

Let us now consider the scattering amplitudes in the triplet states with $J \neq 1$. We follow here a proposal by Bjorken which extends the method we have described to the case of many channel reactions.

Consider the submatrix $f = \|f_{ij}\|$ of the scattering matrix which describes a many channel process like triplet nucleon-nucleon scattering for instance. The unitarity relation in the physical region may be written in matrix form:

$$\text{Im}f = f^\dagger \rho f, \quad (7.8)$$

where ρ , which gives the density of intermediate states, is diagonal. Due to time reversal invariance f is symmetric so that we have $f^\dagger = f^*$. Now we write

$$h = [(\nu + m^2)/\nu]^{\frac{1}{2}} f = ND^{-1},$$

where N and D are matrices whose elements have analytic properties analogous to those described before, namely, $N(\nu)$ is analytic in the ν -plane cut from $-\infty$ to $-\nu_0$ and $D(\nu)$ is analytic in the ν plane with a branch cut from 0 to ∞ . Since f_{11}^J and f_{22}^J are odd functions of E and f_{12}^J is even one cannot in defining $h(\nu)$ eliminate all kinematical singularities. In our present definition h_{12} has a purely kinematical branch point at $E=0$. The discontinuity of N and D across the cut are given as before by (7.2, 3) provided we interpret these as matrix relations. {In our particular problem $\rho = [\nu/(\nu + m^2)]^{\frac{1}{2}}$ for the h 's.} Therefore we can write down representations for N and D in the form (7.4, 5) and an equation for D like (7.6). (Since we are dealing with matrices the order αD must always be preserved.) One can easily show that if $h(0)$ and the source functions $\alpha(\nu)$ are symmetric as they should then $h(\nu)$ ob-

tained by solving the equations comes out symmetric. The variational method discussed in Appendix C applies also to this system of coupled equations.

In the states of angular momentum $J=1$ and isotopic spin $I=0$ the triplet amplitudes shall have a pole corresponding to the deuteron bound state. According to our earlier discussion we conjecture that this pole might not be explicitly introduced as a singularity in N but will rather appear as a singularity of D^{-1} in the formal solution of the equation for D . Let us write:

$$D^{-1} = C / (\det D) \quad (7.9)$$

where the elements of C are in general homogeneous polynomials in terms of the elements of D . In the present case:

$$C = \begin{vmatrix} D_{22} & -D_{12} \\ -D_{21} & D_{11} \end{vmatrix}. \quad (7.10)$$

Then a pole of D^{-1} corresponds to a zero of $\det D$. One expects that only one of the eigenstates of the T matrix has a pole. This actually happens if $\det D$ has a simple zero. We then have:

$$\det h = (\det N)(\det D^{-1}) = (\det N) / (\det D). \quad (7.11)$$

If h is diagonalized this shows that only one element has a simple pole, the other is regular. One can then deduce the following relation between the residues of the triplet amplitudes:

$$(f_{11}^1)_R (f_{22}^1)_R = (f_{12}^1)_R^2. \quad (7.12)$$

Computing these residues from (6.11) one obtains:

$$\begin{aligned} (f_{11}^1)_R &= \frac{1}{2\pi} \frac{p}{3E} (m\mathfrak{F} - p^2\mathfrak{G})^2, \\ (f_{12}^1)_R &= \frac{1}{2\pi} \frac{\sqrt{2}p}{3} \mathfrak{F}(m\mathfrak{F} - p^2\mathfrak{G}), \\ (f_{22}^1)_R &= \frac{1}{2\pi} \frac{2p}{3} E\mathfrak{F}^2, \end{aligned} \quad (7.13)$$

which indeed satisfy the identity (7.12). We also obtain:

$$\begin{aligned} (f_S)_R &= \frac{1}{2\pi} \frac{p}{qE} (2E\mathfrak{F} + m\mathfrak{F} - p^2\mathfrak{G})^2, \\ (f_{SD})_R &= \frac{1}{2\pi} \frac{\sqrt{2}p}{qE} (E\mathfrak{F} - m\mathfrak{F} + p^2\mathfrak{G}) \\ &\quad \times (2E\mathfrak{F} + m\mathfrak{F} - p^2\mathfrak{G}), \\ (f_D)_R &= \frac{1}{2\pi} \frac{2p}{E} (E\mathfrak{F} - m\mathfrak{F} + p^2\mathfrak{G})^2. \end{aligned} \quad (7.14)$$

We shall now discuss the question of threshold conditions and the determination of the S -wave scattering lengths. An inspection of (4.33) shows that the following conditions must be satisfied in order that the G 's

be finite at $E^2=0$, and $p^2=0$:

$$f_1 - f_3 - zf_4 = O(E^2), \quad (7.15a)$$

$$f_4 + f_5 = O(p^2), \quad (7.15b)$$

$$f_3 = O(p^2), \quad (7.15c)$$

$$f_2 + zf_5 = O(p^2). \quad (7.15d)$$

The last three are threshold conditions that simply say that f_1^1, f_{SD}, f_D , etc., vanish at $\nu=0$. The general statement of the threshold conditions, which is implicit in the Mandelstam representation is that f_0^J and f_1^J behave like p^{2J} around $p^2=0$ and $f_{J-1}^J, f_{J-1, J+1}^J, f_{J+1}^J$ behave like $p^{2(J-1)}, p^{2J}, p^{2(J+1)}$, respectively. The exact solutions of the dispersion equations will automatically satisfy these conditions. We make use of them to determine the values of $f^J(0)$ in our equations. In general, however, our solutions will not satisfy the threshold conditions for high angular momenta, because of the approximations we have been forced to make; our choice of the source functions $\alpha(\nu)$ leads to violation of unitarity on the negative cut, or rather for the crossed processes and as a consequence the threshold conditions will also be violated. One can correct for this by suitably modifying the source functions at high energies (where we know nothing about them) so as to insure the proper threshold behavior of the solutions.

The determination of the S -wave scattering lengths makes use of (7.15a). Let us write it as a condition on partial waves. First we have:

$$f_3 + zf_4 = -\frac{E}{p} \sum \left(\frac{J}{J+1} P_{J+1}' - \frac{J+1}{J} P_{J-1}' \right) f_{22}^J + \frac{2J+1}{J(J+1)} P_J' f_1^J \quad (7.16)$$

$$= -\frac{E}{p} \sum \left(\frac{J-1}{J} f_{22}^{J-1} - \frac{J+2}{J+1} f_{22}^{J+1} + \frac{2J+1}{J(J+1)} f_1^J \right) P_J',$$

$$f_1 = -\frac{E}{p} \sum (2J+1) f_0^J P_J = -\frac{E}{p} \sum (f_0^{J-1} - f_0^{J+1}) P_J', \quad (7.17)$$

so that at $E^2=0$ the following relations hold:

$$f_0^{J-1} - f_0^{J+1} - \frac{J-1}{J} f_{22}^{J-1} + \frac{J+2}{J+1} f_{22}^{J+1} - \frac{2J+1}{J(J+1)} f_1^J = 0. \quad (7.18)$$

We might mention that, since at $E^2=0$ the amplitudes are complex, this relation holds for both the real and

the imaginary part of the amplitudes. Therefore they impose some restrictions on the source functions $\alpha(\nu)$ which must be chosen (in our approximate calculation) so as to comply with them. For $J=1$ and $J=2$ we obtain:

$$f_0^0 - f_0^2 + \frac{3}{2} f_{22}^2 - \frac{3}{2} f_1^1 = 0, \quad (7.19a)$$

$$f_0^1 - f_0^3 - \frac{1}{2} f_{22}^1 + \frac{4}{3} f_{22}^3 - (5/4) f_1^2 = 0. \quad (7.19b)$$

These equations determine the singlet (7.19a) and the triplet (7.19b) scattering lengths. For $J>2$, (7.18) should be automatically satisfied by the exact solutions.

Although, as we have seen, the scattering lengths can in principle be determined, in practice the method involves serious obstacles. In the first place the knowledge of a number of other partial waves would be required. In addition, in establishing the equations for the partial waves, we aimed at approximations which are presumably valid in the physical region near $E^2=m^2$. Singularities near $E^2=0$ were altogether left out. Therefore the solutions we obtain will not be accurate near $E^2=0$ and cannot be used to determine the scattering lengths. More generally we expect that, short-range forces (corresponding to multiparticle exchange terms) contribute appreciably to the scattering lengths. In view of the uncertainties connected with the determination of the scattering lengths, there is little hope of obtaining the deuteron binding energy. Since we cannot, at present, take all the above mentioned effects into account, we may be forced in practice to supply the values of both scattering lengths from experiment. On the other hand, we expect to obtain the deuteron residues with reasonable accuracy, hence be able to determine the d - to s -state ratio and the triplet effective range.

Of course, the energy dependence of the phase shifts can also be studied. We would expect to get reasonable agreement with experiment provided the one and two pion exchange effects (aside from the possibility of having to give the scattering lengths) were the dominant terms. This in turn might be the case for energies such that the momentum transfer does not exceed 3μ . It is hard to specify the energy very closely since, of course, the process $N + \bar{N} \rightarrow 3\pi$ (which is the first neglected one) does not reach full strength instantly. As a rough criterion, therefore, we might select a maximum momentum transfer of 4μ , which corresponds to a laboratory energy of about 170 Mev. It would certainly be interesting to see even with only the two pion exchange taken into account whether there was any indication of a hard core as shown by a sign change in the ${}^1S_0(I=1)$ phase shift. It is quite likely that no such effect will be found and that our inability to adequately account for the left-hand cut will necessitate the introduction of even more parameters than the zero energy scattering lengths. These might appear either as cutoffs or as parameters in phenomenologically introduced poles.

ACKNOWLEDGMENTS

Part of this work was carried out during the Summer of 1959 when two of us (M.L.G. and M.T.G.) were visiting the Radiation Laboratory, University of California and the hospitality of that Laboratory is gratefully acknowledged. It is a pleasure to thank Professor G. F. Chew, Dr. S. Mandelstam, and Dr. H. P. Noyes for many helpful conversations.

APPENDIX A. PARTIAL WAVE DISPERSION RELATIONS FOR NUCLEON-ANTINUCLEON SCATTERING

A treatment of the partial wave dispersion relations for nucleon-antinucleon scattering can be given along lines quite similar to those for the nucleon-nucleon problem. There are some important qualitative differences between the two cases which are worth bringing out.

One question that arises immediately is whether or not, in this discussion, the deuteron should be regarded as an elementary particle in so far as the nucleon-antinucleon process is concerned. One point of view which is perhaps defensible is the following: the deuteron state has nucleon number two, and is thus foreign to the nucleon-antinucleon system in much the same way as the pion, with nucleon number zero, is foreign to the nucleon-nucleon system. Thus, in the approach where one regards the pion as the source of interaction between the nucleons and the deuteron bound state as a consequence of this interaction, we would be led to consider the deuteron as the source of the nucleon-antinucleon interaction, and the pions as a consequence. Just as we imagine increasing the pion-nucleon coupling constant until the deuteron appears, we might increase the residue of the deuteron pole until the pions appear. This whole question is a rather deep one in our opinion and we hope to return to it in the future. For the purpose of the present discussion we shall assume that both the pion and the deuteron are

to be treated as actually present in the theory, with given masses.

The Mandelstam representation for the amplitudes $\bar{G}_j(s, \bar{t}, t)$ which describe nucleon-antinucleon scattering is given by an equation of the same form as (3.4) which we repeat here for convenience:

$$\begin{aligned} \bar{G}_j(s, \bar{t}, t) = & \int_{4\mu^2}^{\infty} \frac{ds'}{\pi} \int_{4m^2}^{\infty} \frac{dt'}{\pi} \frac{\bar{\rho}_{12}^j(s', \bar{t}')}{(s'-s)(\bar{t}'-\bar{t})} \\ & + \int_{4\mu^2}^{\infty} \frac{ds'}{\pi} \int_{4\mu^2}^{\infty} \frac{dt'}{\pi} \frac{\bar{\rho}_{13}^j(s', t')}{(s'-s)(t'-t)} \\ & + \int_{4m^2}^{\infty} \frac{dt'}{\pi} \int_{4\mu^2}^{\infty} \frac{ds'}{\pi} \frac{\bar{\rho}_{23}^j(\bar{t}', t')}{(\bar{t}'-\bar{t})(t'-t)} \\ & + \bar{B}_j(s, \bar{t}, t), \quad (\text{A.1}) \end{aligned}$$

where $\bar{B}_j(s, \bar{t}, t)$ contains both the one-pion and the deuteron terms. The one pion contribution is given by

$$\begin{aligned} \bar{G}_1^0 = \bar{G}_2^0 = -\bar{G}_3^0 = -\bar{G}_4^0 = \bar{G}_5^0 \\ = -\frac{3g^2}{24\pi\mu^2-t}, \\ (1 \text{ pion}) \quad \bar{G}_1^1 = -\frac{1g^2}{24\pi\mu^2-t} + 4\frac{g^2}{4\pi\mu^2-s} \quad (\text{A.2}) \\ \bar{G}_2^1 = -\bar{G}_3^1 = -\bar{G}_4^1 = \bar{G}_5^1 = -\frac{1g^2}{24\pi\mu^2-t}. \end{aligned}$$

Note in particular the pole term proportional to $(\mu^2-s)^{-1}$ which, since it appears only in \bar{G}_1^1 , leads ultimately to a pole in the 1S_0 isotopic triplet amplitude of the nucleon-antinucleon system [see Eqs. (4.23a) and (4.25a)]. The deuteron term contributes the following:

$$\begin{aligned} \bar{G}_1^1 = -\bar{G}_1^0 &= (1/32\pi m)[8m\mathfrak{F}^2 + \frac{1}{2}(s-t)m\mathcal{G}^2 + 2\mathfrak{F}\mathcal{G}(\bar{t}-t+6m^2)]/(m_D^2-\bar{t}), \\ \bar{G}_2^1 = -\bar{G}_2^0 &= (1/32\pi m)[\frac{1}{2}(t-s)m\mathcal{G}^2 + 2\mathfrak{F}\mathcal{G}(2m^2-s)]/(m_D^2-\bar{t}), \\ (\text{deuteron}) \quad \bar{G}_3^1 = -\bar{G}_3^0 &= (1/32\pi m)[-4m\mathfrak{F}^2 + \frac{1}{2}(s-t)m\mathcal{G}^2 - 4m^2\mathfrak{F}\mathcal{G}]/(m_D^2-\bar{t}), \\ \bar{G}_4^1 = -\bar{G}_4^0 &= (1/32\pi m)[-4m\mathfrak{F}^2 - \frac{1}{2}(s-t)m\mathcal{G}^2 - 4m^2\mathfrak{F}\mathcal{G}]/(m_D^2-\bar{t}), \\ \bar{G}_5^1 = -\bar{G}_5^0 &= (1/32\pi m)[-8m\mathfrak{F}^2 + \frac{1}{2}(s-t)m\mathcal{G}^2 + 2\mathfrak{F}\mathcal{G}(\bar{t}-t-2m^2)]/(m_D^2-\bar{t}). \end{aligned} \quad (\text{A.3})$$

The partial wave amplitudes can be projected out as in Sec. V. The algebraic relation between the \bar{f} 's and the \bar{G} 's is exactly the same as that between the f 's and the G 's, and we write, by analogy with (5.1),

$$h_a^J = \sum_{i,j,J'} C_{ia}^{JJ'} \int_{-1}^1 dz a_{ij}(s,z) \bar{G}_j(s, \bar{t}, t) P_{J'}(z). \quad (\text{A.4})$$

The one-pion terms lead to a pole at $s=\mu^2$ and a cut which extends from $-\infty$ to $4m^2(1-\mu^2/4m^2)$. The deuteron contributes terms of the form $(m_D^2-\bar{t})^{-1}$ which give rise to a cut in the s plane extending from $-\infty$ to $4m^2(1-m_D^2/4m^2)$. Turning now to the double integrals, the vanishing of $s'-s$ generates a cut from $4\mu^2$ to ∞

and the discontinuity across it is

$$\begin{aligned}
 & \text{Im}[h_{\alpha}^J(s) - h_{\alpha B}^J(s)] \\
 &= \sum_{i,i',J'} C_{i\alpha}^{J'J} \int_{-1}^1 dz a_{ij}(s,z) \\
 & \quad \times \left[\int_{4\mu^2}^{\infty} \frac{d\bar{t}'}{\pi} \frac{\bar{\rho}_{12}^i(s,\bar{t}')}{\bar{t}' - \bar{t}} + \int_{-2}^{\infty} \frac{d\bar{t}'}{\pi} \frac{\bar{\rho}_{13}^i(s,\bar{t}')}{\bar{t}' - \bar{t}} \right] P_{J'}(z) \\
 &= \sum_{i,i',J'} C_{i\alpha}^{J'J} \int_{-1}^1 dz a_{ij}(s,z) \bar{A}_j(s,t) P_{J'}(z), \\
 & \quad (4\mu^2 < s < \infty), \quad (\text{A.5})
 \end{aligned}$$

where $\bar{h}_{\alpha B}^J$ is the projection of the "Born" terms. The second line follows from (3.9), and of course we would be able to use the unitarity relations for the region $4\mu^2 < s < \infty$ where the process is physical.

As in the nucleon-nucleon problem, the vanishing of the other denominators is more difficult to handle. From $\bar{t}' - \bar{t} = 0$ we find a cut in the region $-\infty < s < 0$ provided that, for fixed $s = 4(p^2 + m^2)z$ is in the range $(-1 - 2m^2/p^2) < z < 1$. We obtain then a contribution

$$\begin{aligned}
 & \text{Im}[h_{\alpha}^J(s) - h_{\alpha B}^J(s)] \\
 &= - \sum_{i,i',J'} C_{i\alpha}^{J'J} \int_{(-1-2m^2/p^2)}^1 dz a_{ij}(s,z) \\
 & \quad \times \left[\int_{4\mu^2}^{\infty} \frac{ds'}{\pi} \frac{\bar{\rho}_{12}^i(s',\bar{t})}{s' - s} + P \int_{4\mu^2}^{\infty} \frac{d\bar{t}'}{\pi} \frac{\bar{\rho}_{23}^i(\bar{t},\bar{t}')}{\bar{t}' - \bar{t}} \right] P_{J'}(z) \\
 &= - \sum_{i,i',J'} C_{i\alpha}^{J'J} \int_{(-1-2m^2/p^2)}^1 dz a_{ij}(s,z) (\Delta B)_{jk} \\
 & \quad \times \text{Re} \bar{A}_k(\bar{t},t) P_{J'}(z), \quad (-\infty < s < 0), \quad (\text{A.6})
 \end{aligned}$$

where the second line follows from Eq. (3.6) [remember that the equivalent of the matrix Ω is ΔB Eq. (4.27)]. Finally, we have a contribution arising from the vanishing of $\bar{t}' - \bar{t}$. This leads to a cut from $-\infty$ to $4m^2 \times (1 - \mu^2/m^2)$ provided that for fixed s , $-1 < z < 1 + 2\mu^2/p^2$. We find

$$\begin{aligned}
 & \text{Im}[\bar{h}_{\alpha}^J(s) - h_{\alpha B}^J(s)] \\
 &= - \sum_{i,i',J'} C_{i\alpha}^{J'J} \int_{-1}^{1+2\mu^2/p^2} dz a_{ij}(s,z) \\
 & \quad \times \left[\int_{4\mu^2}^{\infty} \frac{ds'}{\pi} \frac{\bar{\rho}_{12}^i(s',t)}{s' - s} + P \int_{4\mu^2}^{\infty} \frac{d\bar{t}'}{\pi} \frac{\bar{\rho}_{23}^i(\bar{t}',t)}{\bar{t}' - \bar{t}} \right] P_{J'}(z) \\
 &= - \sum_{i,i',J'} C_{i\alpha}^{J'J} \int_{-1}^{1+2\mu^2/p^2} dz a_{ij}(s,z) (\Delta BK \Delta B)_{jk} \\
 & \quad \times \text{Re} \bar{A}_k(t,s) P_{J'}(z) \quad (-\infty < s < 4m^2(1 - \mu^2/m^2)), \\
 & \quad (\text{A.7})
 \end{aligned}$$

where we have used Eqs. (3.6) and (3.12) to get the second line. The contribution just obtained corresponds to "crossed" nucleon-antinucleon scattering in which t plays the role of energy and s that of momentum transfer between the nucleons.

We see that the analytic structure of the nucleon-antinucleon partial wave amplitudes is considerably more complicated than that met in the nucleon-nucleon problem. Let us write $\text{Im} \bar{h}_{\alpha 1}^J$ for the contribution given by (A.5) in the region $4\mu^2 < s < 0$, $\text{Im} \bar{h}_{\alpha 2}^J$ for (A.6) in the region $-\infty < s < 0$ and finally $\text{Im} \bar{h}_{\alpha 3}^J$ for the contribution (A.7) in $-\infty < s < 4m^2(1 - \mu^2/m^2)$. A representation for $\bar{h}_{\alpha}^J(s)$ which expresses all of this information may be written as follows (we omit discussion of behavior at infinity):

$$\begin{aligned}
 h_{\alpha}^J(s) &= h_{\alpha B}^J(s) + \int_{4\mu^2}^{\infty} \frac{ds'}{\pi} \frac{\text{Im} h_{\alpha 1}^J(s')}{s' - s} \\
 & \quad + \int_{-\infty}^0 \frac{ds'}{\pi} \frac{\text{Im} h_{\alpha 2}^J(s')}{s' - s} \\
 & \quad + \int_{-\infty}^{4m^2(1-\mu^2/m^2)} \frac{ds'}{\pi} \frac{\text{Im} h_{\alpha 3}^J(s')}{s' - s}. \quad (\text{A.8})
 \end{aligned}$$

It should be noted that the cuts associated with $\text{Im} \bar{h}_{\alpha 1}^J$ and $\text{Im} \bar{h}_{\alpha 3}^J$ overlap and further, that they both involve the nucleon-antinucleon amplitude in the unphysical region. We shall see that the absorptive amplitudes $\bar{A}(\bar{t},t)$ and $\bar{A}(t,s)$ that enter in this overlap region are in fact both real and can be expanded in a Legendre series. The presence of $\text{Im} \bar{h}_{\alpha 3}^J$ means that there is an explicit coupling of partial wave amplitudes, in contrast with the nucleon-nucleon case. Also, as mentioned in Sec. VI, the multipion states occur in the vicinity of the physical threshold, so that no approximation which neglects them makes much sense. The only possible approach for handling the situation would have to be a phenomenological one.

In order to analyze the problem of the expansion of the absorptive amplitudes in partial waves, it is convenient to make a series of variable changes analogous to those made in Sec. V. In evaluating the integral over $\text{Im} \bar{h}_{\alpha 2}^J$ we have to consider the following type of quantity:

$$\begin{aligned}
 I_2 &= - \int_{-\infty}^0 \frac{ds'}{s' - s} \int_{(-1-2m^2/p^2)}^1 dz a(s',z) \\
 & \quad \times A[-2p'^2(1+z), -2p'^2(1-z)] P_{J'}(z), \quad (\text{A.9})
 \end{aligned}$$

where we have dropped irrelevant factors. We introduce $s'' = -2p'^2(1+z)$ and find

$$\begin{aligned}
 I_2 &= \int_{-\infty}^0 \frac{ds'}{s' - s} \int_{4m^2}^{-4p'^2} \frac{ds''}{2p'^2} a(s',z) \\
 & \quad \times A[s'', -2p'^2(1-z)] P_{J'}(z), \quad (\text{A.10})
 \end{aligned}$$

$$\mathcal{R}(\bar{\nu}) = \int_{\nu_0}^{\infty} D(-\nu)^T \alpha(-\nu) D(-\nu) \frac{d\nu}{(\nu+\bar{\nu})^2} - \int_{\nu_0}^{\infty} \frac{d\nu'}{\nu'+\bar{\nu}} \int_{\nu_0}^{\infty} \frac{d\nu}{\nu+\bar{\nu}} D(-\nu)^T \alpha(-\nu) K(\nu, \nu') \times \alpha(-\nu') D(-\nu'), \quad (\text{C.7})$$

$$\eta(\bar{\nu}) = h(\bar{\nu})^{-1} - \gamma(-\bar{\nu}). \quad (\text{C.8})$$

Now it can be shown, because of the symmetric nature of $K(\nu, \nu')$, that, when $D(-\nu)$ satisfies the integral equation (C.3) the expression $\mathcal{E}^T \mathcal{R}^{-1} \mathcal{E}$ is stationary. But when $D(-\nu)$ is a solution of the integral equation, (C.5) gives:

$$\mathcal{E}^T \mathcal{R}^{-1} \mathcal{E} = \mathcal{E}^T(\bar{\nu}) N(\bar{\nu})^{-1}, \quad (\text{C.9})$$

and making use of (C.1) and (C.3) one deduces:

$$\mathcal{E}^T N^{-1} = -d\eta/d\bar{\nu}. \quad (\text{C.10})$$

The variational principle gives then:

$$-d\eta/d\bar{\nu} = (\eta L_1 + L_2) \mathcal{R}^{-1} (L_1^T \eta + L_2^T), \quad (\text{C.11})$$

which can be used to calculate successive derivatives of η . For the lowest angular momentum the variational principle for the first derivative at $\bar{\nu}=0$ gives the effective range in terms of the scattering length. It seems, therefore appropriate to make a power series expansion of $\eta(\bar{\nu})$:

$$\eta(\bar{\nu}) = (1/m)(a^{-1} + \frac{1}{2}r\nu + \dots). \quad (\text{C.12})$$

The coefficient r in the relativistic expansion is related to the nonrelativistic effective range by:

$$r = r_e + 4/\pi m - a^{-1}/m^2. \quad (\text{C.13})$$

The double integral in (C.7) is positive definite. Therefore if $-\alpha(-\nu)$ is positive definite, (C.9) is actually a minimum (and negative) and the value obtained for r is positive and a lower bound.

For higher angular momenta one can take advantage of the vanishing of the amplitudes at threshold, $h(0)=0$, to derive a more powerful variational principle for the

amplitudes themselves. We now make a subtraction in (7.6) at $\nu = -\bar{\nu}$:

$$D(-\nu) = D(\bar{\nu}) - (\nu + \bar{\nu}) \times \int_{\nu_0}^{\infty} \alpha(-\nu') D(-\nu') K(\nu', \nu, -\bar{\nu}) \frac{d\nu'}{\nu'}, \quad (\text{C.14})$$

where

$$K(\nu', \nu, -\bar{\nu}) = \frac{1}{\pi} \int_0^{\infty} \left(\frac{\nu''}{\nu'' + m^2} \right)^{\frac{1}{2}} \frac{d\nu''}{(\nu'' + \nu')(\nu'' + \nu)(\nu'' - \bar{\nu})}. \quad (\text{C.15})$$

Multiplying (C.14) by $D(-\nu)^T \alpha(-\nu)/(\nu + \bar{\nu})\nu$ and integrating one obtains:

$$\int_{\nu_0}^{\infty} D(-\nu)^T \alpha(-\nu) D(\bar{\nu}) \frac{d\nu}{\nu(\nu + \bar{\nu})} = \int_{\nu_0}^{\infty} D(-\nu)^T \alpha(-\nu) D(-\nu) \frac{d\nu}{\nu(\nu + \bar{\nu})} \int_{\nu_0}^{\infty} \frac{d\nu}{\nu} \int_{\nu_0}^{\infty} \frac{d\nu'}{\nu'} \times D(-\nu)^T \alpha(-\nu) K(\nu, \nu', -\bar{\nu}) \alpha(-\nu') D(-\nu'), \quad (\text{C.16})$$

or in an obvious notation:

$$\mathcal{L}_1(\bar{\nu}) D(\bar{\nu}) = \mathcal{R}_1(\bar{\nu}). \quad (\text{C.17})$$

Again the kernel $K(\nu, \nu', -\bar{\nu})$ is symmetric and one obtains that $\mathcal{L}_1^{-1} \mathcal{R}_1 (\mathcal{L}_1^{-1})^T$ is stationary when $D(-\nu)$ satisfies the integral equation (C.14). But then (C.17) holds and gives:

$$\mathcal{L}_1^{-1} \mathcal{R}_1 (\mathcal{L}_1^{-1})^T = D(\bar{\nu}) (\mathcal{L}_1^{-1})^T. \quad (\text{C.18})$$

On the other hand from (7.4) one can readily identify $\mathcal{L}_1^T(\bar{\nu})$ as $N(\bar{\nu})$, and the variational principle is established for the inverse of the amplitude:

$$h(\bar{\nu})^{-1} = \mathcal{L}_1^{-1} \mathcal{R}_1 (\mathcal{L}_1^{-1})^T. \quad (\text{C.19})$$

For $\bar{\nu} > 0$ (physical region) both sides of this equation become complex but the imaginary parts are identical. The variational principle obtains therefore for the real part.