

Lawrence Berkeley National Laboratory

Lawrence Berkeley National Laboratory

Title

A laser-based longitudinal density monitor for the large hadron collider

Permalink

<https://escholarship.org/uc/item/9c56v3j1>

Authors

Beche, J.-F.

Byrd, J.

Datte, P.

et al.

Publication Date

2004-07-01

A LASER-BASED LONGITUDINAL DENSITY MONITOR FOR THE LARGE HADRON COLLIDER*

J.-F. Beche, J. Byrd, P. Datte[#], S. De Santis, M. Placidi, V. Riot[#], R. Schoenlein, W. Turner, M. Zolotorev, LBNL, Berkeley, CA 94720, USA

Abstract

We report on the development of an instrument for the measurement of the longitudinal beam profile in the Large Hadron Collider (LHC). The technique used, which has been successfully demonstrated at the Advanced Light Source, mixes the synchrotron radiation with the light from a mode-locked solid state laser oscillator in a non-linear crystal. The up-converted radiation is then detected with a photomultiplier and processed to extract, store and display the required information.

A 40 MHz laser, phase-locked to the ring radiofrequency system, with a 50 ps pulse length, would be suitable for measuring the dynamics of the core of each of the LHC 2808 bunches in a time span much shorter than the synchrotron period. The same instrument could also monitor the evolution of the bunch tails, the presence of untrapped particles and their diffusion into nominally empty RF buckets (“ghost bunches”) as required by the CERN specifications.

instrument mixes on a non-linear crystal the synchrotron light emitted by the LHC beams with a short laser pulse. The up-converted radiation is detected on a photomultiplier and then stored in digital format. By choosing a laser pulse duration much shorter than the beam’s it is possible to sample a narrow time-slice of each bunch. The laser repetition frequency is selected in such way as to allow for the maximum number of bunches to be sampled each turn. We will illustrate in another section how the choice of a particular repetition frequency is related to the various beam parameters one wants to measure with this instrument. Essentially, our technique is analogous to that of a sampling scope, in this case working at optical frequencies, as the shape of each bunch is reconstructed by taking individual samples in succeeding turns. Though we will refer to the LHC throughout this paper, our technique is suitable to be used on almost any synchrotron ring, with the exception of those where the synchrotron light emitted doesn’t have a high enough flux for the particular application required.

INTRODUCTION

The basic concept for a longitudinal density monitor to be installed in the LHC has been presented in [1]. Our

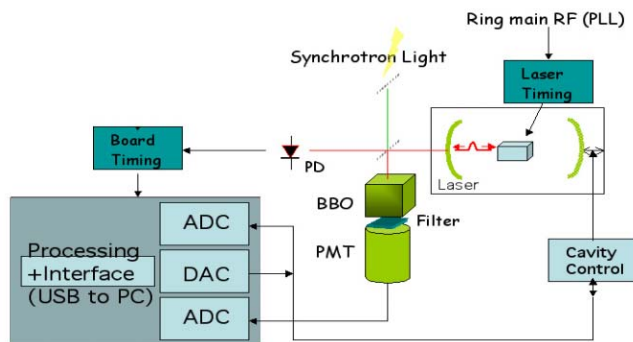

Figure 1. Schematic of the laser-mixing technique for longitudinal beam density.

Figure 1 shows the functional units composing our instrument. The laser is locked to the ring’s main radiofrequency and a photodiode is used to detect the laser firing and trigger the data acquisition board. The board also generates a slow modulation of the laser cavity length in

such way as to sweep the laser pulse over the entire bunch length. This modulation signal is stored together with the photomultiplier data so that each beam sample is associated to the particular position along the bunch it comes from. A longitudinal density monitor prototype,

* Work supported by the U.S. Department of Energy under Contract No. DE-AC03-76SF00098.

[#] Presently at Lawrence Livermore National Laboratory.

based on the scheme in Fig.1, was successfully tested at the Advanced Light Source; experimental results were reported in [2].

LHC SPECIFICATION FOR LONGITUDINAL BEAM MONITORING

The requirements for measuring the longitudinal distribution of the LHC beams are reported in [3]. Machine protection, background in the experiments and accelerator physics application define three areas for accuracy, sensitivity and dynamic range.

MODE		SENSITIVITY		
		Ultra-high	High	Standard
Observation period (ns)		100	0.05	0.05
Integration time (s / rev)		0.1 / 1100	10 / 10 ⁵	10 ⁻³ / 10
UPD (p/ps)	0.45TeV 7TeV		0.9x10 ⁸ 2x10 ⁸	
Sensitivity (p/ps)	0.45TeV 7TeV	≤4x10 ⁴ ≤60	10 ⁴	10 ⁶
Sensitivity/UPD	0.45TeV 7TeV	4.4x10 ⁻⁴ 3x10 ⁻⁷	5x10 ⁻⁵	5x10 ⁻³
Dynamic range (p/ps)	0.45TeV 7TeV	4x10 ⁵ 6x10 ⁴	10 ⁴ -3x10 ⁸	10 ⁶ -5x10 ⁸
Accuracy (p/ps)	0.45TeV 7TeV	±2x10 ³ ±30	±4x10 ³	±10 ⁴
Transmission rate (s)		≤1	60	0.1

Table 1. Specifications for the measurement of the beam longitudinal profile in the LHC.

The specifications reported in the “Ultra-high Sensitivity” column in Tab.1 derive from machine protection requirements and involve measuring very low charge densities (as low as 60 protons per picosecond) over the 3.3 μs duration of the LHC abort gap. The “High Sensitivity” requirements originate from the need for monitoring bunch tails, the fraction of unbunched beam and the diffusion of charges from the filled RF buckets into the nominally empty ones, which cause background in the experiments and radiation flashes during the energy ramp. This application is characterized by the number of data points taken around the machine (the ~89 μs long circumference subdivided in 50 ps slices) and high dynamic range, up to 4 order of magnitude. Finally, the “Standard Sensitivity” specifications have been defined for monitoring the bunch core (bunch length, phase and longitudinal distribution) with a 50 ps resolution, in a time short compared to the 40 ms synchrotron period and for all the 2808 LHC bunches.

The very diverse specifications listed above make the problem of trying to satisfy all of them with a single instrument a challenging one. In the following section we evaluate the design parameters for a device based on the laser-mixing technique.

FUNCTIONAL PARAMETERS FOR A LONGITUDINAL DENSITY MONITOR

Based on our experience with the prototype of the longitudinal density monitor tested at the ALS, we can try to extrapolate what its parameters should be for being utilized on the LHC.

Firstly, only every tenth bunch is filled in the LHC. This means that the bunch repetition frequency is 40 MHz, which we therefore select as our laser pulse repetition rate. This is a rather ordinary value, while a repetition rate of 400 MHz, synchronous with the RF buckets frequency, is not ordinarily achievable.

As a second step, we see from Tab.1 that the finest resolution required is 50 ps. Therefore, a laser pulse length of 50 ps would be sufficient. Laser systems with a pulse lengths much shorter than that are commercially available. The difficulty lays in that the efficiency of the up-conversion process is directly proportional to the laser power density [4]. As an example, in the ALS we used a 50 fs pulse length on a 100 mW Ti:Al₂O₃ laser oscillator; to maintain the efficiency constant, all other things being equal, would require a 100 W system when using 50 ps pulses. On the other hand, using a shorter pulse length, thus easing the requirement on the laser average power, would not be feasible, as it would entail taking more data points. Because of the laser pulse repetition rate limitations, this in turn would mean increasing the time necessary for a measurement proportionally to the decrease in laser power. We think that a 10 W laser, which is not beyond today’s state-of-the-art, could be adequate. Using a Nd:YAG laser at 1064 nm would allow to tune the system (i.e. optimizing the non-linear crystal length and angle cut) to have its up-conversion efficiency peak around 900 nm for a resulting wavelength of 490 nm, where photodetectors exhibit the best quantum efficiency.

A synchrotron light port for longitudinal and transverse diagnostics has been designed for the LHC. It is composed of two movable extraction mirrors and a 5T

superconducting undulator and a separator dipole magnet, which are the prevailing light sources at low and high energy respectively [5].

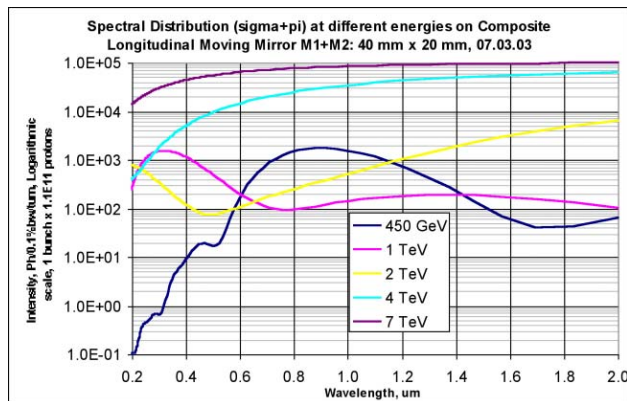

Figure 2. Calculated LHC photon flux (M. Facchini).

From the calculated photon flux (Fig.2), we can estimate the number of photons counts detected by our instrument. This number is a first step towards assessing if the required accuracy is achievable in the allowed integration time for the various applications.

First of all, the product of the up-conversion efficiency and the bandwidth is a constant [6]. If we take into account the photodetector quantum efficiency, we obtain for a 10 W, 40 MHz CW laser, operating at 1064 nm with a 50 ps pulse length (and estimating a typical quantum efficiency at 900 nm):

$$\eta_{tot} = \eta_{mix} \frac{d\omega}{\omega} QE = 3 \cdot 10^{-3} \times 0.3 \approx 1 \cdot 10^{-3} \quad (1)$$

From Eq.(1) and Fig.2 the number of photon counts detected at 900 nm per proton and per turn is approximately $1.6 \cdot 10^{-8}$ at 450 GeV and $7.4 \cdot 10^{-7}$ at 7 TeV.

Ultra-high Sensitivity

The 3.3 μ s abort gap can be sampled once every 500 turns and there are four 50 ps samples taken each turn in every 100 ns time slice (the required resolution). At 450 GeV the specified $4 \cdot 10^4$ p/ps accumulates 60 photon counts per each 100 ns period every 500 turns. At 7 GeV this number is reduced to about 4, which still allows to detect the presence of charges above the threshold. 500 turns take ~ 45 ms which is a factor of two below the maximum 100 ns integration time. The required modulation frequency of the laser cavity for scanning the beam is ~ 10 Hz, which is the same frequency used in the ALS experiment and presents no problem.

High Sensitivity

Scanning the entire LHC ring once requires 500 turns. A 10 s integration time allows for accumulating more than 220 measurements of the same 50 ps sample. Again, laser cavity modulation presents no challenge. For this application, the minimum charge density specified in Tab.1 yields 80 photon counts at 7 TeV and around 2 at

450 GeV. Monitoring in the High Sensitivity mode is mainly required at collision energy, so that for this application the actual challenge is in the PMT linearity over four orders of magnitude, rather than in the low number of detected photons. Single-photon counting mode would be perhaps best suited in this case.

Standard Sensitivity

For this application the bunch core at $\pm 2\sigma$ is subdivided in 22 consecutive 50 ps samples. Each filled bunch is sampled once every turn; therefore, sampling once the entire core of all the LHC bunches requires 22 turns (i.e. ~ 2 ms). Sampling twice each slice still keeps the integration time below one tenth of the synchrotron period and eases the requirement for the laser cavity modulation down to 125 Hz. The lower bound 10^6 population from Tab.1 yields about 70 counts at 7 TeV, but less than 2 at 450 GeV. The 1% accuracy required is therefore not achievable all over the bunch core if one wants to resolve synchrotron motion at the same time.

CONCLUSIONS

We give an overview of an optical sampling technique, based on non-linear laser mixing, for measuring the longitudinal beam density in the LHC. Based on our experience with a prototype of such a system at the ALS, we believe that it would be possible to apply a similar device to the measurement of beam longitudinal profiles in the LHC, substantially satisfying the design specifications. We also define the basic parameters for the laser system and estimate the instrument performance.

REFERENCES

- [1] M. Zolotarev, J.-F. Beche, et al., "Development of a Longitudinal Density Monitor for Storage Rings", PAC'03, Portland, May 2003.
- [2] J.-F. Beche, J. Byrd, et al., "Measurement of the Beam Longitudinal Profile in a Storage Ring by Non-Linear Laser Mixing", BIW 2004, Knoxville, 2004.
- [3] C. Fischer, "High Sensitivity Measurement of the Longitudinal distribution of the LHC Beams", LHC-B-ES-0005, 2003.
- [4] M. Zolotarev, J.-F. Beche, et al., "Longitudinal Beam Density in a Storage Ring", in preparation.
- [5] M. Facchini and R. Jung, "Longitudinal Diagnostics Mirror Configuration for the LHC Beam", AB-BI Note, April 3, 2003.
- [6] M. Placidi, W. Turner, et al., "Notes on the Measurement of Longitudinal Beam Density in LHC Using Optical Methods", CBP Tech Note 307, 2003.