

Lawrence Berkeley National Laboratory

Recent Work

Title

ac LOSS MEASUREMENTS IN SUPERCONDUCTING MAGNETS

Permalink

<https://escholarship.org/uc/item/98x751fk>

Authors

Gilbert, William S.

Hintz, Roland E.

Voelker, Ferd.

Publication Date

1968-04-01

aj.2

University of California Ernest O. Lawrence Radiation Laboratory

TWO-WEEK LOAN COPY

*This is a Library Circulating Copy
which may be borrowed for two weeks.
For a personal retention copy, call
Tech. Info. Division, Ext. 5545*

ac LOSS MEASUREMENTS IN SUPERCONDUCTING MAGNETS

William S. Gilbert, Roland E. Hintz, and Ferd Voelker

April 1968

RECEIVED
LAWRENCE
RADIATION LABORATORY

MAY 21 1968

Berkeley, California

LIBRARY AND
DOCUMENTS SECTION

UCRL-18176
aj.2

DISCLAIMER

This document was prepared as an account of work sponsored by the United States Government. While this document is believed to contain correct information, neither the United States Government nor any agency thereof, nor the Regents of the University of California, nor any of their employees, makes any warranty, express or implied, or assumes any legal responsibility for the accuracy, completeness, or usefulness of any information, apparatus, product, or process disclosed, or represents that its use would not infringe privately owned rights. Reference herein to any specific commercial product, process, or service by its trade name, trademark, manufacturer, or otherwise, does not necessarily constitute or imply its endorsement, recommendation, or favoring by the United States Government or any agency thereof, or the Regents of the University of California. The views and opinions of authors expressed herein do not necessarily state or reflect those of the United States Government or any agency thereof or the Regents of the University of California.

UCRL-18176 Errata
UC-34 Physics
TID-4500 (51st Ed.)

UNIVERSITY OF CALIFORNIA
Lawrence Radiation Laboratory
Berkeley, California

AEC Contract No. W-7405-eng-48

May 8, 1968

ERRATA

TO: All recipients of UCRL-18176
FROM: Technical Information Division
SUBJECT: UCRL-18176, "ac Loss Measurements in Superconducting Magnets," William S. Gilbert, Ronald E. Hintz, and Ferd Voelker, April 1968.

Please correct subject report as follows:

On the cover, title page, page 1, and page 23, reference 8,

Mr. Hintz's first name is Ronald, not Roland.

UCRL-18176
UC-34 Physics
TID-4500 (5 1st Ed.)

UNIVERSITY OF CALIFORNIA

Lawrence Radiation Laboratory
Berkeley, California

AEC Contract No. W-7405-eng-48

ac LOSS MEASUREMENTS IN SUPERCONDUCTING MAGNETS

William S. Gilbert, Roland E. Hintz, and Ferd Voelker

April 1968

Printed in the United States of America
Available from
Clearinghouse for Federal Scientific and Technical Information
National Bureau of Standards, U. S. Department of Commerce
Springfield, Virginia 22151
Price: Printed Copy \$3.00; Microfiche \$0.65

ac LOSS MEASUREMENTS IN SUPERCONDUCTING MAGNETS

William S. Gilbert, Roland E. Hintz, and Ferd Voelker

Lawrence Radiation Laboratory
University of California
Berkeley, California

April 1968

ABSTRACT

Measurements have been made of energy lost in charging and discharging superconducting magnets containing NbTi material. An electrical multiplier technique has been developed for measuring these losses. Single-cycle losses can be determined with this method. Loss data have been obtained for peak magnetic fields ranging from a few kilogauss to 70 kilogauss. These measured losses are compared with theory. A new "ordering effect," in which the cyclic loss depends on the previous magnetic history of the superconductor, has been found.

INTRODUCTION

Superconducting magnets appear to have a promising future in high energy physics because of their ability to produce magnetic fields higher than is possible for conventional iron magnets, and with a markedly reduced electrical power requirement in the dc, or steady-state, mode. The heat that is generated must be removed at liquid helium temperature, and the cost of providing this refrigeration is one of the major cost items in a superconducting magnet system.

The rate at which the field is changed can vary from as low as once a month for a large bubble chamber magnet or a transport magnet in a constant-momentum beam line, through 20% changes every hour in transport elements in experimental beam lines, to 100% field changes every few seconds in switching magnets or magnets for a superconducting synchrotron. The dc losses are caused by heat leaks into the magnet system rather than by heat generation in the superconductor itself. The ac losses are produced in the superconductor itself, and eddy-current losses occur in the normal conductors present. These ac losses are dependent on the physical properties of the superconducting and other magnet materials, and an understanding of this dependence is required in order to determine the heat generated in superconducting magnets under an assumed set of operating conditions.

Several calculations of ac losses have been made and a few measurements have been performed.¹⁻⁴ Smith has made measurements with small solenoids, using NbZr wire and Nb₃Sn tape, with peak fields ranging from 1.5 to 10 kG, and he finds satisfactory agreement with theory.⁵ Sampson tested a racetrack dipole wound with Nb₃Sn tape, with a maximum field of 16 kG in the aperture.⁴ He measured losses up to 5 watts, but the complicated geometry made it difficult to compare losses with theory.

Our measurements were made with three solenoid coils wound with NbTi wire. The smallest coil is capable of a maximum field of 70 kG and the wire is electrically insulated, so we could pulse this magnet to the limit imposed by heat transfer considerations. The larger coils are of similar construction.

EXPERIMENTAL DESCRIPTION

Magnet A

The magnet is a solenoid wound with Supercon NbTi wire (T48B) with a 0.015-in. -diameter superconducting core in a copper wire of 0.030 in. overall diameter. The wire is electrically insulated by oxidizing the copper surface, the oxide providing turn-to-turn insulation. Layer-to-layer insulation is provided by fiberglass cloth. Details are included in Hintz's report, and this particular coil is designated T-2 in Table I of that report.⁶ Its specifications are:

- winding, i. d. = 1.5 in., o. d. = 4.5 in., length = 4.5 in. ;
- inductance = 1.3 henry;
- maximum field on axis = 70 kG at $I = 120$ A;
- average current density = $20\,000$ A/cm²;
- stainless steel flanges and winding spool.

A photograph of this magnet appears as Fig. 1.

Experimental Arrangement and Procedure

A schematic representation of the ac loss generation and measurement experiment is shown in Fig. 2. The different components are briefly noted below, and some are expanded upon in the appendix.

Function generator--power supply

We cycled the magnet through a given current waveform for individual run times ranging from tens of seconds to an hour. We could adjust the frequency, the maximum current, and the minimum current, and the waveshape could be sine wave, triangular wave, or square wave. Most data were taken with the triangular waveshape, for which the ac losses were the same as for sine wave excitation.

Dewar--helium boiloff measurement

A single fiberglass epoxy Dewar was used, 8-in. in diameter by some 4 ft high; the upper portion was filled with Styrofoam to minimize the heat losses. The background heat leak, with no magnet excitation, was approximately 1 watt as determined by the positive displacement gas-flow meter. A rotary potentiometer was attached to the meter's mechanical readout shaft, so the information was available to us in an electrical form. When heat was being produced in the magnet by ac losses, the helium boiloff did not stabilize for up to 40 minutes.

Measurement--Hall multiplier

The power lost in the magnet was measured with the apparatus described in the appendix. Reliable data were obtained in the range of 0.1 to 10 watts.



CBB 682-749

Fig. 1. Magnet A.

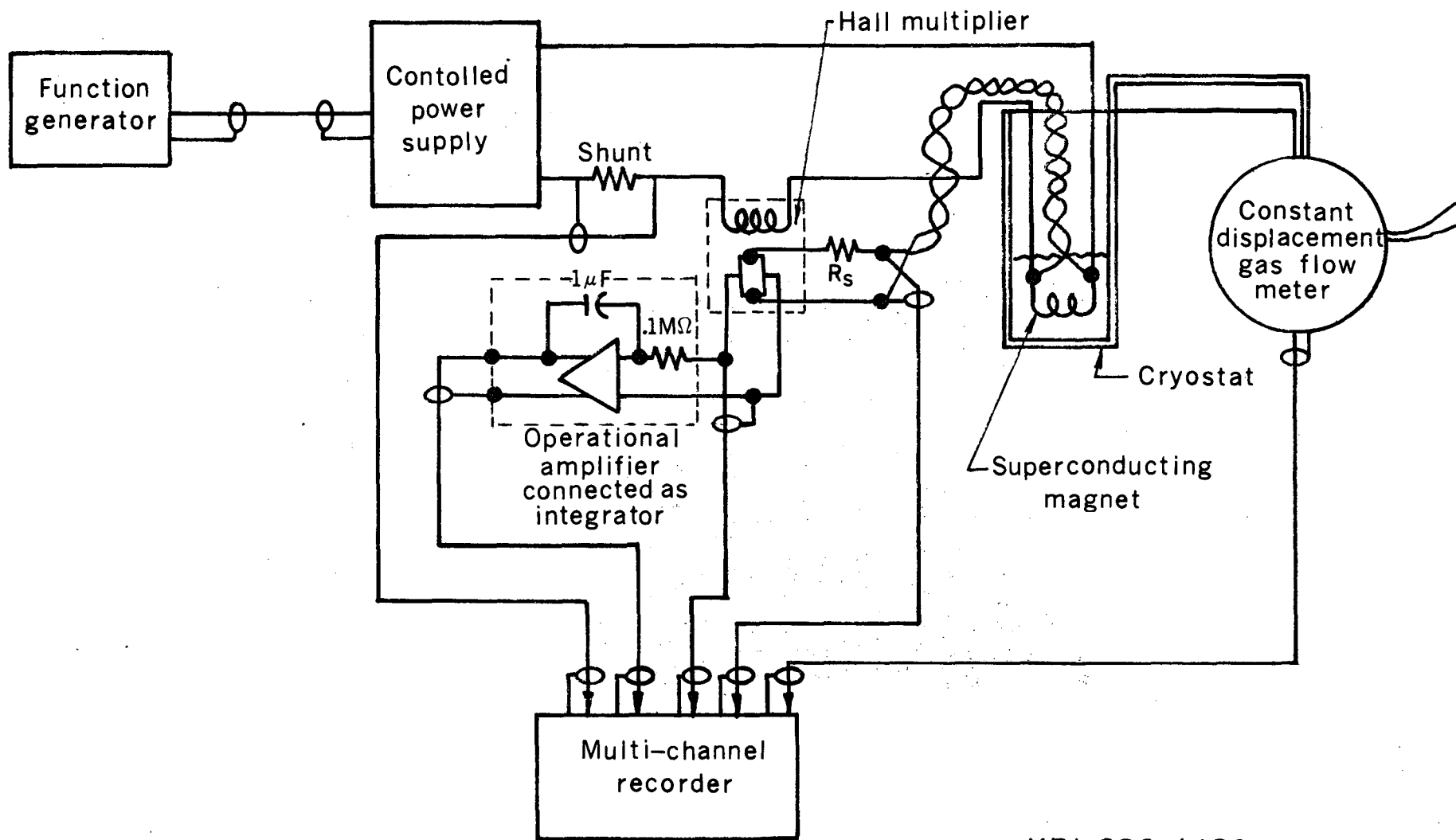

XBL 682 4489

Fig. 2. Schematic representation of pulsed loss experiments.

The lower limit was set by system sensitivity, primarily drift. The upper limit was set by the heat-transfer characteristics of our magnet; above 10 watts average power, magnet A went normal.

EXPERIMENTAL DATA--MAGNET A

Energy Loss/Cycle vs Cycle Frequency

The ac losses in superconducting material should depend only on the maximum and minimum magnetic fields experienced in traversing a given cycle, and not on the path or frequency.¹⁻³ Thus, for given end points, the loss should be a constant energy per cycle, or the power should be a linear function of frequency. Eddy current heating in a normal conductor, however, depends on H^2 , so the eddy current contribution will not add a constant energy term per cycle.

In Fig. 3 are shown the data on loss/cycle vs cycle frequency for several maximum excitation currents. At the lowest frequency end, the accuracy of the data is determined by the drift rate of the electronic integrating circuit. The above difficulty is not intrinsic to the measurement method and has been rectified. At the higher frequencies, the power losses in the coil heat the superconducting wires and thereby change the loss per cycle. Eddy effects, if any, also contribute to the nonconstancy of the loss/cycle with frequency. Since one of our objectives is to determine the losses at the highest possible magnetic field, we desire to test at the lowest frequency so as not to heat and thereby transition the coil. Most of the data were taken at 0.1 Hz.

Energy Loss/Cycle vs Maximum Excitation Current

Figure 4 displays the loss vs I_{\max} data from $I_{\max} = 20$ A to $I_{\max} = 120$ A. Data from different experimental setups, different Hall multipliers, different voltage sources, and different helium temperatures are included. All the data are reasonably consistent. Error analysis of the data is not possible, since we continuously changed the experimental setups. Uncertainties imposed by instrumentation sensitivity and resolution are usually less than 20%, but data from one setup to another differed by as much as a factor of 2. We now believe this nonreproducibility to be due to the "ordering effect" discussed on page 13.

Many measurements were made with I_{\max} less than 20 A. The maximum fields were low and the data are not included.

Miscellaneous Observations

Loss Proportional to ΔI

The loss-vs- I_{\max} function for a particular coil is shown in Fig. 4. The loss rises steeply with increasing I_{\max} , or the equivalent H_{\max} . By changing the minimum current from zero to I_{\min} , one can test whether the loss depends on I_{\max} alone or $(I_{\max} - I_{\min})$, or some other form. On Fig. 4 is shown one datum for which the $L \propto (I_{\max} - I_{\min})$ dependence gives satisfactory agreement. Several similar checks were made for the runs in which

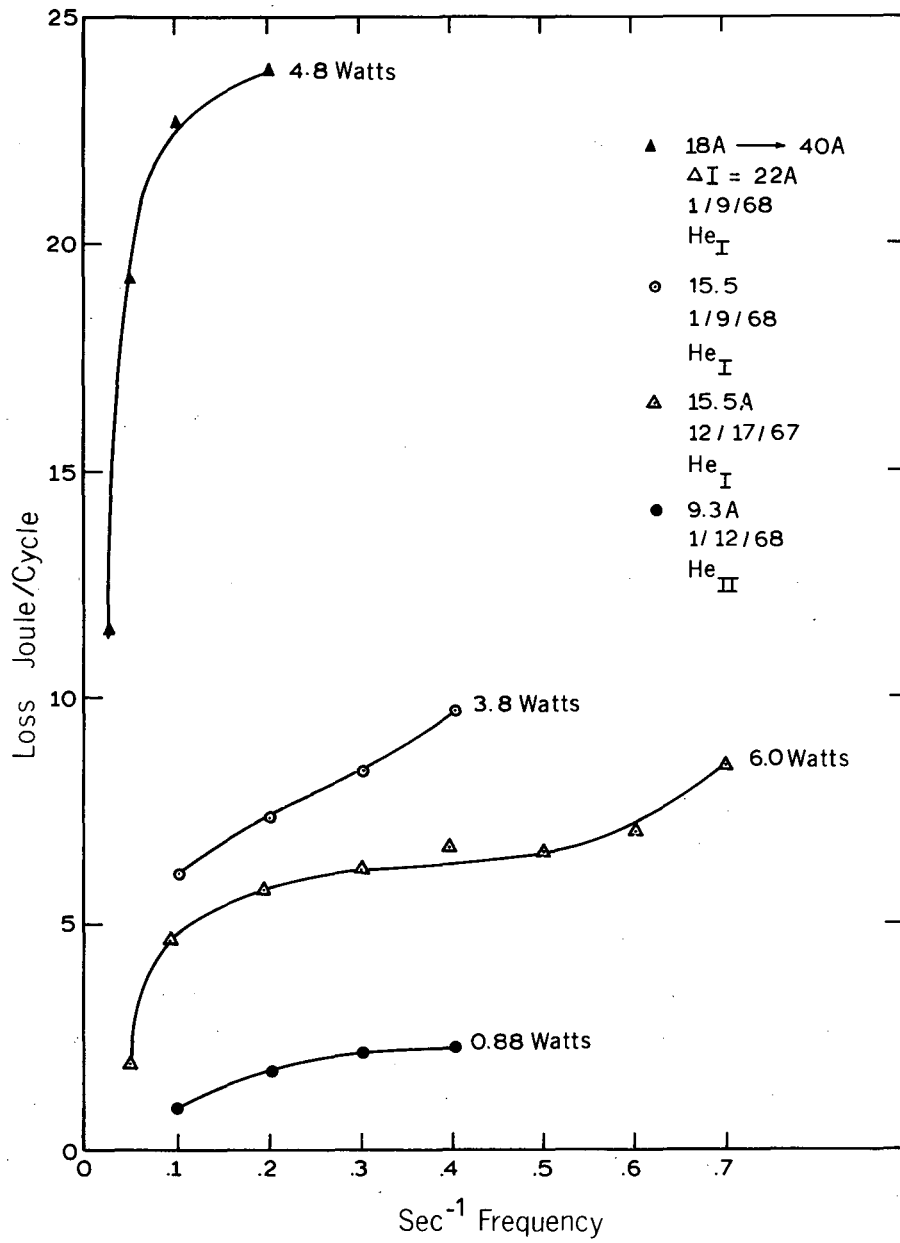

XBL 682 4488

Fig. 3. Loss per cycle vs cycle frequency for Magnet A.

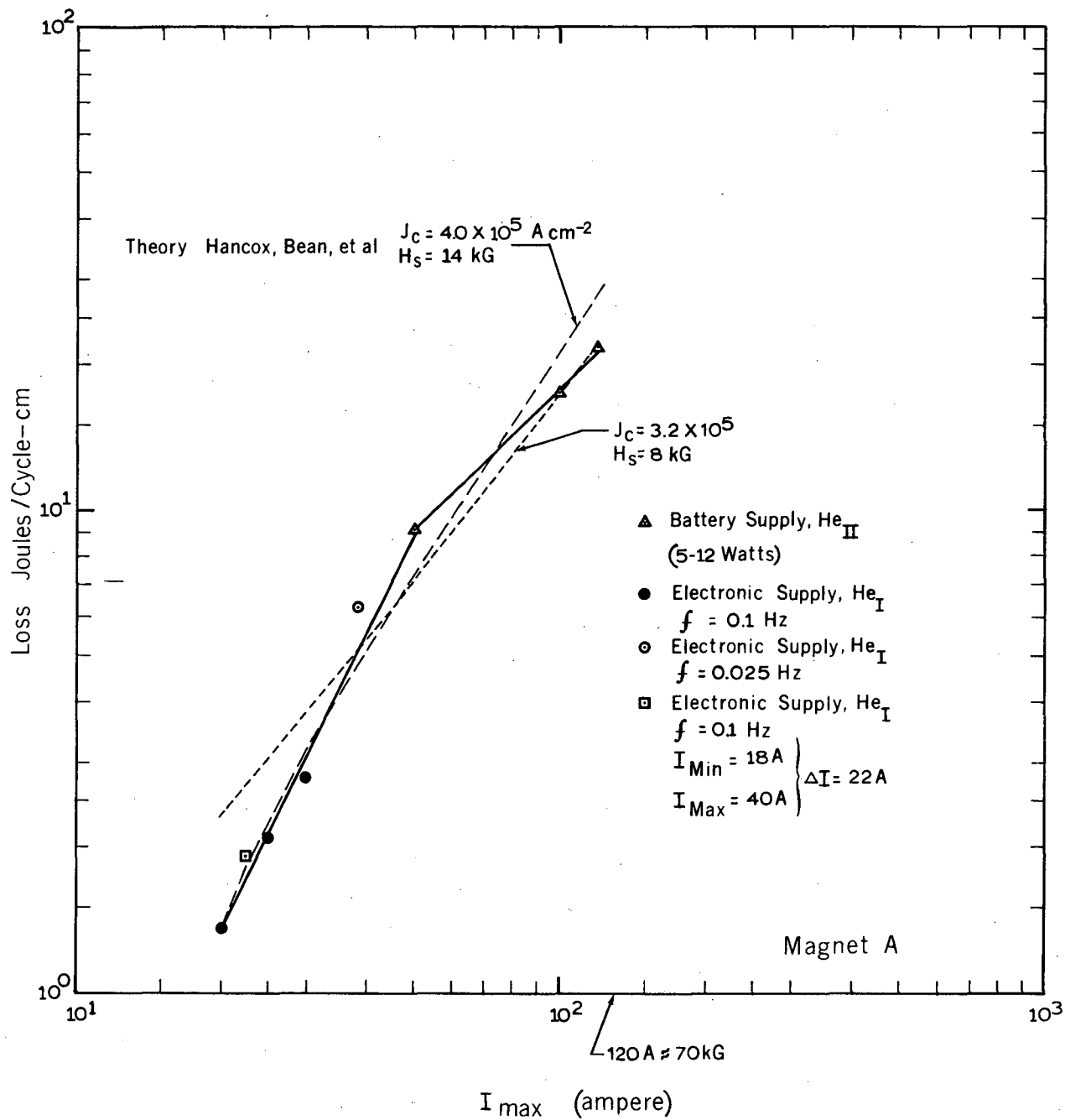

XBL 682 4487

Fig. 4. Loss per cycle vs I_{max} for Magnet A.

$I_{\max} \leq 20$ A, the data for which are not included in this report.

Temperature Dependence, He_I and He_{II}

The usual method of operation was to have our helium Dewar vented at approximately atmospheric pressure, so that the operating temperature of the helium was 4.2°K and the temperature of the coil windings were determined by the heat generated, the heat transfer, and the 4.2°K bath temperature. We observed that at an average power input of 6 W the coil went normal.

It was felt that the use of the He_{II} might result in better local heat transfer, so that losses at larger I_{\max} could be measured. The Dewar was mechanically pumped to a pressure of some 20 mm, so that the bath temperature was below 2°K. Average power inputs of 10 to 12 W did not cause the coil to go normal so long as the helium was below the λ point. For smaller power inputs the losses were approximately the same as at 4.2°K.

Current Sources: Battery, Electronic Power Supply

The electronic power supply we used had a relatively large output ripple voltage at 360 Hz. The tested coils had inductances of 1.3 H and 35 H, so that the 360-Hz current component was small compared with our slowly cycled currents. We also used storage batteries as current sources, so no ripple voltage was present. The measured losses were about the same with the storage batteries as with the electronic supply, so the ripple voltage did not influence our measurements.

COMPARISON WITH THEORY

In a solenoid coil the magnetic field varies in both the radial and axial directions, and, in this experiment, the entire field is modulated with the time variation imposed. The elementary loss formulas are derived for the magnetic field's being either far lower or much greater than the field necessary to penetrate to the center of the superconducting wire.¹⁻³ In practice a large fraction of the coil has maximum magnetic fields near this penetration field strength, for which the loss calculation is more uncertain. Rather than comment further on various theoretical models, we list formulas we have used and the losses calculated from them.

From Bean et al.,³ we use the equation (36) appearing on page 42 as derived by H. R. Hart, Jr., and P. S. Swartz. The heat generated in charging a long solenoid, per unit length, is

$$\frac{Q}{l} = 10^{-8} \cdot \frac{\pi}{12} \cdot \lambda H_0 J_c \frac{\pi}{4} d (a_2 - a_1)(a_2 + 2a_1) \text{ joules/cm, (1)}$$

where

- λ = packing factor,
- H_0 = maximum field at critical current,
- d = diameter of wire,
- a_2 = outer radius of solenoid,
- a_1 = inner radius of solenoid.

Per cycle, the magnet loss is $L = 2 \frac{Q}{I}$. (2)

J_c , the critical current density, is not well defined in that heat is generated from low fields to high fields and the J_c changes continuously in this range. One can work backwards from the measured loss and derive an average J_c . Thus, one can consider J_c to be an adjustable constant.

For a given coil, excited to a fraction F of its critical current--i. e., $F = I_{\max}/I_{\text{crit}}$ --the loss equation, (18) in Hancox,² is used:

$$W = a \mu_0 H_c^2 \frac{1+F^2/3}{2F} - 4a \mu_0 H_s^2 \frac{(1-F^3)}{3}, \quad (3)$$

where

H_s = penetration field;

at $F = 1$;

$$W = \frac{2a \mu_0 H_c^2}{3}, \quad (4)$$

which is Eq. (17) in Hancox. We define the L_{\max} , the maximum loss at

$$I_{\max} = I_{\text{crit}}, \quad (5)$$

from (2) and (4):

$$L_{\max} = 2 \frac{Q}{I} = \frac{2a \mu_0 H_c^2}{3}; \quad (6)$$

from (3) and (6):

$$L_{\text{th}} = 3/4 L_{\max} F \left(1 + \frac{F^2}{3}\right) - 2L_{\max} \left(\frac{H_s}{H_0}\right)^2 (1 - F^3). \quad (7)$$

We can attempt to fit the experimental data with a best pair of J_c and H_s values; all the other parameters are specified in the theories. Both theories are presumed to hold for very long solenoids, whereas our measured coil is only as long as the outside diameter, 4.5 in. = 11.4 cm. For the measured L_m 's, we simply divided the total coil losses by the 11.4-cm length. In Table I, below, we list the measured L_m 's at various I_{\max} , together with L_{th} for various sets of J_c and H_s .

The loss numbers listed in Table I are plotted on Fig. 4. The experimental conditions differed in two major respects from the assumptions used in the theories: the solenoid was not long, and the temperature in the windings did rise above the bath temperature. Despite these differences one can get satisfactory agreement between experiment and theory for reasonable values of J_c and H_s :

$$J_c = 3.2 - 4.0 \times 10^5 \text{ A/cm}^2,$$

$$H_s = 8 \text{ to } 14 \text{ kG.}$$

The H_s does not correspond to the average J_c derived, but is close to the value $H_s = 15 \text{ kG}$ for 0.012-in. -diameter NbTi wire, quoted by Roger Boom, of Atomic International.⁷

Table I. Measured and calculated losses for magnet A.

I_{\max} (A)	L_m (J/cm)	$J_c = 3.2 \times 10^5 \text{ A/cm}^2$ $H_s = 8 \text{ kG}$		$J_c = 4.0 \times 10^5 \text{ A/cm}^2$ $H_s = 14 \text{ kG}$	
		L_{th} (J/cm)	L_{th}/L_m	L_{th} (J/cm)	L_{th}/L_m
20	1.38	2.30	1.67	1.33	0.97
22.5	1.92	2.67	1.39	1.80	0.94
25	2.10	3.04	1.45	2.27	1.08
30	2.80	3.80	1.36	3.23	1.16
38.5	6.30	5.13	0.82	4.93	0.78
50	9.19	7.03	0.77	7.36	0.80
100	17.5	17.4	0.99	21.1	1.21
120	21.9	23.0	1.05	28.7	1.31

MAGNET B

A larger end-corrected solenoid employing the same type of wire and method of construction has been fabricated for a physics experiment to be performed at the 184-inch cyclotron. A photograph of this magnet appears as Fig. 5. A drawing of this magnet is in Fig. 6, together with pertinent magnet specifications.⁸ For the tests, the magnet was immersed vertically in a 7-ft-deep Dewar.

Pulsed loss data on this magnet were obtained up to an $I_{\max} = 100 \text{ A}$. Two different experimental setups were run on different dates. In the first series of measurements, the integrator that was used for magnet A experiments was utilized. Loss measurements were taken across the center third of the magnet, with one loss measurement made across the entire magnet. The largest I_{\max} in this series was 34 A. In the second series of measurements, a more stable integrator was used and losses were determined across the entire magnet. To compare and connect the two series of measurements we have to assume that the ratio of loss in the center section to the loss in the entire magnet is constant.

The data are displayed in Fig. 7, as are the predictions based on the theory discussed above, with the values

$$J_c = 8.0 \times 10^5 \text{ A/cm}^2,$$

$$H_s = 12 \text{ kG}.$$

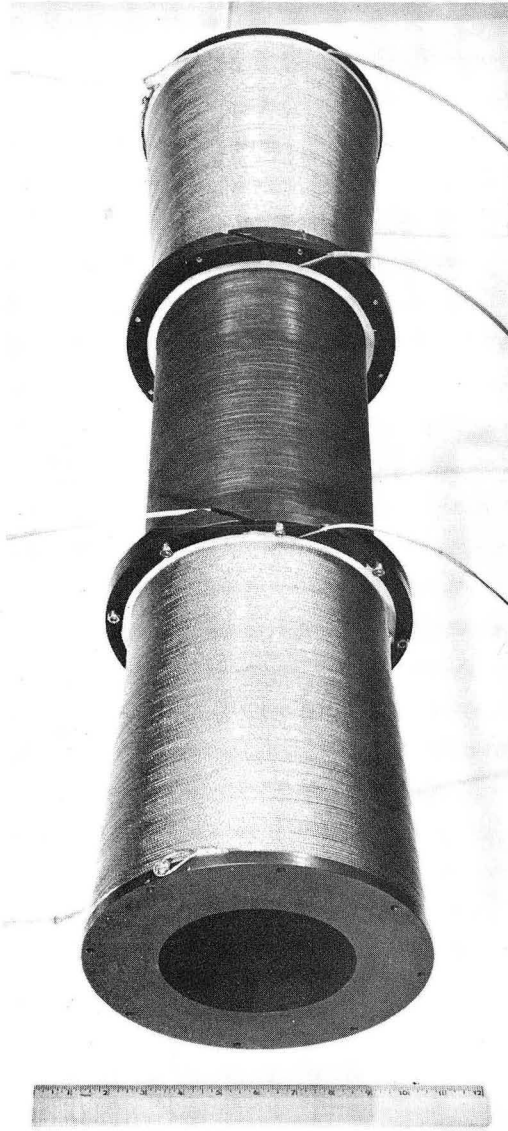

CBB 682-611

Fig. 5. Magnet B.

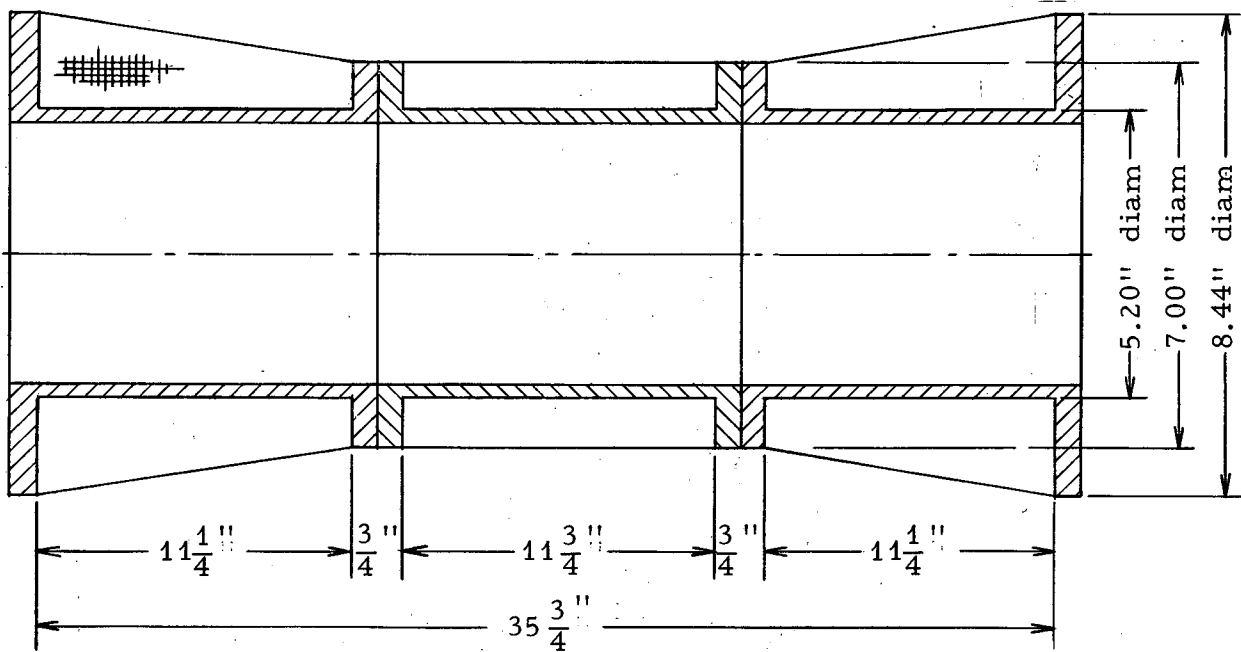

Fig. 6. Cross section of magnet shown in Fig. 5. Specifications as follows:

Conductor: wire; 0.015-in. -diam. NbTi core, 0.030-in. -diam Cu sheath.

Insulation between turns: copper oxide layer.

Insulation between layers: two layers 0.003-in. fiberglass cloth.

Cross section per turn as wound: 0.001020 in.².

Number of turns: 39 785.

	<u>Design value</u>	<u>Test maximum</u>
Current	88 A	111 A
$\int B_z dz$ (kG-ft)	140 (= 4270 kG-cm)	177
Field at center (kG)	38.3	48.6
Maximum field at conductor (kG)	51.7	65.5
Current density (kA/cm ²) based on spare inside bobbins	13 500	17 000

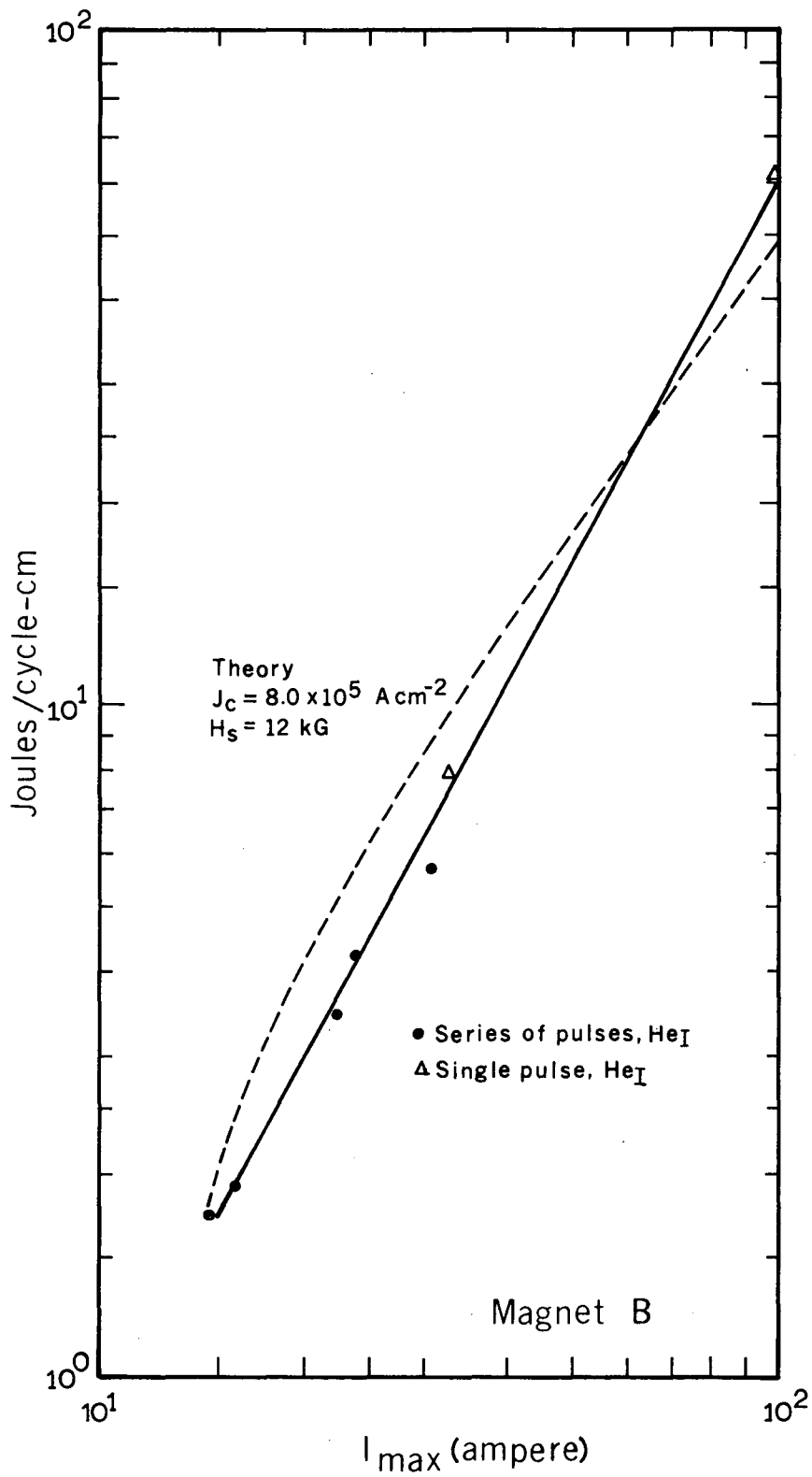

XBL 684 4827

Fig. 7. Loss per cycle vs I_{max} for Magnet B.

MAGNET C

A third solenoid we tested is shown in Fig. 8. The method of construction of this magnet is similar to that of the other two magnets, but the superconducting wire itself is significantly different. The NbTi core is 0.019 in. in diameter and the overall diameter of the copper is 0.024 in., so that the resultant coil is understabilized. We observed that this coil transitioned far below its short-sample characteristic and the transition current depended on the rate of charge, whereas the other two well stabilized magnets achieved short-sample current behavior.

The coil parameters are:

Inner radius = 6.84 cm,
 Outer radius = 7.84 cm,
 Length = 24.8 cm,
 Coil load line, 60 kG at $I_{crit} = 200$ A (short sample),
 Transition current measured 60 to 90 A.

While investigating the variability of the coil's transition current, we discovered a new "ordering" effect that sheds light on our previous data and on the general problem of heat generated in superconductors by changing magnetic fields. The energy lost in a superconducting (SC) coil in changing the current depends on its previous history and decreases markedly from the first cycle. The detailed data are discussed in the following section.

The experimental data are shown in Fig. 9. The theoretical curve is computed with $J_c = 2.0 \times 10^5$ A/cm² and $H_s = 13$ kG. Since the experimental loss at $I_{max} = 40$ A varies by a factor of 5 from the first pulse to the fourth pulse, it is difficult at this time to say much about the agreement between experiment and theory. The J_c for this magnet is much lower than those used in fitting the data from magnets A and B.

"ORDERING EFFECT"

In the loss measurements on magnet C, we used a more stable integrator and read the output with a digital voltmeter, so that we were able to measure losses on a single pulse basis. What at first seemed to be a non-reproducibility in our equipment turned out to be a nonconstancy in the energy loss per cycle in the magnet as one cycled the magnet through identical current programs. The losses became smaller, approaching an asymptote, upon repetitive cycling as if some smoothing, or ordering, were taking place. This is not the same as the training effect, in which one can transition a magnet to progressively higher transition currents. In our present case, when we carefully work up the current through many cycles and then transition, subsequent transitions occur at progressively lower transition currents.

Figure 10 displays a series of magnet cycles following a transition. Four cycles at $I_M = 40$ A are followed by five cycles at $I_M = 50$ A. In each series the asymptotic values are much lower than the first cycle, and the 50-A asymptote has a reasonable value relative to the 40-A asymptote. The 50-A first-cycle loss, however, is far larger than the 40-A asymptote, but still is smaller than the 40-A first cycle.

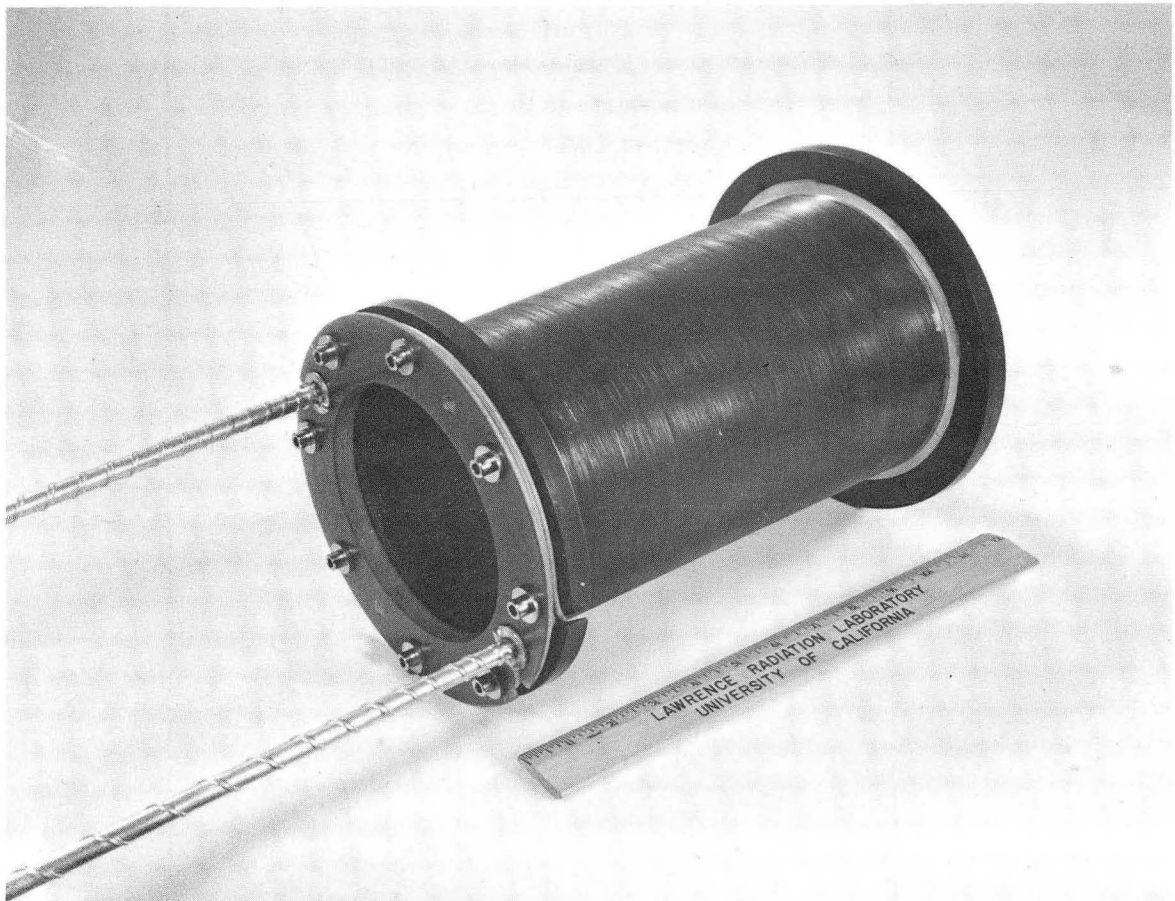

CBB 679-5638

Fig. 8. Magnet C.

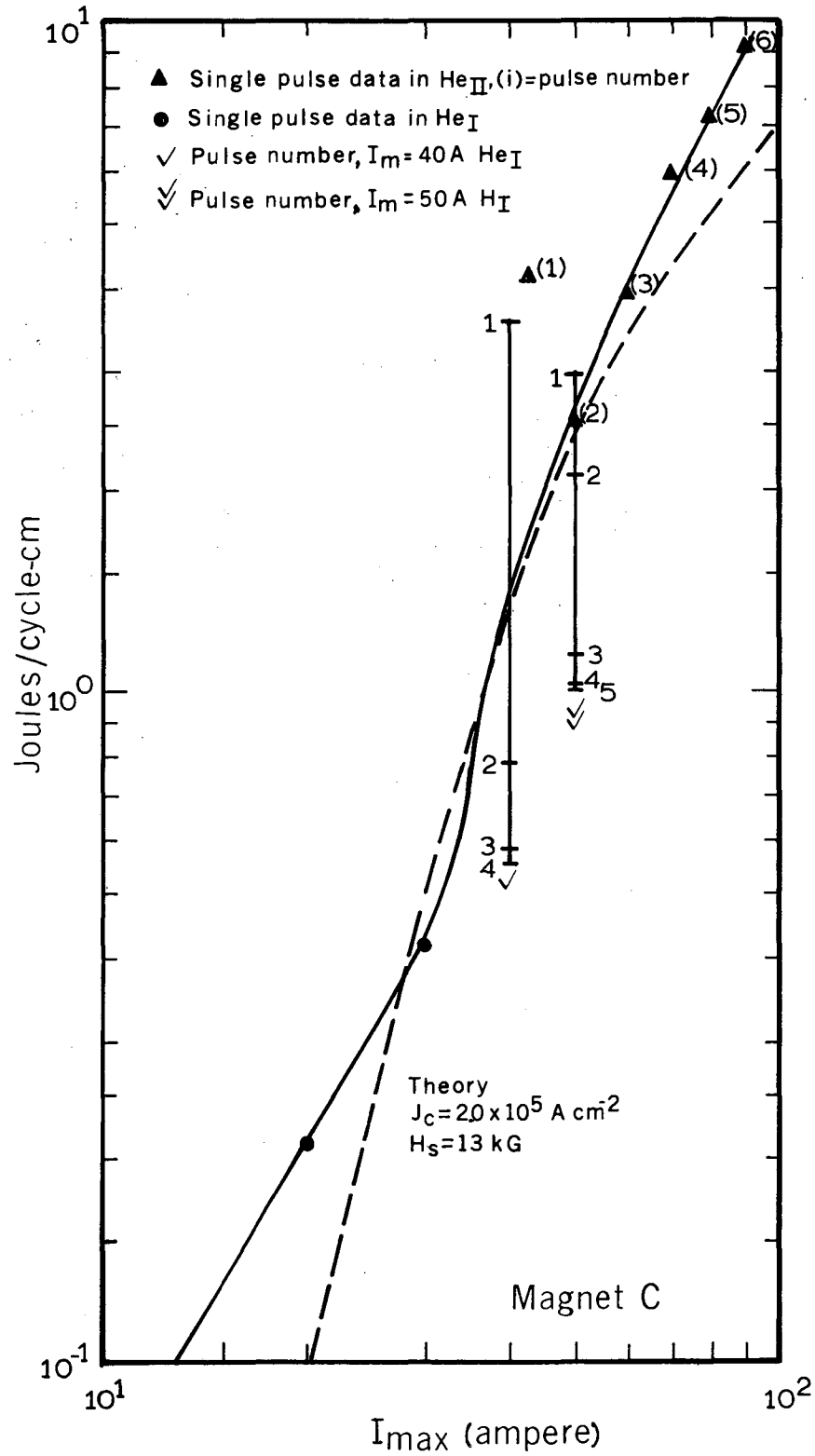

XBL684 4828

Fig. 9. Loss per cycle vs I_{max} for Magnet C.

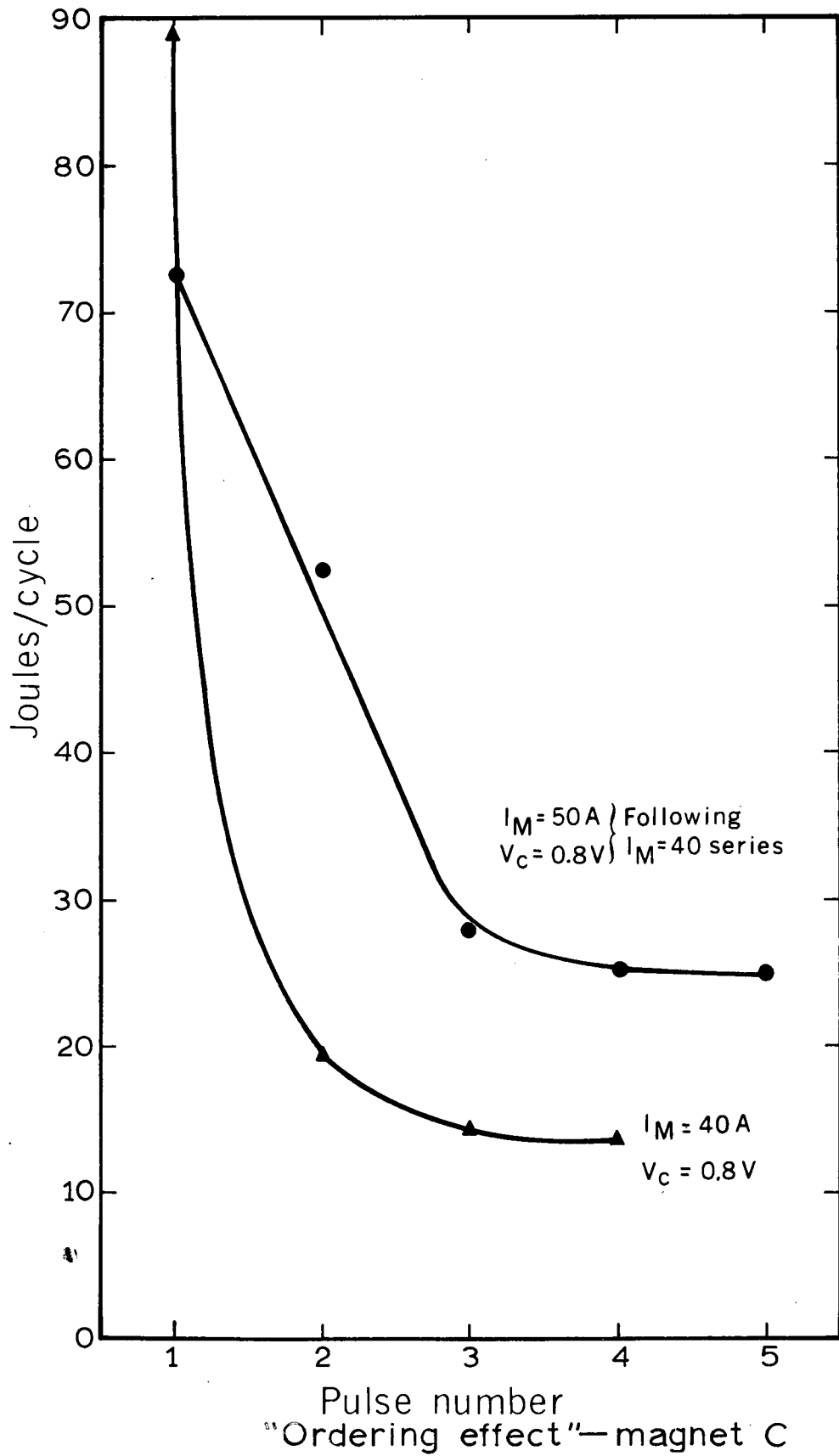

XBL 684 4829

Fig. 10. Loss per cycle vs pulse number for Magnet C.

In Fig. 11 are shown more data, together with a repeat of those of Fig. 9. First is the 40-A series, followed by the 50-A series. Charge rate dependence was then tested by doubling the driving voltage; the change was small, so the important factor seems to be the current swing that was established in the previous history. The leads were then reversed, so that current had to flow in the opposite direction, and the first-pulse loss was almost the same as that following a transition, even though no transition had taken place.

We expect that more detailed investigation of the role of this effect on the heat generation process during the charging of SC magnets will result in understabilized magnets' being brought nearer to their short-sample limits. We have observed, in a qualitative way, the correlation of flux jumps with the high first-cycle losses. Extensive work is continuing in this area, but we deemed this effect sufficiently important to include this note in this report.

ACKNOWLEDGMENTS

We are pleased to acknowledge the use of the magnets built for Melvin Klein (magnet A) and Mrs. Pam Surko (magnet B). Terry Jackson designed our versatile power supply and one of our integrators, and Earl Knight did much of the electrical assembly. We are also indebted to Ross Nemetz for his part in assembling the magnet (magnet A) in its Dewar and for the tedious job of getting it superconducting for each of the many runs. Wayne Vogen similarly operated the second test magnet. We wish to thank Dr. Denis Keefe and Dr. Edward Lofgren for their continuing interest in and support of this program.

This work was done under auspices of the U. S. Atomic Energy Commission.

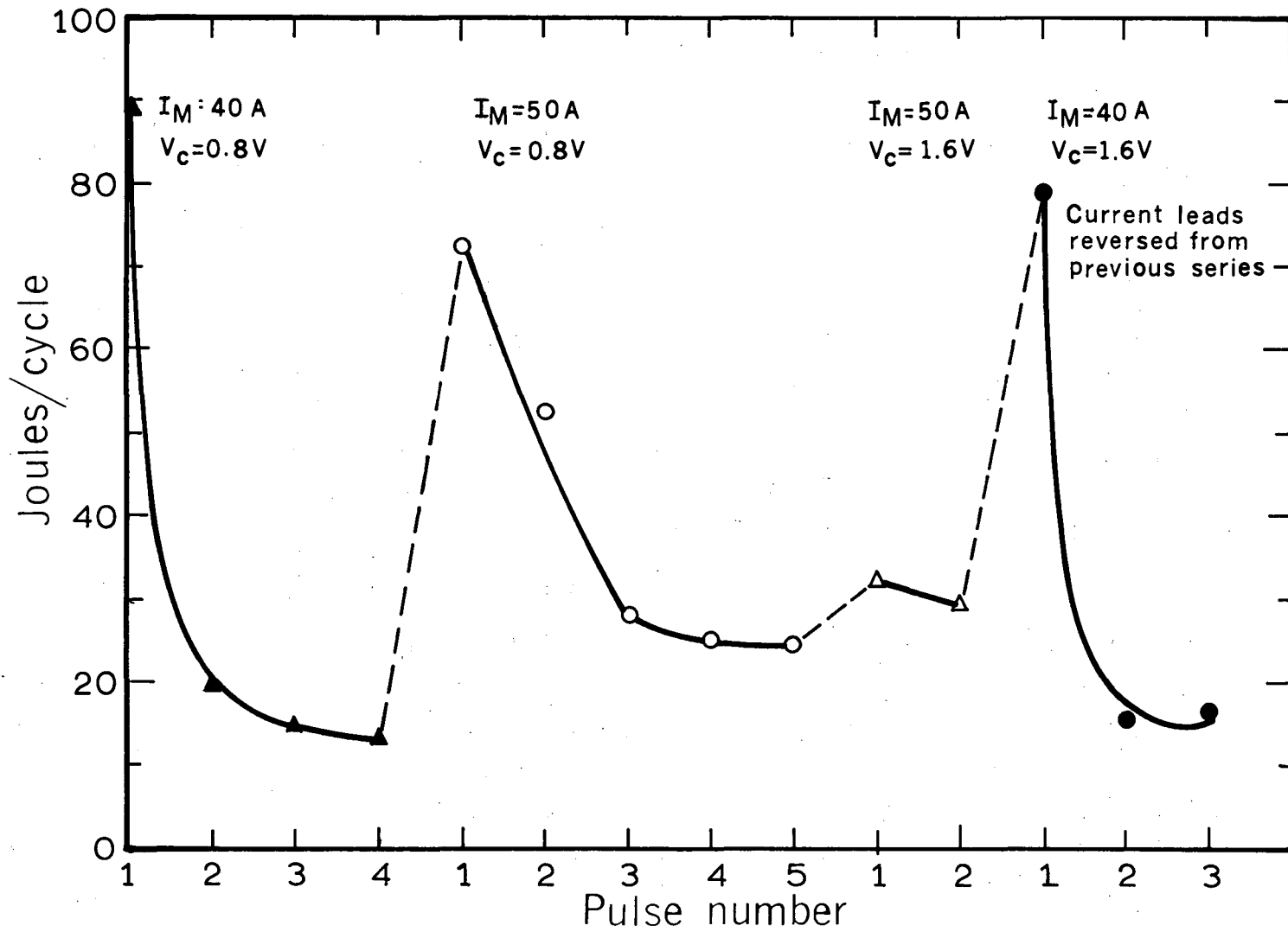

"Ordering effect"—magnet C

XBL 684 4830

Fig. 11. Loss per cycle vs pulse number for Magnet C.

APPENDIX

Loss Measurement

This is a description of an electrical method of measuring ac losses in superconducting magnets, which has worked very well for us at Lawrence Radiation Laboratory. The electronic equipment used with magnets A and B limits our measurements to losses greater than about 100 mW. The fundamental problem of measuring ac losses electrically is that reactive power into the magnet is hundreds (or thousands) of times greater than power loss due to heating. Our solution to the problem is based on the fact that the integral with respect to time of power over a complete ac cycle is the energy loss per cycle, and also that accuracy can be improved by integrating over many cycles.

The problem then reduces to building a device that monitors the electrical energy into and out of the magnet. The difference between energy supplied and returned each cycle can be displayed on a chart recorder. Figure 2 shows the schematic of a typical experimental setup. We have used a Hall device in a multiplier circuit to generate an electrical signal proportional to instantaneous power. This signal is then integrated by an operational amplifier circuit to give a voltage proportional to accumulated energy at each instant. Figure 12 is a recording typical of our data. On one channel there is a triangular waveform of current through the magnet, and on the other channel there is a display of energy being cycled in and out of the magnet. In this example the energy loss over twenty or so cycles was nearly as large as the energy stored during each cycle, and there is a pronounced drift in the energy curve. The slope of this drift is a measure of the ac power loss in the magnet. Most of our runs were made with a controllable 250-A power supply with SCR's in the secondary of the transformer. Adjusting the firing angle of the SCR's allows us to provide any voltage between -75 and +75 V (including zero) while still furnishing current. The supply is controlled by a current regulator which can reproduce a reference waveshape up to about 10 Hz cycling frequency, provided this does not require a value of $L di/dt$ greater than the power supply voltage.

The multiplier circuit works in the following way. It uses a semiconductor Hall device which develops an output voltage proportional to the product of input current to the Hall device and magnetic field surrounding the device. A pair of potential leads inserted into the cryostat connects the test magnet to the Hall device through a resistor, so that current input to the Hall device is proportional to the magnet voltage. The Hall device is mounted in the gap of a small magnet which has been designed to give a magnetic field proportional to current in its windings. This magnet is put in series with the superconducting magnet so that the Hall device has a magnetic field input proportional to the current in the SC magnet. The inputs to the Hall device, then, are proportional to voltage across the SC magnet, and to current through it, and hence the output of the Hall device is a voltage proportional to instantaneous power into the SC magnet. This output voltage changes polarity with the direction of power flow.

Although the output from the Hall device is ideally a voltage proportional to the instantaneous product of the two inputs, there is in practice a small

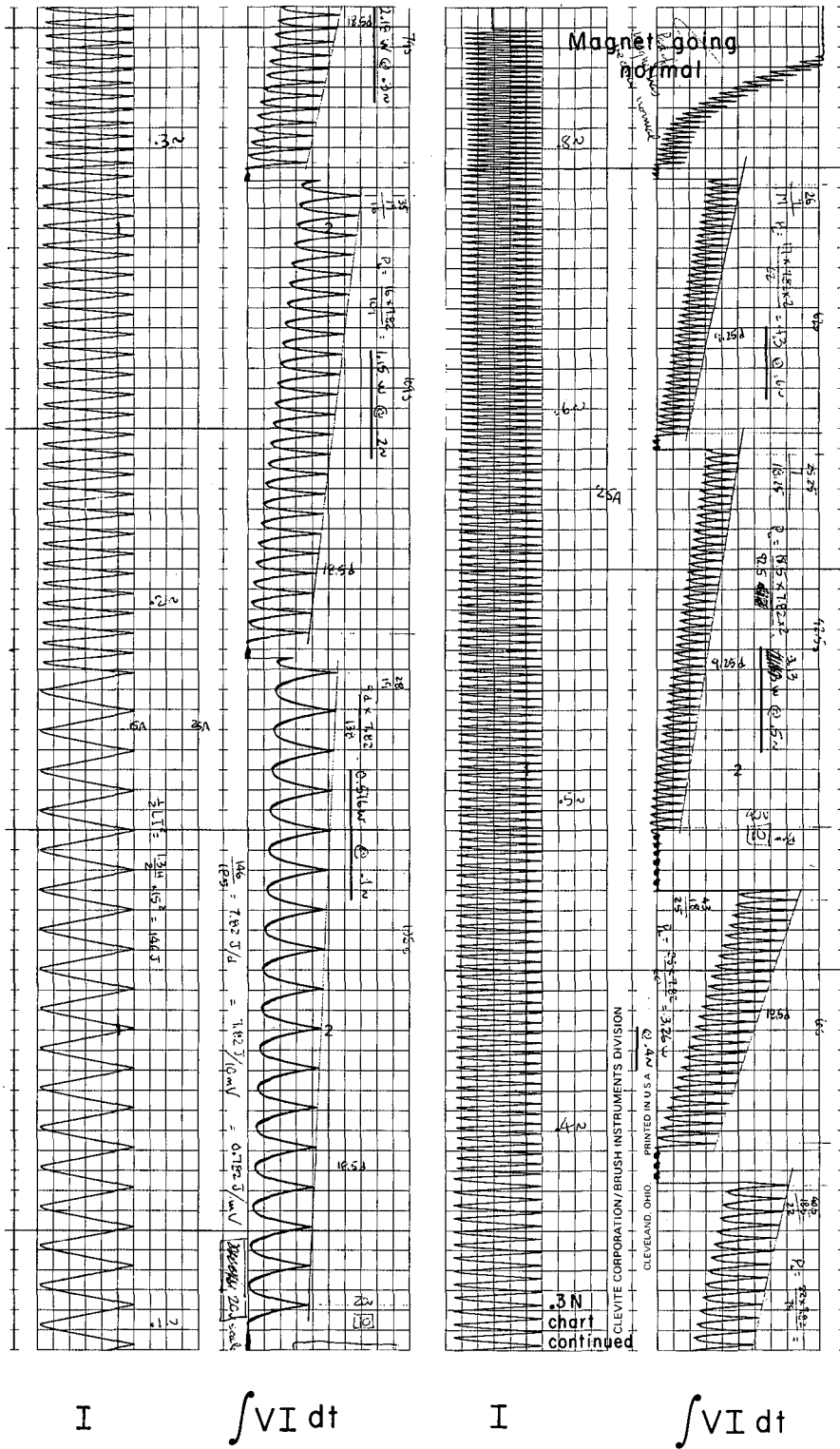

XBL684-2320

Fig. 12. Recorder traces for Magnet A: I vs t, $\int VI dt$ vs t.

error voltage proportional to input current because of imperfections in construction. This error voltage can be partially compensated for by suitable circuitry, however. Our first multiplier was constructed by our own group, but we later purchased commercial units from F. W. Bell and from Ohio Semitronics. These all provide an output voltage which is linear with input power to about 0.5% of full range, and all needed various degrees of compensation. The departure from linearity is one of our present limitations, and affects the accuracy in measuring small losses in the presence of large reactive power.

The integrator circuit for measurements on magnets A and B used an FET input solid-state operational amplifier, with a 1- μ F feedback capacitor and a 0.1-M Ω series resistor, so that the output voltage is

$$e_{\text{out}} = \frac{1}{RC} \int e_{\text{in}}(t) dt,$$

where $RC = 0.1$ sec. Drift in the integrator circuit appears on the recorder as an equivalent power loss (except that it can have either sign), and so must be kept small. Fortunately, it can be observed when the magnet isn't being cycled, and the usual procedure is to adjust for zero drift immediately before a run, and then again immediately after a run. For magnets A and B the sensitivity of our apparatus was limited to about 100 mW by the stability with respect to drift of the integrator.

For magnet C we used a more stable integrator which contains a solid-state chopper-input operational amplifier. We have also used an integrating digital voltmeter to read the voltage remaining on the integrator at the completion of each cycle. The new method gives us the ability to measure the loss to about 0.1 J over one cycle. Typically a cycle from zero to 90 A and back to zero took about 600 sec at our slowest charge rate, which is a sensitivity of about 0.2 mW on a measurement over one cycle.

The system was calibrated in the following way. First the compensation circuits were adjusted so that the output was zero with only a current input to the Hall device (no magnetic input). Next the multiplier was used to measure power into a resistive load when a digital voltmeter was used to read voltage and current at the resistor, and also to read output voltage from the multiplier. This gave a measure of linearity and also a calibration (in millivolts output per watt input) for a given multiplier. The integrator was checked by putting a constant voltage on its input while observing the output as a function of time.

The next step was to insert a small resistor in series with a test magnet so that most of the losses would be in the resistor, but at the same time would be small compared with the reactive power in and out of the magnet when it was cycled. Separate potential leads were brought out from the resistor and from the SC magnet. The boiloff helium gas was monitored with an American Meter Co. constant-displacement gas-flow meter. A triangular current waveform was applied to the series combination of resistor and SC magnet while we monitored voltage, current, and energy in both the magnet and the resistor. There were several checks on the calibration: the calculated $\int V_R Idt$ was compared with the Hall-multiplier-integrator (HMI)

output when connected to the resistor; the stored energy, $\frac{1}{2} L I_{\max}^2$, was compared with the excursion in HMI output when connected to the SC magnet; and the power calculated from the gas boiloff was compared with electrically measured losses.

These methods of measuring stored energy and power loss agreed within a few percent, confirming the equipment's ability to measure small losses while large amounts of energy are being exchanged.

REFERENCES

1. H. London, *Phys. Letters* 6, 162 (1963).
2. R. Hancox, *Proc. IEEE* 113, 1221 (1966).
3. C. P. Bean et al., General Electric Company Technical Report No. AFML-TR-65-431, March 1966.
4. W. B. Sampson, R. B. Britton, G. H. Morgan, and P. F. Dahl, Superconducting Synchrotron Magnets, Paper presented at the Sixth International Conference on High Energy Accelerators, Cambridge, Mass., Sept. 11-15, 1967.
5. P. Smith (Rutherford High Energy Laboratory), personal communication.
6. R. E. Hintz, Performance of Superconducting NbTi and NbZr Inorganic Solenoids, UCRL-17772, Aug. 1, 1967.
7. R. Boom (Atomic International), personal communication, Feb. 1968.
8. Robert B. Meuser, William F. Chamberlain, and Roland E. Hintz, Solenoid Having a Horizontal Axis and a Room-Temperature Aperture, UCRL-18179, April 1968.

This report was prepared as an account of Government sponsored work. Neither the United States, nor the Commission, nor any person acting on behalf of the Commission:

- A. Makes any warranty or representation, expressed or implied, with respect to the accuracy, completeness, or usefulness of the information contained in this report, or that the use of any information, apparatus, method, or process disclosed in this report may not infringe privately owned rights; or
- B. Assumes any liabilities with respect to the use of, or for damages resulting from the use of any information, apparatus, method, or process disclosed in this report.

As used in the above, "person acting on behalf of the Commission" includes any employee or contractor of the Commission, or employee of such contractor, to the extent that such employee or contractor of the Commission, or employee of such contractor prepares, disseminates, or provides access to, any information pursuant to his employment or contract with the Commission, or his employment with such contractor.

