

Lawrence Berkeley National Laboratory

LBL Publications

Title

The Isotron

Permalink

<https://escholarship.org/uc/item/97s464t1>

Author

Wilson, R R

Publication Date

1952-05-01

Copyright Information

This work is made available under the terms of a Creative Commons Attribution License, available at <https://creativecommons.org/licenses/by/4.0/>

DECLASSIFIED

UNIVERSITY OF
CALIFORNIA

*Radiation
Laboratory*

TWO-WEEK LOAN COPY

*This is a Library Circulating Copy
which may be borrowed for two weeks.
For a personal retention copy, call
Tech. Info. Division, Ext. 5545*

BERKELEY, CALIFORNIA

DISCLAIMER

This document was prepared as an account of work sponsored by the United States Government. While this document is believed to contain correct information, neither the United States Government nor any agency thereof, nor the Regents of the University of California, nor any of their employees, makes any warranty, express or implied, or assumes any legal responsibility for the accuracy, completeness, or usefulness of any information, apparatus, product, or process disclosed, or represents that its use would not infringe privately owned rights. Reference herein to any specific commercial product, process, or service by its trade name, trademark, manufacturer, or otherwise, does not necessarily constitute or imply its endorsement, recommendation, or favoring by the United States Government or any agency thereof, or the Regents of the University of California. The views and opinions of authors expressed herein do not necessarily state or reflect those of the United States Government or any agency thereof or the Regents of the University of California.

UNIVERSITY OF CALIFORNIA
Radiation Laboratory

Cover Sheet
Do not remove

INDEX NO. UCRL-833

This document contains 44 pages

This is copy 10 of 10 series B

(AFCD-3373)

NNE'S Vol. IV Chap IX

DECLASSIFIED

Issued to Information Division

~~SECRET~~
Classification

Each person who receives this document must sign the cover sheet in the space below.

Route to	Noted by	Date	Route to	Noted by	Date
<i>J. Reynolds</i>	<i>FR</i>				
<i>COO</i>	<i>MD</i>				
<i>SGT</i>	<i>MS</i>				
<i>AC</i>	<i>ABJ</i>				
<i>Mabel Smith</i>		<i>no</i>			

DECLASSIFIED

Vol. IV
Chapter IX

~~SECRET~~

The Isotron

by

R. R. Wilson

DECLASSIFIED

Classification cancelled by
authority of the Office of

Declassification 5-19-82
Date *(B. F. Fokett)*

9.01 INTRODUCTION

Most methods of separating isotopes depend on the use of a large magnetic field. The isotron is an electromagnetic device for separating isotopes, but it effects the separation by the use of radio-frequency voltages instead of magnetic fields. It has the advantage that plane sources of large area can be used instead of the slit sources to which most magnetic methods are limited. Before entering into any discussion of the details a simplified description of the principles of the method will be given.

Ions from a plane source extended in two dimensions are first accelerated by a constant, high intensity electric field and are then further accelerated by a low intensity electric field varying at radio-frequency and in a "sawtooth" manner. The effect of the constant electric field is to project a strong beam of ions straight down a tube with uniform kinetic energy and therefore with velocities inversely proportional to the square root of the masses of the ions. The varying electric field introduces small periodic variations in velocity having the effect of causing the ions to form plane bunches at a certain distance down the tube. Thus bunches of ions of different mass travel with different velocities and therefore become separated. The intensity of the fields are adjusted so that the ions become most completely bunched at the position of maximum separation. At this position an analyzer applies a transverse focussing electric field together with a radio-frequency component synchronized with the travel of the bunches. The synchronization is such that the varying component of the transverse field strength is zero when the bunch of ions of the desired isotope comes through and is maximum when the bunch of ions of the undesired isotope comes through. In this manner the ions of the desired isotope will be focussed into collector pockets supported at the end of the tube opposite the ion source whereas the ions of the undesired isotope will be deflected away from the collector pockets.

DECLASSIFIED

~~SECRET~~

DECLASSIFIED

~~SECRET~~

Let us rephrase this in mathematical terms. Assuming that the radio-frequency

bunching field is a sawtooth wave with a period T and a range of voltage ΔV , small compared to V the accelerating voltage, we find that bunching will occur at a distance down the tube

$$l = 2Tv \frac{V}{\Delta V} \quad (9.1)$$

We can derive this by the following considerations. First, the ions are accelerated by a constant voltage V ; hence they travel with a velocity $v = \sqrt{\frac{2Ve}{m}}$. They are then subjected to the radio-frequency sawtooth field, the effect of which is to increase the energy of the ions linearly with time from V to $V + \Delta V$ for each period of oscillation T . Since the radio-frequency voltage ΔV is small compared to V , the velocity of the ions will also be increased linearly and by an amount $\Delta v = \frac{v}{2} \frac{\Delta V}{V}$. Let us suppose that we move down the tube with ions at a velocity v . An ion which received the full bunching voltage ΔV at the end of one period of oscillation will be observed by us to move with a relative velocity Δv toward the ion that came through at the beginning of the period. We will notice that the successive bunches are separated by the bunch distance $\Delta l = vT$. Hence, when the ions accelerated at the end of the period have moved a relative distance Δl the bunching will be perfect. This will occur after a time $\frac{\Delta l}{\Delta v}$ or at a distance down the tube $l = \frac{\Delta l}{\Delta v} v$; and this can be written $l = 2Tv \frac{V}{\Delta V}$.

Now let us consider ions differing in mass by the small amount Δm . They will bunch at a slightly different position $l' = 2Tv' \frac{V}{\Delta V}$ or at a distance $\Delta l' = 1/2 \frac{\Delta m}{m}$ from the other ions. For ions of one mass to bunch together just halfway between the bunches of mass Δm greater, we must have $\Delta l' = \frac{\Delta l}{2}$ which gives the relation

$$\frac{\Delta V}{V} = 2 \frac{\Delta m}{m} \quad (9.2)$$

so that (9.1) can be rewritten

$$l = Tv \frac{m}{\Delta m} \quad (9.3)$$

Typical values of the above quantities for the uranium isotopes 235 and 238 are*:

*More convenient formulae for uranium ions are, approximately, $\Delta V = \frac{1}{40} V$, $\Delta l = \frac{1}{80} l$, $8V = (f \Delta l)^2$ where V is in KV and f is the frequency in Mc.

DECLASSIFIED

~~SECRET~~

$V = 40 \text{ KV}$, $V = 1 \text{ KV}$, frequency $\frac{1}{T} = 17.9$ megacycles, $L = 100 \text{ cm}$, and bunch distance $\Delta l = 1 \text{ cm}$.

The development of the isotron split rather naturally into the following major parts:

1. Development of ion sources
2. Acceleration of large beams of ions
3. Bunching the ion beams
4. Analyzing the bunched ion beam
5. Collection of separated isotopes
6. Extending the method to large scale production.

Work was actually carried out simultaneously on nearly all phases of the project. However, for simplicity we shall try to discuss the experiments in roughly the above order. Furthermore, we shall not discuss everything that was done, but, just to keep this report of reasonable length, only that which seemed to be most successful and most pertinent. It should be remembered that the project lasted for just one year, hence many experiments were not completed. Nearly all the work has been described in detail in a series of about 40 Princeton University OSRD Project SSRC-5 reports to which references will be made (at end of chapter).

9.02. Ion Sources

Efficient large scale operation of an isotron requires that the current density and area of the beam should be as large as possible. We envisaged a final unit with an ion beam area of about one square meter passing a total current of the order of amperes. Later we will see that space charge limits the method to current densities of less than a few hundred microamperes per sq. cm. when practical dimensions and voltages are used. Thus a source is required which will provide uniform current density of the order of 100 microamperes/cm² over a sq. meter of area. An additional desideratum is that predominantly U⁺ ions are yielded. It will be explained later that doubly and triply charged ions can also be bunched simultaneously with the singly charged ions.

From the beginning of the project about 50 percent of the endeavor went into ion source research. Although many attempts at novel methods of producing ions were investigated, the bulk of the work soon focused on two types of sources which seemed most promising: electron controlled arcs using pure metal vapor, and electron controlled arcs using uranium chloride vapor.

The uranium chloride sources had the advantages that they were easy to make and run, and much of the experience accumulating at Berkeley could be directly applied to them. We did build and try many different kinds of such sources. However, they had the following serious disadvantages. First, severe vacuum problems are raised by the resultant vapors and hygroscopic properties of the chloride, and secondly we found it extremely difficult to produce ion beams which were free from uranium chloride ions, which of course were not easily separated.

Sources which used uranium metal were considerably more applicable to the isotron method. Our original approach to the use of uranium metal was to try to find a refractory substance in which to heat the metal to a temperature high enough that a hot cathode arc would run in its vapor. Innumerable materials were tried but in every case the uranium destroyed or corroded its container. Another approach⁽¹²⁾ was to strike a cold cathode arc in vacuum between two electrodes one of which was made of uranium. In general it was found that such arcs were very unstable and difficult to keep in place; hence work on cold cathode arcs was abandoned.

Although tungsten was not found to be satisfactory as a containing vessel for molten uranium because of the rapid alloying of the two, nevertheless, it was soon found that tungsten could be used as a sponge for uranium⁽¹²⁾. Thus, if not too much uranium is added to a piece of hot tungsten, the tungsten maintains its shape and the uranium simply evaporates out.

This proved to be the key to the construction of a successful metal arc source, namely a hot cathode arc to a hot anode consisting of a large rod of tungsten to which small amounts of uranium could be added from time to time. As

~~SECRET~~

typical of the many forms which were constructed, consider one of the simplest shown in Fig. 9.1. A d.c. potential of about 1000 volts is applied between the filament a and the tungsten rod b. As the filament is heated, a few amperes of electrons are emitted which strike the tungsten anode with 1000 ev energy. Although the tungsten is water-cooled at its base, enough heat is developed to heat the free end white hot. The uranium wire c, about 1/16 in. in diameter, is then shoved against the tungsten until a gram or two melt. This immediately alloys and flows uniformly over and through the tungsten. Some of it evaporates, and a sufficient vapor pressure is built up so that an arc is struck between filament and anode. A constant current network in the primary of the rectifier keeps the current at about 50 amperes, while the arc voltage runs from about 10 to 30 volts. (At high voltage the network saturates and passes only a few amperes.) As the uranium evaporates out the vapor pressure becomes less, and the arc voltage is observed to rise. Eventually this trips a relay which causes the uranium wire to be pushed against the tungsten anode until enough uranium has melted to bring the arc voltage down to a chosen operating potential - say 20 volts. A shield d was found useful to keep the arc away from the insulators of the filament leads.

It was found that amperes of ~~posit~~ positive ions could be drawn from the plasma surrounding such an arc. In our application these arcs were mounted several inches behind a plane fine mesh tungsten screen to which the ions were allowed to diffuse. The ions would then be accelerated by a high voltage, 20-50 kv, between this and another screen to give a beam of high energy ions. The ion density across the screen was approximately uniform over an area, dimensions of which were comparable to the distance from source to screen. In fact for a given uniformity the distance from source to screen is easily calculable, since the ion density was found to fall off accurately as the inverse square of the distance from the source. Mass spectrographic analyses of the ions from such sources indicated predominately U^+ and U^{++} ions depending on running conditions. Typical current rations were $U^+ : U^{++} : U^{+++} = 70 : 20 : 10$.

The development of such sources was not complete. In general their life

~~SECRET~~

~~SECRET~~

was only a few hours, after which time a filament would burn out or the anode would disintegrate. The short life of the filament was due apparently to the presence of the uranium vapor. The solution to this difficulty would be to use indirectly heated cathodes. The anode life could be extended by using larger rotating anodes and controlling the feeding of uranium to it more closely. Source lifetimes of days or weeks might be feasible.

Another metal source which seemed promising was one in which cold uranium was the receptacle of the molten uranium. This was done by running an intense hot cathode arc to the center of the top of a cylinder of uranium of a few inches diameter, the periphery of which was cooled. Enough energy was dissipated at the center of the block to maintain a sufficient temperature gradient between the center and periphery to vaporize the molten metal. This source was difficult to start and was developed too late in the life of the project to be applied to an isotron.

Many other types of sources were tried, and the workers in the ion source group, which was under the direction of Prof. Julian Mack, have written a complete description of sources and their properties. (39)

Tests showed that the metal sources of all types tried were amazingly efficient. If enough current was put into the arcs (about 50 amperes), ninety to one hundred percent of the uranium vapor was ionized.

For our production from a one meter square source we visualized about four metal arcs located symmetrically about 50 cm behind a meter square plane screen, from which point the ions would be accelerated. The efficiency could be increased by using more and smaller arcs closer to the screen and by placing a second screen on the opposite side of the arcs to catch those ions going in that direction. This would require two isotron units working back to back on one source. Such a source never got beyond the design stage. Dr. L. G. Smith pointed out some desirable features of using one arc surrounded by an isotron of circular symmetry.

~~SECRET~~

~~SECRET~~

9.03 Production of large ion beams

After producing a source which provides uranium ions uniformly over a large area, it is next necessary to accelerate these ions into a high energy parallel beam. The parallelism of the ion paths must be such that ions do not get out of phase with their bunches by having to travel obliquely and hence through longer paths from source to analyzer. A difference of path length of 10 percent of the distance between two successive bunches is tolerable; this requires that the ion paths must not have a total angular spread of more than about 6°.

The geometry of a typical isotron is shown schematically in Figure 9.2. The source (not shown) is contained in the insulated cavity S. Ions from it drift to a transparent plane tungsten screen a which is shown in greater detail in Figure 9.3. They are then accelerated in the gaps between screen a and transparent grid b consisting of a number of closely spaced thin graphite strips at ground potential. A side view of this electrode is shown in Figure 9.4. Typical accelerating gap distances varied from 1/2 in. to 1 in. After acceleration the ions travelled through the buncher c and down the tube e to the analyzer f. The buncher consisted of two more grids of parallel wires aligned accurately behind the graphite strips as shown in Figure 9.4, but more will be said of it later.

The first remarkable fact observed was that it was possible, with the correct geometry of the accelerating gaps, to obtain a nearly straight, high current density beam of uranium ions. Theoretical calculations⁽²⁾⁽⁷⁾⁽³⁵⁾⁽³⁸⁾ had shown that space charge repulsion should cause such beams to diverge widely; since they did not, one was led to the conclusion that the positive ion space charge of the ion beams was neutralized by electrons or negative ions of some sort. This conclusion was confirmed by measurements of space-charge potentials by the heated filament method. Indeed we were never able to observe any space charge divergence of our beam even at the highest current densities achieved, which were of the order of 0.1 amp/cm.².

An extensive set of experiments was carried out to determine the angular divergence of the beam⁽³³⁾. On the basis of those experiments and theory⁽¹⁷⁾ we can formulate the following picture of the process of obtaining the beam of positive ions in an isotron. Before any voltage is applied to the acceleration gap, the ion plasma

~~SECRET~~

~~SECRET~~

from the source will extend throughout the whole isotron tube. If a small positive voltage is applied to the source screen and arc the electrons in the plasma will no longer be able to pass through the gap and a plasma boundary will develop. (39)

The position of the plasma surface obey Childs' Law, which for U^+ ions is:

$$j \text{ ma/cm}^2 = \frac{V_{kv}^{3/2}}{9d_{cm}^2}$$

where j is the current density in $\mu\text{-amp/cm}^2$, V is the accelerated voltage in kv and d is the distance in cms from the plasma boundary to the nearest negative electrode, which is the graphite grid in this case. As V is increased the plasma is pushed back toward the source screen which, at a high enough voltage, it eventually reaches. Since the field is very weak behind this screen the plasma stops there.

As the edges of the screen are farther from the ion source than the center of the screen, the current density will be smaller at the edges than the center and hence the plasma boundary will reach the edges first. At this stage the plasma boundary may have a nearly spherical shape and as the lines of force will diverge normally from this the beam will be seriously defocussed until the voltage is high enough to push the plasma boundary back to the screen at its center.

Let us assume that the plasma boundary is now pushed back to the source screen and is a perfect plane surface. We might ask what fields defocus the ions. First there is the irregularity due to finite spacing of the buncher grid b . R. P. Feynman⁽¹⁷⁾ has calculated that this irregularity in the accelerating field will lead to an angle of divergence of $\frac{2a}{3G}$ where a is the spacing of the buncher grids and G is the accelerating gap distance. (If the currents were not space charge limited, the formula would be $\frac{a}{2G}$). A typical value of a/G was 0.1, leading to an angular divergence of about 3° . Feynman estimated that the source screen should have an effect of the order of magnitude of $\frac{1}{2} \sqrt{a/G}$, where d is the mesh distance. The effect of lateral wires is ignored, hence the above is certainly an overestimate. For a 30 mesh tungsten screen it would give about 5° .

~~SECRET~~

A third effect could come from the random velocities of the ions as they leave the plasma. The average energy is about 30 ev, hence for an accelerating voltage of 30 kv, the maximum angle of divergence would be $\sqrt{\frac{1}{1000}}$ or about 2°.

These theoretical estimates are very useful for guiding the design. They seem to be overestimated, for under the above conditions the total divergence of the ion beam was experimentally determined to be about 2°⁽³³⁾. The scattering of the ions due to collisions with the gas was only appreciable at relatively poor vacuums (10⁻³ mm Hg).

We can summarize by saying that ion beams can be and have been obtained having large cross sections, current densities of 200-300 microamperes per cm², small divergence, and reasonable homogeneity of energy. We found it possible to produce ion beams ten times as intense as the above but we never investigated the angular divergence or the homogeneity of the energy of such intense beams.

A word should be said here about sputtering by the high energy uranium ion beams. One of our first experiments was to expose a grid made up of various materials to the beam. The sputtering effect was very pronounced and was most serious for aluminum. It decreased for copper, tungsten, iron and graphite in the order given. Graphite is by far the most resistant material to sputtering; graphite grids have been used for many hours in large beams and they then showed almost no sputtering effect.

9.04. The Analyzer

We have seen that it was possible to produce a two dimensional ion beam travelling down a tube. The ions are made to bunch after travelling some distance and at the point of bunching some sort of analyzer must be placed to separate the desired from the undesired isotope. There are many possibilities here, but we shall describe only one device; the one on which all work at Princeton was done.

The analyzer consisted of a set of parallel ribbon-like electrodes shown schematically in Figure 9.2 at f and in more detail in Figure 9.5. The principle

SECRET

of operation of the analyzer is to place d.c. voltages between the electrodes such that the beams coming through each pair of plates are brought together or, more accurately, to a line focus.

In order to separate the bunched ions with high frequency fields at the analyzer, it is necessary to confine these fields to a region somewhat smaller than the bunch distance. This was done by super imposing a high frequency voltage upon the d.c. voltages of the plates such that every other plate was grounded with respect to the high frequency fields. The high frequency voltage was applied to alternate plates through mica condensers, the r.f. being kept from the d.c. voltage supply by suitable chokes. When the r.f. voltage was applied the beam was split into two components, since in half the gaps the field was in a direction opposite to what it was in the other half. Analysis is made by applying the alternating voltage at half the buncher frequency such that at the times of zero voltage the U^{235} ions come through to the center where the collector cup was placed, and at times of maximum (plus or minus) voltage the U^{238} ions were thrown up and down.

In practice the analyzer was from ten to fifteen centimeters wide, consisting of about twenty tantalum or graphite plates supported on insulated springs as seen in Figure 9.5. The plates were about 1 cm wide and as long as the beam was wide. They were spaced about 1/2 cm apart. If the fields existed only between the plates the voltage on each plate would increase as the square of the number of plates from the center. Due to fringing fields, however, this relationship is not fulfilled, so that one has to determine empirically the voltages to give a line focus. This was not found to be difficult, and in general it was easy to bring the beam to a line focus not much wider than the distance between successive strips. A grounded wire was placed on the beam side of each plate so that the d.c. fields would not penetrate far into the beam region and slow up the ions in such a way that there would be an appreciable variation across the beam of the time that ions would reach the analyzer.

In the final unit of one meter square cross section it was proposed to place eight or ten units of analyzers, as described above, side by side to cover the large area rather than using one big analyzer which would require much too large d.c. and r.f.

SECRET

SECRET

voltages.

The r.f. voltage for the analyzer and the buncher were both obtained from a crystal oscillator from which appropriate multiples of the frequency were made. A phase changer enabled one to adjust the phase of the r.f. analyzer voltage such that the U^{235} ions would come through the analyzer as the r.f. voltage on it was zero. Of course one could also adjust this phase by making small changes in the accelerator voltage.

9.05 The Buncher

The purpose of the buncher is to modulate the velocity of the ions in time such that the ions form into separated bunches as they reach the analyzer. Ideally this could be accomplished by simply adding an r.f. voltage to the accelerating voltage. This would mean applying the voltages either to the source or to the tube, both of which have considerable capacity. We found it more convenient to utilize the three grids b, c, d shown schematically in Figure 9.2 and in more detail in Figure 9.4.

To apply the voltage to the ions, the principle of the r.f. linear accelerator was used. This takes advantage of the time of flight of the ion through the gaps between grids. The r.f. buncher voltage is applied to the central grid c, the other two grids remaining at ground potential. The ion may be accelerated as it passes from the first grid to the second and then may also be accelerated as it passes from the second to the third grid, for the voltage has had time to reverse because of the ion's time of flight.

The first grid, as we have seen, was also the ground electrode of the accelerating gap. It is possible to obtain the same results using only two grids. In this case the r.f. voltage is placed on the first grid while grid c is grounded and grid d is eliminated. The source screen then is grounded for r.f. and plays the same role as grid b played before. In practice the three grid bunches were always used so as not to introduce complications in the experimental work.

We have already seen that the ions sputter most materials except graphite

SECRET

DECLASSIFIED

~~SECRET~~

rather seriously. It was for this reason that the ~~first~~ buncher grid b was made of graphite strips. The other grids were sometimes made of tungsten wires, but these were carefully aligned behind the graphite strip so that no beam struck them (see Figure 9.4). In later designs all the grids were made of graphite strips. It was not difficult to machine the graphite into strips 10 mils thick by 3/16 in. wide by one meter long. Their position was determined by grooves cut in a supporting bar and they were kept under tension by individual springs g as shown in Figure 9.4.

The best bunching results when the velocities of the ions are modulated in a sawtooth manner. We approximated this by synthesizing such a wave from harmonics. It is obvious that to approximate a sawtooth modulation of velocity, a sawtooth voltage need not be applied to the central electrode of the buncher shown in Figure 9.4. The actual contribution of any harmonic will depend on the geometry of the buncher grids and the velocity of the ions. In practice we were able to apply four harmonics separately to the buncher electrode, the amplitude and phase of each harmonic being separately variable. First, the fundamental would be applied, and its effect on the production of bunches, observed on an oscillograph by using an electronic device, was maximized by varying the phase and amplitude. Then a second harmonic would be added and its effect on the bunching would also be maximized by varying its phase and amplitude, as well as by readjusting the phase and amplitude of the fundamental or first harmonic. In the same way the other harmonics would be added, and all phases and harmonics finally trimmed for best bunching. One readily acquired a feeling for making this adjustment.

Feynman has worked out the theory of the design of bunchers. ⁽¹⁷⁾ This theory gives us the dimensions of the buncher grids as well as the amplitudes and phases of the harmonic voltages. It is obvious that the dimensions between grids and between strips of a given grid must be of the order of the distance an ion travels during a period of the highest harmonic. The theory recommends for four harmonics a buncher consisting of two electrodes of grounded graphite strips of

SECRET

length approximately $\delta/8$ (δ is the bunch distance), with the ~~plates~~ applied to a set of wires midway between the plates and on a line with them. The center of the plate electrodes should be a distance $(3/8)\delta$ apart so that the wire is about $\delta/8$ away from the edge of the plates. The spacing of adjacent plates should be $\delta/8$. Actually two harmonics were usually adequate for good bunching so that the above dimension could be increased by a factor of two if it were desirable.

9.06 Bunching Ions

A. Low Current Density

In the simplified description of the principle of the isotron, a perfect sawtooth wave form was assumed for the velocity modulation. We have seen in the preceding section how such a wave form was approximated by adding harmonics. Let us now see how these approximations affect the separation and efficiency of an isotron.

Feynman⁽⁴⁾ finds theoretically that it is possible to get complete separation even without a sawtooth wave form if ions accelerated in part of the cycle are thrown away. In general we must choose between efficiency and degree of separation. If the separation factor σ is defined as the factor by which the ratio of heavy to light isotope is decreased and the efficiency η as the fraction of one cycle that is used, he finds that even for pure sine waves typical values of $\sigma = 16$, $\eta = 60$ percent, or $\sigma = 10$, $\eta = 70$ percent can obtain. For a wave form made up of four harmonics, he finds $\sigma = 44$ at $\eta = 84$ percent. If higher harmonics are used, $\sigma = 17N$ and $\eta = \frac{2N}{2N + 1}$ where N is the number of harmonics used. Most ion sources produce ions of different charges. In particular, we saw that the metal source usually made U^+ , U^{++} , and U^{+++} ions in the ratio 70:20:10. Fortunately, it is possible to bunch and separate all three of these ions simultaneously.

First let us consider only the two ions U^+ and U^{++} . The U^{++} will be accelerated to twice the energy and hence $\sqrt{2}$ times the velocity of the U^+ .



Now the ratio of the energy received by the ion to the voltage put on the buncher⁽¹⁷⁾ depends on the velocity of the ion through the buncher, and on the geometry of the buncher. It was found possible to design a buncher in such a way that both the U^+ and the U^{++} receive the proper bunching voltage so that both have the minimum width at the analyzer. The difficulty now is that although both ions bunch at the analyzer, they travel with different velocities, and so in general do not arrive at the analyzer at the same time. However, for a suitable choice of tube dimensions it was possible to arrange it so that the U^+ ions and the U^{++} ions arrived at the analyzer in coincidence for several unique values of the accelerating voltage. It is clear that this would be done by allowing the U^+ ion bunch to lag behind the U^{++} ion bunch by an integral number of bunch distances. Paul Olum⁽²⁸⁾ has worked out the complete theory of this process and has extended it to the case of three types of ions.

Two groups working on two separate experimental isotrons did many experiments on bunching at low current density, about one microampere/cm². First, a group under the leadership of J. L. Fowler, constructed a $4\frac{1}{2}$ in. diameter isotron tube⁽¹⁹⁾ which was later rebuilt as an 8 in. diameter tube⁽³⁴⁾. On the basis of results from the small isotron, another group under the leadership of L. G. Smith constructed a 12 in. diameter isotron; the principal emphasis of this group was to study bunching at high current density. However, this necessitated considerable work at low current density⁽³²⁾.

Let us consider the experimental procedure in examining the bunching in an isotron. The ion source would be turned on and the accelerating voltage (about 10 to 40 kv controlled electronically to within a few volts) was applied. This produced a straight beam of ions down the tube. Next the analyzer d.c. voltage would be turned on and adjusted such that most of the beam was focused into a narrow collector cup g located some distance behind the analyzer as shown in Figure 9.2. Then the r.f. analyzer voltage would be turned on. This caused the line focus to be spread out in a perpendicular direction about five

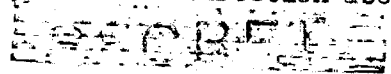

~~SECRET~~

or ten times the width of the collector cup. This of course caused a decrease in the current measured in the cup. The crucial point came as the buncher voltage was applied and the phase between buncher and analyzer was changed or when small changes were made in the accelerating voltage. If there was any bunching, it would show up as an increase or decrease in the current to the cup, depending on whether the bunch arrived at the analyzer at zero voltage or not. It is easy to see that the separation factor obtainable is just the ratio of the maximum current to the minimum. One would then proceed to maximize the bunching or σ by making changes in the variables at ones command.

An experimental study was made of the dependence of σ on the following variables: acceleration voltage, distance between buncher and analyzer, arc conditions, gas pressure, beam size, beam current, frequency, analyzer voltages, as well as number, size and phase of harmonic buncher voltages.

In most of the experiments the separation was not measured in the simple way described above, but a mechanical scanner was used. This was located at the position of the collector cup and consisted of a slit which was moved recurrently at high speed in front of an ion collector electrode. The direction of motion of the slit was perpendicular to the beam direction and perpendicular to the line focus. The ions coming through the slit produced a voltage on the electrode which was impressed on the vertical plates of an oscillograph, the sweep of which was synchronized to the recurrent motion of the slit. This produced a picture on the oscillograph of the distribution of the ions in a plane at the focus of the analyzer. With all analyzer voltage off one would see a uniform distribution across the tube. Turning the d.c. analyzer voltage on caused this to form into a single peak at the center. The r.f. analyzer voltage then spread this peak out into the familiar pattern obtained by projecting a circle onto a line, namely, low at the center and with two peaks at both extreme sides. Turning the buncher voltage on caused the distribution to change

~~SECRET~~

~~SECRET~~

such that a peak appeared in the center again or such that all the current went to the sides depending on the phase between buncher and analyzer. The separation factor was determined by measuring the maximum height at the center when the peak appeared there to the minimum height at the center when the peaks were made to appear at the sides. The motion of the slits was obtained by rotating a large drum in the vacuum through a sliding seal.

The results of a typical experiment performed in the 8 in. diameter isotron will be given below ⁽³⁴⁾. The buncher fundamental frequency was 6.5 mc, the analyzer frequency was 3.25 mc and its voltage was 1200 volts rms. The accelerating voltage was about 20 kv so that the distance between successive bunches was about 2 cm. To bring the centers of gravity of the U^+ and the U^{++} bunches together at the analyzer and place the U^{235} bunch midway between the two U^{238} bunches required 81.8 bunch distances between buncher and analyzer or a distance of 160 cm. Other coincidences of U^+ and U^{++} bunches were predicted at 21.7 kv and 18.4 kv for this frequency. The vacuum was about 10^{-5} mm Hg.

The best bunching was obtained as follows:

One harmonic: $\sigma = 6.8$, bunches voltage $E_B = 145$ r.m.s. volts

Two harmonics: $\sigma = 14.5$, $E_{B_1} = 115$ volts r.m.s.

$E_{B_2} = 17$ volts r.m.s.

Three harmonics: $\sigma = 25$, $E_{B_1} = 130$ volts r.m.s.

$E_{B_2} = 31$ volts r.m.s.

$E_{B_3} = 20$ volts r.m.s.

No definite increase in σ was obtained by adding the 4th harmonic, although the pattern on the scanner sometimes seemed slightly improved.

Figure 9.6 shows the result of an experiment to determine the effect of the accelerating voltage on the separation factor. The maximum which occurs at 19.6 kv is probably the coincidence of U^+ and U^{++} which was predicted at

~~SECRET~~

~~SECRET~~

20 kv. The voltmeter read 3 percent too low at 3 kv, so the agreement is rather good. The difference in accelerating voltage between this maximum and the next is 1.7 kv, compared to the 1.6 kv predicted by theory.

Measurements of σ as a function of r.f. analyzer voltage showed that the separation factors could have been perhaps doubled by increasing the analyzer voltage to about 2500 rms volts.

By allowing air to flow into the system at various rates with an adjustable leak, the curve of Fig. 9.7 was obtained. The pressures were read on a W.E. D-79510 ion gauge using an emission current of 10 ma. Hence each microampere of the abscissae corresponds to about 10^{-5} mm Hg. The theoretical curve was obtained from calculations by Feynman on the basis of collisions of the U^+ ions with the atoms of the gas⁽³⁵⁾. In order to fit the theoretical curve to the data it was necessary to guess the best value of ρ , the pressure at which 1/e of the ions suffered collisions in travelling to the analyzer. A value of $\rho = 8.3$ microamperes fits the data best.

Figure 9.8 shows the result of an experiment made on the 12 in. diameter tube, the purpose of which was to determine the effect of buncher voltage (fundamental only) on the separation factor. The frequency was 7.5 mc/sec, accelerating voltage was 21.4 kv, and the distance from buncher to analyzer was 160 cm. The current density in the run was $30 \mu\text{amp}/\text{cm}^2$. The curve of σ vs. E_B (the buncher voltage) shows four maxima at $E_B = 120, 370, 570,$ and 800 volts; the corresponding values of σ were 4.8, 2.2, 1.85 and 1.45. The phase of the buncher voltage was the same for alternate peaks but differed by 180° from one peak to the next. These results were beautifully verified by the calculation of Feynman⁽³⁵⁾, on "high order" bunching. His calculated curve is almost identical to the experimental one.

~~SECRET~~

~~SECRET~~

B. High Current Density

Originally we had piously hoped that the space charge in the buncher would be neutralized in the same manner in which we have seen that the space charge of the beam itself was neutralized. Alas, such was not the case; indeed we were never able to observe any indication of even partial neutralization of the debunching space charge. Apparently this was because the electrons or more plausibly the negative ions that provide steady space charge neutralization are unable to follow the radio frequency changes in the electric field produced in the bunches.

This fact, learned the hard way, caused us to reorient our thinking down from isotrons of one square meter area working at low V on beams of hundreds of amperes to the condition mentioned earlier in the chapter where debunching space charge effects were not important, namely about one ampere per square meter or per tube and high V. Our original confusion came about because we seemed to observe higher values of σ than seemed possible at the large currents. These values of σ were not very large (~ 2 or 3), and, because at that time we were unable to produce straight beams of ions in the isotrons, we ascribed the low σ to geometrical effects. Later when these were corrected and we still obtained low values of σ a series of experiments ⁽³²⁾ soon convinced us that space charge was responsible for our inability to obtain larger separation factors at high current densities.

Calculations by Feynman ⁽²⁾ and Olum ⁽³⁸⁾ have shown that if there is no space charge neutralization then the current density will be limited to values below a critical current density given by the following formula

$$j = \frac{1250 \text{ V}^{3/2} \text{ KV}}{L^2 \text{ cm}} \quad (9.4)$$

where α is the ratio of $\frac{e}{m}$ of the ion to that of the U^+ ion. They further showed that if several ions were present in the beam, they would act independently of one another ⁽²⁸⁾. Thus, for nearly equal currents of U^+ and U^{++} ions, the

~~SECRET~~

~~SECRET~~

limiting value of the current density would be given by

$$j_1 = 3000 \frac{V^{3/2}}{L^2} \quad (9.5)$$

The results of the experiment carried out on the 12 in. isotron to determine the effect current density has on the separation factor are shown in Figs. 9.9 and 9.10. For Fig. 9.9 the distance L was 160 cm, the accelerating voltage was 20.9 kv, and the buncher frequency was 7.5 mc. The calculated limiting current density is about 13 $\mu\text{a}/\text{cm}^2$, and it is seen that this is in good agreement with the experimental values shown in Fig. 9.9. In the case of Fig. 9.10, L was decreased to 99 cm, but f was still 7.5 mc. The value of the limiting current density given by theory was then 40 $\mu\text{a}/\text{cm}^2$ which is also in good agreement with the data exhibited in Fig. 9.10. The two curves of σ against j corroborate the evidence given by Figures 9.9 and 9.10, for example⁽³²⁾, when L was shortened to 80 cm, and V was 20.9 kv, and f was raised to 15 mc, σ was constant up to about 65 $\mu\text{a}/\text{cm}^2$ above which it dropped. The theoretical j_1 from equation (9.5) is about 50 $\mu\text{a}/\text{cm}^2$. The largest current density about which we have experimental information was that used in the 8 in. isotron where L was 54 cm, V was 31.6 KV, and the frequency was 16 mc. The theoretical j_1 was about 200 $\mu\text{a}/\text{cm}^2$ ⁽⁴¹⁾. High values of σ (5 or 6) were obtained for currents up to this order of magnitude.

It is clear from the above that if isotrons are to be used at high current densities, that is, about 200 $\mu\text{ amp}/\text{cm}^2$, the accelerating voltage and frequency must be quite high and the distance between buncher and analyzer must be quite short. Under these conditions the isotron will separate large quantities of isotopes.

Theoretical considerations by Olum⁽³⁸⁾ indicate that space charge neutralization may occur if isotrons are designed for use with high enough accelerating voltages.

9.07 Collection

In our first attempt to collect separated isotopes we simply allowed the high energy beam to impinge on a metal plate. We were not particularly surprised that the ion beam sputtered away any of the ions that came to rest

~~SECRET~~

~~SECRET~~

on the plate. In the next attempt to collect ions were decelerated so that they nearly came to rest as they came to the collector plate. If the energy of the ions was less than a few kilovolts the sputtering was not serious and it was possible to make successful collections. The decelerating potential was an additional complication, however, and it was not used in most of the collections. Instead the high energy beam was allowed to enter a deep cup and strike the back end of it. Platinum foils were placed around the sides of the cup. Almost all the material that was sputtered away from the back of the cup was then recovered from the sides of the cup which were not exposed to the direct high energy beam. In some of the collection runs, in order not to collect neutral atoms which might come directly from the source, the beam was deflected transversely into a pocket in which the collection was made in the manner just described. Both methods seem to be successful.

Our first collection runs were made early in the project to check the feasibility of collection and, more important, to see whether our electric methods of observing separation factor were as sound as they appeared to be. The small current $4\frac{1}{2}$ in. diameter isotron was used and the samples obtained during the runs weighed from 50-100 μ g. The electric observations indicated a maximum separation factor of between five and six during the runs. Analysis made by Dunning and his coworkers using an α -particle and fission counting technique gave 2.7, 3.2 and 3.9 for the three samples tested. Considering the fluctuations in the operation of the unit at that time, we felt the agreement to be satisfactory.

A number of collections were made using the twelve inch diameter tube in which considerably larger samples (~ 10 mg) were obtained. However, these collections were made using very low separation factors and the results are included to show the effect of space charge on separation. The operating characteristics of the isotron for each run are shown in Table I together with the separation values obtained. In the early runs, there was

~~SECRET~~



little agreement between the electrically measured values of σ and those given by analysis. This was due partly to our technique of measuring σ electrically and to the possibility of the beam sputtering unseparated uranium into the collector cups. Improvement in the collection technique and the methods of electrically measuring σ are indicated in the last run where considerable precautions were taken. An attempt was made to make a collection using the high current density obtained when the tube was shortened and the voltage was increased to 32 KV. The attempt was abandoned, however, because of trouble with sparking and because the project was terminated at that time. Our most successful run was made using the 8 in. diameter isotron. Here a measured separation factor of 3 was obtained at a current density of 200 μ -amp/cm². The other characteristics of the run are shown in Table I.

In general it was felt that the problem of ion collection presented no insurmountable difficulties; indeed, the techniques developed at Berkeley for the calutron method at about the same time could have been applied directly to the isotron.

9.08 Large Scale Operation

It has by now become fairly clear just what an isotron can or cannot do. If we use an accelerating voltage of about 30 kv and a buncher frequency of about 16 mc, it is possible to produce, accelerate, bunch, and separate ion beams with current densities of about 0.2 ma/cm². The separation factor expected for such beams would probably be below ten and above three. Two harmonics would be adequate on the buncher, and the distance from buncher to analyzer would be about 50 cm. The U²³⁵ bunch would fall not midway between two U²³⁸ bunches but about one quarter the bunch distance from one of the bunches. In doing this we would have sacrificed separation factor for beam intensity, as this trick allows us to make the beam four times as large as if we had allowed the bunches to travel 100 cm - the distance of minimum separation between U²³⁵ and U²³⁸ bunches. Similarly, a buncher with a frequency of 32 mc would allow a 5% increase in beam intensity at the expense of a 50% increase in separation factor. This is a trade-off between beam intensity and separation factor.

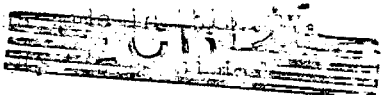

TABLE I

ELECTRICAL ANALYSIS

Run No.	Date	Beam Size	L cm	f mc	V kv	M gms	j $\mu\text{a}/\text{cm}^2$	i_1 mg	i_2 ma	m_1 $\mu\text{-gms}$	m_2 $\mu\text{-gms}$	σ_1	σ_2	σ_1	σ_2
<u>TWELVE INCH ISOTRON COLLECTOR RUNS</u>															
1	11/16/42	6"x4-1/2"	160	7.5	21.4	---	150	5.0	---	11	3	1.8	--	1.22 +04	1.12 +05
2	11/1/42	6"x4-1/2"	160	7.5	21.4	152	130	5.6	3.5	15.5	6.9	1.8	1.9	1.24 +04	1.21 +04
3	12/30/42	7-1/2" x 5-1/2"	160	7.5	21.4	272	19	.45	0.38	10.8	8.0	4.7	5.86	2.56	2.29*
4	1/9/43	7-1/2" x 5-1/2"	99	7.5	22.8	192	50	1.5	1.5	11.9	11.7	2.8	2.7	2.14	2.37
<u>EIGHT INCH ISOTRON COLLECTION RUN</u>															
5†	2/4/43	?	54.7	16.0	33.7	---	208	---	---	7.0	---	2.7	---	2.95	---

Data to be obtained from Report No. 41

† Analyzed by D. E. Hull of Columbia by α -particle and fission counting

* The material collected in the cups was converted to hexafluoride and analyzed in a mass spectroscope by R. H. Crist of Columbia University.

† Small isotron - 8" O.D.

L = Distance from buncher to analyzer.

f = r.f. frequency on buncher.

V = d.c. accelerating voltage.

j = current density in vicinity of analyzer.

M = Mass of uranium used in run.

 i_1 = d.c. current to collector cup no. 1. i_2 = d.c. current to collector cup no. 2. m_1 = mass of separated sample collected in cup 1. m_2 = mass of separated sample collected in cup 2. σ_1 = separation factor for cup no. 1 σ_2 = separation factor for cup no. 2~~SECRET~~

~~SECRET~~

cylindrical vessel about 100

cm in diameter and about 150 cm long. The buncher was to have an area of 4 square feet (24" x 24") which was also the area of the analyzer and hence of the ion beam. By the time the project was terminated the tube was constructed and evacuated to a low pressure and the high voltage supply was finished. The buncher and analyzer were nearly constructed as was the r.f. equipment. On the other hand, there was no final design of the ion source or collection system. A multiple metal ion source was envisaged, and some work had been done on proposed units.

From this point on the paper will take on a considerably more conjectural tone. Indeed, the following words are added only to complete an otherwise unfinished picture. Let us suppose that the unit would work at 0.2 ma/cm^2 . It would then pass an ion current of 0.75 amp into the collector cups when no analyzer r.f. voltage was turned on. We will also assume a separation factor of five, and that 30 percent of the current is wasted in the separation process. Let us say that the overall efficiency would be 3%, that is, 3 percent of the U^{235} fed into the source, mixed of course, would find its way into the U^{235} collector pocket. (The above is particularly conjectural as the highest experimental value was a few hundredth of a percent, although admittedly in units not designed for high efficiency.)

The question now is how would one use such a unit for the mass separation of U^{235} to high purity. Feynman has considered this problem carefully (20), (29). He finds, surprisingly enough, that in general it is better to use units of high current capacity and low separation factor than it is to use units of low current capacity and high σ . However, to get pure U^{235} with units of low σ it is necessary to utilize the units in a cascade system. Thus, Feynman visualizes the overall separation as being accomplished in a series of successive stages, each stage effecting a separation factor of σ . Because of the increasing enrichment of U^{235} the later stages will have fewer units. Thus if a σ of 5 obtains, each successive stage will have one-fifth of the number of units of the proceeding stage.

~~SECRET~~

~~SECRET~~

The operation* of a typical intermediate stage is shown in Figs. 9.11 and 9.12. For every unit of material which is put into the source the fraction, f , goes to the walls as evaporating atoms from the source, or is not otherwise collected as useful current. The useful current down the tube, $1 - f$, is collected in two samples, one which we call the "accept" in which the U^{235} is enriched, and the other the "reject" in which it is impoverished. The ratio of U^{235} to U^{238} in the accept is σ times as much as it is in the input material. We shall make the additional simplifying assumptions that the U^{235} to U^{238} ratio in the reject is just $1/\sigma$ times that in the input, and that the remaining uncollected material has the same concentration as the input. In this way, the rejected material can be put into the preceding stage along with the input to this stage without having to mix substances of differing concentrations. The "accept", of course, is sent on to the next stage.

The material which is scraped from the walls, as well as the material accepted from the preceding stage and that rejected from the next, will need to be chemically and mechanically processed and purified before it is in a form suitable to be put into the sources of the isotrons. We shall assume that for every gram of material handled by the processing equipment (including the removal of the material from the tube) a fraction λ is irrecoverably lost, leaving, for example, as fumes in the air. This loss, λ , may be expected to be a very small fraction, but the actual overall efficiency (total output of stage/total input to stage) of a single stage, which we call ϵ , may be further from 100 percent than $1 - \lambda$ if a large fraction, f , of the material put into the source is found on the walls and must be reworked. In this case the material must go through the chemical process many times before it finally makes its way into the accept or reject collection cups. The overall efficiency ϵ is given in terms of λ and f by the relation,

$$1 - \epsilon = \frac{\lambda}{1 - f + \lambda f} \tag{9.6}$$

* This discussion on the cascade use of the isotron is taken nearly verbatim from Report No. 20 by R. P. Feynman.

~~SECRET~~

As a working basis we have assumed that the total separation factor accomplished by a plant of identical machines is 10,000, so that the original concentration ratio, 1 : 140, of U^{235} to U^{238} becomes 70 : 1. (The final results are quite insensitive to this particular choice provided it is somewhere in this same range.) The total output capacity, M , of all of the machines (isotrons) in the plant (per unit output of plant) has been computed as a function of σ and ϵ , the results appearing in Figure 9.12. (It is to be noted that by the current of the machine is meant simply the total current collected by both the accept and reject cups. This is expected to be between 70 percent and 90 percent of the total current in the beam arriving at the analyzer).

The total material which goes through the chemical processes per day may also be obtained from Figure 9.12 since it is $\frac{M}{(1-f)(1-\lambda)}$ times the output of the plant. This is not accurate because it incorrectly includes the processing of the original raw material, but this is such a small fraction of the total material processed that little error is made in this way (if f is fairly large.)

We may use these curves in the following way. Suppose for a moment that there were no losses of material ($\epsilon = 1$). Suppose also that the separation factor of the machine is 10,000 so that only one stage is necessary. Then we should, of course, need a number of machines capable of handling 140 units of output current for each unit of U^{235} produced. Suppose, however, that we could put ten times as much current through the tube, but that the separation factor would thereby be decreased to only 2. Would it be worthwhile? We see from the curves that we require, at a factor of 2, about 860 times as much capacity as plant output, or only about 6 times what the capacity would be if the separation were perfect. We would thus need fewer machines (6/10 as many) with the factor 2 and would have to process only 60 percent as much material (albeit with more nuisance and care to keep partially separated fractions separately processed). If we can assume that other costs are reduced in the same ratio (the volume of

raw material required is, however, increased) we would conclude that it would be worthwhile to work with the tubes with the higher current, but poor separation factor. This example serves to emphasize the rather unexpectedly good showing of machines of low separation factor when compared with devices of much higher factor.

What happens when the efficiencies are not perfect? If the overall efficiency is 95 percent it can be seen that the machine with a factor 2 is quite impractical, while one whose factor is 2.78 is not. At 90 percent efficiency efforts should be made to obtain a factor of 4 at least. Increases of separation factor beyond this yield less and less return as far as reducing the required number of machines is concerned.

Let us work out our particular case. We suppose that one machine carries a total current of 0.75 amps to the analyzer of which only 70 percent is collected in the accept and reject cups, or the machine delivers 0.5 amp. of useful current at a separation factor of, say, 4.64. This is a capacity of 105 grams per 24 hours of operation. Suppose that, of the material which is fed into the source, 97 percent is found on the walls and only about 1/30 contributes to the useful current, so that $f = 97$ percent. Suppose also (at present no information is available on this point) that of each kilogram handled in the chemical processing one gram is lost so that $\lambda = .001$. We thus find, from Equation (9.6), with $f = .97$ and $\lambda = .001$, that ξ is about 97 percent. Looking at Figure 9.12 with $\sigma = 4.64$ we find $M = 300$.

This means that if we wish to build a plant which will produce one kilogram of 70 : 1 pure U^{235} per day with such machines, their total output capacity must be 300 times 1000 grams or 300 kg. Since each machine's capacity is about 100 grams, we shall need about 3000 such machines. (If the separation were perfect in each machine we would require 1400 machines.)

The total material processed, since $\frac{1}{(1-f)(1-d)}$ is about 30, will be 30 times 300 kg or 9000 kg. (About two-thirds of this processing is of the wall

scrapings in the first stage where the material processed has not yet been enriched. A high chemical efficiency is not required here as the losses can be compensated by using more raw material.) The total raw material required under the original circumstances, ($\lambda = .001$) it turns out, contains only 40 percent more U^{235} than is found in the product of the plant. That is to say, for a 100 gram yield of U^{235} , 20 kg of raw material with U^{235} at one part in 140 would be required.

Feynman has given in his report the curves showing the required raw material and other factors such as the time the material stands in the machine and the time for the machine to start turning out enriched material.

APPENDIX

~~SECRET~~

HISTORY OF THE ISOTRON

The isotron was invented in December 1941 by R. R. Wilson. It was developed at Princeton University under NDRC and O.S.R.D. contracts which ran from January 1942 until February 1943 under the direction of H. D. Smyth. The development was a cooperative enterprise which was only made possible by the enthusiastic support of those who participated in it. Because of the highly cooperative nature of the work it is almost impossible to give individual credit for the many inventions and developments made in the course of the project. From the list of authors of reports given at the end of the chapter, one can get some idea of the contributors to the project. However, in those reports, as here, the authors were reporting the work of several people.

The project was organized by groups. One group under the leadership of J. L. Fowler worked on a small experimental isotron. They investigated the characteristics of this isotron at low current densities. Another group working under the leadership of L. G. Smith constructed a larger isotron which was predominantly used to study/^{operation}at high current densities. J. L. Mack led a group which investigated and developed metal type ion sources. R. W. Thompson was in charge of a group which concentrated on the chloride type of ion source. R. A. Cornog was in charge of engineering and procurement, and W. A. Hane was in charge of the electronic laboratory.

The project was a happy one; an attempt was made to give all participants some voice in the determination of its policies and programmes. The large number of experiments that were finished in the short life time of the project attests to their cooperation. When it became necessary to close the project down because other methods had proved more successful, almost all the workers left for the project at Los Alamos, N.M., where they contributed significantly to the scientific work that led to the actual assembly of the first fast neutron chain reaction.

~~SECRET~~



References

Princeton University

OSRD Project SSRC-5

Number	Author	Title	Date
1	R. R. Wilson	Isotope Separator: General Description	12-15-41
2	R. P. Feynman	Effects of Space Charge; Use of Sine Waves	1-5-42
3	R. W. Thompson	Mass-Spectrographic Analysis of Electron-controlled Arc Source	1-6-42
4	R. P. Feynman	Kinematics of the Separator	4-25-42
5	R. R. Wilson	Isotope Separator: General Progress Report	3-3-42
6	J. R. B. Sutton R. W. Thompson	Preliminary Study of the Relative Abundance of the Ions Tu^+ , $TuCl^+$, $TuCl_2^+$, $TuCl_3^+$, and $TuCl_4^+$ in a Discharge of $TuCl_4$ Vapor	4-1-42
7	R. P. Feynman	The Formation of Bunches under the Influence of Space Charge	4-14-42
8	J. E. White	Corrosion of Materials in Tuballoy Chloride Ion Sources; Some Properties of the Tetrachloride and Tetrabromide	4-24-42
9	R. W. Thompson	Tuballoy Oxide Ions in a Metallic Tuballoy Discharge	4-22-42
10	P. Olum	Sputtering	4-22-42
11	R. W. Thompson A. D. Schelberg	Vapor Pressures of $TuCl_4$ and $TuBr_4$	5-4-42
12	W. M. Woodward	Metallic Sources	5-15-42
13	H. D. Smyth R. R. Wilson	General Report	5-15-42
14	R. W. Thompson J. E. White	Mass Spectrometer Investigation of Vibrator Ion Source	6-21-42
15	B. McDuffie A. D. Schelberg R. W. Thompson J. E. White	Memorandum on Preparation of TuI_4	7-14-42



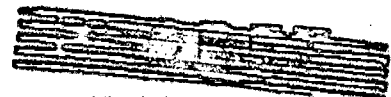

Number	Author	Title	Date
16	B. McDuffie	Possibility of Using Liquid Ammonia as Solvent in the preparation of Tubanous Salts	7-29-42
17	R. P. Feynman	The Design of the Buncher and Analyzer	8-26-42
18	H. D. Smyth R. R. Wilson	General Report	8-20-42
19	J. L. Fowler	The 4-1/2" Isotron	7-1-42
20	R. P. Feynman	A Note on the Cascade Operation of Isotrons	9-8-42
21	B. McDuffie	Attempted Preparation of Tuballoy Hexa-carbonyl	10-5-42
22	L. G. Smith	Summary of Work on the 12 Inch Isotron	10-1-42
23	R. B. Sutton	Progress on the 4-1/2" Isotron Tube	7-30-42
24	A. D. Schelberg R. W. Thompson	Saturated Vapour Pressures of $TuCl_4$, $TuBr_4$, and TuI_4	10-10-42
25	R. W. Thompson	The Production of Tuballoy Metal for an Isotron Plant I	10-10-42
26	L. G. Smith	Report of Work on the 12" Isotron December 10-19, 1942	12-31-42
27	M. B. Sampson	Report of Work on the 12" Tube December 19-26, 1942	1-3-43
28	P. Olum	The Simultaneous Use of Several Different Kinds of Ion	1-26-43
29	R. P. Feynman	The Operation of Isotrons in Cascade	1-27-43
30	E. W. Heller	Design of Sandwich Source	2-5-43
31	E. W. Heller	Estimated Costs of Buncher and Analyzer for 36" Isotron	2-9-43
32	L. G. Smith	Summary of Work on the 12 Inch Isotron (con't)	2-11-43
33	R. W. Williams	Collimation of the Ion Beam in the 8" Isotron	2-17-43
34	J. W. DeWire	Bunching at Low Current Densities	2-22-43
35	R. P. Feynman	Factors which Influence the Separation	2-22-43
36	A. D. Schelberg R. W. Thompson J. E. White	The Characteristics of an Arc in Tuballoy Tetrahalide Vapour	11-1-42

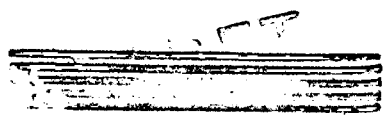

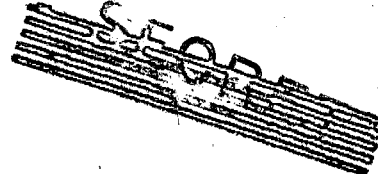

Number	Author	Title	Date
37	W. A. Hane	R. F. Equipment for Isotrons	2-25-43
38	P. Olum	An Evaluation of the Influence of Space Charge on the Operation of the Isotron	3-4-43
39	E. E. Anderson R. L. Kamm E. D. Klema J. E. Mack T. M. Snyder W. H. Surber C. M. Turner	Ion Sources	3-15-43
40	J. J. Gilvarry R. Perry B. H. Porter A. D. Schelberg R. W. Thompson	An Extended Two Dimensional Ion Source Using an Arc in $TuBr_4$ Vapor	1-15-43
41	H. S. Bridge	Experimental Work on Space Charge Debunching of Ions	3-15-43
42	L. S. Lavatelli	Metal Sources of the 8" Isotron	3-17-43
43	H. D. Smyth	Final Report	10-15-43

2

~~SECRET~~

NNES
VOL. IV - CHAPTER IX

FIGURE CAPTIONS

Figure No.

- 9.1 Typical Metal Arc Source
- 9.2 Schematic Representation of Typical Isotron Geometry
- 9.3 Detailed View of Tungsten Screen
- 9.4 Side View of Transparent Buncher Grid b of Figure 9.2
- 9.5 Detailed View of Analyzer f of Figure 9.2
- 9.6 Effect of Accelerating Voltage on Separation Factor
- 9.7 Effect of Pressure on Separation Factor
- 9.8 Effect of Buncher Voltage (Fundamental Only) on Separation Factor
- 9.9 Effect of Current Density on Separation Factor. I.
- 9.10 Effect of Current Density on Separation Factor. II
- 9.11 Typical Stage of Unit Output Capacity (Type I)
- 9.12 Number of Machines and Total Material Processed: Overall Separation Factor = 10,000 (Type I Stages)

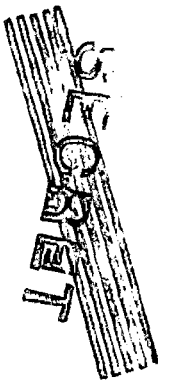
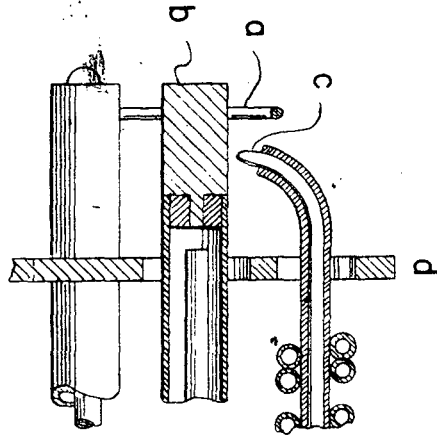
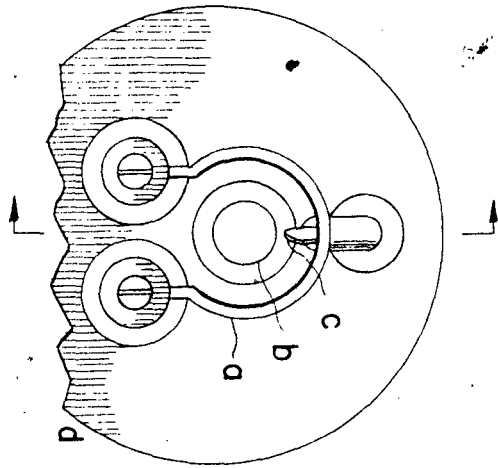

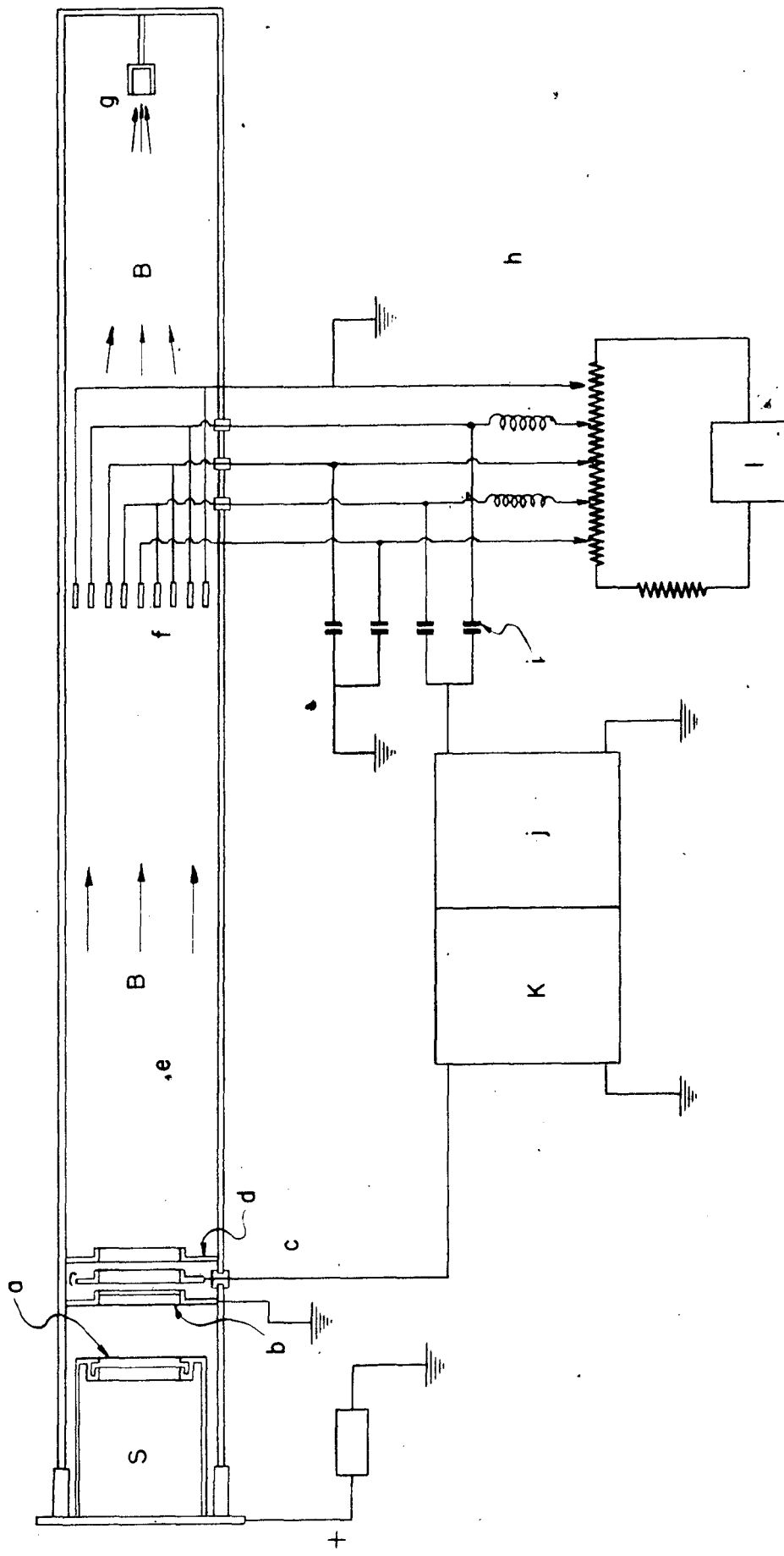

9.

SECRET

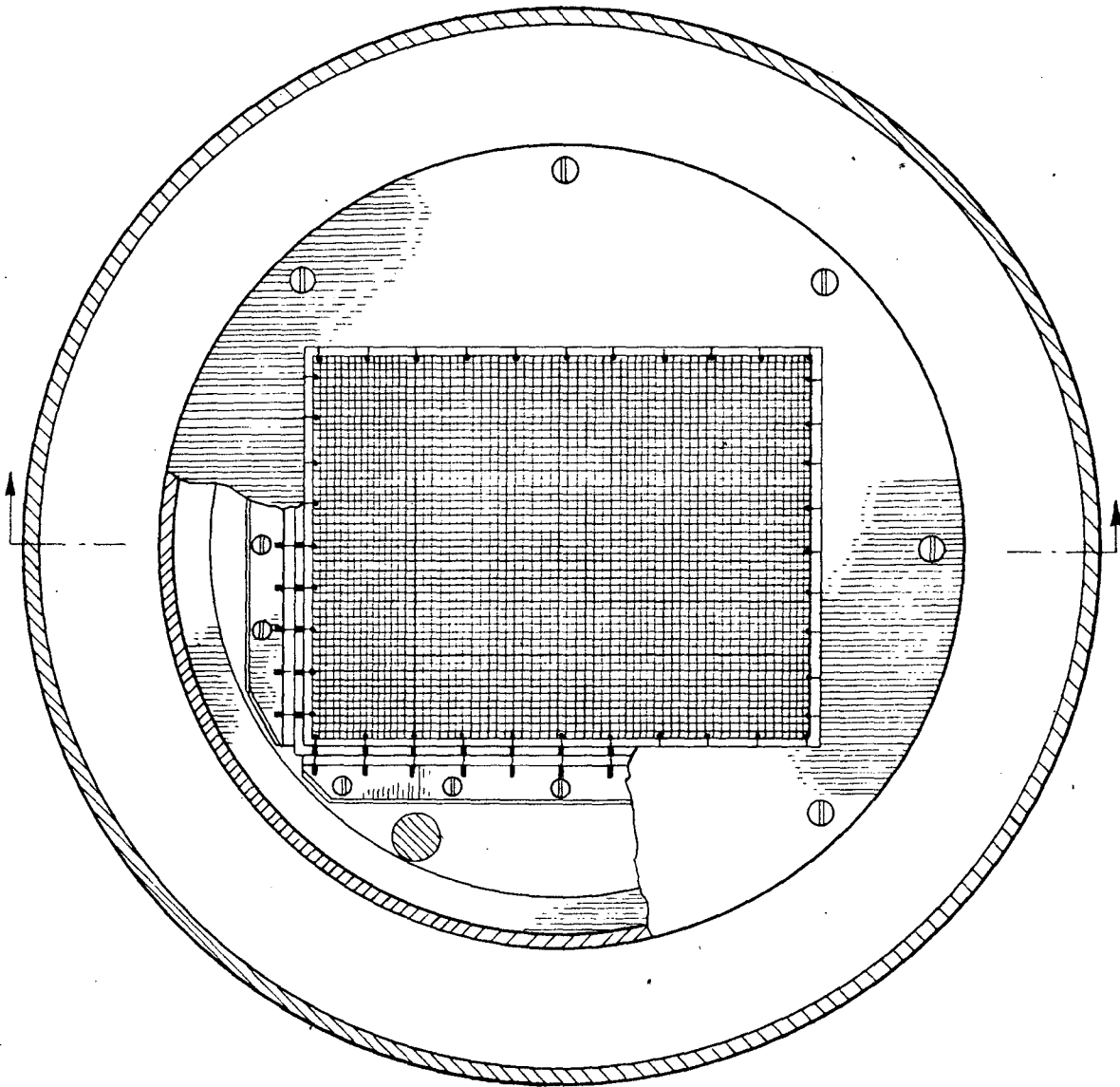
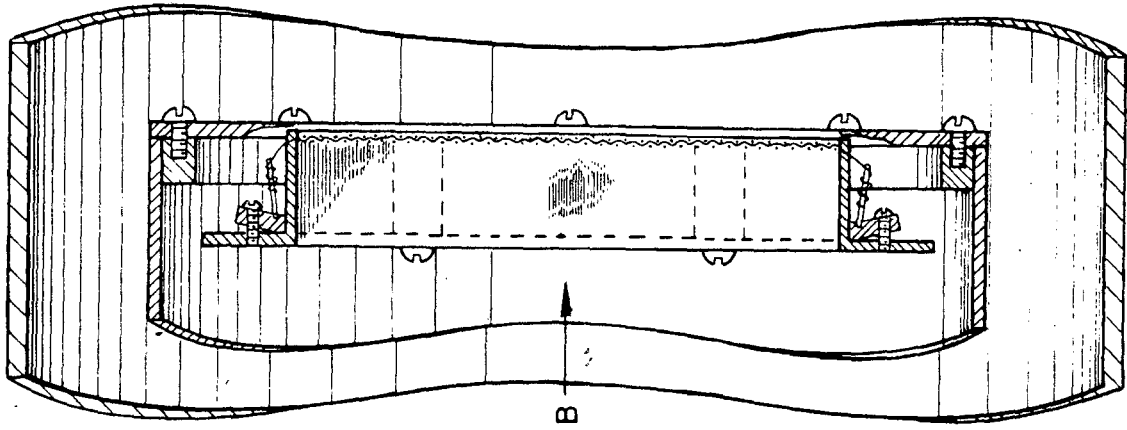

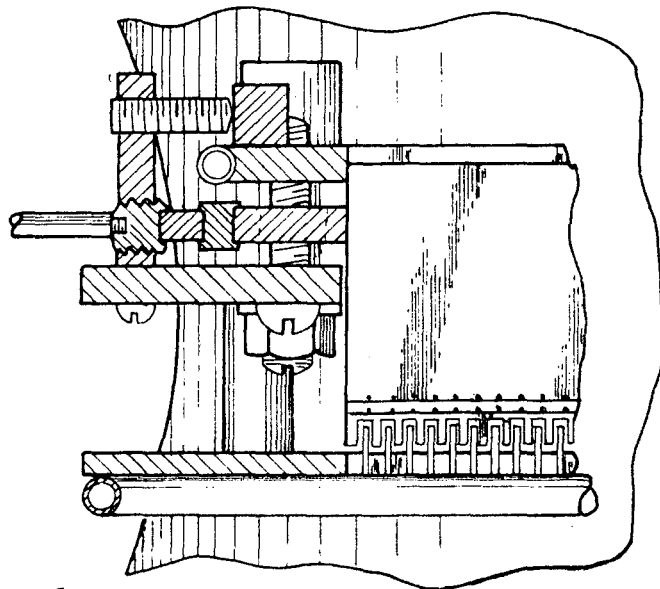
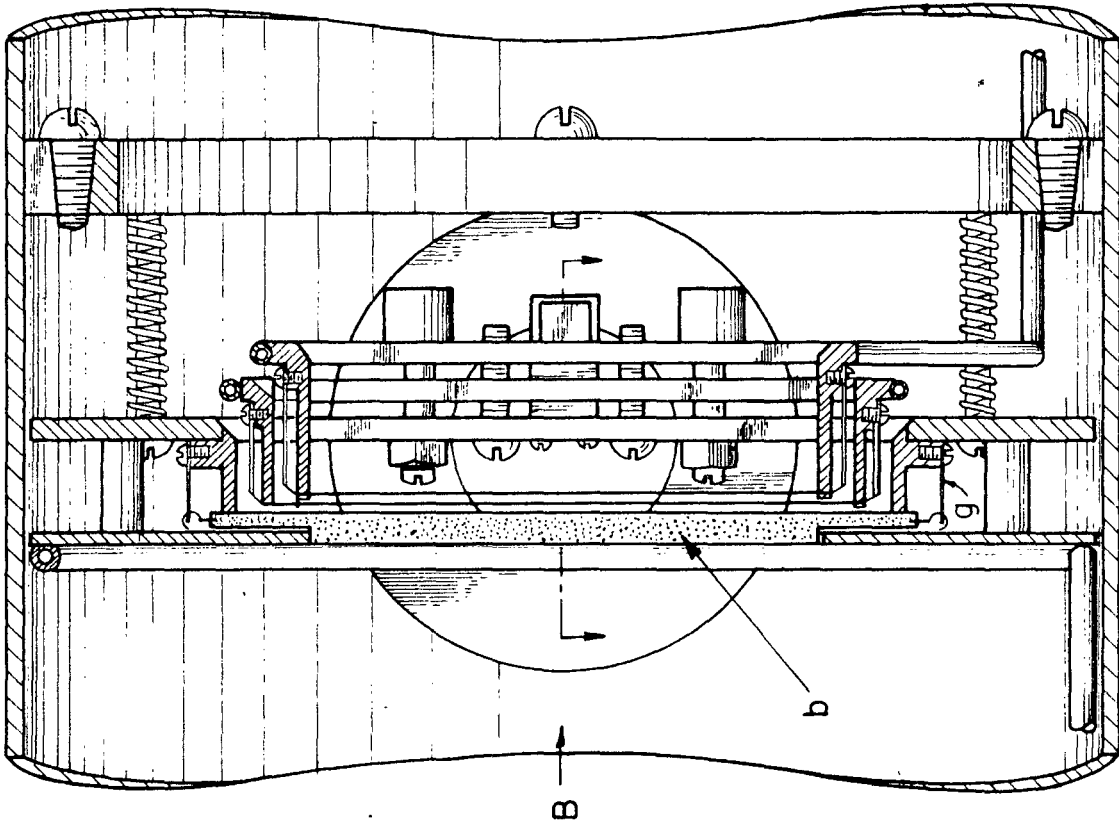

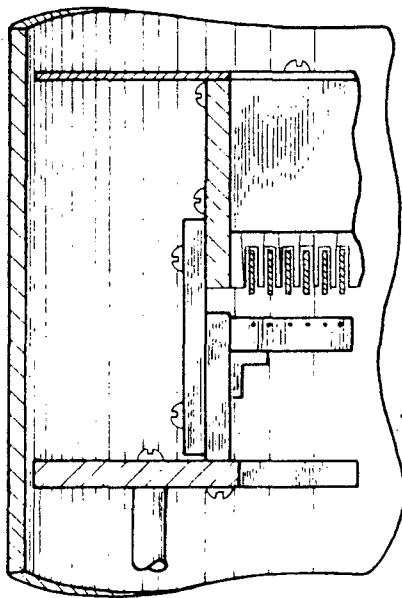
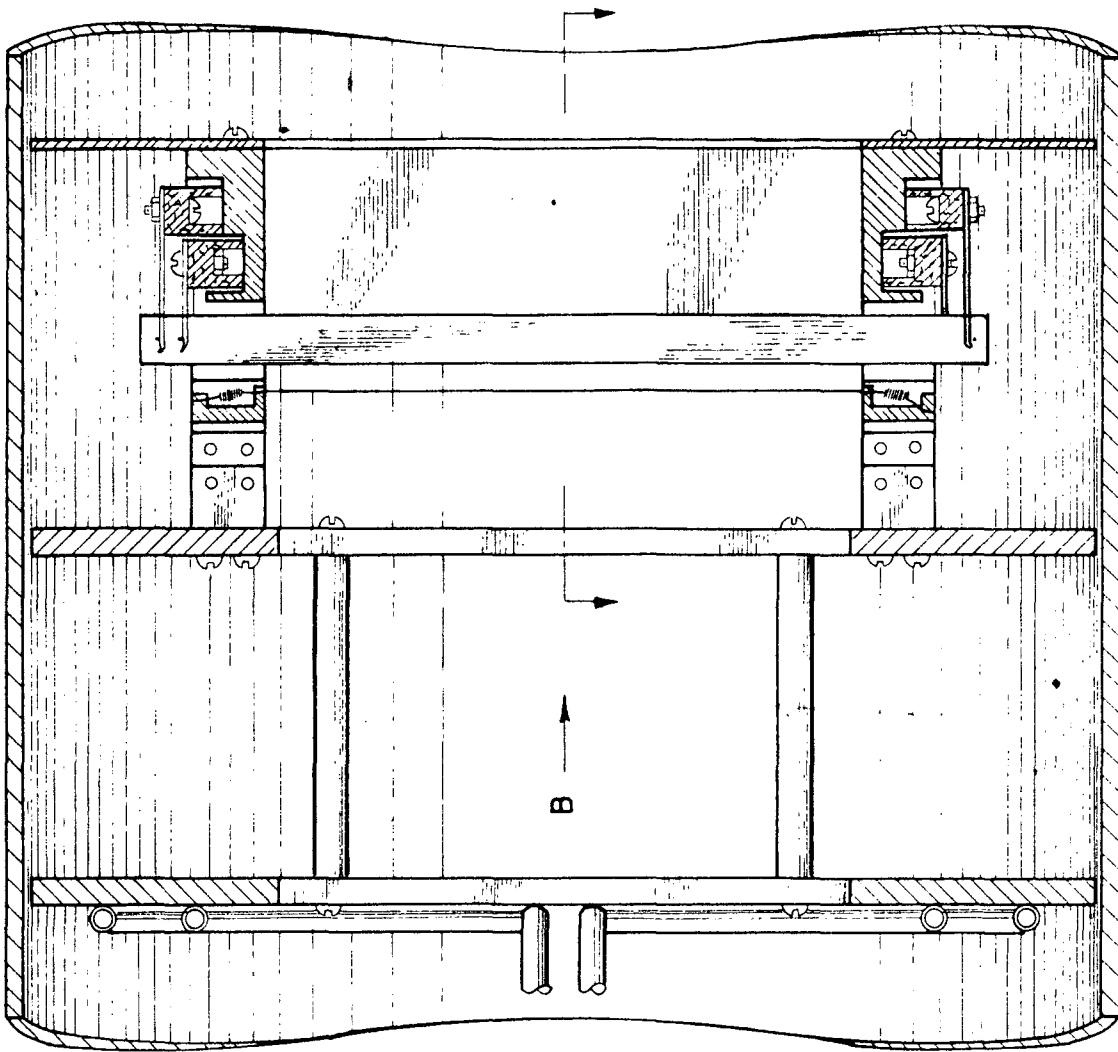

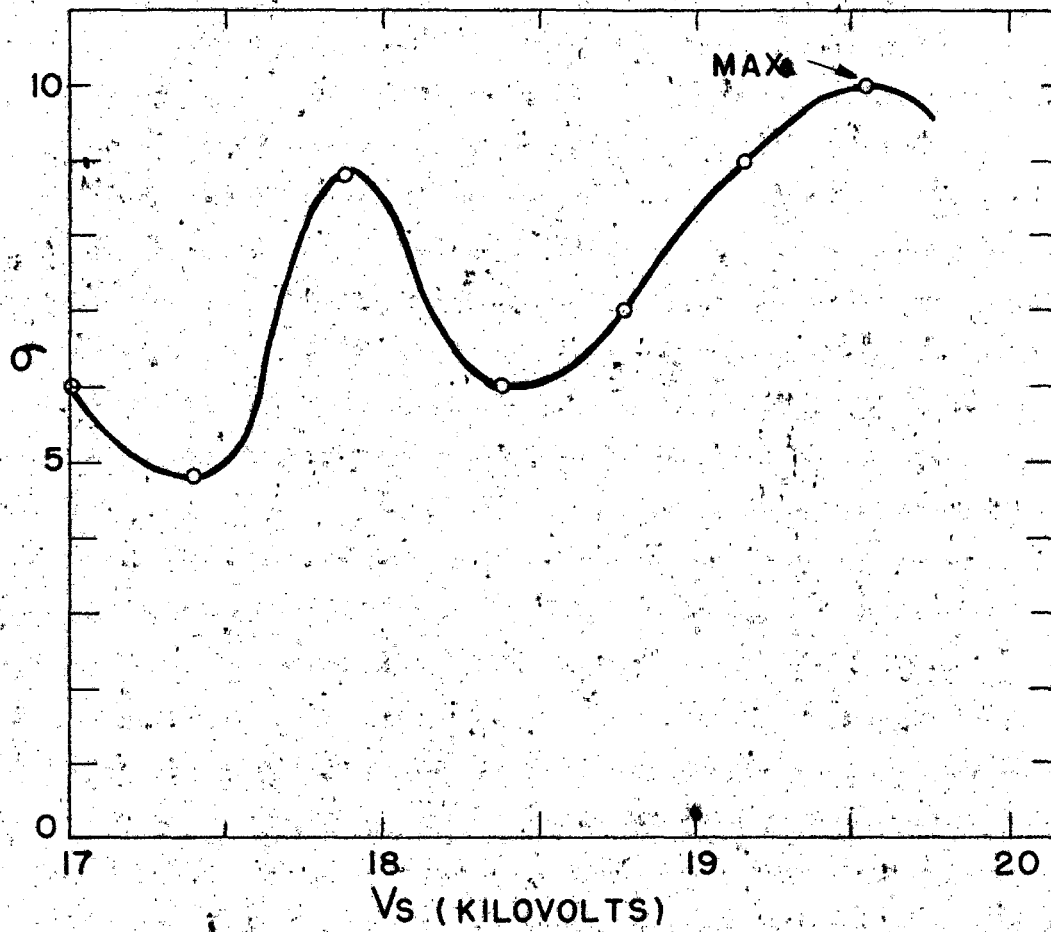

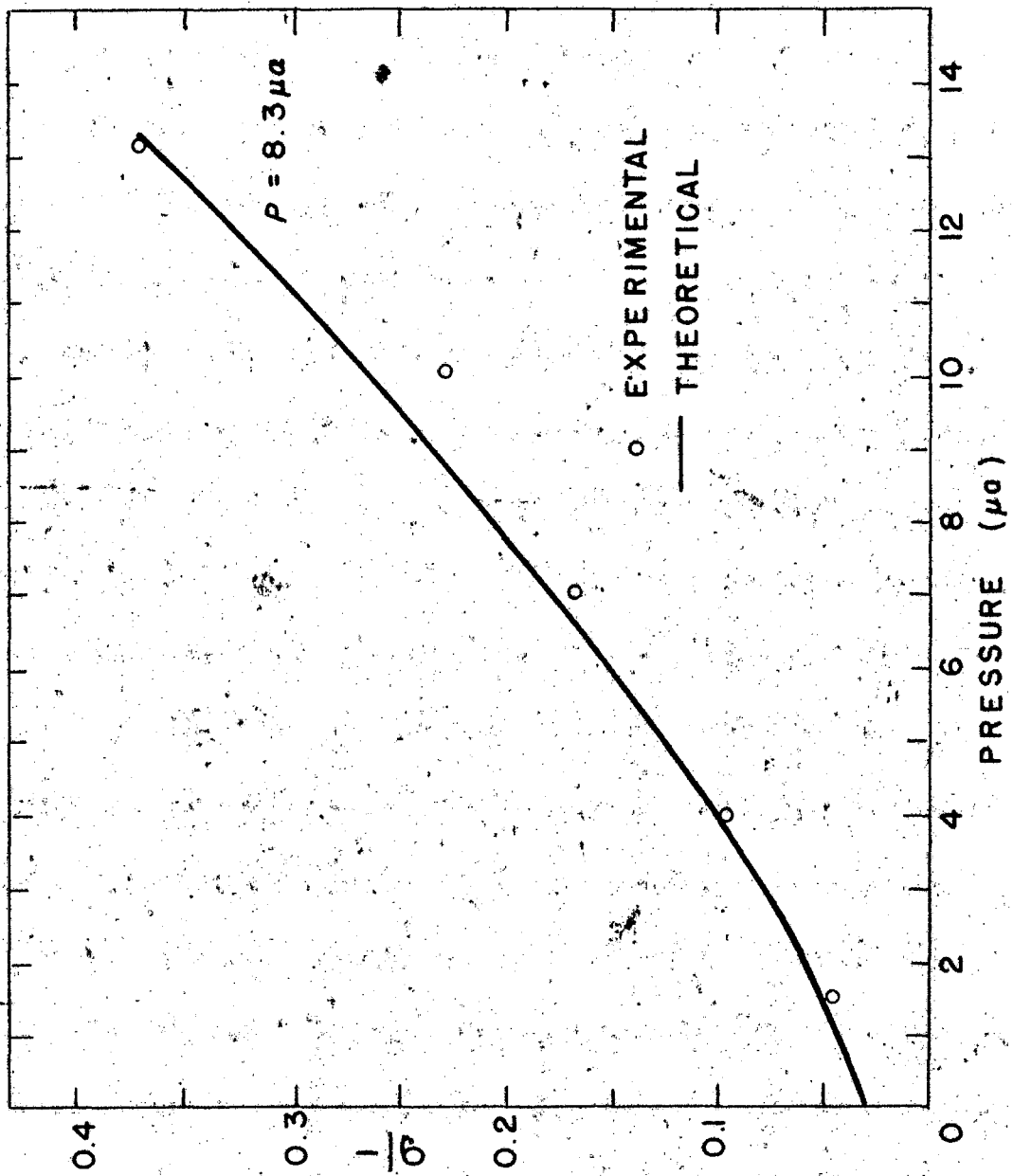

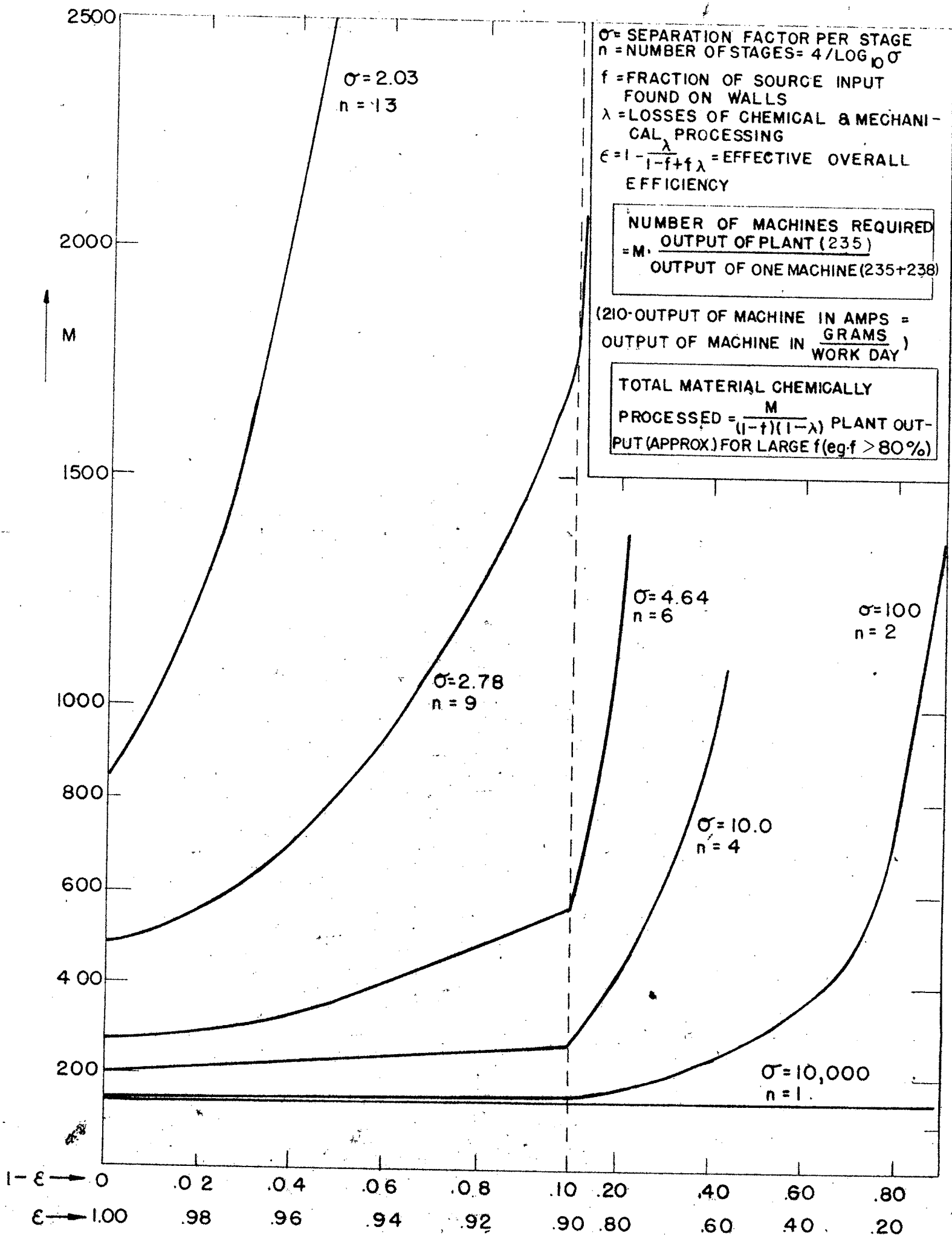

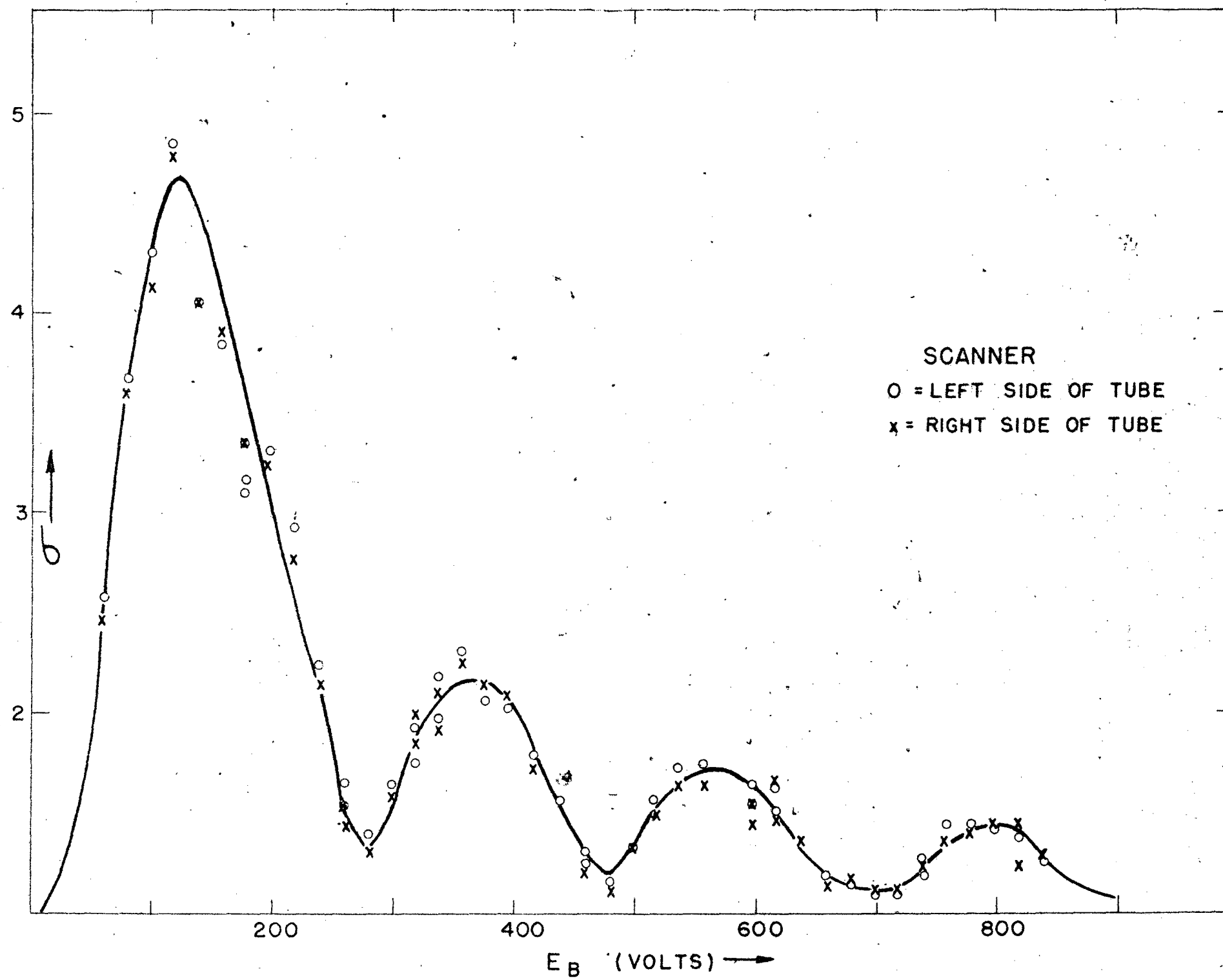

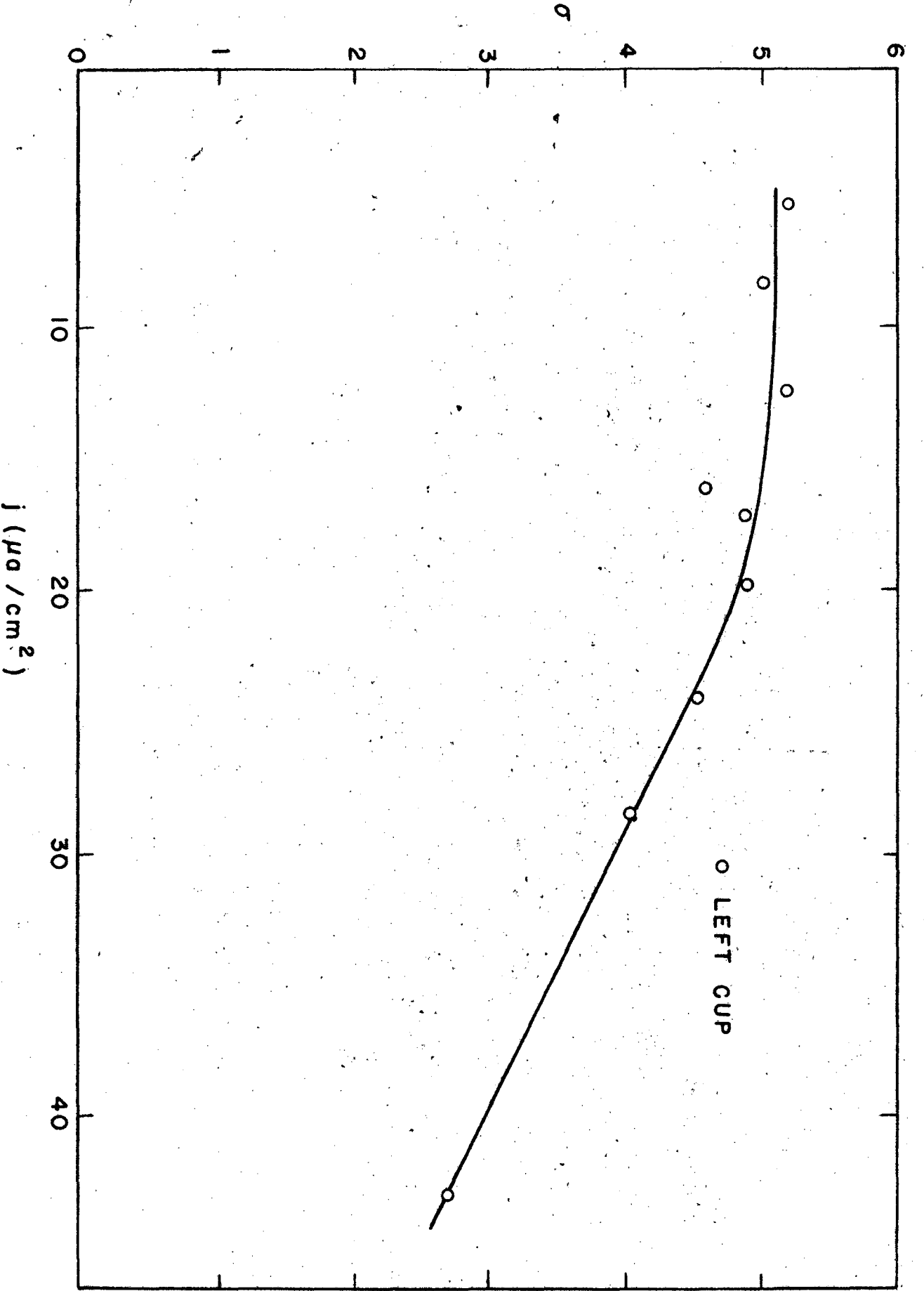

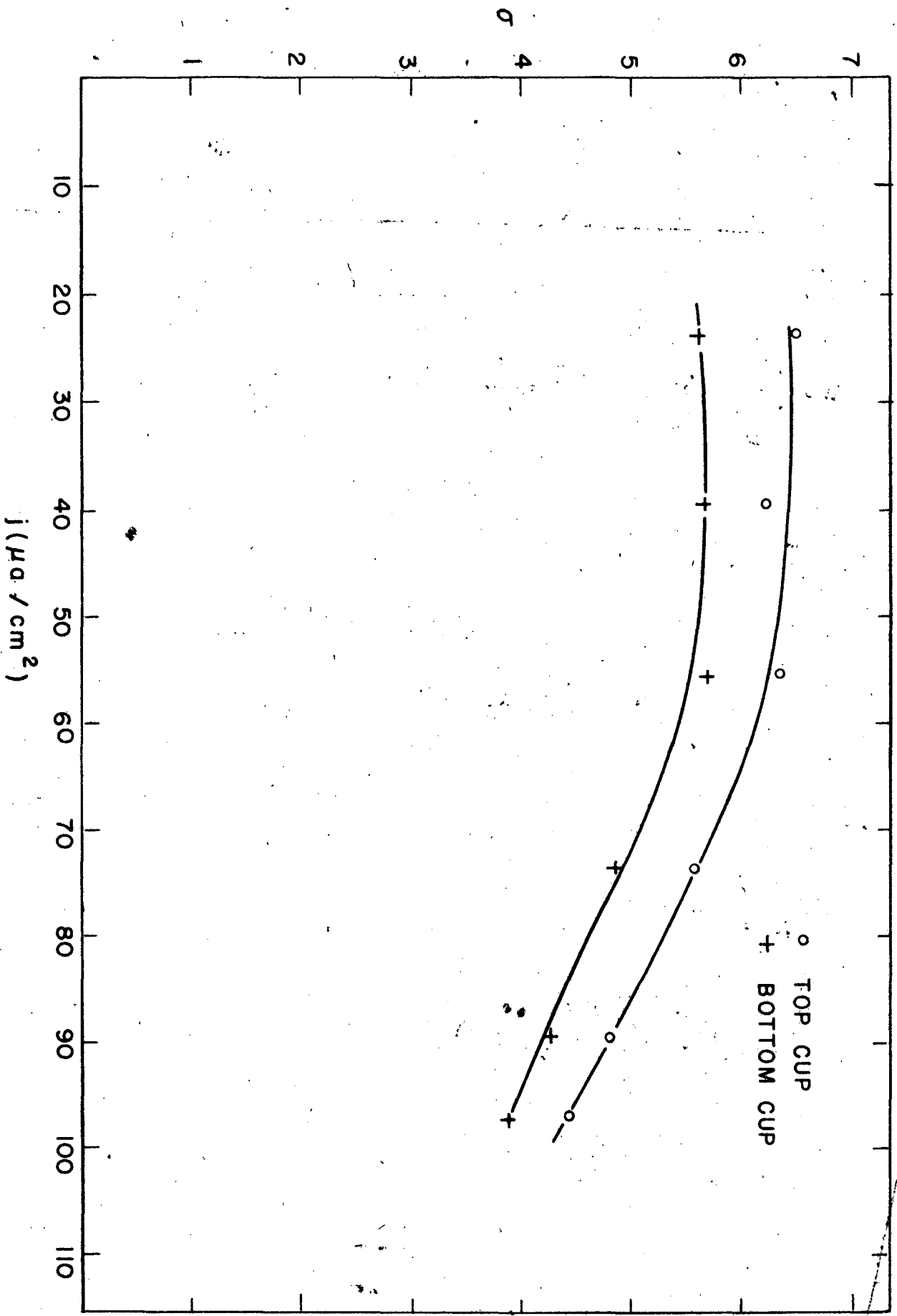

TYPICAL STAGE OF UNIT OUTPUT CAPACITY (TYPE I)

