

# Lawrence Berkeley National Laboratory

## Recent Work

### Title

DISTRIBUTION OF As, Cd, Hg, Pb, Sb, AND Se DURING SIMULATED IN-SITU OIL SHALE RETORTING. QUARTERLY PROGRESS REPORT FOR PERIOD APRIL - JUNE 30, 1979

### Permalink

<https://escholarship.org/uc/item/94z7s9d1>

### Authors

Girvin, Donald C.  
Hodgson, Alfred T.

### Publication Date

1979-07-01



# Lawrence Berkeley Laboratory

UNIVERSITY OF CALIFORNIA

## ENERGY & ENVIRONMENT DIVISION

DISTRIBUTION OF As, Cd, Hg, Pb, Sb, AND Se DURING  
SIMULATED IN-SITU OIL SHALE RETORTING

QUARTERLY PROGRESS REPORT FOR PERIOD  
April - June 30, 1979

D. C. Girvin and A. T. Hodgson

July 1979

**For Reference**

**Not to be taken from this room**

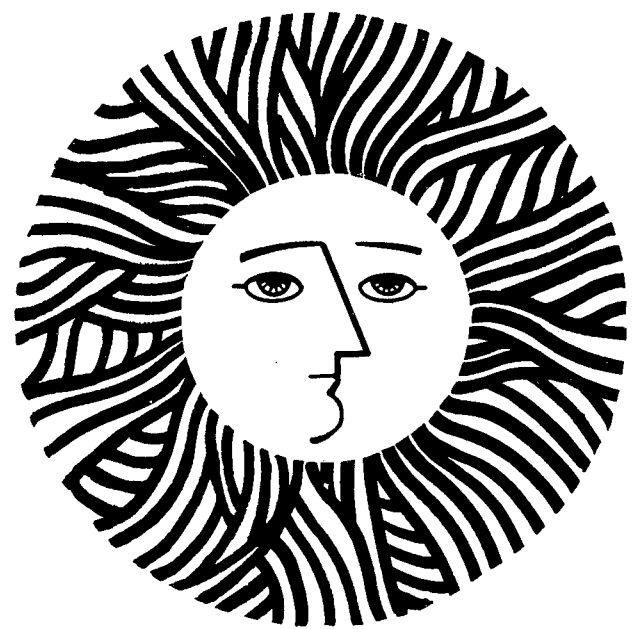

RECEIVED  
LAWRENCE  
BERKELEY LABORATORY

APR 10 1980

LIBRARY AND  
DOCUMENTS SECTION

LBID-118e.1

## **DISCLAIMER**

This document was prepared as an account of work sponsored by the United States Government. While this document is believed to contain correct information, neither the United States Government nor any agency thereof, nor the Regents of the University of California, nor any of their employees, makes any warranty, express or implied, or assumes any legal responsibility for the accuracy, completeness, or usefulness of any information, apparatus, product, or process disclosed, or represents that its use would not infringe privately owned rights. Reference herein to any specific commercial product, process, or service by its trade name, trademark, manufacturer, or otherwise, does not necessarily constitute or imply its endorsement, recommendation, or favoring by the United States Government or any agency thereof, or the Regents of the University of California. The views and opinions of authors expressed herein do not necessarily state or reflect those of the United States Government or any agency thereof or the Regents of the University of California.

Distribution of As, Cd, Hg, Pb, Sb, and Se During  
Simulated In-Situ Oil Shale Retorting

Quarterly Progress Report

for period

April - June 30, 1979

Prepared for the  
U. S. Environmental Protection Agency  
Industrial Environmental Research  
Laboratory - Cincinnati

Contract No. EPA-78-D-X0350

Technical Program Officer: Robert C. Thurnau

by

D. C. Girvin

A. T. Hodgson

July 1979

Energy and Environment Division  
Lawrence Berkeley Laboratory  
University of California  
Berkeley, CA 94720

Contract No. W-7405-ENG-48

## TABLE OF CONTENTS

|   | <u>Page</u> |
|---|-------------|
| WORK PROGRESS. . . . .  | 1           |
| Task 1. Analytical Methods for Oil and Water Samples. . . . .   | 1           |
| Task 2. Analytical Methods for Gas Samples. . . . .             | 5           |
| Task 3. Design and Construction of Experimental Apparatus . . . | 20          |
| PROJECTED WORK . . . . .  | 27          |
| REFERENCES . . . . .  | 28          |

## WORK PROGRESS

Task 1. Analytical Methods for Oil and Water Samples

Gaseous Hydride AAS Analyses. An attempt was made to analyze untreated and ozone-UV oxidized Omega-9 retort water for As, Sb, and Se using a Perkin-Elmer\* Model 306 atomic absorption spectrometer equipped with the new Perkin-Elmer Model MHS-10 Hg/hydride system and electrodeless discharge lamps. Sensitivities obtainable with the MHS-10 Hg/hydride system for As, Sb, and Se in 50 mL of sample are 0.002, 0.1, and 0.02  $\mu\text{g/L}$ , respectively (Ref. 1).

Our MHS-10 system was defective as received. Consequently, analytical precision was poor, and only very tentative data could be obtained. Since the generation system still has not been repaired by the manufacturer, we have been forced to temporarily abandon the gaseous hydride technique.

Direct AAS Analyses. In the second quarterly report, we described attempts at direct analyses of untreated Omega-9 water for As, Se, and Pb using an atomic absorption spectrometer equipped with a graphite furnace. Those early attempts, which were unsuccessful, led us to conclude that major interferences might prevent direct analyses of retort waters by flameless AAS. However, upon re-examination of the technique, we found that careful temperature control during the charring step of the heating cycle, matrix modification, and dilution of the samples by at least 1:10 eliminated interferences and allowed us to obtain linear standard additions plots.

Retort water samples from various sources were analyzed for As, Cd, Pb, Sb, and Se by flameless AAS. In general, these analyses were performed using the AAS furnace techniques presented in the new March 1979 EPA manual, "Methods for Chemical Analysis of Water and Wastes" (Ref. 2). All samples, unless noted, were first filtered using 0.4  $\mu\text{m}$  pore size, Nuclepore membrane filters. Subsequent sample preparation procedures are summarized in Table 1. Samples were analyzed using a Perkin-Elmer Model 306 atomic absorption spectrometer equipped with a Model 2100 Heated Graphite Atomizer and a deuterium arc background corrector. Instrumental parameters are also summarized in Table 1. Dilute aqueous standards were prepared daily in 1% (v/v)  $\text{HNO}_3$  with nickel or lanthanum nitrates added as required. Analyses were performed using calibration curves and by the method of standard additions.

Sensitivities, precisions, and accuracies for the flameless AAS technique are given in Table 2 along with corresponding data for the XRF technique. Atomic absorption spectroscopy sensitivity is defined as the concentration of analyte in solution that produces a 1% absorption signal. In most cases, flameless AAS sensitivity is greater than or equal to the detection limit, which is defined as the concentration that produces an absorption twice the magnitude of background fluctuation. Consequently, the AAS sensitivities

---

\* Reference to any company or product name does not imply approval or recommendation of the product by the University of California or the U.S. Department of Energy to the exclusion of others that may be suitable.

Table 1. Summary of sample preparation and instrument parameters for flameless atomic absorption spectroscopy analyses of As, Cd, Pb, Sb, and Se in retort water samples.

|   | Element            |        |        |                    |                    |
|---|--------------------|--------|--------|--------------------|--------------------|
|   | As                 | Cd     | Pb     | Sb                 | Se                 |
| <u>Sample Preparation</u>                 |                    |        |        |                    |                    |
| Dilution                                  | ≥1:10              | 1:10   | ≥1:10  | 1:10               | ≥1:00              |
| HNO <sub>3</sub> (%)                      | 1.0                | 1.0    | 1.0    | 1.0                | 1.0                |
| Ni <sup>+3</sup> (%)                      | 0.1                | ---    | ---    | 0.1                | 0.1                |
| La <sup>+3</sup> (%)                      | ---                | ---    | 0.4    | ---                | ---                |
| <u>Instrument Parameters</u> <sup>1</sup> |                    |        |        |                    |                    |
| Wavelength (nm)                           | 193.7 <sup>2</sup> | 228.8  | 283.3  | 217.6 <sup>2</sup> | 196.0 <sup>2</sup> |
| Background Correction                     | yes                | yes    | yes    | yes                | yes                |
| Purge Gas                                 | Ar                 | Ar     | Ar     | Ar                 | Ar                 |
| Injection Volume μL                       | 20                 | 20     | 20     | 20                 | 20                 |
| Drying Temp. °C/sec                       | 90/25              | 90/25  | 90/25  | 90/25              | 90/25              |
| Charring Temp. °C/sec                     | 900/60             | 300/60 | 400/30 | 600/60             | 700/60             |
| Atomizing Temp. °C/sec                    | 2700/8             | 2400/8 | 2700/8 | 2700/8             | 2700/8             |

1. Instrument parameters for a Perkin-Elmer Model 306 AA spectrometer and HGA-2100 furnace

2. Electrodeless Discharge Lamp used

Table 2. Comparison of X-ray fluorescence and flameless atomic absorption spectroscopy methods for analyses of As, Cd, Pb, Sb, and Se in shale oil and retort water.

| Element | Sample                    | XRF                          |   | AAS                      |   |
|---------|---------------------------|------------------------------|---|--------------------------|---|
|         |                           | Detection Limit <sup>1</sup> | Precision <sup>2</sup> at Concentration | Sensitivity <sup>3</sup> | Precision <sup>2</sup> at Concentration |
| As      | Oil <sup>4</sup>          | 0.28 mg/L                    | 3% @ 18 mg/L                            | ---                      | ---                                     |
|         | Retort Water <sup>5</sup> | 0.12 mg/L                    | 18% @ 0.8 mg/L                          | 0.05 mg/L                | 7% @ 0.7 mg/L                           |
| Cd      | Retort Water              | 1.7 mg/L                     | ---                                     | 0.5 µg/L                 | 17% @ 3 µg/L                            |
| Pb      | Oil                       | 1.1 mg/L                     | 28% @ 2.4 mg/L                          | ---                      | ---                                     |
|         | Retort Water              | 0.27 mg/L                    | ---                                     | 5 µg/L                   | 5% @ 0.11 mg/L                          |
| Sb      | Retort Water              | ---                          | ---                                     | 0.05 mg/L                | 3% @ 2.0 mg/L                           |
| Se      | Oil                       | 0.28 mg/L                    | 21% @ 0.8 mg/L                          | ---                      | ---                                     |
|         | Retort Water              | 0.06 mg/L                    | 12% @ 0.16 mg/L                         | 0.05 mg/L                | 6% @ 0.84 mg/L                          |

1. XRF detection limit defined as the larger of twice the counting error ( $2\sigma$ ) or 4% of the value
2. Precision for both methods defined as percent coefficient of variation (%CV);  $\%CV = 100\sigma/\bar{x}$ , where  $\bar{x}$  = mean and  $\sigma$  = standard deviation
3. AAS sensitivity defined as concentration producing 1% absorption
4. Oil from Lawrence Livermore Laboratory retort run S-9
5. Omega-9 retort water



are conservative estimates of detection limits and can be compared with XRF detection limits. This comparison (Table 2) reveals that the AAS sensitivities for As and Se in retort water samples, which have been diluted 1:10, are slightly lower than the XRF detection limits for these elements, while the AAS sensitivities for Cd and Pb are considerably lower than the corresponding XRF detection limits. Thus, AAS is the more sensitive method.

Analytical precision has been defined as the percent coefficient of variation (one hundred times the standard deviation divided by the mean). Coefficients of variation for AAS and XRF were calculated using samples that have been analyzed three or more times. Comparison of the precisions of the two techniques for As and Se (Table 2) shows that AAS analyses are more precise than XRF analyses. We expect, however, that further development of the XRF technique will result in slightly improved precisions for these elements (see XRF analyses). No comparisons are available for AAS analyses of Cd, Pb, and Sb.

Comparison of the results of AAS and XRF analyses provides an indication of the accuracy of the two methods. Analyses of three new, and as yet uncharacterized, reference synfuel waters for As and Se by both methods produced results which are approximately equivalent (Table 3). Comparative data are not available for the Cd, Pb, and Sb.

Table 3. Comparison of X-ray fluorescence and flameless atomic absorption spectroscopy analyses of As and Se in three unfiltered synfuel water samples.

| Sample ID | Concentration (mg/L) |             |             |             |
|-----------|----------------------|-------------|-------------|-------------|
|           | XRF                  |             | AAS         |             |
|           | As                   | Se          | As          | Se          |
| AG        | 23.5 ± 0.8           | 0.81 ± 0.06 | 20.2 ± 0.7  | 0.72 ± 0.10 |
| UCG       | 1.84 ± 0.20          | 0.83 ± 0.14 | 2.25 ± 0.14 | 0.84 ± 0.14 |
| IS        | 0.85 ± 0.28          | 0.23 ± 0.06 | 0.65 ± 0.14 | ≤ 0.05      |

Errors listed are 2σ values

Agreement between the two methods for As and Se suggests accuracy; however, analyses of well-characterized reference samples are required for confirmation. Standard aqueous reference samples are not suitable for this purpose since oil shale process water is a chemically complex and highly variable matrix. Consequently, we utilized Omega-9 retort water as a further check on the accuracy of our AAS results. This water was homogenized and filtered upon collection in 1976 and was stored in 30 gallon polyethylene-lined drums at 4°C. It was subsequently the subject of a careful interlaboratory, multimethod characterization involving 13 laboratories, six instrumental

techniques, and numerous chemical methods (Ref. 3). Two subsamples of Omega-9 were filtered, then analyzed for As, Cd, Pb, Sb, and Se using the AAS methods outlined in Table 1. We were unable to obtain agreement between our results and the results of the multimethod study for any of the five elements. The observed discrepancies may be attributed to loss due to filtration, contamination, or possible subsample misidentification. The original drum of Omega-9 water will be resampled during the next quarter, and the possible sources of error will be investigated.

The results of the flameless AAS analyses of the four different retort waters for As, Cd, Pb, Sb, and Se are presented in Table 4. The concentrations of these elements, with the exception of Pb, generally fall within or very close to the anticipated ranges for retort waters (Ref. 4). Lead concentrations, on the other hand, were considerably lower than expected.

XRF Analyses. In the first quarter, we reported on the utility of LBL's energy dispersive XRF system for elemental analyses of shale oils and retort waters. Sample preparation procedures and analytical parameters were described, and the results of As, Se, and Pb analyses of three oil and two retort water samples were presented. Those results demonstrated that the XRF technique is generally adequate for analyses of As and Se in these two sample matrices, but not adequate for Pb analyses. In addition, Cd, Hg, and Sb concentrations in oils and retort waters are typically too low to be determined by XRF. Consequently, our use of the XRF system for oil and water samples will be limited to analyses of As and Se.

Discussions with the analytical chemist who operates the XRF system indicated that detection limits for As and Se in oil can not be substantially improved over the detection limits quoted in the first report because there is no readily applicable concentrating procedure. Detection limits for retort waters can be improved by analyzing only for As and Se and by increasing the counting time. In addition, the precision of water sample analyses can be improved by the use of an internal standard, such as rubidium (Rb), which has a naturally low abundance in these samples. The use of an internal standard should reduce sample preparation variations which are caused by varying sample drop size. We anticipate that these changes will result in slightly increased precisions for As and Se analyses and will allow us to more closely evaluate the relative performances of the XRF and flameless AAS techniques.

## Task 2. Analytical Methods for Gas Samples

The Hg gas monitor was field tested in May during Lawrence Livermore Laboratory's 6000 kg oil shale retort experiment, L-3. L-3 was a combustion run with a 50-50 mixture of air and steam used as the input gas. The isothermal advance rate was 1.3 meters/day. The upper half (3 meters) of the shale column was lean Colorado shale (18 gal/ton) while the lower half was rich Colorado shale (36 gal/ton). The average maximum centerline temperature during the run was 945°C. The objectives of the field test were to evaluate recent design changes made in the ZAA spectrometer following the previous experiment at LETC with a prototype ZAA (Ref. 5) and to test the new gas-handling metering system and the new calibration system.

Table 4. Results of the analyses of four different retort waters for As, Cd, Pb, Sb, and Se by flameless atomic absorption spectroscopy.

| Sample ID    | Concentration (mg/L) |               |               |           |             |
|--------------|----------------------|---------------|---------------|-----------|-------------|
|              | As                   | Cd            | Pb            | Sb        | Se          |
| LETC 150 Ton | 7.40                 | ≤0.0005       | ≤0.103        | ≤0.05     | 0.90 ± 0.09 |
| AG           | 20.2 ± 0.35          | ≤0.0005       | ≤0.005        | ≤0.05     | 0.72 ± 0.05 |
| UCG          | 2.25 ± 0.07          | 0.002 ± 0.001 | 0.026 ± 0.020 | ≤0.05     | 0.84 ± 0.07 |
| IS           | 0.65 ± 0.07          | ≤0.0005       | ≤0.005        | 1.97 0.07 | ≤0.05       |

Errors listed are 1σ values

Summary of Field Test. The retort experiment commenced at 8:30 a.m. on May 7, 1979 with ignition of the shale column occurring at approximately 10 a.m. on May 8. The experiment, which was originally scheduled to run 6-7 days (144-168 hours), was terminated 100 hours after ignition on May 12 with the lower 1.0 meter of the shale column unretorted.

A brief summary of the test is presented here. A more detailed discussion follows.

- The four-day test of the ZAA Hg gas monitoring system was highly successful. The system was evaluated and necessary modifications were made during the first half of the retort run. The remainder of the test was primarily devoted to the on-line measurement of mercury in offgas sampled both upstream and downstream of the condenser train.
- The ZAA spectrometer was found to be capable of measuring concentrations of mercury in the offgas as low as 10 to 15 ppb (here ppb is  $\mu$  moles of mercury/mole of air) with up to 85% extinction of the analytical line due to broadband UV absorption.
- Mercury concentrations in offgas sampled both upstream and downstream of the condenser train were low throughout this interrupted retort experiment. Concentrations ranged from less than 5 ppb up to 62 ppb with a ZAA detection limit of 5 ppb. Since L-3 was an interrupted run, it was not possible to determine if a large mercury peak was given off as the pyrolysis zone approached the bottom of the shale bed.
- The new dynamic calibration system functioned properly over the range of concentrations encountered. Due to the complexity of the offgas mixture, the method of standard additions was used to quantify the concentration of mercury in the offgas stream.
- The ZAA furnace was operated at temperatures of 650°C to 800°C rather than at 900°C to 950°C as originally planned. The furnace showed no signs of failure after 40 hours of use at these lower temperatures, with offgas concentrations of H<sub>2</sub>S varying between 1 and 2.5% by volume.
- Both the heated sample probe and the heated sample transport line functioned well with no clogging and no evidence of mercury loss due to condensation.

Description of Experimental Set Up and Sampling. The original gas sampling and metering system (Ref. 6,7) was modified slightly for the L-3 experiment. These modifications included the ability to sample alternately from two separate locations in the offgas stream and the elimination of the vacuum pump. The experimental set up is described in detail below.

A schematic diagram of the retort offgas plumbing system, including sampling ports and the heated transport lines, is presented in Fig. 1. The hot offgas exits the retort and passes through the oil separator prior

SCHEMATIC OF 6000 kg LLL RETORT AND SAMPLING PORTS FOR ZAA Hg ANALYSIS

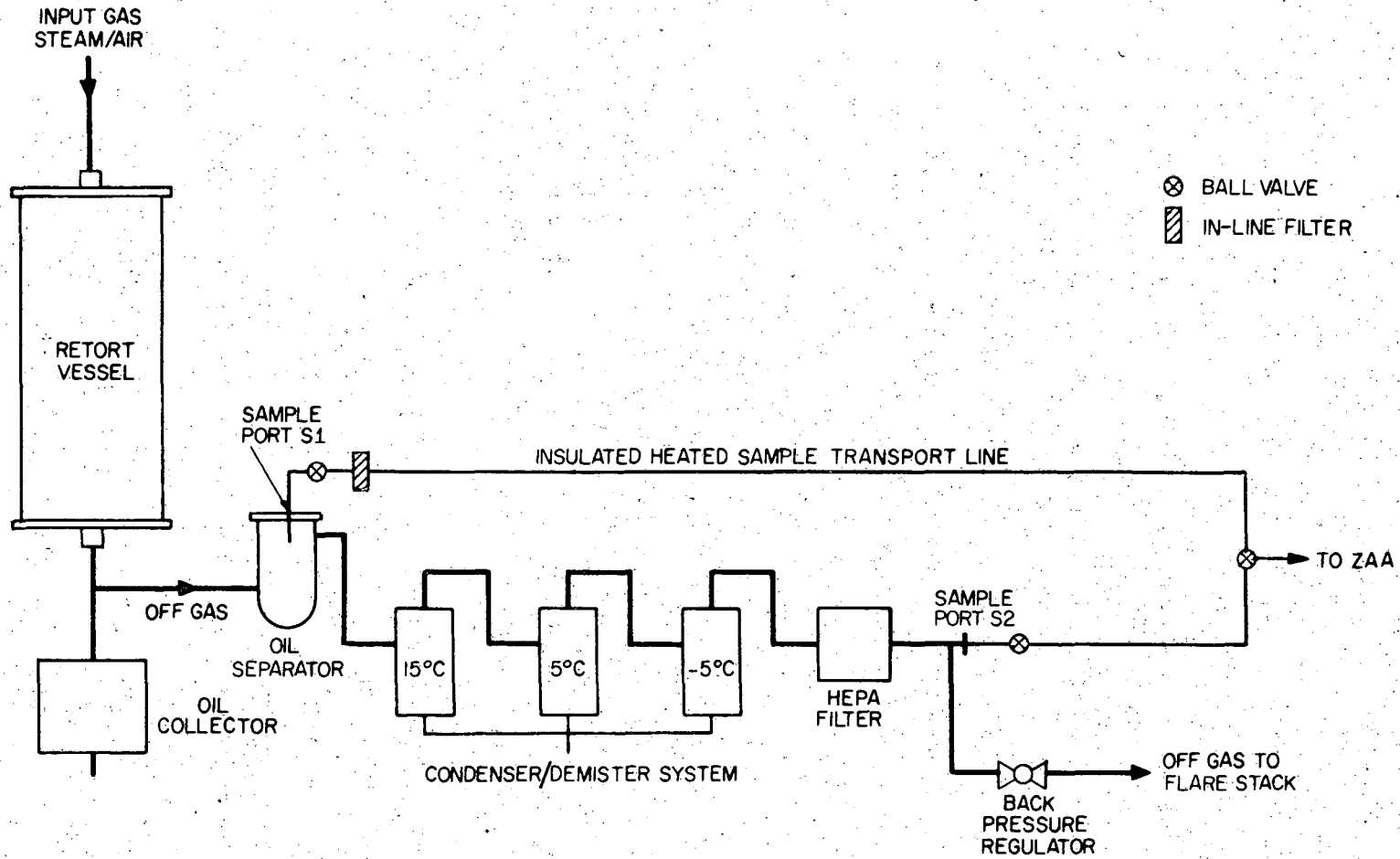

XBL 802-8228

Fig. 1. Sampling locations S1 and S2 for ZAA mercury analysis during retort run L-3.

to entering the condenser system and HEPA filter assembly. Sample port S1 was located on the top of the oil separator, and sample port S2 was located downstream of the HEPA filter. The intervening condenser system is a series of demisters and heat exchangers, designed to remove 98% of the entrained oil mist and water.

The sample probe used at port S1 consisted of a 9.4 mm (3/8 in) OD stainless steel (SS) tube which was inserted through the top of the oil separator a distance of 0.3 meter into the separator chamber. No provision for electrically heating the probe was made since the probe was heated by the hot offgas which is approximately 150°C at this point. A SS ball valve and in-line paper cartridge filter assembly were attached to the outlet of the probe. The filter prevented the large quantities of entrained oil from entering and possibly clogging the heated sample transport line. The choice of 9.4 mm OD SS tubing for the heated sample transport line has been previously described (Ref. 8). The line was thermally insulated with fiberglass sleeves, and its temperature was monitored with three attached thermocouples. This line ran 14 m to the instrument shack and terminated at a 3-way SS ball valve. The valve allowed sample gas from either port S1 or S2 to enter the mixer.

The temperature of the offgas at port S2 was equal to or slightly less than atmospheric temperature. Thus, provision was made to electrically heat the 50 cm long, 6.4 mm (1/4 in.) OD SS probe (Ref. 8) which was inserted coaxially into the 10 cm OD offgas line (Fig. 1). No in-line filter was necessary since most of the oil mist is removed by the condenser system. A 5.5 m section of insulated, heated sample transport line connected the S2 probe to the 3-way ball valve in the instrument shack. Three thermocouples, two on the transport line and one on the probe, were used to monitor line temperatures. A fourth thermocouple in the nose of the probe measured the offgas temperature.

The portion of the sample gas system which was located in the instrument shack is shown in Fig. 2. Calibration and dilution gas and O<sub>2</sub> were added to the sample gas stream just ahead of the mixer (Ref. 8). A 3-way SS ball valve was located downstream of the mixer to divert gas for bubbler train sampling. Several thermocouples were placed on the mixer and adjacent plumbing.

The cooling coil and rotary vane vacuum pump located downstream from the ZAA furnace were not used for the L-3 experiment. However, an in-line filter was placed between the ZAA furnace and the flow controller to prevent the flow controller from clogging. The pump was eliminated since the retort was operated at a constant positive backpressure of 3 psig, which was assumed to be adequate to deliver the desired volumetric flow rate through the plumbing system.

An 11 kilowatt AC power supply was used to alternately heat sample line S1 or S2, and separate 500 watt AC power supplies were used to heat probe S2 and the mixer assembly. Cool spots (temperatures less than 200°C) in the plumbing system between the furnace and the 3-way valve joining lines S1 and S2 and the furnace were eliminated by using additional 500 watt power supplies to pass more current through these points.

SCHEMATIC GAS HANDLING SYSTEM USED FOR L-3

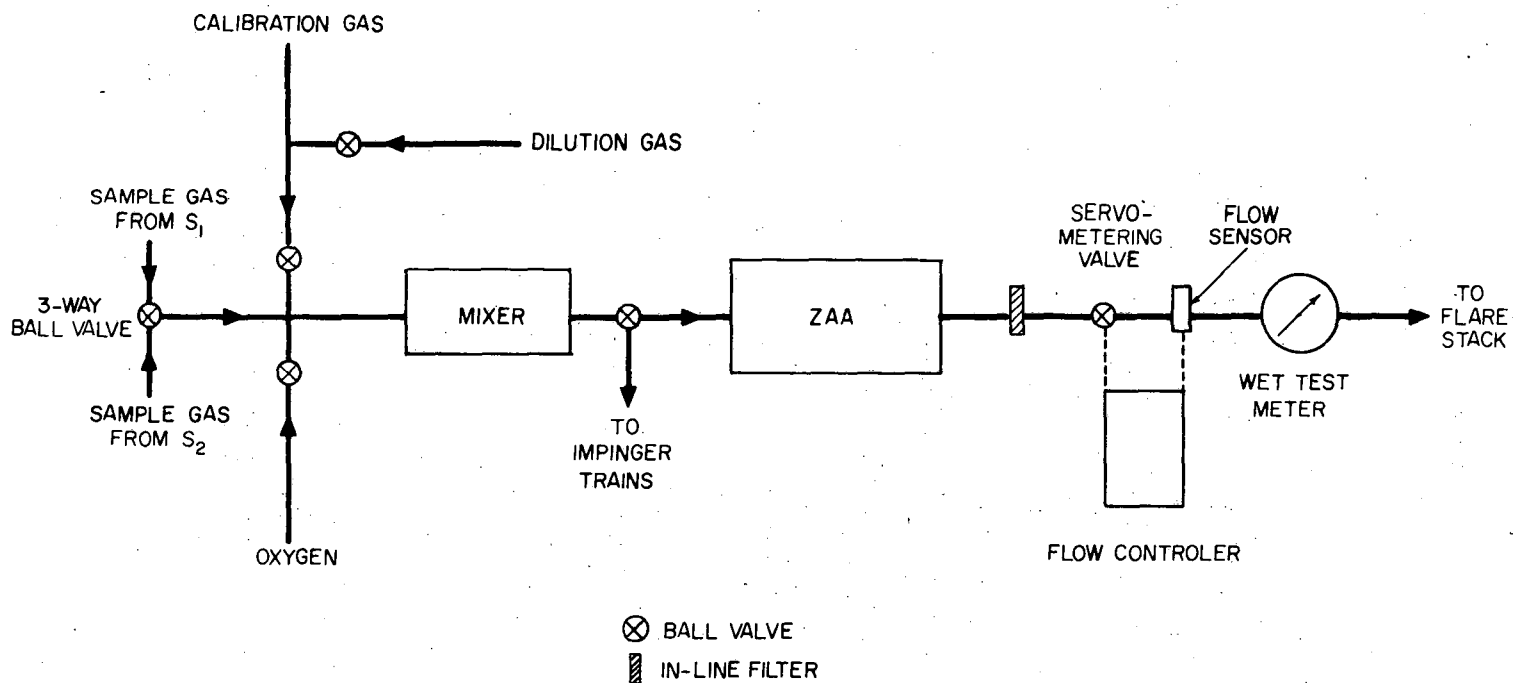

XBL 802-8240

Fig. 2. Gas handling system for on-line analysis of mercury in L-3 offgas.

Thermocouples from the sample probe, transport line, mixer, calibration device, ZAA furnace, and light source were connected to a Doric, Model 230A, programmable data logger. Flow controller, ZAA photomultiplier (PMT), and lock-in amplifier (LIA) voltages were also read by the data logger. The data logger was programmed to display selected data points and to print out all of the data points at regular time intervals.

Description of the ICl Bubblers. An attempt was made to collect Hg in the offgas in an acidic iodine monochloride (ICl) solution as a check on the accuracy of the ZAA monitor. Three 250 mL gas bubblers fitted with extra coarse frits were connected in series and placed in an ice bath. Each bubbler contained 100 mL of 1.0 M ICl solution made up in 1:1 HCl. A fourth 250 mL gas bubbler containing 100 g of indicating silica gel was placed in series after the ICl bubblers (Ref. 9). A wet test meter, protected by an acid trap, was connected downstream of the bubblers and was used to measure volumetric flow through the bubbler train. Mercury concentrations in the ICl solution were determined by direct injection of the liquid into a batch type ZAA spectrometer. Blank Hg concentration in the ICl solution was less than 50 ppb.

Recovery experiments were conducted in the laboratory prior to the retort run in order to determine the extraction efficiency of the ICl bubblers for inorganic Hg vapors produced by the calibration unit. Recovery was quantitative with approximately 90% of the Hg appearing in the first bubbler and the remainder in the second bubbler.

System Evaluation - Mechanical Components. In general, the heated sample transport line, the mixer, the calibration device, the furnace, and the flow controller functioned properly during the L-3 retort experiment. However, the need for a number of minor modifications and improvements became apparent. These are briefly discussed below.

When the ZAA was first brought on-line, the alonized 321 SS furnace was operated at a temperature of 950°C, and the offgas contained approximately 2% H<sub>2</sub>S by volume. Thus, highly corrosive conditions existed in the furnace, and after 3 hours of operation an 8 cm. section of the combustion chamber, which normally runs at high temperature, melted. Due to the high temperature and the high concentration of H<sub>2</sub>S, eutectic slagging of the tube undoubtedly played a significant role in this failure. However, metallographic examinations of the slag and furnace are being conducted to provide additional information regarding the nature of the failure.

A new alonized furnace was installed and was operated at temperatures ranging from 650 to 800°C. The ability of the ZAA to measure Hg in the off-gas stream was not impaired by these lower temperatures, and corrosion of the furnace was apparently reduced. After 40 hours of operation with H<sub>2</sub>S concentrations ranging from 1% to 2.5% by volume, the furnace had no visual signs of significant corrosive attack. It is likely that the furnace would have lasted two to three more days under these conditions. Metallographic examination of the furnace is being conducted in order to obtain a quantitative evaluation of furnace lifetime.



Two relatively minor furnace problems were encountered during the experiment. First, a 30% decrease in the volumetric flow rate of the offgas through the system occurred during the first 2.5 hours of operation. The source of this problem turned out to be the accumulation of scale in the small diameter (2 mm ID) tubing and fittings which served as the exit ports for the hot gases leaving the furnace. Substitution of larger diameter tubing and fittings eliminated this problem. Second, a thin film intermittently formed on the inner surfaces of the quartz windows at the ends of the adsorption chamber. This film absorbed UV radiation and significantly attenuated the PMT signal. The film was dealt with by repeatedly cleaning the windows with alcohol and lens tissue which restored the PMT signal to normal. Since the film was probably due to the condensation of hot vapors onto the relatively cool quartz (130 -160 °C), the window mountings will be redesigned to minimize the distance between the quartz and the SS supports used to electrically heat the furnace. This modification should increase the temperature of the windows to approximately 300 °C and eliminate the condensation problem.

Soon after the experiment began, the flow sensor and servometering valve for the flow controller clogged. They were removed, cleaned and replaced; and an in-line, paper cartridge filter was installed between the furnace and flow sensor to prevent further blockage. The corrosive nature of the offgas altered the thermal characteristics of the flow sensor. Thus, the system had to be recalibrated using a wet test meter (WTM). After recalibration, the flow controller functioned normally. However, the WTM was used exclusively for flow measurements during the remainder of the experiment since the relatively large pressure drop across the servometering valve limited the maximum volumetric flow through the system. Calibrations of the WTM before and after the experiment agreed within 1% and showed that the accuracy of the WTM was not affected by the offgas.

The pressure differential,  $\Delta P$ , forcing sample gas through the ZAA was provided by the retort which was maintained at 3 psi back pressure. With  $\Delta P$  equal to 3 psi, the maximum volumetric flow rate through the gas handling system was 2500 scc/min. With the servometering valve removed, the maximum flow rate was 3500 scc/min. The flow limitation did not create serious problems during the experiments; however, an in-line vacuum pump will be used to increase  $\Delta P$  in the future. The increased flow rate capacity will allow us to use the flow controller and will increase the flexibility of the system.

Several other minor modifications are being made to improve the system and to avoid potential problems in future experiments. These modifications include redesign of the seals on the heated sample probe, redesign of the plumbing system to eliminate "cool" spots, and installation of a check valve between the calibration system and the heated sample line. The check valve is needed to prevent H<sub>2</sub>S in the sample gas stream from entering the calibration system and forming HgS in the reservoir used to generate the saturated stream of mercury vapor.

System Evaluation - Instrumental Components. The on-line ZAA gas monitor functioned exceptionally well during the L-3 experiment. Mercury concentrations as low as 10 ppb were measured with as much as 85% extinction of the analytical line due to broadband UV absorption. The ability of the ZAA to function at such levels of extinction is due to the effectiveness of the ZAA

background correction method. Conventional AAS techniques, on the other hand, would be precluded under these conditions.

The ZAA photomultiplier tube (PMT) signal voltage is proportional to the sum of the transmitted intensity of the 253.7 nm mercury analytical line ( $\pi$ ) and the background correction lines ( $\sigma\pm$ ). Percent extinction of the analytical line due to broadband UV absorption is defined as the ratio ( $\times 100$ ) of the PMT signal voltage for sample (retort) gas to the signal voltage for zero gas (air). During the course of the L-3 experiment, extinction of the analytical line due to the broadband absorption typically exceeded 70%. With 80% extinction, the detection limit was 5 ppb and the coefficients of variation for five replicate measurements at 10 ppb and 50 ppb were 50% and 10%, respectively.

Throughout most of the experiment, the PMT signal was recorded using one pen of a dual-pen strip chart recorder. The second pen recorded the lock-in amplifier (LIA) signal which is proportional to the mercury density. Typical examples of PMT and LIA signals for zero and sample gases are shown in Fig. 3. For the zero gas, the PMT signal is at a maximum and the LIA signal defines the baseline. When the system is switched to sample gas, the PMT signal drops by an amount which is proportional to the broadband extinction, and the LIA signal increases in proportion to the mercury concentration. Typical reproducibility of the signals when switching between zero and sample gas is shown in Fig. 3. The 2.5 to 3 minute period oscillation in the LIA mercury signal for sample gas is not an instrumental effect and is discussed in Experimental Results.

Offgas matrix effects precluded calibration of the instrument by simply injecting the calibration gas into a stream of zero gas as described previously (Ref. 6,7). Instead, the method of standard additions was used to determine the concentration of mercury in L-3 offgas. With this method, calibration gas of varying mercury concentrations was injected directly into the sample gas. Typical standard additions curves are shown in Figs. 4a and b. Standard addition curves like these were used as calibration curves for subsequent measurements after corrections were made for the dilution effect of the calibration gas. A given calibration curve was used as long as the gas composition, extinction, furnace temperature, and sample gas flow rates remained relatively constant. Generally, new curves were constructed every two hours, or more often if conditions changed. The linear working range of the standard additions curves extended up to 125 ppb which coincides with earlier results obtained for zero gas calibration (Ref. 8).

It was originally thought that the analysis of the offgas obtained at sample port S1, ahead of the condenser train, would be difficult due to potential clogging of the sample line, mixer, and furnace with entrained oil. Further, it was anticipated that smoke from the incomplete combustion of oil might totally extinguish the analytical line. Since we assumed that these problems would be much less severe when sampling from port S2, we started sampling at S2 and continued until the instrumental evaluation was completed. As a result, sampling at S1 did not begin until late in the experiment, after 21 hours of sampling at S2.

TYPICAL PMT AND LIA SIGNALS FOR SAMPLE GAS AND ZERO (BASELINE) GAS

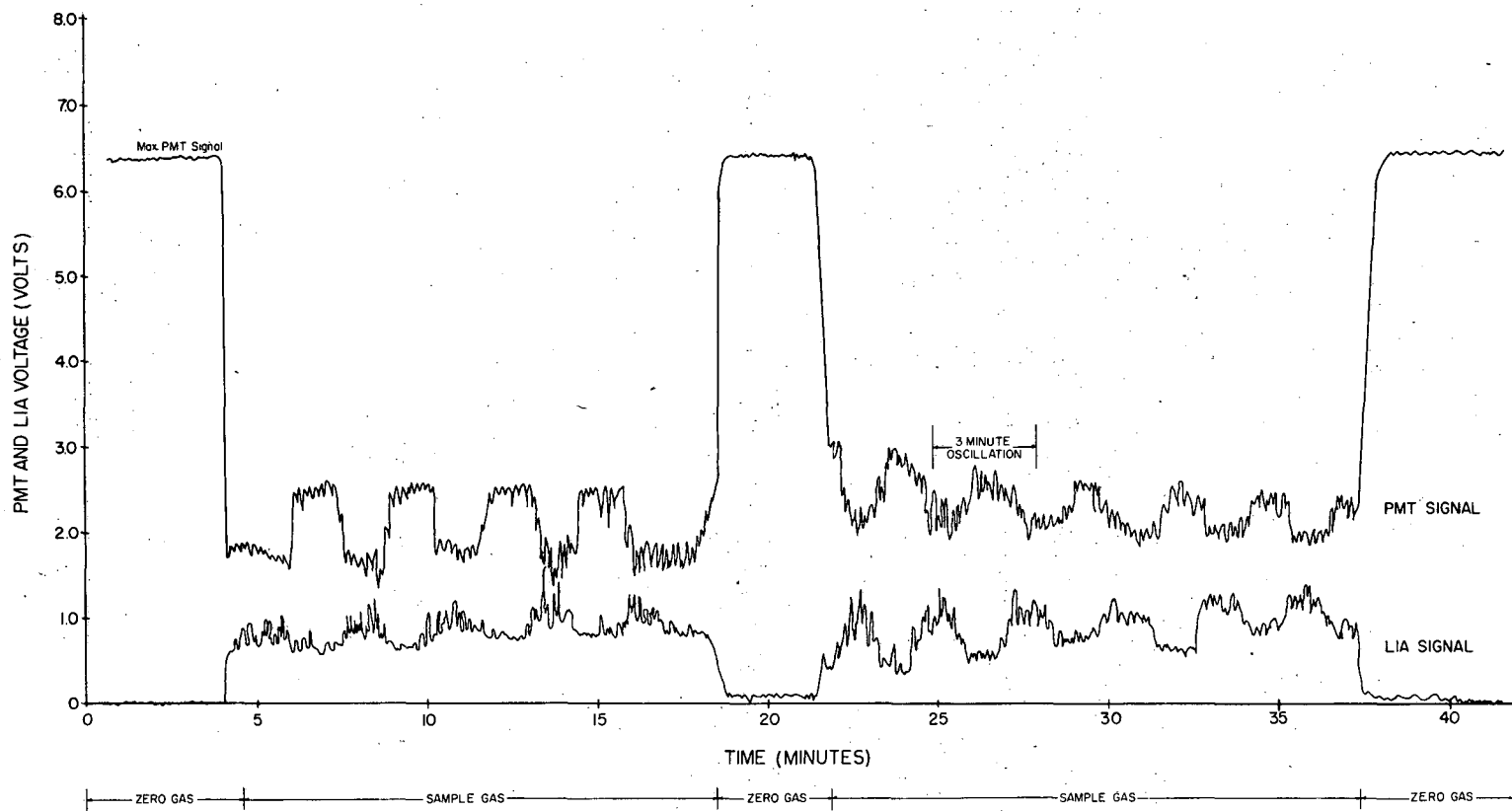

XBL 802-8237

Fig. 3. Photomultiplier (PMT) and lock-in amplifier (LIA) signals for sample gas (offgas) and zero gas (air). The zero gas establishes LIA baseline and the maximum PMT signal. Note the 3 minute oscillation in both signals and the fact that they are 180° out of phase.

STANDARD ADDITION CURVE FOR OFFGAS SAMPLED  
AT S2 ON MAY 11

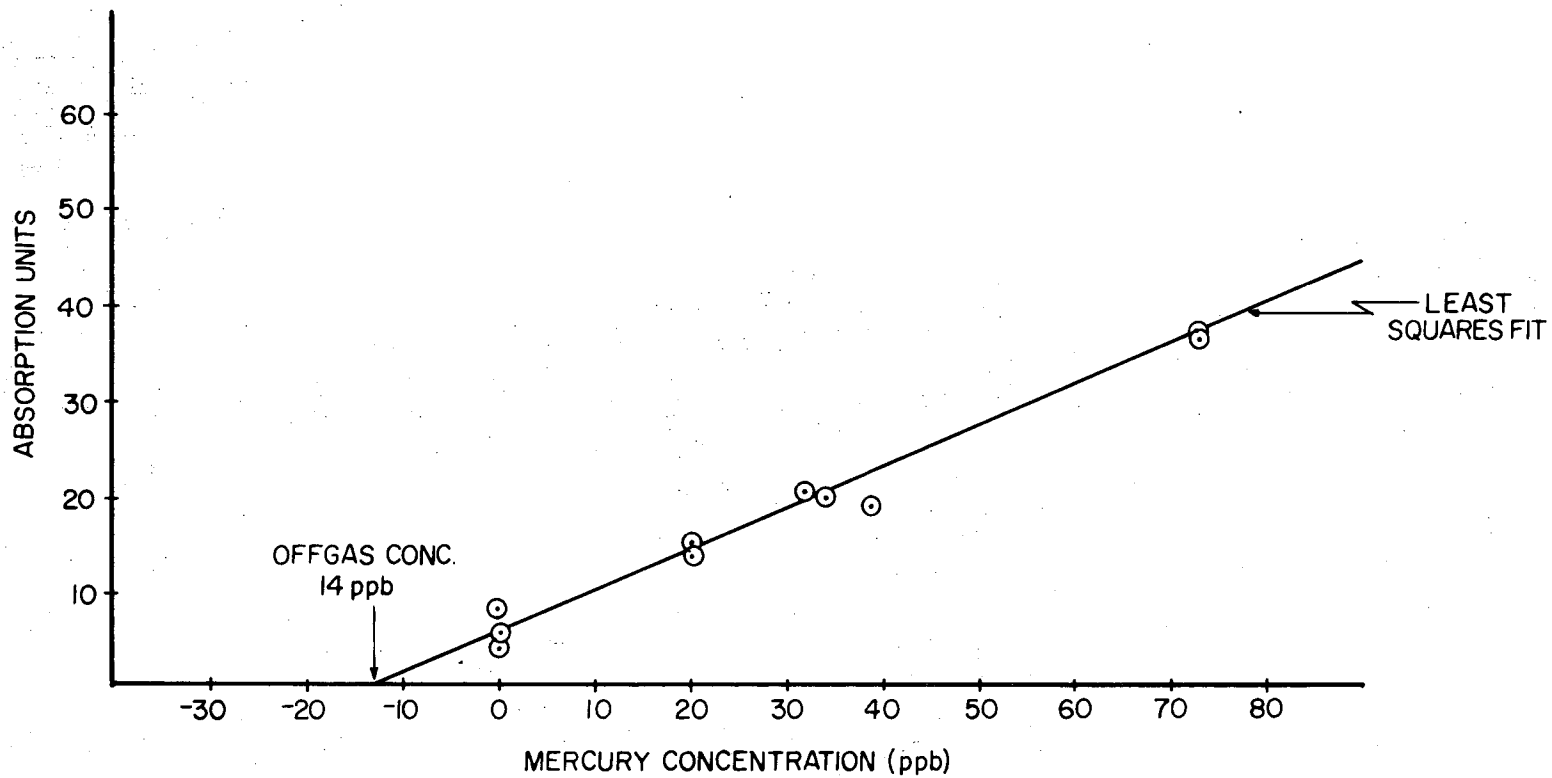

15

XBL 802-8242

Fig. 4a. Least square fit to standard additions data for offgas from sample point S2.

STANDARD ADDITION CURVE FOR OFFGAS SAMPLED  
AT S1 ON MAY 12

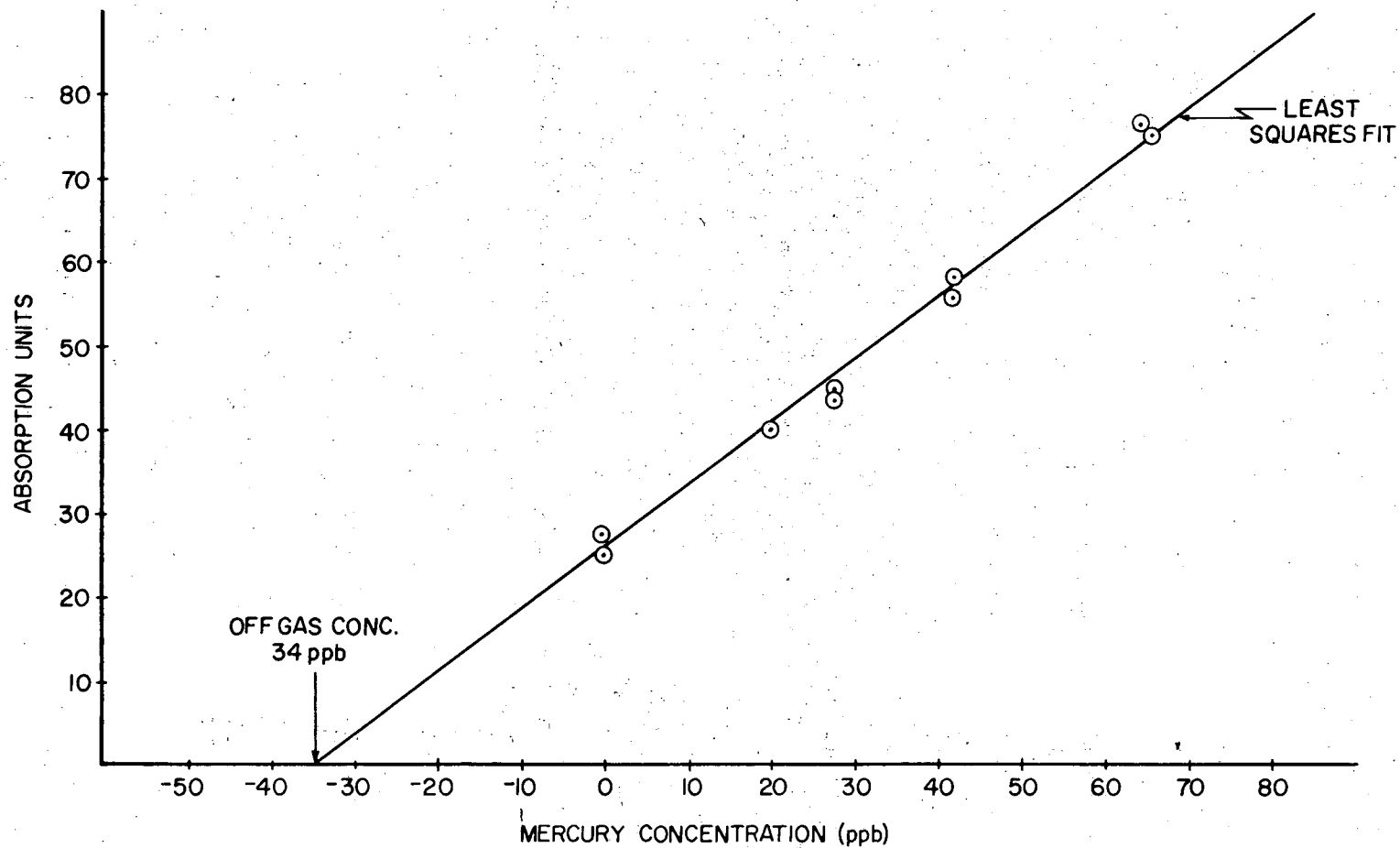

Fig. 4b. Same as Fig. 4a except offgas from S1.

XBL 802-8239

Our initial apprehensions about the problems associated with entrained oil proved to be unfounded. No evidence of clogging was observed during the four hours of sampling at S1. In addition, the magnitude of UV extinction due to smoke was not appreciably greater than the extinction observed with offgas from S2. Instrumental sensitivities and accuracies were nearly identical for offgas from both locations.

Temperature control for the ZAA light source proved to be inadequate during the L-3 experiment. In order to prevent baseline drift, the light source must be maintained at a constant temperature (Refs. 7, 8). Temperature stability was to be achieved by circulating either compressed air or water from LLL's closed-loop cooling-water system through the jacket surrounding the light source. However, unusually hot weather during the last two days of the experiment pushed the temperature in the instrument shack over 40°C. As a result, the cooling capacity of the water system was exceeded, and the temperature of the light source drifted up to a maximum of 44°C during the day.

On the two hot days, instrumental baseline drift was linear and on the order of 20 ppb per hour during the diurnal warming and cooling periods. To compensate for this drift, it was necessary to switch from sample gas to zero gas, rezero the instrument, and switch back to sample gas every 20 to 30 minutes. In future experiments, baseline drift will be controlled with a compact, refrigerated, circulation bath. This closed circuit water bath, which is currently being built, should maintain the light source at a constant  $25.0 \pm 0.5$  C, even at atmospheric temperatures up to 35°C.

When the temperature in the instrument shack exceeded 35°C, we had to "retune" the ZAA electronics. Retuning was necessary because thermal expansion of the pulse transformer core and the mounting blocks which support the quartz slab in the variable phase retardation plate (VPRP) produced an additional DC stress on the quartz. The additional stress resulted in asynchronous switching between the  $\pi$  and the  $\sigma_{\pm}$  beams. Retuning of the instrument consisted of reduction of the DC and AC currents driving the VPRP and adjustment of the LIA frequency and phase controls.

During the last several hours of the L-3 experiment, the temperature in the instrument shack reached 42°C and the temperature in the ZAA housing exceeded 46°C. At these temperatures, we were unable to maintain synchronous switching between the  $\pi$  and  $\sigma_{\pm}$  beams and were forced to discontinue sampling. This type of instrument failure can be prevented in future field experiments during potentially hot weather by installing air conditioning in the instrument shack.

Experimental Results - ZAA Hg Gas Monitor. ZAA Hg monitoring was initiated on May 9, 28 hours after ignition of the retort. During the subsequent 72 hours of the retort run, a total of 25 hours of quantitative Hg data were obtained. Offgas Hg concentrations are plotted in Fig. 5 as a function of time after ignition. The data shown in the figure are one-half hour time averages. Time averages which were less than or equal to 10 ppb are plotted at the 10 ppb level. Analytical precisions, as determined by the coefficient of variation, are not shown in the figure but were approximately  $\pm 5$  ppb for all data.

CONCENTRATION OF MERCURY IN L-3 OFFGAS SAMPLED  
AT SAMPLE PORTS S1 AND S2

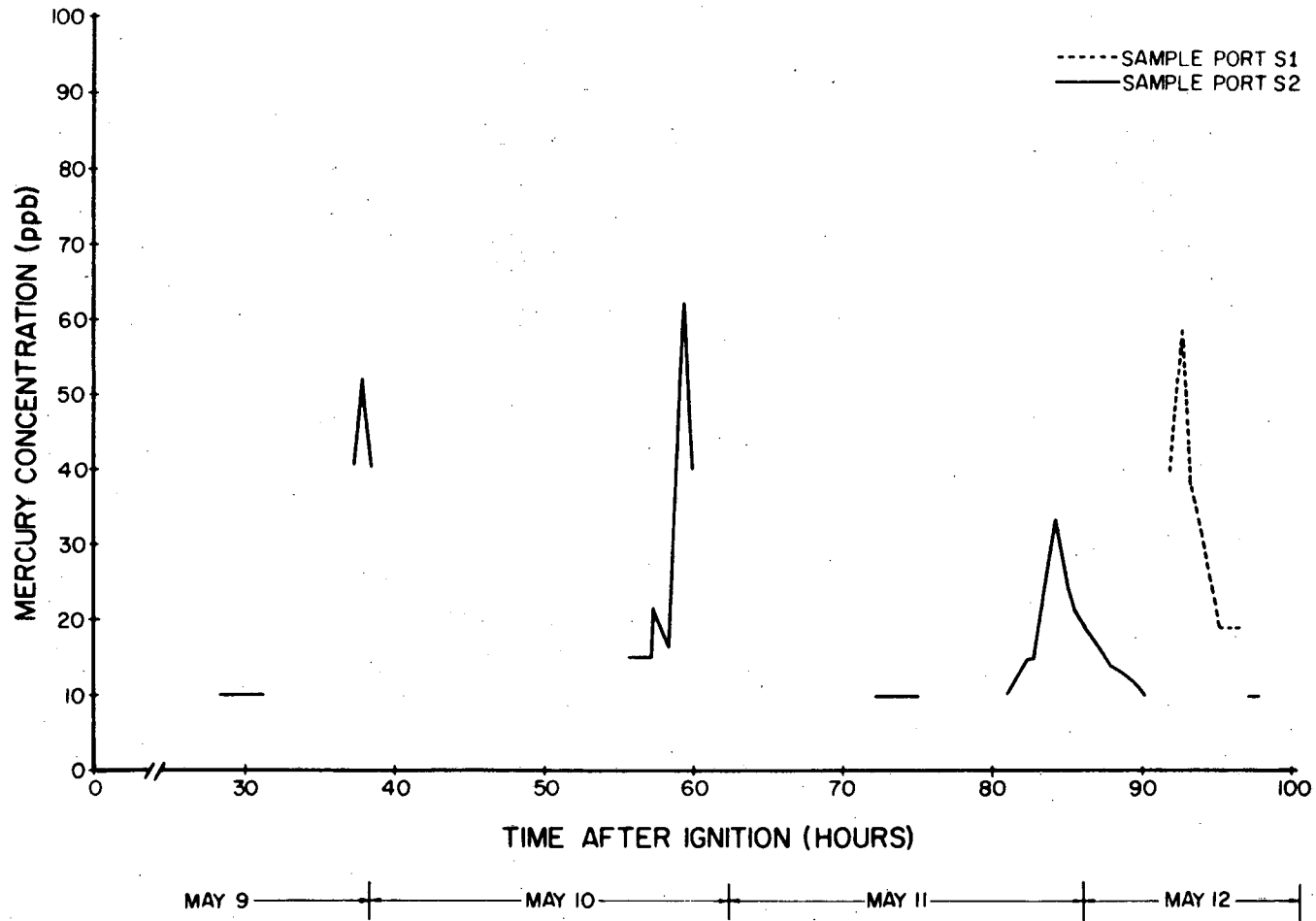

XBL 802-8241

Fig. 5. Mercury concentration in L-3 offgas at S1 and S2 as a function of time after retort ignition.

Evaluation of the ZAA was the primary objective during the first 50 hours of the retort run. Consequently, adjustments and modifications to the system limited the collection of Hg data during this period. Data were also not collected between midnight and 8 a.m. except on the morning of May 12. All data obtained from May 9 through May 11 were for offgas sampled at port S2, downstream of condenser system. Sampling was initiated at port S1, ahead of the condenser system, on the morning of May 12 and continued for four hours. Then, sampling was switched back to S2 for one hour until excessive temperatures resulted in instrument failure.

Mercury concentrations in L-3 offgas ranged from less than 5 ppb to a maximum of 62 ppb (Fig. 5). Since the concentrations were quite low and often within a few standard deviations of the detection limit, there are few statistically significant distinctions among the data. However, the peaks observed on May 10 and 12 are significantly different from the baseline value of 10 ppb ( $p < 0.01$ ). The maximum observed rate of change in Hg concentration (May 10) was 30 ppb Hg per hour.

The data obtained from the L-3 retort run can be compared to the ZAA data collected during the LETC controlled-state retort run CS-69 (Ref. 5). Retort offgas from run CS-69 was continuously monitored for Hg with a prototype ZAA. Mercury concentrations were less than 10 ppb for the first 66% of that run. In the latter portion of the run, concentrations ranged up to 8 ppm. Large temporal variations in concentration were observed which were similar to the variations recorded in L-3 offgas.

The switch from sample port S2 to port S1 on May 12 took one hour. When sampling at S2 was stopped, Hg concentration downstream of the condensers was  $\leq 10$  ppb; when sampling was resumed, concentration ahead of the condensers was 40 ppb. This concentration increase cannot necessarily be attributed to Hg removal in the condenser system since there was a one hour delay and Hg concentrations can change rapidly. In future experiments, sample port switching can be made more rapidly, and the Hg removal efficiency of condensers and demisters can then be evaluated.

A continuous oscillation with a period of 2-1/2 to 3 minutes was observed in the LIA Hg signal when sampling was conducted at port S2 (Fig. 3). The oscillation was not an artifact associated with the ZAA since it did not occur when air and Hg calibration gas were passed through the instrument. The oscillation also did not occur when sampling at S1; this suggests that the oscillation may be associated with the condenser train. If this is true, the period of oscillation may be related to the residence time of the offgas in the oil separator, condensers, and demisters. These units have a combined volume of 420 L. With a typical offgas flowrate of 200 L/min, the residence time of offgas in the condenser system is 2.1 minutes which is close to the observed period of oscillation.

It has been hypothesized that Hg originally present in raw oil shale is volatilized by the approaching pyrolysis front, is swept ahead of the front by the offgas, and then condenses on a layer of cool raw oil shale (Ref. 5). If this process continues as the front propagates down the retort bed, Hg eventually becomes concentrated in the lowest layer of the raw shale. When this layer is finally heated, a large pulse of Hg appears in the offgas.



This pulse would, therefore, not be observed if the retorting process was terminated prior to the heating of the lowest layer.

A likely reason why Hg concentrations in L-3 offgas were relatively low, even toward the end of the run, is that the run was terminated before the lower one meter of the shale column was retorted. In addition, Hg measurements were stopped four hours before that, due to excessive temperatures in the instrument shack. Thus, it is possible that offgas Hg concentrations may actually have increased during the final four hours. Shale samples have been obtained at one foot intervals from the L-3 shale column. These will be analyzed for mercury to determine if the one meter layer of unretorted shale is enriched with mercury relative to the upper retorted layers and the raw shale used for the run.

Experimental Results - ICl Bubblers. On May 11, 76 hours after the start of the run, the ICl bubbler train was brought on-line. Upon initiation of the offgas flow, the first bubbler solution turned orange then brown. A dark brown film formed on the surface of the solution; then the solution turned milky white. Flow was stopped when the third bubbler solution turned brown, as this color change indicates that free iodine has been liberated and the solution is depleted. Total volume of offgas passed through the bubbler train was only 11 liters. Bubbler solutions were emptied into separate containers. The empty bubblers and connecting lines were rinsed with methyl iso-butyl ketone (MIBK) to remove the organic deposits which had formed on the surfaces. These rinses were also separately collected. Both the MIBK and ICl solutions were analyzed for Hg by ZAA as previously described. As expected, Hg concentrations in these samples did not exceed blank concentrations. Offgas Hg was not detected by this method because the ICl solution became depleted before a sufficient volume of offgas could be passed through the bubblers.

### Task 3. Design and Construction of Experimental Apparatus

General Description. The laboratory scale oil shale retort is designed to batch process 6 kg of raw shale at temperatures up to 1200°C. Oil and water are removed from the retort offgas by a series of variable temperature condensers. Provision has been made for monitoring of the offgas at several locations before, within, and after the condenser system. Electrical, mechanical, and fluid systems have been tested; however, no shale has been retorted to date. A schematic of the retort is presented in Fig. 6, and an overall photographic view is presented in Fig. 7. Photographic details are shown in Figs. 8-10.

Retort Vessel and Furnace. The retort vessel (Figs. 6, 8) is a mullite (ceramic) tube, 10.2 cm OD by 8.9 cm ID by 162 cm long. The ends of the tube have been ground flat to accept 316 SS flanges (Fig. 9) which butt seal with viton O-rings. Each flange has a channel located beneath the O-ring seat through which cooling water is circulated. An inner mullite tube, 7.6 cm OD by 7.0 cm ID by 40.6 cm long, supports a ceramic grate which holds the shale column in the heated zone of the furnace. The retort vessel extends 40 cm above and below the shale column which is approximately 82 cm long. This extension positions the flanges 20 cm away from the ends of the furnace housing.

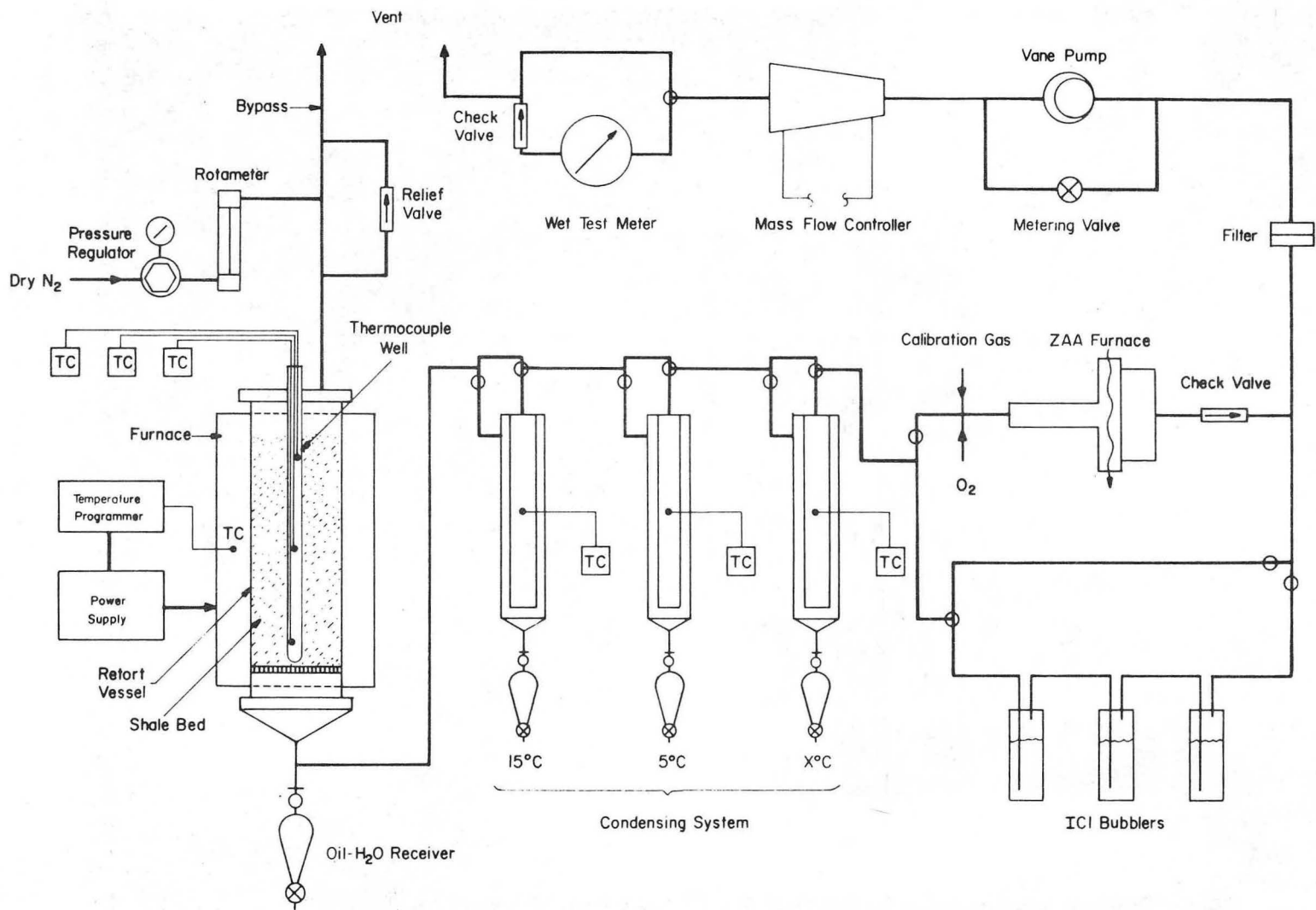

XBL 802-8374

Fig. 6. Schematic of 6 kg laboratory retort and associated gas handling system.

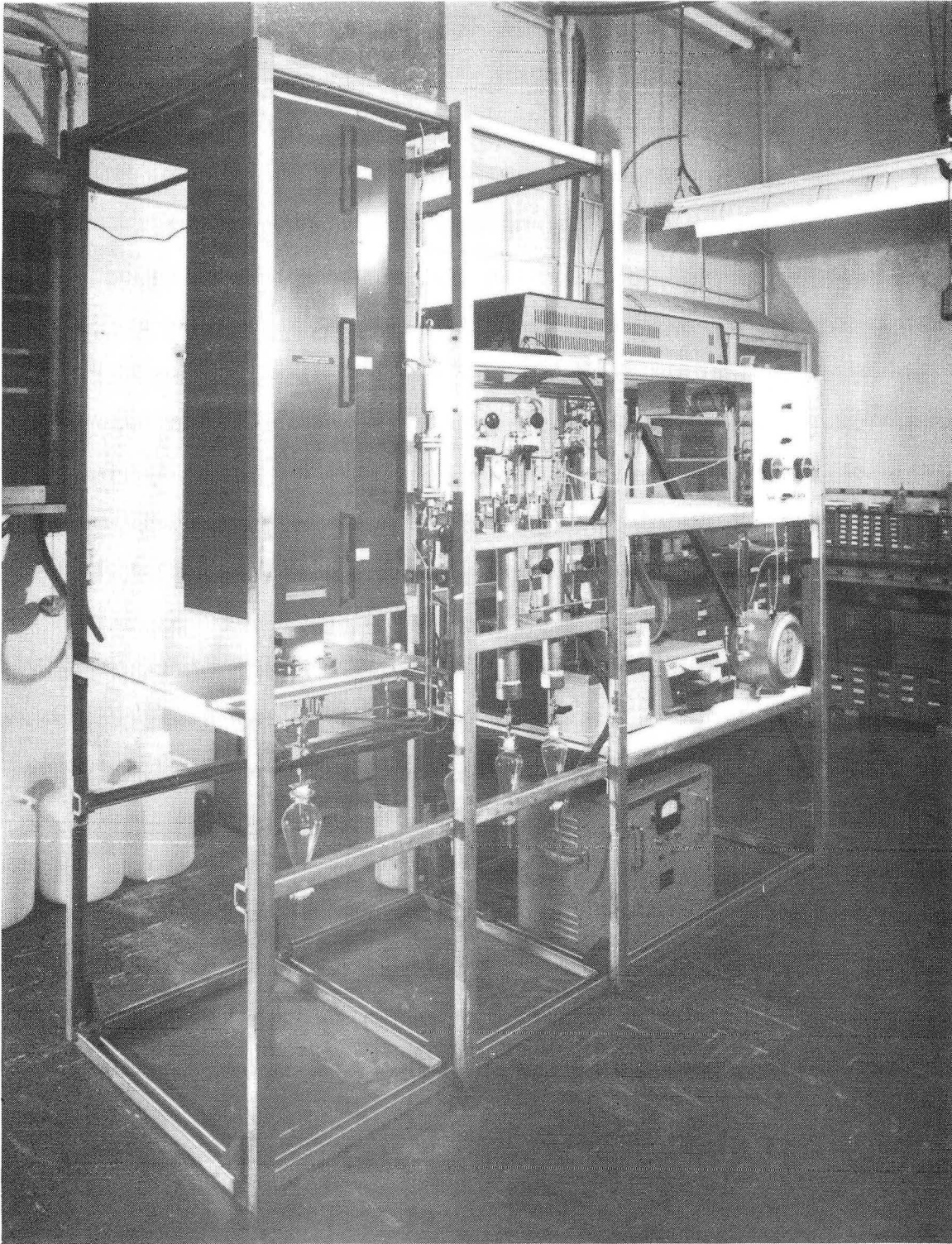

XBB 798-10748

Fig. 7. Overall photographic view of 6 kg laboratory retort.

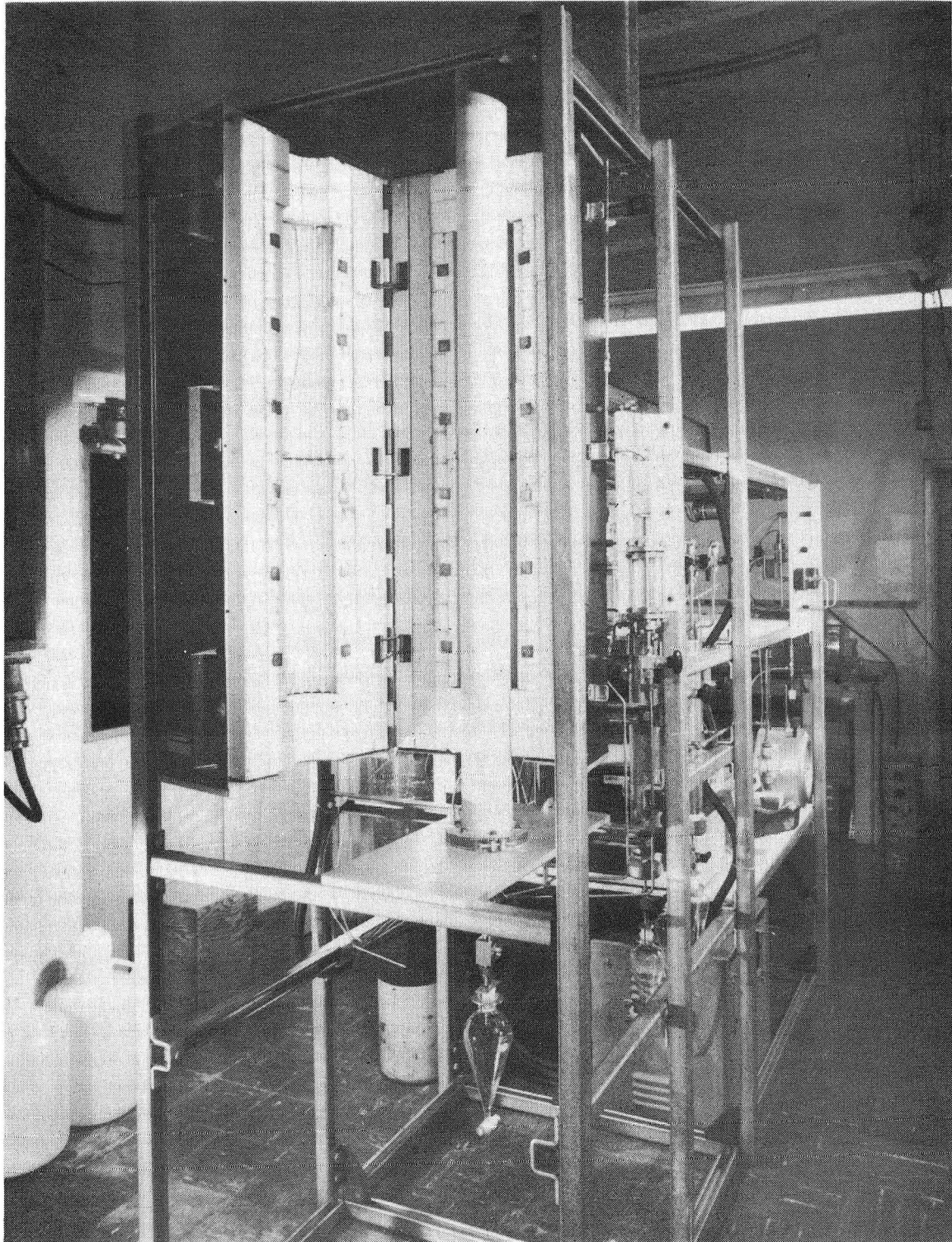

XBB 798-10750

Fig. 8. Photographic detail of 6 kg laboratory retort showing furnace and mullite retort vessel.

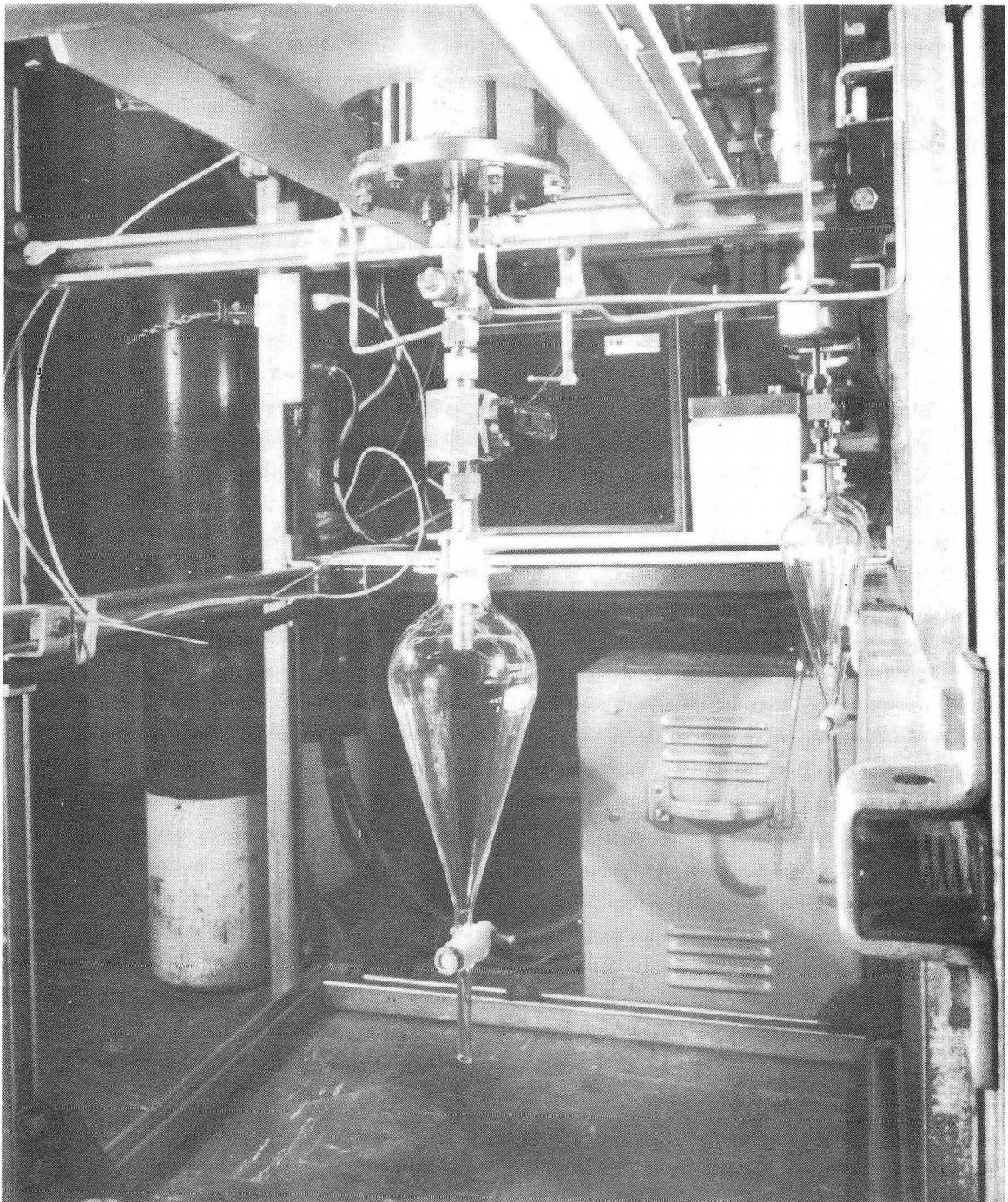

XBB 798-10749

Fig. 9. Photographic detail of 6 kg laboratory retort showing bottom flange on retort vessel and ambient temperature oil and water receiver.

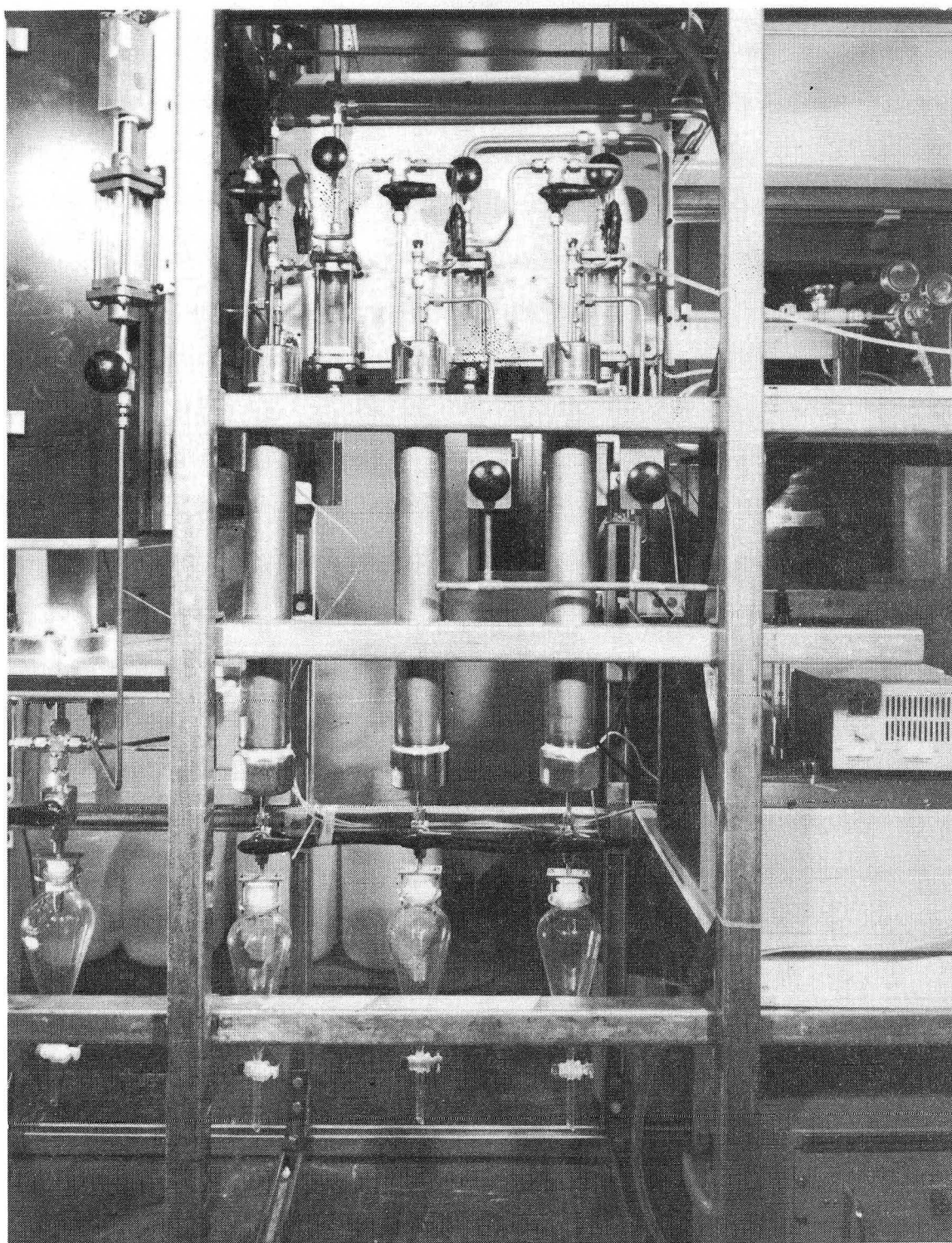

XBL 798-10747

Fig. 10. Photographic detail of 6 kg laboratory retort showing the variable temperature condenser system.

The retort vessel is heated by a Lindberg, Model 54572, single zone tube furnace designed for a 1200°C maximum operating temperature. The heated zone is 91.4 cm long, and the overall length of the housing is 122 cm. Temperature control is provided by a Lindberg, Model 59554, control console equipped with the half-cycle temperature programmer option, Model 59972. The programmer provides heating or cooling ramping at the rate of 0.4 to 9.9°C per minute over the calibration range of the control console. Electrical power for the furnace is regulated at 230 VAC.

A mullite tube, closed on one end, serves as a thermocouple well. This tube, which is 1.1 cm OD by 0.8 cm ID by 132 cm long, enters the retort vessel through the top flange and extends down through the shale column (Fig. 6). Thermocouple junctions are positioned in the well at the center of the shale column and 10 cm from both ends of the column.

Condensing System. Oil and water which drain from the retort vessel are collected in an ambient room temperature receiver located immediately below the retort (Figs. 6, 9). This receiver is a pyrex separatory funnel joined to the 1.3 cm OD, 316 SS, exit tubing with a teflon stopper fitted with a viton O-ring to seal the stopper to the tubing. Offgas exits the retort and passes through a section of electrically heated 0.6 cm OD, 316 SS tubing, to the condenser system (Figs. 6, 10). The condensers are constructed of 312 SS pipe, 5.1 cm OD by 46 cm long. Cooling fluid is passed through approximately 2 m of 0.6 cm OD SS tubing wound inside each condenser. The first condenser is maintained at 15°C, the lowest temperature obtainable with the building's closed-circuit water system. The temperatures of the second and third condensers are controlled by a Brinkmann Lauda K-2/R constant temperature circulating bath which is capable of regulating at -5°C. Optimum temperatures for the last two condensers will be determined experimentally. Temperatures of the exit gas from all three condensers are monitored with thermocouples. The plumbing system connecting the condensers is designed so that offgas can be routed past any or all of the three units in order to facilitate sampling at various points in the retort system.

ZAA and Bubblers. The in-line ZAA gas monitor is to be installed downstream of the condenser system. During monitoring, the entire offgas stream will be passed through the ZAA furnace. Provision has also been made to alternately pass the offgas through a series of bubblers in order to chemically trap out the elements of interest. When the retort system is fully developed, two ZAA monitors will be simultaneously operated. This will necessitate the installation of at least one additional flow controller so that flow through each ZAA furnace can be controlled and monitored.

Gas Handling System. The gas handling system for the laboratory retort (Fig. 6) is essentially the same as the system described in an earlier report for the first field test of the gas monitor (Ref. 6). In its present configuration, the retort will be operated exclusively with an inert atmosphere of N<sub>2</sub>; however, provision can be made in the future for use of an air-steam retorting atmosphere. Flow is initially regulated with a rotameter and needle valve. A rotary vane vacuum pump located downstream of the ZAA furnace may be needed to maintain the required pressure drop through the system. The flow rate of offgas is regulated and monitored by the mass flow controller which will be periodically calibrated with a WTM as the composition of the offgas changes.

Data Acquisition. Temperatures in the furnace, retort vessel, condensers and gas lines are monitored with K-type thermocouples. Temperature readout is provided by a Doric, Model 230A, data logger which can display and print out data points at programmed intervals as well as average data over specified intervals. Voltage output from the flow controller can be displayed either on a digital voltmeter or on the data logger. The PMT and LIA voltage signals from the ZAA are recorded by a dual-pen strip chart recorder.

#### PROJECTED WORK

The projected work for the fourth quarter extending from July 1 to September 30, 1979 is as follows:

- Flameless AAS techniques for trace elemental analyses of shale oil will be evaluated. Preliminary tests suggest that oils can be analyzed by sufficiently diluting them in an organic solvent, such as xylene, and directly injecting them into the graphite furnace or by digesting them in acid followed by direct injection (Task 1).
- Analytical tests, using a discrete sample ZAA spectrometer, will be made to evaluate the performance of the new As and Cd lamps (Task 2).
- Several minor modifications and improvements, suggested by the Lawrence Livermore Laboratory retort experiment, will be made to the Hg ZAA spectrometer (Task 2).
- The 6 kg laboratory-scale retort will undergo preliminary tests. If the tests are successful, the first batch of shale will be retorted (Task 3).



## REFERENCES

1. Anonymous, "Analytical methods for atomic absorption spectroscopy using the MHS mercury/hydride system," Perkin-Elmer Manual 092-316 (October 1978).
2. Anonymous, "Methods for chemical analysis of water and wastes," U.S. Environmental Protection Agency Manual EPA-600/4-79-020 (March 1979).
3. J. P. Fox, D. S. Farrier, and R. E. Poulson, "Chemical characterization and analytical considerations for an in-situ oil shale process water, LETC/R7-78/7 (1978).
4. D. C. Girvin, A. T. Hodgson, and J. P. Fox, "Distribution of As, Cd, Hg, Pb, Sb and Se during simulated in-situ oil shale retorting: Quarterly Progress Report for October 1 - December 31, 1978," Lawrence Berkeley Laboratory Report UCID-8106 (January 1979).
5. J. P. Fox, J. J. Duvall, K. K. Mason, R. D. McLaughlin, T. C. Bartke, and R. E. Poulson, "Mercury emissions from a simulated in-situ oil shale retort," Lawrence Berkeley Laboratory Report LBL-7823 (July 1978).
6. D. C. Girvin and A. T. Hodgson, "Distribution of As, Cd, Hg, Pb, Sb, and Se during simulated in-situ oil shale retorting: Quarterly Progress Report for January 1 - March 31, 1979," Lawrence Berkeley Laboratory Report LBID-042 (April 1979).
7. D. C. Girvin, T. Hadeishi, and J. P. Fox, "Use of Zeeman atomic absorption spectroscopy for the measurement of mercury in oil shale gases," Lawrence Berkeley Laboratory Report LBL-8888 (March 1979).
8. D. C. Girvin and J. P. Fox, "On-line Zeeman atomic absorption spectroscopy for mercury analysis in oil shale gases: Final report," Lawrence Berkeley Laboratory Report LBL-9702 to Radian Corporation and U. S. Environmental Protection Agency (August 1979).
9. Code of Federal Regulations, Title 40-Protection of the Environment, Chapter 1, "National Emission Standards for Hazardous Air Pollutants, Appendix B, Test Methods 101 and 102," (Revised July 1, 1977).

This report was done with support from the Department of Energy. Any conclusions or opinions expressed in this report represent solely those of the author(s) and not necessarily those of The Regents of the University of California, the Lawrence Berkeley Laboratory or the Department of Energy.

Reference to a company or product name does not imply approval or recommendation of the product by the University of California or the U.S. Department of Energy to the exclusion of others that may be suitable.

TECHNICAL INFORMATION DEPARTMENT  
LAWRENCE BERKELEY LABORATORY  
UNIVERSITY OF CALIFORNIA  
BERKELEY, CALIFORNIA 94720