

UC Irvine

UC Irvine Previously Published Works

Title

The challenge of brain lipidomics

Permalink

<https://escholarship.org/uc/item/94396288>

Journal

Prostaglandins and Other Lipid Mediators, 77(1-4)

ISSN

1098-8823

Author

Piomelli, Daniele

Publication Date

2005-09-01

DOI

10.1016/j.prostaglandins.2004.09.006

Copyright Information

This work is made available under the terms of a Creative Commons Attribution License, available at <https://creativecommons.org/licenses/by/4.0/>

Peer reviewed



Review

The challenge of brain lipidomics

Daniele Piomelli*

*Department of Pharmacology, Center for the Neurobiology of Learning and Memory,
University of California, Irvine, CA 92697-4625, USA*

Received 30 August 2004; accepted 14 September 2004
Available online 28 November 2004

Abstract

After many years backstage, lipids have made a come back in the limelight of neuroscience. This renewed excitement was sparked by a series of convergent discoveries in the fields of neural development, synaptic physiology and receptor pharmacology, which have begun to reveal the roles played by lipid messengers and their receptors in brain function. Such roles extend from the development of the neocortex to the processing of complex behaviors, encompassing a territory as vast as those traditionally assigned to growth factors, neurotransmitters and neuropeptides. Along with these basic discoveries, technical advances have simplified the identification and quantification of neural lipids, achieving a degree of sensitivity and selectivity that was unthinkable only 10 years ago. Thanks to this progress, we can now resolve complex mixtures of lipid molecules and quantify each of their components, which are often present in tissues at vanishingly low concentrations. In this review, I outline several key features of brain lipid signaling and discuss the opportunities and challenges that such features impose on future lipidomic approaches.

© 2004 Elsevier Inc. All rights reserved.

Keywords: Brain lipidomics; Neuropeptides; Neocortex

Contents

1. Introduction	24
2. Some definitions	25

* Tel.: +1 949 824 6180; fax: +1 949 824 6305.

E-mail address: piomelli@uci.edu.

3. Unit permutation	25
4. Serial signalling	28
5. On-demand signaling	30
6. Local actors	31
7. Technical coda	32
Acknowledgments	33
References	33

1. Introduction

Learning for the first time about prose and verse, the uncouth Monsieur Jourdain – one of Molière’s most memorable characters – cries out in disbelief: “What! When I say ‘Nicole, bring me my slippers and my night-cap’, I am speaking in prose?” “Yes, Monsieur”, replies his teacher. “Oh my! – concludes Jourdain – I have been speaking in prose for more than 40 years without even knowing it!”.

Thinking about lipidomics, those of us who have studied lipids for some time cannot help but feel like the baffled Monsieur Jourdain: have we been doing lipidomics all along and did not know it? This question hides another, more serious problem: is lipidomics just an industrialized version of lipid biochemistry or is it a genuinely new discipline? Does it stem from real scientific needs and technological advances, as genomics does? In other words, does it truly deserve the ‘omics’ status?

Thirty years ago one of the great textbooks of biochemistry could curtly state that lipids, unlike nucleic acids and proteins, “do not have information-carrying function.” [1]. Today very few people would still stand by this statement: three decades of research on signal transduction and cell recognition have put that prejudice to rest. The doubt remains, however, as to whether lipids are on par with nucleic acids and proteins when it comes to the task of carrying information inside and outside the cell. That is, whether lipids can generate as broad an array of informational molecules as nucleic acids and proteins do. At first, a simple calculation seems to suggest a negative answer: if one multiplies the number of active genes in a mammalian genome by the number of potential post-translation modification for each gene product, the figure obtained is likely be much greater than the lipid complement of even the most complex cell. Nevertheless, when we give a closer look at the lipidome, and particularly at how the structural units that compose it can rearrange themselves in space and time, we are brought to conclude that lipids too have a bewildering signaling potential, even though they realize it in ways that are rather unique.

In this review, I outline what I consider as four defining features of lipid signaling: first, the generation of informational diversity through permutation of simple structural units; second, the pervasive use of ‘serial signaling’ – that is, the application of a single biochemical pathway to multiple signaling needs; third, the adoption of a signaling modality defined by the rapid, on-demand response to primary signaling events, such as receptor activation; and, last, the localized nature of lipid-mediated signaling. In no other mammalian tissue do such features emerge more clearly than in the brain, where the roles of lipid messengers extend from the development of the neocortex to the processing of behavior. It is in this highly

Table 1
Examples of Lipid classes

Name	Definition
Simple lipids	
Triacylglycerols	Glycerol ester in which 3 hydroxyl groups are esterified to fatty acids
Diacylglycerols	Glycerol ester in which 2 hydroxyl groups are esterified to fatty acids
Monoacylglycerols	Glycerol ester in which 1 hydroxyl group is esterified to fatty acid
Fatty acids	Long-chain organic acids different in length and unsaturation
Cholesterol	Most common animal sterol
Cholesteryl esters	Cholesterol esterified to fatty acid
Complex lipids	
Glycerophospholipids	Phospholipids containing glycerol esterified with one phosphate (sn-1) and one or two fatty acid residues (sn-2 and sn-3)
Sphingolipids	Phospholipids based on sphingoid bases (e.g., gangliosides)
Phosphonolipids	Phospholipids based on phosphonic acid (i.e., containing a carbon–phosphorus bond)

complex and heterogeneous organ that the need and the challenges of lipidomics are most apparent.

2. Some definitions

Before we turn to our first topic – the role of unit permutation in lipid signaling – it may be useful to define the term ‘lipid’ and to describe the basic components of this class of biomolecules. Surprisingly enough, this is not a straightforward task and perhaps a good way to start is by establishing what lipids are not. Lipids cannot be defined, as it is often done, as a class of natural compounds that share a high degree of solubility in organic solvents. This designation is at the same time too broad and too narrow: it encompasses a diversity of structurally and functionally unrelated molecules, paradoxically excluding partly water-soluble lipids such as gangliosides and phosphoinositides. The alternative definition proposed by W. Christie seems more adequate: “Lipids are fatty acids and their derivatives, and substances related biosynthetically or functionally to these compounds” [2]. By this definition, every biomolecule derived from the condensation of malonyl-coenzyme A units and implicated in cell structure and function should be considered as a lipid. To illustrate this point, in Table 1. I have listed a series of lipid classes, organized within the traditional taxonomy of ‘simple’ and ‘complex’ lipids. ‘Simple’ are called those lipids that on hydrolysis produce no more than two products – for example triacylglycerols, which give rise to fatty acids and glycerol. ‘Complex’ are instead those lipids that hydrolyze into three or more products – for example phosphatidylcholine, which generates fatty acids, glycerol, phosphate and choline.

3. Unit permutation

Within each lipid family, a great deal of structural and functional diversity can be achieved by permutation of a relatively small number of simple chemical units. A good illustration of

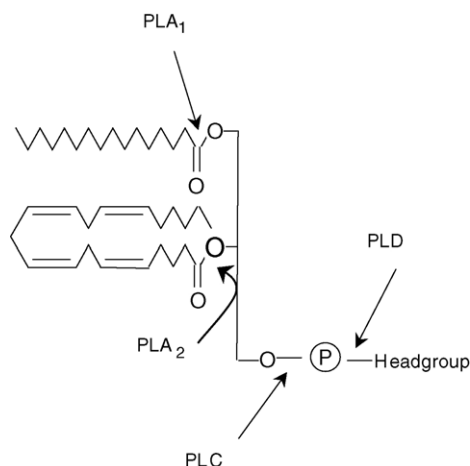

Fig. 1. General structure of a glycerophospholipid. The glycerol backbone is esterified at the *sn*-1 and *sn*-2 positions by two fatty-acid residues, and at the *sn*-3 position by a phosphate group linked to a polar headgroup. Arrows indicate the site of attack of three major phospholipase families: phospholipase A (PLA₁ and PLA₂), phospholipase C (PLC), and phospholipase D (PLD).

this phenomenon is provided by the glycerophospholipids – a phospholipid subfamily that consists of a glycerol backbone esterified at the *sn*-1 and *sn*-2 positions by two fatty-acid residues, and at the *sn*-3 position by a phosphate moiety linked to a polar headgroup (Fig. 1).

A first level of structural diversity within this subfamily is determined by the presence of different headgroups, which define six major glycerophospholipid classes: phosphatidic acid (PA), phosphatidylethanolamine (PE), phosphatidylcholine (PC), phosphatidylinositol (PI), and phosphatidylglycerol. Each of these classes has a specific distribution, not only among different cell types, but also among different organelles of the same cell. In fact, heterogeneities exist even within individual cell membranes – between the inner and outer leaflet of the plasmalemma [3], and between ‘lipid rafts’ and their surrounding membrane environment [4].

Such heterogeneities are dynamically regulated and can play striking functional roles. For example, in healthy cells PS is predominantly localized to the inner leaflet of the membrane bilayer, but this arrangement is disrupted during apoptosis due to the concomitant stimulation of the enzyme scramblase (which moves PS in both directions across the membrane leading to a loss of its asymmetric distribution) and inhibition of aminophospholipid translocase (which returns PS to the inner side of the membrane). After externalization, PS is recognized by a receptor present on the surface of macrophages and other phagocytes (including brain microglia), which initiates the non-inflammatory removal of apoptotic cells [5–7]. This chain of events is crucial to neural development. In fact, mutant mice lacking the PS receptor die in their infancy as a result of brain malformations associated with increased numbers of non-phagocytosed apoptotic cells [8].

A second layer of variation within the glycerophospholipids subfamily is introduced by the nature of the fatty-acid residues linked to the *sn*-1 and *sn*-2 position of the glycerol

backbone. These residues vary in chain-length, number of double bonds ('unsaturation'), cyclization and oxygenation, and affect phospholipid function in at least three ways. First, they influence the flexibility of individual phospholipid molecules and their ability to combine into supramolecular assemblies; for instance, the presence of saturated fatty acids, which are more rigid than unsaturated ones, contributes (along with a high local cholesterol content) to the tight packing and phase separation that characterize lipid rafts. The roles of these structures are still a bit of an enigma [9], but one possibility is that they serve as platforms to facilitate interactions among lipids and proteins involved in transmembrane signal transduction, including receptor tyrosine kinases and G protein-coupled receptors [4]. Second, fatty-acid residues determine the shape of individual phospholipid molecules and, by doing so, affect the spatial properties of the membrane bilayer. For example, the presence in the cytoplasmic leaflet of cone-shaped lipids such as PA induces a negative membrane curvature, whereas that of inverted-cone-shaped lipids such as lysophosphatidic acid (LPA, which lacks the fatty-acid residue in the *sn*-2 position) has the opposite effect [10]. The functional importance of these geometric variations is demonstrated by the finding that the enzymatic conversion of LPA to PA, catalyzed by the presynaptic fatty-acid transferase endophilin 1, may contribute to synaptic vesicle fission—the process through which highly curved vesicles are pinched off planar lipid bilayers [11].

Yet another level of diversity can be achieved by adding chemical modifiers to the glycerophospholipid headgroup. For example, the phosphorylation of hydroxyl groups on the inositol ring of PI, catalyzed by a family of PI-kinases, produces a heterogeneous subclass of phosphoinositides, each of which has rather unique cellular distribution and functional properties. Profiling studies have revealed the existence of as many as twenty distinct phosphoinositide species in a single cell type [12,13]. These biomolecules are often present at vanishingly low concentrations and are localized to specific subcellular organelles. Depending on differences in structure and localization, they may serve as precursors of intracellular messengers – e.g., PI(4,5)bisphosphate [14] – and as ligands for proteins involved in membrane dynamics – e.g., PI(3,4)bisphosphate [15].

Another important modification to the glycerophospholipid headgroup consists in the addition of a long-chain fatty acid to the primary amine moiety of PE (Fig. 2). This reaction, which in mammalian tissues is catalyzed by a Ca^{2+} -dependent *N*-acyltransferase, generates a quantitatively minor subclass of glycerophospholipids: the *N*-acylphosphatidylethanolamines (NAPEs). When attacked by a NAPE-selective phospholipase D [16], NAPEs produce a set of fatty-acid ethanolamides (FAEs) that act as intercellular signaling molecules [17] (Fig. 2). The fatty-acid substitution of the parent NAPE defines the informational properties of the FAE released: polyunsaturated FAEs such as arachidonylethanolamide (anandamide) serve as endogenous ligands for cannabinoid receptors – G protein-coupled receptors targeted by Δ^9 -tetrahydrocannabinol in marijuana [17,18] – whereas monounsaturated and saturated FAEs such as oleoylethanolamide (OEA) activate peroxysome proliferator-activated receptors type- α (PPAR- α) [19] – nuclear receptors involved in the control of feeding [20,21], lipid metabolism and neuroprotection [22].

All lipid classes catalogued in Table 1 achieve chemical diversity using the 'molecular Lego' strategy employed by the glycerophospholipids—even 'simple' lipids such as the diacylglycerols (DAG), monoacylglycerols (MAG) and fatty acids. In fact, these deceptively simple compounds exemplify another key feature of lipid signaling: the use of a

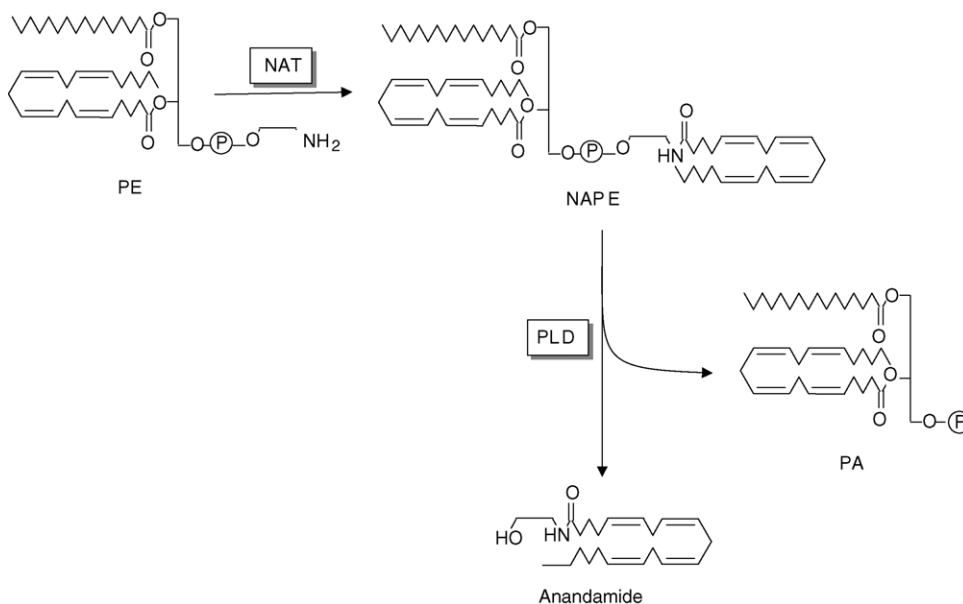

Fig. 2. Pathways of fatty-acid ethanolamide formation, as exemplified by anandamide formation. *N*-Acyltransferase (NAT) catalyzes the transfer of a fatty-acid residue from the sn-1 position of phosphatidylcholine (not shown) to the free amino group of phosphatidylethanolamine (PE), producing *N*-acylphosphatidylethanolamine (NAPE). NAPE is cleaved by a NAPE-selective phospholipase D (PLD) to yield phosphatidic acid (PA) and a fatty-acid ethanolamide such as anandamide (arachidonylethanolamide).

single biochemical cascade to generate sequences of functionally independent informational molecules.

4. Serial signalling

When a hormone or neurotransmitter binds to a receptor on the membrane of a target cell, it triggers the formation of second messengers that are responsible for translating receptor occupancy into cellular responses. For example, the binding of dopamine D_1 receptors to neurons stimulates the activity of adenylyl cyclase, which catalyzes the conversion of ATP into cyclic AMP. This second messenger binds to and activates protein kinase A, which phosphorylates select intracellular proteins and modifies their biological activity. This sequence of events is halted by the hydrolytic cleavage of cyclic AMP, which terminates its biological actions. A similar 'one pathway-one signal' model of transmembrane signaling applies to other hydrophilic second messengers, such as cyclic GMP and inositol-(1,4,5)-trisphosphate, but not to most lipid messengers. The latter have evolved a more complex way of carrying out their functions, which is well illustrated by the 1,2-DAG cascade (Fig. 3).

The enzymatic cleavage of membrane PI(4,5)bisphosphate by specific C-type phospholipases (Fig. 1) generates two second messengers: Ins(1,4,5)trisphosphate, which releases calcium from the endoplasmic reticulum, and 1,2-DAG, which activates various members of the protein kinase C family of enzymes [14]. Ins(1,4,5)trisphosphate shares the fate of other hydrophilic messengers—it produces its effects and is rapidly deactivated. In contrast, 1,2-DAG is the starting point for a series of competing biotransformations, which can give rise to a bewildering array of bioactive mediators (Fig. 3).

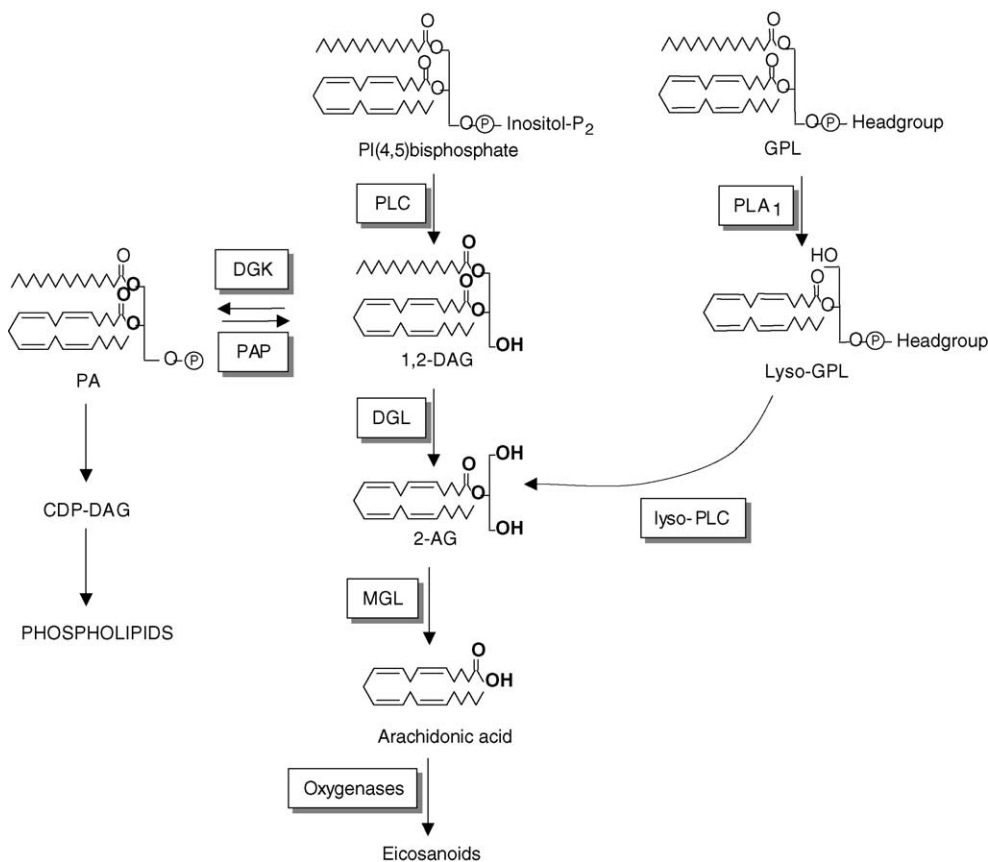

Fig. 3. The 1,2-diacylglycerol (DAG) cascade. Cleavage of phosphatidylinositol (PI)(4,5)bisphosphate by selective phospholipases C (PLC) produces 1,2-DAG. 1,2-DAG is phosphorylated by DAG-kinases (DGK) to yield phosphatidic acid (PA), which can be dephosphorylated back to 1,2-DAG by PA phosphatase (PAP) or can be converted to cytidylphosphate-DAG en route to phospholipids biosynthesis. Alternatively, 1,2-DAG is hydrolyzed by DAG-lipases (DGL) to produce 2-arachidonoylglycerol (2-AG), which is cleaved by monoacylglycerol lipase (MGL) to form arachidonic acid, a precursor for the eicosanoids. 2-AG might also be generated through phospholipase A₁ (PLA₁)-mediated hydrolysis of a glycerophospholipid (GPL), which forms a lyso-GPL. The latter might be converted to 2-AG by lysophospholipase C (lyso-PLC).

A family of DAG-kinases catalyzes the phosphorylation of 1,2-DAG to PA [23], which has, in turn, three metabolic options: it can lose a fatty-acid residue to phospholipase A₂ activity, forming LPA; it can be funneled toward phospholipid synthesis through conversion to cytidyldiphosphate-DAG; or it can be dephosphorylated back to 1,2-DAG by PA phosphatase [3]. Alternatively, 1,2-DAG can be hydrolyzed by DAG-lipases (DGL) to yield MAG [24], which is then further hydrolyzed by MAG lipase (MGL) to produce fatty acid and glycerol [25,26]. Since the *sn*-2 position of PI(4,5)bisphosphate is generally occupied by an arachidonate moiety, the two primary end-products of 1,2-DAG hydrolysis are 2-arachidonoylglycerol (2-AG) and arachidonic acid. Both compounds are excellent substrates for several lipid oxygenases (e.g., cyclooxygenase-2), which convert them to a family of oxidized metabolites called eicosanoids [27].

Virtually every metabolic intermediate in the 1,2-DAG cascade has been implicated in neural signaling: PA activates raf protein kinase and PI(4)monophosphate-5-kinase [28]; LPA and 2-AG are high-affinity agonists for LPA and cannabinoid receptors, respectively, thus serving key functions in neural development, synaptic plasticity and behavior [17,29]; arachidonic acid modulates the activities of various neuronal ion channels and protein kinases [30]; and the eicosanoids engage a group of G protein-coupled receptors that are crucially involved in pain and neuroinflammation [31,32].

How do nerve cells coordinate the different and often conflicting messages generated by ‘serial signaling’ pathways such as the 1,2-DAG cascade? With some imagination, we can picture a system of biochemical switches and topological constraints that could favor one pathway over another, or stop a sequence of reactions in the middle of its course. These ideas will remain speculative, however, until we understand how neurotransmitters, hormones and drugs globally alter lipid pathways.

5. On-demand signaling

Neurotransmitters and neuropeptides are stored in specialized vesicles and are released from nerve endings when internal Ca²⁺ levels rise and stimulate the secretory process. In contrast, lipid mediators are produced on demand through enzymatic cleavage of membrane phospholipids precursors.

A large number of primary signals control the mobilization of lipid messengers. As a rule, they do so in a seemingly straightforward way, namely by activating membrane receptors and ion channels linked to phospholipases. But the structures of these receptors and channels, the phospholipases they are linked to, and their precise coupling mechanisms can be widely different. In fact, there are so many variations on this theme that it would take more than this entire article even to outline them in brief. So, I will illustrate this concept using as an example the formation of two endocannabinoid substances present in the brain: anandamide and 2-AG [17].

Anandamide generation in brain neurons requires two enzymatic steps, which are depicted in Fig. 2. The first is the stimulus-dependent cleavage of a subtype of NAPE, *N*-arachidonoyl-PE; this reaction is mediated by NAPE-selective phospholipase D and produces anandamide and PA [16]. The rat brain contains tiny quantities of *N*-arachidonoyl-PE, but the cellular stores of this precursor can be rapidly replenished by *N*-acyltransferase (NAT), which catalyzes the intermolecular passage of an arachidonic acid residue from the

sn-1 position of PC to the headgroup of PE [33,34]. In neurons, two intracellular second messengers control NAT activity: Ca^{2+} and cyclic AMP. Ca^{2+} is required to engage NAT, which is inactive in its absence, whereas cyclic AMP works through protein kinase A-dependent phosphorylation to enhance NAT activity. Although catalyzed by separate enzymes, the syntheses of anandamide and *N*-arachidonoyl-PE are thought to proceed in parallel [34].

As expected of a Ca^{2+} -activated process, neuronal anandamide formation can be elicited by a number of membrane-depolarizing agents, such as the glutamate receptor agonist kainate [33,35]. Perhaps more interestingly, anandamide can also be produced through activation of G protein-coupled receptors. Thus, the dopamine D_2 agonist quinpirole causes a marked stimulation of anandamide outflow in the rat striatum, as assessed by microdialysis, which is prevented by the D_2 antagonist raclopride [36]. How does D_2 -receptor occupation translate into anandamide formation? Although we cannot answer this question yet, it is important to note that D_2 -receptor activation does not change the levels of 2-AG, suggesting that the syntheses of these two endocannabinoid substances are independently regulated [36].

The biochemical pathway(s) responsible for the production of 2-AG are less well understood than anandamide's. Current information suggests two possible routes. The first is through the 1,2-DAG cascade, which we have outlined before (Fig. 3). The fact that pharmacological inhibitors of phospholipase C and DAG-lipase block 2-AG accumulation in rat neurons points to a primary involvement of this pathway in the physiological formation of 2-AG [37]. Alternatively, 2-AG synthesis may begin with the production, mediated by phospholipase A_1 , of a 2-arachidonoyl-lysophospholipid, which might be hydrolyzed to 2-AG by a lyso-PLC activity (Fig. 3). In addition, 2-AG might be produced by hormone-sensitive lipase acting on triacylglycerols or by lipid phosphatase acting on LPA. However, these enzymes preferentially target lipids enriched in saturated or monounsaturated fatty acids, rather than the arachidonate-containing species needed to produce 2-AG.

Irrespective of the mechanism involved, neuronal 2-AG production can be initiated by a rise in intracellular Ca^{2+} . The glutamate receptor agonist *N*-methyl-D-aspartate (NMDA) stimulates 2-AG synthesis in rat cortical neurons via a Ca^{2+} -dependent mechanism [38]. Likewise, electrical stimulation of the Schaffer collaterals, a glutamatergic fiber tract that connects the CA3 to CA1 field in the hippocampus, produces a Ca^{2+} -dependent increase in hippocampal 2-AG content [37]. Importantly, the same stimulation does not alter local anandamide levels, confirming that 2-AG and anandamide can be produced independently of each other [37].

The on-demand release mechanism, exemplified above with the endocannabinoids, is a common theme in lipid signaling and is associated with another characteristic of lipid mediators: their preference to act in close proximity of the cells where they are produced.

6. Local actors

The localized actions of lipid messengers were first documented for the eicosanoids, a family of oxygenated metabolites of arachidonic acid that includes prostaglandin E_2 and

thromboxane A₂ (TXA₂) [30]. For example, TXA₂ is produced by stimulated platelets and induces vascular constriction and platelet aggregation by interacting with prostanoid TP receptors present on the surface of nearby platelets and smooth muscle cells [39]. In the brain, the endocannabinoids might act in a similar way to provide a retrograde signaling mechanism through which neurons alter the strength of incoming synaptic inputs. When pyramidal neurons in the hippocampus are depolarized, the inhibitory input received by those cells is transiently suppressed. This phenomenon is initiated postsynaptically by voltage-dependent influx of Ca²⁺ into the neuron, but is expressed presynaptically through inhibition of transmitter release from axon terminals of GABAergic interneurons. This suggests that a chemical messenger generated during depolarization of the pyramidal cell travels backwards across the synapse. There is strong evidence that an endocannabinoid lipid, possibly 2-AG, is involved in this retrograde signaling process. A similar form of backward signaling is initiated by the activation of postsynaptic glutamate metabotropic receptors and acetylcholine muscarinic receptors [17,40].

7. Technical coda

Quantifying minute amounts of lipids in complex biological mixtures is a difficult task, which becomes even harder when the analytical target is not a specific lipid, but the mixture itself—which is the goal of lipidomics. Though daunting, this challenge can now be met thanks to advances in separation and identification techniques and to the development of statistical methods capable of handling high volumes of complex data [12]. Proteomics has also provided a useful precedent in this respect, which the newer discipline of lipidomics can build upon.

Nevertheless, as I have noted throughout this article, lipids pose a unique set of biological problems, which call for original technical solutions. ‘Unit permutation’ dictates that lipid molecules with slightly different or even identical mass can have distinct functional properties; this implies that lipidomic approaches must include more detailed structural information than mass alone; one way to accomplish this is using multistage electrospray ionization mass spectrometry [12]. Furthermore, the complex lipid networks that underlie ‘serial signaling’ can only be disentangled by carefully quantifying sequences of precursors and products; this is not a trivial undertaking, as it requires the simultaneous monitoring of lipids with widely different chemical properties and analytical behaviors—for example, PI(4,5)bisphosphate, 1,2-DAG and 2-AG (Fig. 3). Last, but not least, the ‘on-demand’ and local nature of lipid signaling imposes both temporal and topological constraints on the analytical process, which must be taken into consideration for the analysis to be physiologically meaningful; this problem could be addressed by incorporating snap-freezing and laser-capture microdissection techniques into lipidomic protocols.

Surely, these are very difficult challenges. Nevertheless, it is true what a great physicist once said – “if you can’t measure it, it doesn’t exist” – then it is clear that quantitative lipidomics is needed to finally bring into existence the richness of brain lipid signaling.

Acknowledgments

I wish to thank all the members of my lab for their many contributions, NIDA for its financial support, and M. Kochav for editorial help with this manuscript.

References

- [1] Lehninger AL. Biochemistry. New York: Worth Publishers, Inc.; 1975.
- [2] Christie WW. Gas chromatography and lipids. Ayr: The Oily Press Ltd.; 1989.
- [3] Thompson Jr GA. The regulation of membrane lipid metabolism. Ann Arbor: CRC Press; 1992.
- [4] Pike LJ. Lipid rafts: heterogeneity on the high seas. *Biochem J* 2004;378:281.
- [5] Fadok VA, Bratton DL, Rose DM, Pearson A, Ezekewitz RA, Henson PM. A receptor for phosphatidylserine-specific clearance of apoptotic cells. *Nature* 2000;405:85.
- [6] Henson PM, Bratton DL, Fadok VA. The phosphatidylserine receptor: a crucial molecular switch? *Nat Rev Mol Cell Biol* 2001;2:627.
- [7] De SR, Ajmone-Cat MA, Nicolini A, Minghetti L. Expression of phosphatidylserine receptor and down-regulation of pro-inflammatory molecule production by its natural ligand in rat microglial cultures. *J Neuropathol Exp Neurol* 2002;61:237.
- [8] Li MO, Sarkisian MR, Mehal WZ, Rakic P, Flavell RA. Phosphatidylserine receptor is required for clearance of apoptotic cells. *Science* 2003;302:1560.
- [9] Munro S. Lipid rafts: elusive or illusive? *Cell* 2003;115:377.
- [10] Huttner WB, Schmidt AA. Membrane curvature: a case of endofeelin. *Trends Cell Biol* 2002;12:155.
- [11] Schmidt A, Wolde M, Thiele C, et al. Endophilin I mediates synaptic vesicle formation by transfer of arachidonate to lysophosphatidic acid. *Nature* 1999;401:133.
- [12] Ivanova PT, Milne SB, Forrester JS, Brown HA. Lipid arrays: new tools in the understanding of membrane dynamics and lipid signaling. *Mol Interv* 2004;4:86.
- [13] Wenk MR, Lucast L, Di Paolo G, et al. Phosphoinositide profiling in complex lipid mixtures using electrospray ionization mass spectrometry. *Nat Biotechnol* 2003;21:813.
- [14] Irvine RF. 20 years of Ins(1,4,5)P₃, and 40 years before. *Nat Rev Mol Cell Biol* 2003;4:586.
- [15] Rodgers EE, Theibert AB. Functions of Pi 3-kinase in development of the nervous system. *Int J Dev Neurosci* 2002;20:187.
- [16] Okamoto Y, Morishita J, Tsuboi K, Tonai T, Ueda N. Molecular characterization of a phospholipase D generating anandamide and its congeners. *J Biol Chem* 2004;279:5298.
- [17] Piomelli D. The molecular logic of endocannabinoid signaling. *Nat Rev Neurosci* 2003;4:873.
- [18] Devane WA, Breuer A, Sheskin T, Jarbe TU, Eisen MS, Mechoulam R. A novel probe for the cannabinoid receptor. *J Med Chem* 1992;258:2065.
- [19] Fu J, Gaetani S, Oveisi F, et al. Oleylethanolamide regulates feeding and body weight through activation of the nuclear receptor Ppar-alpha. *Nature* 2003;425:90.
- [20] Rodríguez de Fonseca F, Navarro M, Gómez R, et al. An anorexic lipid mediator regulated by feeding. *Nature* 2001;414:209.
- [21] Gaetani S, Oveisi F, Piomelli D. Modulation of meal pattern in the rat by the anorexic lipid mediator oleylethanolamide. *Neuropsychopharmacology* 2003;28:1311.
- [22] Evans RM, Barish GD, Wang YX. Ppars and the complex journey to obesity. *Nat Med* 2004;10:355.
- [23] Topham MK, Prescott SM. Diacylglycerol kinases: regulation and signaling roles. *Thromb Haemost* 2002;88:912.
- [24] Bisogno T, Howell F, Williams G, et al. Cloning of the first Sn1-Dag lipases points to the spatial and temporal regulation of endocannabinoid signaling in the brain. *J Cell Biol* 2003;163:463.
- [25] Karlsson M, Contreras JA, Hellman U, Tornqvist H, Holm C. cDNA cloning, tissue distribution, and identification of the catalytic triad of monoglyceride lipase. evolutionary relationship to esterases, lysophospholipases, and haloperoxidases. *J Biol Chem* 1997;272:27218.

- [26] Dinh TP, Carpenter D, Leslie FM, et al. Brain monoglyceride lipase participating in endocannabinoid inactivation. *Proc Natl Acad Sci USA* 2002;99:10819.
- [27] Kozak KR, Prusakiewicz JJ, Marnett LJ. Oxidative metabolism of endocannabinoids by Cox-2. *Curr Pharm Des* 2004;10:659.
- [28] McDermott M, Wakelam MJ, Morris AJ, Phospholipase D. *Biochem Cell Biol* 2004;82:225.
- [29] Ye X, Fukushima N, Kingsbury MA, Chun J. Lysophosphatidic acid in neural signaling. *Neuroreport* 2002;13:2169.
- [30] Piomelli D. *Arachidonic acid in cell signaling*. New York: R.G. Landes Company Austin; 1996.
- [31] Samad TA, Saperstein A, Woolf CJ. Prostanoids and pain: unraveling mechanisms and revealing therapeutic targets. *Trends Mol Med* 2002;8:390.
- [32] Consilvio C, Vincent AM, Feldman EL. Neuroinflammation, Cox-2, and Als—a dual role? *Exp Neurol* 2004;187:1.
- [33] Di Marzo V, Fontana A, Cadas H, et al. Formation and inactivation of endogenous cannabinoid anandamide in central neurons. *Nature* 1994;372:686.
- [34] Cadas H, Di Tomaso E, Piomelli D. Occurrence and biosynthesis of endogenous cannabinoid precursor, *N*-arachidonoyl phosphatidylethanolamine, in rat brain. *J Neurosci* 1997;17:1226.
- [35] Cadogan AK, Alexander SP, Boyd EA, Kendall DA. Influence of cannabinoids on electrically evoked dopamine release and cyclic Amp generation in the rat striatum. *J Neurochem* 1997;69:1131.
- [36] Giuffrida A, Parsons LH, Kerr TM, Rodríguez de Fonseca F, Navarro M, Piomelli D. Dopamine activation of endogenous cannabinoid signaling in dorsal striatum. *Nat Neurosci* 1999;2:358.
- [37] Stella N, Schweitzer P, Piomelli D. A second endogenous cannabinoid that modulates long-term potentiation. *Nature* 1997;388:773.
- [38] Stella N, Piomelli D. Receptor-dependent formation of endogenous cannabinoids in cortical neurons. *Eur J Pharmacol* 2001;425:189.
- [39] FitzGerald GA. Cardiovascular pharmacology of nonselective nonsteroidal anti-inflammatory drugs and coxibs: clinical considerations. *Am J Cardiol* 2002;89:26D.
- [40] Alger BE. Retrograde signaling in the regulation of synaptic transmission: focus on endocannabinoids. *Prog Neurobiol* 2002;68:247.