

# Lawrence Berkeley National Laboratory

## Recent Work

### **Title**

AN ELECTRON ACCELERATOR FOR TUNNELING THROUGH HARD ROCK

### **Permalink**

<https://escholarship.org/uc/item/9377t0j9>

### **Author**

Avery, Robert T.

### **Publication Date**

1975-10-01

Presented at the International Topical  
Conference on Electron Beam Research  
and Technology, Albuquerque, NM,  
November 3 - 5, 1975

LBL-4231

c.1

AN ELECTRON ACCELERATOR FOR TUNNELING  
THROUGH HARD ROCK

Robert T. Avery and Denis Keefe

October 1975

Prepared for the U. S. Energy Research and  
Development Administration under Contract W-7405-ENG-48  
with the financial support of the National Science  
Foundation (RANN) under NSF Grant AG-393

**For Reference**

Not to be taken from this room

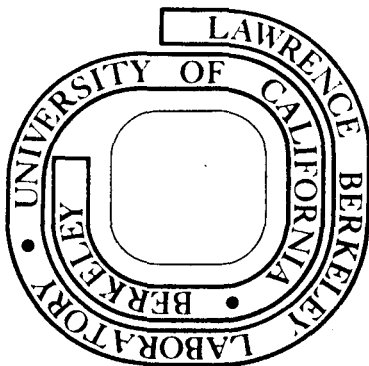

LBL-4231

c.1

00004401597

## **DISCLAIMER**

This document was prepared as an account of work sponsored by the United States Government. While this document is believed to contain correct information, neither the United States Government nor any agency thereof, nor the Regents of the University of California, nor any of their employees, makes any warranty, express or implied, or assumes any legal responsibility for the accuracy, completeness, or usefulness of any information, apparatus, product, or process disclosed, or represents that its use would not infringe privately owned rights. Reference herein to any specific commercial product, process, or service by its trade name, trademark, manufacturer, or otherwise, does not necessarily constitute or imply its endorsement, recommendation, or favoring by the United States Government or any agency thereof, or the Regents of the University of California. The views and opinions of authors expressed herein do not necessarily state or reflect those of the United States Government or any agency thereof or the Regents of the University of California.

# AN ELECTRON ACCELERATOR FOR TUNNELING THROUGH HARD ROCK\*

Robert T. Avery and Denis Keefe\*\*

Lawrence Berkeley Laboratory  
University of California  
Berkeley, California

## Abstract

Earlier work<sup>1-3</sup> demonstrated that intense sub-microsecond bursts of energetic electrons cause significant pulverization and spalling of a variety of rock types. The spall debris generally consists of sand, dust, and small flakes. If carried out at rapid repetition rate, this can lead to a promising technique for increasing the speed and reducing the cost of underground excavation of tunnels, mines and storage spaces. The conceptual design features of a Pulsed Electron Tunnel Excavator capable of tunneling approximately ten times faster than conventional drill/blast methods are presented with primary emphasis on the electron accelerator and only a brief description of the tunneling aspects. Of several candidate types of accelerators, a linear induction accelerator producing electron pulses (5 MV, 5 kA, 1.0  $\mu$ s = 25 kJ) at a 360 Hz rate was selected for the conceptual example. This provides the required average electron beam power output of 9 MW. The feasibility of such an accelerator is discussed.

---

\* Work supported by the National Science Foundation under the auspices of the U.S. Energy Research and Development Administration.

\*\* Denis Keefe is on leave at Princeton University, Plasma Physics Laboratory.

## Introduction

There is a national need for more rapid and economical methods of tunneling for undergrounding of power plants, energy storage facilities (compressed air, hydro, fuel, thermal, etc.), transmission lines, 300 mph inter-city trains, urban transit, factories and warehouses. The surface environment can be greatly improved as a result. For soil and soft rock, mechanical moles have already speeded up tunneling rates significantly. However, for hard rock, drill/blast methods are slow, with advance rates seldom exceeding 2.5-3.0 m (8-10 ft.) per 8-hour shift. Thus, there remains a need for great improvement in hard rock tunneling rates.

### 1. Rock Spalling by Pulsed Electron Beams

The successful spalling of granite, basalt, greenstone and other rocks using single high-current high-voltage (1-4 MV) electron pulses of less than 1  $\mu$ s duration have been reported previously.<sup>1,2</sup> Spalling also has been successfully demonstrated<sup>3</sup> in experiments using the ~ 9 MV Hermes II accelerator at Sandia-Albuquerque which delivered 64 kJ per shot to each rock sample. The resulting spall and debris for several single-pulse shots are shown in Fig. 1. The spalls were 7-15 mm deep by 120-130 mm diameter with volume removed (neglecting any corners knocked off) of 51-82 cm<sup>3</sup>. This corresponds to specific energies (energy deposited/volume removed) of 0.78 to 1.25 kJ/cm<sup>3</sup>.

Generally, the depth of the spall was found to vary roughly as the voltage of the electrons, and the volume of the spall roughly as the energy content (joules) of the beam pulse. Hard rocks spalled almost as readily as soft rocks. Generally, wet rocks spalled somewhat more than dry rocks.

The fracture mechanisms occurring on this very short time-scale are

becoming better understood.<sup>3,4</sup> The principal mechanism results from electron bombardment heating of the first centimeter or so of the rock in a time duration of a fraction of a microsecond. This produces a thermomechanical compressive stresswave which reflects from the front surface as a tensile stresswave which fractures the rock. In the case of wet rocks this is supplemented by thermally-induced pressure within the interstitial water. These mechanisms take advantage of the fact that rocks are much weaker in tension than in compression. All of the fracturing occurs within a few microseconds.

## 2. Specific Energy for a Useful Excavating Accelerator

The foregoing experiments were carried out at existing available accelerators under a limited range of operating conditions. In particular, the radial distribution of beam intensity typically was sharply peaked in the center with relatively large tails; also all experiments were carried out on a single-shot basis. A more uniform current distribution could require as little as one-third as much specific energy. Further, if rapid-fire operation were used, there is reason to believe that larger volume of spalls would result because of heating and/or incipient cracking produced by preceding pulses. Thus, for a rapid repetition-rate accelerator designed specially for excavation, it is reasonable to expect lower specific energies (perhaps 100-400 J/cm<sup>3</sup> or less) than the ~ 1.0 kJ/cm<sup>3</sup> reported above. For design purposes, a value of 250 J/cm<sup>3</sup> is assumed. In arriving at the required accelerator output, a 25% allowance is added to the foregoing value to compensate for losses in windows and in the air, and for albedo, x-ray production, etc.

### 3. Example Pulsed Electron Tunnel Excavator

This paper concentrates on an example accelerator with 9 MW average beam power, which would thus be capable of removing  $104 \text{ m}^3$  (136 cu. yds.) of rock per hour, or in other words advance a 6.4 m (21 ft.) diameter tunnel at a rate of 3.2 m (10.6 ft) per hour. This is about an order-of-magnitude greater advance rate than by present-day drill/blast techniques.

To assess the possibilities of this technique for rapid tunneling, the conceptual design of a Pulsed Electron Tunnel Excavator has been prepared.<sup>5-7</sup> Several features of this excavator are shown in Figures 2 through 6. Note that the accelerator proper is just one element -- though a large one -- in the overall design, which also integrates provisions for major construction functions such as tunnel lining, muck removal and ventilation on a continuous basis. Access is available to handle unusual circumstances which might be encountered near the tunnel face.

A linear induction accelerator<sup>8-10</sup> producing electron pulses (5 MV, 5 kA,  $1.0 \mu\text{s} = 25 \text{ kJ}$ ) at a 360 Hz rate has been selected for this example, thus providing the required average electron beam power output of 9 MW. The accelerator will consist of 64 accelerating modules each producing 80 kV pulsed voltage. A module may be thought of as a pulse transformer in which the transformer cores are driven by pulse-forming networks connected in parallel to the primary windings and in which the electron beam constitutes a single series-connected secondary circuit. The electron beam pulses will be scanned by a combination of (slow) mechanical and (fast) magnetic means across the rock at the tunnel face in a prescribed pattern.

Types of accelerators which were considered, other than the linear induction accelerator, were 1) coax and Blumlein concentric pulseline accelerators

(e.g. Sandia's Hermes II machine and "Pulserad" accelerators manufactured by Physics International Co.), 2) transformer accelerators<sup>11</sup> (such as the Electro-pulse marketed by Energy Sciences Inc.), and 3) Marx generators and similar capacitor-storage accelerators. The linear induction accelerator was selected for this design example because a) its modular construction permits continued operation at near full output in the event one or a few modules should fail; b) only modest voltages (< 100 kV) to ground exist; c) the stored energy that can be released in an arc breakdown is limited to one module (less damage); d) voltage output can be regulated at a steady level during the pulse thereby facilitating beam transport and scanning; and e) overall electrical efficiencies (incoming AC power to electron beam power) of better than 50% appear achievable.

The spall debris is mostly sand, dust, and small flakes, but larger pieces may be produced also. The bulk of the debris will be picked up pneumatically at the face and then placed in an hydraulic slurry pipeline for transport to the tunnel entrance. Slurry transport is a fast, continuous and economical technique<sup>12</sup> for transporting large volumes of muck. Large pieces will be coped with by a conveyor at the face and then crushed and slurry-transported. A belt conveyor and muck cars are shown also, but they may not be needed.

Tunnel support and lining will be provided by a partial tunnel shield (surrounding the scanner) followed immediately by casting of the final concrete lining using either slipform or extrusion means. Concrete supplies will be transported to the face by pipe or conveyor. Alternatively, pre-cast concrete segments or structural steel sets could be placed instead, but they would require interruption of accelerator operation during their installation.

The accelerator will produce intense x-rays during operation. The operating crew will be fully protected by a shielding system of concrete, water and



safety doors built into one unit of the excavator. The several meters of rock cover which is (by definition) over the tunnel protects the general public. Recent irradiations of rock samples at Berkeley confirm that there is no induced radioactivity for the selected parameters; thus when the machine is turned off, the crew can approach the tunnel-face immediately.

Ozone will be produced when the electron beam passes through air to reach the rock face. Pneumatic suction at the face followed by the negative-pressure exhaust ventilation duct will transport the ozone to the tunnel entrance where it will be diluted with air or chemically treated.

#### 4. Accelerator Development

It appears that most, if not all, of the performance parameters for the Pulsed Electron Tunnel Excavator are within the capabilities of the existing state-of-the-art. However, a development program related to both the accelerator and the tunneling systems will be required and several of the principal development items are discussed here.

##### 4.1 Scanning System

The requirements for the scanning system are severe as it must transmit 9 MW of electron beam from high vacuum to air, must scan in a reasonably precise manner, and must survive for long periods of time in the hostile tunnel environment without being damaged by either the spall debris or the electron beam. Several promising approaches are under consideration. One consists of passing the electrons through a directly water-cooled foil window<sup>13</sup> for high vacuum isolation followed by a modestly-evacuated mechanically-moved snout at the end of which is a moveable foil-window (located about 10 cm from the rock face). Other possibilities include such schemes as, 1) a series of beam aper-

which provide vacuum grading, 2) rotating beam apertures which are open only momentarily when the beam is pulsed, 3) a hundred or so individual windows with electro-magnetic scanning, or 4) a water film flowing on the outside of a window.

The various alternative solutions need much additional study and testing, including fabrication of engineering models and simulated testing for several of the more promising solutions. The scanning system represents the toughest development item for the Pulsed Electron Tunnel Excavator, but fortunately, many candidate solutions have already come to light. It appears that some one or a combination of such methods will prove suitable.

#### 4.2 Electron Gun

Cathodes developing much greater pulse currents (even megamperes) have been built, but for very slow repetition rates. On the other hand, cathodes in klystrons used in radar pulsers operate at more than 360 Hz, but at a factor of a hundred, or so, less current. Cathodes for the Astron electron accelerator<sup>8</sup> have successfully generated currents of ~ 1 kA at 300 ns duration and 30 Hz rate. The technology appears to be available to design and build a larger cathode suitable for the intended end use.

#### 4.3 Electron Beam Propagation

High-current pulses of electrons are known to interact strongly with the walls of any surrounding conductive enclosure, particularly at discontinuities. This interaction can lead to destructive instabilities of the electron beam which can drive the beam into the walls. In recent years, this phenomenon has become better understood and remedies are available. Laboratory tests can be conducted on representative model configurations to determine their excitation characteristics and beam propagation capability. These should lead to suitable configurations.

#### 4.4 Accelerating Module

The design of an accelerating module, such as that shown in Figure 5, appears reasonably straight-forward. However, the eddy current and hysteresis losses in the steel core cannot be predicted accurately for the very short duration pulses. Also, there is a choice of using expensive steel with moderate losses or cheaper steel with higher losses. Further study is indicated to determine which type is most suitable.

There is a choice on the switchtubes used to transfer power from the pulse-forming network (PFN) to the accelerating module. Ignitrons are a rugged, quite reliable and relatively inexpensive switching device commonly used in large power rectifiers, inverters, and welders. A leading developer of ignitrons believes that an existing "standard" ignitron can be modified to be suitable for the service that is needed here. Performance close to the desired ratings has been achieved previously. An ignitron and its associated socket cost less than \$1,000 each -- a modest cost even for the 64 needed for the full-size excavator. Thyratrons are a different type of switchtube with some existing models being suitable for this service. However, they are about ten times as expensive and more than one may be needed in place of each ignitron. This would represent a dominant, but not overwhelming, cost item for the full-size excavator. Thus, there is strong incentive to conduct development tests to determine if the ignitrons are suitable.

#### 4.5 Spalling Analysis

Bombardment tests to date have indicated that wet rocks generally spall more than dry rocks. However, all of these tests were performed with very short duration pulses. For dry rocks, the spalling process is better understood and it is known that the electron pulse duration must not be large compared to

the stress wave (sonic) transit time through the bombarded depth. Is there a similar limitation for wet rocks? If not, considerably longer pulses might be considered at reduced repetition rate. This could considerably ease the requirements on the switchtubes with possibly large economic savings. Better understanding of the spalling process should lead to selection of more suitable parameters for the electron accelerator and its components.

#### 4.6 Reliability

Most of the components for the electron accelerator can be designed for long life. Capacitors and transformers, when properly designed and derated, can have lifetimes of tens of years. The same should be true of the induction cores of the accelerating units. This is fortunate, since a high degree of reliability is needed if the Pulsed Electron Tunnel Excavator is to achieve its goal of rapid and continuous excavation through hard rock. One of the best ways to achieve high reliability is to make reliability analyses and perform the associated component reliability measurements.

#### 4.7 Pilot-Plant and Demonstration Excavators

Discussions with tunneling machine manufacturers lead us to the conclusion that the Government will have to support development not only through construction and testing of a "pilot plant" excavator but also through construction and testing of a full-size "demonstration plant" excavator that shows that the technique is practical and economical. Subsequent design refinement and improvement of the technique can, and likely would, be undertaken by industry. Manufacturers should be involved in the pilot and demonstration programs to the maximum extent practicable so as to speed the transition of the new method into production.

## 5. Conclusion

Sub-microsecond intense pulses of electrons are highly effective in spalling rock. Supplied at a rate of hundreds of times per second, they provide a technique that could lead to a Pulsed Electron Tunnel Excavator capable of converting hard-rock tunneling from a batch process into a rapid continuous process with possibly a ten-fold increase in advance rates compared to the conventional drill/blast method. Further study and development of components followed by construction of pilot and demonstration excavators are needed to prove the economic practicality of such an approach.

## Acknowledgements

We wish to acknowledge our colleagues on this project, T.L. Brekke and I. Finnie, of the School of Engineering of the University of California, Berkeley, who have provided expertise on tunnel engineering and fracture mechanics.

This program also has been aided greatly by the work and cooperation of such a large number of other people, not only at our institutions but also at other laboratories and in industry, that we regret that space limitations prevent us from here acknowledging them individually. We thank NSF for financial support under NSF Grant AG-393 and ERDA/AEC for use of facilities.

References

1. R. Avery, D. Keefe, T. Brekke, and I. Finnie, "Shattering Rock with Intense Bursts of Energetic Electrons", IEEE Trans. Nucl. Sci. NS-20, No. 3 (1973) [LBL-1391].
2. R. Avery, D. Keefe, T. Brekke, and I. Finnie, "Use of Intense Sub-Microsecond Electron Bursts to Produce Rock Shattering", Advances in Rock Mechanics II B, Proc. 3rd Congress of Intl. Soc. Rock Mech., Natl. Acad. Sci. (1974) [LBL-2137].
3. R.T. Avery, "Study of Rock Shattering by Intense Bursts of Energetic Electrons", D. Eng. Thesis, U. of Calif. (1974) [LBL-3019].
4. O. Vardar, "Fracture of Brittle Solids Under Multiaxial and Dynamic Loading", Ph.D. Thesis, U. of Calif. (1975) [LBL-3240].
5. R. Avery, D. Keefe, T. Brekke, and I. Finnie, "Hard-Rock Tunneling Using Pulsed Electron Beams", IEEE Trans. Nucl. Sci. NS-22, No. 3 (1975) [LBL-3377].
6. C.P. Adkins and T.L. Brekke, "Some Construction Considerations for Tunneling with the Energetic Electron Burst Method", UCID-3719 (1974).
7. R. Avery, D. Keefe, T. Brekke, and I. Finnie, "Rock Shattering with Energetic Electrons -- A New Method for Hard-Rock Tunneling", LBL-3246 (To be published, 1975).
8. J.W. Beal, N.C. Chrostofilos, and R.E. Hester, "The Astron Linear Accelerator, IEEE Trans. Nucl. Sci. NS-16, No. 3 (1969).
9. R. Avery, et al., "The ERA 4 MeV Injector", IEEE Trans. Nucl. Sci. NS-18, No. 3 (1971) [UCRL-20174].

10. J.E. Leiss, "Modern Electron Linacs and New User Needs", Proc. 1972 Proton Linac Conf., LASL Report LA-5115 (1972).
11. E.A. Abramyan, "Transformer Type Accelerators for Intense Electron Beams", IEEE Trans. Nucl. Sci. NS-18, No. 3, p. 447 (1971).
12. R.R. Faddick, and J.W. Martin, "Pneumatic-Hydraulic Material Transport System for Rapid Excavation of Tunnels", Report DOT-TST-75-17, (1975).
13. J.E. Leiss, private communications.

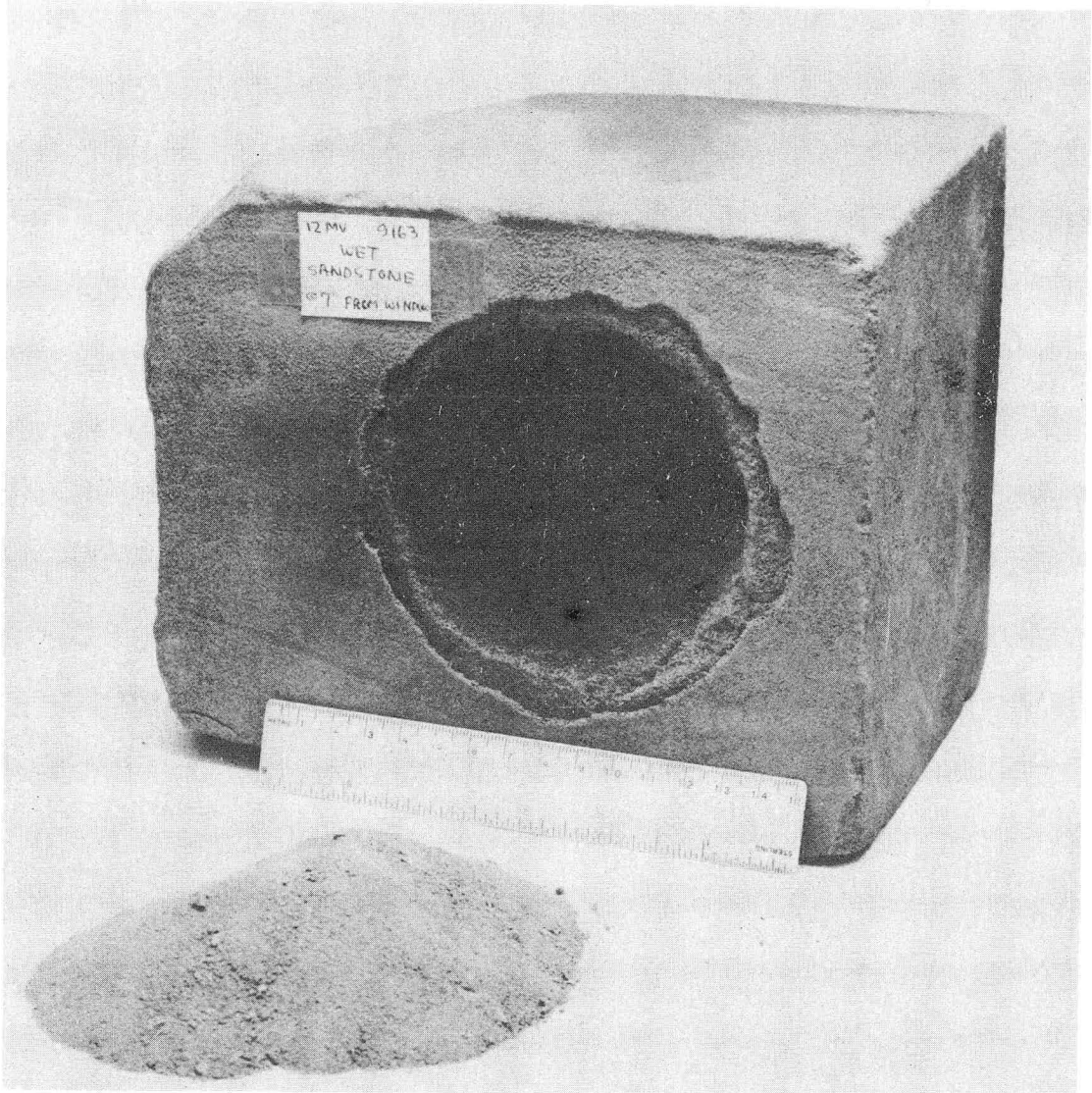

CBB 741-342

Fig. 1a - SANDSTONE (compr. strength = 6,200 psi) Spalling produced by bombardment with a single pulse of electrons (9 MV, 45 kA, 0.16  $\mu$ s = 64 kJ).



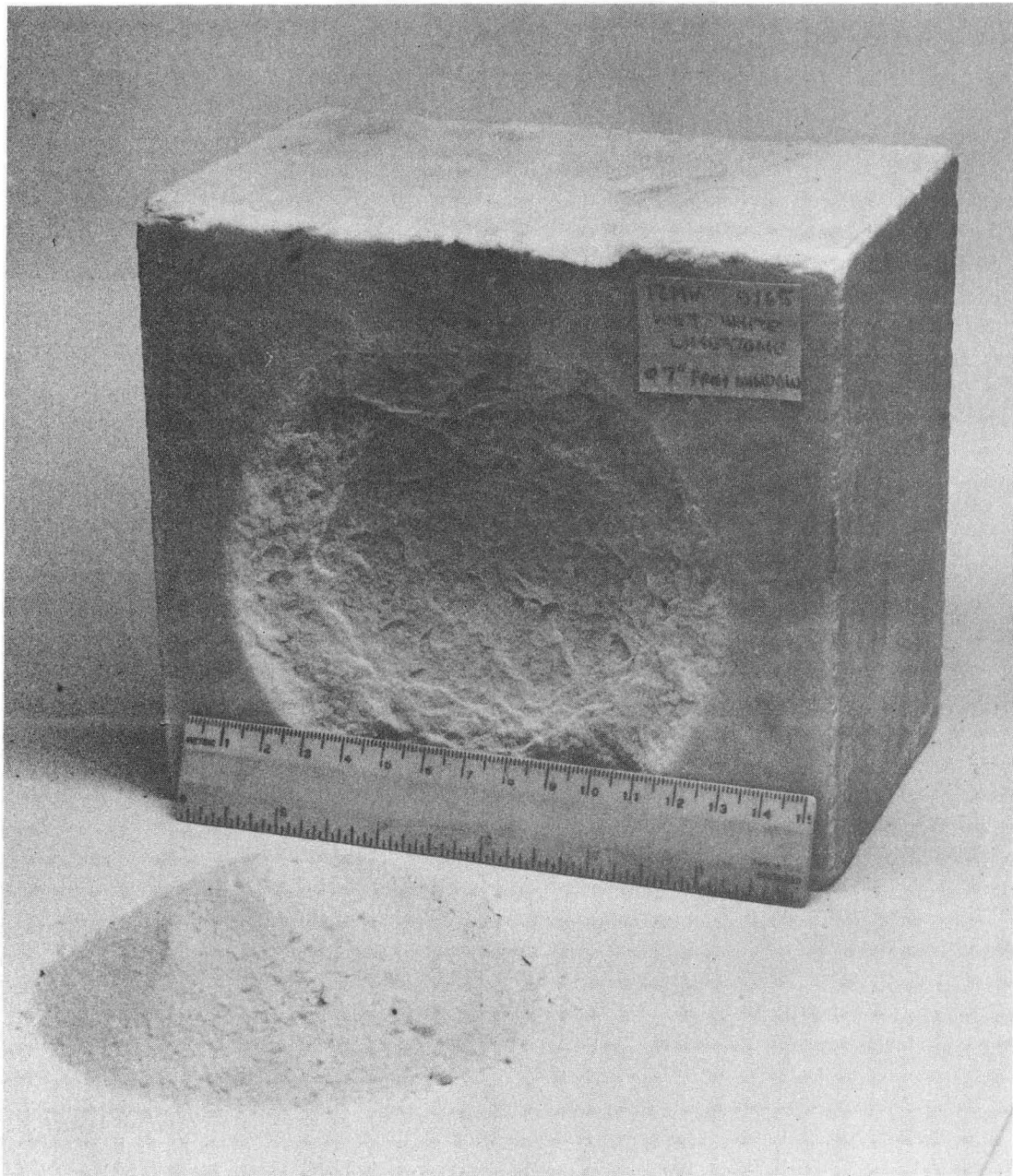

CBB 741-340

Fig. 1b - LIMESTONE (compr. strength = 8,400 psi) Spalling produced by bombardment with a single pulse of electrons (9 MV, 45 kA, 0.16  $\mu$ s = 64 kJ).

00004401604

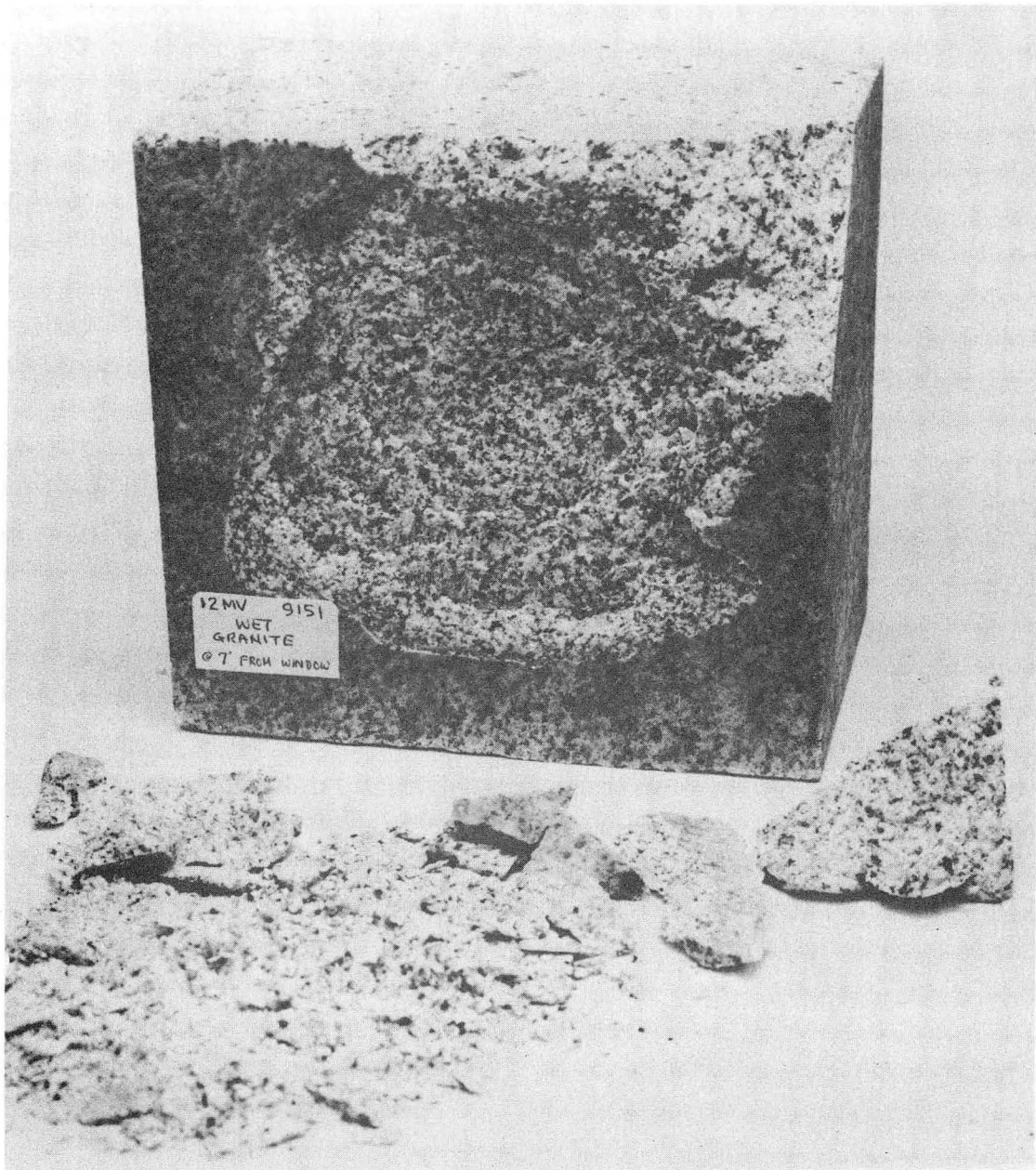

CBB 741-335

Fig. 1c - GRANITE (compr. strength = 26,000 psi) Spalling produced by bombardment with a single pulse of electrons (9 MV, 45 kA, 0.16  $\mu$ s = 64 kJ).

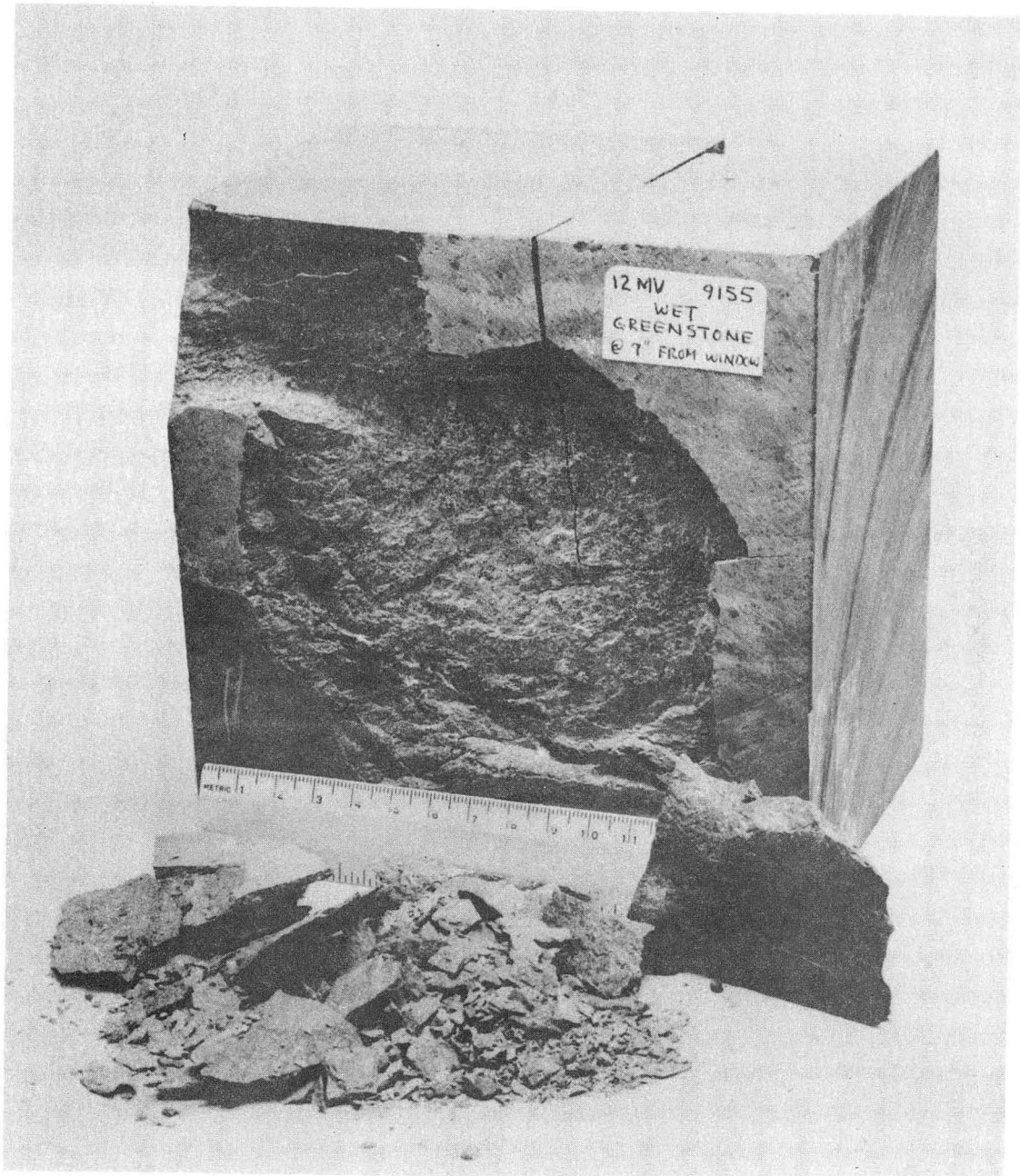

CBB 741-344

Fig. 1d - GREENSTONE (compr. strength = 40,000 psi) Spalling produced by bombardment with a single pulse of electrons (9 MV, 45 kA, 0.16  $\mu$ s = 64 kJ).

00004401605

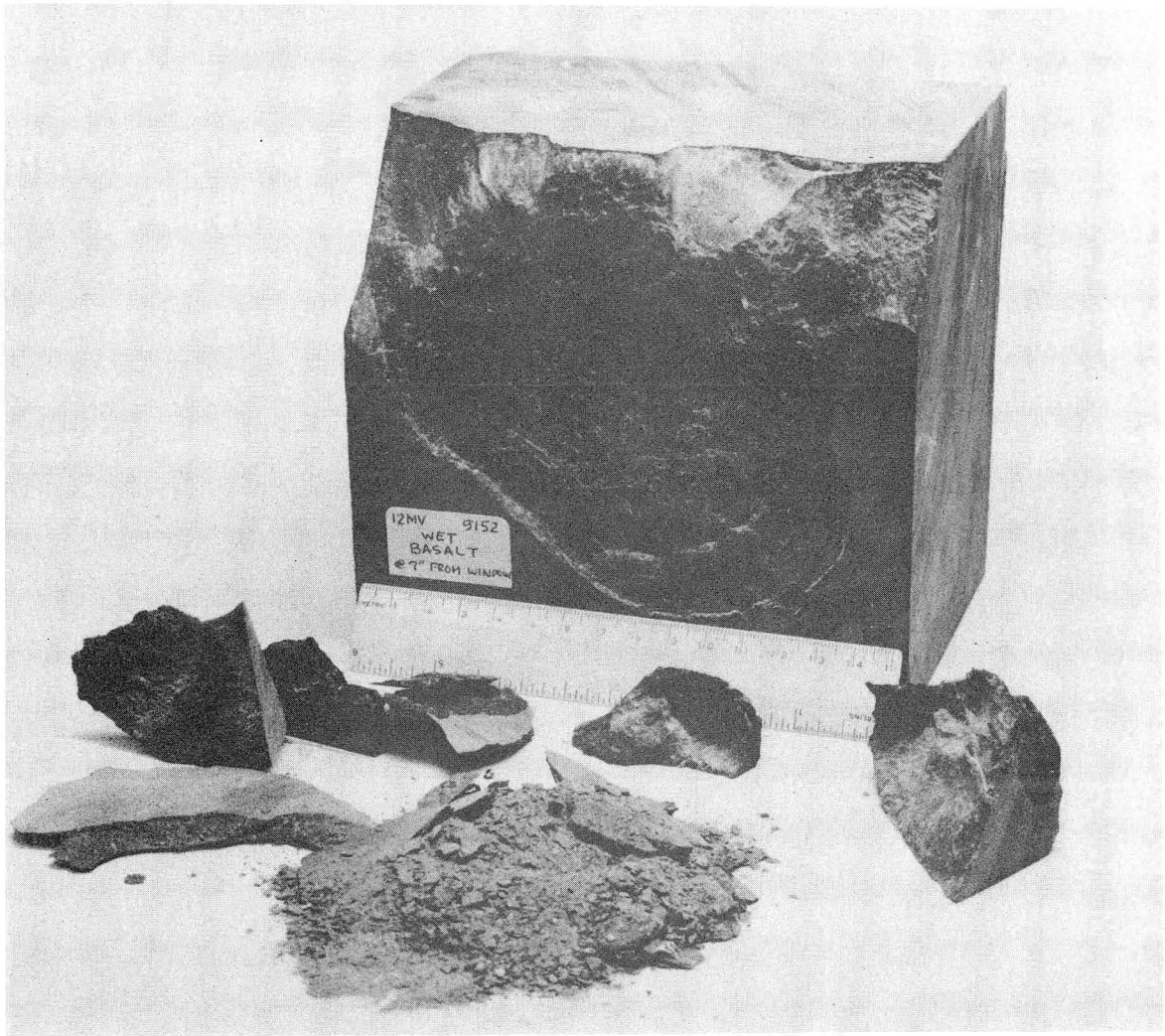

CBB 741-337

Fig. 1e - BASALT (compr. strength = 46,000 psi) Spalling produced by bombardment with a single pulse of electrons (9 MV, 45 kA, 0.16  $\mu$ s = 64 kJ).

00004401606

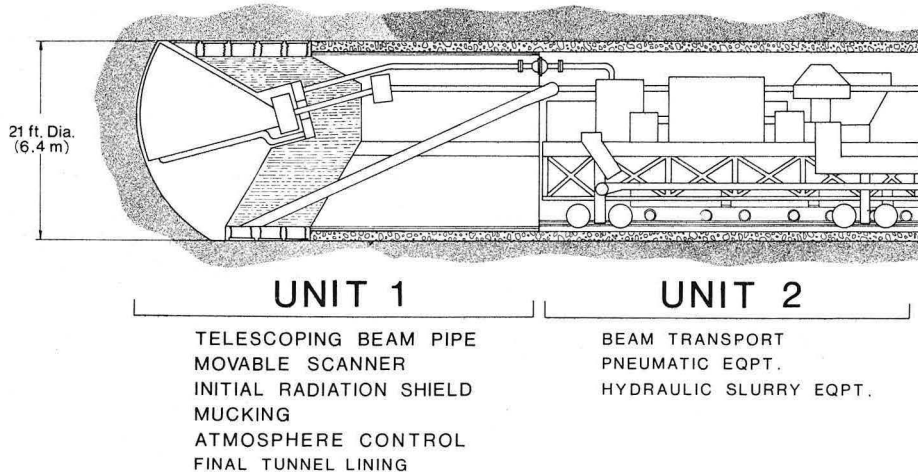

XBL 753-712

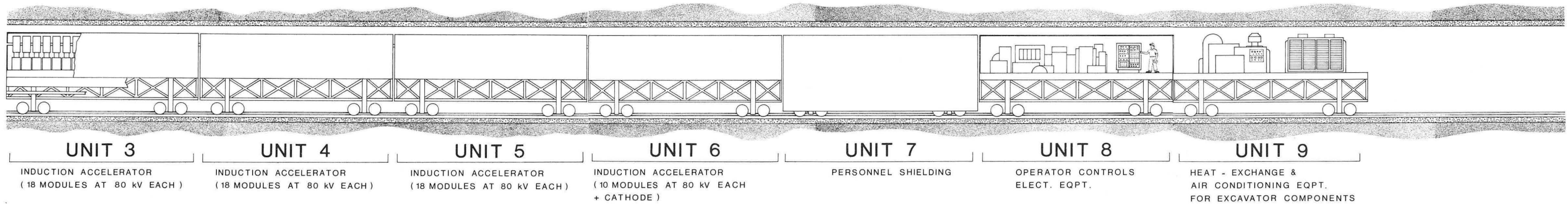

XBL 753-713

Conceptual example of a Pulsed Electron Tunnel Excavator capable of advancing a 21-foot (6.4m) diameter tunnel through hard rock at 10.6 (3.2m) per hour.

1044000

# ELECTRICAL BLOCK DIAGRAM

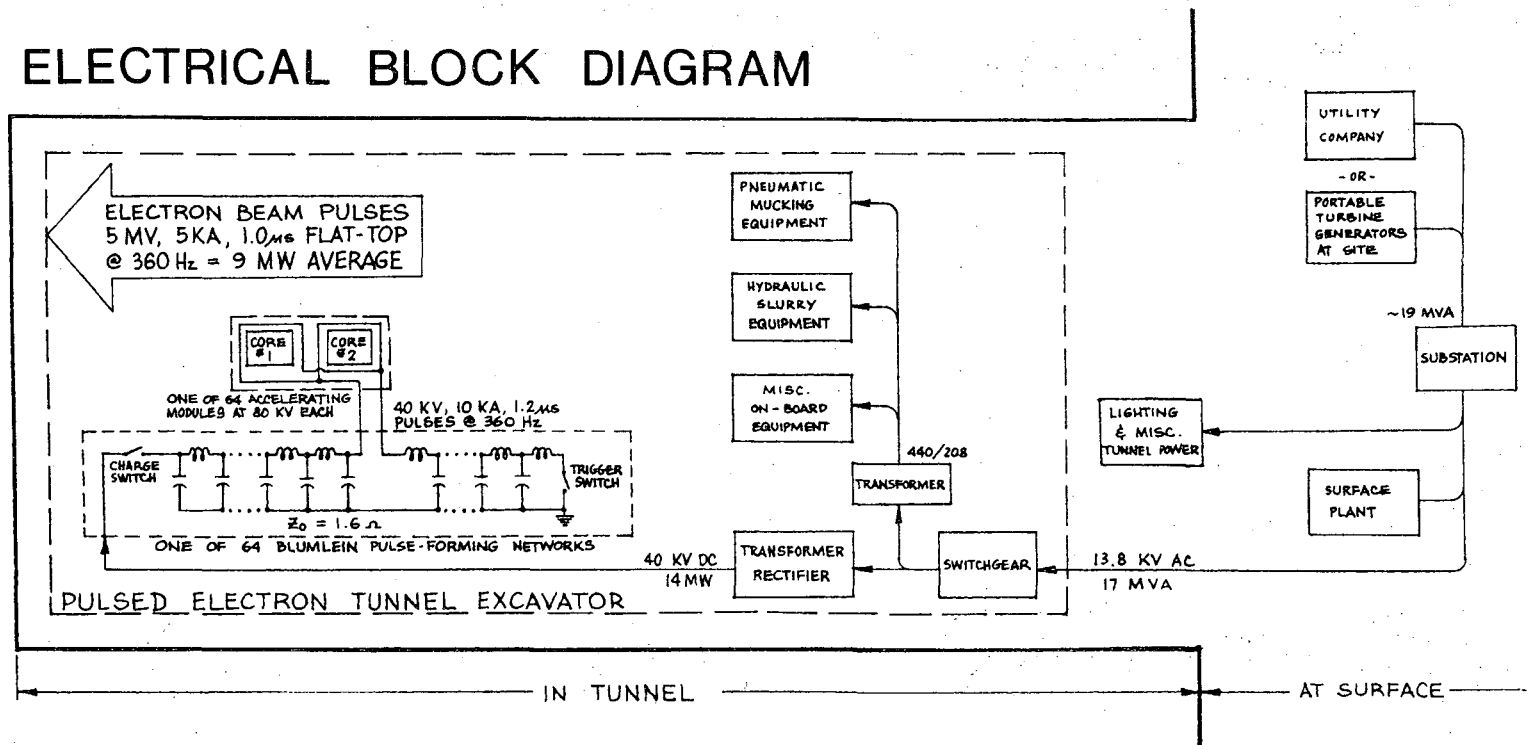
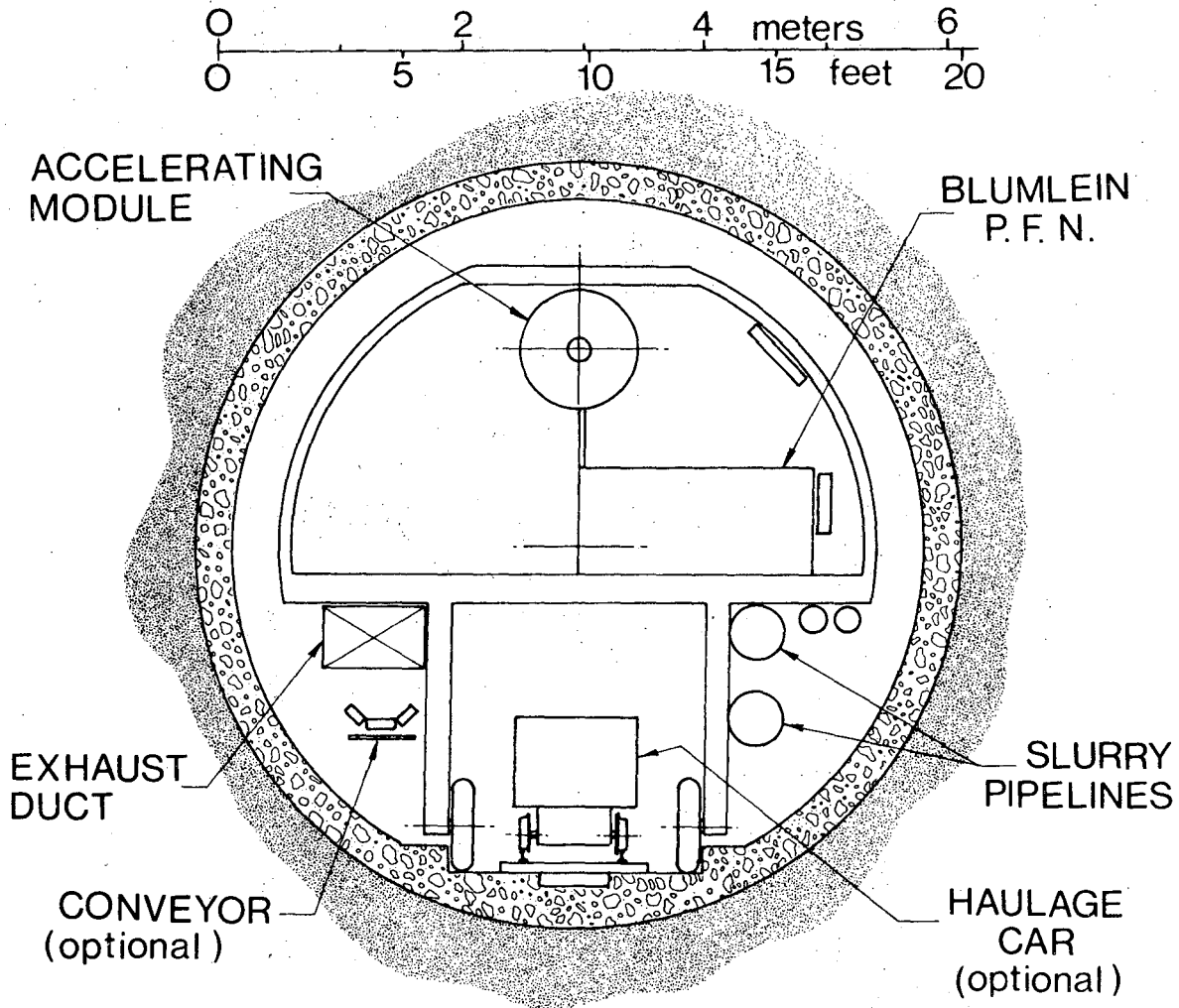

Fig. 3 - Electrical Block Diagram

XBL 753-518

00004401608





# TYPICAL SECTION AT ACCELERATOR UNIT

Fig. 4 - Cross-section through accelerating unit of Pulsed Electron Tunnel Excavator

XBL 753-555

0 0 0 4 4 0 1 6 0 9

SCHEMATIC OF ONE OF THE  
64 ACCELERATING MODULES

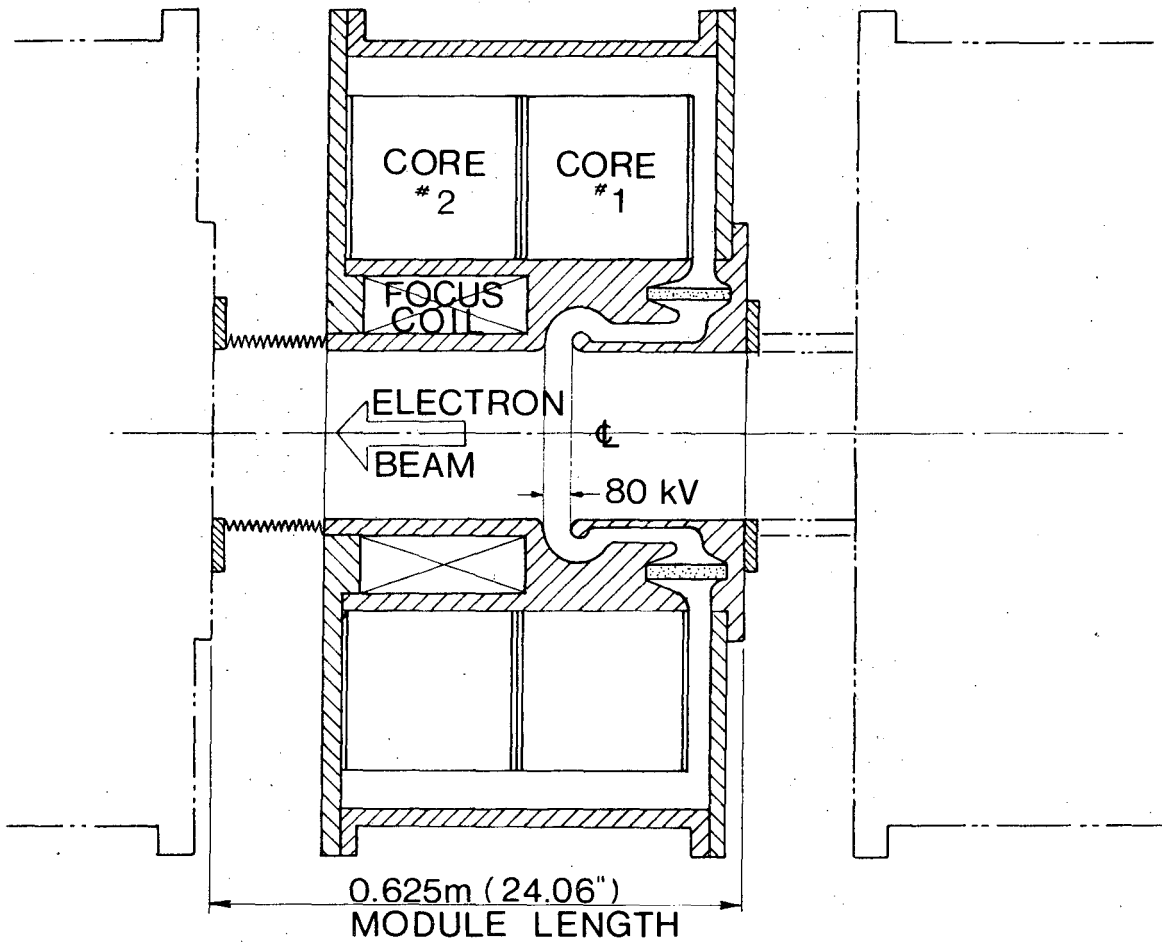

NBL 753-535

Fig. 5 - Schematic of one of the 64 accelerating modules.

00004401610

# MUCKING, AIR & WATER BLOCK DIAGRAM

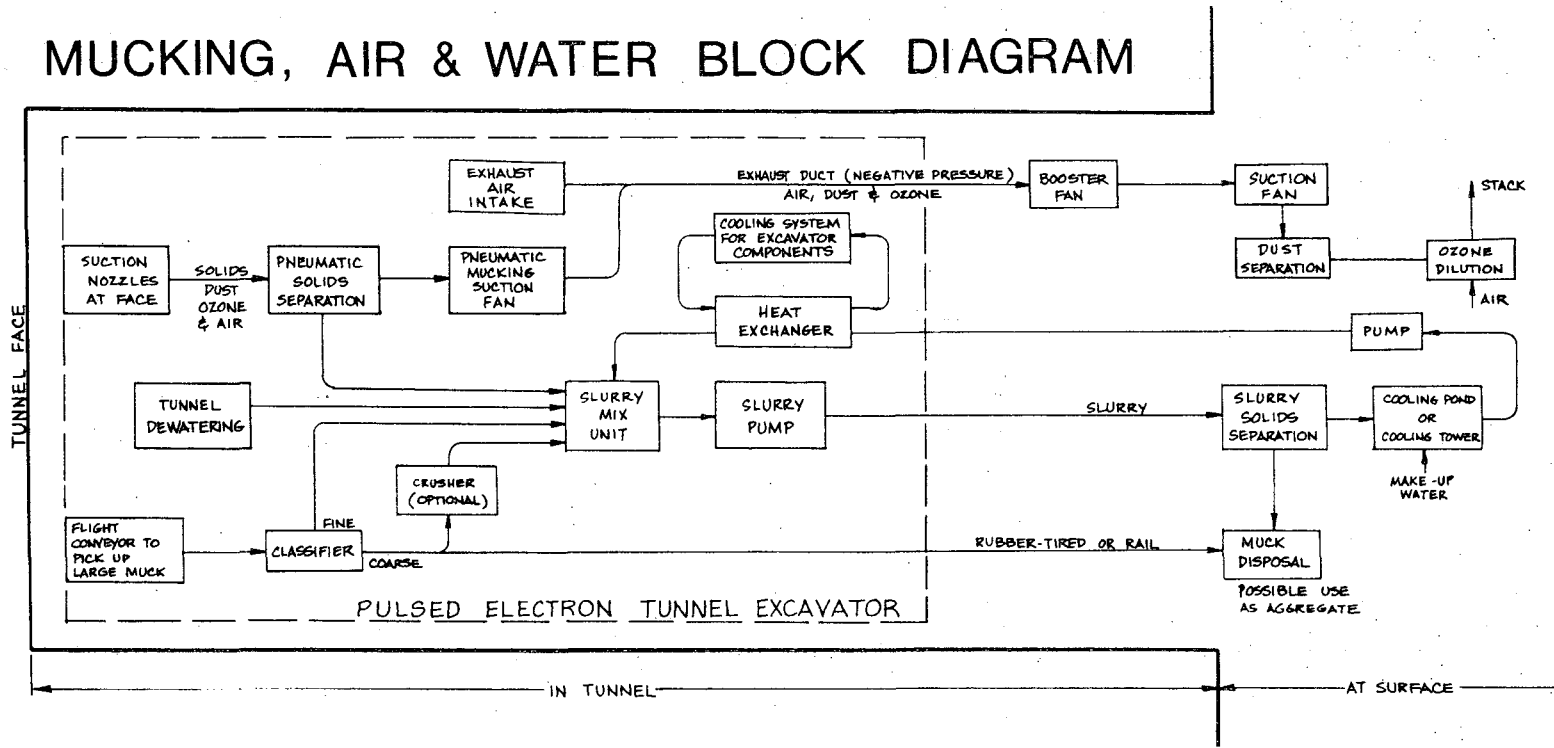

XBL 753-519

Fig. 6 - Mucking, air and water block diagram.

LEGAL NOTICE

*This report was prepared as an account of work sponsored by the United States Government. Neither the United States nor the United States Energy Research and Development Administration, nor any of their employees, nor any of their contractors, subcontractors, or their employees, makes any warranty, express or implied, or assumes any legal liability or responsibility for the accuracy, completeness or usefulness of any information, apparatus, product or process disclosed, or represents that its use would not infringe privately owned rights.*

TECHNICAL INFORMATION DIVISION  
LAWRENCE BERKELEY LABORATORY  
UNIVERSITY OF CALIFORNIA  
BERKELEY, CALIFORNIA 94720