

# UC Berkeley

## Indoor Environmental Quality (IEQ)

### Title

Developing low-energy personal thermal comfort systems: design, performance, testing, and research methods.

### Permalink

<https://escholarship.org/uc/item/92h1p54j>

### Author

Fannon, David J

### Publication Date

2015-07-01

Peer reviewed

**Developing Low-Energy Personal Thermal Comfort Systems: Design, Performance  
Testing, and Research Methods**

by

David Joseph Fannon

A thesis submitted in partial satisfaction of the  
requirements for the degree of  
Master of Science

in

Architecture

in the

Graduate Division

of the

University of California, Berkeley

Committee in charge:

Professor Gail Brager, Chair  
Professor Edward Arens  
Professor Alice Agogino

Summer 2015

The thesis of David Joseph Fannon, titled Developing Low-Energy Personal Thermal Comfort Systems: Design, Performance Testing, and Research Methods, is approved:

Chair \_\_\_\_\_  
\_\_\_\_\_  
\_\_\_\_\_

Date \_\_\_\_\_  
Date \_\_\_\_\_  
Date \_\_\_\_\_

University of California, Berkeley

**Developing Low-Energy Personal Thermal Comfort Systems: Design, Performance  
Testing, and Research Methods**

Copyright 2015  
by  
David Joseph Fannon

For Leah. For everything.

# Contents

<b>List of Figures</b>	<b>v</b>
<b>List of Tables</b>	<b>vii</b>
<b>1 Preface</b>	<b>1</b>
1.1 Research Context . . . . .	1
1.1.1 Thermal Comfort . . . . .	1
1.1.2 Comfort in Buildings . . . . .	2
1.1.3 Personal Comfort Systems . . . . .	3
1.1.4 Energy Use In buildings . . . . .	4
1.1.5 Low-energy PCS . . . . .	5
1.1.6 Simulated Energy Savings . . . . .	6
1.1.7 PCS Field Studies . . . . .	6
1.2 Research Problem . . . . .	9
1.3 Research Goal . . . . .	9
<b>2 Cooling Fan</b>	<b>10</b>
2.1 Fan Background, Problem, and Objective . . . . .	10
2.2 Concept Development . . . . .	10
2.3 Fan Design . . . . .	13
2.3.1 Fan Selection . . . . .	13
2.3.2 Cowling Design . . . . .	16
2.3.3 Wind Tunnel Testing . . . . .	16
2.3.4 Family Tree . . . . .	25
2.4 Human Interface . . . . .	26
2.4.1 Woodie . . . . .	26
2.4.2 Controls . . . . .	27
2.5 Performance Testing . . . . .	29
2.5.1 Intro to CFE . . . . .	29
2.5.2 Method . . . . .	30
2.5.3 Results . . . . .	37

2.5.4	Discussion . . . . .	40
2.5.5	Outcome . . . . .	44
2.6	Final Design . . . . .	44
2.6.1	Electrical Design . . . . .	44
2.6.2	Plastic Parts and molds . . . . .	47
<b>3</b>	<b>Footwarmer</b>	<b>50</b>
3.1	Footwarmer Background, Problem, and Objective . . . . .	50
3.2	Form and Function . . . . .	51
3.3	Housing and Manufacturing . . . . .	54
3.4	Electronics . . . . .	59
<b>4</b>	<b>Conductive Surface</b>	<b>63</b>
4.1	Surface Background, Problem, and Objective . . . . .	63
4.2	Design Concept and Testing . . . . .	64
<b>5</b>	<b>Combined CBE Personal Comfort System</b>	<b>69</b>
5.1	System Background, Problem, and Objective . . . . .	69
5.2	System design . . . . .	69
5.3	Fabrication . . . . .	72
5.3.1	Production . . . . .	72
5.3.2	Calibration . . . . .	72
5.4	Field Study Methods . . . . .	78
5.4.1	Objective . . . . .	78
5.4.2	High Throughput Research . . . . .	79
5.4.3	Procedure . . . . .	79
5.4.4	Human Subjects Protections . . . . .	86
5.4.5	Data Management . . . . .	87
<b>6</b>	<b>Conclusion</b>	<b>99</b>
6.1	Research Outcomes . . . . .	99
6.2	Future Work . . . . .	99
6.2.1	Widen Distribution . . . . .	99
6.2.2	Improving the Design . . . . .	100
6.2.3	Improving the research method . . . . .	101
6.2.4	Future Integration . . . . .	102
	<b>References</b>	<b>104</b>
	<b>Appendix A Fan Specification</b>	<b>108</b>
	<b>Appendix B Consent Form</b>	<b>115</b>

<b>Appendix C</b>	<b>Contact Information Form</b>	<b>118</b>
<b>Appendix D</b>	<b>Personal Information Questionnaire</b>	<b>120</b>
<b>Appendix E</b>	<b>Information Technology Guide</b>	<b>122</b>



# List of Figures

1.1	Energy savings from expanded setpoints	7
2.1	Fan 1.0 CAD Assembly Drawing	11
2.2	Renderings of fan version 1.0	12
2.3	Early motor and propeller components	14
2.4	Cowling options for airstream testing	18
2.5	Symbols and Notation in the Jet Model	19
2.6	Measuring air speed	21
2.7	Spatial distribution of air velocities	22
2.8	Air velocities for inlet and nozzle combinations	23
2.9	Fan 2.4 Fankenstein	24
2.10	Fan Family Tree of prototypes	25
2.11	Fan 3.0 initial CAD design	27
2.12	Filmstrip of Fan 3.0 "Woodie"	28
2.13	Fabricating Fan 3.0	28
2.14	Experimental setup for CFE measurement	31
2.15	HVAC Temperatures during CFE measurement	36
2.16	Comparison of Cooling Fan Efficiency	39
2.17	Local cooling effects during CFE measurement	41
2.18	Cooling Fan Efficiency plotted as a function of power	42
2.19	Visible and IR photos of the thermal manikin during CFE testing	43
2.20	Illustrated fan circuit diagram	46
2.21	Early and final electronic wiring for the fan	47
2.22	Mold Flow Analysis	48
3.1	Sections showing geometry of lamps in footwarmers	51
3.2	Fabricating the elliptical footwarmer	52
3.3	Elliptical footwarmer in use	53
3.4	Visible and IR images of the footwarmer	54
3.5	Cardboard Footwarmer Mockup	55
3.6	Sheet Metal Footwarmer Prototype	56

3.7	Footwarmer CAD design . . . . .	57
3.8	Footwarmer CAD design . . . . .	58
3.9	Fabricating the footwarmer . . . . .	60
3.10	Wiring diagram for the footwarmer . . . . .	61
4.1	Prototype integrated palm warmer . . . . .	63
4.2	Prototype desks featuring conductive surfaces . . . . .	65
4.3	Prototype conductive desk surfaces . . . . .	66
4.4	2d analysis of heat transfer by conduction . . . . .	67
5.1	Personal Comfort System . . . . .	70
5.2	Bench for low-voltage assembly . . . . .	73
5.3	Arrangement of High Bay space for production . . . . .	74
5.4	Calibrating fan version 4.3 . . . . .	75
5.5	Results from calibrating a sample of 13 fans . . . . .	77
5.6	PEC installation at study site . . . . .	81
5.7	A new PCS user offers feedback . . . . .	82
5.8	PEC user information card . . . . .	84
5.9	PEC Data management diagram . . . . .	88
5.10	Diagram of datasets linked by a shared code value . . . . .	90
5.11	Diagram of datasets linked by a keyMap file . . . . .	90

# List of Tables

2.1	Specifications for computer fans . . . . .	15
2.2	Inlet and outlet design combinations . . . . .	20
2.3	Properties of the fans tested for Cooling Fan Efficiency . . . . .	30
2.4	Body parts and areas of the thermal manikin . . . . .	33
2.5	Test conditions for Cooling Fan Efficiency . . . . .	34
2.6	Fan power for Cooling Fan Efficiency measurement . . . . .	38
2.7	Cooling Fan Efficiency . . . . .	38
4.1	Conductive surface simulations . . . . .	68
5.1	Fan calibration test conditions . . . . .	76

## Acknowledgments

Many people helped make this thesis possible. My committee: Gail Brager offered endless patience and unfailing support. Professor Alice Agogino agreed to take on a little fan that turned into a big project. Ed Arens' knowledge, curiosity, and excitement for learning were an inspiration and a guide.

Ryan Luecke's work, from circuit design to database programming, made the vision of PersonalComfort Systems a reality. Neither this thesis nor the CBE Personal Comfort System would exist without his effort. The use of "we" in the text generally refers to the research team of Professor Ed Arens, Hui Zhang, Ryan Luecke and I.

This research was supported by a grant from the California Energy Commission, and by the Center for the Built Environment.

It was a privilege and a pleasure to undertake this research in the community of CBE. I am greatly indebted to Stefano Schivon for his help with the manikins, calibration statistics, and many walks home. Wilmer Pasut assisted with the calibration of temperature sensors and the operation of the environmental chamber. Yongchao Zhai shared a chilly office and encouraging thoughts. Fred Bauman and Tom Webster each offered their insight, humor, and experience. Among my fellow students, Katie Ackerly sketched the data management diagram, Lindsay Baker fostered an environment of constant support and encouragement, David Heinzerling helped with CBE servers, and Brian Coffee had many thoughtful conversations and introduced me to the faculty club lunch. Many others at CBE and the Center for Environmental Design Research provided logistical and administrative support, especially Vicky Garcia, David Leherer, and Kira Abrams.

I owe a great deal, only partially repaid in frozen yogurt, to the volunteers whose long hours, nimble fingers and diligent efforts helped assemble our hundred research units. Particularly Ian, Jason, Grace, Ashley, Isariya, Will, Yalena, Megan, and Soazig.

Larry, Jamie and Frank in the Berkeley Architecture Fabrication shop lent their insight to the construction of prototypes, and their wisdom to the repair of the soul. Professor Paul Wright, Dan Chapman, Andrew Watterbury and Chris Sherman of the Berkeley Manufacturing Institute provided invaluable resources and expertise in the early prototyping. Engineering students Spencer Lin and Douglas Fabini provided hours of design and development effort. The team at West Coast Fab, especially Amador, brought decades of experience and weeks of careful labor to fabrication.

In the School of Architecture, Cris Benton's avuncular charm and pointed questions about disposable artifacts led me to create Woodie. Susan Ubbelohde's words and example continue to inspire and instruct. Lois Koch calmly resolved every policy and paperwork problem from admission to graduation. My committee of peers, Alison, Jeremy, Eliana and Anna, saw me through everything from ARCH-281 through final edits.

Above all, I could not have done this without Leah, to whom my debt exceeds words.

# Chapter 1

## Preface

### 1.1 Research Context

This project—developing, testing, and preparing to field-test the Center for the Built Environment’s low-energy Personal Comfort System—grows out of many threads developed over decades of research and development. As such, the background outlines the following topics: human thermal comfort and physiology, the energy-saving potential of using increased air movement for cooling, and the comfort and productivity benefits when individuals control their thermal environment.

#### 1.1.1 Thermal Comfort

ASHRAE standard 55 defines thermal comfort as “...that condition of mind which expresses satisfaction with the thermal environment.” (ASHRAE, 2004). In most buildings, this “condition of mind” is supposed to be created by building-scale systems of HVAC equipment that deliver particular conditions of temperature, humidity and airflow to the occupied spaces, in hopes that they will affect people sufficiently to create thermal comfort. Personal Comfort Systems, on the other hand, seek to provide localized comfort for individuals, rather than conditioning whole spaces, which promises to increase occupant satisfaction while reducing energy consumption, and stands as something of a critique of the methods assumed in standards like ASHRAE 55. Critics of these standards may point out that common models of human thermal comfort, such as Fanger’s Predicted Mean Vote (PMV) model that underlies the ASHRAE standard, are based on homogenous and steady-state conditions (Fanger, 1970), which do not apply to non-uniform, local thermal conditioning. Previous authors, including Bohm et al. (1990); McGuffin et al. (2002); Wyon et al. (1989) used the Equivalent Homogenous Temperature (EHT) method to characterize non-uniform environments. The work of Zhang et al. (2004) in part served to expand the data available for EHT, and support the development of the thermal model described by

McGuffin et al. (2002).

Conditioning for comfort can be localized further, to the scale of individual parts of the body. The relative influence of individual body parts on overall thermal comfort or even thermal pleasure has been a subject of ongoing investigations, for example (Attia and Engel, 1981; Cabanac, Massonnet, and Belaiche, 1972; Mower, 1976; Zhang, 2003; Zhang et al., 2004, 2010b). Zhang et al. (2004) performed over one hundred tests in which individual portions of the body were isolated, and heated or cooled even as the surrounding environment was independently warm, cool or neutral. The major findings emphasize the importance of the extremities (e.g. hands, feet, face, neck) in providing for thermal satisfaction and even pleasure in conditions where the body is otherwise uncomfortable. Cabanac, Massonnet, and Belaiche (1972) observe that there are probably good physiological reasons for this, noting,

“Finally, pleasure appears to be an efficient motivation for an efficient behavior, since one hand immersed in stirred water at 20° C (very pleasant) can drain as much heat as 1 met in a hyperthermic man. This circumstance verifies the statement, pleasant = useful.” (ibid.)

This work suggests wide-ranging implications for understanding human thermal comfort, and prompts new, more sophisticated models for assessing and simulating it, for example Huizenga, Zhang, and Arens (2001); Parkinson and Dear (2014); Zhang et al. (2010b,c,d). These models, in turn, lay the groundwork for the development of devices and systems that use highly-localized and therefore very low-energy conditioning approaches to providing thermal comfort. Rather than condition a whole building, or area, or even an entire workstation, it is possible to achieve comfort by conditioning individual parts of the human body.

### 1.1.2 Comfort in Buildings

The past half century has witnessed the enormous growth in the number of so-called “information workers” who produce or use data (Wolff, 2005), and work in offices rather than farms or factories. This shift spurred major changes to the design, construction and operation of office buildings and brought new attention to the importance of office ergonomics—the systematic design of the job and environment to fit individual workers—to ensure their wellbeing and productivity (Wilson, 2000). Kroemer (2001) clearly expresses this idea that systems and artifacts should adapt to people rather than the reverse, noting, “ergonomics focuses on the human as the most important component of the office and adapts the office to the people involved.” While advances in software, furniture and office design have improved the ergonomics of the virtual and physical environments by making them human-centered, the prevailing model for the thermal environment and for air quality remains one of idealized uniformity and central conditioning (Arnold, 1999a).

In fact, some of the technologies that accompanied these changes in the modern workplace, such as sealed buildings and centralized mechanical conditioning, may be inimical to occupant well-being.

In some ways, this shift is only the latest manifestation of a trend that emerged as a result of the growth of commerce in the late 19th century and led directly to the advent of the office as a building type. Arnold traces the evolution of the modern office building, focusing on the strategies used to provide ventilation and thermal comfort. Banham (1984) outlines a similar pattern as he traces the history of Heating and Cooling in buildings.

Surveys of Indoor Environmental Quality (IEQ) in modern offices show many workers find these aspects of buildings unsatisfactory. A large survey by Huizenga et al. (2006) found more occupants reporting dissatisfaction (42%) than satisfaction (39%) with their thermal environment. Furthermore, the researchers found that in only eleven percent of the buildings were eighty-percent or more of the occupants satisfied with the temperature. The researchers did not choose the eighty-percent satisfaction rate arbitrarily; the applicable standard at the time of the study, ASHRAE (2004), stipulates that the percentage of the population expressing dissatisfaction with their thermal environment should not exceed 20%, and specifies physical criteria believed to achieve that. However, survey results for real buildings around the world indicate that almost 90% of buildings surveyed do not meet this standard; leading Huizenga et al. to conclude that “With respect to thermal comfort and air quality performance goals set out by standards, most buildings appear to be falling far short.” Frontczak et al. (2012) analyzed the results of nearly fifty-three thousand surveys of office workers in 351 office buildings over a ten-year period. Of the seventeen parameters considered, four (Air Quality, Noise Level, Temperature and Sound Privacy) had median scores of neutral or below, with mean scores for temperature and sound privacy actually indicating dissatisfaction.

### 1.1.3 Personal Comfort Systems

There are numerous potential advantages to providing users with individual control of their highly-local thermal environment<sup>1</sup>. First and perhaps most important, it offers people the ability to adjust the thermal environment based on their needs and preferences.

---

<sup>1</sup>This approach and these devices have many names, and the nomenclature has evolved over time. Some examples include Personal Environmental Control (PEC), Task Ambient Conditioning (TAC), Personal Comfort Systems (PCS), and Personal Ventilation (PV), as well as proprietary product names, such as the Personal Environmental Module. The term “Personal Comfort Systems” or the acronym PCS is used throughout the body of this document when describing the system as a whole, in particular in relation to devices developed as part of this research project. However, where references use different terms, the original language is preserved and differences are noted. Similarly, some of the supplementary materials that appear in the appendix, such as the specifications and IT Guide, were originally released using the term “Personal Environmental Control” and are therefore not modified. Finally, where variable, parameter, and file names were developed using other terminology, they are generally preserved to ensure consistency with existing code and documentation, for example “pecID” and “pecDistributionList.xls”.

This ends disputes over the space conditioning and allows rapid and personal adjustments based on season, time of day and personal preference. This also promises to increase the range of ambient conditions in which people achieve thermal comfort and potentially reduce energy consumption for whole-space conditioning. Alternatively, this increased deadband would ameliorate the effects when HVAC systems shut down under a demand-response regime on peak electric usage days. In mostly passive buildings, a low-energy local comfort system could shave off thermal peaks or valleys that may occasionally occur. Strategies like night-time pre-cooling may result in morning conditions that are too cool for some occupants, a problem personal systems could address. Similarly, natural ventilation may be insufficient for some users on peak heating days, and a local increase in cooling might be sufficient to keep users comfortable during those times.

Generally speaking, these personal comfort devices are small and self-contained, so they are easy to retrofit into existing buildings to address comfort concerns or support a lower-energy retrofit. They require no pipes, ducts, shafts, equipment rooms or other space allocations, so they are quite compatible with historic buildings that operated passively and have no provision for these services. The systems are inexpensive, and provide some degree of redundancy or resilience for building comfort conditioning.

While the first efforts to study local control and personal comfort took place in laboratories, limited field studies demonstrate the promise of comfort outside the lab as well. As one part of a wider field study, Bauman et al. (1998) found that control over air movement reduces sensitivity to temperature increases by a factor of two. Arens et al. (2011) found that low-energy Personal Comfort Systems are a fruitful topic for further research, noting, “there remain practical questions about how PECS might be perceived by occupants over time in a real office environment”<sup>2</sup>. This research sets the stage to investigate those issues. In developing prototypes, draft specifications and protocols for testing the devices, this research seeks to remove barriers to industry adoption of the personal comfort approach by comparing building energy consumption and occupant satisfaction for office workers using local low-energy thermal controls with those limited to conventional conditioning.

### 1.1.4 Energy Use In buildings

Unfortunately, buildings require a tremendous amount of energy to achieve even the modest levels of thermal satisfaction described above. Commercial buildings expend enormous amounts of energy on heating, cooling and ventilation, some 7.23 quadrillion Btu (quads) of energy annually in the United States according to US Department of Energy (2011, table 3.1.4). That sum represents about one forty-percent of the 18.26 quads of primary energy used in commercial buildings in the US each year, which in turn comprises an

---

<sup>2</sup>Note this reference uses the term “Personal Environmental Control Systems” hence the abbreviation “PECS”.



18.9% (and growing) slice of the nationwide primary energy consumption<sup>3</sup>. Put another way, heating, cooling, and ventilating commercial buildings in the US represents approximately 1.5% of the world's total annual primary energy consumption of 479.921 quads (US Department of Energy Energy Information Agency, 2010). That means that in the US, commercial-building HVAC alone uses more energy than most countries, and is roughly on par with the total energy consumption of Italy. These are not just staggering numbers in abstract: the greenhouse gas emissions associated with using all this energy are directly linked to global climate change. According to the US Department of Energy, powering commercial buildings in the United States costs over \$400 billion each year (*Better Buildings Department of Energy*). And all to achieve levels of thermal satisfaction somewhere between fair and middling.

### 1.1.5 Low-energy PCS

In a comprehensive human subjects test, Zhang et al. (2010a) brought together the threads of individual thermal comfort, direct personal control, and targeted conditioning of individual body parts into a single laboratory study. This research tested the same mechanisms of cooling only by air movement and heating by radiant exchange ultimately adopted for the CBE Personal Comfort System design, and as such stands as the direct experimental forebear of the PCS development.

The study tested what was then called a Task-Ambient Conditioning system with four components: a conductive hand warmer and a radiant foot warmer for cool conditions, and a head-directed vent and a conductive hand-cooler for warm conditions. Critically, these devices were designed to consume very little energy, with peak electrical consumption of 41 W in cooling mode, and steady-state heating consumption of 59 W (*ibid.*). The system was placed in a controlled environmental chamber capable of producing a wide range of temperature conditions, and eighteen subjects each experienced five conditions, for a total of ninety tests. The test protocol included degrees of personal control over the TAC system. To evaluate the effects of the various conditions the subjects responded to subjective comfort surveys, and also performed objective tasks designed to measure logical thinking, mental performance, and manual dexterity.

The study found subjects with a TAC system reported thermal sensations of neutral or only slightly warm or cool even when exposed to a large air temperature range, from 18° C to 30° C. Similarly, using the TAC system allowed the users to achieve thermal comfort in all but one of the ninety tests. These findings using low-power devices in an environmental chamber confirmed the theoretical promise of both increased comfort and energy savings—at least in a laboratory setting. The authors also observed that the non-uniform thermal environment caused by localized conditioning of individual body parts increased comfort and, in some cases, productivity. The authors went on to simulate the energy im-

---

<sup>3</sup>All based on 2010 data, which is the most recent year available.

plications of widely deploying the system in office buildings in three sample climates, and found total HVAC energy savings on the order of 30% thanks to the expanded deadband.

### 1.1.6 Simulated Energy Savings

Computer simulations of the effect of expanded temperature set-points (increased deadband) when using local thermal control systems in various climates estimate significant potential savings for heating and cooling energy, so long as the personal comfort system itself consumes relatively little energy (e.g. Hoyt et al., 2009; Hoyt, Arens, and Zhang, 2014; Schiavon and Melikov, 2009a; Schiavon, Melikov, and Sekhar, 2010). These results can best be visualized using figure 1.1, which was created using data from (Hoyt et al., 2009). The upper portion of the diagram shows the percentage of heating and cooling energy saved in each of three climates for each expansion of the setpoint temperature range to warmer or cooler temperatures. This diagram not only highlights the significant energy savings possible from even modest increases in the comfort zone compared to a baseline, it also highlights the importance of climate for potential savings, with cold climates benefiting more on the heating side, and warm climates more on the cooling side. The bottom portion of the figure shows the relative size of the deadband ranges that might be achievable using conventional, adaptive and personal comfort-based conditioning strategies.

Hoyt et al. (2009); Hoyt, Arens, and Zhang (2014) observe that the expanded comfort zone not only saves energy because more hours of the year fall in the zone that requires no conditioning, but also the expanded temperature range reduces the temperature difference between outside conditions and the setpoint that systems must overcome when they are operating. Acknowledging that simulation results are good comparisons between models, not necessarily predictions of future behavior, the authors do offer a rule of thumb, estimating “The saving is about 10% for each degree Celsius increase or decrease in the setpoint.” (Hoyt et al., 2009, p. 4) Realizing these promised energy savings and optimal comfort will demand not only excellent personal comfort systems, but also changes to the operation, and possibly design, of buildings and their HVAC systems.

### 1.1.7 PCS Field Studies

In spite of the promising theoretical and laboratory results, personal comfort systems have not enjoyed widespread adoption in buildings, perhaps in part because of the risks and costs associated with implementing unproven technology. Certainly field studies would help assuage these concerns, but the few field studies of personal comfort systems generally focus only on occupant satisfaction, rather than energy savings or on changes to the operation of building heating and cooling systems.

Kroner and Stark-Martin (1994) set out to demonstrate improvements in worker satisfaction and productivity as a benefit of using the personal comfort approach, thus jus-

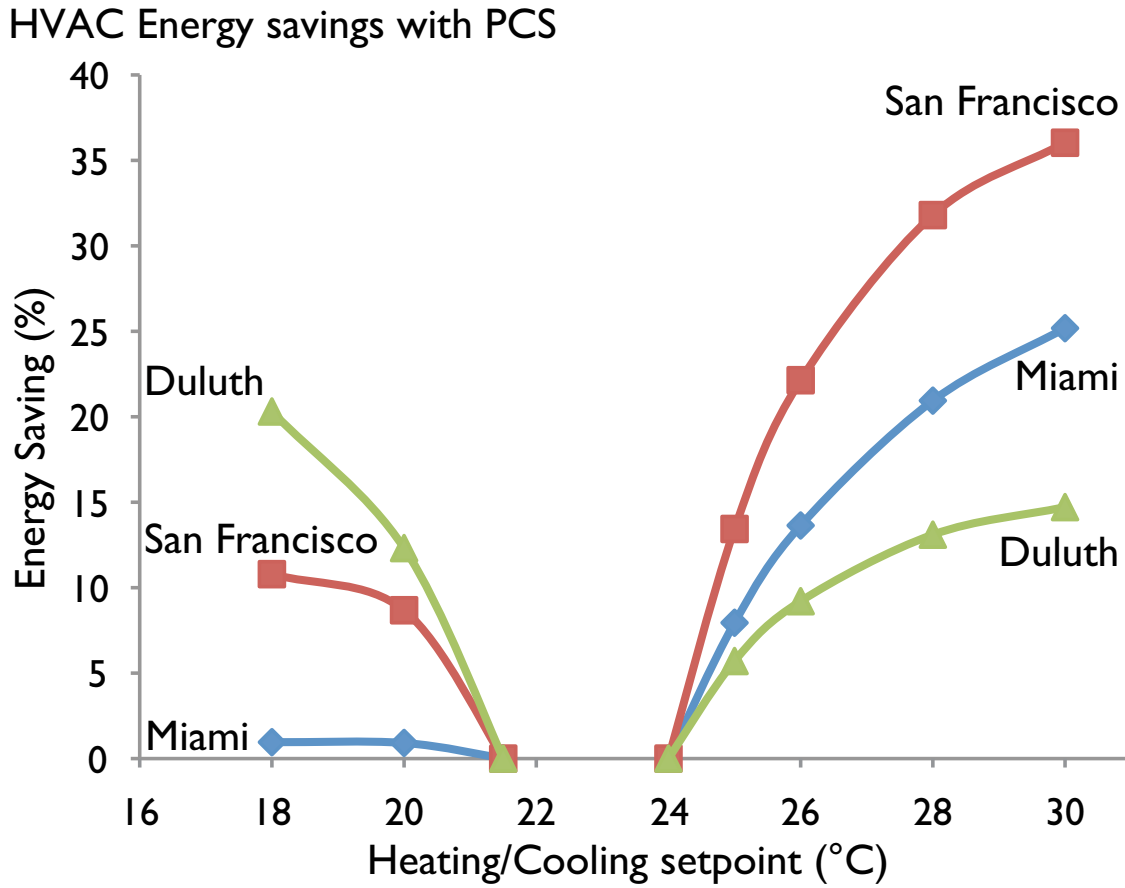

### Expanded comfort with PCS

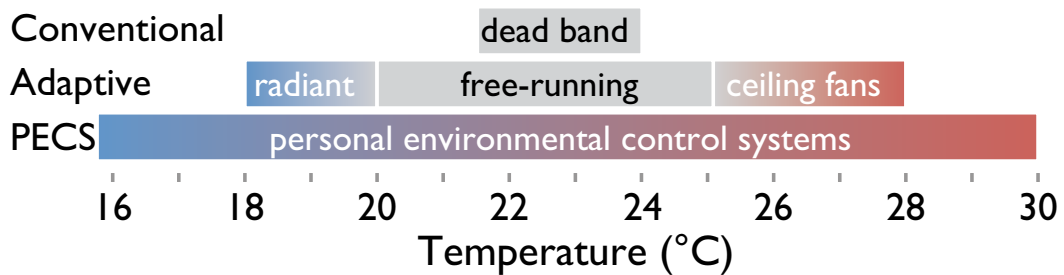

Figure 1.1: Simulated energy savings based on expanded set point temperature ranges for different climates. (Hoyt et al., 2009).

tifying the cost and ameliorating the risk. In their landmark West Bend Mutual Insurance study<sup>4</sup>, the researchers used both occupant surveys and a productivity measure already in place at the company to track workers over a year both before and after moving to a new building equipped with Johnson Controls Personal Environment Modules (PEM), which the researchers dubbed Environmentally Responsive Workstations (ERW). The study found a significant transient loss in productivity (~30%) during the move, and a significant gain after settling into the new facility (~16%). Recognizing that some of this gain could be attributed to other aspects of the new building or the move itself, the so-called Hawthorne effect, the researchers attempted to isolate the impact of the ERW from the move by selectively disabling the units for various employees. Unfortunately, the effect was compromised by subjects demanding their system be repaired immediately (Kroner, 2006), but based on their data, the researchers ultimately claim a 2% gain in productivity associated with the ERW. Perhaps more compelling than that figure is the anecdotal evidence that users refused to have their system remain deactivated. While the survey and anecdotes provide convincing evidence of increased satisfaction, and this study demonstrates an approach to the problems of quantifying productivity, it did not address energy use, and the operation of the central conditioning system was not adjusted.

A subsequent field study (also using the Johnson Controls PEM) in San Francisco offices did consider energy use, and adjusted the temperature setpoints for the central conditioning system to experiment with a broader range of ambient conditions. Bauman et al. (1998) found that occupants provided with personal comfort system found a broader range of ambient temperatures comfortable and reported higher overall satisfaction across all areas investigated<sup>5</sup>. This rigorous study included detailed group selection and survey design, extensive instrumentation and coupled “right now” surveys with real time measurement using a portable instrument cart. The subjects were surveyed and measurements taken prior to the installation of the system and again after it was installed. Furthermore, the researchers were able to manipulate the set point temperature of the office space to evaluate occupant comfort across a range of ambient temperatures. Finally, the control settings and use patterns of the PEM were monitored using a digital network. The researchers ultimately found that the individual thermal control capabilities of the units allowed a larger percentage of the workers who had a PEM to maintain comfortable conditions over a wider range of ambient temperatures than those in the control group.

More recently, Taub et al. (2015) deployed the heating component of the Personal Comfort System developed as a result of this research project for a field study of an office in northern California. The occupants were provided with footwarmers, and the setpoint temperatures for the space were reduced from 70°F to 66°F, with no significant changes to occupant comfort. Promisingly, the average power use was very low, averaging approx-

---

<sup>4</sup>The research was carried out in summer of 1991 and subsequently published as Kroner, 2006; Kroner and Stark-Martin, 1994.

<sup>5</sup>Because the PEM addresses more than thermal comfort, these areas include Thermal Quality, Air Quality, Lighting Quality, Acoustical Quality, Spatial Layout, and Office Furnishings.

imately 20 Watts during occupied hours: a reduction of over 90% compared to the power required for the central heating system.

## 1.2 Research Problem

The comfort and satisfaction benefits of PCS are well documented under laboratory conditions (Zhang et al., 2010a), and a handful of field studies to date (Bauman et al., 1998; Kroner and Stark-Martin, 1994) have found similar response in actual offices. On the energy side, extensive simulation (Hoyt et al., 2009; Hoyt, Arens, and Zhang, 2014; Schiavon and Melikov, 2009a; Schiavon, Melikov, and Sekhar, 2010) demonstrates that low-energy PCS can dramatically reduce the overall HVAC energy for buildings.

There are no personal comfort systems on the market and ready for deployment in offices which offer the enhanced satisfaction and energy savings. To demonstrate those promises requires developing new components into a PCS. Furthermore, the benefits from low-energy PCS, while thoroughly documented in the lab and by simulation have not been measured in field studies in real offices. Providing that evidence requires surveying users regarding their comfort, and measuring the operation of the PCS and energy consumption. Finally, a field study needs a protocol and method for gathering data and drawing conclusions. These three objectives would help realize the promise of PCS to increase occupant satisfaction while reducing energy consumption.

## 1.3 Research Goal

The objective of this research is to advance knowledge and demonstrate the practical applicability of low-energy Personal Comfort Systems to provide local thermal comfort and energy savings in office environments. This work seeks to remove barriers to industry adoption of low-energy Personal Comfort Systems by designing novel devices, optimizing performance through laboratory testing, and developing research methods to allow large-scale field tests of these systems. The work is organized into four main chapters: the first three describe the development and testing of each of three specific devices (cooling fan, radiant footwarmer, and conductive work surface), and the fourth details the personal comfort system overall, as well as the associated research methods.

# Chapter 2

## Cooling Fan

The ultimate centerpiece of the CBE PCS system is a small, very-low-energy fan, which provides local cooling to the face and breathing zone.

### 2.1 Fan Background, Problem, and Objective

With a background in personal thermal control, and some concepts for integrating this approach in workplaces, the next challenge was to develop working prototypes for the range of possible approaches to test and refine. This exploration required a combination of literature search, product design, performance testing and industrial engineering.

The effort began with the design of a low-energy fan to provide cooling through elevated airspeed. This design problem includes a number of specific challenges. The goal was to move as much air as possible with as little energy or noise, and that required careful attention to every component, motors, bearings, blades, cowlings and controls. The volume, velocity and shape of the airflow would directly affect comfort, and emerged important parameters for design. Similarly, the fan would serve as the core of the PCM system, and so needed to be a research instrument or “desktop weather station” integrating sensors, data storage and communication components. Finally, it had to be user friendly, aesthetically satisfying, durable and cost-effective to allow a large scale production.

### 2.2 Concept Development

The design for the new personal comfort system began with the design of the fan, which would become the centerpiece of the entire system. The first version—created in the fall of 2009 and later dubbed Fan 1.0—presaged many of the features that would later develop into the final form.

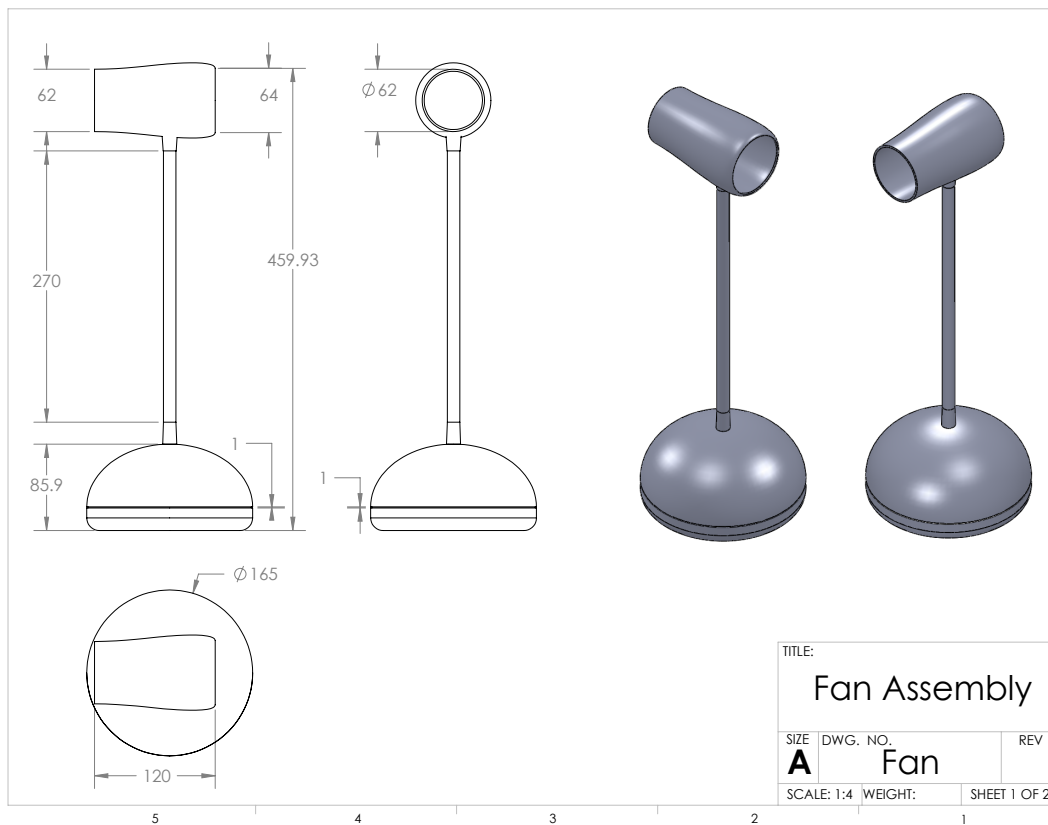

Figure 2.1: CAD drawing showing the assembly of little Fan version 1.0. Note the overall form of a fan cowling connected to a round base by a flexible goose-neck that would carry through to the production version.

The overall assembly, shown in figure 2.1 clearly reveals the three main elements: a cowling to surround the fan for airflow, acoustic and safety reasons; a flexible gooseneck to allow users to reposition and aim the airstream; and a weighted base holding the electronics. The motor and fan blades were a 62 mm computer cooling fan, which offered relatively low energy consumption and was fairly quiet. The corners were ground off the square fan and it fit by friction into the simple truncated-cone geometry of the cowling. At 270mm the gooseneck was quite long, but acceptably so given the low weight of the fan and cowling assembly. The base was essentially a half-sphere, in this case the height of the dome was critical as it housed three separate pieces of electronic equipment, one each to receive the remote signal, process the inputs and sensor information, and to provide a control signal to the fan itself. This modular design was a literal carryover from the bench-top testing, with the components simply inserted into the housing. External to the base and not illustrated in the drawings was a large rectifier to convert the AC current



from a wall outlet to 12 volt direct current for the fan.

There were no physical or digital controls on the fan itself, users turned it on and off, and cycled through the three speeds using a remote fob much like a automobile remote entry. The intent was to offer great freedom to position the fan in the best location, even if that were out of reach or behind the user. Concept renderings produced at the same time suggested placement at the edge of desks (figure 2.2a), integrated with the top of modular furniture (figure 2.2b), and even on the ceiling (figure 2.2c).



(a) *Little Fan version 1.0 located on the desk in a fairly conventional workspace. Note the placement to one side of the user.*



(b) *Additional placement options imagined the little fan integrated with systems furniture to take advantage of remote control.*



(c) *Concept integrating small fans with the ceiling to offer point-source air movement throughout a re-configureable, open-plan workspace.*

Figure 2.2: Artist's renderings of Little Fan version 1.0 in various interior settings

In practice, however, it quickly became clear that this small fan was not strong enough to provide sensible airflow at long distances (anything greater than about 0.5 meters) limiting the need for the remote control as the fan had to be within arm's reach to be useful. The fan was showcased at the October 2009 Center for the Built Environment Partner



meeting, but even the most cursory of user interaction with this first prototype showed that the personal control of the position and aim meant users wanted to touch the fan to adjust it and they wanted to control the speed there as well. These insights prompted a chain of increasingly tactile experiments, culminating in the turned acacia-wood fan 3.0 nicknamed “Woodie” which is illustrated in figures 2.11 and 2.12. Developing this highly tactile response is only one example of the cycle of testing, feedback, and iterative design work outlined in figure 2.10. Another, and perhaps more important insight and evolution was that the early prototype prompted the search for a stronger fan with increased airflow, and to look for a wider array of approaches to deliver local comfort beyond simply moving air.

In many ways the earliest draft set the stage for future explorations, establishing a basic form of local fan, and identifying the challenging requirements for the three major systems. First, we needed a more powerful fan and motor in order to provide adequate airflow to ensure comfort, but it needed to consume relatively little energy. Furthermore, unless that fan was also quiet, people would be unwilling to use it in their workspace limiting adoption. Second, the design of the system—in particular the cowling surrounding the fan—was a combination of practical factors (i.e. hold the parts securely, induce additional airflow, direct the air as desired) as well as human factors design demanded of a personal device like this one. Those requirements included shielding the fan from view and touch while enhancing the airflow and acoustics, promoting intuitive engagement and aesthetic concerns. Third, this little fan with a big base illustrated the importance of designing the electronic components for simplicity, energy savings and reduced physical size. These requirements led to the explorations of the next phase.

## 2.3 Fan Design

Among the first tasks was to improve on fan 1.0 to increase volume of airflow, the air velocity at the user and the distance at which it would be effective. Concurrently, the fan needed to be made quieter to be acceptable in a working environment, and needed to ensure very low energy consumption. This breadth of criteria required fairly extensive effort on a range of topics.

### 2.3.1 Fan Selection

While fan 1.0 used an off-the-shelf 50mm computer case (muffin) fan, the intention was to design and build the fan from scratch by selecting separate motors and propellers. Through some initial attempts to use remote control hobby aircraft components, such as those in figure 2.3, we found it challenging to get consistent, reliable assembly, and the components tended to be noisy in operation. We settled on pre-made ball-bearing (or in



(a) Turbine-type fans and motors considered for early prototypes (b) Prop-type propellers and motors considered for early prototypes

Figure 2.3: Originally, the intent was to design the fan around motors and blades purchased separately and integrated by us, such as these hobby fans and model aircraft propellers.

some cases magnetic bearing) computer cooling fans as the most reliable method to provide airflow. The computer fans offered vastly superior performance across a range of criteria, including airflow, noise, energy use and cost. While there were many options, the fans we choose to evaluate are listed in table 2.1. Although very reasonably priced, these computer cooling fans were generally very well made for long service and continuous operation. Some of the fans were the product of extensive engineering to optimize airflow (to increase either volume or static pressure) to reduce energy use, and above all to eliminate noise. This was fortuitous, because quiet operation was such an important design criterion for the PCS fan to be accepted in the office environment.

The best fans included brushless motors, which were generally quieter and more powerful for the same energy consumption. Another innovative technology, the fluid dynamic bearing (FDB) offered longer life, quieter operation and reduced noise. A few fans even featured self-stabilizing magnetic bearings which essentially eliminate friction from physical contact. The Coolink products selected for ultimate development both feature this technology. Some products, such as those from Noctua had clearly lavished fluid dynamics engineering on the fans, resulting in designs with beveled or stepped blade tips, notched trailing edges and built in electrically commutated motors.

One critical decision was the control regime. The most basic fans used two-wire motors, with one positive and the other a ground. On a two-wire fan, speed is varied by varying the potential (voltage) between the two wires. Three-wire fans incorporate a speed-sensor, which sends a speed signal (usually called “Tachometer Out”) on the third wire. Finally, there are four-wire fans, which use Pulse Width Modulation (PWM) to control fan speed by varying the relative width (duration) of on and off pulses to simulate different

MFR	Description	MFR Item Number	Price	? (mm)	RPM	CFM	dB(A)
Scythe	Mini Kaze 50mm silent fan	SY501012M	\$6.95	50	4500	9.42	26.09
	80mm 7 blade quiet fan	NF-R8-Low	\$15.95	80	800	15.30	7.00
NoiseBlocker	80mm 1200 RPM fan	M8S1	\$24.99	80	1200	17.66	6.00
Scythe	Kama Flow 2 80mm 1400RPM	SP0825FDB12L	\$11.5	80	1400	18.97	14.00
Coolink	80mm 1100RPM fan	SWiF2-800	\$10.95	80	1100	19.18	9.50
Nexus	80 mm Case fan	SP802512L-03	\$8.49	80	1500	20.20	17.60
	80mm 7 blade quiet fan	NF-R8-Mid	\$15.95	80	1300	22.95	10.00
Noctua	80mm 7 blade quiet fan	NF-R8	\$15.95	80	1800	31.19	17.00
Nexus	80mm PWM case fan	SP02512H-03PWM	\$8.49	80	2800	38.00	16.20
Scythe	120mm 1200 RPM fan	SY1212SL12L	\$11.95	120	1200	24.03	21.71
Scythe	Gentle Typhoon 120mm 800rpm	D1225C12B2AP-12	\$14.95	120	800	28.25	9.00
Scythe	Kama Flow 2 120mm 900RPM	SP1225FDB12L	\$14.8	120	900	30.54	11.00
Scythe	S-flex 120mm 800 rpm fan	SFF21D	\$13.29	120	800	33.50	8.70
Noctua	120mm Flexible Quiet fan	NF-S12B_FLX	\$19.95	120	1200	59.21	18.10
Thermalright	Stealth Silent 120mm 1600RPM	TR-FDB-1600	\$12.95	120	1600	63.70	28.00
Nexus	120mm PWM case fan	D12SL-12 PWM	\$12.49	120	2000	76.00	26.90
Noctua	140mm round quiet case fan	NF-P14 FLX	\$21.95	140	1200	64.92	19.60

Table 2.1: Table showing the specifications for the various computer cooling fans evaluated for use in the PCS fan. All data is provided by the respective manufacturers.

voltages. On a 4-wire fan, the positive wire is always at a constant 12 volts relative to the neutral ground. The third wire carries a speed signal from the fan to the control, while the fourth wire carries a PWM control signal back to the fan. Obviously the setup has major implications for the design of the power supply and fan controls. Interestingly, the method of fan speed control also affects energy consumption and above all, noise. PWM offered the best energy performance of the options considered, as well as a wide range of controllability from a relatively simple circuit. While we ultimately chose to use PWM control, this did present some challenges. Most critically, the frequency of pulses in a PWM control regime may introduce audible noise, unless the frequency is set to be above the range of human hearing (generally considered to be greater than 20 kHz).

We knew that good acoustics were a prerequisite for success of the Personal Comfort Systems. If users objected to the noise they would not use the device, no matter how effective the cooling or efficient the energy consumption. With that in mind, we tested a lot of fans for subjective acoustics especially looking not only at volume of noise, but more critically the character of the sound such as pitch and harmonics. While nearly all fan manufacturers publish acoustic data, they usually provide only a single A-weighted Decibel (dBA) value, which cannot account for the frequency distribution's effect on noise perception, such as harmonics or imbalances.

### 2.3.2 Cowling Design

Computer simulation of fan and cowling design is difficult because fans are by definition a turbulent system. We opted to undertake extensive physical and empirical testing of various fans, as well as the inlet and outlet nozzle designs for the surrounding cowling. The original cowling on fan 1.0 was a simple tapered cylinder, designed more for ease of fabrication than any other consideration. As shown in figure 2.1, the inside tapered smoothly so that the computer fan (with the edges rounded off) could be simply pressed into the fan for a friction fit. The position of the fan in the cowling was set by how much or little of the fan was ground away. We recognized that the cowling was a key component of the fan design from both aesthetic and performative standpoints, and set out to design a good one.

### 2.3.3 Wind Tunnel Testing

Critical to the performance of the cowling, and to maximizing the benefit of the fan, was developing an efficient airflow pattern, with a tight jet, long throw, little noise. The cowling would also screen the moving parts from users to avoid visual distraction, and provide a clean cutoff for the inevitable IR sensor. The tight jet would enable operation at longer distances and, with a clean edge, entrain additional air to increase the effective volume of air with minimal additional work.

We ultimately focused on centerline air velocity as the critical metric because the premise of the personal comfort system is a small, user-controlled and highly-localized air flow. Given a sufficiently focused airstream, users will direct the air at whichever part of their body required cooling. Thus the fan and cowling design needed to provide an air jet with the maximum air speed thrown the longest distance while consuming the least energy. Given those constraints, fans or cowlings that provided broader distribution of air at the expense of centerline velocity would be less desirable, while a fan that provided a high central velocity and a broad distribution would not be penalized. Figure 2.8 shows the air velocity measured at the centerline of the fan at various ranges for the various combinations of nozzles and inlets attached to the second version of the fan. Test measurements for the original little fan version 1.0 are shown for reference.

To test the design of cowling elements, we picked a standard fan. In this case a Coolink SWiF2-120P, which measures 120mm in diameter. We built a testing fixture that would hold the fan securely, and a minimal control circuit that would allow operation at multiple speeds. We then designed and rapid prototyped a series of inlet (upstream) and outlet or nozzle (downstream) components. Each part was also 120 mm in diameter and featured a square base with mounting holes so it could be bolted to the fan, leading to two nicknames—“Frankenfan” and “Fankenstein”—both reflecting the fact that fan version 2 is bolted together from modular component parts. Figure 2.4 illustrates two examples of these combinations mounted to the testing fixture.

While the shapes were not the output of a deterministic mathematical model, they were also not random guesses, but informed choices based on principles of airflow.

A similar effort to quantify the performance of relatively small air nozzles at relatively low velocities was made by Malmstro et al., who in a 1997 paper describe their measurements and analysis of the centerline velocity of small, low-velocity air jets. They divide the air jet into four zones, the first three of which are illustrated in figure 2.5. In the core zone—within about five outlet diameters  $\frac{x}{D} = 5$  of the nozzle—the centerline velocity is affected only by outlet velocity. In the second or transitional zone, the centerline velocity begins decreasing and the air stream develops such that the profile of velocities across the width of the jet will be similar even at different distances. When that occurs, the jet is considered fully developed and enters the third zone—generally around fifteen fan diameters  $\frac{x}{D} = 15$  downstream from the outlet. Malmstro et al. state that in this zone, the decrease in centerline velocity is related to downstream using the simple decay equation shown in 2.1 which relates velocity to distance using the K-value, a dimensionless coefficient.

$$\frac{U_x}{U_o} = K \frac{D}{x - x_p} \quad (2.1)$$

The left hand side of this equation simply calculates the decay in air velocity; dividing the velocity at a given centerline position,  $U_x$ , by the the outlet velocity  $U_o$ . On the right side, that decay in velocity is related by the coefficient  $K$  to the diameter of the nozzle outlet,  $D$  divided by the distance between the given position  $x_p$  and the virtual origin of

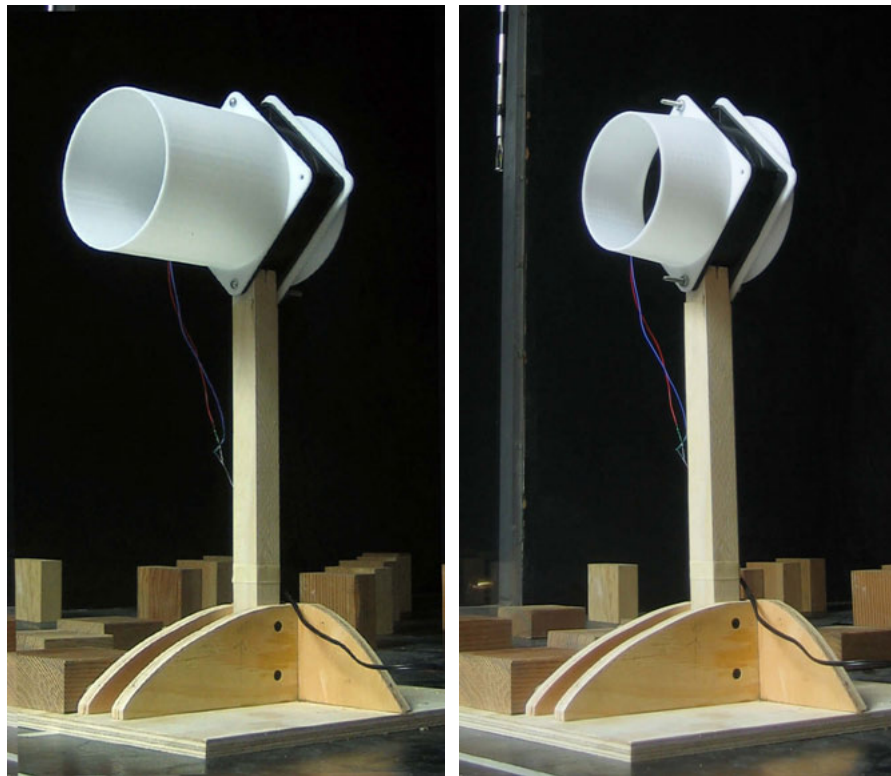

(a) Testing fixture with long straight nozzle and rounded inlet (b) Testing fixture with short tapered nozzle and rounded inlet

Figure 2.4: Examples of cowling options tested to evaluate the effect on the airstream



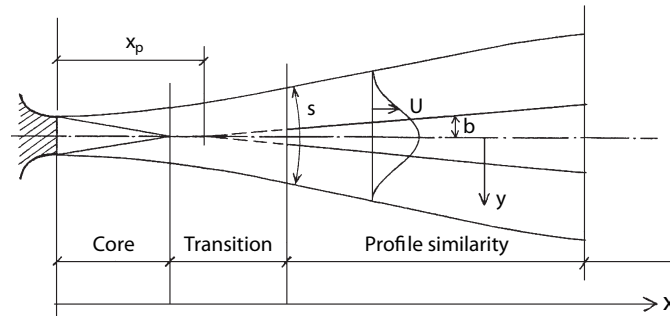

Figure 2.5: Symbols and notation showing the first three of four zones in the air jet model from (Malmstro et al., 1997).

the jet  $x$ . Using this model, the authors measure a number of jet sizes and air velocities to calculate the decay coefficients for different combinations of outlet size and initial velocity.

Although not an identical situation because their nozzles were supplied with pressurized air and did not contain a fan, Malmstro et al. found that for low-velocity jets (like the CBE fan) centerline velocity decay was more closely correlated with the decay coefficient and outlet velocity, than with Reynolds number or outlet diameter, noting,

“for the low-velocity air jets from round nozzles...the values of the centreline velocity decay coefficient  $K$  decrease at low outlet velocities below  $6m.s^{-1}$ . No simple dependence on the outlet Reynolds number is evident and the outlet velocity is a better basis for correlation. The reason for this behaviour is not clear.” (ibid.)

This finding guided the development of the fan in two ways. First, it indicated the primacy of centerline velocities to describe the behavior of low-velocity air jets, which simplified testing and analysis, as seen in figure 2.7. Second, it indicated the utility of outlet velocity for understanding overall centerline velocity decay, rather than focusing on outlet diameter. Taken together, these findings meant we could use centerline outlet velocity as a design target, and focus on increasing centerline outlet velocity with each design iteration.

Our iterative testing took advantage of rapid-prototyping equipment to quickly produce new parts as we had new insights or wanted to test additional ideas. We experimented with various combinations of the fan combined with either inlets, outlets, or both to understand the effect on airflow. Based on initial findings, we performed more extensive measurements on a smaller subset of combinations, which are listed in table 2.2.

The testing setup consisted of the fixed wood test stand (clearly visible in 2.4) to support the fan as well as any attached inlet and outlet nozzles. The simple control circuit was set to supply consistent 12 VDC power, operating the fan at its maximum velocity for all tests. The fan and base were placed in the measurement area of the UC Berkeley

Version	Outlet	Inlet	K-value
2.1	none	none	1.7
2.2	Straight Nozzle 1D	none	0.5
2.3	Straight Nozzle 1D	Round Inlet 1/4D	1.3
2.4	Constricting Nozzle 1D	Round Inlet 1/4D	4.3
2.5	Diverging Nozzle 1D	Round Inlet 1/4D	3.3
2.6	Constricting Nozzle 0.5 D	None	8.7
2.7	Constricting Nozzle 0.5 D	Round Inlet 1/4D	3.3

Table 2.2: *Combinations of inlet and outlet components assembled into versions of fan 2.x.*

atmospheric boundary layer wind tunnel. The test area of the tunnel has a cross section of approximately 1.5 meters high by 2.1 wide. The tunnel fans did not operate during this test—it simply provided a protected area free of obstructions and with minimal air movement in which to perform the measurements—so the inlet, outlet and upwind roughness are not relevant to these results. The wind tunnel is also equipped with an omni-directional hot wire anemometer mounted on a rolling gantry to provide motion in all three dimensions. In this case the vertical motion was locked, and all measurements were taken in the horizontal plane level with the central axis of the fan, so only two degrees of freedom were needed. Figure 2.6 shows this gantry, as well as a research assistant setting up the spacing for a grid of horizontal measurements that will be used to describe the shape of the air flow. Finally, the tunnel is equipped with an ultrasonic fogger, that produces a cloud of nearly neutral-buoyancy water vapor for visualizing air flow.

In these tests we were interested in the velocity of the air, but also the spatial distribution of air movement. We measured air velocity, in part because it is the air speed that produces the cooling effect, and in part to characterize the distribution of airflow produced by the fan. Velocity measurements were taken across a grid of measurement points to produce a field of data, a color-coded example of which is shown in figure 2.7. At each point, we measured the average air velocity over a sixty-second sampling period. Assuming a symmetrical distribution reduces the data collection requirements by half, and produces a graph in which the left margin represents the fan centerline and the bottom margin is the plane of the fan-blade rotation. In the example of 2.7, measuring using the bare fan with no additional inlet or outlet, we see the greatest velocities near the perimeter of the fan where the blade tips are the fastest-moving component. The airspeed remains above two meters per second for about the first 500mm of distance, and then fairly quickly drops off such that, by the one meter mark the airspeed has dropped below 1 m/s.

Measuring low-velocity jets is challenging because of turbulence and instability, as Malmstro et al. (1997) note, “weak jets tend to move around slightly in the room, sensitive to any disturbance. Even when no disturbance is apparent, the jets are not quite steady.” So while the data in figure 2.8 are quite noisy and highly variable, the trends are fairly





Figure 2.6: Research assistant Spencer setting up the anemometer gantry to measure the air-speed of various nozzles and inlets mounted on a standard fan to inform fan cowling design.

clear. In general, the second version of the fan offered greater velocities and longer throws than the little fan simply because it was built around a larger computer fan. However, as the data in figure 2.8 indicates, the various inlet and nozzle combinations do affect the air velocity and range.

Overall, the best-performing fan 2.X combinations achieved nearly double the centerline airflow velocity in the critical distance range of 500–1500 mm, while consuming approximately the same power as the previous version 1.0 design. Fan 2.X variations also offered longer total throws, with effective (defined as greater than 1 m/s) air velocities at a range of nearly two meters. Key factors included the rounded inlet and a slightly-tapered outlet nozzle slightly greater than one fan diameter long. Observations using water vapor to visualize the airstream showed that these design elements afforded relatively smooth entry, which emerged as the critical design feature. The other designs are fairly similar, offering some design flexibility for the future. These principles and geometries were adapted into all subsequent prototypes.

The best-performing inlet and outlet combination was mounted to a swing-arm base (similar to those used on some desk-lamps) to produce fan version 2.4, shown in figure 2.9. The resulting fan could be easily positioned over a large range of motion, and the large,

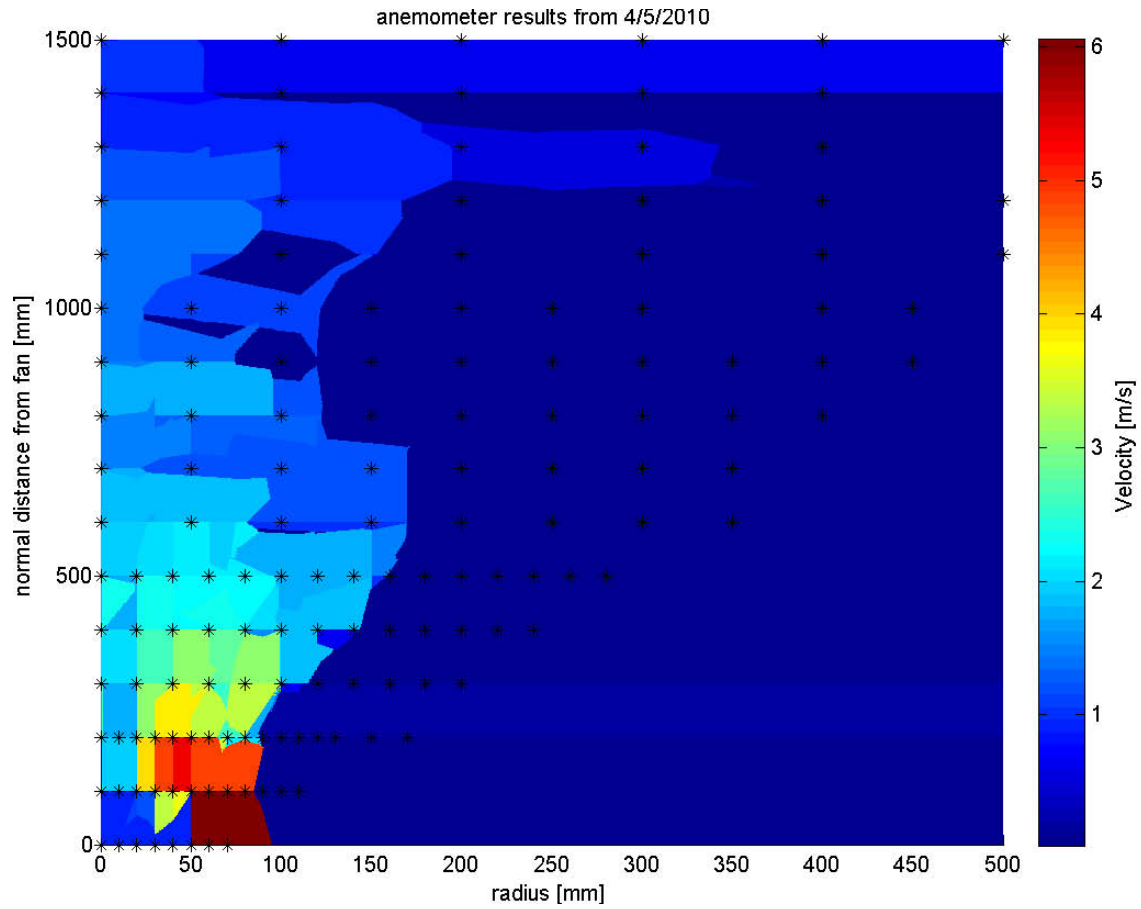

Figure 2.7: Graph of the spatial distribution of air velocities produced by the bare fan 2.x with no inlet or outlet. Note the significant variation (turbulence) of the fan compared to the ideal air jet shown in figure 2.5.

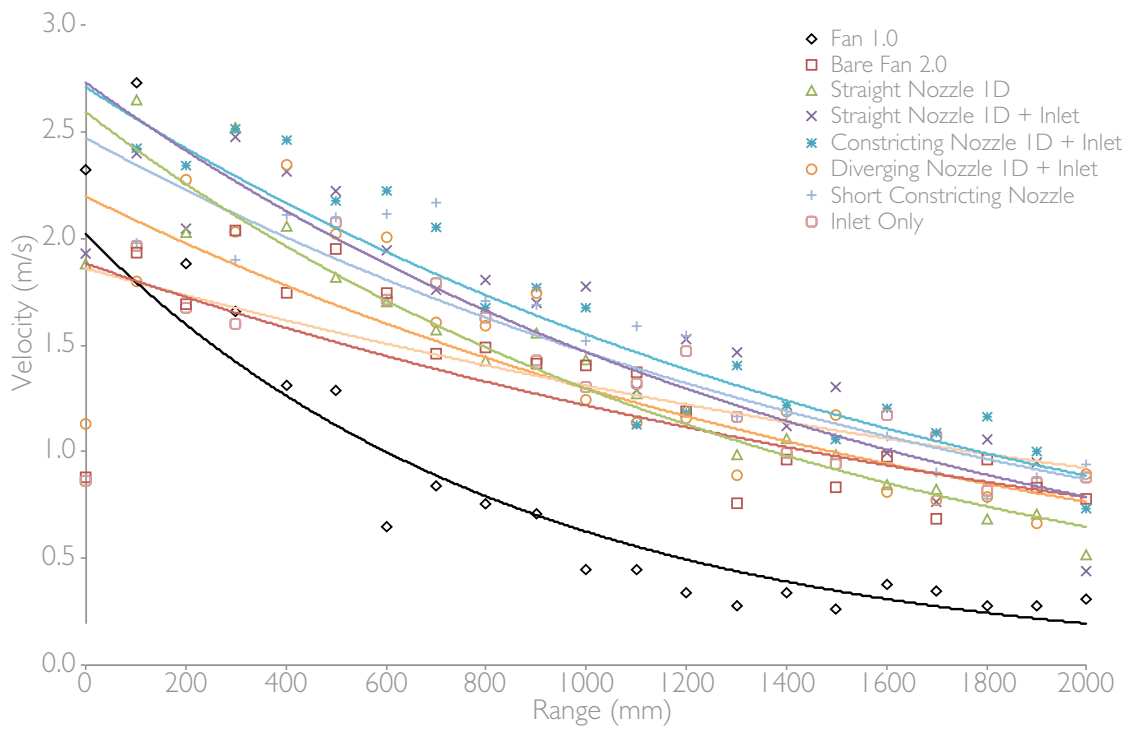

Figure 2.8: This graph shows centerline air velocities for various inlet and nozzle combinations on fan version 2.X, as well as the baseline measurement for fan 1.0 Note the substantial difference in velocity at ranges greater than 500 mm.



Figure 2.9: *Fan version 2.4 "Fankenstein" is the result of combining the best-performing inlet and outlet combinations and mounting them on a swing-arm base.*

120mm diameter offered both a long throw and a high air volume. This particular design afforded a great deal of flexibility, for example to locate the fan base behind the user with the fan blowing to the side or back of the body, and to more easily provide cooling in a large or unconventional workstation.

Although not needed as a design parameter, we calculated the K-value for each inlet and nozzle combination based on these measurements. As previously stated, the air jets tested by Malmstro et al. were produced using nozzles supplied with pressurized air, while the presence of the fan blades and motor in the central hub of Fan 2.x means that the centerline air velocity at the nozzle outlet may not reflect the concept of discharge velocity contained in the term  $U_o$ . To address these limitations, we assumed that the core zone of the air jet will occur somewhere within the first five fan diameters  $\frac{x}{D} = 5$  downstream from the physical nozzle outlet, and selected the maximum measured centerline velocity from this zone to use as the outlet velocity  $U_o$ . Even with this convention some designs—particularly the diverging nozzles—did not show their maximum velocity in this

supposed core zone. Furthermore, this equation describes the velocity decay only in the fully-developed jet stream, so like Malmstro et al., we omit from analysis any data where  $\frac{x}{D} < 15$ , as the jets are not yet fully developed. For fan 2.X with a diameter of 120 mm, this translates to 1.8 meters, and most of our 2.0 m test range and means the K-value calculation is based on only three measurements, limiting its accuracy and usefulness. For example, calculating version 2.6, the fan with the short constricting nozzle and no inlet, results in a spurious K-value of 8.7. With no inlet and the short outlet, the airflow from the axial, bladed fan never develops into a proper jet as described by the theoretical model Malmstro et al. tested using pressure jets. This lack of developed flow can be seen in the relatively low and consistent centerline velocities for the first 0.7 meters of fan version 2.6, and the highly variable velocities for the rest of the range. The calculated values for  $K$  are provided in 2.2 for information, but were not used to refine the design.

### 2.3.4 Family Tree

As the development effort continued, the sheer number of prototypes, particularly for the fans, required an organizational scheme, leading to the fan family tree shown in figure 2.10

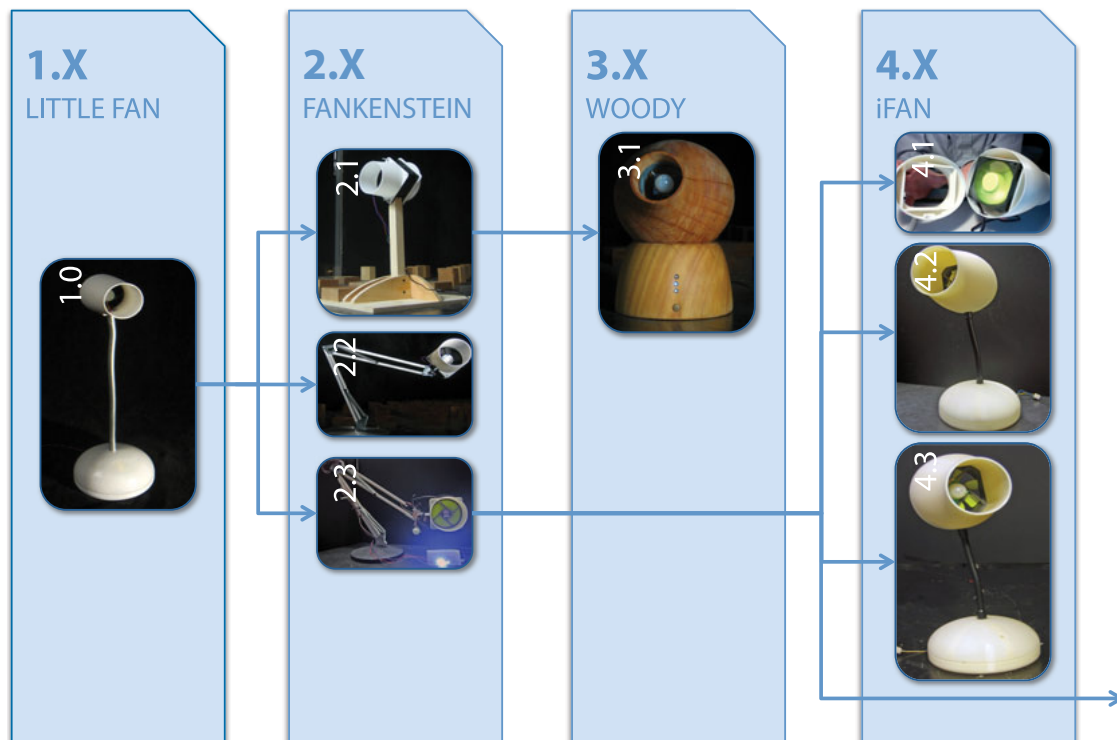

Figure 2.10: A family tree showing the evolution of prototype fans developed over the course of the project.

## 2.4 Human Interface

The challenges of human interface design presented by the first version of the fan, as well as concerns that the march toward design for mass production would yield an aesthetically unsatisfying plastic object, provoked another line of exploration that ultimately resulted in fan version 3.0. Rather than begin with assumptions about features or performance, the premise of this version was to start the fan design with the simplest form, controls, and operation possible and ruthlessly resist any added complexity. In a related effort, the design proposed a vision of the personal comfort system as a precious object: a source of delight and pride that begged to be touched and used, rather than a utilitarian commodity occupying space on a desk. The result was the hand-turned wood fan with simple controls shown in figure 2.12.

### 2.4.1 Woodie

Figure 2.11 shows early sketches for version 3.0 of the fan. The simple form of a sphere sitting in a base afforded easy adjustment to direct the airflow through a full range of three dimensions without the complexity of lamp-like spring arms (as in version 2) or the need for two-handed adjustment using a metal flexible arm (as in version 1). The shape suggested an intuitive interaction, and required only one hand or perhaps a single finger to move. A slight distortion of the sphere created the directional nozzle and smooth inlet the wind tunnel testing demonstrated were necessary for quiet and efficient fan operation. The resulting shape would entrain additional air smoothly into the directed jet while shrouding the fan fully inside itself. This shape also afforded a significant range of motion, as shown in figure 2.12.

In addition to directing the airstream, user interaction includes controlling the operation and speed of the fan. Although version 1 of the fan had a remote control with only two buttons (one to turn the fan on and off, the second to cycle through the various fan speeds) many users found this confusing, and it begged the challenge of a simpler, single-button control. Previous research suggested users only used discrete speed settings, rather than continuous control (Bauman et al., 1998). With this in mind, fan version 3.0 had a single button that cycled the fan from off, through three speed settings and off again. Three white LEDs indicated the speed setting, and would pulse gently to indicate when the fan fell asleep. There were no other use controls and all the electronics were embedded into the base with a single power connection to keep the form simple and pure. This shape also offered radial symmetry, affording some possibility for repetitive fabrication methods like turned metal or wood.

Leaving aside the pragmatic concerns of mass-production, choosing to fabricate the fan prototype by hand from a natural material like wood recognized the intimacy of the fan and the user, in part because of physical proximity but also the human touch to control the fan, and the constant caress of air as the fan provided a cooling breeze. Such

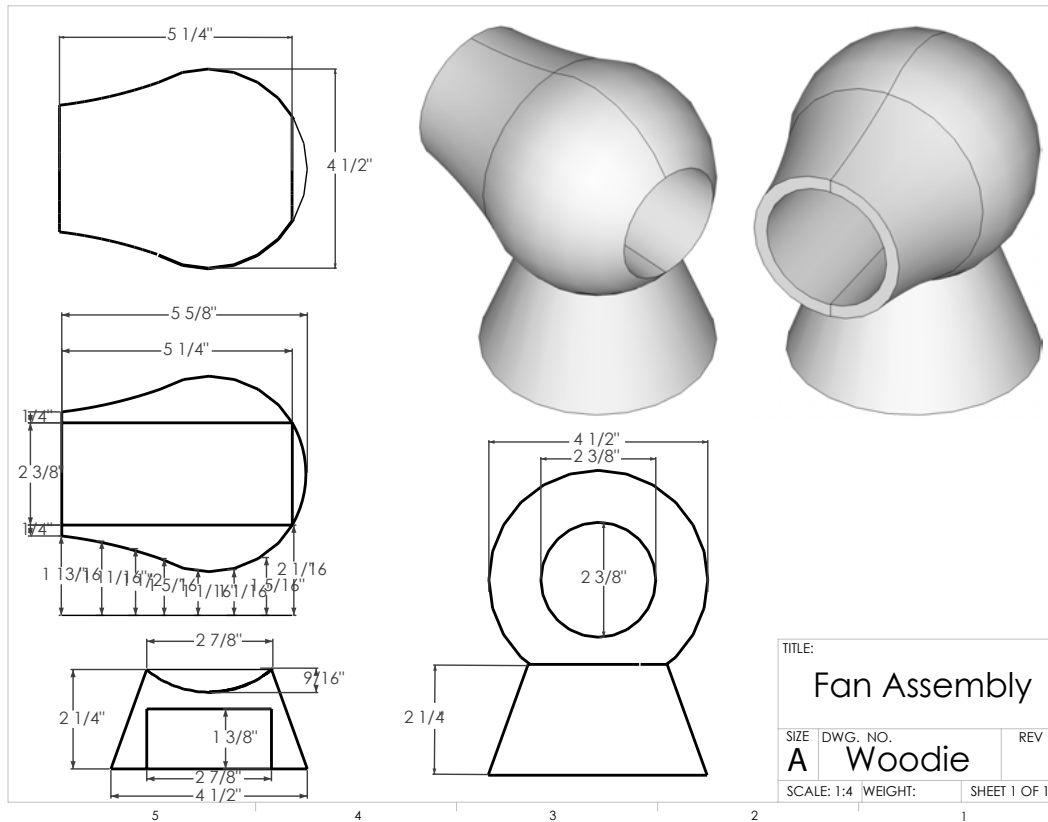

Figure 2.11: These early sketches for a “sphere on a stand” fan guided the development of the turned-wood version 3.0 of the fan, nicknamed “Woodie”.

hand-made objects also assert their value through authenticity in the face of mechanical or digital reproduction (Benjamin, 1968). Figure 2.13 shows some of the steps involved in the physical production of this prototype.

User testing of the completed prototype bore out many of the expectations, particularly that people could not resist touching and moving the wooden version of the fan: the most common comment was “can I have one?” Unexpectedly, the single button control and the discrete speed settings were the main source of complaints, with users suggesting they would prefer more nuanced control, and a more intuitive, obvious interaction.

## 2.4.2 Controls

Based on previous research, and a basic quest for simplicity, we had adopted a control system with three fan-speed settings. This decision was inspired by Bauman et al. (1998), who found in their field study that occupants generally did not take advantage of the





Figure 2.12: This series of photographs form a filmstrip showing the repositionable turned-wood version 3.0 of the fan, nicknamed "Woodie".

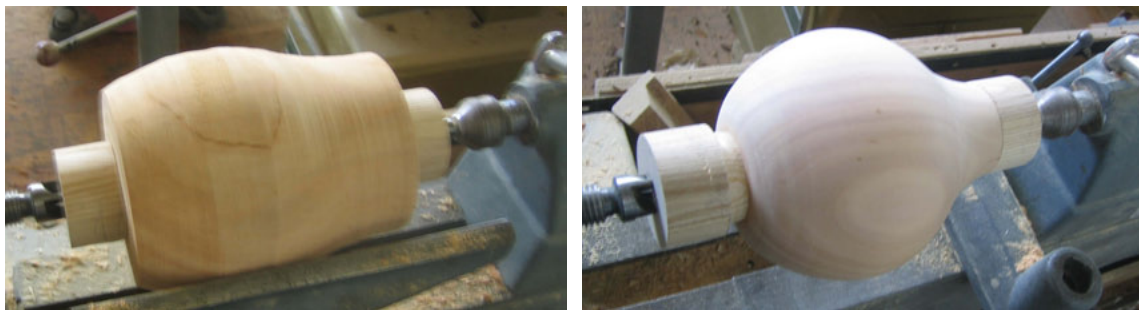

(a) Rough turning the fan shape on a lathe

(b) Smoothed fan shape on the lathe

Figure 2.13: Fabricating fan 3.0 involved manually turning a center-bored wood blank on the lathe and then inserting the fan propeller, motor and other electronics.

fine-grained continuous control provided by Johnson Controls Personal Environmental Modules, noting that “No occupant fine-tuned the unit as if it were a continuous analog control.” Instead, the researchers found the comfort outcomes were achieved with minimal adjustment of the controls, and compared the use to a switch. User control patterns indicated that users only adjusted the system when conditions changed, and suggested that a three-position switch is sufficient, and continuous control is not required.

In contrast to this past work, anecdotal feedback as the design developed indicated a strong preference for continuous control, and for a rotary dial rather than push-button interface. Allowing users to run the system as slow as they wished could save energy. Up until this point in the design, we imagined designing and fabricating a custom circuit to integrate the controls, sensing and voltage regulation tasks for the personal comfort system onto a single board. However, as design progressed, we recognized the costs, both financial and in lost flexibility, and made the critical decision to build the system around a flexible micro-controller platform, in this case an Arduino. Among other things,



this change made it possible to incorporate a continuous control system.

## 2.5 Performance Testing

### 2.5.1 Intro to CFE

Progress on Fan version 4.3 continued in parallel with the development of a performance specification for low-powered cooling fans for PCS. This effort was initially undertaken at the request of the General Services Administration, and the initial draft specification is in appendix A. In developing this specification, we realized that our previous measurements quantified important attributes of the fans like air velocity, volume, energy consumption and noise; but those attributes, even taken together, did not necessarily translate directly to the performance of the fan as a cooling device in a personal comfort system. This was particularly important because we were not considering items like the fans in table 2.1 in isolation, but rather after they were integrated into the PCS system with nozzles and controls. A performance specification needed a measurable basis in order to compare these options, and determine if a specific fan system achieves the desired cooling performance. This is a difficult problem as the purpose of the fan is to affect human thermal comfort, which is a difficult phenomenon to quantify. Furthermore, the specification we were developing, and the product we were prototyping needed to encompass the widest range of design freedom possible, which would make testing difficult. We sought a quantified testing protocol to compare the effectiveness of our various fan designs to each other, as well as to the wide variety of other fans on the market.

Commercial products generally describe fans' speed, measured in revolutions per minute, and air delivery, measured as a volume of air per unit time. Previous government specifications for similar products (e.g. Army-GL, 1992; GSA-FSS, 1998) rely on these same parameters to specify performance. Indeed, all the fan specifications reviewed simply detailed a method and procedures for testing, rather than attempting to specify comfort, which is of course the ultimate use to which the fan will be put. So while these metrics lent themselves to easy quantification, they told nothing about the affect of the fan on people. In spite of the detailed procedures, the existing specifications were also descriptive, determining what the product was, or prescriptive, describing how it worked. We sought to specify performance, which would require a different kind of metric.

Fortunately, others had recognized these same difficulties. In a 2009 paper, Schiavon and Melikov note the shortage of useful performance measures for fans, saying,

“Appearance, power consumption, and price are the main parameters considered when purchasing cooling fans, while cooling capacity and efficiency of energy use are unknown. Other factors, such as ergonomics, control options, etc. are also important.” (Schiavon and Melikov, 2009b)

The authors go on to propose a new measure they call the Cooling-Fan Efficiency (CFE) index to help address some of these limitations, and then provide the results of testing a number of common types of fan. The authors define the CFE as “the ratio between the cooling effect (measured with a thermal manikin) generated by the device and its power consumption.” The cooling effect is described by a change in equivalent temperature ( $\Delta T_{eq}$ ) which is calculated using equations 2.3 and 2.4, and defined in detail alongside those equations on page 37. The instantaneous power consumption is measured while the fan is operating. This definition is also expressed in equation 2.2.

$$CFE = \frac{\text{Cooling effect}}{\text{Fan power}} = (-1) \frac{\Delta T_{eq}}{P_f} \quad (2.2)$$

This definition follows the conventional understanding of efficiency as a ratio between an output and the input required to achieve it. Because this approach incorporates a measure of the fan’s effect on a person as well as the energy consumption, it represented a useful measure to compare the design of our personal comfort system fan designs to each other or to alternative fans tested by us and those tested by other researchers. To evaluate the efficacy of this measure for our specification, and in order to compare the PCS fans with others on the market, we set out to measure the Cooling Fan Efficiency of two different prototype PCS fans.

## 2.5.2 Method

### Experimental Facilities

CBE Model	Fan	$\varnothing$ (mm)	Speed (RPM)	Air Flow ( $m^3/h$ )	Power (W)
iFan4.3	SWiF2-80p	80	750-2000	24-52.3	1.08
Fankenstein 2.4	SWiF2-120P	120	800-1700	60.4-127.6	3.96

Table 2.3: Model numbers and specifications for the fans evaluated using the Cooling Fan Efficiency metric. Data are provided by Coolink unless otherwise noted.

Two fan designs were tested using this procedure, the iFan 4.3 built around a Coolink SWiF2–80p, and the Fankenstein 2.4, built around a Coolink SWiF2–120P. Specifications and characteristics of the fans are reported in table 2.3. Both fans were operated by their Arduino micro-controller, running version 1.0 of the code, which provided for three fan speeds (low, medium, high). Greater fan speeds are expected to increase velocity of air flow. The infrared occupancy sensors that would normally turn off the fan after a period of inactivity were disabled for this test as no human would be present in the fan air-stream.

Measurements were conducted in the Controlled Environmental Chamber at UC Berkeley, which is configured as a conventional modern office space. The chamber measures 5.5

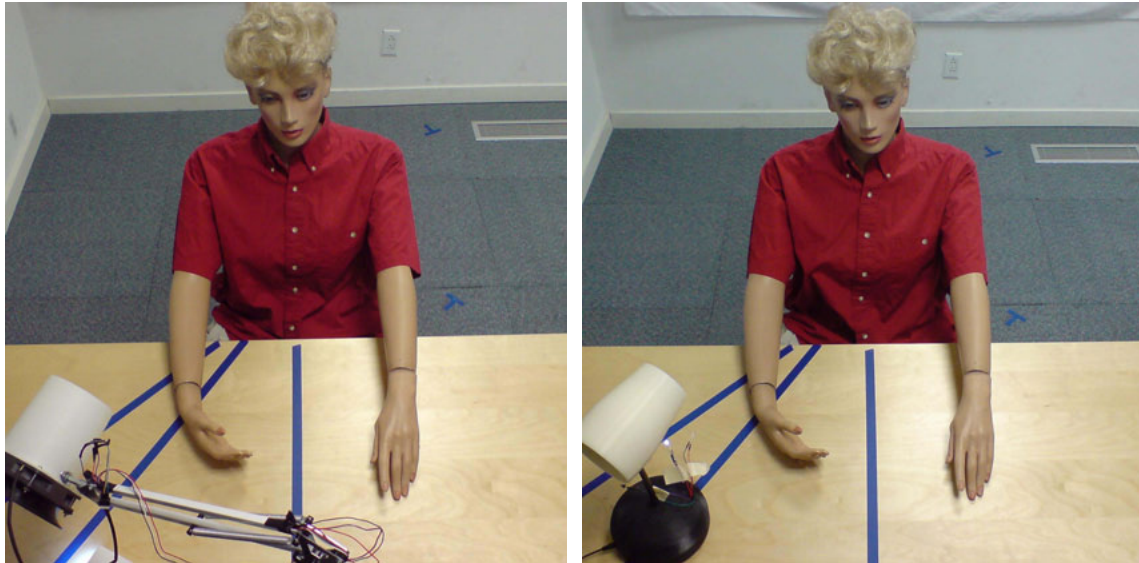

(a) Configuration of workstation for CFE measurement of fan v2.4 (b) Configuration of workstation for CFE measurement of fan v4.3

Figure 2.14: *Physical arrangement of the fans and manikin in the workstation for CFE measurement. Note the blue tape on the desk indicating angle.*

m by 5.5 m by 2.5 m (h), and has strip windows along the east and south sides. Although the windows are well-shaded by external fins and overhangs all tests were performed at night to avoid solar radiation. All windows were hung with light cotton cloths to avoid radiant exchange; these clothes are visible in the background of figure 2.14 showing the experimental setup. The room is provided with a raised floor (not used in this test) and a dropped acoustical ceiling. The room temperature is controlled by an HVAC system supplying 100% outside air, at a rate of 4.6 air changes per hour. Air is supplied to the room through a 2 x 2 ft ceiling diffuser, and the air is exhausted at the edge of the ceiling.

A thermal manikin was used to simulate an occupant, and was placed in the workstation. Figures 2.14a and 2.14b show the arrangement with fan v2.4 and 4.3 respectively. The fan was located slightly above the desk surface, at a distance of 66 cm from the breathing zone of the manikin, and at an angle of 30 degrees to the right, as measured from the centerline. This arrangement is indicated by strips of blue tape on the desk visible in the photographs. The manikin was seated in a conventional office chair, with both arms above the work surface, and both feet flat on the floor. The manikin was dressed in a clothing ensemble consisting of panties, bra, short-sleeved shirt, pants, and shoes, with an estimated Clo value of 0.42 without the chair, and 0.52 with the chair.

## Measuring Equipment

The critical element of physical measuring hardware is the thermal manikin, named Monika. Thermal manikins have been used in research for over half a century. Holmér (2004) traces this history, from the original manikins developed to evaluate the insulating value of clothing, on to modern manikins used to measure complex and transient thermal environments. All thermal manikins operate by measuring the power required to heat the skin surface and maintain it at a constant temperature. Using these measurements of temperature and energy as inputs to a thermal sensation model, it is possible to calculate expected human comfort in that environment (McGuffin et al., 2002). Manikins differ based on the location of the heat source, whether on the outside surface, the inside surface or in the internal core. Monika is heated on the outside surface by a closely-spaced network of fine nickel wires wrapped around her 4mm thick fiberglass and polyester body shell. These same wires are used for both heating and temperature measurement, and are only 0.2 mm in diameter. The wires heat the manikin surface using intermittent pulses of current to heat the wire by resistance. To maintain consistent surface temperatures over the entire body, the wire spacing never exceeds 2 mm. Tanabe et al. (1994), in tests using the same manikin, found the maximum temperature difference observed between a skin location immediately above the wire and one equidistant between two wires was 0.5°C for a nude model with a heat loss of 100 W/m<sup>2</sup>. Because she is heated at the outer surface, and because the wires are covered only by a thin (0.1 mm to 1.0 mm) protective shield, Monika has a time constant of approximately 5 minutes. This is quite low compared to other manikins, particularly those with inside surface or internal heat sources.

Modern thermal manikins divide the human body into a number of body parts, each individually heated and measured to offer additional spatial resolution of the power and temperature changes caused by the thermal environment. Monika's body is divided into sixteen segments, listed in table 2.4, each part is separately controlled by an internal computer and connected out for data collection and analysis. While this offers some granularity, it also presents some limitations for the highly non-uniform thermal environment we expect a personal comfort system to produce. In contrast, McGuffin et al. (2002) describes a new Advanced Thermal Manikin developed by the National Renewable Energy Lab (NREL) for testing automobiles and other thermally complex environments, which is designed with approximately 150 separate zones. The advanced Thermal Manikin also accounts for latent heat, and features perspiration and respiration. This addresses a serious limitation of thermal manikins like Monika, which only produce and measure sensible (dry) heat. Of course humans sweat and breathe, and this affects their thermal regulation. Although cooling by skin evaporation makes a significant contribution to human temperature regulation in some environments and activity levels, the contribution in sedentary conditions inside the comfort zone (e.g. Offices) is fairly modest. So while evaporation is particularly effective in the presence of elevated air speeds as are being tested here, the lack of latent transfer means these measurements will tend to underestimate the to-

	Name of Part	Area (m <sup>2</sup> )
1	Left Foot	0.0446
2	Right Foot	0.0437
3	Left Leg	0.0892
4	Right Leg	0.0879
5	Left Thigh	0.1630
6	Right Thigh	0.1670
7	Crotch	0.1740
8	Head	0.1100
9	Left Hand	0.0397
10	Right Hand	0.0394
11	Left Arm	0.0490
12	Right Arm	0.0500
13	Left Shoulder	0.0736
14	Right Shoulder	0.0778
15	Chest	0.1380
16	Back	0.1270
	Total	1.4739

Table 2.4: Names and surface area for each body part of the thermal manikin.

tal cooling effect of the fan and are, therefore, somewhat conservative even in the office environment.

The air temperature of the chamber was constantly monitored by the building automation system to control the HVAC temperature and airflow, and recorded as shown in figure 2.15. A FLIR B60 infrared camera was used to measure the skin temperature, and visually document the affect of the fan on the breathing zone. This imager has a resolution of 180x180 pixels, a temperature range of  $-20^{\circ}\text{C}$ – $120^{\circ}\text{C}$  and  $\pm 2\%$  accuracy. Voltage and current of individual fan components were measured using a General Tools multi-meter. Power for the complete fan system (including transformer losses and controls) was measured using a P3 Kill-A-Watt P4400 meter. This unit has a precision of 0.1 watts, and an accuracy of 0.2%.

### Experimental Conditions

Two versions of the CBE fan were evaluated. Each fan was tested at two-speeds (high and low). Each fan and speed combination was tested for two ten-minute periods, and measurements were also taken in the still environment without the fans operating for a total of eleven test runs. The order of experiments was randomized to minimize the influence of uncontrolled or unknown variables on the results. The sequence of experimental conditions is described in table 2.5.

#	Test Conditions			Start		End	
	Model	Speed	Setpoint ( $^{\circ}\text{C}$ )	Time	$T_{\text{ambient}}$ ( $^{\circ}\text{C}$ )	Time	$T_{\text{ambient}}$ ( $^{\circ}\text{C}$ )
1	4.3	Off	25	18:58:40	25.1	19:09:30	25.1
2	4.3	High	25	20:46:42	25.1	20:56:50	25.1
3	2.4	High	25	21:37:15	25.1	21:47:25	25.2
4	4.3	Low	25	22:35:45	25.1	22:46:10	25.1
5	2.4	Low	25	23:58:56	25.1	0:09:34	25.1
6	2.4	Off	25	1:12:23	25.1	1:23:17	25.1
7	4.3	Low	25	2:16:00	25.1	2:26:33	25.1
8	2.4	Low	25	3:24:15	25.1	3:35:01	25.1
9	4.3	High	25	4:38:45	25.1	4:49:15	25.1
10	4.3	Off	25	5:37:05	25.1	5:48:01	25.1
11	2.4	High	25	7:04:55	25.2	7:15:41	25.1

Table 2.5: *Experimental conditions for evaluating Cooling Fan Efficiency.*

The room temperature setpoint was  $25^{\circ}\text{C}$ . Room air temperature was recorded every 60 seconds at the air handling unit (AHU) as shown in temperature trace in figure 2.15. The HVAC system maintained a temperature within a  $\pm 0.25^{\circ}\text{C}$  band – with the maximum



value of 25.2° and the minimum value of 24.8°C—suggesting the environment was closely controlled. There was a gap of approximately two hours in the temperature record at the AHU, however the temperatures recorded before and after each test and shown in figure 2.5 indicate a steady ambient temperature of 25.1°C so it is unlikely any major temperature fluctuations occurred in this period. Furthermore, this gap overlaps only two tests (test 3 of fan v2.4 at high speed and test 4 of fan v4.3 at low speed), and these test conditions were both repeated in subsequent tests (numbers 11 and 7 respectively) to minimize confounding factors. No differences in room air temperature were observed between tests 3 and 11, nor between 4 and 7, so we believe this gap in the data is negligible. Ambient air temperature in the chamber was also measured and recorded before and after each test using a mercury thermometer with a precision of  $\pm 0.1^\circ\text{C}$ . Those start and end temperature measurements are listed in table above, demonstrating the consistent thermal conditions.

### Experimental Procedure

For each experiment, the fan and manikin were arranged as described in table 2.5, and shown in figure 2.14. The system was allowed to achieve steady state conditions. Steady state is defined as a variation in the average surface temperature of the manikin of not more than  $0.05^\circ\text{C}$  ( $0.09^\circ\text{F}$ ) for a period of ten minutes, or two times the expected time constant. Once steady state conditions were established, the room air temperature was recorded for the start of the collection period. Data from the thermal manikin was recorded every 60 seconds for ten minutes. At the end of the collection period, the air temperature was again read from the thermometer and recorded, and thermal and conventional photographs were taken to document that configuration and results. The data file for the manikin and digital images were renamed and archived before the next test.

In between experiments and when re-setting the experimental setup, the room was perturbed to prevent inertia by using a large pedestal fan to thoroughly mix the air in the chamber. This disturbance was intended to overwhelm any local air effects near the manikin. The continuous temperature record from the HVAC system was periodically archived. Fan power was manually recorded before and after the experiments to assess energy consumption of the complete PCM unit (rather than the computer fan alone.)

### Statistical Analysis

For each test, the measurements of temperature and power for each segment of the manikin were averaged over the ten minute test period to eliminate noise. The resulting values describe the conditions at the manikin's outer skin surface, where heating and measurement take place but must be adjusted to compensate for the insulating value of the air layer and the clothing at each body segment. This insulating value is expressed using a segmental heat transfer coefficient  $h_{cal,i}$  which is measured in a standard environment as part of calibrating the manikin. To validate the standard measurements to these particular ex-

25.3 —

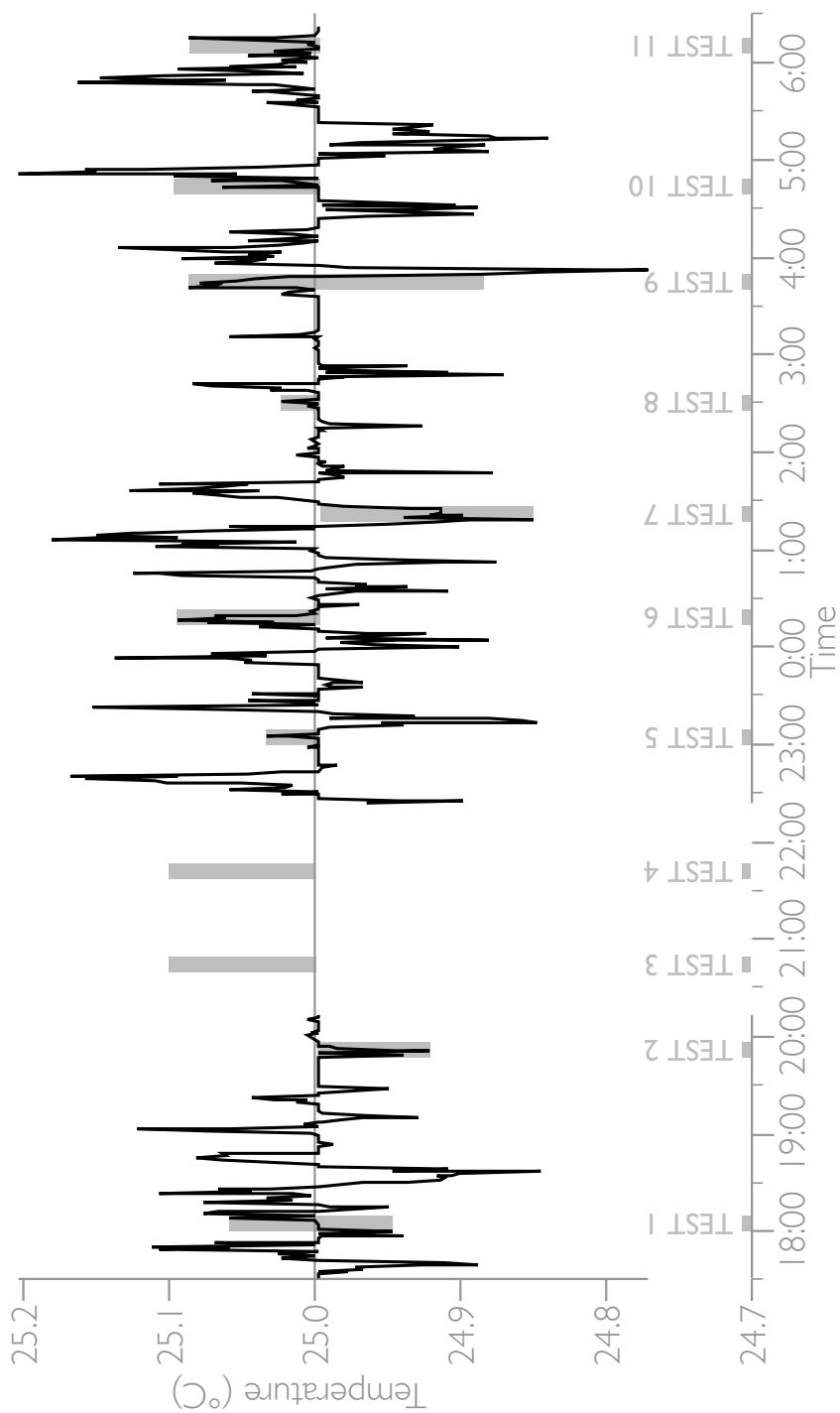

Figure 2.15: Temperatures recorded at the Air Handling Unit during the Cooling Fan Efficiency test. Observed temperature ranges are indicated by the vertical axis, time ranges by the horizontal axis. The test periods are indicated by the dark vertical bands, the width showing the duration and the height the temperature variation during that period.



perimental conditions (e.g. Clothing ensemble) we calculated  $h_{cal,i}$  using equation 2.3. The calculation uses the surface temperature ( $T_{sk,i}$ ) and power consumption ( $Q_{t,i}$ ) data for each body segment of the manikin collected during the three static (no fan operating) test runs. The equation divides power per unit area by a temperature difference, to yield a heat transfer coefficient with units  $\frac{W}{m^2 \cdot K}$ .

$$h_{cal,i} = \frac{Q_{t,i}}{T_{sk,i} - T_a} \quad (2.3)$$

We used equation 2.3 to calculate the Equivalent Temperature ( $T_{eq}$ ) for each body segment based on temperature and rate of heat loss. Equivalent temperature is defined as “the temperature of a theoretical uniform enclosure inside which a thermal manikin with realistic skin surface temperatures would lose heat at the same rate as it would in the actual thermal environment” (Tanabe et al., 1994). In other words,  $T_{eq}$  affords a way to reduce the complexity of the thermal environment to a single, albeit non sensory, temperature. This simplicity, of course, depends on the fact that the measurements are taken with the manikin and the fan in specific and fixed position and orientation, which does not necessarily translate well to actual human use. Following Schiavon and Melikov (2009b), we calculate the equivalent temperature for each body segment using equation 2.4.

$$T_{eq,i} = T_{sk,i} - \frac{Q_{t,i}}{h_{cal,i}} \quad (2.4)$$

In this equation,  $T_{sk,i}$  is the surface temperature measured for the  $i^{th}$  segment.  $Q_{t,i}$  is sensible heat loss (instantaneous power consumption) of that same  $i^{th}$  segment, and  $h_{cal,i}$  is dry-heat transfer coefficient calculated during calibration.

Finally, we compared the  $T_{eq}$  for each body segment during each test with the  $T_{eq}$  found for that same body segment in the tests with no fans running. The difference is a change in equivalent temperature ( $\Delta T_{eq}$ ) for that segment caused by the air movement produced by each combination of fan model and fan speed. The area-weighted average of the  $\Delta T_{eq}$  for each segment yields the equivalent temperature reduction in degrees Celsius for the whole body caused by the air movement. These are the results used to determine Cooling Fan Efficiency in equation 2.2.

### 2.5.3 Results

The cooling effect  $\Delta T_{eq}$  and fan power were obtained for each of the two fans under the experimental conditions studied; results are shown in table 2.7. The results indicate a whole body-cooling effect of approximately 1.2° C [2.16° F] for both speeds of fan version 2.4 and for fan version 4.3 at high velocity. The cooling effect for fan version 4.3 at low velocity is slightly lower at approximately 0.9° C [1.6° F].

The power demand for each fan was measured in two different ways. First, the voltage and current for each fan as an isolated component were measured at each speed setting.

Fan	Speed	Current (A)	Voltage $V_{dc}$	$P_{fan}$ (W)
2.4	High Velocity	0.27	12.00	<b>3.24</b>
2.4	Low Velocity	0.16	12.00	<b>1.92</b>
4.3	High Velocity	0.07	12.00	<b>0.84</b>
4.3	Low Velocity	0.04	12.00	<b>0.48</b>

Table 2.6: *Data and calculations for instantaneous power demand for the fans as individual elements in the CFE measurement.*

Instantaneous power for the fan alone, or  $P_{fan}$ , is calculated using these measurements and the formula  $P = I \times V$ , where  $P$  is power in watts,  $I$  is current in amperes and  $V$  is potential in volts. These values and the resulting calculation are displayed in table 2.6. This measurement isolates the fan power from that of the micro-controller, LED lights and the losses associated with the 120v AC to 12v DC transformer. As such, it represents only the work needed to physically move air. However, to compare this fan with those tested by other researchers, and to capture the complete—and necessarily larger—system power for the fan as a functional unit, the entire unit was plugged into a the 120V power source through an in-line watt-meter, which yielded a power demand for the complete system, or  $P_{system}$ <sup>1</sup>.

Fan	Speed	$\Delta T_{eq}$ (°C)	Fan Only		Complete System	
			$P_{fan}$ (W)	CFE	$P_{system}$ (W)	CFE
2.4	High Velocity	-1.18	3.24	<b>0.37</b>	5.8	<b>0.20</b>
2.4	Low Velocity	-1.20	1.92	<b>0.63</b>	4.0	<b>0.30</b>
4.3	High Velocity	-1.26	0.84	<b>1.50</b>	3.6	<b>0.35</b>
4.3	Low Velocity	-0.91	0.48	<b>1.90</b>	1.6	<b>0.57</b>

Table 2.7: *The results of CFE calculations using both the fan-only power, and the power for the complete system including controls, feedback and energy conversion.*

Using these data we calculated the Cooling Fan Efficiency for each fan version at both speed settings; results are summarized in table 2.7. The CBE personal comfort fans exhibited efficiencies ranging from  $0.3 \frac{^{\circ}C}{W}$  for version 2.4 at high velocity up to nearly triple that for fan version 4.3 at low velocity. These results are shown in figure 2.18 along with reference data for a number of other fan types drawn from Schiavon and Melikov (2009b).

<sup>1</sup>As indicated in table 2.7, Cooling Fan Efficiency was calculated using both  $P_{fan}$  and  $P_{system}$ , although for comparisons with other complete fan-systems, for example in figure 2.17, only the larger  $P_{system}$  will be used as it compares fans as a complete system on an equal basis.

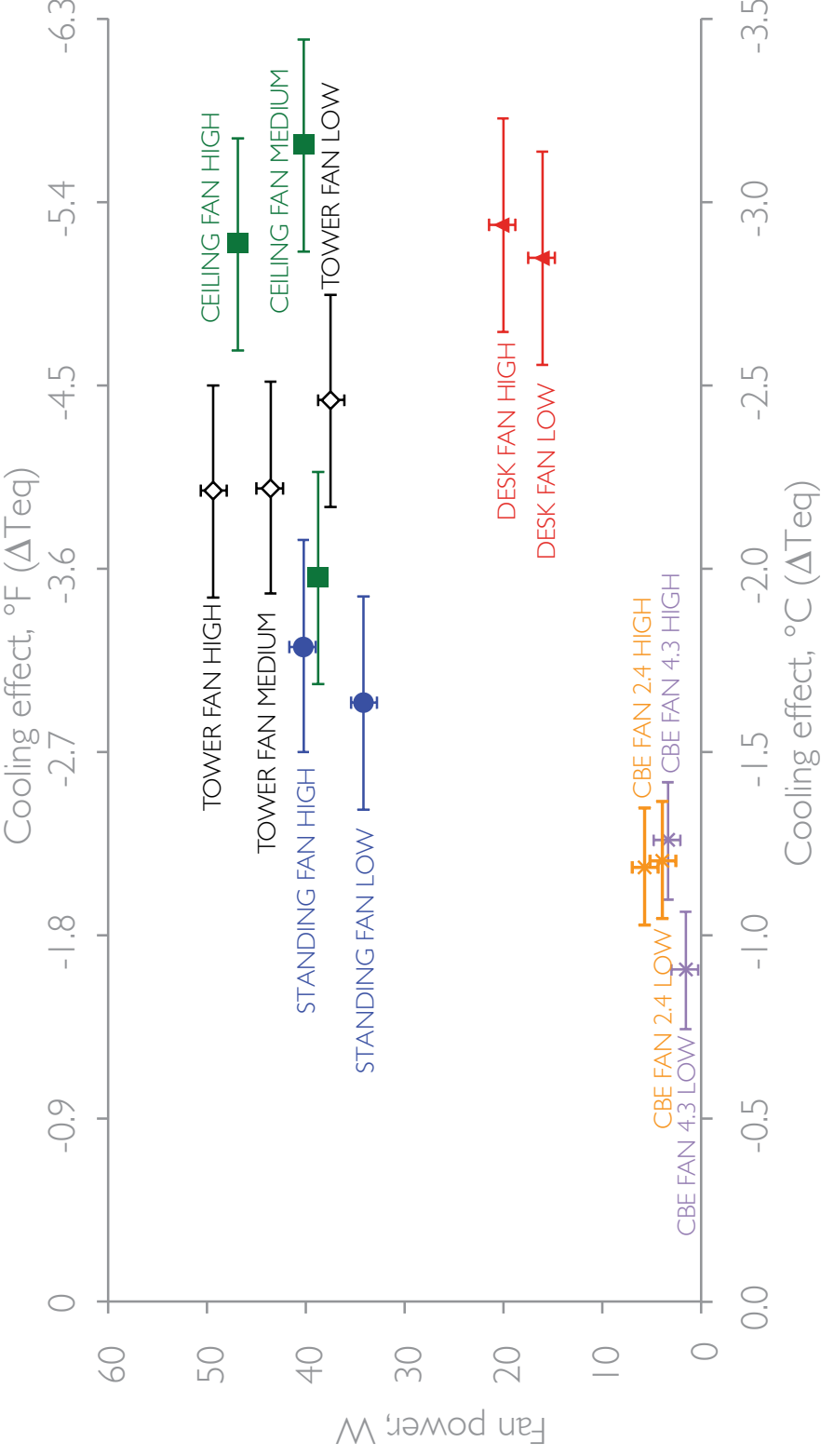

Figure 2.16: Graph comparing the CFE of the fan from the CBE personal comfort system to CFE data for other fan types calculated by Schiavon and Melikov (2009b).

Like Schiavon and Melikov we found that the increase in fan speed is always associated with an increase in energy consumption. Interestingly, and much like the previous findings, the increased speed did not always result in reductions in equivalent temperature. In fact, in the case of fan version 2.4, the  $\Delta T_{eq}$  is essentially equal at both speeds. This may be because the “speed” as used here is not a measure of the velocity in the air jet, but rather the rotational speed developed by the fan motor, so the airspeed that causes cooling at the manikin surface may not be very different. It is also possible that CFE is an imperfect measure for the highly-localized cooling approach studied here.

Thus far we have considered only the total or average  $\Delta T_{eq}$  however, the localized effects are perhaps more important to consider, so the equivalent cooling effect for each part of the manikin was calculated. These results are shown in figure 2.17. The cooling effect across various body parts differed from essentially none for the body parts located below the desk surface (feet and legs) through nearly  $6.5^\circ\text{C}$  [ $11.7^\circ\text{F}$ ] at the head.

## 2.5.4 Discussion

The slightly larger fan version 2.4, while producing slightly greater cooling effect, also consumes somewhat more energy, and therefore has an overall lower cooling fan efficiency than version 4.3. As noted, the low-velocity test actually resulted in a slightly (though not significantly) greater reduction in equivalent temperature than the high velocity. One important consideration is that in this test both fans were located fairly close to the subject, approximately 660 mm away. For fan version 4.3 this is 8.25 outlet diameters and likely inside a well-developed or developing air jet. However, for the larger fan version 2.4 this is only 5.5 outlet diameters, which may be inside the core zone, at least at the higher outlet velocity associated with the greater fan speed. See figure 2.5 on page 19 for a diagram of the zones of fan performance. Even leaving aside the effects of the development of the airstream, this close spacing does not take advantage of the longer range and throw made possible by the larger, more energy intensive fan version 2.4. Additional testing at multiple positions might reveal advantages for this larger design in terms of the greater flexibility in placement.

We compared these results to those found by Schiavon and Melikov as shown in figures 2.16. The first comparison shows that, while the CBE fan uses approximately one order of magnitude less energy than other desk fans, and far less than ceiling and standing type fans, it has a correspondingly lower total equivalent cooling effect. However, reframing this data in terms of Cooling Fan Efficiency—rather than its constituent measurements—results in figure 2.18, which compares the values for CFE. This is actually challenging as Schiavon and Melikov provides a figure with a maximum CFE of  $0.3 \frac{^\circ\text{C}}{\text{W}}$ , but three of the four conditions measured for the CBE fans reported CFEs greater than or equal to  $0.3 \frac{^\circ\text{C}}{\text{W}}$ , and one—fan version 4.3 at low velocity—very nearly doubles that value. However, with the graph extended, it is clear that the power consumption for the CBE

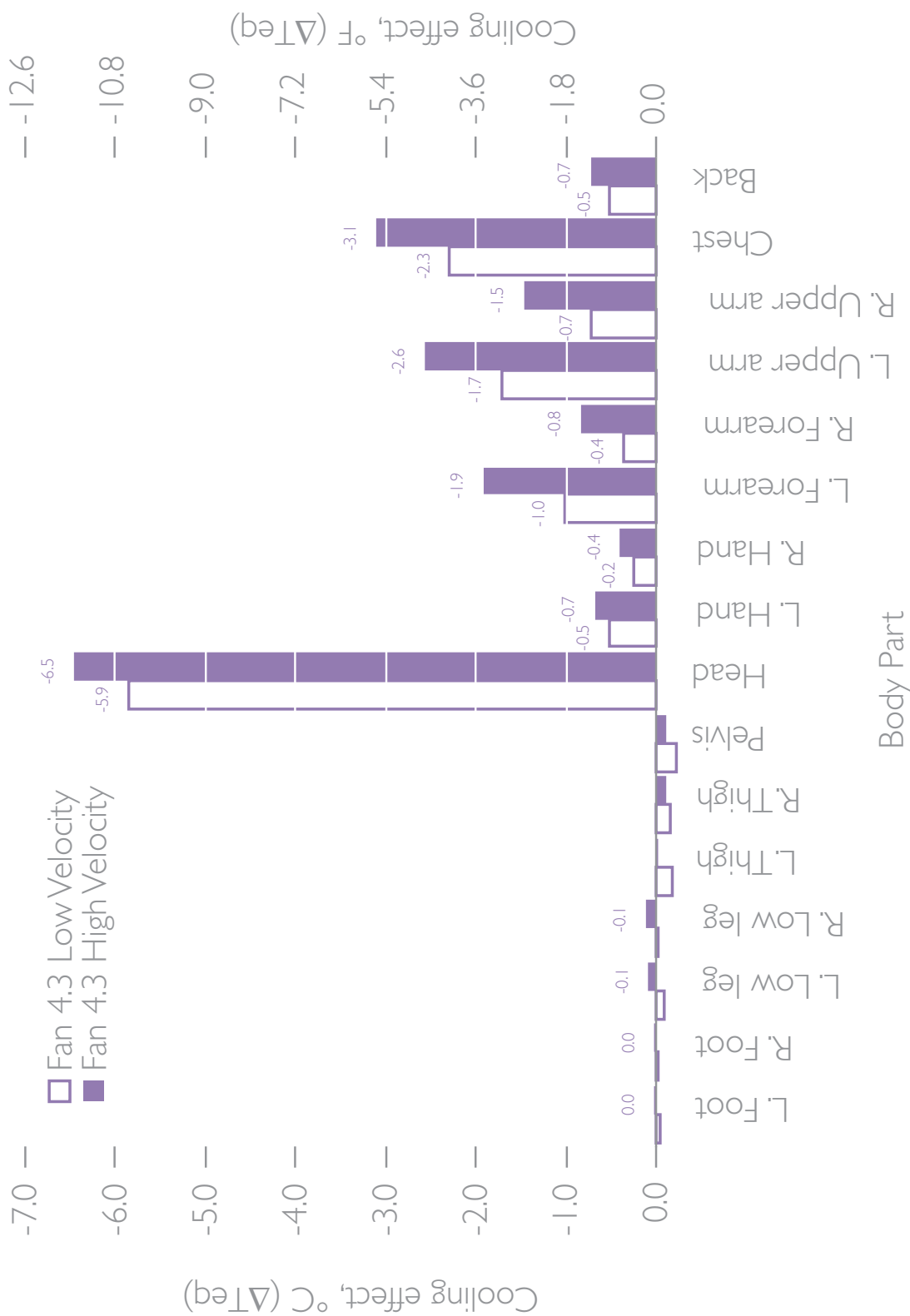

Figure 2.17: Because the CBE fan focuses on the head and neck, the cooling effect on those local parts of the body is substantially greater than the whole body cooling effect.

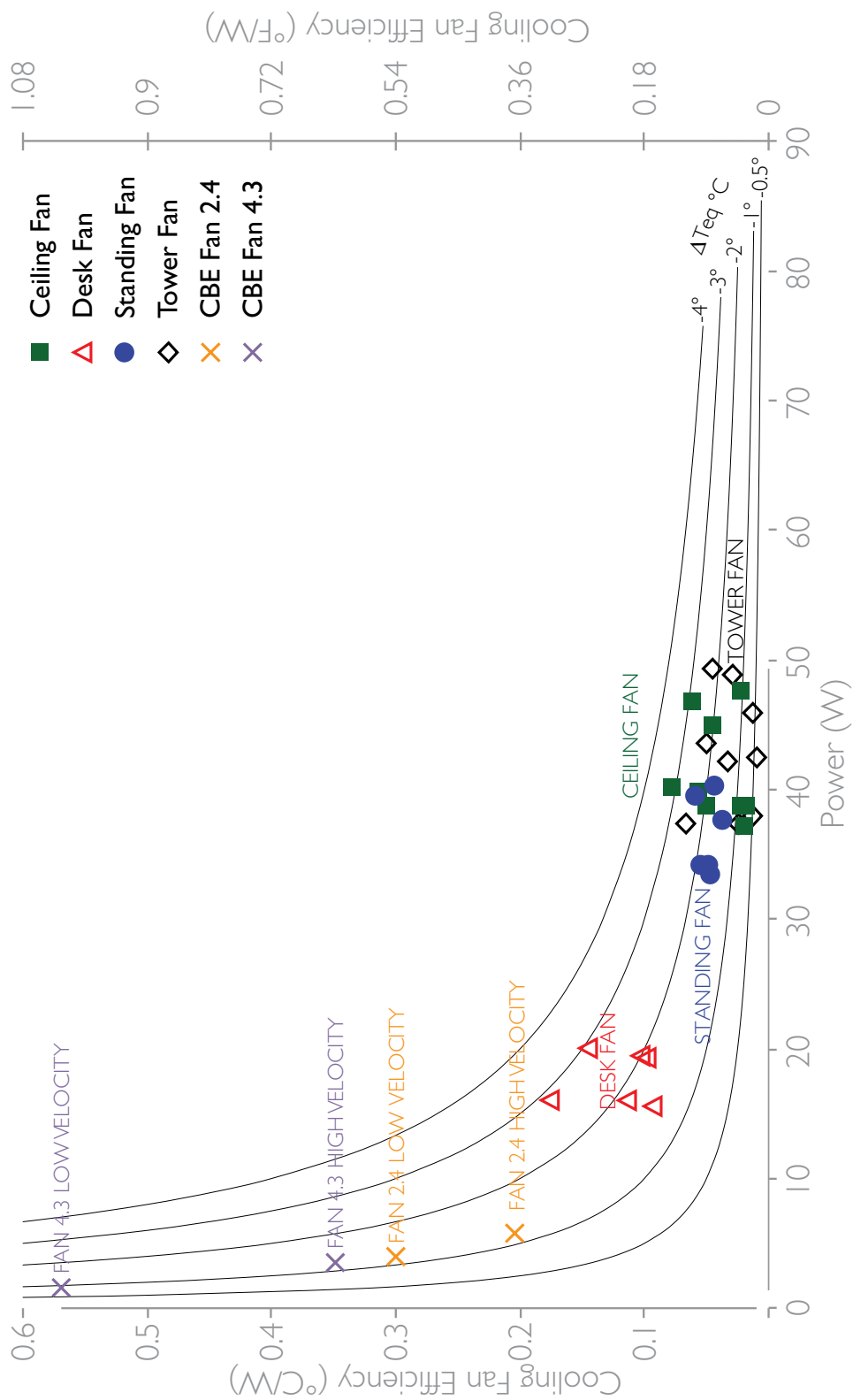

Figure 2.18: Cooling fan efficiencies as a function of power consumption for CBE fans and reference data (Schiaozon and Melikov, 2009b).

fans is dramatically lower (points are far to the left of the graph) while the reduction of whole-body equivalent temperature is in line with other fan types (points fall between the same or similar curves of equal  $\Delta T_{eq}$ ). As a result of comparable effectiveness and lower energy consumption, the cooling efficiency for CBE fans are greater than all the other fan types considered in this analysis (points are near the top of the graph). These findings suggest that very low powered fans placed in close proximity to the users with focused airflow on individual body parts offer an extremely efficient method for providing cooling and, by extension comfort, in overheated environments. These results are foreshadowed somewhat by Schiavon and Melikov who found that the desk fan was most efficient of the devices they tested, noting that,

“The DF is the most effective cooling device; its CFE (CFE = 0.123°C/W [0.221°F/W]) is more than double the index of the other fans (between CFE = 0.032°C/W [0.058°F/W] and CFE = 0.048°C/W [0.086°F/W]).” (Schiavon and Melikov, 2009b)

Interestingly, version 2.4 of the CBE fan averaged approximately double the efficiency of that desk fan (CFE = 0.252°C/W [0.454°F/W]) while the even more efficient production version of the CBE fan (v4.3) nearly doubled on that efficiency, with an average CFE of 0.459°C/W [0.826°F/W].

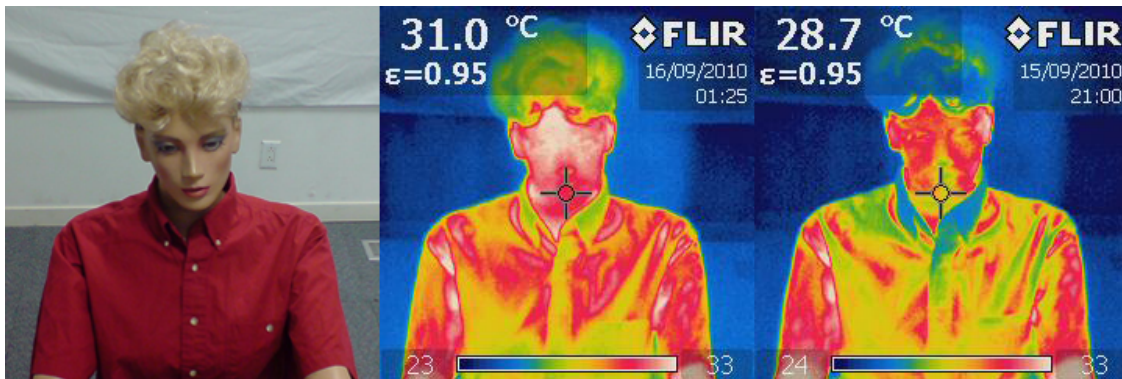

Figure 2.19: Photographs of the thermal manikin during CFE testing. The image at left shows the visible spectrum, while the infrared images are shown both without (center) and with (right) the CBE fan operating. Note the significant cooling of the breathing area of the head indicated by the yellow and green colors in the right image, and the 2.3°C reduction it measured temperature.

Furthermore,  $\Delta T_{eq}$  may not be the best metric for evaluating fans for personal control system because it necessarily includes the entire body. The CBE fan is specifically designed to focus on conditioning localized portions of the body (in this case the head and neck). Such local cooling may contribute to a sensation of human comfort and pleasure



without necessarily being reflected in the total cooling effect measurement. The term *aliesthesia* is sometimes used to describe the phenomenon by which people derive greater pleasure from stimuli the more they differ from the surroundings; as Cabanac, Massonnet, and Belaiche (1972) note in discussing the term, “A given thermal stimulus can feel pleasant or unpleasant according to its usefulness in restoring the internal body temperature to its set point”. Given previous findings (e.g. Zhang et al., 2004) about the influence of stimulus to the forehead, head and neck on overall comfort, these findings may underestimate the importance of the cooling effect provided by small local fans. These local effects on skin surface temperature of the thermal manikin are quite apparent through the use of infrared photographs, as shown in figure 2.19.

### 2.5.5 Outcome

The cooling-fan component of the CBE Personal Comfort System has a Cooling Fan Efficiency superior to that found using existing widely-available fans used for personal cooling. While the whole-body reduction in equivalent temperature is modest, the energy consumption is an order of magnitude lower than that of other fan systems. The resulting local fans have CFE values approximately two to four times better than other fan types considered. These findings suggest that small, highly-targeted fans provide more efficient cooling on an energy basis than do larger fans. These findings are useful in the design and development of optimal low-energy personal comfort systems, but do not suggest that other fans are inefficient or cannot be incorporated in this approach. On the contrary, cooling people using fans of even moderate CFE is far more efficient than cooling a whole building using an HVAC system that relies on vapor-compression cycles. As Hoyt, Arens, and Zhang (2014) note “the energy use of efficient PCS is almost vanishingly small compared to the energy use of central systems.” Furthermore, the CBE fan produces a pronounced and significant local cooling effect on the breathing zone which, while not counted in the CFE index, previous studies suggest will have disproportionate positive benefit for thermal comfort in overheated areas.

## 2.6 Final Design

In the fall of 2010, we finalized the design of the personal thermal control system and the component parts, and began placing orders for the parts needed to assemble enough fans to support the field testing.

### 2.6.1 Electrical Design

As the heart of the CBE personal comfort system, the fan device incorporates not only the electrical components to operate the fan; but also the controls for the footwarmer; as



well as sensors, communication, and data storage for the research agenda. As a result, the electrical design and wiring of the fan is somewhat complex. As a low-powered device, the entire fan unit, including the micro-controller for the overall PCS, runs on 12 volt direct current, which is simple to manage and quite safe.

The final design incorporated nearly 120 individual parts for the fan, including a number of delicate electronic sensors and controls. To ensure clear assembly, particularly for the complex wiring in the fan unit, we developed an illustrated circuit diagram, shown in figure 2.20. In addition to the circuit diagram, the complexity is perhaps best explained using a comparison of actual parts. Figure 2.21a shows the earliest working prototype on a breadboard while figure 2.21b shows the fan just before being closed up in final assembly

The fan itself uses a Pulse Width Modulation (PWM) signal to adjust fan speed, routed through a MOSFET to step the 0-X voltage signal up to a 0–12v as required for fan operation. Compared to other possible approaches to modulate the fan speed, this approach is simultaneously very quiet, and very energy efficient. To save even more energy, the cooling fan is designed to shut off automatically when the workstation is unoccupied. To detect occupancy for the fan, a Passive Infrared (PIR) sensor is attached in the stationary center hub of the fan, where it points directly at the subject, and is shielded from false-activation by the surrounding cowling. The occupancy sensor chosen for this system is the SB0081 PIR module, which combines a pyroelectric sensor module and a plastic fresnel lens with the necessary analog integrated circuit onto a single small-size printed circuit board which was connected through the flexible neck to the Arduino.

As a research instrument, the fan also housed sensors, in particular an ambient air temperature sensor. An Analog Devices TMP36 low voltage temperature sensor is mounted in the free airstream of the fan to record ambient air temperatures. The sensor ordinarily has a range from  $-40^{\circ}\text{C}$  to  $+125^{\circ}\text{C}$ , with output of  $10\text{ mV}/^{\circ}\text{C}$ . Taken together, this provides typical accuracies of  $\pm 1^{\circ}\text{C}$  at  $+25^{\circ}\text{C}$  and  $\pm 2^{\circ}\text{C}$  over the  $-40^{\circ}\text{C}$  to  $+125^{\circ}\text{C}$  temperature range<sup>2</sup>. The sensor provides a voltage signal for temperature. The voltage is read on one of the Arduino's AnalogIn pin (pin 0, in this case). This voltage is sampled every 500 milliseconds and converted into a temperature reading. The micro-controller processes these readings in several ways. First, it caches readings, and uses a moving-median to eliminate outliers and to condition the signal against noise caused by other components of the unit. In particular we were concerned about the possibility of current in the neutral ground wire caused by the PWM fan control adjusting the voltage from 0–5V as frequently as every 10 milliseconds. The window for this moving median is typically 120 samples, or one minute at 500 ms/sample. The smoothed reading is then adjusted based on calibration constants measured for the specific fan, a process described in 5.3.2, and recorded as the ambient air temperature.

---

<sup>2</sup>The TMP37 sensor would be a better selection because it offers the same 0–2 volt output range across a narrower temperature range of  $5^{\circ}\text{C}$  to  $85^{\circ}\text{C}$ . That range more closely aligns with the interior temperatures likely to be experienced by the CBE fan and increases precision by offering a  $20\text{ mV}/^{\circ}\text{C}$ . Unfortunately, we could not locate an adequate supply of these sensors at the time of fabrication.

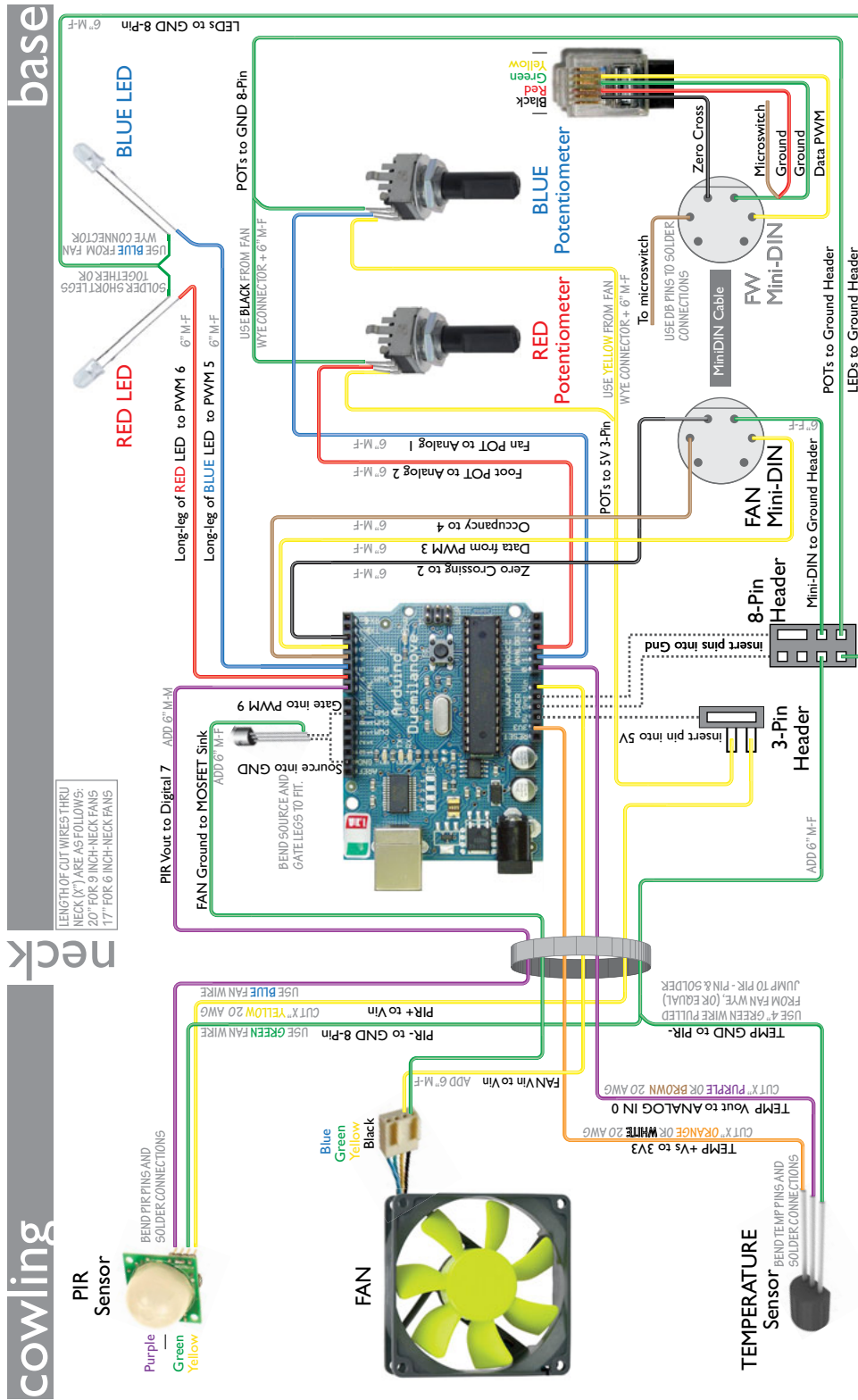
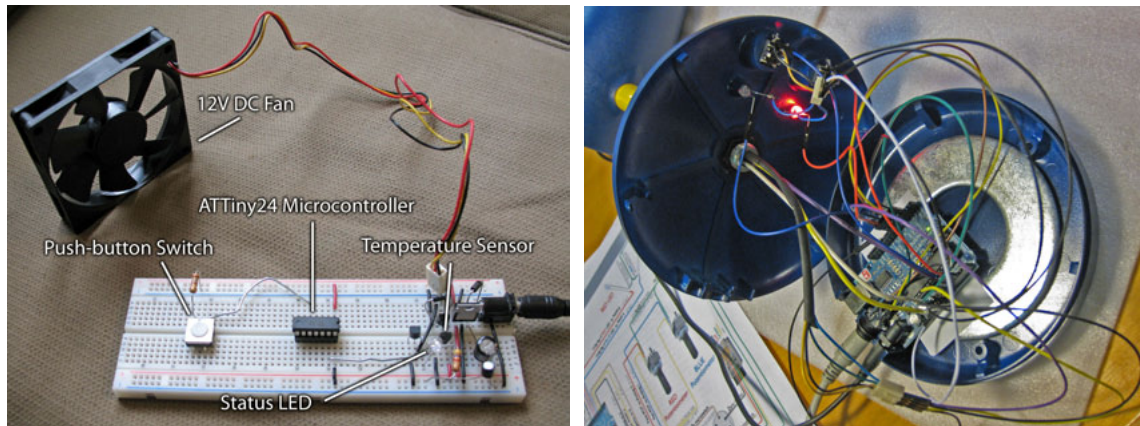

Figure 2.20: This diagram illustrates all the components and connections needed to complete the wiring for the fan, sensors and Arduino Microcontroller. It guided the assembly process for the full-scale fabrication effort.



(a) Early fan prototype wiring on a breadboard. (b) Wiring of the CBE fan just before final assembly of the base. Note circuit diagram

Figure 2.21: Comparison between early design and final wiring in the fan.

The sampling interval for all this data is adjustable depending on the intent of the study. For environments which seek to report every user interaction, relatively high sampling rates of thirty seconds or a minute might be appropriate. For studies interested in the longer-term trends of temperature and human response, sampling rates on the order of five minutes would be sufficient.

## 2.6.2 Plastic Parts and molds

The final shapes of the fan evolved over time for strength as well as ease of fabrication and assembly. With the aid of our manufacturing partner, Quickparts in Atlanta GA, we resolved multiple iterations of mold design, part draw and material flow analysis to optimize the parts for both intended service and ease of assembly, some of these analyses are shown in figure 2.22.

The whole assembly required stiffness in use, and durability, and was reinforced with internal ribs. The ribs were designed as a simple radial pattern of thicker plastic, although a refined design would make use of a narrower but deeper rib to optimize the material for strength and to aid in securing internal components or organizing the wiring to ease assembly. Many features were refined to support ease and reliability of assembly. On the cowling, there would be no access for tools, so the counter-bored hole had exactly fit the hexagonal panel nut that attached the gooseneck. Ultimately it also included a small hexagonal recess to hold the panel nut from the gooseneck in position and allow a very tight assembly without the need for a wrench. The base had to house the Arduino, allow the wired connections in the back to power the fan, connect via USB to the PC and also via mini-DIN cable to the footwarmer. This meant holding the plugs securely while leaving

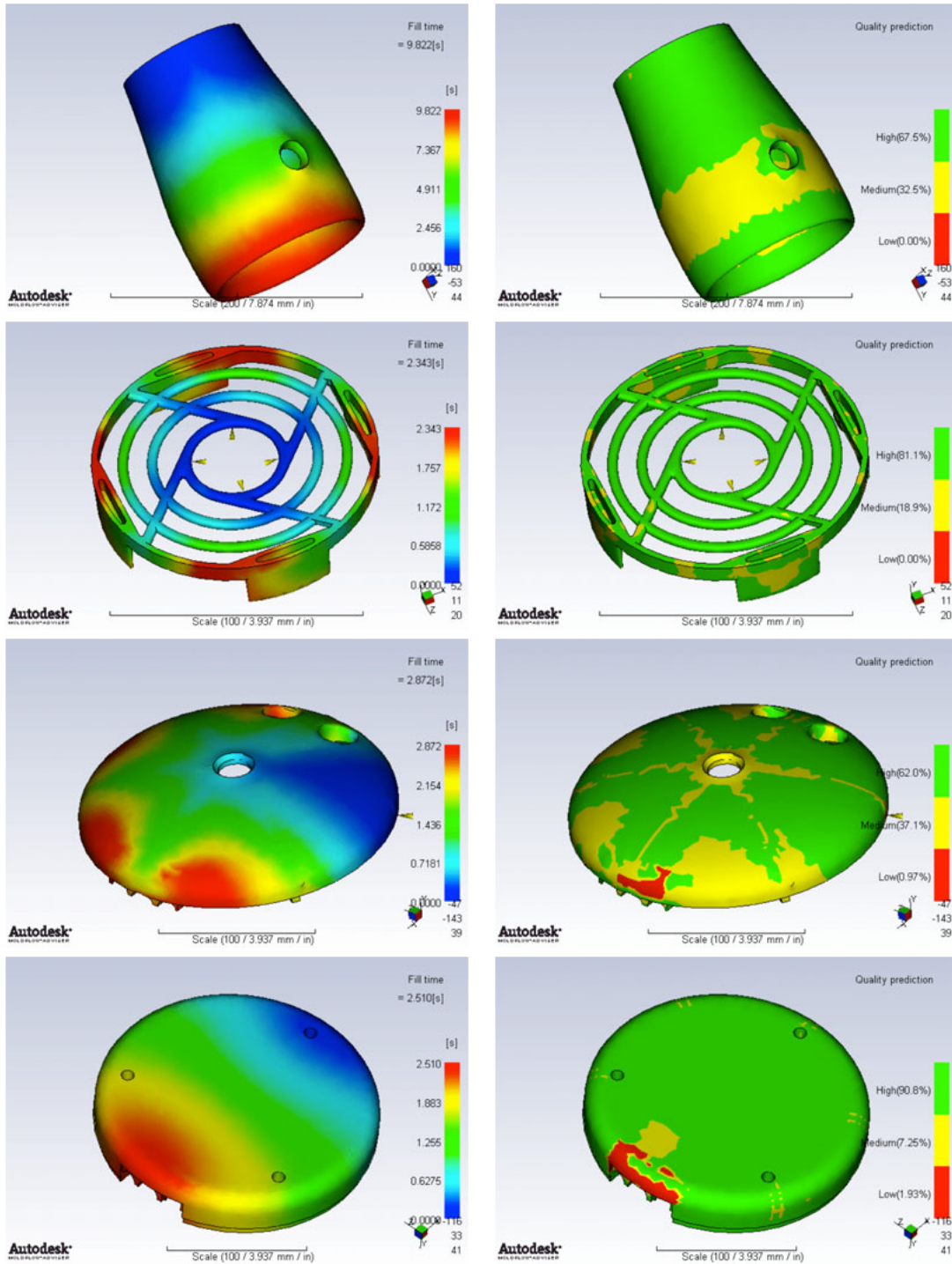

Figure 2.22: Design for Manufacturing (DFM) analysis of the injection-molded plastic components of the fan showing flow and quality.

room to insert and handle wires. The interior of the base included features to secure the LEDs in place with enough plastic to protect and remain smooth, but sufficiently thin to be translucent and maintain the correct color for signaling. The base also supported the potentiometers, which we wanted to submerge into the form of the base for aesthetics and human factors, but which also need to be accessible to install the potentiometers and their knobs. The shaft of the potentiometer is secured from the inside with a locknut requiring clearance for a wrench inside and a socket on the outside. Meanwhile, the knob that attaches to the shaft is secured with a set-screw from the exterior, requiring access for a small hex wrench on the front edge. These critical dimensions were built into the parametric SolidWorks model to ensure adequate clearance.



## Chapter 3

# Footwarmer

To provide heating in cool conditions, the PCS targets the feet using an efficient radiant footwarmer.

### 3.1 Footwarmer Background, Problem, and Objective

Observing that in transient warm or cool environments the application of cooling or heating to the the hand, forehead and neck offer well-documented improvements in local thermal comfort compared to neutral conditions, Zhang et al. (2004) found similar effects for the feet. Evaluating their findings from thirty tests warming and cooling the feet, they note that “The ‘very comfortable’ votes occurred when the whole body was warm or cold and the foot was cooled or warmed in the opposite direction to relieve discomfort.” These findings directly influenced the foot-warmers used in Zhang et al. (2010a), which consisted of an insulated box warmed by a 125 W reflector heating lamp. While this is a fairly high-powered device, it is about an order of magnitude less than a typical electric space-heater that might be found under an office desk. Furthermore, the researchers found that since the device could be cycled to provide partial rates, it seldom ran at full power, noting “At room air 18 °C, our subjects selected an average radiant flux of 30 W and an internal air temperature of 32 °C.” (ibid.). These lab results suggested that providing local warming to the feet could be an effective approach for a personal comfort system, but unfortunately, no such device existed on the market. To demonstrate the practicality of this approach, we set out to develop an effective, user-friendly and low-energy foot-warming device that would be sufficiently robust and attractive for use in office environments and capable of being produced at a reasonable cost. The objective here was to demonstrate eventual market acceptability, and more immediately, support the field study research by deploying a large number of PCS within a limited budget.

## 3.2 Form and Function

After considering a range of strategies such as radiant panels, ceramic heaters, and conductive pads, we determined to continue with the basic design of the footwarmer box Zhang et al. (2010a) used in the lab tests, including using electric lamps above the feet as the heat source. Heat lamps offered four main benefits: first, they used radiant heat transfer which is an effective and comfortable mechanism; second, they offered straightforward and linear part-load control through dimming or cycling; third, bulbs use an extremely hot but low-mass filament (compared with larger or more massive heating elements) offering very quick response; and fourth, the bulbs are available with built in metallic reflectors to direct the beam where needed.

While other personal thermal controls include radiant warming as a strategy—for example, the Johnson Controls Personal Environment Modules—they had much lower efficiency because the heating panels were large flat panels at lower temperature, meant to address the feet, legs and lap. The relatively large thermal mass of these panels also limited the speed with which they could act to warm or cool. In contrast, the approach piloted in Zhang et al. (*ibid.*) focused a 125 Watt lamp on the feet directly, and contained the warm air and the radiation in an insulated enclosure. The insulation reduced all three methods of heat transfer, with rigid foam reducing conductive losses, a foil lining reflecting the radiation and a small cloth curtain preventing warm air from convecting out of the enclosure. Furthermore, heating the top of the feet worked fairly well even with shoes, while the heating by conductive footpads is largely slowed and reduced by the insulating sole of a shoe.

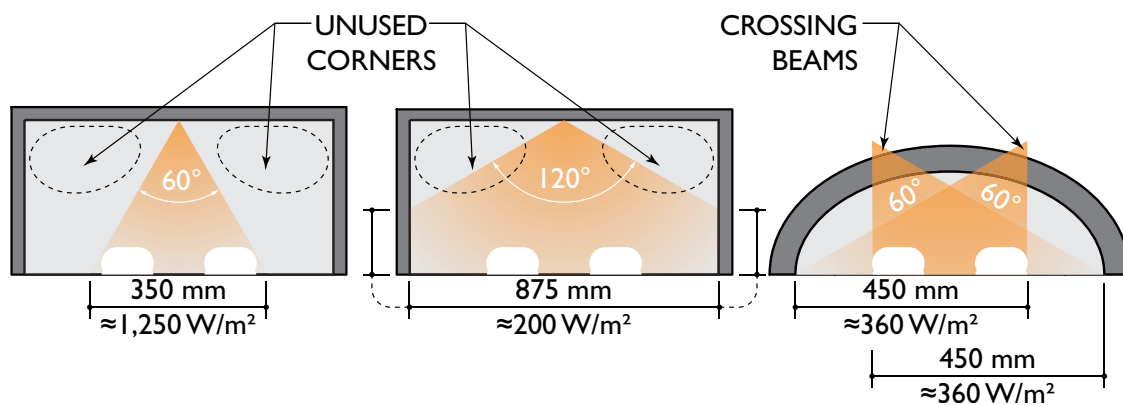

Figure 3.1: Cross-sections of hypothetical arrangements for lamps. Narrow-beams in rectangular enclosures (left) have unused air volume at the top corners and poor radiation coverage. A wide beam spread can address coverage but reduces the energy intensity. The crossing beams of the elliptical geometry eliminate corners and provide full coverage.

The first new prototype built in spring of 2010 followed these main precepts while

seeking a more elegant form, and improving the focus of the lamps onto the feet. We developed an extruded half-ellipse shape that would arc over the feet. The goal of the design was to eliminate the unused top corners, providing a wide floor area for the feet to move, with minimum air volume. We considered but did not adopt a simple arc or part circle as the resulting shape sloped too steeply near the ground, reducing the effective width of the device. This shape also afforded an opportunity to focus more of the radiation from the lamps onto the feet by inclining two lamps. These geometric considerations are shown in figure 3.1. This form was fabricated using a stressed-skin composite panel with reflective aluminum skins and a foamed-in insulation core. Because elliptical geometry can be difficult to fabricate (although perhaps less so with modern CAD/CAM technologies) we decomposed the shape into three part-circles arcs. The fabrication process is illustrated in 3.2. Thin metal sheet was draped into the concave form and over the convex one and secured with double-stick tape. The two mold halves were clamped together to resist the pressure of the expanding foam insulation, which was placed in the cavity in several layers. Once the foam had cured, the clamps were removed and excess foam trimmed away, see figure 3.2b. The shape and manufacturing method provided a extremely rigid structure for the device. The composite arch actually supports all the other materials including the back, which hangs from it, see figure 3.2c. The material choices also integrated the insulation and structural requirements into a minimal, elegant form. The rear face consisted of an insulated vertical panel, while the front was cut back somewhat at the top to avoid contact with users' shins when the feet were inserted. This front face was also cushioned with a soft foam bumper as shown in figure 3.2c.



(a) The metal and foam composite shell in the wooden formwork used to create it but with clamps removed.

(b) The front face of the footwarmer is cut back at an angle to accommodate users' shins. Note the tapered angle of the resulting scrap in the foreground.

(c) The final shell is strong and rigid, and supports the other components of the footwarmer. Note the soft foam bumper and the holes ready to receive lamp housings.

Figure 3.2: *Fabricating the composite elliptical footwarmer*

In this prototype, the lamp housings were allowed to protrude to the exterior through holes cut into the surface of the shell. This design had the effect of recessing the lamps from



the interior into the thickness of the shell, which would prevent users from kicking or getting burned accidentally. The increased distance from the feet also slightly increased the beam spread area to provide complete coverage. Each circular housing contained a single 60 watt heat lamp aimed down and to the side. The final result of these arrangements made the exterior of the prototype look slightly odd (some users compared it to a frog). The lamps were wired together in parallel, and connected to a dimable power supply, to provide users part-load control. Interestingly, the heat lamps were red in color, a feature to which many users responded favorably, comparing the warm glow under the desk to that of a fire. This glow is visible in figure 3.3 which shows the complete footwarmer in use.



Figure 3.3: *A user's feet partially in the elliptical footwarmer.*

The warming effect is visible in the infrared thermograph in figure 3.4, which shows the footwarmer under one of the prototype desks with conductive surfaces.

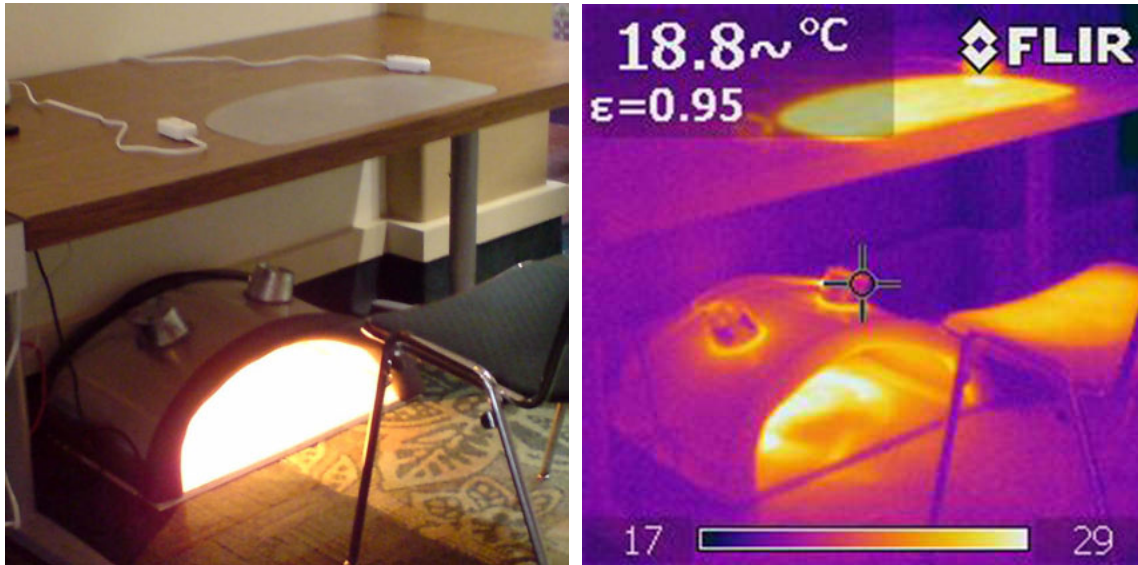

(a) Visible image of the complete footwarmer. (b) Infrared image of the footwarmer operating.

Figure 3.4: Visible and infrared images of the footwarmer in use under a desk.

### 3.3 Housing and Manufacturing

In parallel with the development and design for manufacturing of the Fan, the footwarmer was also refined and developed for manufacturing a large number of prototypes. One of the primary design constraints was ensuring the safety and durability of the device when placed under the desk. Given the use of higher voltage, the possibility for rougher treatment from users' feet and furniture we determined that a significantly robust material was required, in this case heavy-gauge sheet metal. Based on the experience with the previous arch-shape footwarmer prototype, manufacturing a large number of prototypes would require a simpler design, without the complexity of the foam composite panel and complex elliptical geometry. Furthermore, user observation suggested that more than depth or height, the critical dimension for user experience was the width, and ability to move the feet from side to side to different locations inside. As a result of all these factors, the design developed into a bread-box shape, an early cardboard design mockup of which is shown in figure 3.5. The unit is just under two feet wide so as to fit into even the narrow leg opening of a Steelcase "tanker" desk. This more spacious rectangular opening gave users the full width to their feet side to side. This design retained the lamp placement from the elliptical footwarmer, with reflector lamps at the top corners aimed to provide crossing beams across the entire floor. We determined to make the entire floor of the footwarmer a pressure or switched sensor to detect the presence of a foot, rather than rely on IR or other non-contact devices. The gentle curve on the top of the footwarmer would act as footrest and discourage users from placing objects on the top of the warm box.



Figure 3.5: *Early functional cardboard prototype of the final footwarmer shape being tested to refine dimensions and arrangement.*

Based on the development of the cardboard models, we produced detailed fabrication drawings, shown in figure figures 3.7 and 3.8, and then worked with a local metal fabrication shop to build a working metal prototype. The first mockup was hand-built in raw steel to develop the design and the manufacturing techniques, tools and fixtures. This prototype is shown along with Amador, the craftsman who made it, in figure 3.6a, and undergoing structural testing in figure 3.6b. The final footwarmer design follows this mockup fairly closely, although with some modifications. Working directly with the machinist, and the engineering staff at the fabricator, we refined the design for ease of production and safety and durability of the final product. This included separating the bottom and top assemblies with a seam to ease the fabrication, and the addition of a welded steel rod in front of the lamps on each side. While this bar made installing and removing the bulbs slightly more difficult, it protected the bulbs from being kicked, and users from accidental contact with the hot lamp.

Because the footwarmer was made out of folded sheet metal, a major aspect of the design is the layout of the shape, the bends and folds, welding points and above all the arrangement of correctly-sized openings for the lamp holders, the power and data cords, and the threaded inserts. As shown in the CAD drawings in figures 3.7 and 3.8, there are four main components: the complete shell with curved top, the left and right side panels that support the lamps and protect the electronics, and a large, spring-loaded floor plate, which acts as a switch to detect the user's foot. Each of these primary components features threaded inserts to permit rapid assembly using machine screws. The machine screws that hold the assembly together enter from the bottom of the device, and each also attaches a low-profile rubber foot to prevent the box sliding when placed on carpet, and to protect floors from scrapes or damage by the box. The metal parts also have various punched and





(a) The first metal footwarmer prototype with Amador, the machinist who built it. (b) Testing the strength of the metal footwarmer prototype.

Figure 3.6: The first sheet steel footwarmer prototype

drilled holes to support the other components. The mini-did plug was threaded and held in place with an included panel nut, while the 120 volt power cord was supported by a nylon strain-relief block, which protected the cord from wearing on the sharp sheet metal edge, and snapped into a correctly-sized rectangular hole. The x10 modules and other wiring were designed to tuck into the space between the right-hand side panel and the exterior of the box, and were affixed with a thick double-sided tape. These parts are visible in the assembly photographs in figure 3.9. Also visible is a copper grounding plug secured to one of the assembly machine screws. This connection between the metal footwarmer body and the grounding pin of the electrical system grounds the appliance and helps reduce the risk of shocks in an over current or short-circuit situation.

When the design was finalized, the main components were fabricated from 18 gauge steel. The fabricator powder-coated the parts prior to delivery, which provides a durable, scratch-resistant coating that is not affected by the temperatures of the box. As shown in figure 3.9 the fabricator produced and delivered parts for 105 footwarmers in two colors. In addition to the sheet metal, the shell was designed to accommodate a flexible insulation called Prodex, which features reflective aluminum foil faces on each side of 13/64 inch closed-cell polyethylene foam. The material is sold in long rolls and cut to length and press-fit into the box during assembly, which is also visible in figure 3.9. Two layers were provided on the top and back, and a single layer on each side behind the lamp holders. The foil reflects radiant energy, while the closed-cell foam reduces conductive losses. In some initial tests a few users reported a burning odor, and while we could find no damage to the insulation in the units, out of an abundance of caution, we added shields made of aluminum flashing to protect the insulation near the lamps.

Originally, we thought the floor plate would need springs to hold it in the “up” posi-

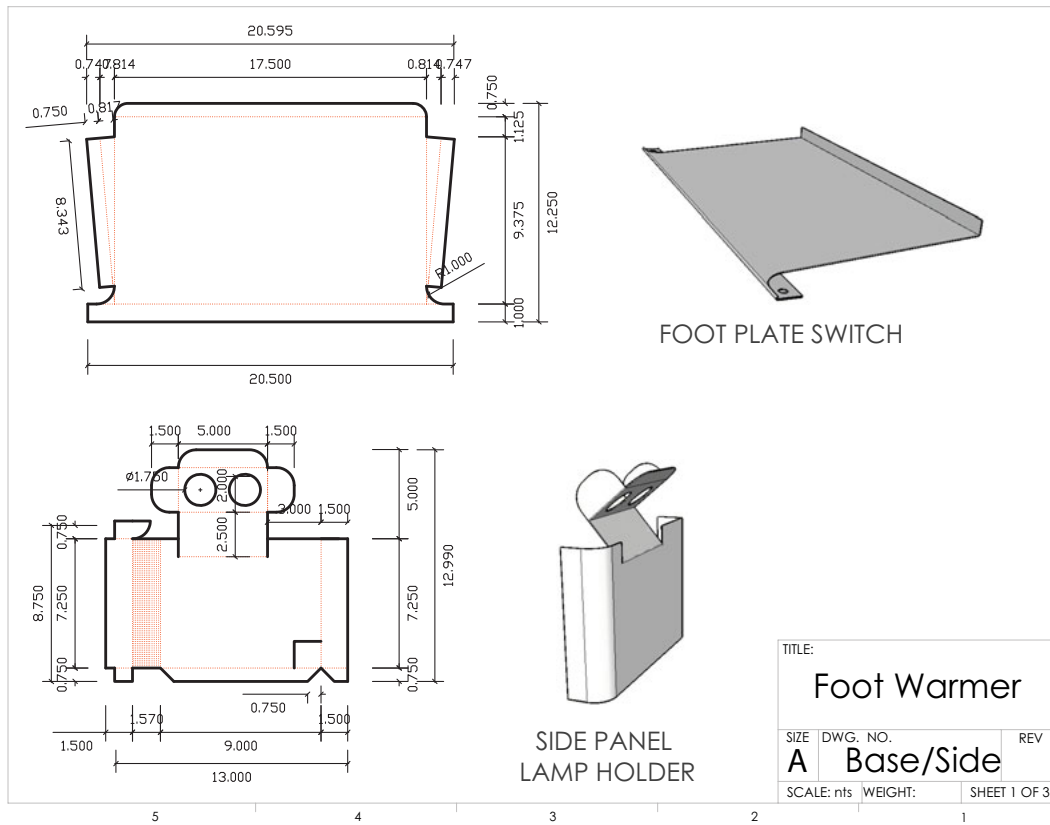

Figure 3.7: CAD drawings of the lamp holder and footplate parts.

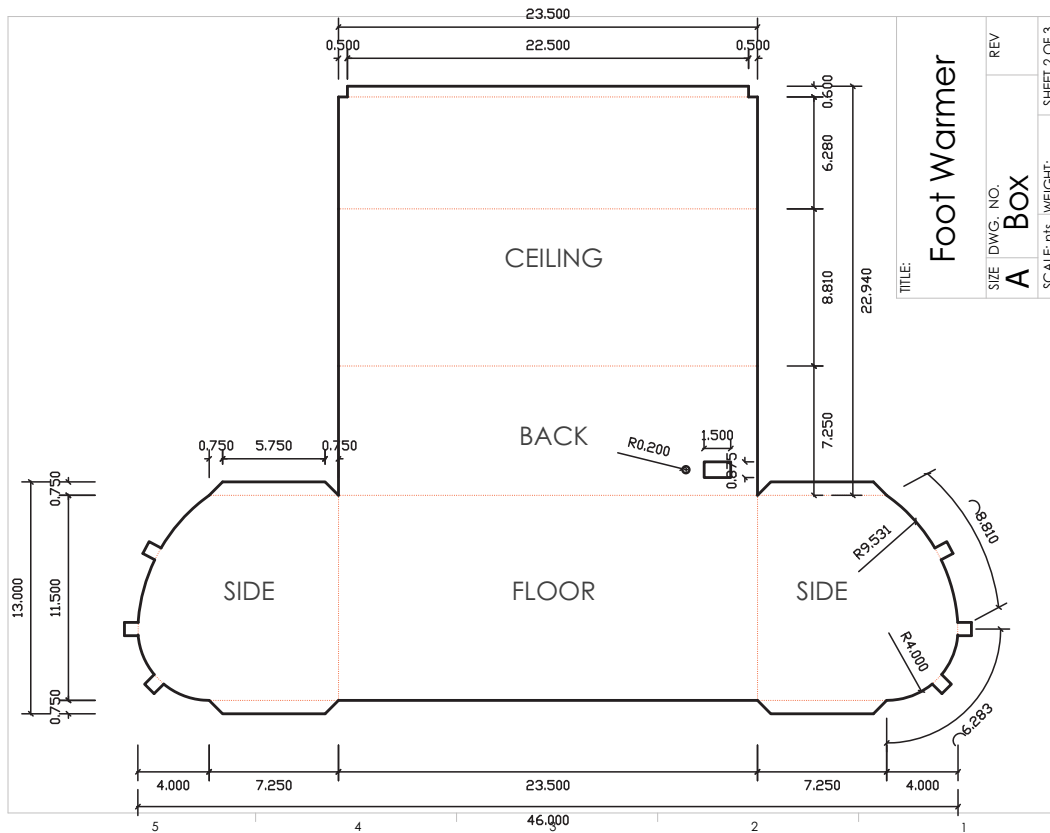

Figure 3.8: CAD drawings of the box enclosure.

tion until the weight of a user's foot pressed it down, activating the footwarmer. However, we found that with an appropriate fold, we could use the elasticity of the steel plate itself to hold the plate in the normally open position. To detect occupancy, the moving floor plate triggered a momentary switch with a long arm. To locate the switch in the correct position, it was mounted to holes (with threaded inserts) on one of the side panels, and the arm of the switch could also be bent to fine-tune the sensitivity of the plate. Original design sketches called for two switches (one on each side) but by bending the back of the footplate up, it became sufficiently rigid that only one switch was required. We did provide small springs to prevent the plate traveling too far and bottoming out, which could potentially damage the switch if a user's feet pressed down too hard.

To protect users' shins and increase comfort, the top edge of the front opening was protected with an L-shaped rubber bumper, held on with automotive-grade double stick tape. This lip also provided a strong capture for the edge of the aluminum insulation, and a location to attach a future curtain of cloth or ribbon to further improve the heat retention inside the footwarmer, although this was not implemented at the time. One important discovery was that the powder coating made the material so smooth it was difficult to secure the threaded lamp-holders and mini-DIN panel nuts without the fixtures simply rotating. To solve this, we used a punch to provide a small dimple adjacent to each lamp-socket hole, but a refined design would add this in the factory assembly.

### 3.4 Electronics

Unlike the fan, the footwarmer, required significant power for the resistance elements that produced the radiant heating, approximately 160 watts, or two orders of magnitude more than the fan at peak operation. Since power is a function of both current and voltage, both would increase to meet this demand and the footwarmer was built around a 120 volt alternating current standard. This fundamental electrical difference between the two parts of the system demanded careful design to protect the users and the system from the danger of the higher voltage and current. So, while somewhat simpler electronically, the footwarmer also had a number of critical parts and, since the voltages were significantly greater, required careful attention to ensure safe and reliable operation. The sketch in figure 3.10 shows the relative arrangement of these parts. Perhaps most importantly, we determined to use off-the-shelf UL-listed components to control the footwarmer, rather than design and build our own. We adopted the x10 automation platform for control because it offered an affordable, modular and compact set of components with the needed performance.

The x10 is designed as a robust home-automation platform. In typical use in buildings, x10 transmits control information over the existing regular electrical lines. Before widespread wireless, the x10 system allowed control without additional wires in homes (for example to turn on and off all Holiday lights simultaneously from a single location).



Figure 3.9: Images showing the fabrication, components and assembly of the footwarmer.



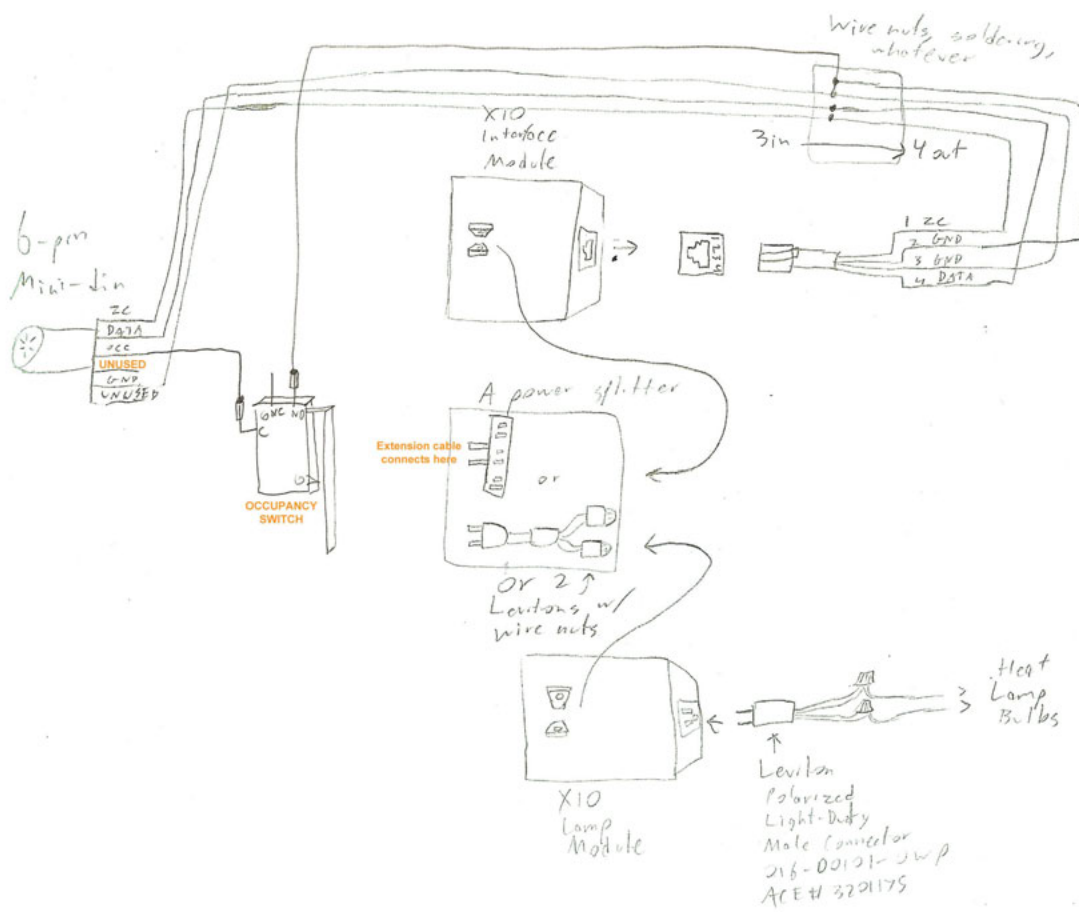

Figure 3.10: Sketch of the components and circuits in the final footwarmer.

The protocol takes advantage of the fact that on alternating current mains, the voltage cycles from positive, through zero to negative, then back through zero to positive. In the USA a full cycle happens 60 times each second (60 Hz), which means there are 120 so-called “zero crossings” every second when the voltage is zero. The x10 protocol introduces small pulses of voltage at the zero crossings to signal ones and zeros, and thereby transmit binary data. The small increases are far less than the voltage cycles (on the order of 5 volts) and do not unduly interfere with other devices on the circuit (although they introduce noise). Numerous components of the x10 system are available to interface with or control various devices. Of particular interest to us was a reasonably-priced lamp-control module that allowed for continuous dimming.

To take advantage of this, we<sup>1</sup> developed an interface whereby the Arduino microcontroller could introduce signals to the 120V circuit connecting three x10 modules inside the footwarmer. Signals controlling the footwarmer are sent via a 6-wire mini-DIN cable from the fan to the footwarmer. A custom-built adapter connects the mini-DIN plug into a 6-wire phone type plug, which in turn is connected to an x10 interface module. The interface module takes the low-voltage control signals coming from the fan base, and converts them to x10 signals on the 120 volt circuit connected the heat lamps. In this case the circuit was small, consisting only of a very short multi-outlet power cord, into which was plugged a dimming lamp control module located inline between the heat lamps and the power source. This control module read the x10 signals and modulated the current to the lamps in order to turn them on, off and adjust their intensity. To prevent the signals from escaping, the third x10 module, a filter, isolates the circuit inside the footwarmer (the single power strip) from the wall outlet. This helps reduce noise on the circuit for the rest of the building, and ensures that multiple PCMs on the same building circuit will not end up accidentally controlling each other.

Like other components of the PCS, the footwarmer is designed to shut off automatically when the workstation is unoccupied. To detect use of the footwarmer, the entire bottom plate of the footwarmer hinges slightly down when the subject places their feet inside, activating a switch which closes a circuit to the Arduino. Just as with the sensing, control, and feedback wiring in the base of the fan unit, the x10 control modules and microswitches in the footwarmer needed to be wired for safety and correct operation. State and control signals were communicated between the footwarmer and the fan via a cable with 6-pin Mini-DIN connectors at each end. One was wired into the Arduino, the other was wired into a standard RJ-11 telephone jack plugged into the x10 interface module. These connections are illustrated in figure 3.10.

---

<sup>1</sup>As noted in the Acknowledgements, the research team included Ryan Luecke, a gifted electrical engineering and computer science student who originally suggested the x10 system. Without his creativity, hard work, and willingness to experiment, the electrical design, PC client software, and network security protocols would not have been possible.

# Chapter 4

## Conductive Surface

In addition to work on localized comfort strategies for the face and feet, we explored strategies targeting the hands and wrists.

### 4.1 Surface Background, Problem, and Objective

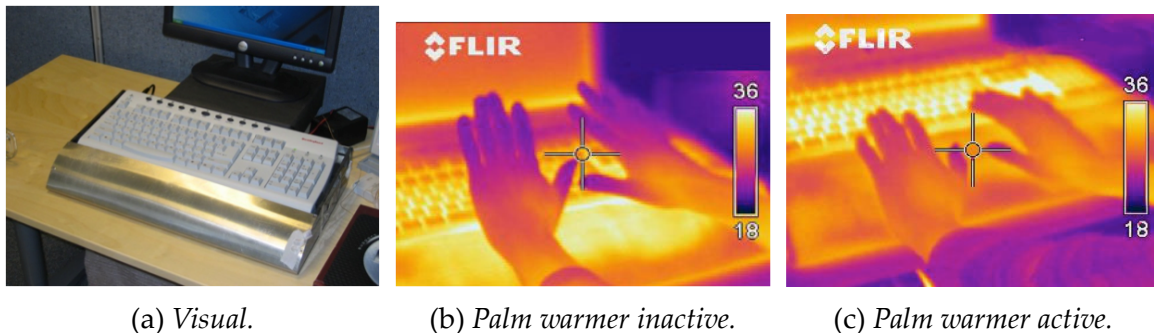

Figure 4.1: *The conductive aluminum palm warmer and integrated heated keyboard used by Zhang et al. (2010a)* Note that emissivity means the infrared images of the metallic warmer are spurious, but the impact on the hands is correct, and easily visible.

This investigation harnesses the thermal sensation and thermal comfort effects of providing warm hands in cool conditions and preventing sweaty hands in warm conditions. Previous work (e.g. Attia and Engel, 1981; Cabanac, Massonnet, and Belaiche, 1972; Mower, 1976; Zhang, 2003; Zhang et al., 2004) indicated the sensitivity of the hands and wrists to local thermal stimuli, and the subsequent effect on overall satisfaction with the thermal environment. These findings suggest that targeted conditioning of these areas counter to ambient conditions increases the range of ambient temperatures which occupants find comfortable. Zhang (2003) found that warming the hands and wrists was the second most

effective strategy (after feet) for expanding the lower end of the comfort range; and that cooling the hands and wrists was the second most effective strategy (after the face) for expanding the upper end. These findings suggest that devices to heat and cool the hands and wrists should be considered as part of a personal comfort system. In a controlled environmental chamber study, Zhang et al. (2010a) used an aluminum palm warmer attached to the workstation keyboard much like an ergonomic wrist rest and heated to about 35°C to provide local warming, as shown in figure 4.1. The device used electric resistance tapes and drew about 26 watts. For cooling mode, that same device incorporated three small fans (approximately 2 W each) that directed a curtain of air across the keyboard surface. The results using this simple initial device demonstrated promise for this approach. They also prompted this effort to demonstrate design approaches integrating hand warming and cooling into the furniture (work surface) rather than the technology (keyboard). Unlike the fan and footwarmer the objective here did not include producing a large number of devices for a field study (which would have been both cost prohibitive and disruptive to the office environments in which we hoped to conduct our testing). Instead, this effort focused on proving the concept of integrating the worksurface into the PCS.

## 4.2 Design Concept and Testing

As described previously, these designs built on the approach developed and tested by Zhang et al. (*ibid.*) for the “palm warmer” and “hand ventilation” devices tested in the low-energy TAC system. However, rather than integrate the device with the keyboard and provide air movement for cooling, the conductive surface area was incorporated into the desktop of the workstation itself. The size of the conductive surface was increased to cover more of the work area, and intended to provide a cooling sensation through conduction only when the user placed hands or wrists on the surface. In total, three desks with conductive work surfaces were developed, and are shown in figure 4.2, taken at an April 2010 meeting of the Industry Partners for the Center for the Built Environment. All three designs incorporate highly conductive materials (e.g. aluminum plate) into the desktop in order to passively draw heat away from the hands and lower arms during the overheated period, but there are particular variations to explore the various design alternatives and opportunities.

The first, shown at the far right of figure 4.2 and in detail in figure 4.3a, is a thick aluminum plate set flush with the desk surface, with the back completely exposed to room air. This device cools by conducting heat away from the hands and wrists and to the cooler air, and heats via user-controlled electric resistance elements attached to the underside of the plate. These integrated electric resistance heating elements warm the lower arms and wrists in cool periods, and are designed to prevent the plate from growing so hot as to be dangerous, or placing undue strain on sensitive electronics like a laptop.

The second desk, shown at the far left of figure 4.2 and in detail in figure 4.3b, is com-



Figure 4.2: The three prototype desks.



pletely passive. In this case the metal plate is laminated to a thin plywood surface, and the laminated panel rests flush with the rest of the thicker plywood desk surface. In overheated period, the conductive plate is still fairly efficient at conducting heat away from the skin, even though the underside is not exposed. To avoid the undesirable cooling in the underheated period, the user can simply lift out the laminate panel and flip it over to expose the wood side. This less-conductive wood surface adds no additional heating, but does avoid the conductive loss by insulating the wrists from the aluminum plate.

The third prototype is designed as a work surface for systems furniture, as shown at the center of figure 4.2 mounted to a small section of cubicle wall divider. This conductive surface is powered in both heating and cooling modes: using electric resistance for heating like the first prototype, and adding small blower fans to increase the convection on the underside of the metal panel during the overheated period. These two blowers, each of which requires approximately 1 watt, help evacuate heat from the conductive surface and induce air movement around the pelvic area by releasing the air out of openings aimed at the user's lower trunk and lap area to provide additional cooling. These details of the underside are shown in figure 4.3c. This prototype also address the concerns that the direct contact with the conductive surface—while effective at removing heat—leads to a discomfort sensation by being too conductive. Furthermore, aluminum provides a poor surface for writing and other office tasks, and may represent aesthetic challenges. Covering the plate addresses these issues, but would reduce the effectiveness of conductive heat transfer, requiring careful analysis and design. In this prototype, the metal plate was mounted flush to a substrate, and the entire surface covered with a continuous thin laminate top. This makes the system invisible except from the underside, and provides a thin layer protecting people from direct contact with the plate. It also provides a great deal of aesthetic flexibility as designers can choose from a wide array of laminate surfaces, and provides a familiar (indeed typical) surface for the workstation.



(a) *Prototype desk with exposed conductive surface for cooling, and resistance heating.* (b) *Prototype desk with reversible conductive surface for passive cooling.* (c) *Underside of the desk showing the conductive surface and blower fans.*

Figure 4.3: *Photographs of the conductive surfaces on prototype desks.*

Using the prototypes we gathered a range of anecdotal information about the comfort

or discomfort of the conductive surface, the efficacy of the reversible plate, the benefit of the additional conduction area and other factors.

To supplement this design feedback with a quantitative comparison, we also conducted two-dimensional heat transfer analysis. Using THERM, a 2D finite element analysis software package developed by Lawrence Berkeley National Lab, we modeled a transverse section of several possible desk designs, each with two “wrists” resting on the surface. The wrists were modeled as having skin temperature of  $33.0^{\circ}\text{C}$  ( $91.4^{\circ}\text{F}$ ), while the ambient air, and therefore the materials in the desk, were modeled at a temperature of  $28.0^{\circ}\text{C}$  [ $82.0^{\circ}\text{F}$ ] to represent a slightly overheated space in which the conduction would offer a desirable contribution to thermal comfort. The simulation modeled the heat flow from the wrists into the desk surface, as well as through the desk surface to the ambient air conditions. The results are visible in the false-color images in figure 4.4.

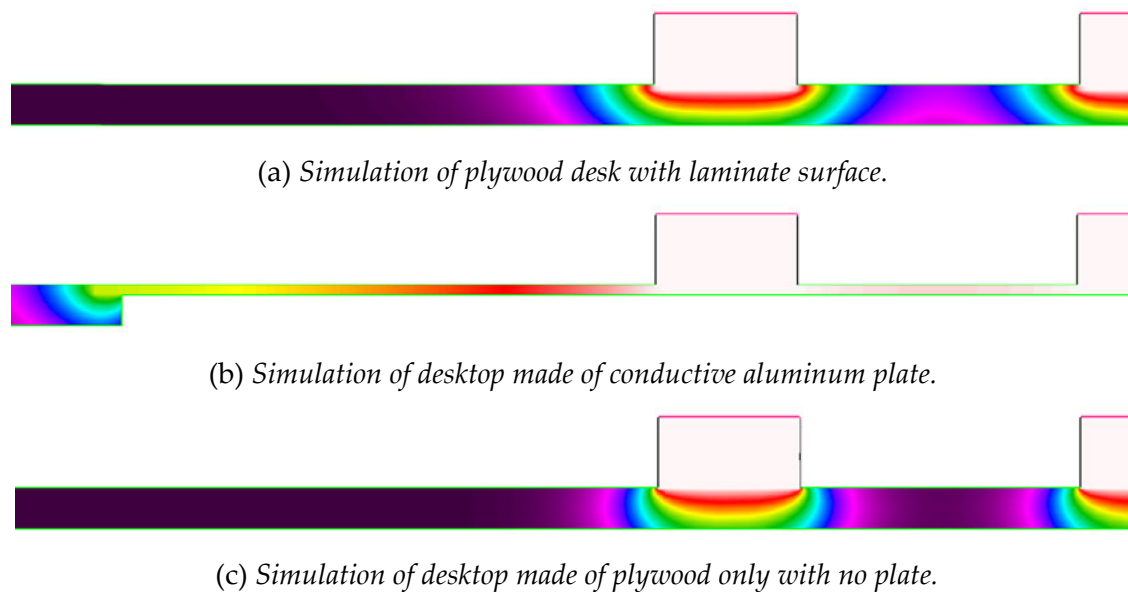

Figure 4.4: Two-dimensional heat transfer analysis for wrists placed on various conductive surfaces.

The quantitative results are presented in table 4.1 with the resulting heat transfer coefficients across those interfaces. Using some reasonable estimates of contact areas associated with the wrists and hands, and the same  $5^{\circ}\text{C}$  [ $9^{\circ}\text{F}$ ] temperature difference, it is possible to estimate the total heat energy lost through each of these systems. These data could also serve as input for simulations of whole body sensation and satisfaction; for example using the Advanced Human Thermal Comfort Model, a computer tool developed to predict human sensation and comfort in complex thermal environments (Huizenga, Zhang, and Arens, 2001).



Condition	Surface	Substrate	$T_{sk}$ °C	$T_a$ °C	$\Delta T$ K	$L_{boundary}$ m	$Q_{boundary}$ $\frac{W}{m^2K}$
Control	Laminate	Plywood	33.0	28.0	5.0	0.1016	18.82
Exposed Plate	Aluminum	none	33.0	28.0	5.0	0.1016	54.80
Reversible	Plywood	none	33.0	28.0	5.0	0.1016	11.95
Laminated	Laminate	Aluminum	33.0	28.0	5.0	0.1016	64.90

Table 4.1: Conditions and results for 2D heat transfer simulations for various conductive surfaces.

# Chapter 5

## Combined CBE Personal Comfort System

### 5.1 System Background, Problem, and Objective

The purpose of field testing Personal Comfort Systems is to remove barriers to adoption, specifically by testing the hypothesis that PCS could provide increased comfort and reduced energy consumption. To do so requires comparing building energy consumption and occupant satisfaction for office workers using local low-energy thermal controls with those using only conventional conditioning. That comparison demands certain kinds of data: we need to know the thermal conditions in which the system (and people) are operating. We need to know if the person is comfortable, which demands a “right-now” survey of sensation and satisfaction. We need to know if the person is at their desk or not; if they are, we need to know if they are using the personal control system, and if so how much. To address the energy side, we need to know if and how much energy each of the Personal Comfort System components are using, and how much the building is using, and how much it would be using if the systems were not in place. Thus a personal comfort system must not only integrate local heating and cooling devices like the fan and foot-warmer into a practical solution, it must also support the collection and communication of data to support this inquiry.

### 5.2 System design

The final system design is shown in figure 5.1, and included an under-desk footwarmer, fabricated out of sheet steel, and a desktop fan, fabricated from injection molded plastic with a flexible gooseneck. The footwarmer uses reflector lamps to warm the top of the subjects feet through radiation and a UL-listed dimmer to control their level. The fan uses a modified computer fan inside a custom cowling to provide quiet, directional airflow as desired by the user.

The fan base houses the controls, signals and intelligence for the entire system, built

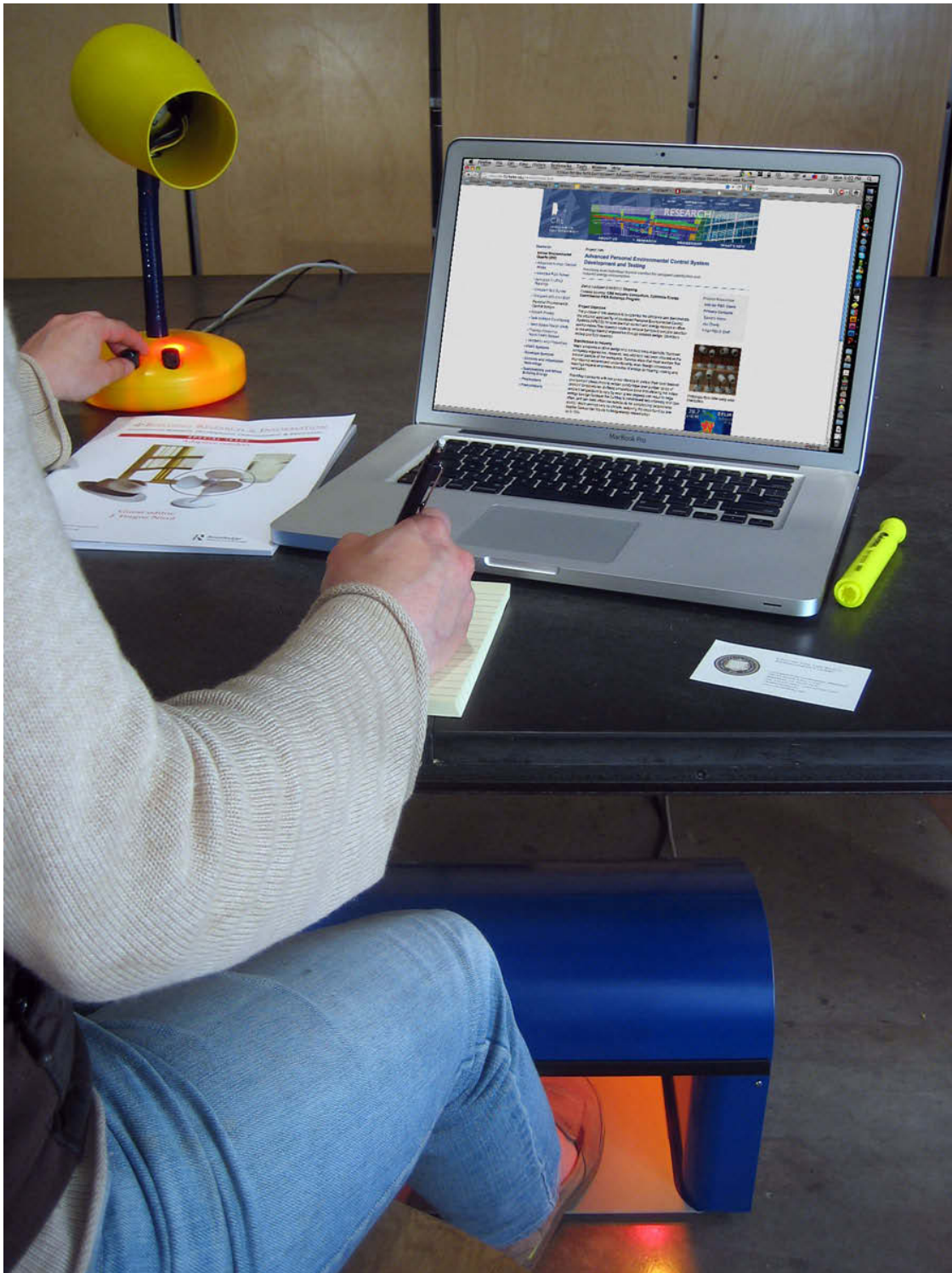

Figure 5.1: Photograph illustrating the component parts and connections for the CBE Personal Comfort System in use.

around an Arduino Duemilanove micro-controller with an AT128 processor, which is illustrated in a circuit diagram in figure 2.20. The device connects to the subject's computer using USB for data reporting. A six-pin mini-DIN cable connects the footwarmer to the micro-controller to record occupancy and control operation. Feedback to the user about PCM operation comes via two dimming, colored LEDs on the base. The LEDs are dimmed using PWM, which tends to cause slight stepping at low levels. User input and control is through two rotating potentiometers indicating state to the Arduino, which then adjusts the settings accordingly.

Use of a micro-controller was originally a cost decision, as the Arduino would cost about the same or less than prototyping and having a custom chip fabricated. The team also judged it to be faster to develop (likely true) and above all, very forgiving of mistakes (certainly true). A great feature of the Arduino is flexibility. Neither the inputs (knobs) nor outputs (fan speed settings, footwarmer setting) nor feedback (LEDs) are directly controlled or hardwired. Everything is a signal into or out of the Arduino, and therefore everything is subject to programming, which is incredibly powerful.

The Arduino has a buffer to store data directly on the chip should the connection to the PC be lost. Although the Arduino has 1,024 bytes of Electrically Erasable Programmable Read-Only Memory (EEPROM) memory available, the first 28 are used for various software functions, such as recording the personal comfort system's identification number, calibration constants and time signatures. The remaining 995 bytes are available as an on-board buffer. Since each record of temperature and personal comfort system use-state requires three bytes, this translates into 331 records, which at a one minute sample interval provides 5.5 hours of buffer. Increasing the interval to five minutes provides over a day of buffer space without the need for a PC connection.

EEPROM is a nonvolatile storage, meaning it remains even when power is removed, and is therefore perfect for small amounts of onboard storage needed on the PCM. However, EEPROM on the Arduino is only guaranteed for 100,000 read-write cycles<sup>1</sup>. To preserve memory integrity, the software avoids reading and writing the same early bytes over and over by remembering where data was last written and then continuing from that point. Protecting the integrity of the memory also prompted a decision not to include an on-board clock or timer, but to simply record the last contact time with the PC, and develop the time stamp for data by incrementally adding the sampling interval to that contact time. The system is much more than the local parts at the workstation; the fan, footwarmer, connections, and controls. The PC connection allows the personal comfort system to become a node in a wider database connected to the internet, which it uses to transmit the study data back to the central database at UC Berkeley. The PC client software also has a buffer on the local hard-drive, should the connection to the database via the internet be lost. This connection expands the possibilities for the study by collecting

---

<sup>1</sup>A commercial version of the device should add dedicated, longer-life memory to buffer or even log the data

the data from numerous and far-flung field sites in near-real time and delivering it directly to the researchers. This presents some technical and security challenges which are described in subsequent sections.

## 5.3 Fabrication

### 5.3.1 Production

Unlike testing in a controlled environmental chamber with perhaps a handful of prototypes, any field test would require a large number of personal comfort systems. This turned out to be among the more interesting challenges. To begin we assembled a few PCS, and timed the process, finding that some steps were quite intricate and complicated, in particular the solder-intensive work with the mini-DIN connectors that allow the arduino to communicate with the footwarmer. The sort of bespoke hand-work associated with having a single individual assemble each part in sequence worked fine for a handful of prototypes, but to produce one hundred would require a different approach. We quickly realized that we needed to mass produce sub-component assemblies like the solder work before assembling completed devices.

We set up a workspace to use. Fortunately, CBE has access to excellent high-bay space, in which the team constructed a pair of work benches, one dedicated to the footwarmers (which are high-voltage devices) and the other to the fans (which are all low-voltage, direct current devices). The separation was partially just to keep parts organized, partially reflected the different kind of work to be done, and partially for the safety of keeping low-voltage parts out of high-voltage assemblies. It also made work faster and more efficient to have the tools and components ready to hand, as shown in figure 5.2.

For assembly, several tables could be set up in the middle of the space for specialized tasks, such as prepping a fan, or inserting modules. This space is shown in figure 5.3. We designed a circular workflow that minimized crossing paths to go from parts to sub-assemblies to final assembly, testing, packaging and storage. Simple, step-by-step (and often graphic) directions at each workstation explained the tasks to be completed and how to test and troubleshoot possible problems.

### 5.3.2 Calibration

To evaluate the quality of the temperature sensors and validate a method to calibrate them, a sample of thirteen fans was selected at random from our production run for temperature sensor calibration. First, we needed to gather data in set conditions and record how the measurements varied. Each fan was loaded with a special version of the software that increased the temperature sampling rate to every 15 seconds, and set the fan sensor timeout





Figure 5.2: Bench for assembling the fan, note the arrangement of tools and materials ready to hand, and the laptop for programming and testing the microcontroller.



Figure 5.3: Note the work benches along the back and right edge for assembling sub components of the footwarmer and fan respectively, and the tables in the center for final assembly. The prototype systems are along the left and were also used to test and package components.



to 7200 seconds (2 hours) so it would not turn off during the test. The fans were placed inside the UC Berkeley controlled environmental chamber which was set to maintain 19°C. Three large oscillating fans (not part of the test group) were placed in the chamber to ensure the room air was well-mixed. The chamber was allowed to condition for a minimum of three hours to come to equilibrium before the fans were introduced.



Figure 5.4: A random sample of fans arranged for calibration in the controlled environmental chamber. Note the mercury reference thermometer on its stand..

The CBE fans had not operated for at least four hours prior to being placed in the chamber, to ensure they were not hot. The times and temperature data for a representative calibration run are provided in table 5.1. After the chamber came to temperature, the sample of fans for calibration were arranged in a line on a table 30 inches above the finished floor, all pointing to the same wall so they enjoyed similar radiant view factors as shown in figure 5.4. The researchers then left the room, and the fans were allowed to condition inside the chamber undisturbed for 20 minutes, and then began a five minute sample period totaling twenty individual measurements. At the end of this sample, the researcher entered the chamber, turned all the fans to their highest speed operation and left. Again, the fans were allowed to stabilize with nobody entering the chamber for 20

minutes, before a five minute, twenty-sample data set was collected. The data samples were recored on the EEPROM of the internal micro-controller of each fan, along with a time-stamp, and then downloaded after both sample periods had been collected.

Time	Event	Unix Time	Reference (°F)	Reference (°C)
16:17	Last person out		67.60	19.78
16:55	Begin "off" test period	1316562903		
17:00	End off test	1316563248		
17:01	Enter room, read temps, fans on		67.60	19.78
17:24	Begin "on" test	1316564642		
17:27	End "on" test	1316564867		
17:28	Enter room, read temps.		67.80	19.89

Table 5.1: *Times and temperatures for the temperature sensor calibration.*

The chamber temperature was constantly recorded using a sensor located in the HVAC equipment. The calibration temperature was read from a mercury thermometer before the start of each period. The thermometer was located on a stand, with the sensor placed inside a fan that did not operate, so it would have a similar view factor, as shown in figure 5.4. This temperature taken inside the chamber was used as the reference temperature for analysis.

Figure 5.5 shows the results of one test as box and whisker plots showing how the temperatures recorded by each of the fans varies relative to the reference temperature. The data indicate that the system's sensors are generally reporting temperatures nearly 2°C cooler than the reference thermometer is measuring. They also indicate a greater range of temperature variation when the fans are on than off. This was troubling as it suggested some form of internal interference or field effect associated with fan operation. We later repeated these tests at different set-points to check for temperature dependency.

As a result of this testing, we determined that the temperature sensors should be calibrated based on both temperature and fan speed, most likely as a result of the electromagnetic field produced by the motor. We resolved to correct this for each fan in on-board software, so that correct results would be reported to the server, and no additional data processing would be required by those using the data. This was implemented in the fan software using the a simple slope-intercept calibration formula 5.1.

$$T_{calibrated} = (a \times T_{averaged}) + (b \times FanSpeed) + c \quad (5.1)$$

Where a, b, and c are all constants calculated for the specific fan based on tests in the controlled environmental chamber. For the tests, fans were evaluated in batches at two speeds in each of two temperatures. The resulting data was compared with references to generate the calibration constants, which were then programed into the EEPROM of

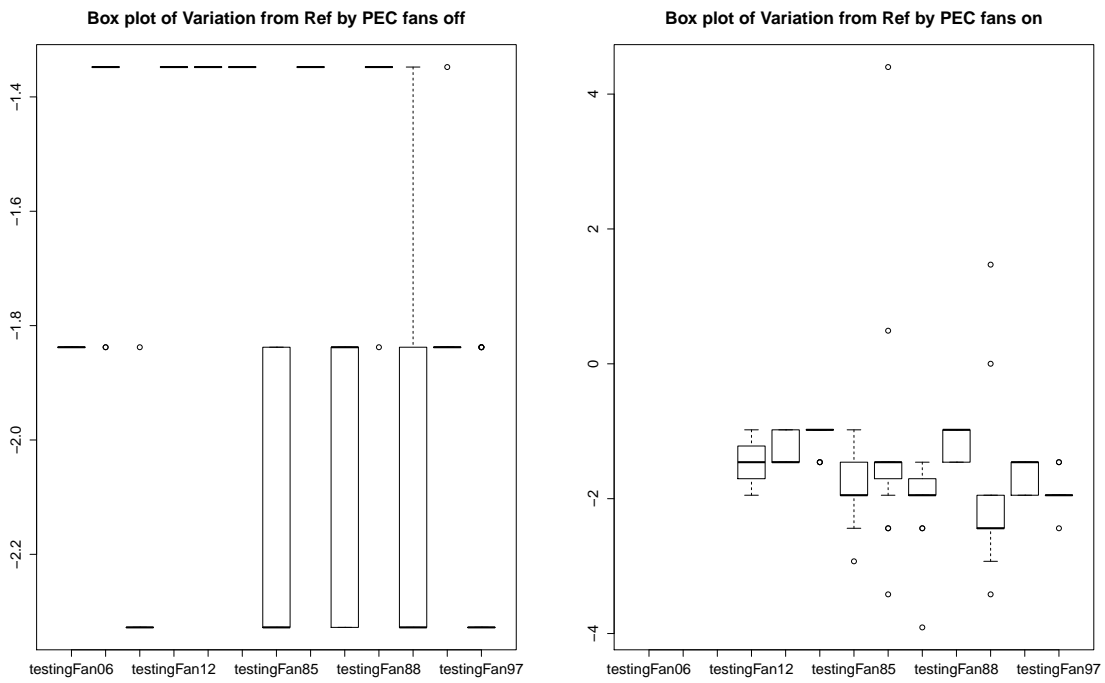

(a) Variance from reference with fans off.

(b) Variance from reference with fans on.

Figure 5.5: Results of fan calibration by fan serial number for thirteen fans at two speeds in 68°F conditions, note greater variance when fans are on than off.

each fan as a constant. This formula only uses two speeds (off and 100%) to simplify the calibration across multiple speeds. The fan software compensates for this simplification when taking temperature by briefly turning the fan off if the speed is less than 50%, or turning it up to the top speed if it is greater than 50% before recording the temperature data. These changes in speed are short-duration and are essentially imperceptible to the user but result in more accurate temperature measurements.

## 5.4 Field Study Methods

The final part of this investigation developed the methods to test a Personal Comfort System, and this conditioning strategy by deploying instrumented personal control devices in the field and using the internet to collect the data and administer studies. While potentially quite powerful, these mixed-methods, and the distributed-networked model bring some challenges for data management and the protection of human subjects. This chapter outlines a study method designed to address these concerns using the personal control devices developed at the Center for the Built Environment.

In addition to establishing the structure for CBE's continued use of these prototype Personal Comfort Systems, other researchers working in personal control, or human thermal comfort may find this description useful insofar as it identifies some of the challenges inherent to the work, and offers one possible approach to addressing them. Finally, a wider audience of those interested in the distributed-networked research model, and all who seek to know more by measuring the world and asking people about it should find these obstacles familiar, and perhaps the solutions helpful.

### 5.4.1 Objective

Because the personal comfort system being tested would be placed in the environments we sought to measure, it seemed obvious to equip them with sensors to gather some or all of the data that is needed. In the same way that the Personal Comfort Systems as conditioning devices represent a shift from a single, powerful centralized system for HVAC, the PCS as research devices represent a shift from highly sophisticated research instruments to a distributed network of sensing and data collection. Included in that shift is the notion of continuous, rather than episodic data collection.

While field data can be collected lots of ways, we chose to piggyback our data communication on an existing, essentially ubiquitous and easy-adaptable infrastructure platform, the internet. This had practical and pragmatic advantages of course. Study sites can be physically located anywhere with an internet connection, making testing in various types of offices and climates easy and inexpensive. The implication for the design of research methods is that, with no need for economies of scale, studying numerous, geographically-dispersed locations is no more difficult than a few large ones. Furthermore, with the data

on a secure server, the researchers too need not be in the same place or even one single place, opening up new opportunities for collaboration. Beyond mere convenience, however, networked data points offer fundamentally new research opportunities, for example real-time surveys that respond to user behavior or double-blind intervention studies, both described in section [6.2](#).

### 5.4.2 High Throughput Research

This study also marks a movement to what are sometimes known as “high-throughput” research methods. Widely used in drug discovery and computer science, the approach is now increasingly used in social sciences like economics and archeology. The notion is that rather than a deep look at a small number of cases, we provide a relatively shallow look at a very large number of cases. The insights come from identifying trends across that wide set. Rather than a detailed picture of the thermal environment and occupant sensation and perceptions as we might achieve with a laboratory study, this study seeks a relatively shallow understanding across a large number of individuals. These data can be helpful to identify areas for further, more in-depth investigation. They can also be used to test theories, either through interventions, or by reviewing existing data. Given a sufficiently large and representative sample, the results can be extrapolated to the whole population. This is in some ways connected to the notion of “big data” in that given the low cost of sensors and computer storage, we could now have sampling intervals so rapid as to be virtually continuous. This adds up quite quickly: a full deployment of 100 prototype personal comfort system units—recording the time, temperature, occupancy, and user settings at one-minute intervals—would generate about a million records each week, not including the right-now survey data. This represents a few challenges for data transmission, data storage, data analysis, and of course, data security.

### 5.4.3 Procedure

This section outlines the study design as background to the challenges and resulting technical solutions incorporated in the research method. Those details will be expanded in the parts [5.4.4](#) and [5.4.5](#).

#### Recruiting and site selection

Because the initial experimental design was for a pilot study, it did not require a specific sample size or constituency for statistical testing, and so recruiting of test subjects could be somewhat flexible. As a result, there was no need for prescreening, or other efforts to establish a particular sample. For the pilot test, the team recruited subjects by inviting members of the Center for the Built Environment, an industry-academic research partnership, to volunteer as study sites. These partners informed their employees about

the opportunity to test the personal thermal control devices in their office. In a perhaps telling anecdote about the state of human thermal comfort in American office buildings, there was no shortage of volunteers. None of the CBE partners, nor their employees who volunteered to participate in this study, had any financial or intellectual property stake in the devices being tested, so their willingness was solely to help advance our understanding of thermal ergonomics, and perhaps improve their own comfort in their workplaces. While this situation naturally introduces the possibility of selection bias—since perhaps only those dissatisfied with their environment will volunteer to participate—given the type of information we hoped to gather, the selection bias was not considered a confounding feature. Indeed, addressing the comfort needs of those least satisfied would most directly address the ability of the devices to provide comfort across a range of conditions.

### **IT Guide**

Because the personal control devices rely on the local network and internet connection, we developed an Information Technology guide that describes the functioning of each element of hardware and software. This document is included as appendix E. We provided this document to the management and IT staff at locations interested in becoming study sites to be sure the Personal Comfort System would operate smoothly and not interfere with normal operation of those systems.

### **Informed consent**

To comply with human subjects protocols, each study site submitted a letter stating their understanding of the study requirements, and promising their cooperation. Cooperation included placing the physical devices in their office, installing the software on their computers and adding a small amount of network traffic to send the data back to the CBE server. The study sites also agreed to allow the study to take place during work hours and promised not to exert undue influence on employees regarding their participation, for example by providing or denying benefits to any employee based on their decision to participate.

Subjects at each location self-selected by volunteering to participate in the study if they so desired. Once the local management and/or building managers in each office informed all the occupants of their space about the upcoming research project they did not affect the participation or non-participation of any person in this study, and the research team provided the consent form and description of the project (contained in appendix B) to potential subjects who express interest in participating. As detailed in the informed consent document, participation was completely voluntary and there were no consequences for those who chose not participate, nor compensation for those who did. The research team collected completed forms on paper at the study site before installing the personal comfort system at subjects' workstations, as described below.



### Site visit and installation procedure



Figure 5.6: *The research team installing personal control devices at a study site*

Once five to ten individuals (one car-load of PCS devices) at a given physical research site expressed interest in becoming subjects, the research team coordinated with the potential subjects, IT staff, and local management to visit that site to begin the research at that location. Naturally, the first step of each site visit was collecting signed Informed Consent Forms, and answering any questions or concerns regarding the research. As always, anyone who did not wish to participate could withdraw at any time. During each site visit, the research team installed a personal comfort system (fan and footwarmer) at each subject's workstation and ensured it was working correctly. The team also installed the desktop client software on the subject's computer and confirmed it could connect to the database server to transfer the research data. Finally, the team demonstrated the safe and effective use of the system to each subject and answered any questions. These brief conversations not only helped the user off to a good start but provided an opportunity to collect informal, but often illuminating feedback, for example the visual feedback of figure 5.7.





*Figure 5.7: A new PCS user providing immediate feedback to the research team. Note in particular the bare feet and sweater on chair back.*

To provide longer term support, each subject was provided a half-page information reference card, describing the safe set-up, operation and basic troubleshooting for their personal control devices. The card, shown in figure 5.8, was designed as a simple, primarily graphic instruction for the user, with no special knowledge about how the system worked. While the research team initially set-up the devices at each site in the pilot test, providing the set-up instructions gave flexibility so the devices could be moved to new workstations within that site, and provided resilience if there were problems or a new computer.

The card also allowed the possibility of a research design in which the personal comfort systems are shipped to sites without requiring a member of the research team to travel to those locations. The flexibility to ship rather than travel reduces cost and extends the possible range of sites in the research, one of the objectives of the distributed-networked model tested in this pilot study. Recognizing that questions inevitably arise even with the best user documentation, the information card also pointed to the project specific website with additional information and ongoing updates. Finally, the card, the website and the serial number on the bottom of each fan and footwarmer all included an email address specially set up for the project: [littlefans@cbe.berkeley.edu](mailto:littlefans@cbe.berkeley.edu) to contact the team with questions or concerns. The dedicated email was configured to forward to a specific team member, to simplify organization and avoid succession problems should the staffing change in the middle of a research project.

For administrative purposes, the research team noted the serial number of the system issued to each subject, and gathered each subject's contact information using a "Research Subject Information Sheet" at the beginning of the study (see appendix C). The team collected this personal data only to contact research subjects, troubleshoot any problems with the Personal Comfort System Devices, and ensure the return of the System at the end of the study—generally the most difficult of the three uses!

A ongoing effort in thermal comfort research seeks to understand the affect of age, sex and body mass index (BMI) on thermal sensation and thermal comfort (e.g. Kim et al., 2013; Zhai et al., 2014). Collecting this sort of demographic data about our subjects supports and benefits from this work by making the entire Personal Comfort dataset richer, and enabling more nuanced findings. From a research methods standpoint, asking these demographic questions also establishes a system which can collect information about a particular subject and connect it to the measurement and usage data from that person's system without revealing the subjects' identity. Building in this system, and testing it, offers flexibility to include future research questions as yet unknown. While important for the study, age, sex, height and weight are sensitive information, and in some contexts might be considered personally-identifiable information, so collecting and storing them required particular care. This lead to an overall approach that involved sorting data by type, and thereby separating personal data from demographic data for security, as described in section 5.4.5 and illustrated in figure 5.9 on page 88.

## USER GUIDE

### PERSONAL ENVIRONMENTAL CONTROL SYSTEM

Thank you for testing the UC Berkeley CBE Personal Environmental Control System in your workspace! This information card will help you set up and use the PECS. We hope using this low-energy system increases your thermal comfort and satisfaction.

For additional information, software, and documents please visit: [www.cbe.berkeley.edu/pecs](http://www.cbe.berkeley.edu/pecs)

For questions or comments please contact us at: [littleFans@cbe.berkeley.edu](mailto:littleFans@cbe.berkeley.edu)



## SETTING UP

### 1 POSITION COMPONENTS

Arrange the fan and foot-warmer comfortably in your workspace; be sure they sit on flat, stable surfaces.

The fan works best pointed at your head from a few feet away and to the side. The fan neck is flexible to adjust aim.

Place the footwarmer under the desk, where you normally place your feet. If find your shins touch uncomfortably, push the footwarmer back.

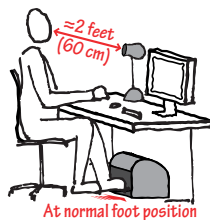

### 2 CONNECT CABLES

Your PECS uses four cables which should be connected in the following order:

1 Built-in Footwarmer plug to 110V wall outlet



2 6-pin mini-DIN cable from Footwarmer to Fan

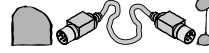

3 12V DC-adaptor from Fan to 110V wall outlet



4 USB Cable from Fan to your personal computer



### 3 INSTALL SOFTWARE

Download the software to connects your computer to your PECS from:

<http://www.cbe.berkeley.edu/research/pec-links.htm>

When the download is finished, double click the file to install the software.

The software is designed to launch automatically when your computer starts and run in the background. You can minimize the console window if it opens, as no input or action is required from you.

The software uses about 5 MB of memory and much less than 1% of your computer's processor power.

## CONTROLS

Both the fan and footwarmer are controlled from the fan base

- COWLING AND FAN**
- FAN VACANCY SENSOR**  
The fan enters sleep mode if it has not "seen" motion in front of it for a few minutes. Slowly pulsing lights indicate sleep.
- FLEXIBLE GOOSENECK**  
Tilt the neck using one hand on the base and the other on the cowling to aim airstream as desired.
- FOOTWARMER HEAT KNOB**  
Turn clockwise to increase temperature, setting is indicated by red light.
- FAN SPEED KNOB**  
Turn clockwise to increase air speed, indicated by blue light.

## TROUBLESHOOTING

**My fan and/or footwarmer does not turn on when I adjust the knobs, and there are no lights on the base of the fan:**  
Check to make sure all of the cables are correctly connected. Unplug all the cables and confirm that the wall outlets or power strip are working. Reconnect the PEC cables in the order listed in step two on the reverse of this card.

**My fan and/or footwarmer keeps turning off unexpectedly and the lights pulse slowly:**  
The PECS is entering sleep mode, which saves energy by turning off the devices after a few minutes delay. The fan uses a motion sensor inside the white plastic dome in the middle of the fan to detect vacancy. If the fan is not pointing towards you, or if you are very still, it may shut off, to avoid this, adjust the fan so that it will "see" motion. The footwarmer sensor is connected to the footplate. When using the footwarmer; be sure your feet are far enough inside to press the plate down. Please contact us if the system goes to sleep too quickly.

**My fan and/or footwarmer is stuck on and is not responding to the knobs, or the indicator lights do not seem to work:**  
Rarely (e.g. after a power failure) the computer inside the PECS gets stuck and will not respond to user input. To reset, simply disconnect the fan from the USB and the wall outlet, wait ten seconds and reconnect. If problems persist, please contact CBE at the address below.

**I have other questions, concerns, feedback, or comments:**  
Please contact us at: [littleFans@cbe.berkeley.edu](mailto:littleFans@cbe.berkeley.edu)

Figure 5.8: The front and back of the information reference card provided to each user outlining the set-up, operation and troubleshooting of their personal comfort system.

## Data Collection

As a connected device, the Personal Comfort System can begin reporting data as immediately after being installed at a workstation, so the study period for each subject theoretically begins as soon as the research team leaves. Naturally the team can elect to ignore data samples from any portion of the study period, for example to leave out the first few hours and days of experimentation. Alternatively, this might provide a useful insight into the adoption of new technology, particularly in contrast with data from later in the study when the device is well established. Subjects use the Personal Comfort System as they wish for the duration of the study period, responding to occasional web surveys about thermal comfort while the Personal Comfort System records various measurements on a preset interval.

To preserve the privacy and anonymity of the research subjects, their survey responses, and the measurements taken by the personal control device are depersonalized, meaning they are identified only with a random *peCID* number, rather than some personally identifiable information like a name. Both the web-based survey data and the measured data are transmitted and stored securely, see section 5.4.5 and figure 5.9 for additional details.

Throughout the study period, each subject enjoys complete, individual control over the Personal Comfort System; subjects can choose to use the system or not, and set it however they wish at any time. At pseudo-random intervals the desktop client prompts the subject to take a short online survey by following a link to a secure website. The intervals between surveys are never less than two days (to avoid nuisance) nor more than 14 days, and users may ignore any or all of the survey prompts. At fixed intervals (typically once every minute or every five minutes) the micro-controller in the Personal Comfort System records a series of measurements. These measurements are: ambient air temperature, fan speed setting, footwarmer intensity setting, fan occupancy sensor state, footwarmer occupancy sensor state, and whether the system is asleep or active. This data is passed to the desktop client over a USB cable, and buffered briefly and then securely transmitted over the internet to the research database at CBE.

## Study Closeout

At the end of the study period, the research team returns to each research site to collect the systems from subjects. They also un-install the desktop client software from each subject's computer. At the close of the study, the research team destroys the administrative records of personal information (e.g. name, address) collected about each subject. Records of individual subjects who wish to end their participation in the study early are deleted from the file at the time of their withdrawal.

To compile the final research dataset, the team connects the demographic data (e.g. age, sex) to the non-identified measured (e.g. Temperature, occupancy) and survey (e.g. thermal sensation and comfort) data in the database, and then re-keys this data to prevent

any possible connection to a specific subject or system. The result, a data-rich, completely anonymous, fine-resolution data set is used for analysis and may be safely shared with other researchers and stored in a non-secure environment.

Finally, the unique pecID embedded inside each personal comfort system, which connects a specific device (keyed by printed serial number) to an individual subject's data (keyed by pecID), is reset to a new unique but random string, so that the device can be issued to a new user.

#### 5.4.4 Human Subjects Protections

Developing a study method that could gather the breadth and richness of available data, while simultaneously protecting the safety, welfare and privacy of the subjects called for a unique design. Because the study design integrates a number of methods and data sources, it can be difficult to classify in conventional human subjects research protocols. For example, it is not a pure survey<sup>2</sup> because it also includes measuring temperature and recording the use and occupancy with the Personal Comfort System in the office environment. Similarly, the data is not purely anonymous, because we needed to collect some personally identifiable demographic data, such as age and weight for the research, and gather directory information in order to administer the study and ensure the return of our research prototypes. The UC Berkeley Committee for Protection of Human Subjects offers an expedited review for "Research on individual or group characteristics or behavior," which describes the objectives of this study, and was referenced as part of our submission for approval.

Fortunately, the research presented extremely low risks to participants' physical safety or comfort (indeed that was the condition we were seeking to improve!) The Personal Comfort Systems used in this study employ directed radiant heat from electric lamps and low-velocity air movement from fans to heat and cool people; these methods are commonly and safely used in buildings around the world. Furthermore, the Personal Comfort Systems used in this study are entirely under the control of individual study participants, who can adjust or discontinue the use of the system at any time. Therefore, there are no known physical risks or discomforts associated with the study procedures.

After addressing safety and discomfort, we turned to the small possibility that confidential study data could be compromised. While this is a risk for any study, we took great care to minimize both the likelihood and consequences of such a breach. The first step was to carefully consider all the data we planned to collect: from sensors, through right-now surveys and during the initial enrollment in the study. By not collecting any more data than the research demanded, we minimize the consequences of any possible

---

<sup>2</sup>Federal Regulations governing human subject protections allow institutions to exempt specific study designs from full review by their Institutional Review Board in favor of an expedited review. To do so, the research design must present no more than minimal risk to the subjects, and must use only specific research procedures, for example, surveys.



breach. Furthermore, the bulk of the research data collected consists of measurements and survey responses that do not contain personal identifiers, so that data cannot be connected to specific subjects. While this data will be secured, its release should not harm subjects. The personal and demographic data collected at the start of the study (see appendices C and D) could potentially be personally identifiable, so additional protections were put in place for these data. The demographic and contact information was collected on these paper forms at the start of the study, so it was fairly straightforward to secure. On the other hand, the computerized data, transmitted via the network required some additional complexity, which will be detailed in part 5.4.5.

In addition to the risks, we of course articulated the possible benefits for study participants, in part to ensure they did not have undue pressure or compulsion to participate. Obviously for the study, subjects would be provided with a Personal Comfort System to use for the duration of the study. Since many office workers find their workspace thermally uncomfortable, the use of the system could (hopefully!) result in an individual benefit of increased thermal comfort and satisfaction. That said, the fact that people do work in their current space suggests that the mere possibility of increased comfort offered by participating in this study is not an undue influence to do so. The societal benefit of this study is that Personal Comfort Systems will be better understood and possibly more widely adopted, increasing human thermal comfort and reducing energy use in buildings.

### 5.4.5 Data Management

As mentioned previously, data management is, in large part, the crux of the human-subjects issue for this study. Given that there are no known physical risks or discomforts associated with this research, the main concern is safeguarding the various kinds of data streaming in. Strictly speaking, the data cannot be collected anonymously, however, personal data is collected, processed and stored separately from non-identity data for the duration of the study.

Although the possible harm associated with a release of personal data in this study is thankfully small, the research team took subject privacy seriously, and therefore included high levels of administrative, physical and technical safeguards to protect the research data. This protocol is designed to limit the information collected; to separate personal information from the data needed for the research investigation; to collect, transmit, and store research data securely; and responsibly limit access to subject information and study data. The data collection, transmission, storage and security arrangements are illustrated in figure 5.9. The diagram begins with the research subject (at the top center), moves through each of the project phases (numerals in the left margin) and then concludes with the final research data-set (at the bottom center). Personally-identifiable data, consisting of “Personal” and “Demographic” data, are described on the left-hand side while the non-identity data, including the “Measured” and “Survey” data are on the right. The following



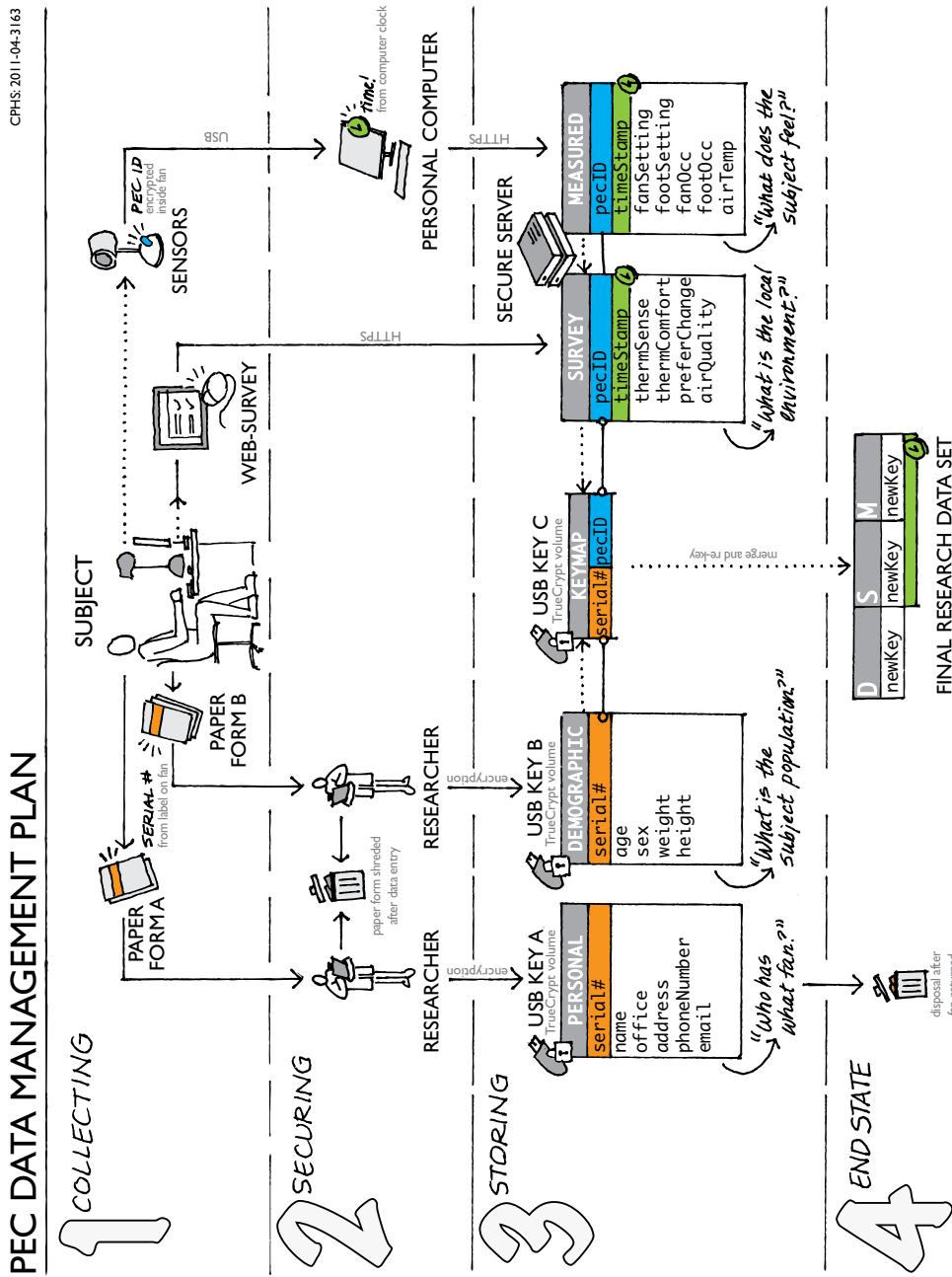

Figure 5.9: Diagram illustrating the phases of the project, the various types of data, and how each data type is collected, transmitted, secured and stored.

subsections of the text detail the elements of this outline and the technical methods used to achieve them.

### Separation of data

To preserve privacy this protocol—like many others—divides the research data into two sets: identity and non-identity. The first set consists of demographic information about each subject, and contact information necessary for the administration of the research. The second contains the measured and survey data that constitute the research investigation. This protocol protects subject confidentiality by making the links between the identity and non-identity data scarce, secure and short-lived.

A conventional way to protect the anonymity of data is to “code” it using a randomly-assigned alpha numeric sequence, such that the only data shared by the sets is the random code. The result is a Venn diagram in which each item in the list of personal information (i.e. each name) is associated with a code, and then the research data is also associated with the code. In some studies, the division of data is affected after collection of a single, combined dataset, by removing all the personally identifiable information into another dataset and replacing it with a random number or identity code assigned by the researcher as key value (*Human Research Protection Program*). The result are two sets of data: a so-called “de-identified” dataset containing the code and the research data, and an “identity-only” dataset, containing the code and the personally-identifiable information. Obviously, and as illustrated in figure 5.10, these two sets have only the random code in common. While this separation protects the research data from casual inspection, it also means that the file (called a keyfile) that connects names and other personal data with the codes can be used to identify any data in the study. These limitations are common to all simple-overlap designs, and this approach suffers an additional problem related to the particular methods used for this study. To connect a particular subject with their associated data during the analysis, we would need to tag the measured and survey data produced by the personal comfort system before it was transmitted over the public internet. Because we collect the various types of data separately, it would be impossible to assign the correct common code value without constantly referring back and forth between sets, therefore undermining the very separation we sought to create. Furthermore, this approach would put the code from the keyfile “in the wild” and was judged too risky.

While such a division represents fairly good security, our protocol has three critical differences. First, the data does not need to be split after the fact; from the moment of collection, personal data is separate from measured and survey data. That is critical as our study operates over a long time, with new subjects joining and others potentially leaving the study, so the division must be in place from the beginning, rather than applied in post-processing of the data. Dividing the data limits access to those who “need to know,” streamlines the technical implementation, and limits negative consequences should one set be compromised. The second difference derives from the first in that we describe the

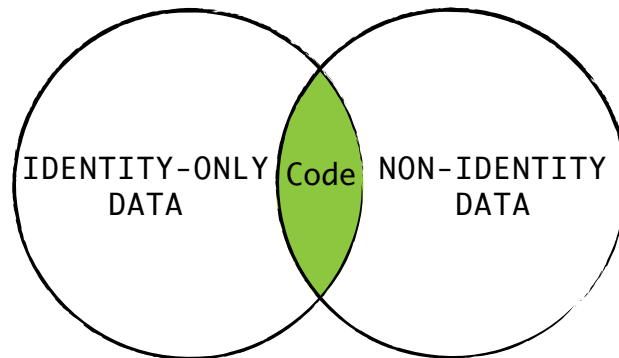

Figure 5.10: Conceptual diagram showing identity-only and non-identity (or in some cases, de-identified) datasets linked by a shared code value that appears in both sets.

bulk of the study data as “non-identity” rather than “de-identified” because it never contains personally identifiable data and we do not need to strip out personal identifiers. Third, to help preserve confidentiality, the identity-only and non-identity datasets have no data (such as the identity code in figure 5.10) in common. Instead, we decided to put a third link in the chain, such that the personal data and the measured data both overlap a third dataset, but do not overlap each other. In our case, that third dataset is a “keymap” which, as the name suggests, maps the unique codes used on the personal data (serial number) with the codes used on the measured and survey data (pecID). By making this third thing the only connection between the datasets, we need only secure that third thing to ensure the two sets cannot be connected to each other. This is illustrated in figure 5.11 and described below.

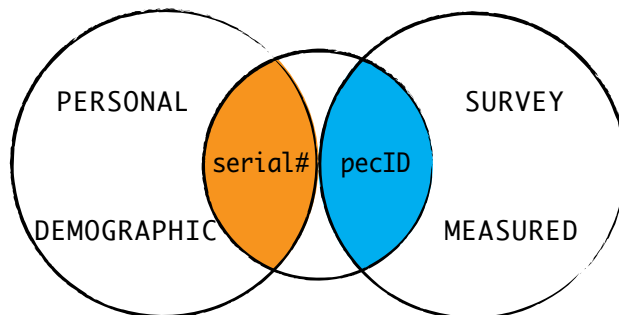

Figure 5.11: Conceptual diagram showing identity-only and non-identity datasets with no values in common. The unique keys in each file are connected only by a keyMap file which associates one pecID with one specific serial#.

For this study design, the personal data is collected and keyed using a serial number printed on the outside of the personal comfort system devices. This five-character alpha-numeric code is human readable, and supports the administration of the study.

The researcher can read the serial number off the unit at the time it is issued, and write that number on the contact information form (see appendix C) to associate a specific unit with a specific subject's contact information to administer the study and ensure the unit is returned at the end of the study. Meanwhile, the measured and survey data used for the research is keyed in the database using a secret pecID code programmed inside the devices. The pecID is a random, twelve-character alpha-numeric string stored in the encrypted Electrically Erasable Programmable Read Only Memory inside each system. We generated these twelve character strings using Haahr ([random.org](http://random.org)), a true random number generator that uses that atmospheric noise to produce randomness<sup>3</sup>. This pecID value is programmed by the research team before the units are issued to the field. It is erased when the system is returned, and a new value is programmed when the unit is issued to a new user.

These sets of data are collected and stored separately, and because they have no data (such as a researcher-assigned identity code) in common, there are only two connections between the identity-only administrative data and the non-identity study data. The primary connection is a mapping of both data sets' key-values inside the secure keyMap file mentioned above and illustrated in figure 5.11. This key map document consists of two columns of numbers, the first column contains the unique serial numbers printed on physical devices, the second column contains the unique pecID codes, random strings stored on the internal memory of the device. Because the identity data is keyed using the serial number of the personal comfort system issued to each subject and the non-identity study data is keyed using a the pecID value, the map makes it possible to connect any stream of study data to specific physical system (and by extension, to a subject) or vice-versa. A secondary link exists within an individual personal comfort system, inasmuch as the serial number is printed on the outside and the pecID code is encrypted on the EEPROM on the micro-controller inside. However, accessing the pecID inside the programming is a non-trivial task. While the data sets have no values in common and only scarce connections, these connections are vital to the success of the research. The data sets must be linked by this keyMap file for the duration of the study so the research team can trace problems in the measured data stream to a specific (possibly malfunctioning) personal comfort system. The link is also used at the conclusion of the study to associate demographic data with a specific stream measured and survey data. After that transfer, the links between identity-only and non-identity data are broken, permanently eliminating any connection between personal information and the rest of the study data. Section 5.4.5 explains the procedures for research data at the end of the study in more detail.

This keyMap structure, while sometimes cumbersome, means that securing the keymap

---

<sup>3</sup>We used a sixty-two character set (0-9, A-Z, and a-z), so with a twelve-character pecID string, there are  $62^{12} = 3.2 \times 10^{21}$  possible combinations, which WolframAlpha helpfully points out is roughly the number of grains of sand on earth. Twelve characters requires twelve bits (1.5 bytes) of memory in the PEC, but provides a sufficiently large set to ensure randomness, limit guessing, and prevent overlaps when new random pecID numbers must be generated for the next study subject.

file secures the separation of identity and non-identity data. Thus members of the research team can work on one, the other or both sets of data and never connect them unless they also have access to the file. The design of the study is that only the Principal Investigator and possibly the Student Investigator would access this file. The links between identity-only and non-identity data are secured by digitally and physically securing the `keyMap.csv` document and the EEPROM, as detailed in section 5.4.5.

### Types of Data

As previously stated, the most effective measure to minimize the risks associated with inadvertent release or malicious theft of the study data is to collect only the minimum data absolutely necessary for the study. Four types of research data were collected under this protocol: personal data for the administration of the study, demographic data to characterize the study population, measured data recording the patterns and conditions under which the personal comfort system is used and survey data indicating user perceptions of conditions and comfort. Of these four types, only the first two, personal and demographic data, contain personal identifiers and belong to the identity-data set, while the measured and survey data belong to the non-identity set. The purpose, contents and classification of each type of data are described below, and it may be helpful to refer to figure 5.9, which shows all these data types in step three. The identity-data set indicated is by orange bars on the left side of the figure, while the non-identity set is marked in blue on the right side.

### Personal

Personal (P) Data consists of the minimum identity information about each subject needed to conduct the study, and belongs to the identity data set. This data is collected using a paper “Contact Information” form (see appendix C) when the participant enrolls in the study, and includes each participant’s name, office address, phone number, email address and the serial number of the fan and footwarmer issued to them. The data is “keyed” using this serial number, a unique human-readable, five-digit alpha-numeric string that is printed on the bottom of the physical personal comfort system. The information sheets are brought back to campus and entered into a spreadsheet file, named `pecDistributionList.xls`, located on an encrypted USB flash drive. The data is transcribed shortly after it is collected, and once the data is transcribed from the sheet, the paper copies are destroyed. When not in use, the USB drive and any forms awaiting transcription are physically secured in a locked drawer. Only a handful of researchers have the password to access the encrypted USB drive.

## Demographic

Demographic (D) Data is used to characterize the population and categorize the research findings relative to other studies in the field and is treated as part of the identity data set. Demographic data is collected during the initial site visit using a paper “Personal Characteristics” form included as appendix D. These data consist of the sex, age, height and weight of the subject, and the serial number of the fan and footwarmer issued to them. The data is “keyed” using the serial number, a unique human-readable, five-digit alpha-numeric string that is printed on the bottom of the physical personal comfort system. Again, the data is collected on paper forms, brought back to campus and entered into a separate spreadsheet file `subjectDemographicData.xls` located on a second, separate encrypted USB flash drive. Here again, once the data is transcribed from the sheet, the paper copies are destroyed, and like the other drive, this one is also physically secured in a locked drawer, and digitally secured by a password. The same digital and physical measures will secure the demographic data throughout the study. However, unlike the personal data, the Demographic data is not merely administrative, it is needed as part of the research investigation itself. As a result, the demographic data will not be destroyed at the conclusion of the study; it will be associated with the Measured and Survey data at the conclusion of the study as described in section 5.4.5. Although these elements alone or in combination are not sufficient to uniquely identify an individual subject, the release of these personal identifiers could be embarrassing and so they are being collected and stored with the same level of security as personal identifiers to protect subject privacy.

## Measured

Measured (M) Data records the patterns and conditions under which the personal comfort system is used. It is the part of the non-identity data, and comprises the bulk of the research data collected in this study. These data are automatically collected every sixty (60) seconds by the instruments built into the PCS unit and consist of: ambient air temperature, fan setting, footwarmer setting, fan occupancy status, footwarmer occupancy status, fan sleep status and footwarmer sleep status. The measured data is keyed using the pecID and a time stamp and transferred first to the communications client software on the subject’s Personal Computer (PC) via a USB cable, and then on to our research database over a secure internet connection. Details of the data transfer, access and security are described in section “h” below, and the final disposition of this data is described in section 5.4.5.

## Survey

Survey (S) Data records user perceptions of conditions and comfort using a web-based survey. This data includes user responses to questions about thermal sensation and thermal satisfaction. Survey data is part of the non-identity data and will be collected using a



secure web-survey form. Details of the data transfer, access and security are described in section 5.4.5, and the final disposition of this data is described in section 5.4.5.

### **Data Access**

Access to each type of research data is limited to the minimum staff required to conduct the study. In general, only the PI needs access to the keyMap file and the identity dataset. Other researchers, as well as administrative and IT professionals may access the non-identity data throughout the study for research or to maintain and secure the information technology infrastructure.

### **Physical Security**

The keyMap.csv file that links serial numbers to pecID codes is stored on an encrypted volume on the CBE shared drive. This location is separate from both the identity data (which is on two different encrypted USB flash drives) and the non-identity data (stored on a different physical server). The key map is needed only very rarely; it is needed to initially program the Personal Comfort System devices before they are issued, to associate the demographic data with the survey and measured data at the conclusion of the study, and to troubleshoot any problems that may arise in the midst of the study.

Unlike the pecID, the the serial number is plainly visible on the outside of each unit, so it is very important to secure the pecID code stored inside to prevent any possible connection between the two by examining the personal comfort system itself. To achieve this, the pecID code is encrypted before it is written to the PEC's EEPROM memory. That way, even if it were somehow extracted from memory, it would be incomprehensible. The key to decrypt the pecID is secured in memory on the web server, where the incoming data from the systems will be decrypted and placed into the database. See section 5.4.5 for the description of the database security. At the end of the study (after the devices are returned to CBE) all of this personal data will be destroyed as described in section 5.4.5.

### **Digital Security**

In addition to the administrative and personnel measures described above, this protocol includes digital and physical security to protect the integrity and privacy of research data. The measures used to secure this data throughout its collection, transmission and storage are illustrated in figure 5.9. Research data for this study is collected using three methods. Personal and Demographic data are collected in person by the research team using a paper "Research Subject Information Form" and entered into spreadsheets stored on secure USB drives. Survey data is collected through a webpage hosted on our secure server, and Measured data is collected using the instruments built into each Personal Comfort System, and then transferred via secure link to the research database.

The demographic and personal data collected at the start of the study are entered into a spreadsheet located on encrypted removable USB flash drives. Once the data is entered, the paper forms will be destroyed by shredding. The USB drives will be configured as a portable “traveler disk” using TrueCrypt, an open-source, on-the-fly encryption software. The traveler disk contains both the encrypted volume and an unencrypted program file to launch TrueCrypt from the traveler disk even if the software is not installed on that computer. This plan allows the research team to work with the encrypted data entirely in the Random Access Memory of the computer, without ever placing any decrypted data on a disk. The secure data on the USB drive will be encrypted using a cryptographic algorithm that meets the Advanced Encryption Standard (AES). TrueCrypt uses AES with 14 rounds and a 256-bit key operating in XTS mode, which complies with IEEE Std 1619–2007 (“[Standard for Cryptographic Protection of Data on Block-Oriented Storage Devices](#)” 2008), for cryptographic modules. The US National Security Agency protocol found AES–256 sufficient to protect classified information up to the Top Secret level (“[Advanced encryption standard \(AES\) \(FIPS pub 197\)](#)” 2001). Only the PI and student investigator need know the password for this encrypted volume. When not in use at a research site, the USB drive will be physically secured in a locked drawer. The team will make one encrypted backup of the personal and demographic data on an additional secure flash drive. This backup will be stored off-site to hedge against data-loss.

The measured data collected by the instruments on the PCS is keyed using a time stamp, then compressed and stored temporarily in the device’s memory. While not technically encrypted, the compression algorithm makes the data unintelligible to human readers. This data buffer includes at most five days of data, so a person who wished to extract this data from the system itself would need physical access to the specific system every five days, as well as the means to read from the memory, and the correct decompression algorithm. Given these restrictions, a hypothetical malicious person who wished to make nefarious use of the research data could more easily and quickly obtain the same information by observing the subject directly. Periodically, the unit will transmit the compressed data to the subject’s Personal Computer (PC) via a USB cable. The PC communication client software on the PC will temporarily buffer this data on the PC before re-transmitting it via a secure internet connection to the server housing research database using HTTPS (details below). Once the data arrives at the server it is decrypted and placed in the database. In addition to the time stamp attached to the data when it is measured, the data stored in the research database is associated with a specific PCS device using a unique, random twelve-character-alpha-numeric string known as pecID. Before distributing a personal comfort system to the field, that unique pecID is encrypted using the AES algorithm described above and placed in electrically erasable programmable read only memory inside the device. When a device is returned at the end of the study, the team erases the pecID, which is associated with the previous subject, and programs in a new one for the next user.

For the original deployment, we produced a list of four-hundred mutually unique strings for the pecID, which means each device can be wiped, reprogrammed and reissued

multiple times over the course of the study. Eventually more pecIDs will be required, but given the process of generating long, random strings described previously, the odds of accidental overlap should additional strings be generated are incredibly small, and repeated values are easily checked by algorithm.

The encrypted pecID cannot be decrypted at the personal comfort system unit or on the PC client, the block of encrypted data is simply passed to the PC communication client software along with the measured data to be communicated through the secure internet connection to the server where it is decrypted and stored. Given the large number of possible pecIDs, the value is impractical to guess or evaluate by brute force. Furthermore, the server does not retain the subject's IP address or other network information after the communication is finished and the secure link terminated. At no time is the IP address, or other personally-identifiable computer information added to the research database.

The survey data is collected using a secure web-page hosted on the web-server. To collect this data, the communication client software on the subject's PC will prompt the subject to take a survey by following a URL link. Clicking the link establishes a secure connection to the server, opens the survey webpage and automatically transfers the encrypted pecID through that secure connection. When the subject completes the survey and clicks "submit" the survey responses are immediately added to the MySQL database and keyed with the time and pecID. The server does not retain the subject's IP address or other network information after the communication is finished and the secure link terminated. Again, the IP address is not added to the research database.

To create a secure channel across the (non-secure) public internet to either transmit measured data, or present the web survey, the PC client software and webserver make use of Hypertext Transfer Protocol Secure (HTTPS), similar to that used in many online payment systems. HTTPS is a combination of two technologies: the cryptographic protocol known as Transport Layer Security (TLS) creates a secure connection, inside of which conventional HTTP communication takes place. HTTP, the foundation of data communication on the web, is a widely-used protocol for request-response communications between a client and a server. Transport Layer Security uses asymmetric (or public-key) cryptography, in which the encryption key is divided between a public portion used to encrypt the data, and a secure, private portion that is needed to decrypt the data. This means the public portion of the key can be made widely available and need not be secured, while the private key resides safely on the server. When properly implemented with adequate cryptographic algorithms, TLS is considered secure against man-in-the-middle and eavesdropping attacks because at most an attacker can only know the fact that a connection is taking place between the two parties who are already known to him, the domain name and IP addresses involved. The HTTPS protocol makes use of the SHA-256 Secure Hash Algorithm, which was developed by the National Security Agency and complies with Federal Information Processing Standards ("[Secure Hash Standard \(SHS\) \(FIPS pub 180-4\)](#)" 2012). This is the standard for encryption used by Federal Agencies to protect sensitive unclassified government information.

Using HTTPS not only provides a secure pipe and a communications protocol, it allows the Personal Comfort System to connect to the server from essentially any computer that can access the internet. As far as the subject's PC and network are concerned, the PC client is just like a web-browser connecting to a web-server, except rather than transmitting requests and page rendering information, it sends and confirms the research data. Thankfully, each data sample is relatively small at about twelve bytes, so this traffic is incidental to the PC and the network. This is of course important from a practical standpoint of not unduly influencing network traffic, and aids security and anonymity by transmitting amidst a large amount of other traffic.

### Deposition of data

In addition to any immediate study, the data collected represent a potentially useful resource for future investigators. Therefore, the non-identity measured and survey data will not be destroyed at the end of the study. Research data will be associated with the demographic data characterizing the subject who produced it, and then re-keyed for anonymity and retained for future research.

Throughout the study, the survey and measured data is collected and keyed using the encrypted pecID described above while the demographic data is keyed using the personal comfort system's serial number. At the conclusion of the study, researchers use the `keyMap.csv` file to join the age, sex, height and weight of each subject to each stream of survey and measured data. Once this transfer is complete, there is no longer any need to preserve the connection between the study data and any particular personal comfort system, so this newly-assembled dataset of Demographic, Survey, and Measured data will be re-keyed with new unique, random identifiers that replace the pecID. This scrubbed database has no personally-identifiable data, and so may be shared with research faculty, staff and graduate students who make use of data like this in their ongoing projects. For both practical and security reasons, this scrubbed database is removed from the web-server to the internal file-server. Once the transfer is complete, the survey and measured data will be erased from the web server by zeroing out the volume, a quick and relatively secure method for erasing digital media.

The personally identifiable information used to administer the study (and the original demographic data) contained in the `pecDistributionList.xls` file will be destroyed at the end of the study. This protects subject privacy and eliminates any connection between an individual subject and specific system. These data will be destroyed by reformatting the encrypted USB drive on which they are stored using a seven-pass erase method. This method follows the "[National Industrial Security Program Operating Manual](#)" (2013) standards for securely erasing electronic media. Records of individual subjects who wish to end their participation in the study prior to the study completion are individually processed and deleted from the `pecDistributionList.xls` file at the time they withdraw.

The combination of these two measures provide excellent redundant security by sever-

ing both links in the chain that could connect a subject to the study data. First, destroying the distribution lists breaks the connection between an individual subject and a specific personal comfort system device and second, re-keying the scrubbed data eliminates any connection between a personal comfort system device and the study data. After these operations are complete, even a person with access to all the study data, the physical personal comfort system device and the `keyMap.csv` would not be able to connect them to each other, much less to an individual person. Furthermore, even though the final research data contains some demographic characteristics about each subject, it will not be possible to uniquely identify a subject from this data alone.

### **Data Management Conclusion**

This approach to data management and security provides a robust framework of protections for human subjects and the research data which not only satisfies but exceeds minimum institutional requirements. In developing this pilot study and method, we deliberately chose to provide the highest-level of security we could design against every threat we could imagine, in part because it would likely prove difficult to add security to an existing method onto equipment and software that may already be deployed in the field. We hope that future changes to institutional policy, research design, and technology will find the provisions of this framework sufficiently robust and secure to continue to be worthy of our research subjects' trust.

Although quite sophisticated, the technical safeguards of this approach employ only freely-available open-source tools, which allows other researchers to implement these methods fairly readily. More importantly, such tools instill confidence because researchers, institutional review boards or even subjects themselves can vet and verify the code if desired. While these technical measures afford serious protection to the human subject data and make this particular research design possible, these technical measures are meaningless without the corresponding care in administrative and physical safeguards. Commonsense steps to limit data access, generate strong passwords and provide good physical security ensure that any malicious attacker cannot simply circumvent the strong technical measures. More prosaically, and perhaps more usefully, these rigorous procedures help secure the data against carelessness and accident.

# Chapter 6

## Conclusion

### 6.1 Research Outcomes

We designed novel, low-energy local-conditioning devices and iteratively tested them to evaluate and improve performance. The ultimate results include a desktop cooling fan with approximately four times the efficiency of commercially available fan types and a footwarmer that demands approximately one order of magnitude less power than comparable under-desk heaters. We integrated these devices into a new personal comfort system and incorporated sensors, data storage, and communications to allow the systems to serve as research instruments. We produced 100 units for large-scale field testing, and designed a research protocol to collect data about the conditions and patterns of use of the PCS, and to securely transmit it to researchers via internet, setting the stage for the field studies of PCS.

### 6.2 Future Work

Since the work described here includes the development and testing of novel devices, and the design of a field research protocol the major and obvious future work lies in conducting the field study. Additionally, there are some further investigations either supported by this work or that might extend it.

#### 6.2.1 Widen Distribution

The initial research effort focused on California offices, but of course personal comfort systems are applicable all over the country and world. As Wolff (2005) points out, information workers are increasingly global, office parks are springing up all over the world to accommodate workers, many in hot/humid climates with significant cooling loads. In a simulation study, Schiavon, Melikov, and Sekhar (2010) found that substantial savings



(up to 51%) were possible for personalized ventilation in hot-humid climates. The personal comfort system, and the associated research method developed in this project enable a comparative field study across a range of different climates. While the system as designed will work across the United States, minor modifications to electrical components would be required for use in other countries.

Of course not all barriers are technological, so a key element of widening distribution and adoption is understanding the financial and business landscape. In 2012, a group of students enrolled in an entrepreneurship course “Cleantech to Market” in the UC Berkeley Haas School of Business took some steps along this line by conducting a market analysis of the personal comfort system (Dewitt et al., 2012).

## 6.2.2 Improving the Design

While this design of the personal comfort module includes many novel and high-performance features, there are many possible improvements that could be implemented on future versions. The shape and design of the plastic components could be refined for aesthetics, and to reduce the total material required, as well as refining the shape and draw for molding and overall design and features for subsequent assembly. Among other things, the screw-together base was fragile and slow to assemble: a set of simple snap-hooks operating on the reveal where the upper and lower parts connect would take advantage of the flexibility of the plastic to simply snap together for fast assembly. Designed properly, a gentle push from a tool could move them out of place to allow disassembly for service and repair. This change would also accommodate selecting different rubber feet used on the base which were designed to press-fit into the screw holes but too often fell out, even when adhered with glue. Alternatively, there may be other formal and material expressions for the fan, as explored in version 3 “woodie” that are worth exploring once the basic technology is validated. Similarly, larger fans, as tested in version 2.X and validated in the CFE measurement may offer solutions to comfort challenges in less traditional workspaces. The form of the footwarmer led to some user complaints about striking their shins on the front face. These were addressed in early studies by adding some foam padding to this location, but a revised design might remove material and replace with a softer or elastic enclosure.

The electronics in both the fan and the footwarmer evolved over the course of the project; a comprehensive review might produce a simpler, less-expensive and more robust design. The most important single upgrade would be to replace the temperature sensor. At the very least the TMP37 would be a better sensor than the TMP36, and could be added with only a few minor changes to the code, and no change to the physical assembly since it has the same form factor. Other sensors may offer even better performance. On the footwarmer, the x10 interface works well enough, but is a nearly forty-year-old protocol with significant limitations on bandwidth, two-directional communications and increasingly limited availability of components. A revised design might consider the IN-

STEON system from Smartlabs or similar innovations, or perhaps move to some other lamp-dimming device. One of the most time consuming and error-prone steps in this design is connecting the mini-DIN jacks to the micro-controller at the fan end, and to the RJ-11 phone jack that plugs into the x10 interface module. While the mini-DIN was selected specifically because it was unusual and users would be unlikely to connect the parts of the system to anything except each other, this fear is most likely overblown. Furthermore, length and cost of available mini-DIN cables was occasionally an issue for fan setup. Future designs should consider using RJ-11 or CAT-5 type cables for all the connections. These cables are widely available or quick to fabricate in any length desired. They would replace two labor-intensive soldered connections with simple, reliable and fast crimp-on terminations and fairly standard tools, reducing both cost and complexity of assembly. Finally, our fans were assembled using a mixture of cut wire and purchased jumpers wires with terminal ends. Future production runs would save significant time and more importantly reduce errors and failures by purchasing color-coded jumpers for all connections to reduce soldering and bad terminations.

A future high-volume production run would doubtless simplify the electronics by putting all functions (including the MOSFET, PIR circuit, additional memory for buffering etc.) onto a single custom chip. This could have more memory, more analog inputs and finer resolution than the Arduino used in these models. An intermediate step might be to upgrade to a more advanced micro-controller which has some of these desirable features. Upgrades along that line might demand a substantial code overhaul as well, of both the code that runs on the hardware, and the software installed on the PC for the data collection. Software updates would also provide the opportunity to convert the data structure to use a standard protocol, such as the Simple Measurement and Actuation Profile (sMAP) designed for web-connected devices and instruments (Dawson-Haggerty et al., 2010).

### 6.2.3 Improving the research method

One major limitation of the research protocol outlined here is the reliance on paper forms to collect the demographic research data. A superior design would collect the demographic data in a one-time digital survey at the beginning of the study period; automatically associating it with the measured data from the beginning, it would be secure, private, and very nearly anonymous. This conceptually preserves the idea that all research data is collected digitally and secured, while all personal administrative information used for the administration of the study is collected on paper and in person.

Like many others, the study protocol outlined here surveys the participants about a specific moment in time. Those survey prompts occur at random intervals throughout the study period, and while it is convenient that the researcher need not go in person to ask the questions or measure the data, the connection is primarily one-directional. However, the fact that the devices are networked as well as distributed offers the possibility for real-

time feedback and possible responses, which opens new research opportunities.

One key question about personal comfort systems is why people change the personal settings when they do. Given real-time feedback, the system could automatically prompt for the right-now survey when a user operates their personal controls, and that survey could be customized to the exact behavior. For example, an increased fan speed might trigger questions such as “what is your sensation now? What led you to increase the speed? Is the speed sufficient, or are you still too hot?” Furthermore, monitoring the sensations and PCS use of surrounding PCS occupants might cause the system to prompt for a survey when it notices that others in the area seem to be experiencing discomfort to get at why people have not yet taken action. These so-called “thresholds of discomfort” are one element that makes simulating human behavior so difficult. Ackerly (2011) itemizes four possible motivations to change, and notes that “Adrian Leaman likes to make the point, first introduced by Haigh (1981), about a “crisis of discomfort,” that is, that many people will wait quite a while even after becoming uncomfortable to take an action.” While this somewhat Bayesian approach to experimental design would be unconventional, it would likely offer a richer picture of human response to the thermal environment when given some amount of control over it.

Perhaps even more interesting, the two-directional communication, coupled with the flexible and extensible Arduino platform opens a range of possibilities to change the personal comfort system after deployment. Even prior to deployment, this capability served pragmatic ends, for example delivering updates and bug fixes via the internet. It also enables powerful research protocols that can include double-blind testing. For example, the researchers could instruct the server to select a random set of devices for an intervention, and then program them with a new behavior (e.g. dynamic fan velocity to mimic natural wind). The update can be invisible to the researchers, the affected users, and to the control group until after the analysis is complete.

Rather than compare between groups, these intervention studies could compare a number of very short test periods for the same user. For example, the devices could be secretly re-programmed to alternate their behavior in some small way each day, perhaps reducing the top fan velocity one day, and then restoring it the next. That approach would allow a direct comparison of the same subject both with and without the intervention. This design could even limit the Hawthorne and other order effects and external factors by mixing the treatment and non-treatment sessions together throughout the study period.

#### **6.2.4 Future Integration**

The study described here assumes that the personal comfort systems are placed into an office environment with expanded comfort zones (increased dead band) and used to provide additional comfort in the over and under heated periods as set by the system designer and operator. However, if the PCS data is tied in realtime to the Building Management

System, the centralized HVAC system itself can adopt a personalized approach to thermal comfort, and those boundaries need not be pre-determined, nor even be fixed. In the first case, called voter control, occupants who use personal comfort systems are essentially voting about their thermal comfort each time they adjust the system. A smart Building Management System (BMS) could tally these votes of dissatisfaction and decide if it is more efficient to adjust the whole building system or continue to let people adjust to their comfort individually. Thus, the system dead-band is set dynamically by the needs of the occupants. The second case is an interesting extension of this logic into an intervention regime (either for study or in practice) that actually adjusts the space temperature slowly over time, waiting until a spike in PCS use signals that a threshold of discomfort has been reached. Using machine learning, these data would allow the BMS to adjust ambient conditions and optimize the trade-off between comfort and energy savings, particularly in complex thermal and energy environments such as areas with demand response. These ideas would reinforce an approach to buildings and conditioning that is not merely smarter, but also more human-centric, and perhaps more humane.

## References

- Ackerly, Katie (2011). "Field Protocol Comparison". Private Communication.
- "Advanced encryption standard (AES) (FIPS pub 197)" (2001). In: *Federal Information Processing Standards Publication 197*, pp. 441–0311. URL: <http://csrc.nist.gov/publications/fips/fips197/fips-197.pdf>.
- Arens, Edward A., Zhang, Hui, Wilmer Pasut, Ashley Warneke, Fred Bauman, and Hiroshi Higuchi (Aug. 2011). "Thermal comfort and perceived air quality of a PEC system". In: *Indoor Air*.
- Army-GL (Sept. 1992). *Fans, Ventilating, Propeller*. Commercial Item Description A-A-50032B. US Department of Defense.
- Arnold, David (1999a). "Air Conditioning in Office Buildings After World War II". In: *ASHRAE journal* 41.7, p. 7.
- (1999b). "Evolution of Modern Office Buildings and Air Conditioning". In: *ASHRAE journal* 41.6, p. 10.
- ASHRAE (2004). *Standard 55-2004: Thermal Environmental Conditions for Human Occupancy*. Atlanta: American Society of Heating, Refrigerating Air-Conditioning Engineers.
- Attia, M and P Engel (1981). "Thermal alliesthesial response in man is independent of skin location stimulated". In: *Physiology & behavior* 27.3, pp. 439–444.
- Banham, Reyner (1984). *Architecture of the Well-tempered Environment*. University of Chicago Press.
- Bauman, Fred, T. Carter, A. Baughman, and E.A. Arens (1998). "Field Study of the Impact of a Desktop Task/Ambient Conditioning System in Office Buildings". In: *ASHRAE Transactions* 104.1.
- Benjamin, Walter (1968). "Illuminations". In: ed. by Hannah Arendt. Trans. by Harry Zohn. New York: Fontana, pp. 214–218.
- Better Buildings Department of Energy*. URL: <http://energy.gov/better-buildings> (visited on 12/04/2014).
- Bohm, M, A Browen, I Holmer, H Nilsson, and O Noren (1990). "Evaluation of vehicle climate with a thermal manikin. The relationship between human temperature experience and local heat loss". In: *JTI-Rapport (Sweden)*.

- Cabanac, M, B Massonnet, and R Belaiche (1972). "Preferred skin temperature as a function of internal and mean skin temperature." In: *Journal of Applied Physiology* 33.6, pp. 699–703.
- Dawson-Haggerty, Stephen, Xiaofan Jiang, Gilman Tolle, Jorge Ortiz, and David Culler (2010). "sMAP: a simple measurement and actuation profile for physical information". In: *Proceedings of the 8th ACM Conference on Embedded Networked Sensor Systems*. ACM, pp. 197–210.
- Dewitt, Katie, Chris Hallas, Anna Maybank, Anoop Honnekeri, and Ankit Jain (2012). *Cleantech to Market Final Report: Personal Comfort Systems (PCS)*. Cleantech to Market Final Report. UC Berkeley.
- Fanger, Poul O (1970). *Thermal comfort: Analysis and applications in environmental engineering*. Copenhagen: Danish Technical Press.
- Frontczak, Monika, Stefano Schiavon, John Goins, Edward Arens, Hui Zhang, and Pawel Wargocki (2012). "Quantitative relationships between occupant satisfaction and satisfaction aspects of indoor environmental quality and building design". In: *Indoor Air* 22.2, pp. 119–131.
- GSA-FSS (1998). *Fan, Circulating, (Desk/Floor And Wall Mounted, Oscillating)*. Commercial Item Description, A-A- 1939B. US Department of Defense.
- Haahr, Mads. *random.org*. URL: [www.random.org](http://www.random.org).
- Haigh, Diane (1981). "User response in environmental control". In: *The Architecture of Energy*, pp. 45–63.
- Holmér, Ingvar (2004). "Thermal manikin history and applications". In: *European journal of applied physiology* 92.6, pp. 614–618. URL: <http://link.springer.com/article/10.1007/s00421-004-1135-0#page-1>.
- Hoyt, T., K.H. Lee, H. Zhang, E. Arens, and T. Webster (2009). "Energy savings from extended air temperature setpoints and reductions in room air mixing". In: *International Conference on Environmental Ergonomics*.
- Hoyt, Tyler, Edward Arens, and Hui Zhang (2014). "Extending air temperature setpoints: Simulated energy savings and design considerations for new and retrofit buildings". In: *Building and Environment*.
- Huizenga, C., S. Abbaszadeh, L. Zagreus, and E. Arens (2006). "Air quality and thermal comfort in office buildings: results of a large indoor environmental quality survey". In: *Proceedings of Healthy Buildings*. Vol. 3. Healthy Buildings. Lisbon, pp. 393–397. URL: <http://www.escholarship.org/uc/item/7897g2f8>.
- Huizenga, Charlie, Hui Zhang, and Edward Arens (2001). "A model of human physiology and comfort for assessing complex thermal environments". In: *Building and Environment* 36.6, pp. 691–699.
- Kim, Jungsoo, Richard de Dear, Christhina Candido, Hui Zhang, and Edward Arens (2013). "Gender differences in office occupant perception of indoor environmental quality (IEQ)". In: *Building and Environment* 70, pp. 245–256.



- Kroemer, K.H.E. (2001). *Office Ergonomics*. Office Ergonomics. Taylor & Francis. ISBN: 9780748409525. URL: <http://books.google.com/books?id=buZ1F54Km3sC>.
- Kroner, Walter M. (2006). "Employee Productivity and the Intelligent Workplace". In: *Creating the Productive Workplace*. Ed. by Derek Clements-Croome. 2nd Ed. London: Taylor & Francis, pp. 348–356. ISBN: 0415351375.
- Kroner, Walter M. and Jean A. Stark-Martin (1994). "Environmentally responsive workstations and office-worker productivity". In: *Proceedings of the ASHRAE Annual Meeting, June 25, 1994 - June 29, 1994*. Vol. 100. ASHRAE Transactions. Compendex. Orlando, FL, USA: ASHRAE, pp. 750–755. ISBN: 00012505.
- Malmstro, Tor G., Allan T. Kirkpatrick, Brian Christensen, and Kevin D. Knappmiller (1997). "Centreline velocity decay measurements in low-velocity axisymmetric jets". In: *Journal of Fluid Mechanics* 246, pp. 363–377.
- McGuffin, Rom, Rick Burke, Charley Huizenga, Zhang Hui, Andreas Vlahinos, and George Fu (June 2002). *Human thermal comfort model and manikin*. Tech. rep. SAE Technical Paper.
- Mower, George D (1976). "Perceived intensity of peripheral thermal stimuli is independent of internal body temperature." In: *Journal of comparative and physiological psychology* 90.12, p. 1152.
- "National Industrial Security Program Operating Manual" (2013). In: *DoD 5220.22-M*. URL: <http://www.dtic.mil/whs/directives/corres/pdf/522022m.pdf>.
- Parkinson, Thomas and Richard de Dear (2014). "Thermal pleasure in built environments: physiology of alliesthesia". In: *Building Research & Information* ahead-of-print, pp. 1–14.
- Schiavon, Stefano and Arsen K. Melikov (May 2009a). "Energy-saving strategies with personalized ventilation in cold climates". In: *Energy and Buildings* 41.5, pp. 543–550. ISSN: 0378-7788. DOI: [10.1016/j.enbuild.2008.11.018](https://doi.org/10.1016/j.enbuild.2008.11.018). URL: <http://www.sciencedirect.com/science/article/B6V2V-4V2NP1R-4/2/68d04335ba9a3b9ccb994acb3b430e11>.
- (2009b). "Introduction of a Cooling Fan Efficiency Index". In: *HVAC R Research* 15. URL: <http://www.escholarship.org/uc/item/4ph1m7t5?display=all>.
- Schiavon, Stefano, Arsen K. Melikov, and Chandra Sekhar (2010). "Energy analysis of the personalized ventilation system in hot and humid climates". In: *Energy and Buildings* 42.5, pp. 699–707. ISSN: 0378-7788. DOI: [10.1016/j.enbuild.2009.11.009](https://doi.org/10.1016/j.enbuild.2009.11.009). URL: <http://www.sciencedirect.com/science/article/pii/S037877880900293X>.
- "Secure Hash Standard (SHS) (FIPS pub 180-4)" (2012). In: *Federal Information Processing Standards Publication 180-4*, pp. 20899–8900. URL: <http://csrc.nist.gov/publications/fips/fips180-4/fips-180-4.pdf>.
- "Standard for Cryptographic Protection of Data on Block-Oriented Storage Devices" (2008). In: *IEEE Std 1619-2007*, pp. c1–32. DOI: [10.1109/IEEESTD.2008.4493450](https://doi.org/10.1109/IEEESTD.2008.4493450).
- Tanabe, S, Edward A Arens, Fred Bauman, H Zhang, and T Madsen (1994). "Evaluating thermal environments by using a thermal manikin with controlled skin surface temperature". In: *Center for the Built Environment*.

- Taub, Mallory, Hui Zhang, Edward Arens, Fred Bauman, Darrell Dickerhoff, Marc Fountain, Wilmer Pasut, David Fannon, Yongchao Zhai, and Margaret Pigman (2015). "The use of footwarmers in offices for thermal comfort and energy savings in winter". In: UC Berkeley Committee for Protection of Human Subjects. *Human Research Protection Program*. URL: <http://cphs.berkeley.edu/>.
- US Department of Energy (2011). *Buildings Energy Data*. Tech. rep. Building Technology Program. URL: <http://buildingsdatabook.eren.doe.gov/>.
- US Department of Energy Energy Information Agency (2010). *International Energy Statistics*. URL: <http://buildingsdatabook.eren.doe.gov/>.
- Wilson, John R. (2000). "Fundamentals of ergonomics in theory and practice". In: *Applied ergonomics* 31.6, pp. 557–567.
- Wolff, E.N. (2005). "The growth of information workers in the US economy". In: *Communications of the ACM* 48.10, pp. 37–42.
- Wyon, David P, S Larsson, B Forsgren, and I Lundgren (1989). *Standard procedures for assessing vehicle climate with a thermal manikin*. Tech. rep. SAE Technical Paper. URL: <http://papers.sae.org/890049/>.
- Zhai, Yongchao, Yufeng Zhang, Qinglin Meng, Huimei Chen, and Jinyong Wang (2014). "Gender differences in thermal comfort in a hot-humid climate". In: *Proceedings of the 13th International Conference Indoor Air 2014*.
- Zhang, Hui (2003). "Human thermal sensation and comfort in transient and non-uniform thermal environments". PhD thesis. UC Berkeley. URL: <http://www.escholarship.org/uc/item/11m0n1wt>.
- Zhang, Hui, Charlie Huizenga, Edward Arens, and Danni Wang (2004). "Thermal sensation and comfort in transient non-uniform thermal environments". In: *European journal of applied physiology* 92.6, pp. 728–733. URL: <http://link.springer.com/article/10.1007/s00421-004-1137-y>.
- Zhang, Hui, Edward Arens, DongEun Kim, Elena Buchberger, Fred Bauman, and Charlie Huizenga (Jan. 2010a). "Comfort, perceived air quality, and work performance in a low-power task-ambient conditioning system". In: *Building and Environment* 45.1, pp. 29–39. ISSN: 0360-1323. DOI: 10.1016/j.buildenv.2009.02.016. URL: <http://www.sciencedirect.com/science/article/B6V23-4VRX647-1/2/6844a0d92e1906579dbe104650c5e4ab>.
- Zhang, Hui, Edward Arens, Charlie Huizenga, and Taeyoung Han (2010b). "Thermal sensation and comfort models for non-uniform and transient environments: Part I: Local sensation of individual body parts". In: *Building and Environment* 45.2, pp. 380–388.
- (2010c). "Thermal sensation and comfort models for non-uniform and transient environments, part II: local comfort of individual body parts". In: *Building and Environment* 45.2, pp. 389–398.
- (2010d). "Thermal sensation and comfort models for non-uniform and transient environments, part III: whole-body sensation and comfort". In: *Building and Environment* 45.2, pp. 399–410.

# **Appendix A**

## **Fan Specification**

## PERFORMANCE SPECIFICATION

FAN, LOW POWER  
(DESKTOP MOUNTED OR WORKSTATION INTEGRATED.  
FOR OCCUPANT COOLING)

NOTE: This draft prepared by the U.C. Berkeley Center for the Built Environment has not been approved and is subject to modification.

DO NOT USE FOR ACQUISITION PURPOSES.

## 1 SCOPE AND CLASSIFICATION

- 1.1 Scope. This specification describes the performance characteristics of low-power fans for cooling the occupants in office workstations.
- 1.2 Use. The fan described is for use at an office workstation by individual workers to provide thermal comfort through air movement.
- 1.3 Classification. The fan shall be of the following types and styles as specified.
  - 1.3.1 Type I: Above-worksurface fans. Fans positioned on, integrated with, affixed on or mounted above the worksurface and primarily directed at the breathing zone and upper chest of the user.
  - 1.3.2 Type II: Below-worksurface fans. Fans integrated with furniture or mounted below the worksurface and primarily directed at the lap and lower trunk region of the user.
  - 1.3.3 Class 1: Discrete Control
  - 1.3.4 Class 2: Continuous Control

## 2 APPLICABLE DOCUMENTS

- 2.1 Government Publications. The following documents, of the issues in effect on the date of invitation for bids or request for proposal, form a part of this specification to the extent specified herein:
  - 2.1.1 Federal Specifications (with appropriate sourcing paragraphs!)
  - 2.1.2 Federal Standards (with appropriate sourcing paragraphs!)
  - 2.1.3 Commercial Item Descriptions
  - 2.1.4 Military Specifications
  - 2.1.5 Military Standards (with appropriate sourcing paragraphs!)
  - 2.1.6 Military Handbooks (with appropriate sourcing paragraphs!)
  - 2.1.7 Federal Regulations (with appropriate sourcing paragraphs!)

## Thermal Ergonomic Desk Fans

2.2 Other publications. The following documents form a part of this specification to the extent specified herein. Unless a specific issue is identified, the issue in effect on date of invitation for bids or request for proposal shall apply.

2.2.1 Voluntary Standard. This will be the itemized list of applicable codes and standards from UL, CE, ASTM, FCC etc. (with appropriate sourcing paragraphs!)

### 3 REQUIREMENTS

3.1 Air Movement. Fans shall conform to the air movement characteristics specified in paragraph 3.1.1 through 3.1.3.

3.1.1 Air Velocity. Fans shall maintain the air velocities specified with a tolerance of  $\pm 10\%$  when tested in their installed configuration and directed at the workstation occupant's normal seated position as described in the contract or order and section 3.3.2.

a The maximum air velocity shall be not less than 2.5 m/s.

b The minimum air velocity shall be not greater than 0.3 m/s.

c Air velocities for Type I (Above-worksurface) fans shall be measured at the location of the occupant's head when seated at the workstation with the fan adjusted to direct the airflow directly at the head.

d Air velocities for Type II (Below-worksurface) fans shall be measured at a distance of 0.15 m along the centerline of the occupant's body when seated at the workstation.

3.1.2 Air Volume. The volume of air delivered through the fan outlet shall be not less than ten (10) liters per second  $\pm 10\%$  when operated at maximum velocity.

3.1.3 Filtration. (Optional feature.) If included in contract documents or order, provide fibrous, cellular or electrostatic filters as specified.

3.2 Energy and power.

3.2.1 Power. The continuous power consumption of the fan shall be no more than four (4) watts at all operating speed settings.

3.2.2 Standby Power. Continuous power consumption in the standby mode described in paragraph 3.3.4 shall be no greater than 0.2 watts.

3.2.3 Voltage and Frequency. Unless otherwise specified, the fans shall be designed to connect to a rated voltage of 120 volts alternating current  $\pm 10$  percent, and a rated frequency of 60 hertz  $\pm 5$  percent.

3.2.4 Power Harmonics. Fans shall return power harmonics that do not exceed acceptable levels to the building electrical system when operated across all speeds.

## Thermal Ergonomic Desk Fans

3.3 User interface.

- 3.3.1 Speed control. Fan speed shall be adjusted via user controls in order to produce the air velocities as specified in paragraph 3.1.1.
- a Class 1 Fans (discrete velocity control) shall include 'off' and not fewer than three 'on' speed positions. Class 2 Fans (continuous velocity control) shall include a positive 'off' position as well as the specified range of continuous control.
  - b Fan speed controls shall be operable with one hand and require no tight grasping, pinching or twisting of the wrist. Operation of the control shall require no more than 2 newtons of force.
  - c Fan speed controls shall be within easy reach of the normal workstation position. Forward reach shall be no more than 635 mm and the vertical reach shall be not more than 1120 mm above the floor.
- 3.3.2 Direction Control. Fans shall permit users to manually direct the air stream by adjustment or repositioning to accommodate differences among users and changes of posture. Once directed, fans shall remain stable until manually repositioned.
- a Fan direction controls shall be within easy reach of the normal workstation position. Forward reach shall be no more than 635 mm and the vertical reach shall be not more than 1120 mm above the floor.
  - b Direction controls shall be operable with one hand and require no tight grasping, pinching or twisting of the wrist. Operation of the control shall require no more than 22.2 newtons of force.
  - c Type I: (Above-worksurface) Fans shall include a vertical adjustment sufficient to direct the air stream across a range from the user's hands on the worksurface to the top of the user head. Fans shall be repositionable across a horizontal range encompassing normal seating positions of the workstation.
  - d Type II: (Below-worksurface) Fans shall provide air movement on the lap and lower trunk region while the occupant is in the normal seating position of the workstation.
- 3.3.3 Automatic off. When the workstation becomes unoccupied, the fan shall switch automatically to 'off' or 'standby' after a latency period of no more than ten minutes. When the workstation is reoccupied, the fan shall immediately return to the previous speed setting without additional user input.
- a Optional feature. The latency period shall be user adjustable in one-minute increments from a minimum of one minute to a maximum of fifteen minutes. Adjustment shall not require special tools or computer interface.
- 3.3.4 Safety. The fan shall protect the user and other employees from contact with hazards such as rotating blades, electrical current and pinch points.



## Thermal Ergonomic Desk Fans

3.4 Occupancy sensing

3.4.1 Sensor Field of View. The Field of View (FOV) for occupancy/vacancy detection sensors shall be limited to the user-inhabited portion of the workstation.

- a Optional feature: Sensors may be adjustable to limit the FOV. FOV adjustments shall not require special tools.

3.4.2 Passive Sensing. Fan sensors shall emit no electromagnetic, acoustic or other signal in order to detect occupancy.

3.5 Acoustics.

3.5.1 Sound Pressure Level. The fan shall produce a sound pressure level not greater than 25 decibels measured using the A-weighted scale at a distance of one meter over the entire range of available speed settings.

3.5.2 Frequency Distribution. The fan shall operate without unpleasant harmonic tones or physical vibration at all operating speeds.

3.6 Operational Environment.

3.6.1 Continuous Operation. The fan shall be capable of continuous operation without overheating or other failure.

3.6.2 Temperature Range. The fan shall operate in ambient temperatures between 0° C and 40° C.

3.6.3 Placement or Attachment. Fans shall be placed or affixed such that they remain stationary.

- a Type I (Above-worksurface fans) designed to be placed on the desk shall be rest securely on the worksurface and be of sufficient weight and strength that they remain stationary at all operating speeds and whilst being adjusted or controlled.
- b All Type II (Below-worksurface fans) as well as those Type I (Above-worksurface fans) designed to be integrated with, affixed on or mounted above the worksurface shall incorporate mounting hardware of sufficient strength such that the fan remains stationary at all operating speeds and whilst being adjusted or controlled.

3.7 Design and Construction. Fans covered by this document shall include all components necessary to constitute a complete and functional product.

3.7.1 Materials. The fan and all its component parts shall be constructed of materials sufficiently durable for their purpose and the expected service life of not less than 10 years according to manufacturers standard commercial practice.

3.7.2 Recovered materials. The offer or/contractor is encouraged to use recovered materials in accordance with Public Law 94-580 to the maximum practical extent. Recycled or reclaimed materials maybe used in the construction of the equipment described herein. Under no conditions or circumstances shall the contractor

## Thermal Ergonomic Desk Fans

submit to the Government for acceptance reconditioned or rebuilt components as a part of the equipment described herein.

3.7.3 Cleaning. Air filters (if present) should be removable, replaceable, and interchangeable without the use of special tools.

3.8 Codes and Standards. Fans covered by this document shall conform to the applicable requirements of the codes and standards specified in 3.5.1 through 3.5.10.

3.8.1 NFPA. Wiring shall conform to National Fire Protection (NFPA) Standard No. 70. The National Electrical Code.

3.8.2 NEMA. Motors shall conform to National Electrical Manufacturers Association (NEMA) Publication No. MG- 1.

3.8.3 UL. Fans shall conform to the requirements of Underwriters Laboratories Inc. (UL) Standard No. UL 507.

3.8.4 Occupational Safety. Fans shall conform to Occupational Safety and Health Act (OSHA), 29 CFR 1910.

3.8.5 Indoor Air Quality. Fans shall conform to the provisions of California Green Specification section 01350.

## 4 QUALITY ASSURANCE

4.1 Product conformance. The product offered shall meet the performance requirements of specification, and conform to the producer's own drawings, specifications, standards and quality assurance practices. When specific quality assurance provisions are specified for any characteristic, the contractor shall maintain records resulting from inspection(s) and testing conducted in accordance with the specific quality assurance provisions. The government reserves the right to require proof of such conformance prior to first delivery and thereafter as may be otherwise provided under the provisions of the contract. The government reserves the right to audit the contractor's quality assurance records.

4.2 Place and date of manufacture. Each fan shall bear an alpha-numeric code to indicate the manufacturer's plant where produced and the date that production occurred. This encoded information shall be permanently stamped or affixed to the fan.

4.3 Warranty. Unless otherwise specified in the contract, the manufacturer's standard commercial warranty terms shall apply. The warranty shall become effective from the date of start up of the equipment after installation is complete.

4.4 Quality Control. A representative random sample of fans drawn from each production run shall be tested to ensure they satisfy the provisions of the specification.

4.4.1 Air Velocity. Fans shall be tested to deliver the air velocities as specified in section 3.1.1. Velocity measurements will be taken over a period of not less than two minutes for each velocity setting.

4.4.2 Power Consumption. Fans will be tested that they do not exceed operating or standby power limits specified in section 3.2. Continuous power consumption will

## Thermal Ergonomic Desk Fans

be measured at the plug by averaging the values measured at an interval of no more than one second over a testing period of not less than ten minutes.

4.4.3 Comfort. Human subject test? Mannequin?

## 5 PACKAGING

5.1 Packaging. Requirements for preservation, packing, packaging, and marking of packages shall be as specified in the contract or order.

## 6 NOTES AND CONCLUDING REMARKS

6.1 CBE Examples. The Center for the Built Environment (CBE) at the University of California, Berkeley has constructed a number of prototype devices.

6.2 Relevant Scientific Literature. We will site the forthcoming Corrective Power Paper, which will give a nice review of the state of the literature. In the future we can add documentation about this process.

# **Appendix B**

## **Consent Form**

UNIVERSITY OF CALIFORNIA AT BERKELEY

BERKELEY • DAVIS • IRVINE • LOS ANGELES • RIVERSIDE • SAN DIEGO • SAN FRANCISCO



SANTA BARBARA • SANTA CRUZ

CENTER FOR ENVIRONMENTAL DESIGN RESEARCH  
390 WURSTER HALL, #1839

BERKELEY, CALIFORNIA 94720

**Consent to Participate in Research**  
**A pilot study of low-energy personal thermal control systems**

**Introduction**

We are Graduate Student Researcher David Fannon, Professor Edward Arens, and Research Scientist Hui Zhang from the Center for the Built Environment at the University of California Berkeley. We are researching the use of personal heating and cooling to improve comfort and save energy in buildings. We invite you to participate in a study of the use of personal, low-energy thermal conditioning devices by office workers.

**Procedures**

If you agree to participate, you will be provided with a Personal Environmental Control System (PEC) at your workstation to use for the duration of the study. The system consists of a small desktop fan for cooling, and an under-desk footwarmer for heating. You will always have individual control over when and how you use these components to contribute to your comfort, so using the system should not cause you any physical risks or discomfort.

To collect the data for our research, the system incorporates sensors that automatically record the settings you choose for the fan and footwarmer, the air temperature around your desk and whether or not your workstation is occupied. A software program on your computer encrypts and forwards this information to our database. Additionally, every few days you will be asked (by either a prompt on your computer or an email) to take a short online survey about your thermal sensations and comfort. Each survey takes between one and two minutes to complete. We will suggest times of day that we would like you to take the survey and you will have freedom to fit it into your schedule as best you can. Your management has agreed to allow employees who choose to participate in the study to do so during work hours on that basis. The survey questions should cause you no physical risks or discomfort. Finally, it is very helpful to the study outcome to categorize our findings based on demographic attributes, so we will ask you to complete a brief demographic questionnaire when you enroll in the study. All of the research data we collect will be kept as confidential as possible, as described below.

**Benefits**

If you choose to participate in this study, we will provide you with a Personal Environmental Control System to use the duration of the study at no cost, which may increase your thermal comfort. There are no other direct benefits or compensation as a result of participating in the study. The results of the research will be used to refine the design of Personal Environmental Control Systems, and to develop industry standards for using these systems in future buildings to provide greater comfort and energy efficiency. Studies like this have been instrumental to recent progress in making buildings more sustainable.

**Risk**

Because you will decide if and when to use the personal environmental control system, and will control how you use it, we do not anticipate any physical risk or discomfort as a result of this study. As with any study, there is a possibility that the confidential data you entrust to us could be compromised. While we believe such a breach is unlikely, and the potential harm small, we have included strong administrative, physical and technical safeguards to protect your confidential information as described in the "Confidentiality" section below.

**Confidentiality**

Your study data will be handled as confidentially as possible and only our team at UC Berkeley will access or analyze this data. We will record directory information like your name, address, email and telephone number so we can administer the study, troubleshoot any problems with the PEC system and collect the system at the end of the study (or whenever you withdraw.) After the system is returned, we will destroy the record of that directory information.

The measurements taken automatically by the PEC system and the responses to the survey do not contain personally-identifying information (e.g. your name, computer IP address) instead they are organized using a unique identity number encoded inside the PEC system. The measurements and the survey results are encrypted and transmitted to our server over secure internet connections similar to those used for online banking. Individual survey responses and measured data will never be shown to or discussed with your management or building operator.

The demographic data you share with us also does not include your name or office site, and is organized using a second, unique serial number. Paper forms used to gather that data will be destroyed as soon as the information is transcribed into a secure digital location. At the end of the study we will remove all personal identifiers and codes from all data and store this anonymized data for use in future research projects. Of course, whenever the results of this study are published or presented, individual names and other personally identifiable information will not be used.

**Rights**

Participation in this research study is completely voluntary. You have the right to decline to participate or to withdraw at any point in this study without penalty or loss of benefits to which you are otherwise entitled. Neither participating, nor declining to participate in this study will affect your employment status. The choice to participate or not is entirely up to you.

**Questions**

If you have any questions about this research at any time, you may contact David Fannon at [david.fannon@berkeley.edu](mailto:david.fannon@berkeley.edu), or Hui Zhang at 510-642-6918. If you have any questions about your rights as a research participant in this study, please contact UC Berkeley's Committee for the Protection of Human Subjects at (510) 642-7461, or email: [subjects@berkeley.edu](mailto:subjects@berkeley.edu).

**Consent**

If, after considering this information you wish to participate in the study, please indicate your understanding and agreement by signing below. Please detach the additional copy of this form and keep it for your future reference.

---

 Signature

---

 Date

---

 Name (please print)



## **Appendix C**

### **Contact Information Form**

A pilot study of low-energy personal thermal control systems

Form A

**Form A: Contact Information**

**Introduction**

To administer the study, troubleshoot any problems with the PEC system and collect the system at the end of the study (or whenever you withdraw) we need to know how to contact you. Once the system with the serial number below is returned, we will destroy the record of this directory information. As with all of the research data we collect, your contact information below will be kept as confidential as possible, as described in the *Consent to Participate in Research*.

**Fan Serial Number**

Please write the three-digit serial number printed on the bottom of your fan (e.g. F-007):

F-

**Contact Information**

Please print the following information or attach a business card.

\_\_\_\_\_  
Name Office or Company

\_\_\_\_\_  
Address

\_\_\_\_\_  
Email Phone

Thank you, we appreciate your help.

## **Appendix D**

# **Personal Information Questionnaire**

A pilot study of low-energy personal thermal control systems

Form B

**Form B: Personal Characteristics****Introduction**

It is very helpful for the study outcome and future research to categorize the study data based on demographic attributes. As with all of the research data we collect, your responses below will be kept as confidential as possible, as described in the *Consent to Participate in Research*.

**Fan Serial Number**

Please write the three-digit serial number printed on the bottom of your fan (e.g. F-007):

F- <input type="text"/> <input type="text"/> <input type="text"/>
---

**Characteristics**

Please enter the following information about yourself:

Age:  yearsWeight:  poundsSex:  femaleHeight:  feet  inches male

Thank you, we appreciate your help.

## **Appendix E**

# **Information Technology Guide**

### IT-Guide to the CBE Personal Environmental Control System

Personal Environmental Control Systems (PECS) provide local thermal comfort for individuals, rather than conditioning whole spaces, promising increased occupant satisfaction while reducing energy consumption. This guide describes the software and systems built into the Center for the Built Environment (CBE) PECS, and some of the implications for the IT infrastructure that hosts them. The CBE system is a research tool, designed to collect data and transmit it to a central database, which has particular implications for the hardware, software and network that makes it possible.

#### Structure:

The Information Technology for this study consists of three main components: the PECS unit located at each subject’s workstation which collects data; the research subject’s Personal Computer (PC) which transmits data from the PECS unit to the research server; and the CBE webserver/database, where data is stored. These parts work together to collect, secure, transmit and store the research data as illustrated in the “PEC Data Plan” below:

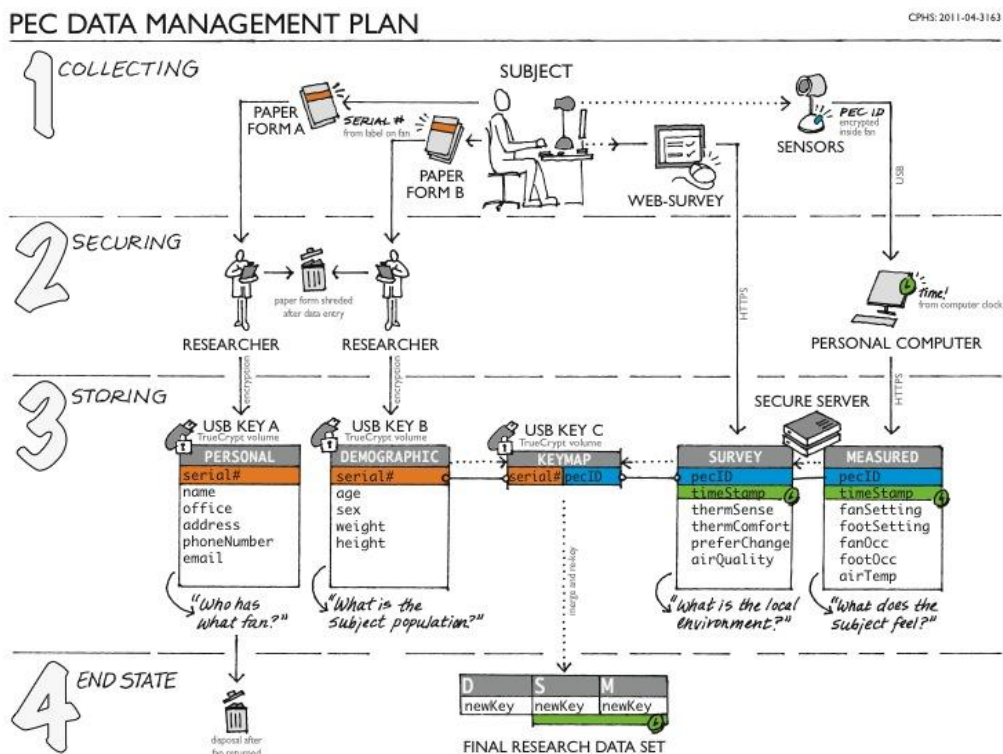



The right-hand side of the diagram, which deals with Survey and Measured data, is the important one for information technology. To collect the data for our research, the system incorporates sensors that automatically record the settings the subject chooses for the fan and footwarmer, the air temperature around the subject's desk and whether or not the workstation is occupied. A single record containing these five variables requires three bytes of data. The system collects one of these three-byte records every minute<sup>1</sup>. A software program on the subject's PC encrypts and forwards this information to our secure database via a secure internet connection. Additionally, every few days the subject is asked (by either a prompt on their computer or an email) to take a short online survey about thermal sensations and comfort.

### PECS Firmware:



The physical portion of the system consists of a small desktop fan for cooling, and an under-desk footwarmer for heating. These components are built around the [Arduino](#) open-source electronics prototyping platform. Each CBE PECS contains an Arduino microcontroller inside the fan unit, which receives inputs from sensors and the user interface, issues commands to control the fan and heating elements, and communicates with the subject's PC via a USB cable. The microcontroller is programmed using the Arduino Development Environment (based on [Processing](#)) in our lab before we deliver the PECS to a subject<sup>2</sup>. We do not anticipate updating the firmware on the devices after they are deployed into the field, however, if necessary, new code can be uploaded by connecting the PECS unit to a computer running the ADE.

Most of the microcontroller code has to do with the sensing and hardware control; however it also has three key functions in the data-management scheme. First, to allow the research team to analyze all the data from a given PECS, each unit has a unique identity code encrypted in its Electronically Erasable Programmable Read-Only Memory (EEPROM) prior to distribution. For security, this key is a random string of characters unrelated to the subject's identity, which allows us to query the database while protecting users' privacy. Second, the microcontroller filters some of the sensor data, such as correcting the temperature readings according to a calibration constant, and converting readings and control settings from analog voltages or floating point variables into more compact data types to save memory. Thirdly, the microcontroller ensures the integrity of the data it passes along by verification and buffering.

---

<sup>1</sup> Naturally this one-minute sampling rate can be adjusted, for example it may be set to five minutes in situations where buffering limits are a concern.

<sup>2</sup> The code is available for review if desired, please contact [littleFans@cbe.berkeley.edu](mailto:littleFans@cbe.berkeley.edu).

After each transmission, the microcontroller verifies the data transmission to the PC was complete. Additionally, the micro-controller stores a buffer of measured sensor data in memory, which it uses to handle any interruptions in the connection to the subject's Personal Computer. This data buffer can store at most 1007 bytes of data, or 335 three-byte records.

### PC-Client

Periodically, the PECS unit will transmit the compressed data to the subject's Personal Computer via USB connection. The PC will temporarily buffer data before transmitting it via a secure HTTPS Internet connection to the CBE webserver.

The PC communication client software on the subject's Personal Computer is written in [Python](#), and converted into a Windows executable or Mac application using py2exe or py2app respectively<sup>3</sup>, thus python need not be installed on the subject PC. The client program is designed to launch automatically on startup, run continuously in the background and require no user interaction. The client uses about 5 MB of memory and much less than 1% of processor resources. The installer for the client software can be downloaded from the CBE website at: [www.cbe.berkeley.edu/pecs](http://www.cbe.berkeley.edu/pecs).

When launched, the client surveys the available COM/serial ports to find the attached PECS and establish communication. The PC client immediately ascertains if the devices are correctly connected, which version of the firmware is loaded onto the Arduino, and the unique pecID for the attached PEC System. All of this data is stored in volatile memory until the client software closes, typically when the computer shuts down.<sup>4</sup> Once the initial connection is established, the PC client begins accepting and parsing the data stream from the microcontroller built into the PECS. The client software reflects each piece of data it receives back to the PECS to verify the transfer before the PECS will delete the record. The PECS hardware does not have an embedded real-time clock, so records transferred in real-time are associated with current system time by the PC client. The PC Client also provides the system time to the PECS during data reflection so that the PECS can record it with buffered data in case the PECS ever becomes disconnected from the PC. This allows buffered data to be provided to the PC with a valid timestamp.

Every four seconds, two threads in the PC client transmit available data (real-time and/or buffered) to the CBE server using HTTPS. With the overhead of HTTP+SSL, each record-sending request is about 1.5 KB in size. At a sampling/sending rate of one record per minute,

---

<sup>3</sup> The code is available for review if desired, please contact [littleFans@cbe.berkeley.edu](mailto:littleFans@cbe.berkeley.edu).

<sup>4</sup> Note that to protect subject privacy, the encrypted pecID cannot be decrypted at the PECS unit or on the PC client; the block of encrypted data is simply passed to PC client, held and then communicated through the secure internet connection to the server as described elsewhere.

each PECS adds about 205 bits per second to network. Assuming a 10Mbps connection to the public internet, each PECS user will utilize an average 0.002% of available bandwidth.

To create a secure channel across the (non-secure) public internet to either transmit measured data, or present the web survey, the PC client software and webserver make use of HyperText Transfer Protocol Secure (HTTPS), as used in many online payment systems. HTTPS is a combination of two technologies: the cryptographic protocol known as Transport Layer Security (TLS) creates a secure connection, inside of which conventional HTTP communication takes place. HTTP, the foundation of data communication on the web, is a widely-used protocol for request-response communications between a client and a server. Transport Layer Security uses asymmetric (or public-key) cryptography, in which the encryption key is divided between a public portion used to encrypt the data, and a secure, private portion that is needed to decrypt the data. This means the public portion of the key can be made widely available and need not be secured, while the private key resides safely on the server. When properly implemented with an adequate cryptographic algorithm, TLS is considered secure against man-in-the-middle and eavesdropping attacks because at most, an attacker can only know the fact that a connection is taking place between the two parties who are already known to him, and the IP addresses. This protocol makes use of the latest SHA-256 Secure Hash Algorithm, which was developed by the National Security Agency and published as a Federal Information Processing Standard (FIPS PUB 180-2). This is the standard for encryption used by Federal Agencies to protect sensitive unclassified government information. The certificate used for the TLS connection was created by Ryan Luecke, a computer scientist at CBE and is available for inspection via this webtool: <http://certlogik.com/sslchecker/cbedb.dynalias.com/> or by connecting directly to <https://cbedb.dynalias.com> and using your browser to inspect the certificate.

To handle any interruptions in the connection to the CBE server, the PC-client writes a buffer file in %TEMP% for Windows and in \$TMPDIR for Mac OS. The size of this buffer file is limited to 5MB. After the connection to the server is restored, the data stored in the buffer is transferred to the CBE server as described above. The data in the buffer is in compressed form, and not human readable. The PC client cleans-up this buffer after the transfer to the server is validated, preserving security and reducing storage requirements. Of course, as the buffer is stored in the user's directory it is secure from other possible users on that machine.

### Server

Once the data arrives at the server, it is decrypted and inserted into the database. In addition to the time stamp attached to the data when it is measured, the data stored in the research database is associated with a specific PEC Unit's ID code. Before distributing a PECS unit to the field, a unique pecID is encrypted using the AES algorithm described above and written to the Electrically Erasable Programmable Read Only Memory (EEPROM) inside the PEC device.

The server uses HTTPS to communicate with the PC client, and indirectly, the PECS. The server's hostname is currently cbedb.dynalias.com, and the server itself is physically located on Berkeley's Campus in California.

Also, the server does not retain the subject's IP address or other network information after the communication is finished and the secure link terminated. At no time is the IP address added to the research database.

### Survey

The survey is conducted online, so the subject simply visits a secure web-page hosted on the CBE web-server. To collect this data, the communication client software on the subject's PC will prompt the subject to take a survey by following a URL link. Clicking the link establishes a secure connection to the server using HTTPS, opens the survey webpage and automatically transfers the encrypted pecID through that secure connection. When the subject completes the survey and clicks "submit" the survey responses are immediately added to the database and keyed with the time and pecID. The server does not retain the subject's IP address or other network information after the communication is finished and the secure link terminated. At no time is the IP address added to the research database.

## NOTE ON THE TEXT

This document was typeset using  $\text{\LaTeX}$  in 12 point Palatino.

Designed by Hermann Zapf following World War Two, the original Palatino was released by Linotype for their composing machine in 1948. The face was subsequently cut in metal by August Rosenberger at D. Stempel AG typefoundry in Frankfurt in 1950 and later adapted to three other media (photo-type film, transfer sheets, digital glyphs) thereby becoming one of the most widely-used typefaces in the world. This serif typeface is based on the humanist letterforms of the Italian Renaissance, and named after the sixteenth-century master of calligraphy, Giambattista Palatino. The classical proportions, subtly adjusted by Zapf's penmanship, lend the typeface its characteristic flowing calligraphic grace. This design, along with the open-counters and careful contrast between thick and thin strokes make the face highly legible for text and display.

See <http://www.mindspring.com/fez/palatino/palfaq1.0.txt> for more.