

Lawrence Berkeley National Laboratory

Recent Work

Title

Operating Experience with the ALS Linac

Permalink

<https://escholarship.org/uc/item/8xn2g32q>

Authors

Selph, F.

Massoletti, D.

Publication Date

1992-05-01



Lawrence Berkeley Laboratory

UNIVERSITY OF CALIFORNIA

Accelerator & Fusion Research Division

Presented at the IEEE Particle Accelerator Conference,
San Francisco, CA, May 6-9, 1991, and to be
published in the Proceedings

Operating Experience with the ALS Linac

F. Selph and D. Massoletti

May 1991

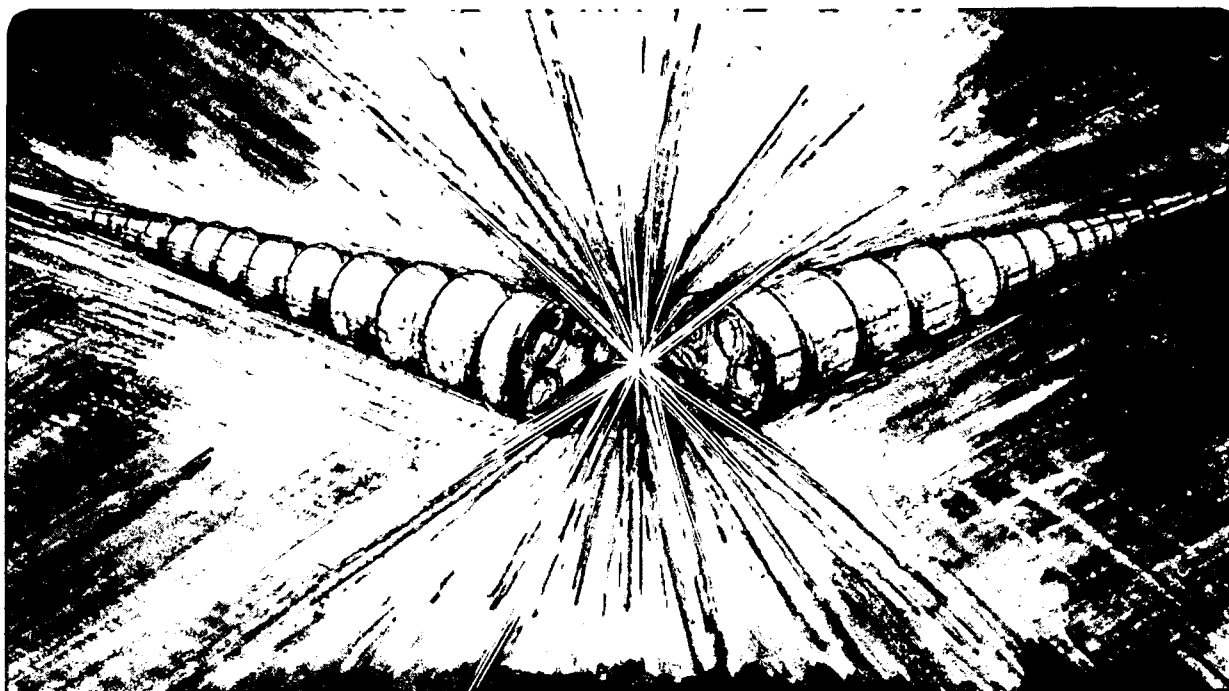

1 LOAN COPY 1
1 Circulates 1
1 for 4 weeks 1
1 Bldg. 50 Library.
Copy 2

LBL-29943

DISCLAIMER

This document was prepared as an account of work sponsored by the United States Government. While this document is believed to contain correct information, neither the United States Government nor any agency thereof, nor the Regents of the University of California, nor any of their employees, makes any warranty, express or implied, or assumes any legal responsibility for the accuracy, completeness, or usefulness of any information, apparatus, product, or process disclosed, or represents that its use would not infringe privately owned rights. Reference herein to any specific commercial product, process, or service by its trade name, trademark, manufacturer, or otherwise, does not necessarily constitute or imply its endorsement, recommendation, or favoring by the United States Government or any agency thereof, or the Regents of the University of California. The views and opinions of authors expressed herein do not necessarily state or reflect those of the United States Government or any agency thereof or the Regents of the University of California.

Operating Experience with the ALS Linac

F. Selph and D. Massoletti

Accelerator Fusion Research Division
Lawrence Berkeley Laboratory
University of California
Berkeley, CA 94720

May 1991

Presented at the Particle Accelerator Conference, 6-9 May 1991,
San Francisco, CA

This work was supported by the Director, Office of Energy Research, Office of Basic Energy Sciences, Material Sciences Division, U.S. Department of Energy, under Contract No. DE-ACO3-76SF00098.

Operating Experience with the ALS Linac

F. Selph and D. Massoletti
Lawrence Berkeley Laboratory
Berkeley, California 94720

INTRODUCTION

The linac injector for the Advanced Light Source (ALS) at LBL was recently put into operation. Energy is 50 MeV, frequency 3 GHz. The electron gun delivers up to 6 nC in a 3.0-ns bunch at 120 kV. A train of bunches is injected into a 1-Hz booster and accelerated to 1.5 GHz for storage ring injection. A magnetic analysis system is used for optimizing the linac. Measured beam properties from the gun and after acceleration in the linac are described. Fig. 1 shows the arrangement of major linac components, and Fig. 2 is a photograph of the completed linac.

Gun

Gun performance has proved to be adequate to meet specifications. The gun contains a dispenser-type cathode, 1 cm² in area. Emittance at 120 kV was measured, and found to be less than the specified $4 \times 10^{-5} \pi$ m. Normal operation for booster injection is one bunch at a 1-Hz rate, or a train of 12 bunches separated by 8 ns, also at a 1-Hz rate. The bunch width from the gun is about 3 ns FWHM. If after bunching and acceleration in the linac the energy spread is wider than the booster can accept (about 1%), some collimation at 50 MeV is done after a 40° bending magnet, where the dispersion is large.

Subharmonic Bunchers

On the basis of computer simulations it was concluded that an injection system for the linac incorporating two subharmonic bunchers would be most effective (1). The program PARMELA (2) was very useful in predicting performance. PARMELA includes longitudinal and transverse space charge effects, which are important for our bunch intensities of 2–6 nC. The engineering design (3) incorporates two subharmonic bunchers having frequencies of 125 and 500 MHz, respectively. Ideally, the bunches on reaching the first would span 90° in phase (2 ns), be compressed four times, and on reaching the second, again span 90° in phase. The gun pulse is wider than this ideal, but measurements show that the first subharmonic buncher does compress four times in phase. The second provides additional

compression, as evidenced by its effect of increased linac transmission, but pulse length after this buncher cannot be measured directly.

Linac and S-Band Buncher

The linac is made in two independently driven 25-MeV sections, each 2 m long (4). The rf frequency is 2.9979 GHz. Attached to the first section is a 10-cm section of disk-loaded waveguide, designed for a phase velocity of 0.75 c, known as the s-band buncher (5). This is driven by the same klystron as the first linac section, but is provided with independent control of amplitude and phase. Although the 50-MeV energy could be achieved by one accelerating section, the two independently driven sections achieve more flexibility in operation. One important purpose involves maintaining a small energy spread with a multibunch pulse. With a 150-ns pulse, the resulting beam loading of the linac will be compensated by phase-shifting of the linac sections (6).

Transport Line and Analysis System

A $\pm 40^\circ$ switching magnet is located about 5 m from the end of the linac (Fig. 3). The bend produces dispersion so that the energy spread of the beam delivered to the booster can be controlled by an adjustable collimator 1 m downstream from the magnet. A similar collimator is placed in the analysis line, where the dispersion is the same, so that the transmitted intensity can be read on the Faraday cup. The shielded Faraday cup also serves as a beam dump within the linac cave, which is useful for linac tuning while minimizing radiation levels outside the heavily shielded linac area. The intention is to transmit to the booster only the electrons that will be accelerated to 1.5 GeV.

Instrumentation

ALS instrumentation has been described in an internal report (7). All data used in operations is digitized (8) for display on high-resolution computer monitors, and selected data can be archived on magnetic or optical recording media. This was made

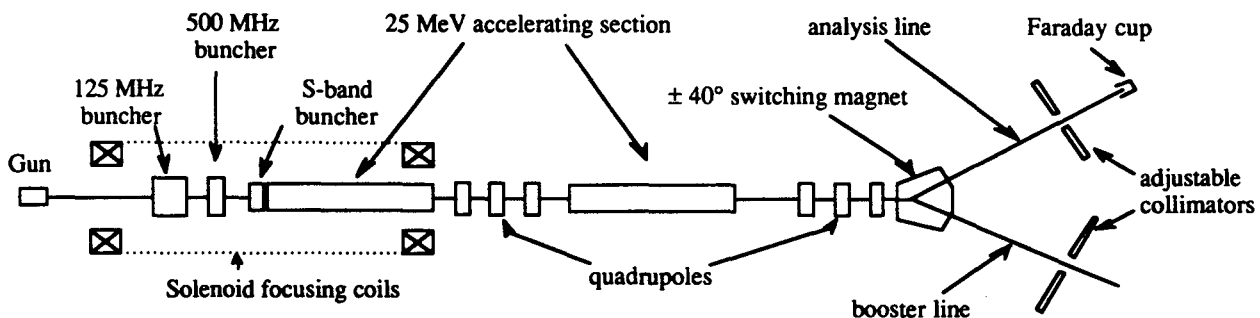

Major components of ALS 50 MeV Linac

Fig. 1.

feasible by recent advances in microprocessor and electronic instrument technology, which made the tools for accomplishing these tasks available at modest cost.

Scintillation screens mounted on remotely operated plungers are installed at a number of locations. A CCD TV camera is used to view the image of the beam profile. Although destructive, this device is very valuable as it is the only instrument that shows the beam shape. The image can be viewed directly on a TV monitor, but can also be digitized by a "frame-grabber" board in a microcomputer, and this data used for analysis.

Gun output is measured with a wall current monitor, a nondestructive pickup between the gun and the first subharmonic buncher. This device is also useful for measuring absolute bunch intensity and the time profile of bunches, and for seeing the number of bunches in the gun pulse.

A Faraday cup is used routinely in the analysis line for tuning. A deep aluminium cup is backed by a lead plug, and both are enclosed in a stainless steel shell mounted on a ceramic insulator. The shell provides the electrical connection, tapering down to a 50-ohm coupling to give a good frequency response. The purpose of using an aluminium cup is to reduce the neutron production. Additional lead shielding is provided to attenuate the gamma rays, so that less concrete is required to meet background requirements.

For nondestructive measurement of beam position two types of four-electrode capacitive pickups (BPMs) are used. Where space is at a premium, between gun and linac and between linac sections, electrodes are about 5 mm in diameter. In the transport to the booster (ltb line), the BPMs are striplines about 20 cm long and are used with steering magnets to keep the beam centered. Both types give x and y position to within 1 mm accuracy near the center of the vacuum chamber. The output of the electrodes can also be summed to give a measure of bunch intensity.

Horizontal collimators are located near a position of maximum dispersion in the booster transport line. The jaws are made of 0.5-in-thick tantalum and are remotely adjustable to provide

a gap from 0 to 60 mm. In use, the gap is positioned in the center of the vacuum chamber and the transmitted fraction is used. A monoenergetic beam would have a tight waist at the collimator—about 0.6 mm—so that energy spread is almost directly proportional to collimator width. A gap of 8.3 mm allows 1% energy spread to be transmitted, which is expected to be about the limit of booster acceptance. A set of vertical collimators allows cleaning up the vertical halo before transmitting beam to the booster. These collimators have not only the useful function of reducing booster losses (since with them it is likely that nearly all beam injected will be accelerated), thus reducing the radiation level; they also provide a cleaner beam for understanding beam optics in the ltb line.

An identical horizontal collimator assembly is placed in the analysis line. Using it, a narrow gap can be moved across the vacuum chamber so that a beam profile can be read with the Faraday cup. More commonly, the gap is positioned at the center of the vacuum chamber and the analysis magnet is scanned. A temperature-compensated Hall probe is installed in the analysis magnet, which gives a precise magnetic field level (hence a precise energy determination), as the current is varied.

Controls

This control system has been described in a previous paper (9). The hardware interfaces (DACs and ADCs) are contained on single-board computers called intelligent local controllers (ILCs). Each ILC is connected to one or more devices. The operator interface is a group of monitors, each driven by a personal computer. The displays are completely democratic—any available data can be shown on any display monitor. Also, since only a data link such as Ethernet is required in order to access the database, it is easy to allow other computers within the laboratory this access. The connection between the operator's computers and the ILC is another group of microprocessors. The ILCs are an LBL-designed board loaded with commercially available electronic components.

Most of the software used is available commercially. Among them are relational databases, spreadsheet programs, graphics programs, object-oriented languages, network programs, and standard PC operating systems (DOS, OS/2). So far we have found that relying on commercially available PC software has many advantages. Cost is modest, it is mostly bug-free, and is sophisticated enough to meet our needs. One computer acts as a file server and the central repository of programs used in the control system. The goal in system design was to provide a data refresh rate of 10 Hz, and so far this goal has been met. This is within human response times, thus the operator does not experience frustrating delays in the system response.

SUMMARY

Assembly of linac components was largely completed and commissioning begun in October 1990. The linac sections with their associated waveguides and loads were conditioned with rf power until a vacuum in the 10^{-8} -Torr range was achieved, before acceleration of electrons was attempted. This began in February 1991, and the first 50-MeV beam reached the Faraday cup in March. Optimization of the operation of bunchers and linac rf is continuing, but we have established that all systems work as expected. At present the intensity of beam delivered to the Faraday cup is about 0.3 nC per bunch, with 1.8% FWHM single bunch, and 4% multiple bunch energy spread.

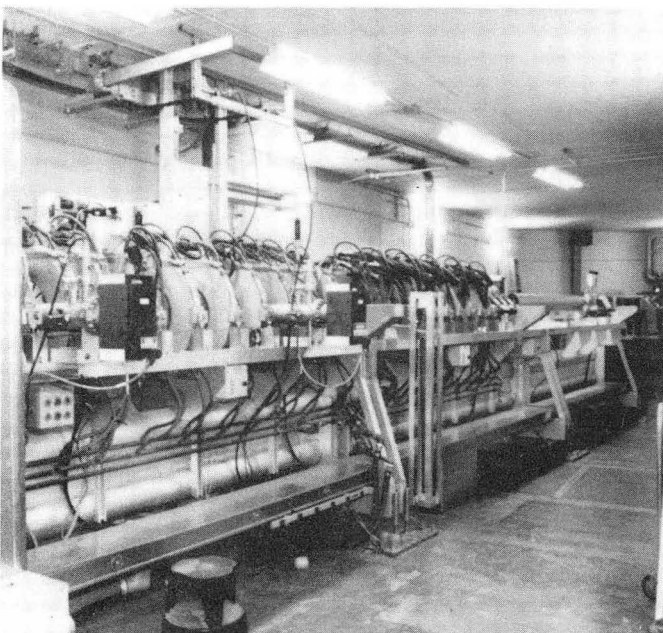

Fig. 2. The ALS linac, with the gun housing on the left. The gun-to-linac and first linac sections are surrounded by solenoid coils and supported on three rigid girders. The 3-GHz waveguide is visible at the top of the picture, and the switching magnet is at the extreme right. [CBB 900-9336]

REFERENCES

Linac conditioning to the 50-MeV operating level was accomplished after a cumulative run time of less than 70 hours, consisting of about 25 hours of rf systems testing and conditioning and about 40 hours of actual linac operation. To date there has been about 160 hours of linac commissioning. The original cathode is still in use, with a cumulative run time of about 300 hours. Operation of the linac is restricted to off-hours while the building and facilities are under construction, which slows down the commissioning process considerably.

To avoid vacuum contamination and a protracted conditioning period, UHV practices and techniques were employed for preparation and fitting during the assembly of the rf feeds and vacuum system. Particular attention was paid to the problems of moisture and particulate contamination in the building construction environment. The engineering of the rf systems paid particular attention to the goal of providing operational simplicity. Complete control and diagnostic capabilities for rf devices are provided through the computer system, although as a prudent measure, during this commissioning period a person is always stationed near the klystron power supplies to observe any unusual behavior.

ACKNOWLEDGEMENTS

This work was supported by the Director, Office of Energy Research, Office of Basic Energy Sciences, Material Sciences Division, U.S. Department of Energy, under Contract No. DE-AC03-76SF00098.

1. R.H. Miller, C.H. Kim, and F.B. Selph, "Design of a Bunching Septum for a High-Intensity Electron Linac," Proceedings of the 1988 European Particle Accelerator Conf., 863 (1988).
2. "Computer Codes for Particle Acceleration Design and Analysis," 2nd ed., 137 (1990).
3. C.C. Lo. et al., "Advanced Light Source Linac Subharmonic Buncher Cavities," Proc. of the 1989 Part. Accel. Conf., 89CH2669-0, 957 (1989).
4. B. Taylor, H. Lancaster, and H. Hoag, "Engineering Design of the Injector Linac for the Advanced Light Source (ALS)," Proc. of the 1988 Linear Accel. Conf., CEBAF Report 89-001, 565 (1989).
5. R.H. Miller, R.F. Koontz, D.D. Tang, "The SLAC Injector," IEEE Trans. Nucl. Sci., N.S. 12, No. 3, 804 (1965).
6. F. Selph, "Compensation of Beam Loading in the ALS Injector Linac," Proc. of the 1988 Linear Accel. Conf., CEBAF-Report 89-001, 580 (1989).
7. J. Hinkson, "ALS Injector Diagnostics," LSEE-098, Feb 1991.
8. M. Chin, J. Hinkson, S. Magyary, "Networking Remote Instrumentation for the Advanced Light Source," Proc. of the 1989 Part. Accel. Conf., 89CH2669-0, 1648 (1989).
9. S. Magyary et al., "Advanced Light Source Control System," Proc. of the 1989 Part. Accel. Conf., 89CH2669-0, 74-98 (1989).

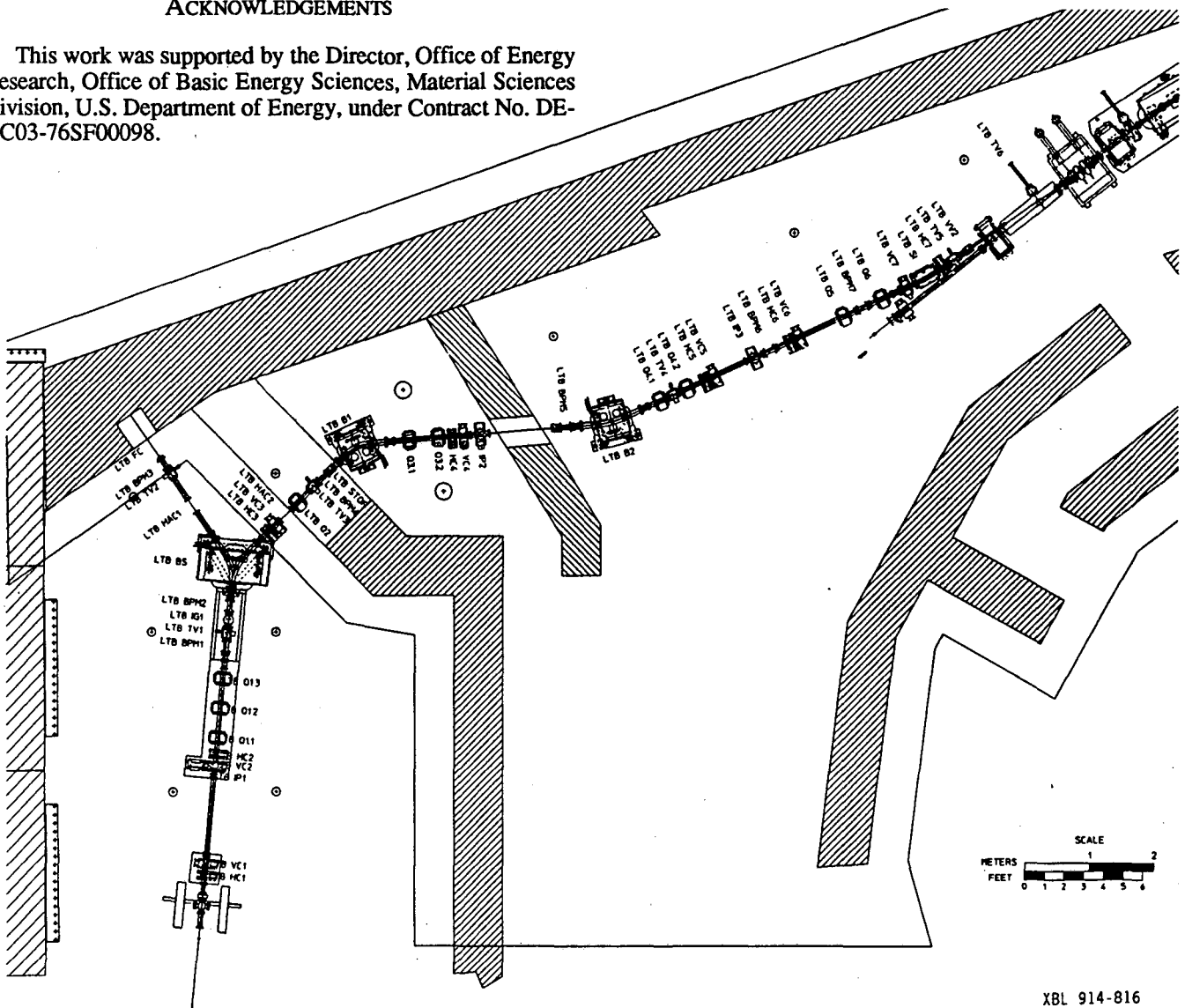

Fig. 3. Transport line from the linac to the booster.

XBL 914-816

LAWRENCE BERKELEY LABORATORY
UNIVERSITY OF CALIFORNIA
INFORMATION RESOURCES DEPARTMENT
BERKELEY, CALIFORNIA 94720