

# UC San Diego

## UC San Diego Electronic Theses and Dissertations

### Title

Design and analysis of an articulated spoke multi-modal robot and design and implementation of object manipulation features

### Permalink

<https://escholarship.org/uc/item/8xd1327r>

### Author

Sams, Benjamin Andrew

### Publication Date

2011

Peer reviewed|Thesis/dissertation

UNIVERSITY OF CALIFORNIA, SAN DIEGO

Design and Analysis of an Articulated Spoke Multi-Modal Robot

and

Design and Implementation of Object Manipulation Features

A thesis submitted in partial satisfaction of the requirements for the degree Master of  
Science

in

Engineering Sciences (Mechanical Engineering)

by

Benjamin Andrew Sams

Committee in charge:

Professor Thomas R. Bewley, Chair  
Professor Raymond A. de Callafon  
Professor Frank E. Talke

2011

Copyright

Benjamin Andrew Sams, 2011

All rights reserved.

The thesis of Benjamin Andrew Sams is approved and it is acceptable in quality and form for publication on microfilm and electronically:

---

---

---

Chair

University of California, San Diego

2011

## Table of Contents

Signature Page.....	iii
Table of Contents .....	iv
List of Abbreviations.....	viii
List of Symbols .....	ix
List of Figures .....	x
List of Graphs.....	xi
List of Tables.....	xii
Abstract of the Thesis.....	xiii
<b>PART 1: Walk &amp; Roller - The Articulated Spoke Multi-Modal Robot.....</b>	<b>1</b>
Chapter 1 Introduction to the Walk & Roller .....	1
1.1 Background .....	1
1.1.1 Design Inspirations .....	4
1.1.2 Utilizing Preexisting Technology .....	5
1.1.3 Comparison to Existing Robots/Vehicles .....	5
1.2 Review of Related Research .....	6
1.2.1 Rolling on Rimless Wheels.....	7
1.2.2 Rolling by Wheel Deformation.....	8
1.2.3 Climbing Robots/Vehicles.....	9
1.3 Novel Research Elements.....	10
1.3.1 Novel Mechanisms.....	10
1.3.2 Novel Controls.....	11
1.3.2 Novel Construction.....	13
Chapter 2 Project Goals and Trajectory .....	14
2.1 Desired Modes of Locomotion.....	14
2.1.1 Tumbleweed Mode .....	15
2.1.2 Walkover Mode .....	16
2.1.3 Platform Climbing Mode .....	17
2.1.4 Narrow Passage Mode .....	18
2.1.5 Shaft Ascension Mode .....	19
2.1.6 Transition Between Vertical and Horizontal Travel.....	20
2.2 Design Problems and Solutions .....	21
2.2.1 Specifications That Are Coupled.....	23
2.2.2 Physical Limitations.....	23
2.2.3 Scale and Design Compromises.....	24
2.2.4 Peripheral Design Constraints.....	24
Chapter 3 Theory.....	25
3.1 Geometry.....	25
3.1.1 Angle and Segment Definitions.....	26
3.1.2 Inverse Kinematics.....	27
3.1.3 Forward Kinematics.....	28

3.1.4	Reverse Kinematics .....	29
3.1.5	Reach, Pace and Natural Gaits.....	32
3.2	Static and Quasi-static Modes.....	34
3.2.1	Stable Modes.....	34
3.2.2	Unstable Modes .....	34
3.2.3	Minimum Torques Required to Facilitate the Desired Modes.....	35
3.3	Dynamic Modes .....	39
3.3.1	Equations of Motion .....	40
3.3.2	Dynamic Center of Gravity.....	40
3.3.3	Dynamic Moment of Inertia.....	40
3.3.4	Stable Modes.....	41
3.3.5	Unstable Modes .....	41
3.3.6	Speed and Torque Requirements for Dynamic Stability .....	41
3.4	Controls.....	42
3.4.1	Controllability and Observability .....	42
3.4.2	Successive Loop Closure .....	42
3.4.3	Open-Loop Path Planning.....	43
3.4.4	Closed-Loop Path Planning .....	43
3.4.5	Stabilization of Unstable Modes.....	44
3.4.6	Active Suspension.....	44
3.4.7	Closed-Loop Spoke Tip (End-Effector) Positioning.....	45
Chapter 4	Experimentation.....	46
4.1	Computer Aided Design/Finite Element Analysis.....	46
4.2	Previous Versions.....	46
4.2.1	Component Selection Process.....	47
4.2.2	Worm Drive Testing Apparatus.....	47
4.2.3	One Hub, One Spoke and Many MXL Timing Belt Options.....	48
4.2.4	A Sensing Tip Design That Increased the Degrees of Freedom.....	50
4.3	Fabrication of a Working Prototype.....	51
4.3.1	Equipment Load Out.....	51
4.3.2	Structural Considerations.....	53
4.3.3	Material Selection .....	55
4.3.4	Process Selection .....	55
4.3.5	Tolerances.....	56
4.4	Programming.....	56
4.4.1	Division of Labor.....	57
4.4.2	Communication of Data Signals.....	57
4.4.3	Feedback .....	58
4.4.4	Tolerances.....	58
4.5	Power.....	59
4.6	Operation.....	59
4.6.1	User Controls .....	59
4.6.2	Automation .....	60
4.7	Modeling and Simulation.....	60

4.7.1	Activation and Contact .....	61
4.7.2	Rising to a Neutral Position .....	61
4.7.3	2D Motion Cases.....	62
4.7.4	3D Motion Cases.....	62
Chapter 5	Results.....	64
5.1	Things That Do and Do Not Work.....	64
5.2	Compare Simulation to Experiment.....	65
5.2.1	Geometric Analysis For Various Modes.....	65
5.2.2	Predicting Forces and Required Torques .....	66
5.2.3	Accuracy of Model .....	66
5.2.4	Correctness of Assumptions .....	67
5.3	Effectiveness of Design.....	67
5.4	Effectiveness of Controls .....	67
5.5	Effectiveness of Hardware .....	68
5.6	Effectiveness of Software.....	68
Chapter 6	Discussion.....	70
6.1	Current progress Along Project Trajectory .....	70
6.2	Performance of the Locomotive Modes .....	70
6.3	Advantages and Disadvantages of the Current Design .....	71
6.3.1	Dimensions Selected Without Any Specific Constraints.....	71
6.3.2	Unanticipated Complications.....	71
6.4	Unused Design Ideas.....	72
6.4.1	Worm Gear Transmission.....	72
6.4.2	Servo Drive .....	73
6.4.3	Central Power.....	74
6.4.4	Soft Pot Position Sensors .....	74
6.4.5	Absolute Digital Encoders .....	75
6.4.6	Strain Gauges .....	76
6.4.7	Force Sensors .....	76
6.4.8	Baby Orangutans.....	76
6.4.9	MXL Size Timing Belts.....	77
6.4.10	Spinners.....	77
6.4.11	Slip Rings.....	78
6.4.11	Vacuum Cups.....	78
6.5	Untested Claims .....	79
6.6	Suggestions for Future Work .....	79
PART 2:	iFling - The Two-Wheeled Ball Pickup, Storage and Flinging RC Toy.....	81
Chapter 7	Mechanical Design of the iFling.....	81
7.1	Introduction .....	81
7.1.1	Project History .....	82
7.1.2	Project Goals.....	82
7.1.3	Problems to Address .....	82

7.2	Design Constraints .....	82
7.2.1	Vertical Balance Mode .....	83
7.2.2	Rover Mode .....	83
7.2.3	Flinging Mode.....	84
7.2.4	Compromises Between the Three Modes .....	84
7.3	Theoretical Considerations.....	84
7.4	Design of Mechanisms.....	85
7.4.1	Ball Pickup.....	85
7.4.2	Ball Storage.....	85
7.4.3	Ball Release .....	86
7.5	Development and Implementation .....	86
7.6	Conclusion.....	87
	References .....	89



## List of Abbreviations

#D	(number of) Dimensions or (number)-Dimensional
ADC	Analog to Digital Converter
AVR	This is a name, not an abbreviation
CAD	Computer Aided Design
CCW	Counter-Clockwise (or Anti-Clockwise)
CG	Center of Gravity
CM	Center of Mass
CNC	Computer Numerical Control (equipment automation)
COTS	Commercial Off The Shelf (referring to mass produced inexpensive components)
CW	Clockwise
DC	Direct Current
DOF	Degrees of Freedom
FEA	Finite Element Analysis
IC	Integrated Circuit
PTFE	polytetrafluoroethylene (Teflon)
W&R	Walk & Roller

## List of Symbols

### Geometry

- $H_a$  Absolute hub rotation measured CCW from positive X-axis
- $P_a$  Relative rotation of Pivot's  $0^\circ$  Axis measured CCW from  $H_a$
- $\alpha$  Angle at the base of the isosceles triangle formed by the spoke
- $\beta$  Central angle of the isosceles triangle formed by the spoke
- $\rho$  Absolute angle of the isosceles triangle's base measured CCW from positive X-axis
- $\theta$  Relative rotation of the upper segment measured CCW from the Pivot's  $0^\circ$  Axis
- $\varphi$  Relative rotation of the lower segment measured CCW from the upper segment

### Kinematics

- $A$  Angle between pivot's  $0^\circ$  axis and a line from the spoke tip to the pivot joint
- $B$  Angle between lines from the spoke tip to the hub's center and pivot joint
- $C$  Angle between pivot's  $0^\circ$  axis and a line from the spoke tip to the hub's center
- $a$  Length of side opposite angle 'A'
- $b$  Length of side opposite angle 'B'
- $c$  Length of side opposite angle 'C'
- $H$  Angles formed between lines from adjacent spoke tips to the hub's center
- $h$  Distance between support platform and the hub's center
- $f$  Distances between spoke tips in contact and the hub's center

### Statics

- $F$  Orthogonal sum of force vector components
- $M$  Net moments about a point

## List of Figures

Figure 1.1: Views of the Walk & Roller from (a) an isometric perspective and onto (b) sagittal and (c) coronal planes.....	2
Figure 1.3: Circle (dashed arc) described by the spoke tips. ....	4
Figure 2.1: Three of the neutral positions. (a) and (b) are stages of the Tumbleweed mode and (c) is a stage of the Walkover mode.....	15
Figure 2.2: A 100° rotation of the Tumbleweed mode.....	16
Figure 2.3: A 100° rotation of the Walkover mode.....	17
Figure 2.4: Platform Climbing mode.....	18
Figure 2.5: Narrow Passage mode.....	19
Figure 2.6: Shaft Ascension mode.....	20
Figure 3.1: Geometry and Notation of a Single Hub.....	26
Figure 3.2: Notation of mathematic triangles used for reverse kinematics.....	30
Figure 3.3: Forces and moments of a load carrying spoke on a horizontal surface.....	36
Figure 3.4: Forces and moments of a load carrying spoke against a vertical surface.....	37
Figure 4.1: Single hub complete with three spokes and low-friction pads on the base...	49
Figure 4.2: This lower segment construction includes a contact sensing spoke tip. (b), (d) and (f) show the positions of slide potentiometers' wiper for the tip configurations of (c), (e) and (g), respectively.....	50
Figure 4.3: These components are used to drive the revolute joints, (a) 3mm motor output shaft, (b) 3/16" pulley shaft and (c) 5/16" pulley shaft. The (d) 4mm rotary sensor shaft drives the through-hole potentiometer wiper.....	53
Figure 6.1: Worm gear set. Worm (right) drives worm gear (left).....	72

## List of Graphs

Graph 4.1: Performance specifications of the Maxon 111694 geared motor .....	52
Graph 4.2: Optimization of the flats on structural rods. ....	54

## List of Tables

Table 3.1: Maximum joint torques required for the current prototype design.....	39
Table 4.1: Worm gear combinations tested .....	48
Table 4.2: MXL timing belt combinations tested. Values are Number of Teeth.....	49

Abstract of the Thesis

Design and Analysis of an Articulated Spoke Multi-Modal Robot

and

Design and Implementation of Object Manipulation Features

By

Benjamin Andrew Sams

Master of Science in Engineering Sciences (Mechanical Engineering)

University of California San Diego, 2011

Professor Thomas R. Bewley, Chair

This research encompasses the development of two mobile robots. Both of the robots feature relatively large coaxial wheels on either side of a chassis for locomotion. The first has rimless wheels formed by articulated spokes used to relocate the center of gravity and modify the support structure. The second uses the stabilization of a boom extended vertically for travel.

Part 1 considers the locomotion of the actuated spoke rolling/walking/climbing robot. This novel platform provides agility for a robot capable of rolling like a wheel

with a varying radius, climbing over obstacles, shimmying within a vertical shaft and creeping at a very compact height. The research focuses on determining the dynamics for a specific design, developing semi-autonomous motion planning and utilizing feedback control for end-effector positioning and active suspension. The experimental portion focuses on sensor and actuator implementation, motion planning of varied locomotion modes and feedback control performed by an on-board microprocessor.

Part 2 considers the design of three novel ping pong ball handling features for an existing rolling and ball flinging robot. Previously, the robot was able to throw balls that were manually loaded. This research in mechanical design yielded greater autonomous capabilities by adding ball-pickup, storage and release mechanisms.

## **PART 1: Walk & Roller - The Articulated Spoke Multi-Modal Robot**

### Chapter 1 Introduction to the Walk & Roller

#### 1.1 Background

Most vehicles operate with a single locomotive strategy. Whether the design uses wheels, treaded tracks or legs, this specialization determines the type of terrain that is suitable. These vehicles may operate on limited slopes or surface roughness. Some vehicles capable of traversing difficult terrain use a combination of these choices; articulated or multiple independent track sets or wheels attached to actuated booms for greater travel ranges. The Walk & Roller demonstrates a less specialized structure that may be capable performing in a greater variety of environments. It will walk on uneven ground, roll like a wheel with a varying radius, climb over obstacles, shimmy within a vertical shaft and creep at a very compact height.

The Walk & Roller's locomotion process utilizes a set of three articulated spokes connected to each of the two co-axial hubs that roll like wheels without having tangible rims. At low speeds, the robot maintains 2-dimensional quasi-static stability by providing support on either side of the center of gravity. The third dimension is stabilized by the opposite hub and spoke set. The rolling is performed when two of the three articulated spokes provide support while the third rotates to a new position. By having two coaxial hubs capable of independent rotation, the Walk & Roller may turn in place similar to a track vehicle without skidding.



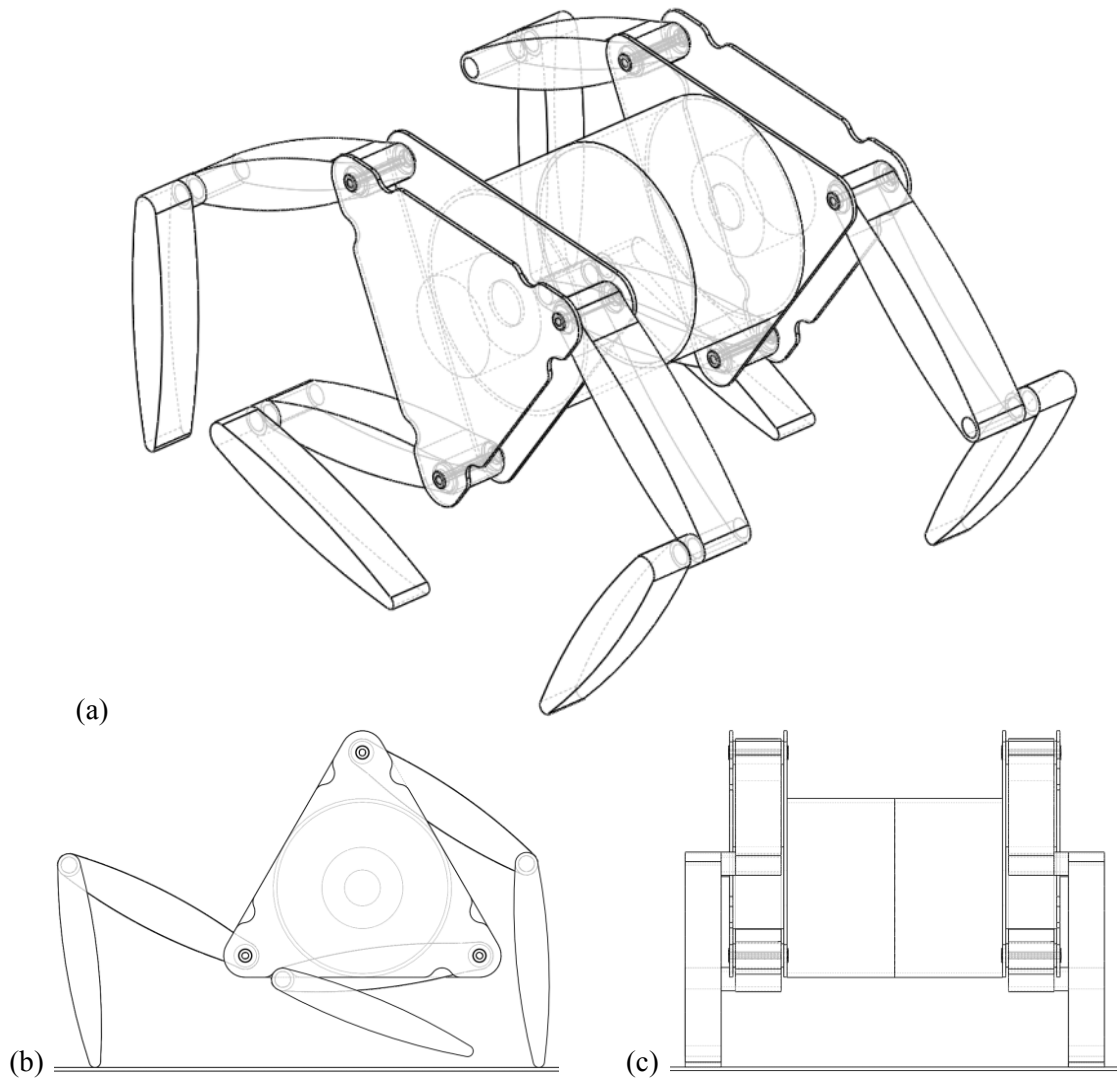

Figure 1.1: Views of the Walk & Roller from (a) an isometric perspective and onto (b) sagittal and (c) coronal planes.

Figure 1.1 shows the current design with both hubs in equivalent configurations. The coronal view reveals the planar relationship of the hubs and spoke segments. All upper and lower segments of a single hub share a common plane, respectively, and cannot cross paths. The upper spoke segments may nest in the hub compartment nearly

flush with the hubs' edges. The lower segment may rotate freely past the upper segments and the hub. The motors, electronics and power supply are located in the central cylindrical body.

The Walk & Roller benefits from symmetry and does not have a forward or reverse direction bias. Unlike most other vehicles, the center of gravity can be shifted anywhere between the supports and to a limited degree, outside of the supports. The locomotion is performed by shifting the center of gravity away from a current support region onto a new support region that may be continuously replaced. This process works for both stable (i.e. center of gravity is between multiple supports) or unstable (i.e. center of gravity is above a single support) modes. It may also work for high-speed rolling when “falling” due to gravity is compensated for by an upward force from the trailing spoke wherein the moment produces a translational acceleration.

### 1.1.1 Design Inspirations

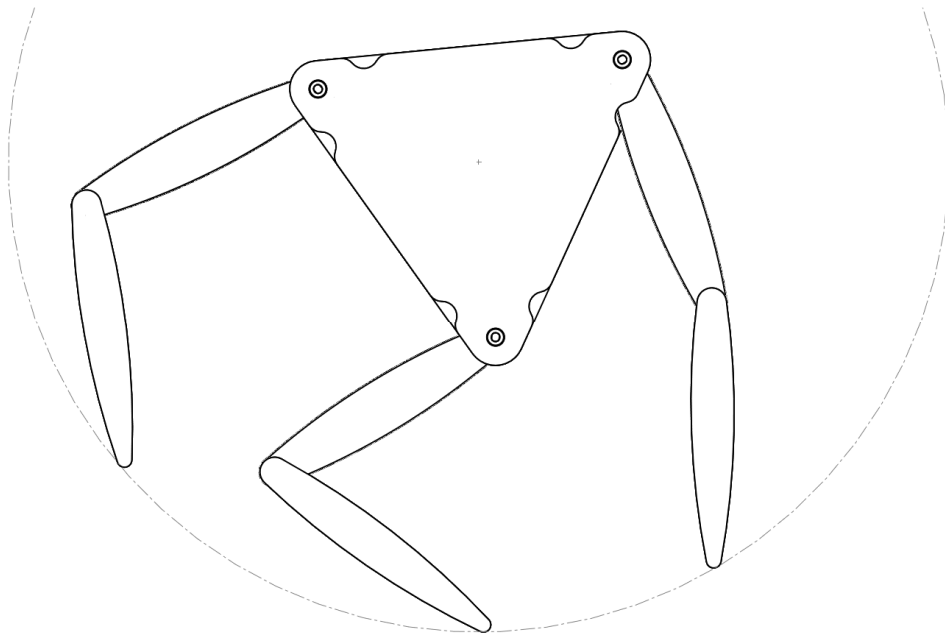

Figure 1.3: Circle (dashed arc) described by the spoke tips.

The primary inspiration came from considering an end effector positioning problem in which three independent points could be used to define a circle, see Figure 1.3. A robotic arm having two degrees of freedom with equal length segments can place the end effector in a wide sweeping area. Each spoke of the Walk & Roller behaves like an independent robotic arm. The “bases” of the spokes are equally spaced around a central hub to produce radial symmetry.

The location of the three spoke tips may describe any circle having a radius up to the distance between the hub’s center and the spoke tips. Correct timing and placement of the spoke tips could reproduce the rolling characteristics of a wheel without actually having a rim.

### 1.1.2 Utilizing Preexisting Technology

The research performed on this project represents the development of a novel arrangement of basic robotic elements. However, the composition and application of these existing technologies introduce new challenges in design. The spokes resemble independent two degree of freedom robotic arms having simple revolute joints for planar movement. The hub functions as a base to support the spokes. The hub may resemble an industrial turret manipulator wherein the bases of the spokes are maintained at fixed distances and orientations from the others. For mobility however, the hub is not fixed to a stationary platform by a fourth (normal to hub rotation) support. The body, which houses the motors, electronics and power supply is split in the middle to allow independent rotation of the hubs. The body may resemble any number of compact circular housings.

### 1.1.3 Comparison to Existing Robots/Vehicles

The performance of each mode is not expected to compete with the specialized counterpart, but rather offer some competent handling in each of the respective terrain types. The Walk & Roller will not move as fast as a wheeled vehicle on a smooth terrain, but it will be able to climb over objects that would otherwise block a wheel of the same size. This is possible because it can walk like a legged vehicle. Since the spokes feature radial symmetry, a relocated support will move from a trailing to a leading position without affecting the other supports. Lacking the need for reciprocating support placement, the Walk & Roller behaves more like a track vehicle having a variable length tread than like a traditional multi-limbed walker. Unlike a track vehicle with a fixed

tread length, the Walk & Roller can place the supports at any convenient location or orientation.

There are several vehicles featuring adjustable ride height or ground clearance. The Walk & Roller will be able to adjust the ride height to suit the terrain, pace or preferred gait. From the lowest to the tallest form, it may still move without rotating the hub to maintain a compact form or rise to a full length spoke extension. The height of each hub may be controlled independently for banked surfaces or turning as a cone would roll over a smooth surface.

Operation of the Walk & Roller consists of specifying the desired mode of travel and relative hub movements. The spoke movement and tip placement are controlled by the microprocessor to suit the terrain and geometric needs. The Walk & Roller will maintain a smooth trajectory for the hub's center by estimating the terrain and configuring a preferred geometry. In addition to terrain estimation, force vectors on the spokes will be measured to provide a fully active suspension.

## 1.2 Review of Related Research

Since the Walk & Roller is composed of mature technologies, it stands to reason that there exists a wealth of documentation for reference. However, the novel architecture of the Walk & Roller limits the relevancy of previous design and implementation solutions. On the one hand, the Walk & Roller is not assumed to be an effective vehicle for carrying payload or other useful applications. Without presenting a practical purpose, there is likely to be limited interest in the pursuit of similar designs.

On the other hand, the Walk & Roller may provide insight into interesting functionality and inspiration to find applications.

### 1.2.1 Rolling on Rimless Wheels

These robots feature wheels that can provide only discrete contact with the ground. The IMPASS [3] uses a single axle to drive two parallel rimless wheels made of three beams passing through the axis to produce six spokes of adjustable length. Their research provides a solid reference for gait/topology analysis, motion planning and locomotion modes similar to the Walk & Roller. The IMPASS is capable of a diverse set of gait types and independent "wheel" radii for turning like a cone would roll on a flat surface. The Whegs robot [17] features 6 wheels having 3 or 4 fixed spokes and no continuous rim. Whegs move like a 6 wheel drive vehicle with limited four wheel steering. However, the wheel design deemphasizes frictional traction and instead uses a rigid lever arm to lift the chassis above obstacles.

The three most notable features of the IMPASS, that are not found on the Walk & Roller, are the fixed spoke lengths, use of a tail boom for balance and a single drive axle that rotates both "wheels" in unison. The IMPASS utilizes fixed length beams for spokes which are displaced to alter the effective wheel radius (i.e. distance between the spoke tip in contact with the ground and axle). The displacement results in an equal change of tip to axle distance on the opposite side. Therefore, the IMPASS is limited to travel within passages that are taller than a spoke beam is long. Except when rotating the body about the axle, the center of gravity's location is not adjustable. The body, or boom, provides a third distant support for climbing tall platforms and some locomotion modes. The wheels

of the IMPASS rotate in phase and turning is accomplished strictly by a difference in lengths between parallel support spokes.

The Whegs are designed with the ability to climb obstacles and platforms that are taller than the wheel radius by leveraging the edge of the rigid spokes on the higher surface. The articulated body further improves reach and allows the center of gravity to be shifted. Wheel rotation is actuated by a single motor, but the spokes are not movable. The discrete contact of the spokes result in a jarring motion to the chassis that is smoothed by the other wheels being in alternative contact phases.

### 1.2.2 Rolling by Wheel Deformation

This class of robots resemble a continuous loop of segments that nearly form a regular polygon when in a neutral position. The locomotion is initiated by extending the center of gravity away from the point of support and falling over. The distance between the center of gravity and support creates a couple that imparts an angular acceleration. The locomotion is maintained by a continuous deformation of the loop to keep the center of gravity extended away from the support in the direction of travel. The SuperBot [2] and the ckBot [5] are two examples of this approach to travel.

The ckBot Is made of many identical segments with limited joint rotation. Their research provides a resource for the analysis of statically and dynamically stable rolling states for deformed wheels. The SuperBot features fewer segments, but each segment has additional actuated joints. The extra degrees of freedom allow the SuperBot to perform a self-righting sequence after falling over. Both robot designs have narrow track widths and suffer from out of plane stability. Neither has a mechanism to perform turns.

### 1.2.3 Climbing Robots/Vehicles

There are two categories of climbing robots discussed here, the first relates to the current Walk & Roller design while the second may inspire the implementation of future functionality. The categories may also be divided by strategies for climbing within a shaft, tube or pipe and that of free climbing. Free climbing is limited to travel where the center of gravity is not between the supports but rather stability relies on gripping objects in the environment.

Werner Neubauer's Spider-Like Robot [7] is designed to travel within a pipe of diverse dimensions and complexity. Four, six and eight leg versions are tested. The legs are equally divided into pairs located on parallel and opposite sides of the chassis. The joints maintain a planar relationship with the chassis and all other segments. The articulated legs offer great flexibility and gait adaptation to varied pipe conditions. The research provides an inspired description of reactive and reflexive control by implementing response sequences to unplanned collisions or obstacles. The simulation work demonstrates minimum requirements for successful climbing for robots with various numbers of legs.

The Tube Climbing Machine [6] features eight legs symmetrically distributed in two radial sets at either end of a long slender chassis. The legs are limited to reciprocating movements only, because the central hub does not rotate. The Tube Climbing Machine may have a similar topography to the Walk & Roller, but the dissimilar revolute joint orientations prevent the possibility of comparable configurations or locomotion modes. Their research provides reference to similar controls design considerations and desired sensor information.



The TankBot [19], a compact, low-profile track vehicle utilizing sticky treads demonstrates the capability to transition between orthogonal surfaces. The adhesion and elasticity of the treads allow TankBot to overcome steps even during vertical or overhead travel. The Mini-Whegs [18], is similar to the previously mentioned Whegs, but it is smaller and lighter. The Mini-Whegs uses adhesive pads at the end of each spoke. Both of these robots require a specific smooth surface to operate.

The LEMUR [16], is another kind of free climbing robot based on object gripping and intelligent path planning. The LEMUR has a sophisticated set of sensors to evaluate the next necessary move as well as consider potential future moves so as to choose a path that does not end. This research provides reference for the implementation of terrain estimation schemes. Their terrain estimation utilized both visual and tactile sensors to identify objects for holding and obstacles to avoid.

### 1.3 Novel Research Elements

The purpose of the Walk & Roller project is a proof of concept evaluation of the functionality and performance of this unconventional design. Therefore, it is desirable to fully explore each of the new elements.

#### 1.3.1 Novel Mechanisms

The Walk & Roller hosts many novel mechanisms for structure, locomotion and sensing. The design is inspired by notions of minimalism. The hub features only three spokes. Any additional spokes may produce a stronger overall robot, smoother

locomotion and extended capabilities. However, the three spoke tips are sufficient for defining the circle on which the hub may roll.

The spokes are made from two segments. Additional segments would increase the reach and potential for more complex modes. One actuated segment (i.e. a single rigid segment and a one degree of freedom revolute joint pair) would provide a simpler design, but would severely inhibit the achievement of desired modes and passage options. Since the spokes are articulated, the robot may better control the location of the center of gravity and neither a “tail” nor a “boom” is necessary for balance or motion.

Having the spoke segments nested between structural plates improves the strength and durability of the robot. However, having the segments inside another structure limits the rotation. The lower spoke segment is cantilevered such that it may pass by the hub and upper segment for a full 360° without collision. This cantilever design also allows for more compact “folding up.” Since the design is highly collapsible, the robot may move through narrow passages. With spoke segments capable of full rotation, walking motions may utilize rotational or reciprocal tip placement.

The sensors used for feedback control are chosen to avoid mechanical complexity or the creation of additional degrees of freedom in the design. The structures that manipulate the sensors are designed for negligible deflections and to allow unrestricted motions or control of the locomotion components.

### 1.3.2 Novel Controls

The Walk & Roller is designed to operate on a variety of terrain types while maintaining a smooth trajectory. This imposes several major control challenges,

especially for a small on-board microprocessor. The principle challenge is specifying the intermediate joint angular velocities when only the initial and final geometries are known.

In terms of active suspension on vehicles, the popular discussion pertains to stabilization of an end-effector from disturbances at the base of a boom or stabilizing a chassis from disturbances of the terrain. The chassis stabilization tends to be semi-active since it is impractical to rely entirely on actuators for suspension. The frontier of active suspension that is to be explored by this research is a hybridization of the other two concepts without the use of passive components. The spokes are actuated and perform the suspension, but live-tuning will depend on load distribution and hub rotation. The on-board microprocessor will be responsible for real time suspension tuning to suit the terrain and desired gait.

Climbing robots are usually highly specialized. The approach to climbing depends on the size, shape, aspect ratio and gripping technology employed. The universal concern is maintaining an equilibrium between the supports and the center of gravity. In many cases, the climbing robots are designed to ascend a single surface either with some roughness for gripping or some slickness for suction, adhesion or Van der Waals attraction. The Walk & Roller is constrained to operate in a shaft having two parallel surfaces within a range of distances apart and a minimum coefficient of friction. The controls and motion planning will have to maintain specific geometries and forces for traction. Additionally, the autonomous transitional sequences between horizontal and vertical travel will require significant controller robustness.

### 1.3.2 Novel Construction

The Walk & Roller features an assortment of design challenges for multi-purpose components that are both structural and compact. The spoke segments must resist bending or twisting and allow passage and movement of electrical and mechanical components. Due to the multi-functional requirements of the design, every structural component must be designed to suit a variety of performance specifications. For example, the middle joint requires a cantilevered shaft to support the lower segment that can pass signal and power circuits as well as rotate both a slip ring stack and a rotary sensor. To further complicate the design, the middle joint shaft must be supported by two separated bearing surfaces and it must be removable to facilitate repairs or modifications.

## Chapter 2 Project Goals and Trajectory

The goal of the Walk & Roller project is to develop a remotely operated semi-autonomous vehicle capable of moving in all of the modes described in this chapter. The Walk & Roller is not expected to perform practical or useful purposes at this time. The expectations are to determine the feasibility and extract physical insight from a special case of this previously undocumented robot design. The following modes will be developed in simulation and tested in experimentation.

### 2.1 Desired Modes of Locomotion

The Walk & Roller presents a versatile platform for different locomotion modes as well as some environment manipulation capabilities. The complete vehicle will have two parallel hubs capable of moving in unison to travel in a straight path, or at different rates for turning or obstacle avoidance. The following mode descriptions consider one hub, but may be applied to both.

Operation of the Walk & Roller begins with choosing one of the following modes and specifying the relative translation vector. The hubs and spokes will move according to a predetermined set of sequences that are specific to the chosen mode. The vehicle will autonomously determine the correct sequence and calculate support geometry to suit the terrain. Each time a new mode is chosen, the Walk & Roller will attempt to reset the spoke configuration to a neutral position. The neutral positions provide a cross compatible configuration for significantly different mode sequences.

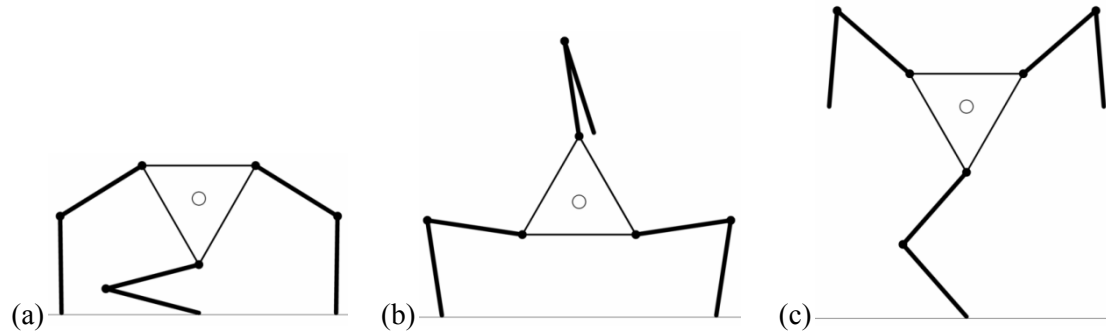

Figure 2.1: Three of the neutral positions. (a) and (b) are stages of the Tumbleweed mode and (c) is a stage of the Walkover mode.

Figure 2.1 shows three neutral positions in which there is no directional bias. The center of gravity is centered above the support region. Figure 2.1(b) shows the top spoke kinked for clarity. To be strictly neutral, both segments would be vertical and overlapping.

The sequences in figures of modes, 2.2 through 2.6, are displayed like cartoon panels, showing motion from left to right then top to bottom. The stage following the final panel would resemble the first stage with only slight differences such as a reflection. The circle approximates the center of gravity. For this demonstration, when rotating, the hub is moving to the right at a rate of 0.060" per degree or 23.580" per revolution. When creeping, the hub moves 8.00" and when ascending, the hub rises 10.00" total.

### 2.1.1 Tumbleweed Mode

Figure 2.2 shows the quasi-static rolling mode in which two spokes are in contact with the ground at any given time and the center of gravity is located somewhere in between the spoke tips. The third spoke is free to move into a position that produces an

adjacent support region. The Walk & Roller benefits from the radial symmetry of three equal spokes, so the rolling sequence repeats every  $120^\circ$  of hub rotation.

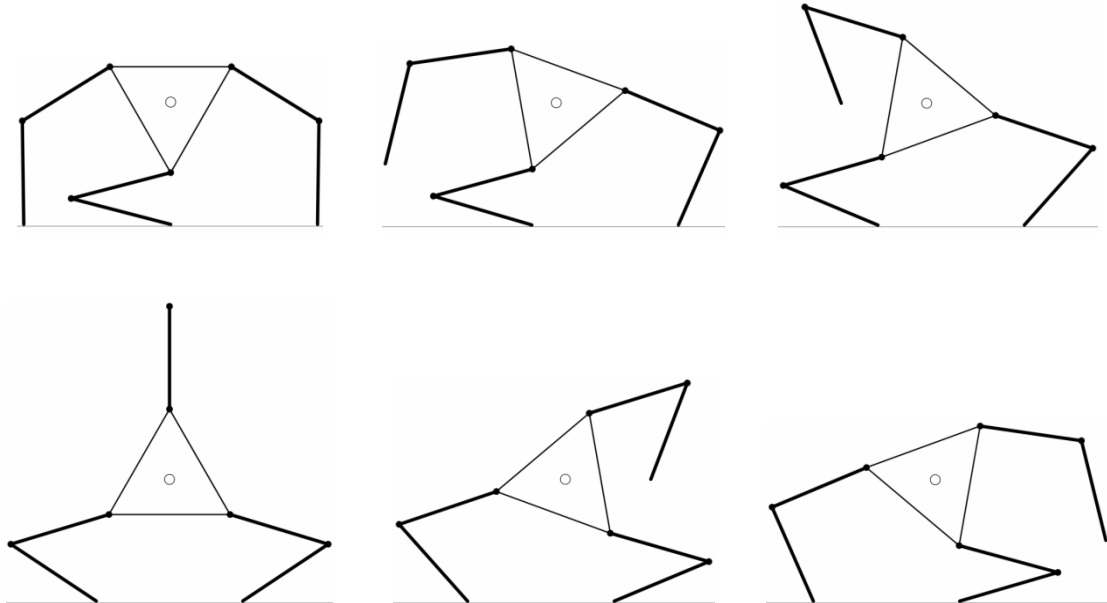

Figure 2.2: A  $100^\circ$  rotation of the Tumbleweed mode.

### 2.1.2 Walkover Mode

Figure 2.3 shows the statically unstable mode that must be stabilized by the controller. There is a unique stage in this mode, when one spoke is providing support while the other two are off the ground, providing stabilization. The motion maintains the center of gravity above the support at all stages of the hub rotation.

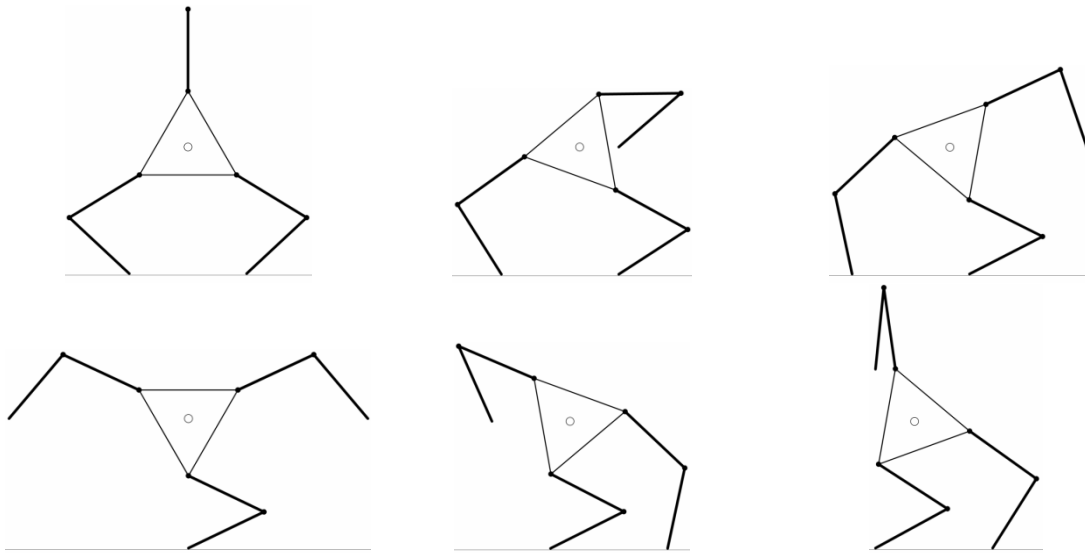

Figure 2.3: A  $100^\circ$  rotation of the Walkover mode.

As the balanced hub rotates, the next spoke tip will eventually contact the ground. The center of gravity will be shifted above this contact point and the sequence repeats. The gait shown in Figure 2.3 matches the Tumbleweed mode gait.

### 2.1.3 Platform Climbing Mode

This mode may apply to stairs or large obstacles. The hub will rise, initially with two spokes on the lower surface, until the third spoke can be rested on top of the platform. The Walk & Roller may balance on one spoke to increase the vertical reach. One configuration will place the lower segment of the third spoke on the platform surface with the middle joint near the edge. The first spoke will still be in contact with the ground below and the second spoke will be rotating overhead to move the center of gravity. As the center of gravity passes above the platform's edge, the weight may be transferred entirely to that support.



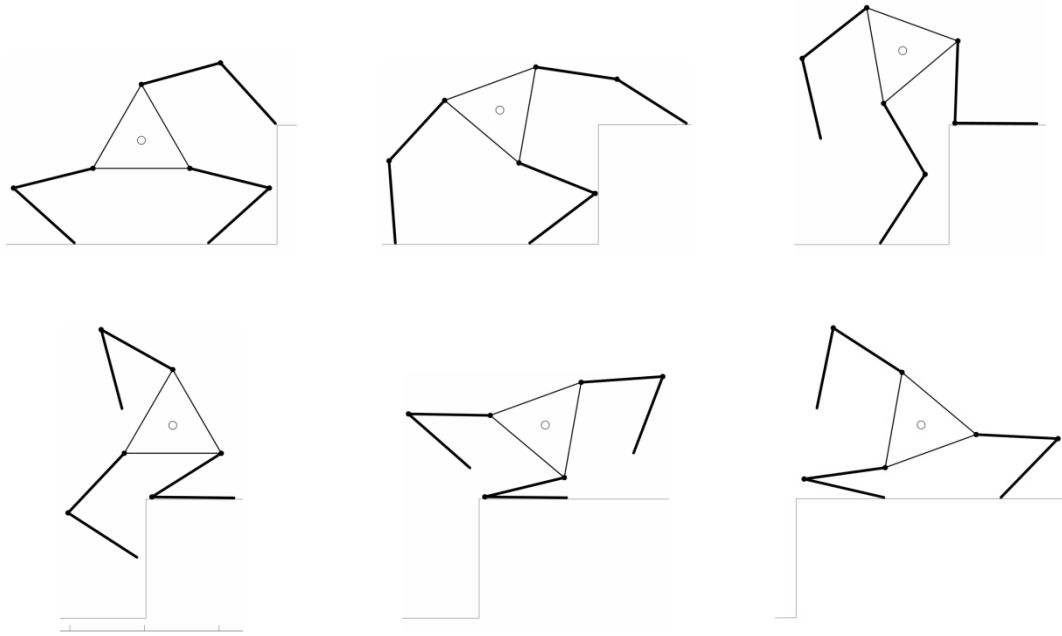

Figure 2.4: Platform Climbing mode.

Figure 2.4 demonstrates the process in which a single horizontal platform may be overcome. Again, the circle approximates the center of gravity, which is kept above a support at every stage. The edges of spoke segments may be used to provide a wide support area or the Walk & Roller may instead balance on a single spoke joint or tip. The process may be repeated to ascend a series of steps. Some of the stages may be omitted for a steep staircase.

#### 2.1.4 Narrow Passage Mode

For passages with low clearances, the Walk & Roller may move by keeping the hub near the ground and creep along with two spokes behaving like inch worms. Instead of using a reciprocating motion like the animal, the Walk & Roller may fully rotate the lower segments to work like paddles with the upper segments oscillating just enough to

maintain a low ride height. Figure 2.5 shows the reciprocating strategy in which the hub's edge is used for a momentary support.

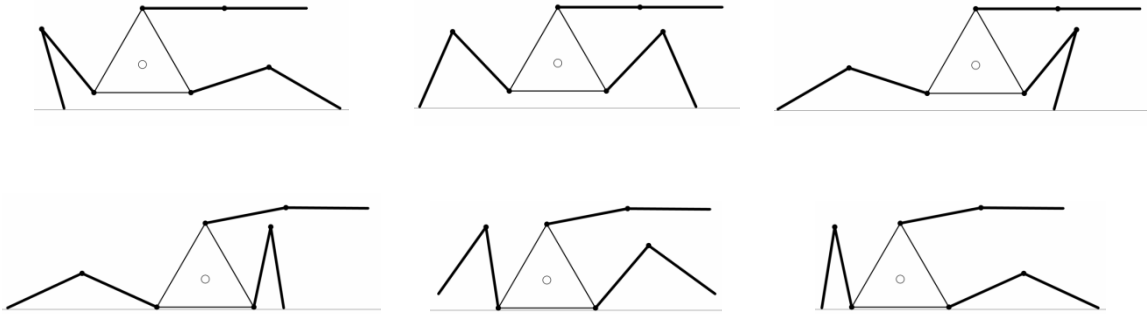

Figure 2.5: Narrow Passage mode.

### 2.1.5 Shaft Ascension Mode

The Walk & Roller is designed to shimmy in shafts having parallel surfaces to climb. This is a very slow mode because the hubs cannot reposition their spokes simultaneously. One hub may support itself with the contact of all three spokes to keep from falling. The other hub uses two spokes in contact with the walls to resist translation and the opposite hub to resist rotation. The free spoke (one out of six) may relocate to a higher position. While all six spokes are in contact with the walls, the Walk & Roller will raise both hubs in unison by a small amount. Next, the opposite hub may relocate its lowest spoke to a new higher position. Each spoke may be relocated in this manner while the other five are securely in contact with the shaft walls. Figure 2.6 shows the repositioning of two spokes of the same hub. The figure fails to include the movements of the opposite hub, but the motions can be inferred as occurring only when the shown hub has three points of contact.



Figure 2.6: Shaft Ascension mode.

### 2.1.6 Transition Between Vertical and Horizontal Travel

This sequence provides a path between two other modes, the Shaft Ascension Mode and one of the translation modes or in reverse. This path is designed to be strictly autonomous by sensing the surfaces within reach and making a decision about the necessary geometries. The decision will also be based on information about the relative slopes and distance between contacts.

For the transition from a horizontal surface to a vertical shaft, the Walk & Roller will use a free spoke to detect the location of the vertical surfaces to determine the center.

One of the two support spokes will move to provide a support at that central location between the vertical surfaces. Then the Walk & Roller will rise into the vertical shaft while balancing on one spoke. When high enough, the two upper spokes will spread to grip the vertical surfaces. The Walk & Roller may now begin the shaft ascension sequence.

The transition from a vertical shaft to a horizontal surface requires the presence of a ceiling within reach. The Walk & Roller will detect the locations of the floor and ceiling and form a brace between the two surfaces in order to shift the center of gravity over the edge. The Walk & Roller may now begin one of the horizontal movement sequences.

## 2.2 Design Problems and Solutions

The design choices sprout from compromises between simplicity and complexity, compactness and bulkiness, speed and torque, and expense. The greatest challenge is developing a compact, simple platform that is capable of producing high joint speeds and large joint torques alternatively and on demand. The tentative solution is to satisfy torque requirements such that all modes can function.

Another significant challenge is developing communication between continuously rotating components. The upper spoke segments are limited to a  $320^\circ$  sweep, so wiring the upper segments' sensors is trivial. However, the lower segments are able to rotate without any mechanical limit. It is a greater challenge to send data signals from the lower segments' sensors to the microprocessor. Additionally, the Walk & Roller robot will have two hub assemblies complete with one microprocessor each. It will be

necessary to transmit data signals between the microprocessors across a continuously rotating joint. Since each hub may have an independent power supply, the transmission may be made with wireless communication hardware. The lower spoke segments will likely not have independent power supplies to support wireless communication hardware. The current solution design incorporates the use of custom slip rings for data signals. However, other strategies, such as the implementation of passive wireless transmitters (i.e. Radio Frequency Identification devices) may be tested as candidate solutions.

There is no mechanism currently designed to assist with self-righting if the Walk & Roller falls over onto one of the hub surfaces. The planar nature of the hub and spoke movements limit the Walk & Roller to operate on surfaces that are nearly level with respect to the points of contact for both hubs. The Walk & Roller will only be capable of traversing steep inclines by a very limited skew. When the hubs are using different radii to turn, care must be made to maintain the center of gravity within a region of stability.

Three solutions to falling over have been proposed. The passive one adds a curvature structure to the hub face to allow rocking back to the correct orientation. The actuated solution utilizes an extendable rod to push the Walk & Roller back up to the correct orientation. Since the current design has the lower spoke segments cantilevered away from the outer hub plane, the spokes may be used to produce an unstable platform that tipping back to the correct orientation. With the spokes on the ground producing a region that does not support the hub's center, the spokes in the air may be used to further extend the center of gravity and prepare to catch the Walk & Roller's fall.

### 2.2.1 Specifications That Are Coupled

The output torque of a geared motor is related to the size of the motor, the output current capacity of the motor driver and the gear reduction to the output shaft. The minimum size and strength of the Walk & Roller's structure depends on the motor size, the joint torques and other stresses due to weight and spoke tip forces. The structural components' weight depends on the size and strength requirements. The geometric configurations and total weight determine the necessary joint torques for proper operation. As a consequence, there is a circular dependence between the power output of the actuators and the dimensions of the structure. Additionally, to allow untethered mobility, the on-board power source must be considered in the above relationships.

### 2.2.2 Physical Limitations

Motivated by safety, cost and ease of fabrication, the size is artificially limited to the approximate scale of common radio controlled vehicles. Also motivated by cost, ease of fabrication and availability of off-the-shelf components the Walk & Roller may not be indefinitely miniaturized. Although it is fascinating to work with small and intricate mechanisms, it becomes very difficult to handle and expensive to purchase the tiny components. Therefore, the scale's lower bound is a more tangible constraint. The first prototypes will take advantage of easily accessible hardware (actuators and electronics) sizes to determine the minimum size.

### 2.2.3 Scale and Design Compromises

If the design is to remain small, the available power supply and payload will limit the support of sensors or extra actuated functionality. The initial prototypes are not intended to do work. Therefore, acceptance of the limited functionality allows the design to remain small. Increasing the size may lead to Walk & Roller robots capable of object handling or other useful environmental manipulation. Larger versions may lead to additional opportunities for features and autonomy. However, safety becomes a concern that grows with the Walk & Roller's proportion.

### 2.2.4 Peripheral Design Constraints

To test the feasibility of the Walk & Roller design, it is preferable to reduce complexity for the initial prototypes. The design will make the most use of the fewest actuators and moving parts as possible. No accommodations for payload will be made. Additionally, the power supply and possibly the control calculations will be off-board. Sensors that are often included for mobile robots for environmental sampling, mapping or localization may be excluded from the Walk & Roller at first. Until the design is mature, it is preferred to maintain a low cost for experimental prototypes and redesigns.

The research emphasizes the development and control of the novel locomotion modes. Geometric models are used for static and quasi-static planning. A dynamic model will be used to produce the equations of motion which allow for the control and motion planning of high-speed modes. The feedback control strategies for joint rotation (end-effector positioning), active suspension, stabilization and terrain estimation will be considered. The motion planning is developed for open-loop control with assumptions made about the terrain or closed-loop control for accurate movements. Future research may include more sophisticated terrain estimation, motion planning strategies and locomotion modes.

### 3.1 Geometry

Although the design appears complicated, nearly every configuration may be described by a set of triangles for which the lengths and angles are known, observable or derivable. The simulation is assumed completely observable, but the current prototype has small regions of unobservable joint rotation. This section illustrates the calculations and considerations made to develop the equations of motion and control algorithms. The following sections describe geometric calculations using the hub's center as a reference. Appendix A has more details about considerations with regards to other reference points.



### 3.1.1 Angle and Segment Definitions

Figure 3.1 shows the notation used throughout the project's descriptions. The spoke segments are drawn with the heaviest line weight for clarity. The lightest lines represent mathematical relations defined to make other calculations feasible. The Hub's  $0^\circ$  Axis provides a reference for the hub's rotation, denoted  $Ha$ , as the angle measured counter-clockwise from the positive x-axis. Each of the Pivot's  $0^\circ$  Axis are located  $120^\circ$  apart with the first  $90^\circ$  from the Hub's  $0^\circ$  Axis. The exact angle between  $Ha$  and the Pivot's  $0^\circ$  Axis is called  $Pa$ . The Upper Segments'  $0^\circ$  Axes pass from the respective pivot joint through the middle joint. The Pivot's  $0^\circ$  Axes and pivot joint's location may be calculated from knowledge of the Hub's location and rotation.

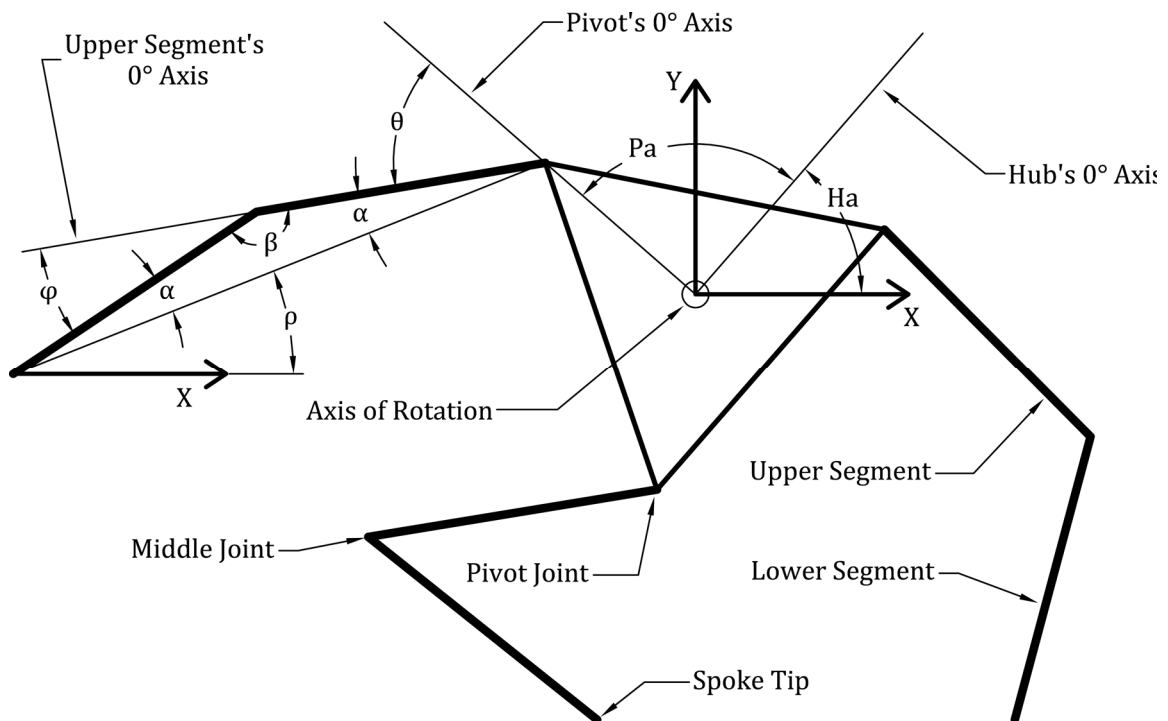

Figure 3.1: Geometry and Notation of a Single Hub

In every configuration, the spokes form an isosceles triangle with the base vertices on the pivot joints and spoke tips (sample triangle shown for upper-left spoke in Figure 3.1). The triangle formed by a bent spoke has at most two unique angles named  $\beta$ , between the segments and  $\alpha$ , between a segment and the triangle's base. The angle of the triangle's base with respect to the positive x-axis is called  $\rho$ .  $\alpha$ ,  $\beta$  and  $\rho$  may be calculated from knowledge of the Pivot Joint's and Spoke Tip's locations.

The most critical angles to know,  $\theta$  and  $\varphi$  may be derived from  $Ha$ ,  $\rho$  and the Pivot's  $0^\circ$  Axis.  $\theta$  and  $\varphi$  are used for positioning and feedback control via information from rotary sensors at the joints.

### 3.1.2 Inverse Kinematics

When the hub's location and orientation are known or assumed, the relative spoke tip locations may be specified. The specified locations may be used to determine joint angles as required by the desired geometry. There are several simple trigonometric relationships for the joint angle calculations, as follows:

Let  $D$  be the distance between the pivot joint and tip of the same spoke. Let  $L$  be the length of each spoke segment. Let  $\alpha$ ,  $\beta$ ,  $\rho$ ,  $\theta$ ,  $\varphi$ ,  $Ha$  and  $Pa$  remain as defined in the previous section (Figure 3.1). Relative to the hub's center, let  $x_t, y_t$  and  $x_p, y_p$  denote the coordinate pairs for the tip and pivot joint locations, respectively. Then:

$$\alpha = \cos^{-1}\left(\frac{D}{2L}\right) \quad (3.1)$$

$$\rho = \tan^{-1}\left(\frac{y_t - y_p}{x_t - x_p}\right) \quad (3.2)$$

$$\theta = \alpha + \rho - Ha - Pa \quad (3.3)$$

$$\beta = 180^\circ - 2\alpha \quad (3.4)$$

$$\varphi = 180^\circ - \beta = 2\alpha \quad (3.5)$$

All angles are derived from imaginary triangle formed by the pivot joint and tip locations. It is important to notice  $\alpha$  and  $\beta$  are always positive which implies a single solution to the location of the middle joint. However, the middle joint may have two unique solutions for each set of pivot joint and tip locations. This problem is solved in the simulation with a parameter called "bend" that modifies  $\alpha$  when  $\theta$  and  $\varphi$  are calculated. The bend of the spoke indicates the sign of  $\varphi$  which is positive when measured counter clockwise from the Pivot's  $0^\circ$  Axis.

### 3.1.3 Forward Kinematics

Using sensor data to determine geometry is also simple from a hub centric perspective. All relevant lengths are known by design. Calculating relative middle joint and spoke tip locations are a matter of summing the products of distances with the sines and cosines of the rotary sensor angles. Calculations for absolute positions rely on knowledge or assumptions made regarding the hubs' position and orientation. The only complication exists in the electrical range of the rotary sensors. While mechanically, the potentiometers do not have limits, the resistive carbon strip only completes  $320^\circ$  of the circle. This implies that there is a  $40^\circ$  sector where the actual rotation is unobservable. This region is aligned such that the upper and lower segments overlap and the lower

segment would only be passing by. There is no useful configuration for the spoke tip in this region.

#### 3.1.4 Reverse Kinematics

Since the Walk & Roller's spokes may be described as independent robotic arms connected to a common base, it stands to reason that forward kinematics may be employed to determine the spoke tip locations relative to the hub. However, if only the spoke tip locations are known (to some reference frame), forward kinematics cannot provide information about the hub. Therefore, reverse kinematics have been developed to determine both the position and orientation of the hub with respect to the spoke tips. This calculation is used in simulations to prescribe joint angles and use constraints to determine spoke tip locations to evaluate the smoothness of the hub's trajectory.

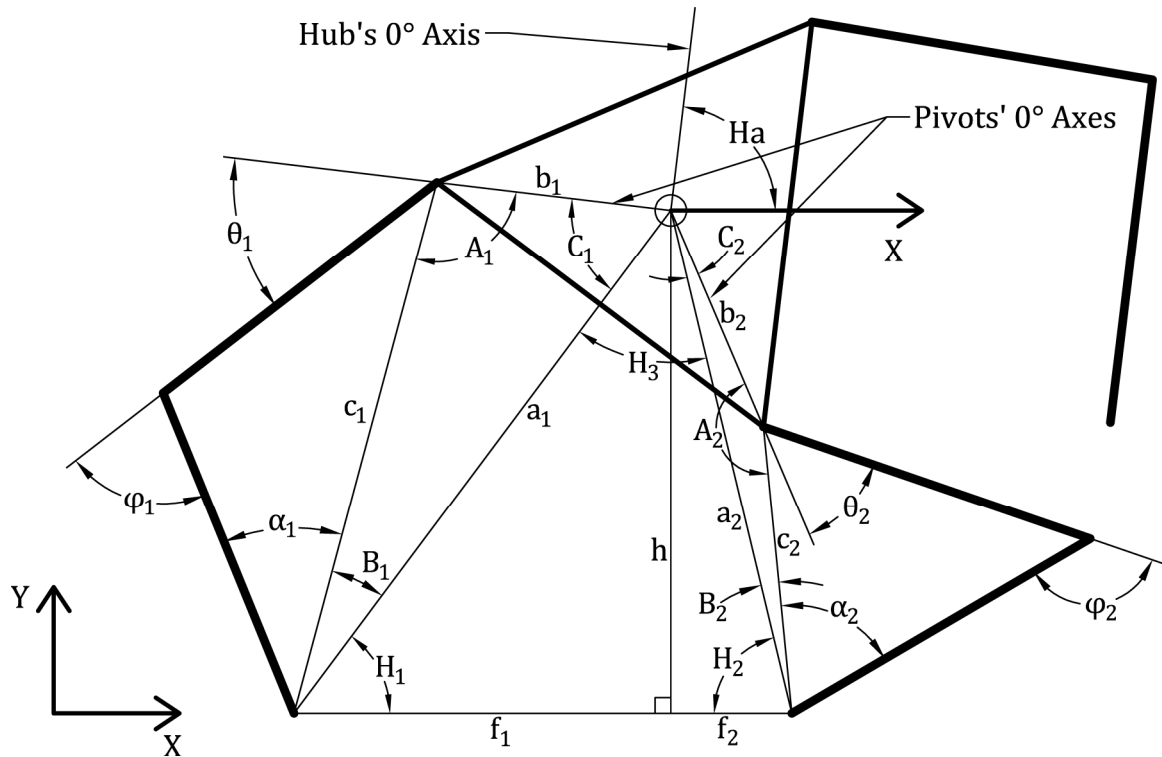

Figure 3.2: Notation of mathematic triangles used for reverse kinematics.

Figure 3.2 shows the problem graphically with labels for reference. The method is referred to as reverse kinematics to signify the calculations are from the opposite direction of forward kinematics. In forward kinematics, the base and joint angles are known. In reverse kinematics, the end-effector (spoke tip) and joint angles are known. The drawing shows information given for two spokes, the third could be used to verify calculations or contribute to terrain estimation.

Let  $b_1 = b_2$  be the distance between pivot joints and the hub's center (which is known by design). Let  $L$  denote the length of each spoke segment. Assume the lower two spoke tips are in contact with a flat horizontal surface. Notice uppercase and Greek letters signify angles while lowercase letters signify the lengths of triangle sides. Additionally, Greek letters signify angles that are known (by sensor information) or are

trivial to calculate (i.e.  $\varphi = 2\alpha$ ). The calculations below are equivalent for each spoke.

Therefore the subscripts are omitted for the time being.

$$A = 180^\circ - \theta - \alpha \quad (3.6)$$

$$c = \frac{L \sin(180^\circ - 2\alpha)}{\sin \alpha} \quad (3.7)$$

$$B = \tan^{-1} \left( \frac{b \sin A}{c - b \cos A} \right) \quad (3.8)$$

$$C = 180^\circ - (A + B) \quad (3.9)$$

$$a = \frac{b \sin A}{\sin B} \quad (3.10)$$

The following equations take the relationships derived for each spoke to determine the hub's location and orientation. The subscripts are included to distinguish values from multiple spokes.

$$H_3 = 120^\circ - C_1 - C_2 \quad (3.11)$$

$$H_1 = \tan^{-1} \left( \frac{a_2 \sin H_3}{a_1 - a_2 \cos H_3} \right) \quad (3.12)$$

$$H_2 = \tan^{-1} \left( \frac{a_1 \sin H_3}{a_2 - a_1 \cos H_3} \right) \quad (3.13)$$

$$h = a_1 \sin H_1 = a_2 \sin H_2 \quad (3.14)$$

$$f_1 = a_1 \cos H_1 \quad (3.15)$$

$$f_2 = a_2 \cos H_2 \quad (3.16)$$

The set of distances  $h$ ,  $f_1$  and  $f_2$  describe the hubs' relative location to the spoke tips. Calculating the hub angle,  $H_a$ , is a bit more delicate because  $H_a$  has a different angular relationship with each pivot's  $0^\circ$  axis. In Figure 32, the angle between  $H_a$  and  $Pa_1$  is  $90^\circ$ . Using the angular sum of a convex four-sided polygon,

$$H_a = 180^\circ - A_1 - B_1 - H_1 \quad (3.17)$$

Additional calculations may be used for verification. If all three spokes are making contact with a common surface, there may be three sets of the relationships described in Figure 3.2 (i.e. spoke sets 1 & 2, 1 & 3, 2 & 3). The calculations may be used by a filter to reduce error. It may also be possible to improve terrain estimation by repeated application of this process with small tip relocations between iterations.

### 3.1.5 Reach, Pace and Natural Gaits

The reach defines the tallest obstacle that can be traversed, the widest gap that can be crossed or the furthest object that can be manipulated by the Walk & Roller. These distances are not yet well defined. The relation depends on specified dimensions, inherited physical properties and desired stability for the given terrain type. The specified dimensions come from the design whereas the inherited properties present as traction or weight distribution.

The pace is expected to be slower than comparably sized vehicles since the articulated spokes require high torque from the motors to support the Walk & Roller's weight. Since the spokes are fully back-drivable and the suspension is entirely active, the motors are geared to produce high torques and sacrifice speed. Forward travel is limited

to rate at which a trailing spoke can be moved to the leading position. Additionally, some locomotion relies on moments created by gravitational and support reaction forces on opposite sides of the center of gravity. This relationship also limits the velocities that are obtainable.

When rolling, the distance between spoke tips in contact with the ground is related to the size of the hub. The effective radius of the hub is defined by the distance between the hub center and the base of each spoke (pivot joint). This effective radius corresponds to a distance that is the length of an arc described by a  $120^\circ$  angle. This distance is called the Rolling Gait. When the tips are spaced accordingly, the Walk & Roller support is vertically symmetric and lacks a directional bias. At any other spacing, the symmetry vanishes. The lack of symmetry may be desirable for some modes or terrains.

Several walking strategies are under consideration and further research may reveal a varied set of gaits to be optimal for separate purposes. A simple walking gait may use the largest possible spoke sweep for a given ride height that maintains stability. Preliminary analysis of simulation materials and computational expense indicates the locomotion sequences will be predetermined by a powerful computer and the on-board microprocessor will have a limited selection of strategies from which to choose.

As with walking, a climbing gait will depend mostly on the terrain structure and a selection of the geometry that provides sufficient traction. In a uniform shaft that is tall enough, it is expected that the Walk & Roller will settle into a steady-state pattern of repeated climbing sequences. Platform climbing may evade predetermined strategies, so naturally, the movement may not be regular or even describable as a gait.



## 3.2 Static and Quasi-static Modes

Some locomotion modes may be approximated as slow motions, particularly when estimating terrain by tip contact or climbing. The net acceleration imparted on the Walk & Roller's mass is very close to zero. During these situations, some configurations or each step of the analysis may be approximated as static.

### 3.2.1 Stable Modes

The Walk & Roller is a platform designed to provide smooth motions while traversing a variety of terrain types. To accomplish the desired stability, the Walk & Roller will rely on forming support regions by using at least two points of contact per hub with the center of gravity centrally located in the support region. The three spokes are capable of providing a continuous region of support that may be described as two adjacent regions. To maintain a stable locomotive mode, the center of gravity will only move between the adjacent support regions. This notion of the support region does not account for disturbance rejection due to ground movement, slippery surfaces, or external forces such as wind.

### 3.2.2 Unstable Modes

These modes occur when the Walk & Roller maintains a configuration near an unstable equilibrium above a narrow support region. This includes the low-speed Walkover mode and raising the hub with all of the weight supported by one spoke. The dynamics resemble an inverted pendulum and must be actively balanced. The balancing

strategies may include rotating the hub or modifying the spoke extension to shift the center of gravity, or spinning an optional internal inertial mass.

Due to the independent behavior of the two hubs, it is possible to coordinate the stabilization of one unstable hub by the support of the other hub in a stable configuration. This allows greater flexibility in unstable configurations.

### 3.2.3 Minimum Torques Required to Facilitate the Desired Modes

In the absence of dynamic loading, the minimum torques are related to the geometry, friction where applicable, and the mass of the robot. The largest torques occur when each hub of the Walk & Roller is supported by one spoke at a low height. Otherwise, the largest torque requirements may be seen in the Shaft Ascension Mode when the available traction is low.

The following equations demonstrate how the joint torques were calculated. Figure 3.3 shows a single spoke in contact with the ground, the configuration is assumed statically stable. Let  $CG$  be the location of the center of gravity of the entire hub assembly. This may be calculated by summation of the centers of masses of each moving component.  $Fx_1$  and  $Fy_1$  are the net forces acting on the hub.

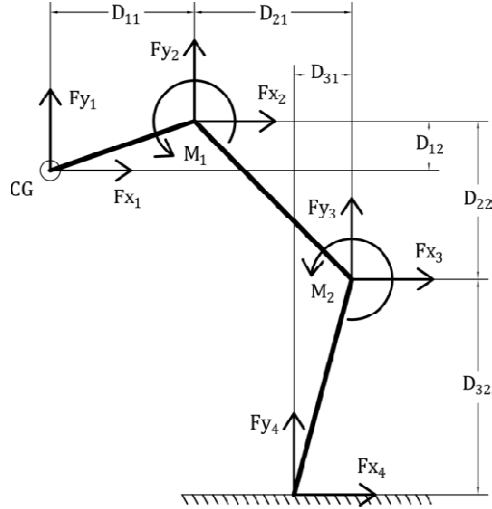

Figure 3.3: Forces and moments of a load carrying spoke on a horizontal surface.

$$M_1 = Fx_1 D_{12} - Fy_1 D_{11} + Fx_3 D_{22} + Fy_3 D_{21} \quad (3.18)$$

$$M_2 = -Fx_2 D_{22} - Fy_2 D_{21} + Fx_4 D_{32} - Fy_4 D_{31} \quad (3.19)$$

The moments are indicative of the joint torque requirements, but the exact motor selection will have to include transmission and frictional losses. Assume  $Fx_1 = Fx_2 = Fx_3 = Fx_4 = 0$  and  $Fy$  is the portion of the Walk & Roller's weight placed on the respective spoke. Thus,  $Fy_4$  is the reaction force at the spoke tip that is equal and opposite to  $Fy_1$ . For the purpose of summing moments, the net forces at joints 2 and 3 may be written as components instead, i.e.  $Fy_2 = Fy_3 = Fy_1 - Fy_4 = 0$ . The correct component must be selected to produce a positive moment sense. Therefore, equations A.13 and A.14 may be written as

$$M_1 = Fy_1 D_{11} + Fy_3 D_{21} \quad (3.20)$$

$$M_2 = Fy_2 D_{21} + Fy_4 D_{31} \quad (3.21)$$

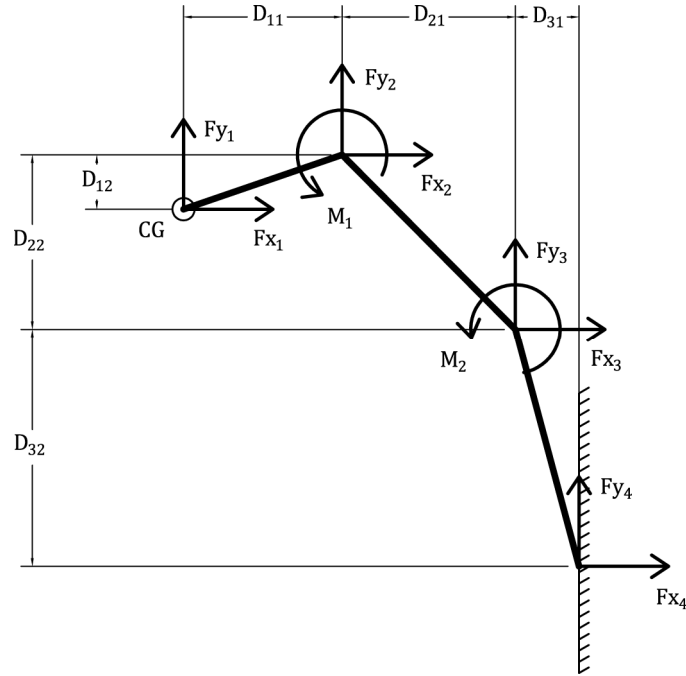

Figure 3.4: Forces and moments of a load carrying spoke against a vertical surface.

Figure 3.4 shows the statically stable configuration of one spoke supported by a vertical surface. The joint torque calculations are similar to those of the previous section. However, the restoring force  $Fy_4$  is related to the normal force  $Fx_4$  by the coefficient of friction,  $\mu$ , at the contact surface:

$$Fx_4 = \frac{1}{\mu} Fy_4 = Fx_1 \quad (3.22)$$

Using the same notion of force components again,  $Fx_2 = Fx_3 = Fx_4 - Fx_4 = 0$  and summing terms with a positive sense yields,

$$M_1 = Fx_1 D_{12} + Fx_3 D_{22} \quad (3.23)$$

$$M_2 = Fx_2 D_{22} + Fx_4 D_{32} \quad (3.24)$$

Table 3.1 lists the maximum torques for various configurations. The values are for the current prototype which weighs 5.24 lbs. The joints are assumed to have no friction, but the spoke tips are assumed to have no-slip with the contact surfaces. The torque calculation only uses spoke tips for contact, the segment lengths, joints and hub edges are excluded from calculations. In the case of vertical surfaces, the coefficient of friction with the spoke tips is assumed to be 0.5.

Table 3.1: Maximum joint torques required for the current prototype design.

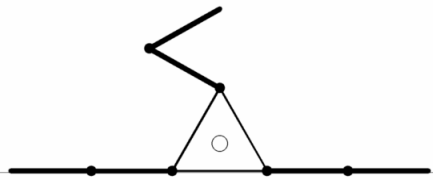
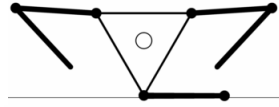
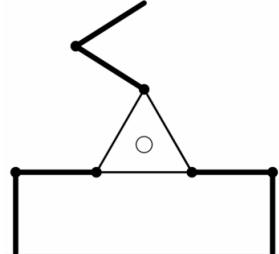
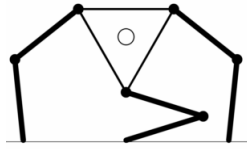
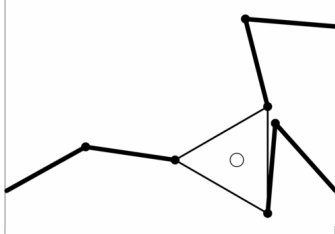
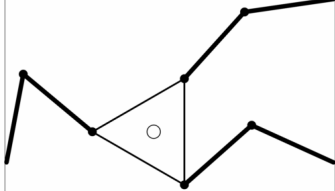
Configuration	Max. Torque	Location
	29.6 in-lb	Middle joint of left spoke
	57.6 in-lb	Both joints of center spoke
	22.8 in-lb	Pivot joint of left spoke
	18.7 in-lb	Pivot joint of left spoke
	34.0 in-lb	Middle joint of lower right spoke
	47.9 in-lb	Middle joint of left spoke

### 3.3 Dynamic Modes

The Walk & Roller is expected to operate at speeds and in configurations where the stability is maintained only by a dynamic balance of forces and accelerations.

### 3.3.1 Equations of Motion

The equations of motion will be developed using Lagrangian Mechanics. Based on the combination of simple geometry and numerous degrees of freedom, the derivation is straight forward but tedious. Once the equations of motion are derived, constraints may be added to the simulation. The Walk & Roller benefits again from symmetry, but suffers from discrete contact with the constraining surfaces.

### 3.3.2 Dynamic Center of Gravity

Every asymmetric configuration of the Walk & Roller produces an offset of the center of gravity from the hub's actual center. Joint rotations and hub translations further affect the center of gravity's location relative to the support region. The net forces and accelerations acting on the moving center of gravity affects the Walk & Roller's stability. The potential benefits or problems created by this effect are not yet resolved.

### 3.3.3 Dynamic Moment of Inertia

As described with the dynamic center of gravity, the moment of inertia is sensitive to changing configurations. Since the Walk & Roller may behave like a wheel with a varying radius, the moment of inertia may be adjusted for specific purposes. It is assumed that the moment of inertia greatly affects the attainable speeds of rotation. The potential benefits or problems created by this effect are not yet resolved.

### 3.3.4 Stable Modes

A locomotive mode may be considered stable if the net force and net acceleration vectors are in equilibrium. This may occur during high speed operation when one spoke is in contact with the ground pushing the hub upwards while gravity is pulling the hub downwards. When there is a distance between those two force vectors, a couple is formed that imparts an angular acceleration. By making contact with the next spoke, the angular acceleration is transferred, by some amount, to a linear acceleration. The accelerations are countered by frictional, inertial, drag and rolling resistances or other types of losses. When these forces are in equilibrium, the Walk & Roller develops a steady-state velocity. The mathematics of these concepts have not yet been developed.

### 3.3.5 Unstable Modes

The Walk & Roller may be capable of operating in dynamically unstable modes. This includes situations where the spokes have only momentary contact with the ground during very high speed galloping or perhaps jumping.

### 3.3.6 Speed and Torque Requirements for Dynamic Stability

This is an area of great interest and deserves significant consideration. At the moment, there have been no developments made.



### 3.4 Controls

The Walk & Roller is a complex remotely operated vehicle that will allow operation to remain simple by the implementation of sophisticated control autonomy. The control strategy begins with classical control of simple features leading to the development of complex and robust algorithms. Even though the motion planning is complicated, the dynamics are not. Therefore, it may be preferable to implement modern controls after the prototype and equations of motion are well-defined.

#### 3.4.1 Controllability and Observability

With the exception of the moving spoke tip (see section 4.2.4), every degree of freedom has an associated actuator. Therefore, the Walk & Roller is fully controllable. Observability depends on how the controls are defined. The Walk & Roller will have an assortment of sensors to detect its geometric configuration and relationship with points of contact and Earth's gravity. The operation is intended to provide relative direction only. There are no plans to provide sensors for geographic localization or absolute directions.

#### 3.4.2 Successive Loop Closure

The current controls strategy is broken into three distinct levels where the third level is contained entirely in the second and the second is contained entirely in the first. The level divisions are based on the dependence of actions that may be completed at different rates. The third level is the joint positioning feedback control. Although the joint rotation speed depends on external factors, the control algorithm must respond

quickly. The rapid response of the joint rotation control facilitates the second level of control: stabilization and suspension. This level of control will provide disturbance rejection from the environment to allow predicted behavior to occur. The first level of control is the path planning from user commands. This level is expected to be the slowest and rely on the completion or intermediate results of the other levels.

### 3.4.3 Open-Loop Path Planning

The locomotion modes are expected to be robust enough to perform well for a variety of terrains. However, an open-loop approach will only perform well when the actual terrain closely resembles an idealized description. In some situations, the user may prefer to impose their judgment about the terrain to affect the locomotion performance. In this case, the Walk & Roller may rely on predetermined locomotion sequences for rapid travel. The open-loop operation is limited to the first level of control.

### 3.4.4 Closed-Loop Path Planning

Terrain estimation by spoke contact sensing is likely to be computationally intensive. The performance of locomotion during terrain estimation will be slower than the open-loop counterpart, but it may be necessary to safely or correctly traverse a challenging terrain. Some modes, such as platform climbing or shaft ascension, may require information about the environment to function at all.

### 3.4.5 Stabilization of Unstable Modes

The second level of controls will have to respond to disturbances faster than the path planning level. Stabilization is the control element designed to reject disturbances regarding balance. To operate near an unstable equilibrium, the Walk & Roller must shift its center of gravity to remain above the support point at all times. Depending on the physical characteristics, the time scale for falling may be fast compared to the intended motion. The joint rotation commands made by the path planning may be modified by the stabilization control to enhance balance.

### 3.4.6 Active Suspension

The Walk & Roller does not have any passive suspension components. The suspension is instead provided by the control algorithm's second level as required for disturbance rejection. Suspension and stabilization are distinct and may be uncoupled. Suspension is the control element which responds to disturbances with loading.

The controller will actively seek to maintain specified joint rotations and protect the Walk & Roller from impacts or falling. The controlled response is one that behaves like a spring (resistance is proportional to displacement) and a damper (resistance is proportional to velocity). The current control strategy uses a proportional derivative feedback loop based on loading information collected from the contact sensing tips. As with stabilization control, the joint rotation reference commands may be modified by the suspension control to reduce the effects of extreme shock loads.

### 3.4.7 Closed-Loop Spoke Tip (End-Effector) Positioning

This is the third level of control and by far the fastest. Positioning feedback is performed from information collected by the joint's rotary sensors. Even if the path planning specifies slow actuator speeds, the positioning control will treat the reference command as an average to allow for fine adjustments along the joint's trajectory. The current strategy is a proportional integral control. Future controls strategies will use the derivative control as well.

## Chapter 4 Experimentation

There is a simulation component and an experimental component of this research. In the simulation, a model is constructed from the designed geometry, prescribed masses, equations of motion and physical constraints. The model is tested with various control strategies. The experimental portion consists of physical construction of a single hub. The current Walk & Roller hub design is tested on an inclined surface for reduce gravitational effects to avoid over-stressing the hardware.

### 4.1 Computer Aided Design/Finite Element Analysis

SolidWorks was used extensively to draft design ideas as well as verify preferable dimensions. Several components were analyzed by the built-in finite element analysis tool, SimulationXpress, to reveal locations that required more (or sufficed with less) material to maintain a desired strength. There are two cases when material removal is necessary; when adding holes for screws or the passage of wires or belts, etc. and cutting grooves or flats on rods for torque transfer.

### 4.2 Previous Versions

The developmental process of the Walk & Roller has produced many conceptual designs. While the theme of two triangular hubs with three spokes each has not changed, the structural arrangement and hardware selection has significantly evolved. Each revision exposed some new problems and solutions. All concepts were evaluated by CAD for feasibility by adding greater realism to the model until a major failing was

discovered. The most common failing was interference between moving parts. Only two of the designs were pursued for fabrication and testing. The first prototype utilized worm gears with the motor shafts perpendicular to the joint axes. The second prototype utilized timing belts with the motor shafts parallel to the joint axes.

#### 4.2.1 Component Selection Process

Both predecessors were based on utilizing unfamiliar technology. As a result to such an approach, many of the original components were found to introduce unforeseen limitations or problems during the testing phase. Significant challenges presented themselves while designing and implementing the two power transmission systems. Therefore it was necessary to design the prototypes with some flexibility to test various sizes and combinations of parts.

#### 4.2.2 Worm Drive Testing Apparatus

The first prototype was based on a design to use the large reduction ratios of worm gears (see section 6.4.1 for details). Although the CAD models were well resolved, it was not clear which gear combination would provide the best compromise between torque and speed. Several different gear ratios were selected in several different gear pitches to find the smallest set that would provide the desired performance with sufficient gear tooth strength. Table 4.1 lists the gear combinations that were tested.

Table 4.1: Worm gear combinations tested

Pitch	Gear Ratio	Maximum Size of Diameters [in]	Maximum Size of Widths [in]	Gear Tooth Cross-Section at Base [in <sup>2</sup> ]
48	1:5	0.834	0.375	0.012
48	1:10	0.834	0.375	0.012
48	1:15	1.042	0.375	0.012
48	1:30	1.042	0.437	0.012
48	1:40	1.250	0.437	0.012
32	1:10	1.187	0.437	0.018
32	1:20	1.187	0.437	0.018
32	1:30	1.500	0.437	0.018
24	1:10	1.500	0.563	0.033
24	1:20	1.500	0.563	0.033

To evaluate the gear sets, a testing apparatus was constructed to hold only one spoke. The maximum size of diameters determines the minimum size of the joint that will protect the gears. In addition to testing gear combinations, six different spoke segment lengths were constructed to test the force, speed and reach produced at the spoke tips. The testing apparatus provided insight into the configuration advantages and disadvantages of the varying spoke segment lengths. There were three length options of 3.50", 5.25" and 7.00" for the upper and 3.75", 5.50" and 7.25" for the lower segments. Each segment was evaluated for speed and torque performance to match the best worm gear set. Initial results of the worm gear system abruptly ended testing of this prototype and the spoke segments (see section 6.4.1 for details).

#### 4.2.3 One Hub, One Spoke and Many MXL Timing Belt Options

The second prototype was designed as a platform for testing the control algorithms and performance of the electronics. Since large joint torques are required to lift the Walk & Roller's weight against the full strength of gravity, this design

accommodated the limited torque output of the motors by reducing the effects of gravity.

Figure 4.1 shows how the body functions as a base for one hub as described above.

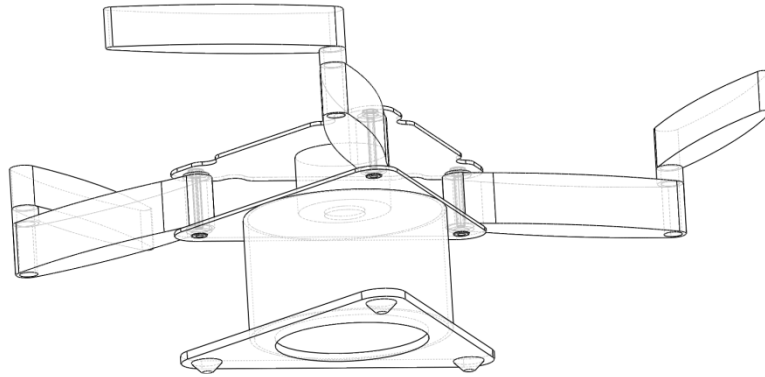

Figure 4.1: Single hub complete with three spokes and low-friction pads on the base.

The body provides a stable base that allows the hub to operate parallel to the ground and low-friction pads for easy movement. A special slippery testing surface will be used to provide greater mobility. The testing surface may be horizontal to eliminate gravitational forces completely or may be held at some small incline to provide testing with a reduced component of gravity.

The spacing of the pivot joints, base of the spokes, have a dimension that allows for testing several different timing belt configurations. The commercially available timing belt systems have limited choices for pulley sizes and belt lengths. Table 4.2 list the MXL size timing belts and associated pulleys that were used in testing.

Table 4.2: MXL timing belt combinations tested. Values are Number of Teeth.

Belt	Pulley A	Pulley B	Centers Distance [in]	Gear Ratio
95	12	36	2.823	1:3
95	16	32	2.833	1:2
90	19	20	2.820	1:1.053



The centers distance of Table 4.2 establishes the distance between the pivot joints and motor shafts. The actual distance is slightly larger to provide tension on the belts which is beneficial to reduce backlash and skipping. The results of MXL timing belt testing are discussed in detail in section 6.4.9.

#### 4.2.4 A Sensing Tip Design That Increased the Degrees of Freedom

Figure 4.2 shows a prototype spoke tip for sensing the direction and magnitude of contact and relative load distribution. The moving tip is connected to two slide potentiometers, one on either side of the tip's pivot axis. The unloaded (reference) position is shown in Figure 4.2(b) and (c). If the load is applied coaxially with the segment, the potentiometers will move in unison as shown in Figure 4.2(d) and (e). If the load had a tangential component, the tip will rotate and the potentiometers will move in opposing directions as shown in Figure 4.2(f) and (g).

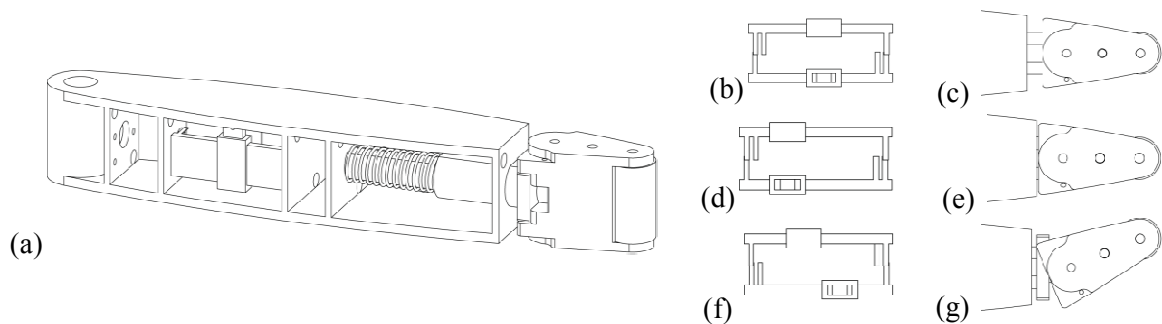

Figure 4.2: This lower segment construction includes a contact sensing spoke tip. (b), (d) and (f) show the positions of slide potentiometers' wiper for the tip configurations of (c), (e) and (g), respectively.

Since the moving part of the tip has a substantial range of motion, the rotation must be considered in geometric analysis. These extra degrees of freedom increase the control strategies' complexity. The unstable modes would be most sensitive to this

additional movement. Additionally, for some loads, the tip locks into place for a significant range of rotation angles. Therefore, the direction and magnitude of the load is not correctly reported by the sensors.

### 4.3 Fabrication of a Working Prototype

The third and current prototype reused the major structural components of the second construction. Most of the design changes are limited to converting the drive system from using the 1/8" MXL wide to the 3/16" wide XL timing belt system. Easily machined 12L14 grade steel components were upgraded to 6061 aluminum alloy. The hub cover with exposed slots for alignment was replaced with a two piece cover hiding the slots. The new cover added 0.090" of additional clearance between the upper segments and hub walls. Making the cover from two parts glued together allowed for finer adjustment in the alignment of coaxial bearing holes.

Once the problems with the timing belts were resolved, the remaining two spokes were constructed and a complete hub assembly was built. The hub is mostly self-contained with on-board microprocessor and motor drivers. The power source (lithium polymer battery) is attached to the operator's remote control for safety. The remote control is connected by cables to the Walk & Roller and allows for mode selection and hub movement control.

#### 4.3.1 Equipment Load Out

The current working prototype has been through many revisions. The current components represent the best available hardware that is compatible with the earliest

construction. The design was centered on the utilization of one motor type, the Maxon 111694 geared motor. Calculations presented in section 3.2.4 demonstrate the joint torque requirements are significantly greater. Graph 4.1 shows the performance specifications (claimed by the manufacture, verified by experimentation) of the motors used. The recommended torque for continuous operation is limited to 2.7 in-lbs. Additionally, the stall torque is limited to 12 in-lbs. The values between recommended and stall are theoretical. The actual limit is smaller due to the failure of gear and shaft press fits inside the transmission. Since the mounting holes and spacing is unlikely to accommodate another motor type, one possible solution is the addition of more gear reduction stages. Another solution is to redesign the Walk & Roller to work with more powerful motors.

Graph 4.1: Performance specifications of the Maxon 111694 geared motor

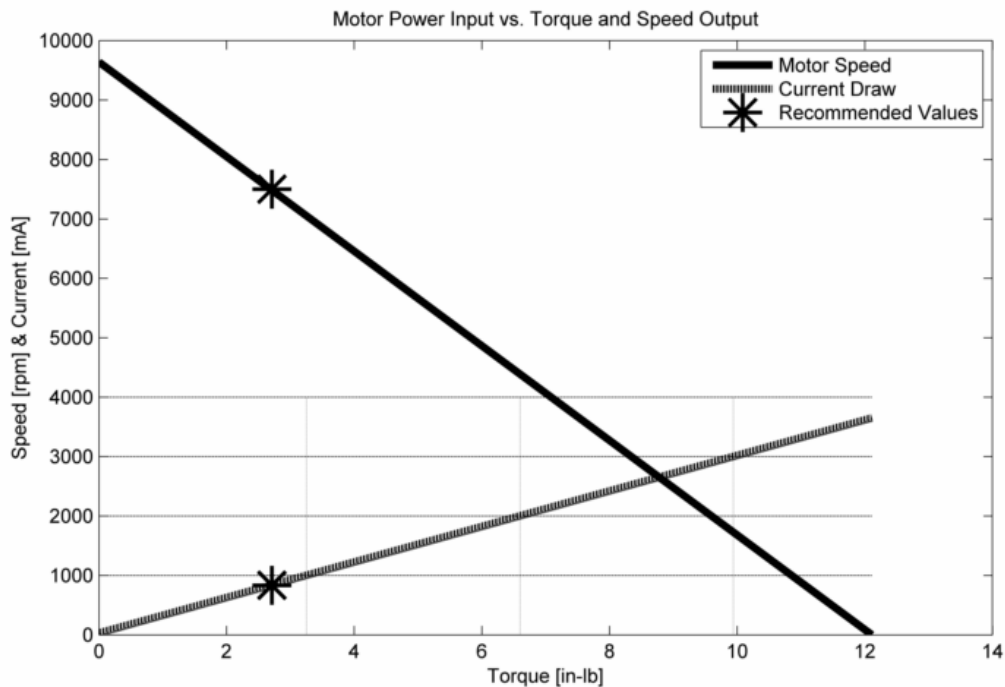

### 4.3.2 Structural Considerations

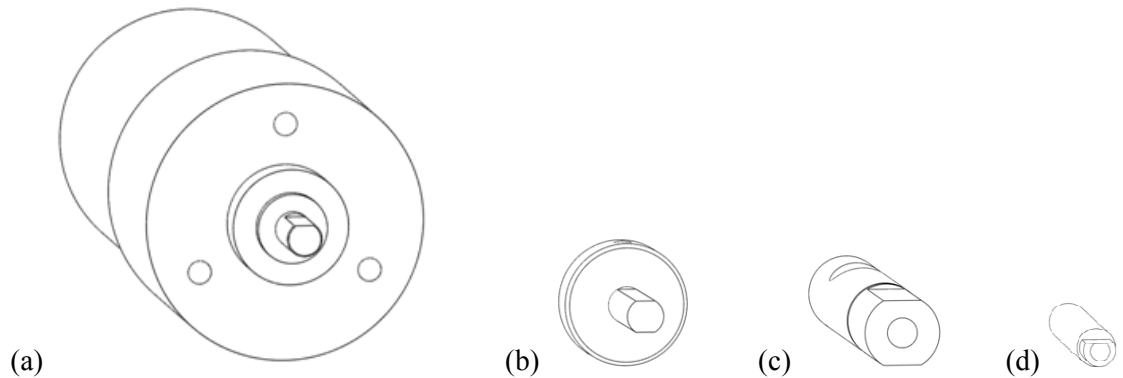

Figure 4.3: These components are used to drive the revolute joints, (a) 3mm motor output shaft, (b) 3/16" pulley shaft and (c) 5/16" pulley shaft. The (d) 4mm rotary sensor shaft drives the through-hole potentiometer wiper.

Figure 4.3 shows the main drive shaft components used throughout the current prototype. The rods are simple circular cylinders with one or two parallel flat sides. The flat sides create a mating surface to transfer torque between the rod and some other drive components. The side not shown of Figure 4.3 (b) has a hole to fit the motor shaft, Figure 4.3 (a). A perpendicular set screw is used to fix rotation. The 3/16" shaft, the 5/16" shaft and the 4mm shaft of Figure 4.3 (b), (c) and (d), respectively, represent components that both transfer torque as well as support structural components. These three shafts are subject to beam forces. Only the 5/16" shaft supports a cantilever.

In order to provide adequate torque transfer, a rod must be able to produce a moment arm. As seen in Figure 4.3, the drive components are rods with parallel flats. Thus torque transfer favors the largest flat length possible. However, the shafts are also structural and the strength is proportional to the cross-sectional area and distribution of the area. Therefore, the structural performance improves with the smallest flats possible.

Graph 4.2 shows the relationship between the length of the flat sides and the cross-sectional area of that rod.

Graph 4.2: Optimization of the flats on structural rods.

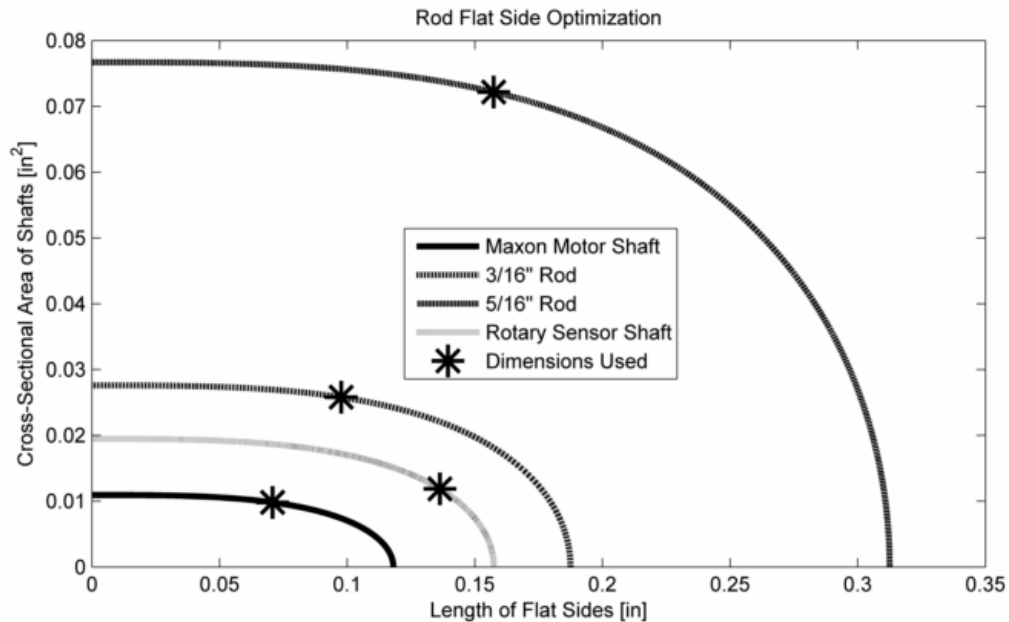

The Maxon motor shaft dimension (not adjustable) is used as a reference to determine the ideal compromise for the custom components. The 3/16" and 5/16" rods must be strong against bending and shear. Although the motor shaft does not have any normal loading in the Walk & Roller, it was designed to handle significant normal and axial loads. In terms of the above plot, the length of the flats were chosen just before the cross-sectional area begins to rapidly decrease. The 4mm rotary sensor shaft was not designed to support any torque loads (the torque required to turn the potentiometer is negligible). The entire length of the rod, except for the small section in the potentiometer is the full 3/16" circle.

#### 4.3.3 Material Selection

The first prototype was made from low carbon steel due to the ease of fabrication, welding and low cost. The second prototype was made from aluminum to reduce weight. Since aluminum is very sensitive to distortion cause by the heat of welding, the tight-tolerance assembly was facilitated by a two-part epoxy binding. The components that were made from an easy to machine steel alloy were replaced with aluminum for the third prototype. The hardware is entirely stainless steel.

Rather than using ball bearings which are heavy and expensive, custom bushings were used. Initially, acetal (Delrin) was chosen for its mechanical properties to be used for the bushings. Acetal has a very low coefficient of friction and is relatively durable. During the development of the second prototype, when it was realized that only small forces would be present, acetal was replaced by polytetrafluoroethylene (PTFE, Teflon). PTFE has a coefficient of friction that is approximately 27% of acetal. Unfortunately, PTFE is not as durable or rigid and already show signs of wear.

#### 4.3.4 Process Selection

The design of the robot had been focused on functionality as well as fabrication feasibility. Designs which utilized specific equipment, to which there was greater access, were favored. At the time, the Coordinated Robotics lab had access to a CNC industrial laser for metal cutting, but not so much for a CNC mill. Therefore, the designs' complex shapes were limited to what could be produced from sheet material. Unrestricted access to manually operated mills and lathes resulted in machined components that remained simple.

#### 4.3.5 Tolerances

The precision held during fabrication was desired to be as great as possible. The primary motivation for precision is the concern regarding backlash or unaccounted movement between actuator and sensor. The single largest error between a design and manufactured dimension has been approximately 0.006". However, the cumulative error across many dimensions has not yet been accounted.

The most significant source of error is the centers distance between the timing belt pulleys. The mounting locations for the transmission components of current prototype was carefully spaced to accommodate specific timing belts and pulleys including some tension for the MXL series. Since the MXL series failed during testing and the XL series was implemented in its place, the original spacing remains as artifacts of the previous system. In spite of efforts to select the XL belts and pulleys that would fit best, the spacing is still not correct.

#### 4.4 Programming

The on-board microprocessor is an Arduino Mega 2560. Programming is performed in the proprietary Arduino environment using the C language. The Baby Orangutans (which are no longer in use) use a standard AVR programmer with code also written in C.

#### 4.4.1 Division of Labor

The details of this section are not applicable for the current prototype. However, since it may be computationally advantageous to divide tasks between multiple processors working in parallel, the strategy deserves some attention. There may exist both the necessity for extra computational power and for additional input connections to the sensors. The Walk & Roller is expected to have at least four sensors per spoke, several sensors in each hub and at least one to detect the relative rotation between the two hubs. As described in section 6.4.4, each absolute digital encoder requires one channel for every bit of resolution. It is expected that a complete Walk & Roller will be made of two equivalent hub assemblies, each with one main microprocessor.

The Walk & Roller's control structure will have stratified levels of computation. The successive loop closure control strategy is a good candidate for separating the computational work load between a master processor and multiple parallel processors for low-level control. The anticipated division will allow the master processor to compute the joint angles and rotational velocities for a given command and the smaller processors will apply the feedback control for speed and position control.

#### 4.4.2 Communication of Data Signals

The necessity for communication is a consequence of the division of labor. The most significant consideration regards the method to transfer information across continuously rotating joints. The two solutions under consideration are using slip rings or wireless network hardware.



#### 4.4.3 Feedback

Classical control is used for the static and quasi-static modes to simplify implementation. Modern control will be used for the dynamically stable modes from the equations of motion. The current prototype only has rotary sensors and actuators to control the joints. Therefore, the only feedback that is possible (limited by observability) is spoke tip positioning and angular rotation speed control.

The intended assortment of sensors will also include contact sensing along the segment edges, force sensors at the spoke tips and accelerometers in the hub. These additional sensors will provide information that may be used for terrain mapping. While this level of sensing is not necessary for well-defined testing surfaces, these sensors will allow the feedback loops to be closed.

#### 4.4.4 Tolerances

The tolerances of programming include the processor speed and ability to correctly time events, the resolution of the analog to digital converter, the precision of variables and the error between assumed commands and actual values. The most significant source of error to address is the manufacturing tolerances of the actuators. The second greatest source of error comes from the resolution of the digital converter when reading analog sensors. The processor speed and precision of variables have not yet been evaluated as sources of error.

Seven motors were tested for consistency of speed when provided equivalent driving commands. Although close, the unloaded speed of the seven motors varied by

approximately 3%. If the speed control loop is not closed, the joint rotations may not behave as predicted.

The rotary sensors (analog potentiometers) are described by the manufacture as having infinite adjustability. However, discretization always provides a finite resolution when converted to a digital signal. The on-board 10 bit analog to digital converter provides approximately three distinct values per degree of rotation.

#### 4.5 Power

For safety when using experimental code, the power source is kept off-board within reach of the operator. The power source may either be a bench top DC power supply or high-capacity battery. While the voltage is regulated for the microprocessor by its own regulator and the current to the motors is regulated by the motor drivers, the voltage to the motors is not regulated. The power supply voltage must be carefully chosen for safe operation of the motors.

#### 4.6 Operation

The operation scheme allows the user to select a locomotion mode and specify the hub's movement vector only. There will be no user control of the individual spokes for the locomotion. However, spoke control may be available for manipulation.

##### 4.6.1 User Controls

The planned user controls include switching power, mode selection, ride height and a movement vector specification. Since the suspension is fully active, the Walk &

Roller will not be able to maintain its configuration without an adequate electrical power source. When powered down, the spokes will fold into a compact configuration. When powered up, the spokes will extend until contact with the surrounding terrain is made. The mode selection will allow the user to choose from the available locomotion modes. Specifying a motion vector will remain in two dimensions for the current prototype, but will apply to three dimensions when the first complete Walk & Roller is finished. The motion vector will provide a speed and relative direction command for the center of the body to seek.

Depending on the active mode, the direction control may be specified by one or two joysticks or set of buttons. In the case of rolling modes, it may be more familiar to the operator to use two joysticks that will allow the control of each hub independently like a track vehicle. For more autonomous modes such as vertical ascension, the control may be limited to one joystick or set of buttons to specify movements within the plane between surfaces.

#### 4.6.2 Automation

The planned autonomy is limited to spoke positioning and joint rotation only. Several processes such as the transition between locomotion modes or configurations will be handled without user commands.

#### 4.7 Modeling and Simulation

Several geometry models were developed to facilitate the motion planning algorithm. In addition to motion planning strategies, the torque calculations and

equations of motion were derived from the geometric models. Below are the descriptions of the simulations used to develop motion planning algorithms.

#### 4.7.1 Activation and Contact

The Walk & Roller is designed to fold back into the compact form when powered down. Upon restoring power, the Walk & Roller will first detect its orientation with respect to gravity then extend the spokes until making contact with nearby surfaces. The contact points will be evaluated for the resulting geometry. If the geometry does not provide a stable platform, the Walk & Roller will continue to retract and extend the relevant spoke(s) for varying joint rotation angles until a satisfactory configuration is found. Since the base is an equilateral triangle, one spoke will already be parallel and near the supporting surface. This bottom spoke may be used to flip the Walk & Roller over for a more preferable location or orientation.

In the simulation, this sequence is governed by joint rotational velocities and tip contact sensing only. The geometry is calculated from the provided angles for each time step.

#### 4.7.2 Rising to a Neutral Position

After the Walk & Roller finds a supportive platform, it will transition into one of the neutral positions described in section 2.1 as selected by the operator. The operator must also specify the ride height, which may be altered to avoid unnecessary contact with the surroundings. In the simulation, this sequence is governed by the hub's location and orientation for the initial and final geometries. The spoke tips are assumed not to move.

During each iteration, the joint angles are calculated from the known positions (the pivot joint positions are known from the hub location and rotation). The rates of rotation for all joints may be used from the simulation to assist the on-board microprocessor with prepared joint velocity values organized in a lookup table.

#### 4.7.3 2D Motion Cases

When both hubs are assumed to move in unison, the trajectory is assumed to be planar and the solution for one hub may be applied to the other. This simulation assumption may also apply to travel along a surface when turning. The details of the modes described in section 2.1 are all 2D cases. Parts of the simulation may use the locations of tips making contact as known. However, all locomotion modes operate with shifting support and discrete contact. The free spokes (unloaded or unresponsive of the Walk & Roller's weight) must be controlled by a different strategy. The current strategy employed uses the difference between the initial and final joint angles (from known and predicted geometries) and applies a constant joint rotational velocity through each time step. This strategy results in significant numerical error.

#### 4.7.4 3D Motion Cases

The two-dimensional motion cases are still in early development and it is assumed that adding another dimension will increase the simulation complexity. However, the additional complexity may only be mathematical in nature. Since motion in the third dimension relies on relative motions of the two hubs, the actual operation may be simple. The Walk & Roller may turn like a track vehicle if the hubs rotate at different relative

rates or in different directions. It may also turn like a cone rolls on a surface by producing a difference in ride height for each hub. These complex gaits have not yet been resolved.

The shaft ascension mode is of great interest to the Walk & Roller research. It is likely that a two dimensional model will not fully predict the behavior of this mode. A three dimensional model will include the cooperative sequence by which one hub provides support for the other to relocate its spoke contact. It has been predicted that five points of contact are sufficient and necessary. An accurate simulation should reveal if more or less supports are actually required. Additionally, the simulation process should facilitate testing of control algorithms for challenging three-dimensional terrains with varied widths and angles of inclination.

The Walk & Roller project is still in early stages of development. This section focuses on the intermediate results that lead to design reconsiderations. It is not yet possible to evaluate performance or test the initial hypotheses.

### 5.1 Things That Do and Do Not Work

The first prototype utilized worm gears. It was constructed to accommodate a variety of pitch sizes and gear ratios. The prototype demonstrated that worm gears were not preferable for this project.

The second prototype utilized MXL timing belts. The small belts (0.080" pitch) were easily destroyed during high torque conditions. Pololu's Baby Orangutans were used to provide inexpensive feedback control for the on-board motor drivers. The motor drivers were severely undersized for the application (manufacture's specifications were exaggerated). The Baby Orangutans were replaced with the more powerful Sabertooth motor drivers and feedback control was returned to the primary microprocessor.

The third prototype utilized XL timing belts (0.200" pitch). The weakest components in the current design are the motors. Although the motors are not capable of providing enough torque to the joints for lifting, this model is a suitable platform for testing motion planning and control algorithms. The model consists of one hub, three complete spokes and half of the body. The body is designed to provide a stable base such that the hub may operate parallel to the surface on which the body is resting.

## 5.2 Compare Simulation to Experiment

The Walk & Roller operation is designed to allow the user to specify a riding height and direction vector. The simulation use the hub's center as a reference to determine geometries that satisfy the desired commands. This functionality relies on knowledge or assumptions about the terrain and hub's orientation. However, in experimentation, the hub's position and orientation are not known. The on-board microprocessor must use terrain estimation and reverse kinematics. For consideration in which the joint angles are defined and the hub's angle and location is to be calculated, the simulation must have realistic constraints added to reproduce the trajectory defined by reverse kinematics. A full analysis of this comparison is not possible until both experimental and simulated approaches are more mature. However, the geometry is very well defined and may be evaluated to a limited extent.

### 5.2.1 Geometric Analysis For Various Modes

Geometrically, the model matches the prototype very well, they agree for prescribed lengths and relationships. The simulation correctly predicts joint angles required to maintain the desired hub paths, when the terrain is known. Unfortunately, the geometric constraints are not yet robust. Situations that would violate physics are still permitted by the model. For example, if the tip location is incorrectly specified, the model will allow spoke lengths to grow.



### 5.2.2 Predicting Forces and Required Torques

Maximum torques were calculated in section 3.2.3 for several configurations. Each mode presents a unique set of joint torque and control requirements. To choose the correct hardware, an estimation of the required torques is necessary. Additionally, each mode has an associated geometry for which one joint has a maximum torque requirement. The required joint torque may not correctly predict the necessary actuator performance as frictional and other losses have not been evaluated.

### 5.2.3 Accuracy of Model

The primary discrepancy between the model and the prototype is the thickness of spoke segments and the radius of the spoke tip. The simulations do not include modeled constraints. The simulations allow spoke parts to pass through the ground, walls, and each other. Additionally, the moving tip for contact sensing has not been included in the models.

The mass, mass distribution and moments of inertia have not been precisely accounted or implemented. The calculation of joint torques uses an estimated weight of each component, but they are treated as point masses in the geometric center of the respective part. Friction in the joints and drive system power losses have not been included in the models.

The dynamic model has equations of motion as derived from Lagrangian mechanics, but the constants and coefficients have not been resolved. This includes physical properties of all components as well as mechanical properties of the actuators.

When these parameters are included, the dynamic model should predict the changes in energy and momentum.

#### 5.2.4 Correctness of Assumptions

The most glaring error with the assumptions is that constant joint velocities could be used for joint rotations. This assumption may be valid for extremely small differences between initial and final angles. However, the on-board microprocessor will only be capable of performing calculations for relatively large time steps. The joint velocities are often nonlinear, they may even change sign during some motions. Therefore, either the Walk & Roller must creep along slowly with good joint velocity precision or the hub cannot follow a smooth trajectory.

#### 5.3 Effectiveness of Design

The current prototype has revealed that characterizing the dynamics, developing controls and evaluating performance does not require the construction of a complete vehicle or the full force of gravity. Due to the low output torque of the motors in hand, the current Walk & Roller prototype must be tested in a reduced gravitational environment to avoid stressing the hardware and allow for all desired joint rotations.

#### 5.4 Effectiveness of Controls

The initial feedback control algorithm for spoke tip positioning was a proportional integral controller. The proportional contribution was tuned to provide quick responses to reference commands. The integral control was tuned to eliminate steady state error.

The combination of friction in the joints and inertia of the hardware resulted in a gentle sway of the tip. The motor driver has to pass a threshold value in order to overcome the static friction and inertia. Once the integral term grows enough to provide a driving value above the threshold, the joint rotates toward the reference position. The integral term decays slowly and the joint overshoots by a small amount. Since the threshold value is related to the friction and inertia, the overshoot quickly reaches a steady-state limit cycle that repeats without end.

The problem cannot be solved by modifying the integral gain alone. There may have to be an additional test in the algorithm that can eliminate the windup excess.

#### 5.5 Effectiveness of Hardware

This research examines the sensor and actuator demands and performance required for desired behaviors. Since the primary actuators (motors) determine the speed and strength of the robot as well as the weight and size, there is an investigation for the optimal compromise of the design constraints. There is an interest in gaining such high speeds that the robot can enter a "gallop" mode such that only one spoke is in contact with the ground at a time while maintaining a stable ride height. There is a competing interest in providing such high torques that the robot can climb vertically within a shaft by shimmying against the walls.

#### 5.6 Effectiveness of Software

Computational expense is the primary concern for this section, but has not yet been evaluated. It is not practical to rely on the on-board microprocessor to calculate

joint angles for very small time steps. The following solutions are under consideration. A powerful computer may be used to prepare discrete sequences that may be called from a lookup table. However, this solution may not be effective for unmapped terrain. Another proposed solution reduces the increment between current positions and final positions such that joint velocities may be approximated by constant values.

### 6.1 Current progress Along Project Trajectory

The project trajectory has taken a couple of significant turns. The current design no longer fully resembles the inception. At the moment, the simulation and experimental portions of the research are still in the early stages of development. Many of the components and design elements have been tested independently. One spoke has been tested for positioning with a simple proportional integral feedback algorithm. The completed hub assembly with three spokes has not yet been tested.

The simulation has multiple programs to address the variety of design considerations and locomotion modes. There are two simulations that evaluate specified geometry for the necessary spoke requirements. There is one simulation to analyze the quasi-static Tumbleweed locomotion mode. The latter simulation simply provides a relationship between joint rotational velocities.

### 6.2 Performance of the Locomotive Modes

Testing the current prototype has not yet commenced. Simulation development suggests functionality is feasible, but requires greater on-board computational power and more torque from the actuators.

### 6.3 Advantages and Disadvantages of the Current Design

This section evaluates the consequences of design choices made to produce a working prototype. These decisions are not backed by investigation or optimization, but rather made from intuition.

#### 6.3.1 Dimensions Selected Without Any Specific Constraints

The most notable examples of this category are the spoke segment lengths and spoke base spacing. The dimensions were chosen to produce a compact scale while maintaining reaching abilities for the anticipated terrain types. The spoke segments were designed to have equal lengths with overlapping centers to simplify geometry and prevent unwanted extension or interference. It was assumed that equal spoke segments would result in greater symmetry and simplify some control strategies. The relationship between the pivot joint spacing and spoke segment lengths had to allow the upper segment to tuck into the hub with sufficient clearance for the adjacent joints. The widest tip to tip spacing (~28") was established as a convenient size to use. Finally, the dimensions were rounded to the nearest  $\frac{1}{2}$ " for ease of reference.

#### 6.3.2 Unanticipated Complications

As opposed to describing the manifestation of problems with the current design, this section presents complexities that were added from the development of a simple design idea. The best example is the moving spoke tip used for contact sensing. The idea was to allow a minor motion to provide information about the Walk & Roller's configuration and contact with terrain. However, experimentation showed the moving tip

contributed significant and unexpected movement that increased the overall degrees of freedom. The additional degrees of freedom and unexpected behavior both complicate the analysis and invalidate simplifying assumptions.

## 6.4 Unused Design Ideas

This section discusses the design ideas that were pursued through various stages of consideration and testing. Either CAD analysis or experimentation for each idea or implementation of a specific component or technology concluded the use was not beneficial or possible.

### 6.4.1 Worm Gear Transmission

Worm gears were initially selected to couple the motors to the revolute joints. The key benefits include large gear reduction ratios and anti-backdrivability. Eliminating backdrivability enables the joints to be held at a fixed rotation with the power off. The worm gears were tested and concluded to be disadvantageous to the vehicle's design. Backdrivability was accepted as a possible asset to facilitate active suspension schemes and give the vehicle "lively" movements.

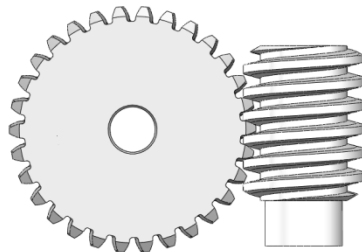

Figure 6.1: Worm gear set. Worm (right) drives worm gear (left).

As seen in Figure 6.1, the power transmission results from the worm thread rubbing the worm gear teeth. The system is not energy efficient. There is a 20%-40% loss of power depending on the quality of the worm gear sets and lubricants. High quality worm gear sets are very expensive.

Although the worm gears would produce large torques to the joints, the teeth must be able to handle the forces involved. The large (24 pitch) sets were strong enough, but the smaller (48 & 32 pitch) sets showed signs of damage after large loads were applied. Using the large pitch sets limits the transmission to relatively small gear ratios to avoid having large gears at the joints. To maintain a small moment of inertia for the hubs, the motors and other heavy components are kept near the hub's axis of rotation. Large gears required increased distances between the motors and the worms. Additionally, longer cantilevered shafts may bend easily and allow teeth to skip.

For the worm gears to operate correctly, the axes must be offset by half of the diametrical pitch. This distance results in large offsets from the joints and significant protrusions from the hub. The hub design must be much larger than is desirable to protect the gears and properly support the motor shafts. In addition to supporting the shaft on both sides of the worm, the shaft must be constrained from axial motions. Axial motions result in increased backlash. Unless protected from thrust forces, the axial forces on the worm impart on the motor shaft directly.

#### 6.4.2 Servo Drive

Servomotors offer the convenience of packaging all of the components necessary for precise positioning into a compact form. The motor, transmission, encoder and motor



driver with feedback control are all included. The major benefit is ease of operation. The major disadvantage is the limited installation options. Many servos lack strength in the output shaft and cannot be used as structural members. Structures that accommodate the servos tend to be bulky. Few servos can offer continuous rotation without disabling the positioning feedback control.

#### 6.4.3 Central Power

Direct current motors are used to actuate every joint for simplicity by design. Other power transmission options have been considered to produce a more compact or perhaps lighter form. One such idea which comes from the notion that not all joints require maximum torque simultaneously. It may be possible to use a central power supply instead. There are two common approaches to consider, hydraulic and pneumatic systems. Both systems may be pressurized by a single actuator and the high pressure fluid may be transmitted by a flexible connection to the joints to do work.

#### 6.4.4 Soft Pot Position Sensors

This passive analog electronic device provides information about the location of a contact force. The Soft Pot is simply a long narrow laminate of resistive elements that complete a circuit when pressed together. The substrate is a flexible plastic. The Walk & Roller was to make use of the Soft Pot for contact sensing along the lower segment edge. The design would use an 11" Soft Pot wrapped around tip and either side of the lower segment. Although flexible enough to wrap around a small diameter tip, the conductive

elements start to make contact for even a large radius of curvature. Since bending the component produces a signal, it cannot be used as intended.

#### 6.4.5 Absolute Digital Encoders

To gain the knowledge of absolute rotation at the joints, compact hollow shaft potentiometers are used. The two greatest problems with the analog devices are the incomplete electrical contact and limited resolution. Unfortunately, the dead zone of the potentiometers leaves a small sector unobservable. Fortunately, the resolution can be improved by employing a better analog to digital converter. Optical digital encoders are capable of providing absolute angles at high resolutions for full circles. However, absolute digital encoders are much bigger than the potentiometers, very expensive and require one digital signal connection for each bit of resolution. The current microprocessor would not be able to accommodate the requirements.

Magnetic encoders offer similar functionality as the optical digital encoders in a very compact and inexpensive package. The magnetic encoders we evaluated have the option of providing an analog signal or digital output as a serial communication. While the magnetic encoders offer substantial functionality, the implementation is not trivial. The minuscule integrated circuit encoder must be attached to a carrier and programmed for use. It is preferable to use such a component when other design elements are resolved.

#### 6.4.6 Strain Gauges

In section 4.2.4, the contact sensing tip is described as introducing undesirable movements. Another tip design makes use of coupled cantilever beams that would bend in such a way that attached strain gauges could detect the direction and magnitude of load forces.

#### 6.4.7 Force Sensors

An alternative design for the moving tip problem is a pair of force sensors attached to orthogonal planes that are activated by an elastic cylinder. Preliminary tests indicate that the force sensors correctly predict the direction and magnitude of load forces without moving a significant amount. Designs to implement the force sensors in the spoke tip are still in development.

#### 6.4.8 Baby Orangutans

A baby orangutan is a very small, inexpensive microprocessor capable of feedback control via analog or digital inputs and on-board motor driver. The Baby Orangutan takes the burden of low-level feedback control for positioning off of the main microprocessor. The Baby Orangutans were not used due to the severely underpowered on-board motor drivers. However, the division of labor has potential and other motor controllers should be evaluated.

#### 6.4.9 MXL Size Timing Belts

The MXL series has teeth that are 0.018" tall, 0.054" long and 0.080" apart. The width of the teeth depend on the width of the belts. The narrowest belts (0.125") were tested first to determine how compact the drive system could be made. These belts failed in several modes.

One mode of failure was the skipping teeth. As the torque increased above a certain threshold, the belt lost engagement with the pulleys. This failure happened for small and medium size pulleys. Another failure was the shearing off of the belt teeth. The bases' cross-sectional area is very small and when wrapped around the smaller pulleys, the force per tooth can be very large. The final failure mode was the disengaging of the rubber from the reinforcing (Kevlar or fiberglass) cords.

While increasing the tension of the belt reduced skipping, it also increased the disengaging of the rubber from cords. The only system that performed well was between two large pulleys. When using two pulleys of nearly the same size, the gear ratio is near 1:1 and the benefit of using a fine pitch timing belt is defeated. The proposed solution was to use a wider timing belt (0.187"), smaller gear ratios and a tension as large as safely possible. However, before these changes could be tested, the XL size timing belt system was implemented.

#### 6.4.10 Spinners

The current prototype design has the option to add an actuator and inertial mass to the center of each hub. This mass may be spun up or down to modify the vehicle's

angular momentum. The spinner functionality may improve balance in unstable modes or raise the maximum speed of rotation to enhance travel velocity.

#### 6.4.11 Slip Rings

Slip rings provide a connection for electric circuits across continuously rotating joints. The lower spoke segments are designed to rotate continuously and provide sensor information from the spoke tip to the microprocessor. The slip ring design considered here consist of a stack of circular contacts adhered to the middle joint shaft and a set of spring loaded brushes mounted to the upper segment. The initial design is no longer compatible with the current hardware and the current design has not been fabricated. The slip rings will be used in the middle joint application. The two hubs will be separated by a continuously rotating joint on the final Walk & Roller. One proposed solution uses slip rings, but another takes advantage of the independent power sources and microprocessors to use a wireless connection.

#### 6.4.11 Vacuum Cups

Vacuum cups resemble ordinary suction cups, but have superior holding power on smooth surfaces. They feature an outlet port to allow continuous suction by an active vacuum source (fluid sink). The holding power is related to the cup's area and difference in pressure on either sides of the cup wall. Vacuum cups could enable the Walk & Roller to free climb on smooth surfaces. To function properly, the system would require an actuator to draw a low-pressure vacuum and actuators to operate valves for each spoke tip. Due to the additional complexity, vacuum cups have not been tested.

## 6.5 Untested Claims

It may be possible to produce a larger version using the same geometry by accounting for the differences in masses, joint torques, inertias and time scales.

## 6.6 Suggestions for Future Work

Designing the prototype to be as compact as possible was a disadvantageous design approach. A better approach would use the geometry model and estimated masses first to determine the necessary actuators and transmission components. The current hardware is unable to satisfy the minimum torque requirements as displayed in section 3.2.3 without significant gear reduction. It would be beneficial to redesign the hub and body to accommodate more powerful motors. Using the MatLab code for determining approximate torques, new motors could be selected to provide the necessary maximum values.

The motors are not necessarily the weakest part of the design. The MXL timing belts failed under modest loads. The XL size belts should be tested for performance at the maximum loading possible. Additionally, the transmission components should be spaced correctly for the timing belts that are employed. The current prototype was designed for 1/8" wide belts. Fortunately, the design was flexible enough to allow the use of 3/16" wide belts. Since the belt strength is proportional to the width, the next design should accommodate wider belts.

Although the CAD model was exceptional at predicting fit, clearances and alignment of the drawn components, it was easy to neglect the elements that were not

included. Wiring the electronics takes up a lot of space and wire routing is sensitive to twists, turns and moving parts. Several connections have been broken due to the implementation of undersized wires selected for fit through narrow passages or other physical constraints. The next design should include more room for routing wires and improved paths to protect wires from moving parts. The structural components should provide securing points for strain relief and to minimize flexing or extraneous movement.

The current prototype uses PTFE bushings and quality lubricant exclusively for revolute joints. To continue using bushings, a compromise must be made between using a durable material or using a low friction material. If higher-torque actuators are implemented, perhaps custom bushings that are designed for durability are the better choice. The recommendation here is to redesign the joints to make them compatible with standard ball bearings. Whether bushings or bearings are used, the joint friction should be characterized for the torque calculation and positioning control strategies.

As described in section 6.3.2, the moving spoke tip designed for contact sensing led to undesirable effects. In order for the Walk & Roller to perform well on varied terrain, the spokes must be able to detect contact vectors. The more observable are the spokes, the better the terrain estimation. It is advisable to make all surfaces of the lower segment and some portions of the upper segment able to detect contact. However, it is of interest to maintain a simple design without moving parts that is light weight and does not require many signals to be passed through the continuously rotating joint.

## PART 2: iFling - The Two-Wheeled Ball Pickup, Storage and Flinging RC Toy

### Chapter 7 Mechanical Design of the iFling

#### 7.1 Introduction

The iFling is a small radio-controlled toy capable of self-balancing using active feedback controls, ball pickup and throwing. The robot consists of circular body with a diameter and a width of approximately three times the intended ball diameter. The current iFling is designed for 40mm ping pong balls. The robot has two coaxial wheels which provide great agility and entertaining inverted pendulum style motions. The center of gravity is above the axis of rotation so that when turned off, the robot falls over.

The vertical arm is designed as a track for throwing a ball and as a mass to enable forward and backward motions. When the robot leans forward, it moves forward to restore vertical balancing. Backward motion is the same. Turning is facilitated by rotating the wheels in opposite directions.

The feedback controls used for self-balancing relies on comparing the signals of two MEMS accelerometers. One is located near the axis, the other is located on the platform near the top of the throwing arm. The vertical stabilization feedback control may be turned off to allow a horizontal operation with the throwing arm dragging. The horizontal mode is necessary to initiate a throw.



### 7.1.1 Project History

The iFling robot program started several years ago to develop a highly agile radio controlled toy car capable of throwing a ball. The previous iFling design was successful in upright maneuverability and ball tossing.

Despite early success with stabilization and throwing, there was no mechanism to automatically pickup, store or load the balls. The ball toss was performed in a catapult style lobbing that was limited to a short distance.

### 7.1.2 Project Goals

The goal was to produce a working prototype of a self-contained iFling concept that could perform well in all the described modes. The measure of success was based on the performance of the added functionality and polished aesthetics.

### 7.1.3 Problems to Address

The primary design problem to address was maximizing functionality and performance while minimizing size and cost. The current design increased functionality, size and cost, but did not increase performance. The desired functions which would make the iFling more self-contained would also add more weight, bulkiness, complexity and cost. There are additional considerations discussed in the next sections.

## 7.2 Design Constraints

A standard 40mm ping-pong ball established the size requirement. The width had to allow the passage of the ball through three nonintersecting channels. The diameter had

to accommodate a circular channel and all the hardware but remain small enough to provide ball pickup.

Other components that affected design include the printed circuit board, which is relatively large and had to be oriented vertically for the accelerometer to function correctly. Additionally, the batteries had to be accessible and removable.

### 7.2.1 Vertical Balance Mode

The vertical balance mode behaves like an inverted pendulum with a non-minimum phase swing up process. The iFling must have the center of gravity high enough to allow significant forward motion with a minimal forward lean to allow for ball pickup to function correctly. It performs best (most responsive to commands) when the center of gravity is far above the axis of rotation. The iFling achieves greater acceleration and turning rates when the wheels have a small mass relative to the body.

### 7.2.2 Rover Mode

To conserve cost and limit complexity, the two independent drive motors were neither calibrated nor speed controlled. The directional bias that resulted from unmatched motor performance is amplified while pushing the heavy throwing arm across the ground. Conversely, dragging the throwing arm behaves like a vane which reduces the steering bias.

Like the vertical balance mode, the rover mode performs best when the center of gravity is far from the axis of rotation. The operator's control improves when the throwing arm is in contact with the ground.

### 7.2.3 Flinging Mode

Throwing is accomplished by rapidly rotating the body and fixed throwing arm relative to the ground. This action performs best when the mass and inertia of the body is much smaller than the wheels'. The rotation is enhance by moving the center of gravity below the axis of rotation (i.e. below when in vertical mode).

### 7.2.4 Compromises Between the Three Modes

The design considerations that promote flinging also inhibit vertically balanced operation and vice versa. Rover mode is not strongly affected by the preferences of the other modes. Without the ability to dynamically modify the center of gravity's location or wheel mass, the iFling design must accept a performance compromise of the varied modes.

The current body design favors flinging by having a low center of gravity. There is a mount above the body for a removable mass to assist the vertical performance. The wheels have small masses which favor acceleration while driving over flinging.

## 7.3 Theoretical Considerations

By the conservation of angular momentum around the robot's center of gravity, the throw is performed by rapid reverse acceleration of the wheels. As the body moves backwards, the throwing arm quickly rotates up and forward. The body's rate of rotation and therefore, the throw, is inversely related to the magnitude of the moment of inertia.

The throwing motion provides the ball with a forward velocity, relative to the ground. Since the ball rolls along the track rather than sliding, the track imparts a spin on the ball which improves the flight stability and effective range.

#### 7.4 Design of Mechanisms

The current iFling design utilizes three novel mechanisms for ball handling; pickup, storage and release. Each mechanism solves a unique challenge of working reliably with varied ball diameters. The designs focus on using current robot operation to achieve the desired effect with passive components when possible. The ball release mechanism had to be operated by an actuator to allow the microcontroller to control timing.

##### 7.4.1 Ball Pickup

The Ball Pickup Mechanism consists of a circular channel formed between the body and the wheels. The robot has two coaxial wheels and therefore two pickup channels. The body has a scooped contour to encourage a ball toward one of the pickup channels. The wheels have compressible foam inserts or spring loaded tracks to apply pressure on the ball for reliable conveyance. The robot must roll forward, within a range of angles relative to the ground, to successfully pickup a ball.

##### 7.4.2 Ball Storage

When the wheel holding a ball rotates forward (relative to the body) the ball rolls along the channel toward the storage basket. Since the robot may turn like a treaded

vehicle, ball pickup is possible even when the robot spins in place. Each channel has a spring loaded flipper to prevent the ball from leaving the storage basket through the pickup channel.

### 7.4.3 Ball Release

The ball release mechanism consists of a molded plastic gate actuated by a RC servo via a rigid steel rod. The spherical portion of the gate matches the exterior dimensions of a 40mm ping pong ball. The arc length or angle of the gate is large enough to prevent passage of multiple balls, while small enough to minimize servo movement and release time.

When the robot is vertical, the ball release mechanism is closed to prevent balls from jumping out of the basket. The shape of the gate allows a single ball to sit at the base of the throwing arm track while the robot is upright. The basket has a sloped contour to encourage a ball toward the track. When the robot is horizontal, the Ball Release Mechanism stays closed to prevent balls from rolling out of the basket. When the throw is triggered by the user, the ball release mechanism momentarily opens to allow one ball to roll onto the throwing arm track. Throwing is an open-loop control process timed by the microprocessor.

## 7.5 Development and Implementation

The development of the iFling's new functionality was an iterative process. Initial sketches for the ball release and Jai Alai style throwing arm were composed for the ping

pong ball scale. Foam board models were constructed to test the various design ideas. Open-cell foam and a parallel track were added to the wheels to develop the ball pickup mechanism. The ball pickup design established a beginning scale within which all other components had to fit.

The new dimensions, which are significantly larger than the original design, provided a platform for which the ball storage container could be attached.

## 7.6 Conclusion

The ball pickup, storage and release work very well. When a ball is rolled over, it is picked up and transported to the storage basket. Balls that enter the basket do not fall out even during the most violent operation. The release mechanism (which is controlled by a timer) successfully ejects individual balls on demand.

The flinging does not work well. The rotation is so slow that the ball drops vertically faster than the desired horizontal translation. When very heavy wheels are used, the body's rotation is significantly faster. The solution is a redesign that reduces the body's mass and rotational inertia.

The current design favors flinging, so the design criteria that promote vertically balanced operation are reduced. The current iFling must lean over very far to achieve full speeds which inhibit ball pickup at all but the slowest speeds.

The current design suffers from overly slippery surfaces. This is due to the 3D printing process and use of ABS for the primary structure. The ABS is a slippery material which reduces friction and gripping. Attempts have been made to improve

traction between the wheels and the ground, between the ball and channels, and between the ball and throwing arm.

## References

- [1] T. Fukuda, T. Aoyama, Y. Hasegawa and K. Sekiyama. 2009. Multilocomotion Robot: Novel Concept, Mechanism, and Control of Bio-inspired Robot. *Artificial Life Models in Hardware*. Springer London. Pages 65-86.
- [2] H. C. H. Chiu, M. Rubenstein and W.M. Shen. 2009. Deformable Wheel: A Self-Recovering Modular Rolling Track. *Distributed Autonomous Robotic Systems 8*. Pages 429-440.
- [3] P. Ren. 2010. Kinematics Analysis of Two Parallel Locomotion Mechanisms. Virginia Polytechnic Institute and State University Dissertation. ETD: 09082010-153139. Pages 75-142.
- [4] W. H. Lee and A. Sanderson. 2002. Dynamic Rolling Locomotion and Control of Modular Robots. *Robotics and Automation, IEEE Transactions on*. Vol. 18. Pages 32–41.
- [5] J. Sastra, S. Chitta, and M. Yim. 2006. Dynamic Rolling for a Modular Loop Robot. *International Symposium on Experimental Robotics*. Vol. 28. Pages 758-773.
- [6] F. Pfeiffer, T. Rossmann, K. Löffler. 2000. Control of a tube crawling machine. *Control of Oscillations and Chaos*, 2000 IEEE International Conference on. Vol. 3. Pages 568-591.
- [7] W. Neubauer. 1994. A spider-like robot that climbs vertically in ducts or pipes. *Intelligent and Robotic Systems*, 1994 IEEE International Conference on. Vol. 2. Pages 1178-1185.
- [8] M. F. Silva and J.A. T. Machado. 2007. A Historical Perspective of Legged Robots. *Journal of Vibration and Control*. Vol. 13. Pages 1447-1486.
- [9] F. Michaud, D. Létourneau M. Arsenault, Y. Bergeron, R. Cadrin, F. Gagnon, M.A. Legault, M. Millette, J.F. Paré, M.C. Tremblay, P. Lepage, Y. Morin, J. Bisson and S. Caron. 2005. Multi-Modal Locomotion Robotic Platform Using Leg-Track-Wheel Articulations. *Autonomous Robots*. Vol. 18. Pages 137-156.
- [10] E. Garcia, J. A. Galvez and P. Gonzalez De Santos. 2003. On Finding the Relevant Dynamics for Model-Based Controlling Walking Robots. *Journal of Intelligent and Robotic Systems*. Vol. 37. Pages 375–398.
- [11] J. Park. 2010. The Relationship Between Controlled Joint Torque and End-Effector Force In Underactuated Robotic Systems. *Robotica*. Cambridge Journal Online.



- [12] O. Khatib, P. Thaulad, T. Yoshikawa, J. Park. 2008. Torque-Position Transformer For Task Control of Position Controlled Robots. *Robotics and Automation, 2008 IEEE International Conference on*. Pages 1729-1734.
- [13] M. Zribi, H. Loulin and C. S. Piu. 1999. Position and Force Control of Two Constrained Robotic Manipulators. *Journal of Intelligent and Robotic Systems*. Vol. 24. Pages 1-22.
- [14] K. Kozłowski, P. Herman. 2008. Control of Robot Manipulators in Terms of Quasi-Velocities. *Journal of Intelligent and Robotic Systems*. Vol. 53. Pages 205-221.
- [15] M. Galicki. 2005. Control-Based Solution to Inverse Kinematics for Mobile Manipulators Using Penalty Functions. *Journal of Intelligent and Robotic Systems*. Vol. 42. Pages 213-238.
- [16] T. Bretl. 2006. Motion Planning of Multi-Limbed Robots Subject to Equilibrium Constraints: The Free-Climbing Robot Problem. *The International Journal of Robotics Research*. Vol. 25. Pages 317-342.
- [17] A. S. Boxerbaum, J. Oro, G. Peterson, R. D. Quinn. 2008. The Latest Generation Whegs™ Robot Features a Passive-Compliant Body Joint. *Intelligent Robots and Systems, 2008 IEEE International Conference on*. Pages 1636-1641.
- [18] K. A. Daltorio, T. E. Wei, S. N. Gorb, R. E. Ritzmann, R. D. Quinn. 2007. Passive Foot Design and Contact Area Analysis for Climbing Mini-Whegs. *Robotics and Automation, 2007 IEEE International Conference on*. Pages 1274 - 1279.
- [19] O. Unver and M. Sitti. 2010. Tankbot: A Palm-size, Tank-like Climbing Robot using Soft Elastomer Adhesive Treads. *The International Journal of Robotics Research*. Vol. 29. Pages 1761-1777.