

Lawrence Berkeley National Laboratory

Recent Work

Title

The U5.0 Undulator for the ALS

Permalink

<https://escholarship.org/uc/item/8vv5s2c2>

Authors

Hoyer, E.
Chin, J.
Halbach, K.
et al.

Publication Date

1991-07-01



Lawrence Berkeley Laboratory

UNIVERSITY OF CALIFORNIA

Accelerator & Fusion Research Division

Presented at the 4th International Conference on Synchrotron Radiation
Instrumentation, Chester, United Kingdom, July 14-19, 1991,
and to be published in the Proceedings

The U5.0 Undulator for the ALS

E. Hoyer, J. Chin, K. Halbach, W.V. Hassenzahl, D. Humphries,
B. Kincaid, H. Lancaster, and D. Plate

July 1991

*U. C. Lawrence Berkeley Laboratory
Library, Berkeley*

FOR REFERENCE

Not to be taken from this room

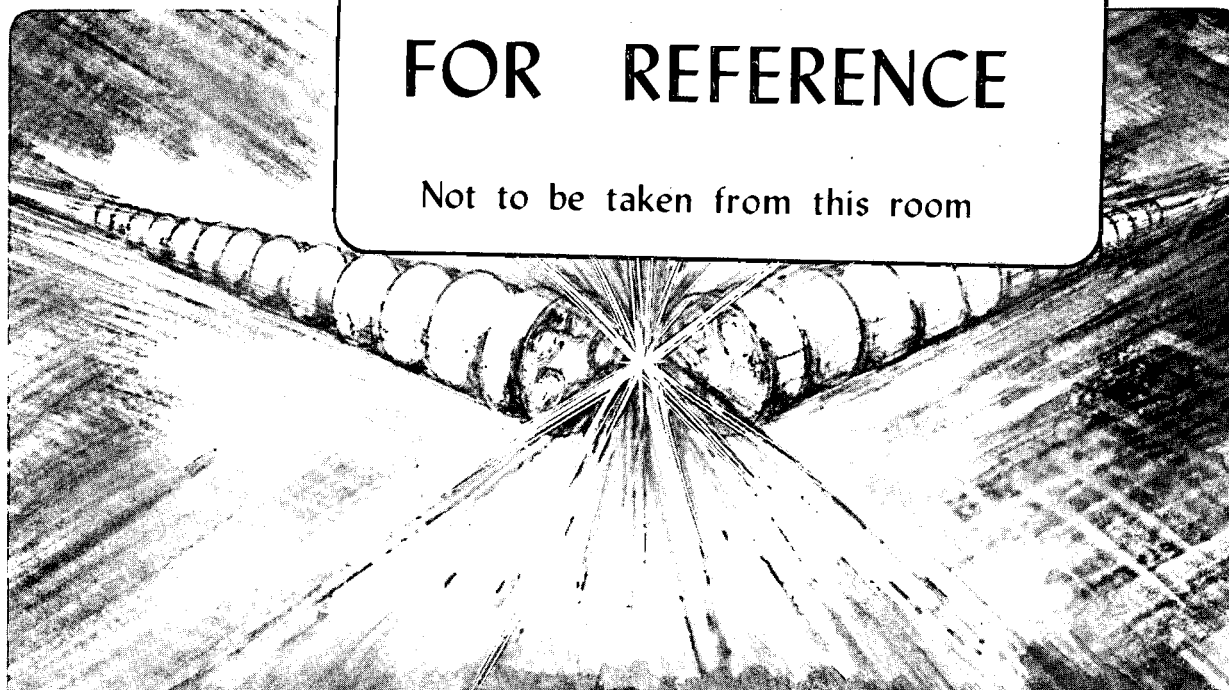

DISCLAIMER

This document was prepared as an account of work sponsored by the United States Government. Neither the United States Government nor any agency thereof, nor The Regents of the University of California, nor any of their employees, makes any warranty, express or implied, or assumes any legal liability or responsibility for the accuracy, completeness, or usefulness of any information, apparatus, product, or process disclosed, or represents that its use would not infringe privately owned rights. Reference herein to any specific commercial product, process, or service by its trade name, trademark, manufacturer, or otherwise, does not necessarily constitute or imply its endorsement, recommendation, or favoring by the United States Government or any agency thereof, or The Regents of the University of California. The views and opinions of authors expressed herein do not necessarily state or reflect those of the United States Government or any agency thereof or The Regents of the University of California and shall not be used for advertising or product endorsement purposes.

Lawrence Berkeley Laboratory is an equal opportunity employer.

DISCLAIMER

This document was prepared as an account of work sponsored by the United States Government. While this document is believed to contain correct information, neither the United States Government nor any agency thereof, nor the Regents of the University of California, nor any of their employees, makes any warranty, express or implied, or assumes any legal responsibility for the accuracy, completeness, or usefulness of any information, apparatus, product, or process disclosed, or represents that its use would not infringe privately owned rights. Reference herein to any specific commercial product, process, or service by its trade name, trademark, manufacturer, or otherwise, does not necessarily constitute or imply its endorsement, recommendation, or favoring by the United States Government or any agency thereof, or the Regents of the University of California. The views and opinions of authors expressed herein do not necessarily state or reflect those of the United States Government or any agency thereof or the Regents of the University of California.

THE U5.0 UNDULATOR FOR THE ALS*

E. Hoyer, J. Chin, K. Halbach, W.V. Hassenzahl, D. Humphries, B. Kincaid,
H. Landcaster, and D. Plate

Advanced Light Source
Accelerator and Fusion Research Division
Lawrence Berkeley Laboratory
University of California
Berkeley, CA 94720

July 15, 1991

This report has been reproduced directly from the best available copy.

Paper Presented at the 4th International Conference on Synchrotron Radiation Instrumentation,
Chester, United Kingdom, July 15-19, 1991

*This work was supported by the Director, Office of Energy Research, Office of Basic Energy Sciences, Materials Sciences Division of the U.S. Department of Energy, under Contract No. DE-AC03-76SF00098

THE U5.0 UNDULATOR FOR THE ALS*

E. Hoyer, J. Chin, K. Halbach, W.V. Hassenzahl,
D. Humphries, B. Kincaid, H. Lancaster, and D. Plate

Accelerator and Fusion Research Division
Lawrence Berkeley Laboratory, University of California
Berkeley, California 94720, USA

Abstract

The U5.0 Undulator, an 89 period, 5 cm period length, 4.6 m long insertion device has been designed, is being fabricated and is scheduled for completion in early 1992. This undulator will be the first high brightness source, in the 50 to 1,500 eV range, for the Advanced Light Source (ALS) at the Lawrence Berkeley Laboratory.

A hybrid magnetic configuration using Nd-Fe-B permanent magnet material and vanadium permendur poles has been selected to achieve the field quality needed to meet performance requirements. The magnetic structure is modular with each half consisting of 5 assembly sections, which provide the periodic structure, and end structures, for entrance and exit correction, mounted on a steel backing beam. Each assembly section consists of 35 half-period pole assemblies bolted to a mount. The required 0.837 Tesla effective peak field at a 1.4 cm gap has been verified with model measurements. Vertical field integral correction is accomplished with the end structures, each having an

arrangement of permanent magnet rotors which will be adjusted to minimize electron beam missteering over the undulator operating field range. To reduce the effect of environmental fields, the steel backing beams are connected through parallel, low-reluctance, Ni-Fe hinges.

The magnetic structure is connected through four roller-nuts to the drive system that provides gap adjustment with an arrangement of roller screws, chain drives, a gear reduction unit and a stepper motor driven by a closed loop control system. Magnetic structure and drive system support are from a 2.4 m high structure which includes a support base with four vertical supports.

The vacuum chamber design is a two-piece machined and welded 5083-H321 aluminum construction of 5.1 m length. Pumping is with a combination of ion, TSP and NEG pumps.

Magnetic design, subsystem design and fabrication progress are presented.

I. INTRODUCTION

The Advanced Light Source (ALS), a third generation synchrotron radiation source, is currently under construction at the Lawrence Berkeley Laboratory.¹ This facility consists of a 50 MeV linac, a 1 Hz, 1.5 GeV booster synchrotron and a low-emittance electron storage ring optimized for the use of insertion devices at 1.5 GeV. The use of insertion devices in the storage ring will produce high brightness beams in the UV to soft X-ray range.

The U5.0 Undulator will be the first high brightness source in the 50 to 1,500 eV range. It is scheduled for completion in 1992. To achieve high brightness, the U5.0 undulator design must meet the stringent requirements given in Tables I and II, derived from the need for rapid scanning of narrow spectral features and the need to avoid perturbing the electron beam in the storage ring.²

The engineering parameters, shown in Table III for the U5.0 Undulator, are derived from operating constraints and spectral and storage-ring requirements. Figure 1 shows an end view of the U5.0 Undulator with most major subsystems identified.

II. MAGNETIC STRUCTURE

The magnetic structure provides the required magnetic fields and includes the periodic-magnetic structure, end-magnetic structures, backing beams, low-reluctance hinges and, if required, auxiliary-tuning coils.

The ALS insertion devices incorporate hybrid magnetic configurations consisting of Nd-Fe-B magnetic blocks and vanadium permendur poles. The hybrid design was chosen because there are several advantages over the pure current sheet equivalent material (CSEM) design.³

- Fields are dominated by the characteristics of the poles, which can be made very uniform both in size and magnetic performance.
- Errors in magnetic moments of the blocks can be averaged by sorting the blocks for the poles.
- Errors in total magnetic moment of all the blocks for the pole have little effect on the electron beam, or the spectrum, because they contribute equally to adjacent poles and produce no electron steering.
- A higher peak field is achievable.

For undulators, the objective of the magnetic design is to develop a magnetically well behaved structure which yields a high value of B_{eff} for mid-plane fields. B_{eff} is given by

$$B_{\text{eff}}^2 = \sum_{i=0}^{\infty} \left(\frac{B_{2i+1}}{2i+1} \right)^2 \quad (1)$$

where B_1 is the amplitude of the fundamental, B_3 is the amplitude of the third harmonic, etc.

The magnetic configuration is based on 2-D modeling with the computer code PANDIRA and a 3-D Hybrid theory for hybrid CSEM insertion devices.^{4,5} To verify the magnetic design for U5.0, a model was built and tested under a variety of conditions.⁶ The undulator performance criteria are met

by tolerances based on the hybrid CSEM insertion device theory. The tolerances established for U5.0 are given in Table IV.⁷

Figure 2 shows the U5.0 magnetic structure, which is made of: a) half-period pole assemblies, that include an aluminum keeper, a vanadium permendur pole pinned into the keeper and six Nd-Fe-B blocks (3.5 cm square by 1.7 cm thick in the magnetization direction) bonded into the assembly⁸ (this design allows for accurate vertical and longitudinal pole tip placement); b) assembly sections that consist of an aluminum pole mount onto which 35 half-period pole assemblies are mounted and accurately positioned; c) stress relieved steel backing beams that are 4.5 m long, 81 cm deep, and 89 cm wide⁹ (each beam provides magnetic shielding and holds five assembly sections and two end sections); and d) dipole and steering coils, if needed.

The upper and lower backing beams are tied together with low reluctance Ni-Fe linkages to reduce the effect of environmental fields on the electron beam trajectory.¹⁰

To avoid steering the beam as it travels through the insertion device, it is necessary to control the configuration of the fields at the ends. Figure 3 shows the end magnetic structure that utilizes a system of Nd-Fe-B rotors to fine-tune the fields at the ends of the insertion device. There are four rotors at each end, and a fixed quantity of Nd-Fe-B at each rotor location. In the absence of significant gap-dependent field errors in the periodic structure, a single set of orientations for the rotors should minimize steering over the entire range of gaps.

Magnetic structure design is complete, parts fabrication is well along and bonding of the Nd-Fe-B blocks into the keepers has begun.

III. SUPPORT AND DRIVE SYSTEMS

The support and drive systems include the support structure that provides the framework for holding the magnetic structure and the drive system that opens and closes the magnetic gap. Requirements for the support structure include: supporting a maximum magnetic load of 84,000 lb; maintaining a magnetic gap variation of 58 μm at the smallest gap (14 mm); meeting the ALS storage ring, tunnel and adjacent beamlines space requirements; accommodating the vacuum system and its support structure; and, being capable of installation, alignment and servicing in the storage ring.

The support structure is of rigid construction consisting of a base onto which two lower horizontal members are mounted. Four vertical posts are in turn attached to the lower horizontal members and the two upper horizontal members are attached to the tops of these posts. The four horizontal beams pass thru the webs of the backing beams to limit the overall height of the support structure to less than the 8 ft tunnel height.

A magnetic-load compensating spring system is provided to counteract the gap-dependent magnetic load.¹¹ Each of the eight spring assemblies consist of two helical compression springs connected in series to match the gap dependent

magnetic load to within 20%. Benefits of the compensating springs include: reduced system friction which gives better positional response from the drive system over the life of the device, minimum motor load holding torque at any magnet gap required which gives stationary stability when the null position is reached, motor current can be turned off or reduce to minimize motor heating, elimination of "lifting" when the magnetic load exceeds the gravitational beam weight of the lower-backing beam, and reduced structure load which gives better gap reproducibility.

The drive system requirements are set by the spectral requirements and include: the capability of opening the magnetic gap with an 84,000 lb magnetic load; a step resolution of 1 μm ; a maximum scanning speed of 2.3 mm/s; a magnetic gap range of 1.4 cm to 21.6 cm; an opening or closing time of five minutes or less and determination of gap position by an absolute encoder.

Changing the magnet gap in an insertion device requires moving the backing beams. This is accomplished by rotating the 2 mm pitch Transrol roller screws that are mounted to the horizontal beams and that support the backing beams. Specifically, the four right-handed roller screws attach to the upper backing beam and the four left-handed roller screws attach to the lower backing beam. They are connected by a shaft coupling and combine to provide equal and opposite vertical motion when rotated. Gap motion is provided by the rotation of a stepper motor which is transmitted through a gear box and a series of sprocket wheels and roller chains to the roller screws. An absolute rotary encoder is coupled to

one of the Transrol roller screw shafts to read the absolute position of the magnet gap.

Analysis of the proposed system shows that stick-slip will give a gap uncertainty of less than $0.4 \mu\text{m}$.¹² Backlash is estimated at 87 mm in gap motion, which requires unidirectional scanning and control of the undulator gap. Scan-to-scan gap reproducibility for unidirectional scanning is estimated to be less than $8 \mu\text{m}$.

Undulator temperature control is important. A vertical temperature gradient of greater than 0.1 degree C in the undulator backing beams produces excessive spectral broadening. The U5.0 Undulator will have an enclosure, and the temperature in the enclosure will be maintained by circulating the air.

The support and drive systems design and component fabrication is complete and assembly is underway.

IV. CONTROL SYSTEM

The insertion device control systems are designed to provide sufficient position accuracy, resolution, velocity and range information for the motors and encoders for all anticipated insertion devices. In addition, the control system must control and monitor the dipole and steering correction power supplies, as well as controlling gap dependent rotator positioning, if required. The insertion device control systems are to be integrated into the overall accelerator computer control system.

A Compumotor system has been selected for the gap control and is currently undergoing tests.

V. VACUUM SYSTEM

The objective of the vacuum system is to provide a 10^{-9} Torr vacuum at the insertion device beam aperture. Figure 4 shows a plan view of an undulator vacuum system. Two vacuum chambers are required for ALS operation, one for commissioning and one for dedicated operation.¹³ The commissioning chamber has an elliptical beam aperture of dimensions 1.8 cm vertical x 6.2 cm horizontal. The chamber for dedicated operation has a rectangular beam aperture of dimensions 1.0 cm vertical x 6.2 cm horizontal.

The 5.1 m long undulator vacuum chambers will be made of two pieces of machined 5083-H321 aluminum alloy. Both chambers have a total horizontal aperture of 21.8 cm, the inner 6.2 cm provides the circulating beam aperture and the outer aperture allows the bending-magnet synchrotron radiation to pass through the chamber. The radiation is then absorbed by the photon stop located at the exit end of the chamber. External surfaces of the chambers have pockets machined into them for the magnet poles. The shape allows a minimum magnetic gap of 2.2 cm for commissioning and 1.4 cm for dedicated operation.

The vacuum system consists of six combination 600 l/s titanium sublimation and 60 l/s ion pumps (which give a net pumping speed of 173 l/s each at the antechamber) and an ALS absorber pump of 1450 l/s capacity giving a total

antechamber pumping speed of 2500 l/s. The average pressure distribution at the beam aperture is estimated at 3×10^{-10} Torr, assuming 40 Ampere hours of accumulated electron beam operation with a thermal outgassing rate of 10^{-11} Torr l/s cm^2 and a molecular production rate, due to photon induced desorption of 10^{-5} molecules/photon (for photons of energies greater than 10 eV) and for 1.9 GeV—400 mA storage ring operation.¹⁴

Vacuum system design has been completed and fabrication is due to start shortly.

VI. ACKNOWLEDGMENT

*This work was supported by the Director, Office of Energy Research, Office of Basic Energy Sciences, Materials Sciences Division of the U.S. Department of Energy, under Contract No. DE-AC03-76SF00098.

VII. REFERENCES

1. "1-2 GeV Synchrotron Radiation Source," LBL PUB-5172, Rev. (July 1986)
2. "U5.0 Undulator Conceptual Design Report," LBL PUB-5256 (November 1989).
3. W.V. Hassenzahl, et al., "Insertion Devices for the ALS at LBL," IEEE Particle Accelerator Conference, 89CH2669-0, Page 1222 (March 1989).
4. K. Halbach, et al., developed PANDIRA, an improved version of POISSON which allows solution of permanent magnet and residual field problems; POISSON is an improved version of TRIM [A. Winslow, J. Computer Phys. 1, 149 (1967)].

5. K. Halbach, "Insertion device Design: 16 Lectures Presented from October 1988 to March 1989," LBL Publication V 8811-1.1-16.
6. W.V. Hassenzahl, E. Hoyer, and R. Savoy, "Design and Test of a Model Pole for the ALS Undulator," LBL-29921 (May 1991).
7. R. Savoy, et al., Calculation of Magnetic Error Fields in Hybrid Insertion Devices, LBL-27811.
8. E. Hoyer, "Magnetized Neodymium-Iron-Boron Blocks," LBL Specification 734D (April 1989).
9. E. Hoyer, "Backing Beam Design Calculations," LBL Engineering Note M6834 (May 1989).
10. E. Hoyer, "Flexible Yoke Design," LBL Engineering Note M7039B (July 1990).
11. J. Chin, "Magnetic Load Compensating Springs," LBL Engineering Note M6829 (April 1989).
12. J. Chin, "Drive System Backlash," LBL Engineering Note M6882 (August 1989).
13. E. Hoyer, "Vacuum Chamber Design," LBL Engineering Note M6806 (February 1989).
14. E. Hoyer, "CDR Vacuum Chamber Pressure Distribution," LBL Engineering Note M6844 (May 1989).

Table I.
ALS undulator specifications based on spectral requirements.

Parameters	Value
Useable harmonics	1st, 3rd, and 5th
Brightness requirement	5th harmonic reduction < 30%
Spectral broadening req.	ID broadening \leq ALS emittance effects
Minimum increment of photon energy	1/10 of 5th bandwidth
Minimum time to go from min. to max gap (slew)	5 minutes
Maximum photon energy scan rate	1 bandwidth/second

Table II.

ALS insertion device specifications based on storage ring requirements.

Parameter	Limit
$\int B_y dl$	100 G cm*
$\iint B_y ds dl$	100 G cm ²
$\int B_x dl$	500 G cm
Integrated quadrupole	50 G*
Integrated skew quadrupole	50 G*
Integrated sextupole	50 G/cm*
Integrated octupole	1 G/cm ² *
Required vacuum	10 ⁻⁹ Torr

* Or the sum of these within a 1 cm x 6 cm aperture must not exceed 300 G cm.

Table III.
U5.0 Undulator engineering design parameters.

Parameter	Value
Maximum peak field (@ 1.4 cm magnetic gap)	0.89 T
Effective peak field (@ 1.4 cm magnetic gap)	0.837 T
Period length	5 cm
Number of periods	89
Number of full field poles	179
Nominal entrance sequence	0,-1/2,+1,-1
Overall length	455.8 cm
Pole width	8 cm
Pole height	6 cm
Pole thickness	0.8 cm
Number of blocks per half-period	6
End correction range (B_y)	1,500 G cm
End correction range (B_x)	None
Steering coils (short)	~ 25 cm
Dipole trim coils (long)	4.5 m
Steering and trim field strength	± 5 G
Systematic gap variation	58 μm

Table IV.
U5.0 Magnetic Structure tolerances.

Error Type	Total Tolerance	Error (%)
Spacing CSEM to pole	102 μm	0.08
Pole thickness	50 μm	0.03
Vertical pole motion (gap)	22 μm	0.05
Pole width	100 μm	0.03
Surface easy axis orientation	± 2.3 degrees	<u>0.16</u>
	Total:	<u>0.19</u>

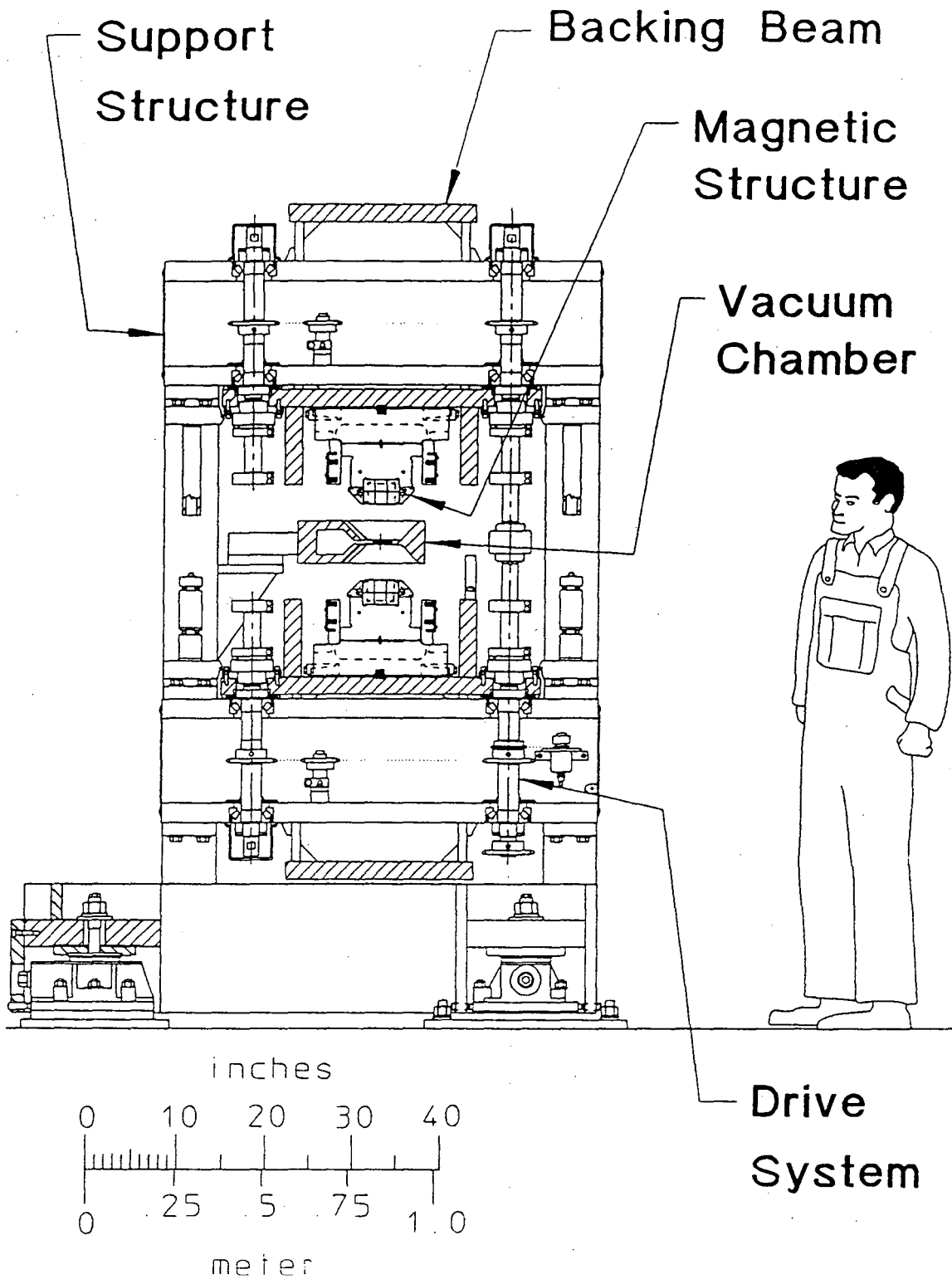
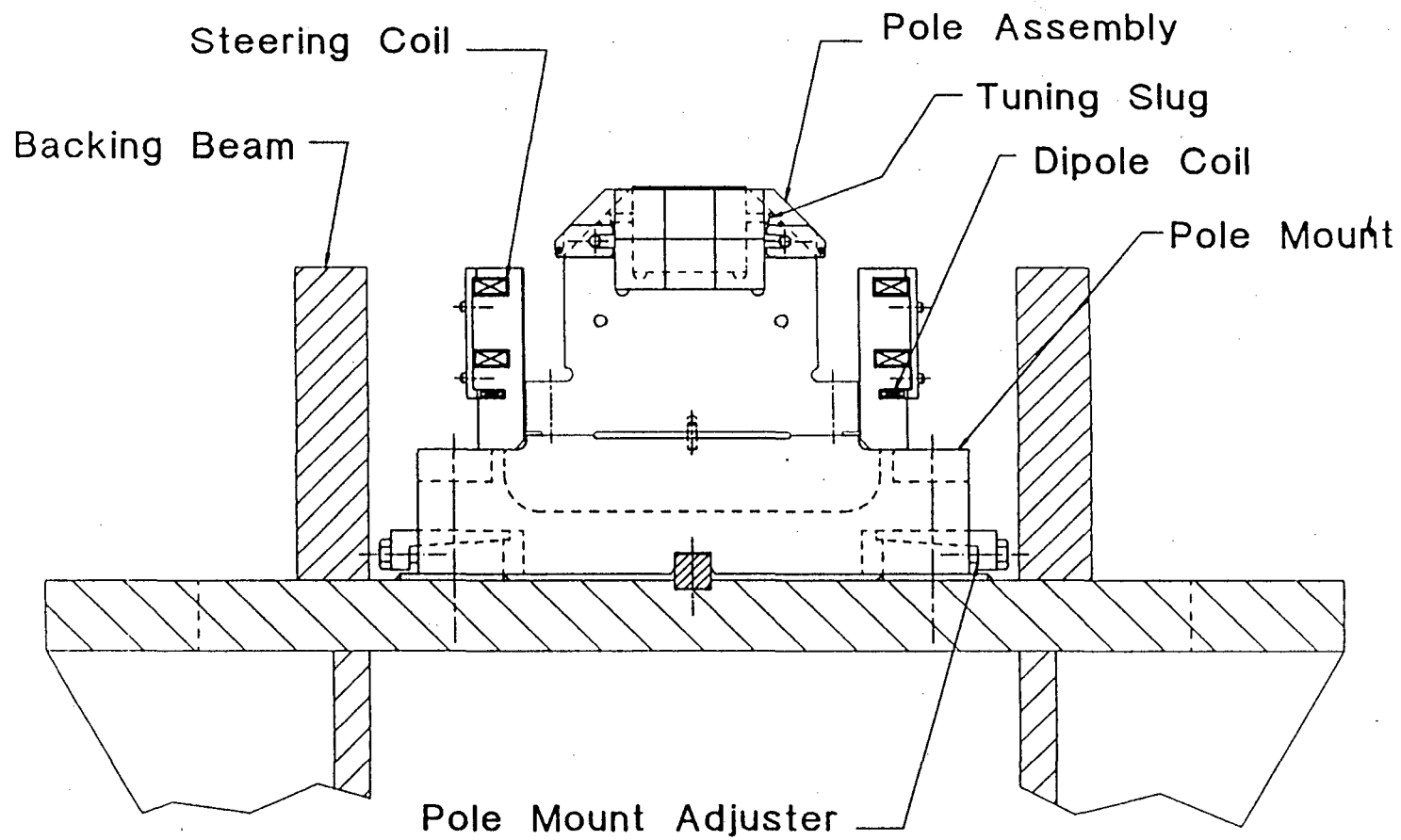

Fig. 1. U5.0 Undulator Design.

XBL 916-1337



XBL 916-1338

Fig. 2. U5.0 magnetic structure assembly section.

Standard Half Period
Pole Assembly

Pole Mount

Rotors

End Keeper
Assembly

End Pole Mount

Backing Beam

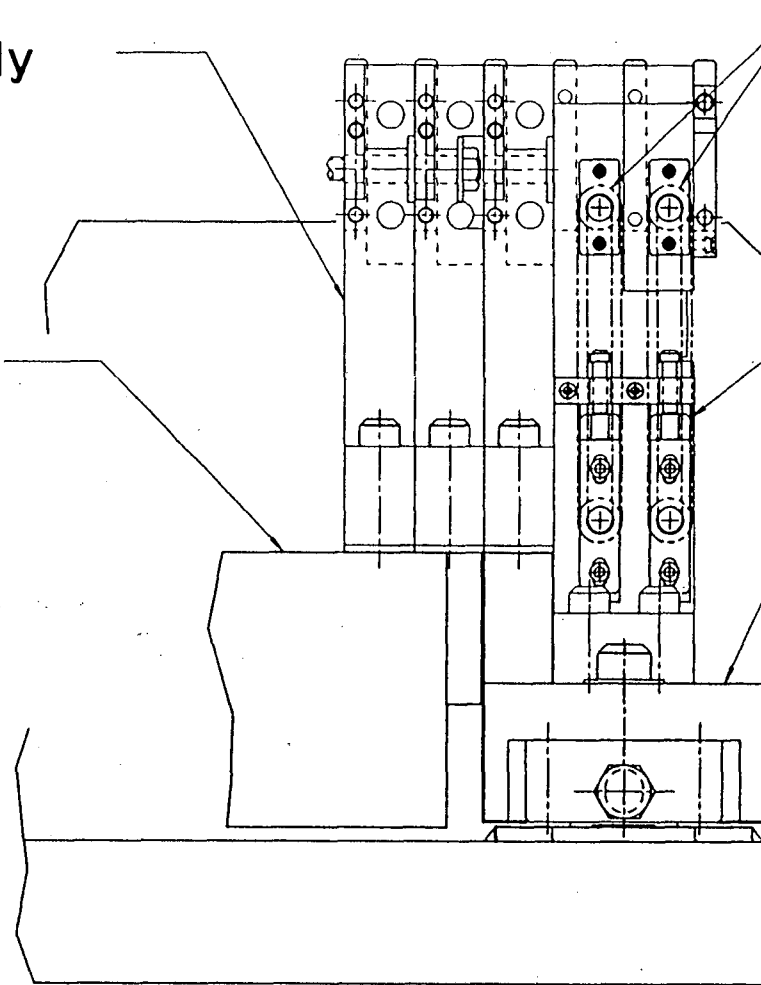

XBL 916-1339

Fig. 3. End pole assembly.

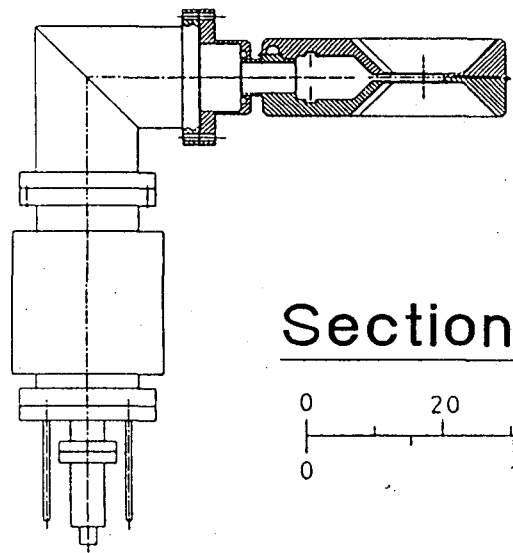
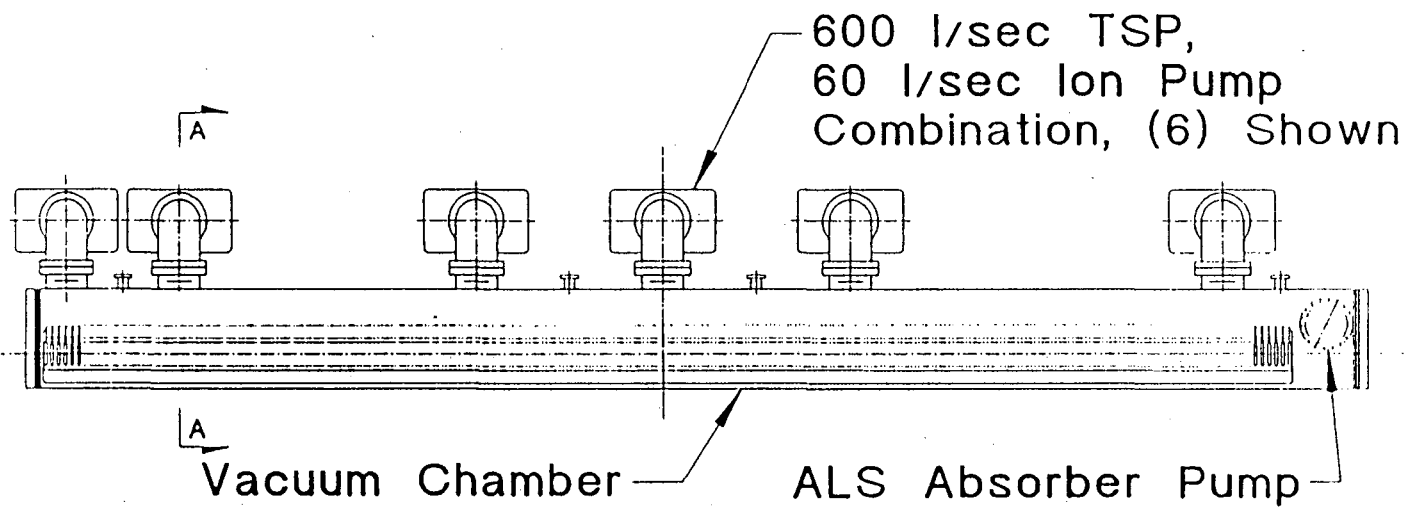

Section AA

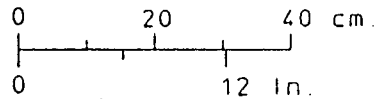

Vacuum Chamber
Plan View

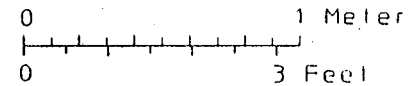

XBL 916-1340

Fig. 4. Undulator vacuum system layout.

LAWRENCE BERKELEY LABORATORY
UNIVERSITY OF CALIFORNIA
INFORMATION RESOURCES DEPARTMENT
BERKELEY, CALIFORNIA 94720