

# Lawrence Berkeley National Laboratory

## Recent Work

### Title

SUMMARY OF THE STATUS OF NEGATIVE-ION BASED NEUTRAL BEAMS

### Permalink

<https://escholarship.org/uc/item/8vg568c4>

### Author

Cooper, W.S.

### Publication Date

1983

c.2



# Lawrence Berkeley Laboratory

UNIVERSITY OF CALIFORNIA

## Accelerator & Fusion Research Division

RECEIVED  
LAWRENCE  
BERKELEY LABORATORY

OCT 19 1983

LIBRARY AND  
DOCUMENTS SECTION

Presented at the 5th Topical Meeting on the  
Technology of Fusion Energy, Knoxville, TN,  
April 26-28, 1983

SUMMARY OF THE STATUS OF NEGATIVE-ION  
BASED NEUTRAL BEAMS

W.S. Cooper

January 1983

### TWO-WEEK LOAN COPY

*This is a Library Circulating Copy  
which may be borrowed for two weeks.  
For a personal retention copy, call  
Tech. Info. Division, Ext. 6782.*

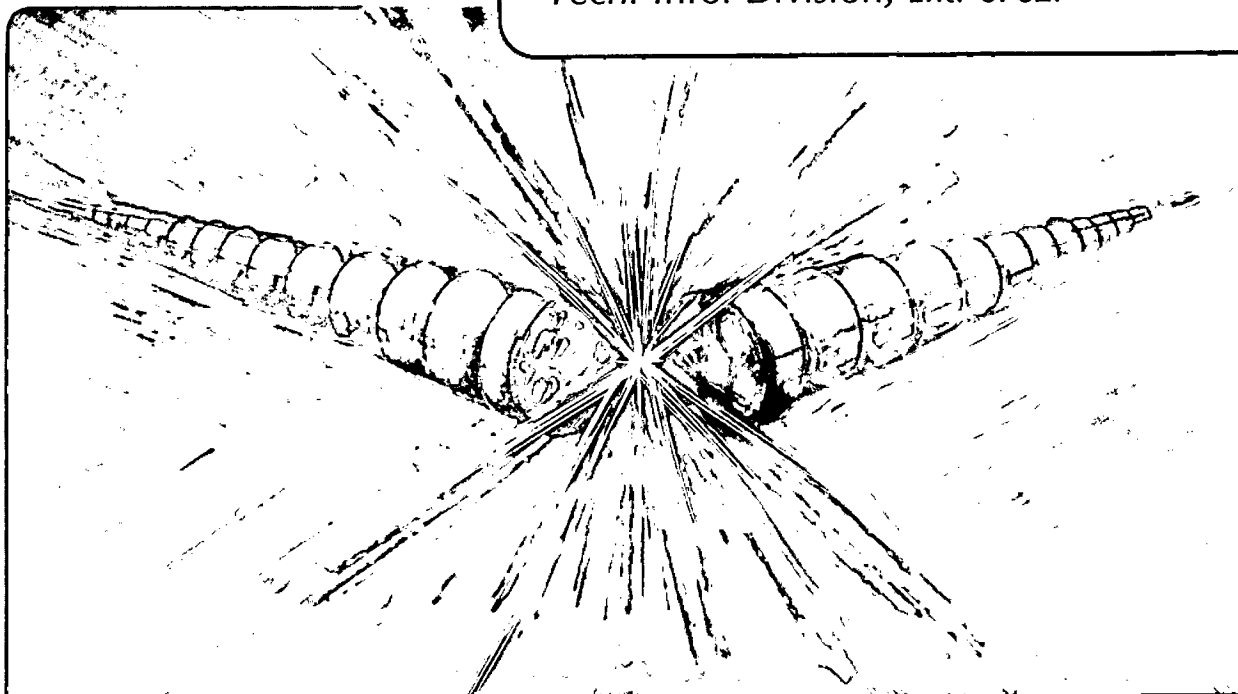

LBL-15616  
c.2

## **DISCLAIMER**

This document was prepared as an account of work sponsored by the United States Government. While this document is believed to contain correct information, neither the United States Government nor any agency thereof, nor the Regents of the University of California, nor any of their employees, makes any warranty, express or implied, or assumes any legal responsibility for the accuracy, completeness, or usefulness of any information, apparatus, product, or process disclosed, or represents that its use would not infringe privately owned rights. Reference herein to any specific commercial product, process, or service by its trade name, trademark, manufacturer, or otherwise, does not necessarily constitute or imply its endorsement, recommendation, or favoring by the United States Government or any agency thereof, or the Regents of the University of California. The views and opinions of authors expressed herein do not necessarily state or reflect those of the United States Government or any agency thereof or the Regents of the University of California.

SUMMARY OF THE STATUS OF  
NEGATIVE-ION BASED NEUTRAL BEAMS

WILLIAM S. COOPER, Lawrence Berkeley Laboratory  
University of California  
Berkeley, CA 94720 USA  
(415) 486-5011

ABSTRACT

Negative-ion-based neutral beam systems can perform multiple functions for fusion reactors, such as heating, current drive in tokamak reactors, and establishing and maintaining potential barriers in tandem mirror reactors. Practical systems operating continuously at the 200 keV, 1 MW level can be built using present-day technology. Ion sources have been demonstrated that produce  $D^-$  beams with <5% electron content, and that operate at linear current densities that are within a factor of 2 of what conservatively designed accelerator/transport structures can handle. Concepts are in hand for transporting the negative ion beam through a neutron maze before neutralization, thus permitting a radiation-hardened beamline. With an advanced laser photoneutralizer, overall system power efficiencies of 70% should be possible. A national program is being planned to achieve the goal of application of 475 keV systems on a mirror ETR in 1994.

I. THE NEED FOR NEGATIVE-ION BASED  
NEUTRAL BEAMS

A. Applications of neutral beams on  
fusion reactors

The injection of powerful beams of neutral hydrogen or deuterium atoms provided the first means of heating magnetically confined plasmas to fusion temperatures and sustaining them. The highest ion energies reported in confinement experiments to date, a mean ion energy of 13 keV in the 2XII-B mirror experiment at the Lawrence Livermore National Laboratory (LLNL) and an ion temperature of 7 keV in the PLT tokamak experiment at the Princeton Plasma Physics Laboratory (PPPL), were achieved with neutral beam heating.

Heating is not the only possible application of neutral beams to reactors, however. In the case of mirror machines, successful operation of a tandem mirror depends on the use of neutral beams to create

and sustain a local potential hill in the "plug" cell; it is this potential barrier that confines ions that would otherwise escape from the machine in the axial direction. This concept has been demonstrated in the TMX experiment at LLNL.

Neutral beams may also be used to advantage in the case of tokamaks in another context besides heating. It is highly desirable to be able to operate a tokamak reactor either steady-state or in a very long pulse mode to avoid mechanical fatigue induced by cyclic stresses. One possible means of achieving this goal is to drive the circulating current by the tangential injection of neutral beams. These beams would also heat the plasma, so the same system could serve two purposes. Two schemes have been proposed: in the first,<sup>1</sup> the beams are operated continuously and drive the current in steady state; in the second,<sup>2</sup> the "internal transformer" mode, beams are used intermittently to drive a current which is then allowed to "coast" for a fraction of the L/R decay time before the cycle is repeated. The internal transformer mode is expected to be more efficient than steady-state current drive; current drive efficiencies in this mode should be of the order of 1 A/W, as opposed to approximately 0.1 A/W for steady-state current drive.

Neutral beams have been produced to date up to energies of 120 keV. The energies required to achieve the goals just discussed are substantially higher; with the exception of steady-state current drive for tokamaks, which may never be used because of the low efficiency, all applications discussed above can be satisfied by neutral beam systems operating at 400-500 keV and capable of injecting 10-50 MW of beam power. These requirements serve as goals for the U.S. negative-ion-based neutral beam program.

B. Positive versus negative ions

All neutral beam systems operated on

fusion experiments to date have been produced by accelerating positive ions and then allowing the ions to pass through a gas target where a fraction of the ions is converted to neutral atoms by electron capture from the background gas. The efficiency of conversion of positive ions to neutrals by this process depends (for a sufficiently thick gas target) only on the energy dependence of the electron capture and loss cross sections; unfortunately, the energy dependence of these cross sections is such that the conversion efficiency decreases with increasing energy. The conversion efficiencies for both positive and negative ions are shown in Figure 1, which shows us that the efficiency of production of neutral beams from positive ions is unacceptably low for the applications that we have in mind.

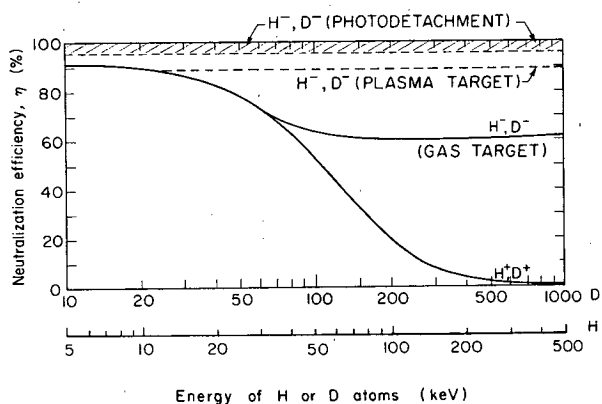

Fig. 1 Energy dependence of the maximum efficiency for conversion of positive and negative ions to neutrals for various neutralizers

The solution is to accelerate negative, rather than positive ions. The binding energy of the extra electron is only 0.75 eV, which makes it easy to strip the electron off by a variety of means. Three are shown: gas, plasma, and photon targets. In all three cases, the conversion efficiency is acceptably high for any application so far proposed in the Magnetic Fusion Energy (MFE) program. It is clear, then, that if we are to develop multi-hundred keV beams of atoms for fusion applications, we must start with negative ions.

## II. GENERAL SYSTEM CONSIDERATIONS

### A. Neutronics

Neutronics considerations dictate the

design of negative-ion-based neutral beam systems to be used on fusion reactors. The beams of neutral atoms must follow straight line trajectories through a penetration in the reactor shielding on their way to the plasma. Neutrons, unfortunately, exit via the same shielding penetration. If this were permitted to happen, the reactor shielding must be extended around the entire neutral beamline, which becomes radioactive by neutron activation, and must be remotely maintained. This is a severe disadvantage of this type of system.

Our goal is to find beam transport systems capable of transporting the negative ion beam through a maze in the neutron shielding before it is converted to neutrals; the ion beam is then neutralized after passage through the maze. Such a maze must attenuate the neutron flux by a factor of  $10^4$ - $10^8$ , depending on the application, to reduce activation of the source and accelerator to a low level.

We must bear these constraints in mind as we discuss source, accelerator, and neutralizer concepts.

### B. Sources

Negative-ion-based systems have many of the same requirements as positive-ion-based systems. We need a source of negative ions that produces copious quantities of negative ions at a reasonable energy cost, and with a reasonable transverse energy spread. We can deduce what a reasonable transverse energy is in this case by comparison with familiar positive-ion systems, which have an apparent ion temperature in the source of about 1 eV, and produce adequately good beams at 120 keV. Other things being equal, if we increase the beam energy by a factor of 4 to the energy required for negative-ion based beams, we can increase the transverse energy by the same factor, to about 4 eV, without suffering in beam quality. A difficult problem in negative ion work is that the ions have a charge of the same sign as electrons; accelerators employing only electric, and not magnetic, fields will accelerate any electrons from the source along with the negative ions. Some means must therefore be found to reduce the electron content in the beam to a tolerable level (a few percent). The source should operate with high gas efficiency to reduce the loss of accelerated negative ions by stripping on the background gas in the beamline, and should also put out only small concentrations of impurity negative ions.

Negative-ion-based systems for these proposed applications tend to be low current, high voltage systems, compared with positive ion systems that we are accustomed to. This is fortunate, as we do not know how to produce steady state negative ion sources that are capable of generating the current densities obtainable with positive ion sources.

#### C. Transport and acceleration systems

The primary function of this system, as the heading suggests, is to accelerate the beam of negative ions and to transport the beam through a maze in the neutron shielding. This must be accomplished with little beam loss and with low induced aberrations. It is highly desirable to be able to bend the beam for transport through the neutron shield with a radius that is commensurate with the thickness of the shield, that is, with a radius of less than 1 m. Otherwise, one cannot design a compact maze.

Electrostatic strong-focusing systems are the primary candidates for these applications. Electrostatic systems offer advantages over rf systems, in that they do not suffer from effective beam loss due to the rf duty factor (the fraction of the cycle during which beam can be accelerated), because the power supplies are more efficient, since one does not have to convert the dc to rf, and because rf cavity losses are avoided. A critical question, however, and one that can only be answered experimentally, is whether or not the required energy levels of 400 keV and up can be reached with dc technology.

Transport structures have to be thin in one dimension for easy gas removal; they tend to be long in the other direction to increase the total beam current. These considerations, plus the necessity to match the geometries of sources and efficient neutralizers, lead to systems capable of transporting a sheet beam or an array of beamlets in a sheet-like configuration. An appropriate measure of performance is therefore the linear current-carrying capability in A/m.

#### D. Neutralizers

The function of the neutralizer is to convert the negative ions into neutral atoms by stripping one electron. As was shown in Figure 1, this can be accomplished in a gas cell, a plasma cell, or a photon target which uses photodetachment. The physics is well understood in all three cases.

### III. STATUS OF COMPONENT DEVELOPMENT

#### A. Sources

Three types of negative ion sources are under development in fusion laboratories throughout the world. In these sources, negative ions are produced on a surface imbedded in a plasma (surface-production sources), in the volume of a plasma (volume-production sources), or by double electron capture in alkali or alkaline earth metal vapors (charge-conversion sources).

In surface-conversion sources, the negative ions are produced on a cesiated electrode (the "converter") imbedded in the source plasma. A diagram of a typical surface-conversion source, under development<sup>3</sup> at Brookhaven National Laboratory (BNL), is shown in Figure 2. In this source, plasma is produced in a magnetic field by a hollow cathode discharge. Negative ions are produced on a negatively biased cesiated molybdenum converter, are accelerated through the potential difference between the converter and the plasma, and exit through slots in the part labeled "cover", which also serves as the first electrode of a multiple-aperture electrostatic accelerator. Electrons accelerated along with the negative ions have a shorter radius of curvature in the magnetic field and are swept out. The best substrate for the converter found to date is molybdenum; maximum negative ion yield occurs for a cesium cover-

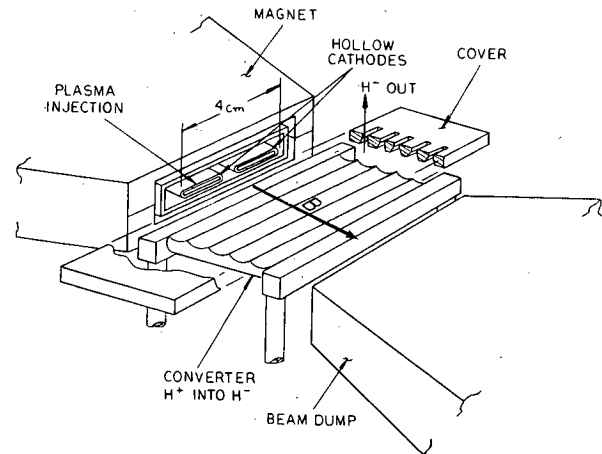

Fig. 2 Surface-conversion source under development at Brookhaven National Laboratory

age of about 0.5 monolayers, which coincides with the minimum work function of the surface ( $\sim 1.5$  eV). Maintaining the proper cesium coverage during steady-state operation is a major problem with this type of source.

TABLE I. Status of surface-conversion source development in the U.S.

Parameter	Source		
	Multicusp (LBL)	SITEX (ORNL)	Hollow Cathode (BNL)
Converter Area (cm <sup>2</sup> )	200	25	25
H <sup>-</sup> Current In Steady State Operation (A)	1.3	0.55	0.2
H <sup>-</sup> current Density At Converter (A/cm <sup>2</sup> )	0.0065	0.05	0.008
Linear H <sup>-</sup> Current Density (A/m)	5.2	5.7	4
Pressure (mTorr)	1	4	1
G <sup>-</sup> Efficiency (%)	12	3	>20 Estimated)

Results achieved to date for three surface-conversion sources under development<sup>3,4,5,6</sup> in the U.S. are shown in Table I. These sources typically operate at pressures of 1-5 mTorr, with plasma densities of  $10^{12}$ - $10^{13}$  cm<sup>-3</sup>. The origin of the negative ions is not understood and is presently the subject of lively debate. They are born on the converter surface, but the relative roles of back-scattering and desorption are not clear. There is an isotope effect; D<sup>-</sup> yields are approximately 70% of the H<sup>-</sup> yield. It is believed that all three sources can be extended in one direction to increase the total current per source; the equivalent D<sup>-</sup> current per unit length achieved to date during steady-state operation approaches 4 A/m of source length. Gas efficiencies of 10% or higher have been measured, and impurity contents of 1% or less have been observed. Magnetic fields, weak enough to permit passage of the heavy negative ions, but strong enough to impede plasma electrons, in conjunction with biased electrodes near the exit, have been successfully used to reduce the electron content in the beam to less than 5%. The transverse energy spread of the ions exiting the source is of the order of 5 eV, which is adequately small. These parameters have been achieved simultaneously in a single surface-conversion source, so it appears that we are close to achieving a suitable source design for steady-state operation on practical negative-ion-based neutral beam systems. Surface-conversion sources for fusion use are also under development at the Institute of

Nuclear Physics, Novosibirsk, the Kernforschungszentrum, Karlsruhe, and the Institute for Plasma Physics, Nagoya.

Volume-production sources are being studied at the Culham Laboratory, Ecole Polytechnique, Lawrence Berkeley Laboratory (LBL), and the Japan Atomic Energy Research Institute (JAERI). This development is not yet as advanced as that of surface-production sources, but shows promise. An astonishingly high fraction of the negative particles in otherwise "normal" (and cesium-free) plasmas has been found to consist of negative hydrogen ions - up to 35% at electron densities of  $10^{10}$  cm<sup>-3</sup>,<sup>7</sup> and even a few percent at densities of over  $10^{11}$  cm<sup>-3</sup>. There is not full agreement on the origin of these negative ions; the most promising theory holds that they are produced during dissociative attachment collisions of electrons with vibrationally excited hydrogen molecules. These volume-production sources offer the advantage of operation without cesium but electron control is more difficult than with the surface-production sources; extracted beams to date have contained 50% or more electrons.

When a beam of positive ions passes through an alkali or alkaline earth metal vapor target, there is a substantial probability of conversion to negative ions by double electron capture. Figure 3 shows the conversion probability as a function of energy for deuterium ions incident on various metal vapor targets. This is the basis for charge-conversion sources, which are being developed at the Centre d'Etudes Nucleaires, Grenoble, and the Kurchatov Institute. A supersonic metal vapor jet can provide a suitable target; in fact, the highest beam currents produced to date in any source with long pulse capability, 2.2 A of D<sup>-</sup>, have been produced this way.<sup>8</sup> In spite of this, and in spite of the fact that the vapor jet also serves as a gas barrier to inhibit the flow of source gas into the rest of the beamline, this approach is not now being pursued in the U.S. The chief reasons are the likelihood of contamination of the beamline and reactor with alkali metal, the difficulty of matching the beam to a suitable accelerator and neutralizer, and the difficulty of controlling electrons in the beam.

#### B. Transporters and accelerators

All transport and accelerator systems now under consideration use electric strong

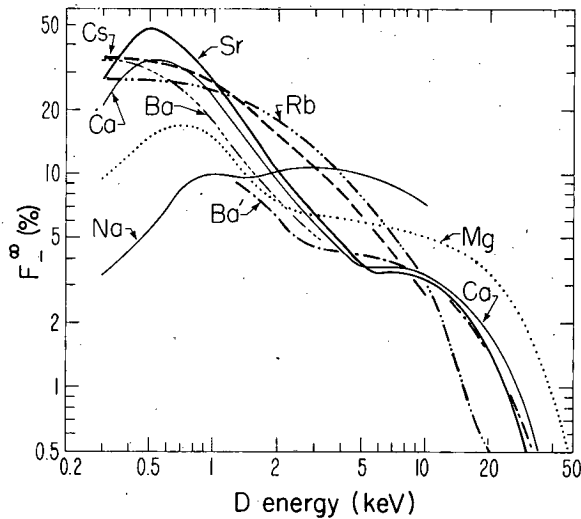

XBL 809-2011B

Fig. 3 Efficiency of production of  $D^-$  ions as a function of energy in various alkali and alkaline earth metal vapors

focusing. These systems offer a high current carrying capability (compared with weak focusing systems), a tolerance of variations in beam parameters (because the beam space charge is only a small perturbation on the vacuum fields), and an anticipated resistance to total column breakdown (because of the spatially alternating transverse electric fields). The last point is crucial; for reasons already discussed, it is important to push dc technology at least to the 500 kV point.

The two dc electrostatic accelerators that have received the most consideration are the Transverse Field Focusing (TFF)<sup>9</sup> and the Electrostatic Quadrupole (ESQ)<sup>10</sup> designs. In a multiple aperture version of the ESQ, shown configured as a transporter in Figure 4, the sets of electrodes can be mounted on supporting plates and biased in such a way that either transport or acceleration can be accomplished. This type of structure has been analyzed for beam quality<sup>10</sup> and for pumping capability<sup>11</sup> (if gas is introduced along with the beam, as is the case if the accelerator is adjacent to the ion source, it is important to be able to pump the gas out the side of the structure to minimize stripping

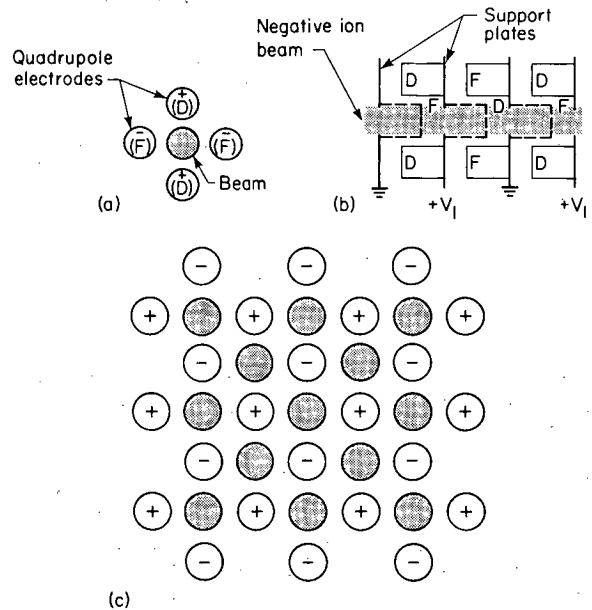

XBL-827-7259

Fig. 4 Schematic of multiple-aperture ESQ beam transporter; "F" signifies focusing; "D" signifies defocusing

losses). The ESQ appears to be satisfactory in both respects.

In the TFF system, periodic deflection focusing<sup>12</sup> is used. A sheet beam can be transported through an array of suitably biased and curved electrodes; as the beam progresses through the system, the sense of the transverse electric field and the curvature of the electrodes alternate, so that the beam follows a sinuous path between the pairs of electrodes. End effects can be controlled by suitably shaping the electrodes near the edges of the beam. If successive pairs of electrodes are at different mean potentials with respect to each other, the beam can be accelerated as well as transported. Calculated ion trajectories, with space charge included, through a TFF accelerator that accelerates an 80 keV beam to 400 keV, are shown in Figure 5. The linear current density is 8 A/m of  $H^-$ , or 5.6 A/m of  $D^-$ , and the total overall length of the accelerator is 92 cm. The maximum electric field, 40 kV/cm occurs in the gaps between pairs of electrodes. The maximum transverse





Fig. 5 Calculated ion trajectories through a TFF accelerator. Arrows show the direction of the electric force.

field is 23 kV/cm. Pumping capability and beam quality also seem to be satisfactory for TFF transporter and accelerator systems.

The TFF system offers a number of advantages over the ESQ system. It offers a better geometrical match to certain source concepts, especially the LBL surface-conversion source, and to advanced neutralizers. A particular advantage is that the bending radius for beam transport is around 0.5 m which makes the design of compact neutron mazes possible.

If it proves impractical to reach the desired energies of 500 to (possibly ultimately) 2000 keV with electrostatic systems, we will have to use rf accelerators. Two candidates have been considered here, the Radio Frequency Quadrupole (RFQ)<sup>13,14</sup> and an rf version of the ESQ, the Multiple Electrostatic Quadrupole Linear Accelerator (MEQALAC).<sup>15</sup>

The RFQ uses a single set of quadrupole vanes in a resonant cavity to provide an oscillating electric quadrupole transport system. By carefully machining scallops into the inner surfaces of the vanes, electric field components in the axial direction can be produced and used to efficiently bunch the beam and accelerate it. Several of these accelerators have been built, or are under construction, for application on high energy accelerators. The problems are the relatively high power losses in the cavity, the inefficiency introduced by the duty factor for acceleration, the difficulty of making a multiple-aperture version, and the poor geometric matching to advanced neutralizers.

The MEQALAC has also been successfully tested experimentally, but not yet with hydrogen or deuterium. The MEQALAC is a promising rf candidate, but suffers the common disadvantage of rf accelerators, the low power efficiency.

The anticipated performance of these four systems is compared in Table II. Because of its apparent advantages, the major effort now is going into the development of the TFF accelerator. We are building at LBL a new surface-conversion source and an 80 keV preaccelerator which will begin operation during the summer of 1983 and which will serve as an injector for the demonstration of transport of an 80 keV H<sup>-</sup> beam in the summer of 1984 and of TFF acceleration of the beam to 160-180 keV by January, 1985.

TABLE II. Anticipated characteristic of possible negative-ion accelerators.

Parameter	Accelerator Type			
	dc		rf	
	TFF	ESQ	MEQALAC	RFQ
Typical D <sup>-</sup> Current	6 A/m	6 A/m	6 A/m	2 A
Accelerator Power Efficiency	95%	95%	<35%	35%
Pumping Capability	Good	Good	Good	Poor
Match to Neutralizer	Very Good	Good	Fair	Poor
Bend Radius for Transport	0.5 m	15 m	≥2 m	N.A.
Experimentally Tested?	No	No	Yes	Yes

It appears that we are likely to be limited ultimately by the current-carrying capability of the accelerators, rather than by the current production capability of the sources. The TFF design in Table II has electric fields that nowhere exceed 40 kV/cm (electrode-to-electrode), a value that we believe to be conservative. At this field strength, the TFF structure can transport or accelerate 6 A/m of D<sup>-</sup> ions to around 500 keV. As we saw in Table I, present-day sources have operated at 5.2 A/m of H<sup>-</sup>, which is equivalent to 3.6 A/m of D<sup>-</sup>, and further improvement can be expected. This is a very important point: negative ion sources are already operating in steady state at linear current densities that are within a factor of 2 of what conservatively designed accelerators can handle.

Total beam powers for hypothetical beam-lines are approaching useful values, also: a source and accelerator producing 3.6 A/m at

500 keV would deliver 1 to 1.7 MW/m of energetic  $D^0$  neutrals, depending on the neutralizer used, with good prospects for doubling these values within the next few years. When sources can produce higher linear current densities, the beams can be accelerated at the expense of a less conservative accelerator design with higher electric fields; alternatively, some of the current can be discarded constructively at low energy to improve the gas efficiency, the beam divergence, or both.

### C. Neutralizers

The most likely choices for a neutralizer to convert the negative ions to neutrals are a gas target, a plasma target, or a photon target. All three have a solid experimental basis<sup>16,17,18</sup> and there appear to be no unresolved questions in the physics of converting the negative ions to neutrals. The characteristics of the three candidates are summarized in Table III.

TABLE III. Characteristics of possible negative-ion neutralizers

Parameter	Neutralizer Type		
	Gas Target ( $D_2$ )	Plasma Target	Photon Target
Potential Conversion Efficiency ( $D^-$ , 500 keV)	~60%	~80%	≥95%
Gas Load	Large	Small	None
Power Remaining In $D^-$ Ions	~20%	~10%	<5%
Power Remaining In $D^+$ Ions	~20%	~10%	None
Can Discriminate Against Impurities?	No	No	Yes
Power Cost	Small	Under Investigation	Under Investigation
Available	~Now	~1986	~1988

The gas target is straightforward and holds no surprises. Its chief disadvantage is that it has the lowest conversion efficiency of the three, 60%, and requires large cryo-panel areas to handle the gas load, so that stripping losses in other parts of the beamline remain small. Another disadvantage is that the 40% of the beam that remains after neutralization consists of roughly equal portions of negative ions (which have not been

converted to neutrals) and positive ions (which have had both electrons removed), necessitating two charged particle dumps in the beamline, each required to handle a substantial fraction of the beam power.

One can gain in conversion efficiency by going to a plasma target.<sup>19</sup> To make a substantial gain in conversion efficiency over a gas target, for the case of  $D^-$  in a deuterium plasma, the plasma must be of the order of 40% ionized or more.<sup>20</sup> The power required to sustain such a plasma is still under investigation; a plasma target under development at BNL is expected to require about 0.5 kW/cm<sup>2</sup> of cross sectional area.<sup>21</sup> Since it is conceivably possible to produce the plasma in one location and then transport it to the target area with weak magnetic fields, and to apply differential pumping in between, harmful gas input into the beamline is likely to be quite a bit smaller than in the case of the gas target. Both these types of targets will also neutralize at least a fraction of the negative impurity ions in the beam, which will permit the neutralized impurities to enter the plasma.

Utilization of neutralization by photodetachment in a photon target seems to represent the best ultimate choice for an efficient neutralizer. In this application, the negative ion beam is directed through the resonant cavity of a laser. With photonneutralizer lengths of 2-3 m, conversion efficiencies of over 95% seem possible to achieve.<sup>22</sup> The currently favored candidate laser is the oxygen-iodine chemical laser as suggested by McGeoch;<sup>23</sup> these lasers, under development with Department of Defense (DOD) funding, operate at 1.315  $\mu$ . Such a neutralizer would produce no additional gas, would leave little additional charged beam to dispose of, and would have the additional advantage that common negative impurity ions ( $OH^-$ ,  $C^-$ , and  $O^-$ ) have binding energies too high to be stripped by 1.315  $\mu$  photons, thus offering some degree of discrimination against impurities in the beam.

The reason that this approach is not planned to be used initially, of course, is that suitably powerful lasers are not yet available. Oxygen-iodine lasers of a few hundred watts have operated continuously, lasers of a few kW have operated for minutes, and lasers of  $\geq 10$  kW are under development. For reactor applications, we need a laser dissipating the order of 100 kW continuously in the cavity. Virtually all this power is

consumed heating up the windows and mirrors of the laser; only a negligible amount of power (0.75 volts x beam current in amperes, at most 10's of watts) is used to convert the negative ions to neutrals.

In a continuously operating system, the chemicals required would probably be recycled locally in a chemical plant. Total input power to the laser system might be as large as 1-2 MW, but this number is very uncertain since it depends critically on mirror technology and on the efficiency of the chemical plant, which is also not known. Since a single laser cavity will strip as much negative ion beam as can be injected into it, the power requirement for the laser plant is a relative quantity: a 2 MW laser plant is not reasonable for a 1 MW neutral beam system, but becomes highly efficient for a 25 MW neutral beam system.

#### IV. STATUS OF SYSTEM STUDIES

##### A. 200 keV studies

As a result of a DOE-incited competitive program review in September, 1981, three laboratories, BNL, LBL, and Oak Ridge National Laboratory (ORNL), produced conceptual designs<sup>24,25,6</sup> for a 200 keV, 1 MW negative-ion based beamline capable of operating continuously. As an example, we show in Figure 6 a schematic of the ORNL design.<sup>6</sup>

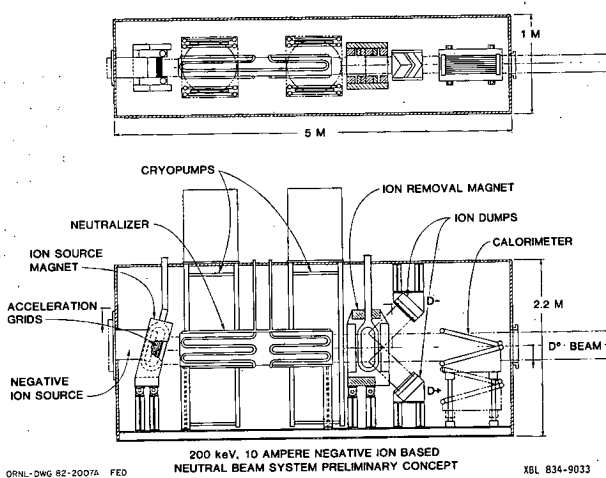

Fig. 6 200 keV, 1 MW negative-ion beamline using existing technology

This beamline uses conventional technology and involves only reasonable extrapolations from the current state-of-the-art. The design uses a single 10-A SITEX negative ion source; the neutralizer is a separated gas target with flow out both ends of the channel. Cryopumps provide a pumping speed of approximately  $10^6$  l/sec which should be adequate to maintain the system pressure at around  $10^{-5}$  Torr, resulting in tolerable stripping losses of about 15%. An electromagnet is used to separate the residual  $D^+$  and  $D^-$  beams which are deflected to separate dumps. Magnetic fields (part of the SITEX source) are also used to control the electron content in the beam and to eliminate negative impurity ions. The beamline is approximately the size of a positive-ion PDX beamline, and would operate at comparable efficiency, but would produce a mono-energetic beam at 200 keV with half the power of the 50 keV PDX beam.

As these design studies indicate, it appears possible to produce a working beamline producing a 1 MW beam at 200 keV right now, using current technology and modest extrapolations from proven performance.

##### B. 400 keV studies

Several design studies have been performed for 400 keV and higher beam energies; two of the most recent are reported at this meeting.<sup>26,27</sup> As an example, we show in Figure 7 a conceptual design for an efficient, radiation-hardened 400 keV beamline capable of delivering 2 MW/m (of source length) of 400 keV, deuterium atoms to a

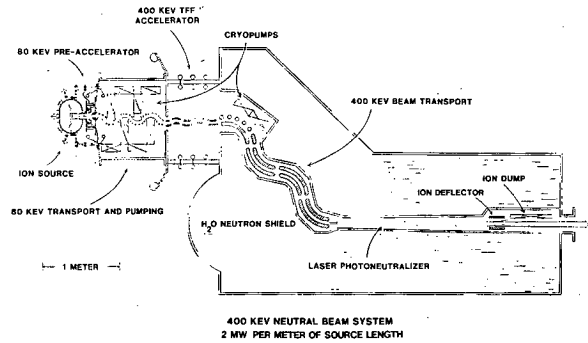

Fig. 7 400 keV, 2 MW/m (of source length) radiation hardened negative-ion beamline using advanced technology

plasma.<sup>27</sup> The design uses an LBL surface-conversion source, preacceleration of the D<sup>-</sup> beam to 80 keV, TFF transport at 80 keV through a differential pumping section, and a TFF accelerator to reach the final beam energy of 400 keV. A TFF transporter takes the 400 keV beam through a neutron maze to a laser photoneutralizer where approximately 95% of the ion beam is converted to neutrals. Monte Carlo gas calculations indicate a beam loss at 80 keV of about 15% and very small losses at 400 keV (the pressure in the transport region must be maintained at 10<sup>-6</sup> Torr or less). The overall power efficiency depends strongly on the details of the laser plant, and ranges from a probable low (assuming the laser system to be available!) of 50% to a probable high of 70%.

Preliminary neutronics estimates indicate an attenuation of the incoming neutron flux by a factor of 10<sup>6</sup> to 10<sup>8</sup>. It seems clear that the concept of blocking neutrons shown in Figure 7 will work, but additional and more careful neutronics calculations must be done before the complexity of the required maze can be determined. The goal is to permit "hands-on" maintenance of the source, accelerator, and cryopumps after shutdown of the reactor.

At this stage of the design, we recognize the necessity for tritium compatibility and remote handling features, but the design has not progressed to the point of including them explicitly. The same is true for magnetic shielding of the ion beam.

#### V. THE NATIONAL PROGRAM

There has been rapid progress in the last two years, both in hardware and in new concepts for negative-ion systems. System studies indicate that although a great deal of work remains to be done to develop the necessary hardware and to make it work, and ultimately to demonstrate system performance and reliability, the concepts that will lead to realistic systems are not lacking.

As part of a recent consolidation of the U.S. negative ion program, Department of Energy (DOE) has proposed LBL to be Lead Laboratory for the development of negative ion neutral beams. One task, now under way, is to develop, in conjunction with DOE, a national plan<sup>28</sup> for the development of negative-ion-based neutral beams. The plan is based on a need for 475 keV neutral beams on a mirror Experimental Test Reactor (ETR) in 1994,

which is the first perceived application of negative-ion-based systems on a fusion experiment. Development will be carried out by a combination of National Laboratories (BNL, LBL) and industry. An aggressive program is certainly required, but it appears feasible to reach the goal of operation of practical negative-ion-based systems by 1994.

#### ACKNOWLEDGEMENTS

I would like to thank all the people who have contributed to this paper, especially the following: Kristo Prelec, Oscar Anderson, and Joel Fink for the use of unpublished material they presented at a recent negative-ion workshop at PPPL on sources, transporters/accelerators, and neutralizers, respectively, Warren Stearns for helpful discussions on plasma and metal vapor neutralizers, John Hiskes for comments on the theoretical aspects of negative ion sources, and to the several members of the LBL Neutral Beam Group who have given me their comments and helpful advice. This work was supported by the Director, Office of Energy Research, Office of Fusion Energy, Development and Technology Division and Applied Plasma Physics Division of the U.S. Department of Energy under Contract No. DE-AC03-76SF00098.

#### REFERENCES

1. D.R. MIKKELSEN and C.E. SINGER, "Optimization of Steady-State Beam-Driven Tokamak Reactors," PPPL-1929, Princeton Plasma Physics Laboratory (1982); to be published in Nucl. Tech. Fusion.
2. C.E. SINGER and D.R. MIKKELSEN, "Continuous Tokamak Operation With An Internal Transformer," PPPL-1936, Princeton Plasma Physics Laboratory (1982); to be published in Jour. Fusion Energy.
3. J.G. ALESSI, ET AL, "BNL Negative Ion Based Neutral Beam Development" Proceedings of the Third Neutral Beam Heating Workshop, Gatlinburg, TN (Oct. 19-23, 1981), sponsored by the Fusion Energy Division, ORNL.
4. K.N. LEUNG and K.W. EHLERS, "Self-extraction Negative Ion Source," Rev. Sci. Inst., 53, 803 (1982).
5. W.K. DAGENHART, W.L. STIRLING, and J. KIM, "Negative Ion Beam Generation With the ORNL SITEX Source," ORNL/TM-7895, ORNL (1982).

6. W.K. DAGENHART, W.L. GARDNER, W.L. STIRLING, and J.H. WHEALTON, "Experimental Database and Design Concept for a 1-MW, 200 keV Neutral Beam Line Based on a SITEX Negative Ion Source," these Proceedings.
7. M.BACAL and G.W. HAMILTON, "H<sup>-</sup> and D<sup>-</sup> Production in Plasmas," Phys. Rev. Letts., 42, 1538 (1979).
8. E.B. HOOPER, JR., P. POULSEN, and P.A. PINCOSY, "High Current D<sup>-</sup> Production by Charge Exchange in Sodium," J. Appl. Phys., 52, 7207 (1981).
9. O.A. ANDERSON, D.A. GOLDBERG, W.S. COOPER, and L. SOROKA, "A Transverse-Field-Focusing (TFF) Accelerator for Intense Ribbon Beams," Bull. Am. Phys. Soc., 28, 103 (1983); to be published in Proceedings of the 1983 Particle Accelerator Conference, Santa Fe, NM (March 21-23, 1983).
10. D.A. GOLDBERG and O.A. ANDERSON, "Analytic Comparison of TFF and ESQ Systems," Bull. Am. Phys. Soc., 27, 1142 (1982).
11. C.F. BURRELL AND D.A. GOLDBERG, "Calculations of Gas Density in a Closely-Packed Multi-Channel Electrostatic Quadrupole (MESQ) Array," LBL-14631, LBL (1982); to be published in Jour. Vac. Sci. & Tech.
12. P.T. KIRSTEIN, G.S. KINO, and W.E. WATERS, Space-Charge Flow, McGraw-Hill Book Co., New York (1967), Chapter V.
13. R.H. STOKES, "Radio-Frequency Quadrupole Linear Accelerator for High-Current Applications," in Proceedings of the Workshop on the Formation and Acceleration of High Energy Neutral Beams for Magnetic Fusion, DOE/TIC-11371, U.S. DOE (1981).
14. K.R. CRANDALL, R.H. STOKES, and T.P. WANGLER, "RF Quadrupole Beam Dynamics Design Study," in Proc. of the 1979 Linear Accelerator Conf., BNL-51134, BNL (1979).
15. G.M. GAMMEL, A.W. MASCHKE, and R.M. MOBLEY, "New High-brightness Multiple Beam Linear Accelerator," Rev. Sci. Inst., 52, 971 (1981).
16. For a summary of relevant experimental cross sections and calculated yields in gas targets, see K.H. BERKNER, R.V. PYLE, and J.W. STEARNS, "Intense, Mixed-Energy Hydrogen Beams for CTR Injection," Nuc. Fusion, 15, 249 (1975).
17. G.I. DIMOV, A.A. IVANOV, and G.V. ROSLYAKOV, "Electron Loss of Fast H<sup>+</sup> and H<sup>0</sup> Atoms in a Plasma Target," Sov. Phys. Tech. Phys., 22, 1091 (1977).
18. H.C. BRYANT, P.A. LOVOI, and G.G. OHLSEN, "Production of Pulsed Particle Beams by Photodetachment of H<sup>-</sup>," Phys. Rev. Letts., 27, 1628 (1971).
19. D.R. SWEETMAN, ET AL, "Fast Neutral Injection for Plasma Heating and Reactor Start-up," Proceedings, Fourth Conference on Plasma Physics and Controlled Nuclear Fusion Research, Madison, WI (June 17-23, 1971); p. III393.
20. K.H. BERKNER, R.V. PYLE, S.E. SAVAS, and K.R. STALDER, "Plasma Neutralizers for H<sup>-</sup> or D<sup>-</sup> Beams," in Proc. of the 2nd International Symp. on the Production and Neutralization of Negative Hydrogen Ions and Beams, BNL, Upton, NY (1980).
21. K. PRELEC, Private Communication.
22. J.H. FINK, "Laser-Neutralized Negative Ions as a Source of Neutral Beams for Magnetic Fusion Reactors," UCRL-87301, LLNL (1982); submitted to Nucl. Tech. Fusion.
23. M.W. MCGEOCH, "Laser Neutralization of Negative Ion Beams for Fusion," in Proceedings of the Second International Symposium on the Production and Neutralization of Negative Hydrogen Ions and Beams.
24. K. PRELEC, ET AL, "A Neutral Beam System Based on BNL Negative Hydrogen Ion Sources," Proceedings of Third Joint Varenna-Grenoble International Symposium on Heating in Toroidal Plasmas, Grenoble (March 22-26, 1982); to be published.
25. D. GOLDBERG, O. ANDERSON, W. COOPER, and J. TANABE, "Conceptual Design of a 200 keV, 1 MW Negative-Ion-Based Neutral Beam Line," Jour. Fusion Energy, 3, 67 (1983).
26. S.A. FREIJE, D.J. GOEBEL, and L.J. PERKINS, "MARS Heating Systems," these Proceedings.
27. O.A. ANDERSON, ET AL, "Efficient, Radiation-Hardened, 400 and 800 keV Neutral Beam Injection Systems," these Proceedings.
28. "The National Negative-Ion-Based Neutral Beam Development Plan," W.S. COOPER and R.V. PYLE, editors (in preparation).

This report was done with support from the Department of Energy. Any conclusions or opinions expressed in this report represent solely those of the author(s) and not necessarily those of The Regents of the University of California, the Lawrence Berkeley Laboratory or the Department of Energy.

Reference to a company or product name does not imply approval or recommendation of the product by the University of California or the U.S. Department of Energy to the exclusion of others that may be suitable.

TECHNICAL INFORMATION DEPARTMENT  
LAWRENCE BERKELEY LABORATORY  
UNIVERSITY OF CALIFORNIA  
BERKELEY, CALIFORNIA 94720