

Lawrence Berkeley National Laboratory

Recent Work

Title

THE TRIAX PINCH DEVICE

Permalink

<https://escholarship.org/uc/item/8vd7061w>

Authors

Anderson, O.A.

Baker, W.R.

Ise, J.

et al.

Publication Date

1958

~~CONFIDENTIAL~~
DECLASSIFIED

UNIVERSITY OF
CALIFORNIA

Radiation
Laboratory

~~CONFIDENTIAL~~
This document contains restricted information under the Atomic Energy Act of 1954. The transmission or the disclosure of its contents in any manner to an unauthorized person is prohibited.

TWO-WEEK LOAN COPY

*This is a Library Circulating Copy
which may be borrowed for two weeks.
For a personal retention copy, call
Tech. Info. Division, Ext. 5545*

BERKELEY, CALIFORNIA

~~CONFIDENTIAL~~

UCRL-8153 C2

DISCLAIMER

This document was prepared as an account of work sponsored by the United States Government. While this document is believed to contain correct information, neither the United States Government nor any agency thereof, nor the Regents of the University of California, nor any of their employees, makes any warranty, express or implied, or assumes any legal responsibility for the accuracy, completeness, or usefulness of any information, apparatus, product, or process disclosed, or represents that its use would not infringe privately owned rights. Reference herein to any specific commercial product, process, or service by its trade name, trademark, manufacturer, or otherwise, does not necessarily constitute or imply its endorsement, recommendation, or favoring by the United States Government or any agency thereof, or the Regents of the University of California. The views and opinions of authors expressed herein do not necessarily state or reflect those of the United States Government or any agency thereof or the Regents of the University of California.

UNIVERSITY OF CALIFORNIA
Radiation Laboratory

Cover Sheet
Do not remove

INDEX NO. UCRL-8153

This document contains 42 pages

This is copy 8 of 8 series A

Date January 1958

DECLASSIFIED

~~RESTRICTED DATA~~

This document contains restricted data as defined by the Atomic Energy Act of 1954. Its transmission or the disclosure of its contents in any manner to an unauthorized person is prohibited.

Issued to Information Division

~~SECRET~~

Classification

Each person who receives this document must sign the cover sheet in the space below.

Route to	Noted by	Date	Route to	Noted by	Date
<i>609</i>	<i>✓</i>				
<i>D. McPar</i>					
<i>R. Peters</i>	<i>!</i>				

DECLASSIFIED

~~SECRET~~

UCRL-8153

UNIVERSITY OF CALIFORNIA

**Radiation Laboratory
Berkeley, California**

Contract No. W-7405-eng-48

CLASSIFICATION CANCELLED
BY AUTHORITY OF THE DECLASSIFICATION
BRANCH USAEC ON 8-21-58 DATE
By B. J. Skett SIGNATURE OF THE
PERSON MAKING THE
CHANGE

THE TRIAX PINCH DEVICE

**O. A. Anderson, W. R. Baker, J. Ise, Jr.,
W. B. Kunkel, R. V. Pyle, and J. M. Stone**

January 1958

~~RESTRICTED DATA~~

This document contains restricted data as
defined in the Atomic Energy Act of 1954
Its transmittal or the disclosure of its con-
tents in any manner to an unauthorized
person is prohibited.

DECLASSIFIED

Printed for the U. S. Atomic Energy Commission

~~SECRET~~

~~SECRET~~

UCRL-8153

DECLASSIFIED

THE TRIAX PINCH DEVICE

by

O. A. Anderson, W. R. Baker, J. Ise, Jr.,
W. B. Kunkel, R. V. Pyle, and J. M. Stone

Radiation Laboratory
University of California
Berkeley, California

The Triax device is a discharge tube in which a plasma carrying a current is pinched into the form of a cylinder between two concentric copper cylinders, each of which carries part of the return current. Such a geometry has attractive features from the standpoint of stability. An extensive study of the Triax discharge has been carried out in which observations with magnetic probes, spectrographs, and efficient neutron detectors have been combined with measurements of current and voltage to give much information on the behavior of the plasma. It is clearly established that a well-pinched sheet plasma is formed. Neutrons, which have been observed in numbers up to 2×10^5 per pulse, emerge in a short burst that coincides in time with the sudden appearance of strong light from impurities and also coincides with a peculiar bump in a plot of the voltage across the tube. The nature of the neutron production has not yet been established, and although certain arguments are presented that make it not inconceivable that it is thermonuclear, a search for a nonthermonuclear origin is continuing. So far, no nonthermonuclear mechanism has been found. The importance of a suitable auxiliary starting discharge in forming neutron-producing pinches with very high currents is brought out. Advances in the art of switching large currents are described.

- 1 -

DECLASSIFIED

~~SECRET~~

I. INTRODUCTION

Theoretical considerations indicate that a flat plasma sheet of infinite extent should be stable both with respect to disturbances transverse to the current (toroidal), and with respect to longitudinal distortions (breakup into filaments) (poloidal). Consequently, two types of edgeless sheetlike discharges are being studied at Berkeley. The first of these consists of a cylindrical plasma sleeve contained between two coaxial conducting cylinders as shown in Fig. 1. The basic features of this arrangement have already been described at an earlier conference,¹ and the relative stability of the pinched discharge was amply demonstrated at that time. A theoretical analysis of the stability of the cylindrical sheet plasma* proved the existence of a "sausage mode" instability which is, however, expected to grow very slowly because of the large circumference. The other pinch device employs a disk-shaped discharge with radial current guided between flat metal plates as indicated in Fig. 2. It will be noted that this configuration is identical with the one used in the homopolar machine^{1, 2} if the external magnetic field is omitted from the latter. A significant feature of these configurations is the absence of a plasma edge; i. e. there are no regions of sharply curved magnetic field lines anywhere in these discharges. The importance of this fact for the stability is not yet fully investigated. A rectangular flat pinch tube has been constructed, however, and the behavior of a flat plasma sheet of finite extent will be studied in the very near future. At present, the original Triax has had considerably more attention than the disk without magnetic field, so that this report deals almost exclusively with this cylindrical geometry.

An obvious drawback of the sheetlike plasma is the poor compression ratio that is obtainable by pinching without excessive currents. The benefit of strong compression is, however, also abandoned in all work utilizing stabilized ordinary pinches. Besides, this disadvantage is more than outweighed by the principal merit of the Triax pinch-- i. e., some stability without the use of a stabilizing magnetic field. It has been theoretically shown† and experimentally verified (as mentioned later on in this report) that the heat transfer to the electrodes in the Triax pinch is negligible because the magnetic field is everywhere parallel to the electrode surfaces and quite strong except for a very narrow region along a central surface in the plasma. This shows linear Triax tubes with metal electrodes, which are very simple in construction, to be exceedingly interesting as hot-plasma-producing devices, even if their dimensions are very modest.

*Lloyd Smith, UCRL, private communication.

†A. N. Kaufman (UCRL Livermore), private communication.

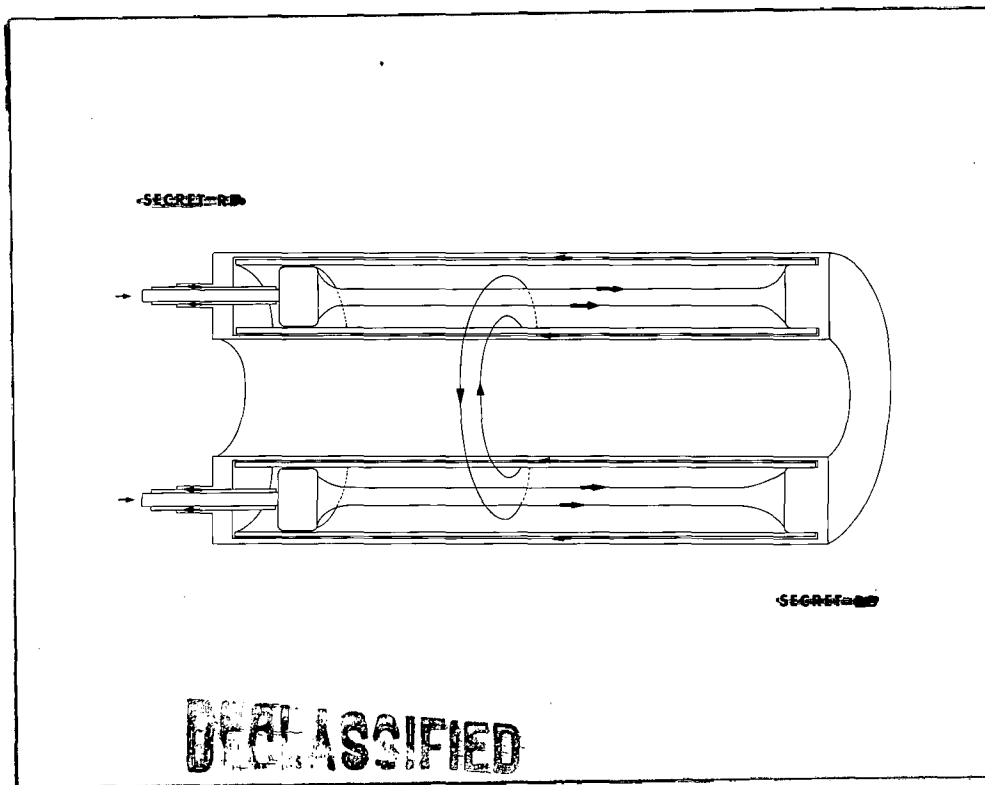

Fig. 1

DECLASSIFIED

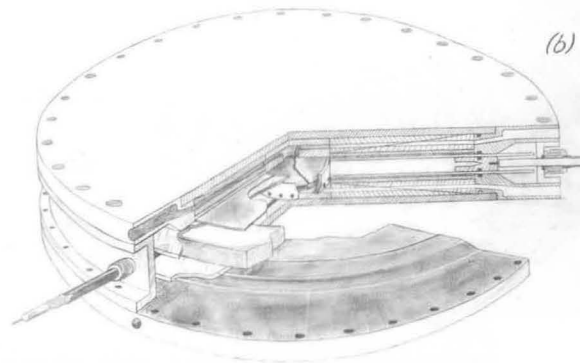
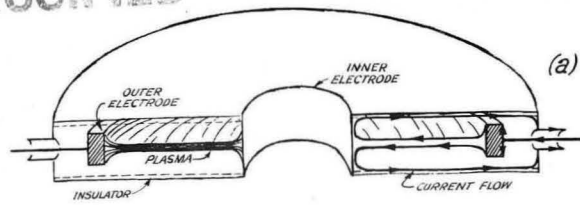

Fig. 2

II. PRINCIPAL EQUIPMENT AND TECHNIQUES

Originally, the tubes used were more than 1 meter long. Since it was found that shortening the distance between the electrodes had no effect on the discharge except for the obvious decrease in load inductance and reduction of the total volume to be heated, all the recent tests have been performed with 50-cm tubes. Even shorter ones may be used in the future. The diameter of the outer return conductor so far has always been about 10 cm. This size is determined entirely by the available quartz tubing, which is being used both as insulator and as vacuum jacket. Plans for larger sizes are already in existence. The inner return conductor usually has been about 5 cm in diameter, although recently several very significant tests have been performed with 2.5- and even with 1.25-cm-diameter inner cores. In the earlier work, which was carried out at only modest power levels, Pyrex insulators were used instead of quartz. For the future, tests with some other materials, such as pure alumina, are being contemplated. One tube has been constructed in which the metal walls rather than the insulator serve as the vacuum shell and all seals are made at one end so that the other end is completely free from gaskets. This tube has not been used yet, but it will serve for special diagnostic purposes because the end that is devoid of gaskets is easily removable and interchangeable. Finally, one tube with exposed metal walls is under construction. The advantage of such a design (if it proves possible to establish a triaxial discharge in it at all--for instance, by means of a rail discharge) will be made clear later on.

The power sources at present consist exclusively of condenser banks of various sizes made up of 1- μ f 25-kv capacitors which, as it turned out, could be charged to 30 kv, thus yielding peak currents of 30,000 amperes per condenser almost indefinitely without failing. In most of the so-called "low energy" work assemblies of 45 or 50 μ f have been used, whereas for high power levels a bank of 100 μ f is available. For other purposes, such as starting current and switch triggering, smaller groups ranging from 4 to 24 capacitors have been prepared.

In the past the switching has been accomplished mostly by means of single, large preionized spark gaps filled with air, which are fired either simply by a sudden release of pressure or which, if programmed multiple switching is desired, are triggered by a shock wave from an auxiliary small spark gap incorporated in the switch assembly. Recently a low-pressure high-level switch has been developed and the use of multiple small-sized three-electrode gaps is under study. Because the switching problem is of considerable importance much time is spent in Berkeley on the development of this auxiliary equipment. Since some of the design details and our general experience may be of some interest to others, a more complete description and discussion is included in a separate appendix.

For all connections and leads from the power supplies to the switches and to the discharge tubes RG 8U or RG 9U cables are being

used. When low inductance is important these are as short as possible and large numbers, usually one or more for each capacitor, are placed in parallel.

The gas, which is usually 99.7% pure deuterium, is always kept flowing through the systems to avoid accumulation of volatile impurities. The mechanical pumps used (Kinney) are isolated from the tubes by refrigerated baffles. The pressures, which are adjusted by needle valves in the inlet, are usually read on Alphatrons or Pirani-type gauges (Autovac), which are calibrated against a McLeod gage or a direct-reading absolute manometer (filled with Octoil-S). When desired the pressure is directly determined by a manometer reading. The pressures used so far have ranged from 50 to about 1000 microns.

III. DIAGNOSTIC EQUIPMENT AND TECHNIQUES

A. General

Both the voltage across the tube and the total current through the tube are always recorded in a conventional way (12,000:50- Ω voltage divider and a flux loop in one of the connecting cables, respectively). The signals are displayed by Tektronix 517A oscilloscopes and photographed by means of Land camera attachments. This information offers a constant check on the performance of the equipment and permits some inferences concerning the behavior of the discharges. For more detailed information special diagnostic instrumentation has been added.

B. Spectroscopy

Spectroscopic observations without time resolution were made with a 3.4-meter grating spectrograph having a dispersion of 5A/mm and yielding primarily the identity of impurities in the discharge. Observations with time resolution were made with a half-meter grating monochromator having a dispersion of 15A/mm and equipped with a type 6292 photomultiplier at the exit slit. The photomultiplier signal was fed directly to the input of a Tektronix 517A oscilloscope through a 50-ohm cable and gave 1 cm deflection per ma anode current. The voltage on the photomultiplier was set to give a few per cent noise as precaution against space-charge limitation. Amplitude of 'scope trace was adjusted by varying the amount of light entering the monochromator. Observations included time of appearance of impurity and deuterium lines, and profiles of deuterium lines broadened by Stark effect. The profiles were obtained by firing successive shots at different settings of the monochromator. Under certain conditions of operation the reproducibility from shot to shot was sufficiently good to yield very satisfactory profiles.

The line of sight into the discharge was in all cases perpendicular to the axis of the Triax tube through a hole of a few mm diameter in the outer copper tube. The hole was located midway between the electrodes

except in a photographic study of impurities originating from the electrodes themselves, in which case holes were provided near the electrodes.

C. Magnetic Probes

In an attempt to verify the notions developed concerning the structure of the pinch, the magnetic field distribution inside the discharge tube was determined by means of the now conventional probe technique.³ The coil used for the measurements reported here consisted of six turns of No. 42 formvar-insulated copper wire wound on a rectangular core of epon 0.13 mm wide and 2.5 mm high. Two such coils were placed side by side inside a sealed 2-mm o. d., 1-mm i. d. quartz capillary tube, and their well-twisted leads were shielded by hypodermic tubing. The purpose of the double coil arrangement was an attempt at a direct measurement of the field gradient in a single observation. The attenuation of the field gradient inside the quartz sleeve rendered this type of observation unsatisfactory, however, so that actually only a single coil was used.

For convenience of assembly the probe was introduced through the grounded electrode (rather than through the side wall). In order to reach a region nearly half-way between the electrodes the quartz tubing had to be about 25 cm long. This orientation of the probe stem, offering a maximum contact surface with the plasma (and actually representing also a maximum disturbance in the discharge) was naturally at first a cause of considerable concern. Just as in the previous investigations there was no evidence, however, that the discharge was affected in a detectable way even under these unfavorable conditions. For instance, the change in probe signal produced when a dummy probe of identical dimensions was inserted and brought close to the sensing probe was hardly noticeable. The all-over voltage and current signals remained entirely unaffected. The radial positioning of the coil was accomplished by a micrometer control swinging the probe about a pivot embedded inside the grounded electrode. The orientation of the coil axis was adjusted visually to point in the azimuthal direction. This procedure was considered adequate because, as pointed out above, considerations of symmetry alone show that only azimuthal fields can be significant while the discharge is well-behaved.

D. Neutron Detection

Two liquid scintillator tanks were built such that the Triax tube could be almost completely enclosed by the pair. However, the initial neutron production was sufficiently large that we operate with one of the tanks several yards away so that neutron bursts that are large enough to saturate the near detector can be monitored satisfactorily.

Each detector contains 8 gallons of liquid scintillator and is viewed by two 5-inch photomultiplier tubes. Signals from the last dynodes are fed directly to Tektronix 517 oscilloscopes and provide

timing and pulse-shape information. In this case the neutron-proton recoil pulses in the scintillator produce the signal. After thermalization the neutrons are captured in the hydrogen of the scintillator, producing a gamma ray that can be detected with a reasonable efficiency. The photomultiplier anode signals are amplified and the capture pulses counted to obtain the number of neutrons emitted. Ten per cent of the neutrons that enter the counter are detected.

A simple collimation experiment was performed to show that the neutron production is not at an electrode.

E. Miscellaneous Studies

Aside from the above-mentioned systematic studies certain individual crucial tests were performed on occasion involving some auxiliary equipment.

At one time an electrostatic probe was used that consisted of 0.25-mm-diameter tungsten wire protruding 5 mm from a 2-mm o. d. quartz capillary and introduced through a seal in the grounded electrode. This was done in an attempt to detect a postulated electrode sheath (which could not be found) and to estimate, if possible, the resistive voltage drop along the center of the plasma.

Another method of estimating the enhanced voltage drop near the electrodes (if any) and, simultaneously, checking on the predicted low heat transfer to the electrodes consisted of the addition of one or more additional floating (dummy) electrodes in the path of the discharge. But the primary importance of this subdivision of the discharge into shorter sections served the purpose of demonstrating that the neutron yield is unaffected by this interference. Quite in general it was found that such subdivisions had surprisingly little effect on the entire behavior of the Triax pinch.

Finally, as a more direct test of the heat delivered per discharge to one of the electrodes, a fast-responding thermocouple was used ballistically. It was constructed by pressing a sharply pointed Constantan wire against the backside of a thinned-down region of the grounded copper electrode. The thin electrode region consisted of a circular copper diaphragm 6 mm in diameter and 0.15 mm in thickness mounted flush with the inside surface of the electrode and having good electrical and thermal contact with the rest of the structure. If the heat input is considered uniformly distributed over the area of this diaphragm and if it is short enough in duration to be considered impulsive, then the resulting temperature of the backside is readily predicted as a function of time and of total energy input. Conversely, when the temperature, e. g., at the center of this circular diaphragm, is measured, the amount of heat delivered to the surface is readily calculated. The experimental difficulties resulted entirely from masking of the thermocouple readings by extraneous electrical signals. Refinements avoiding the background signals have been considered,

but a crude elimination of the nonthermal (purely electrical) contribution by simple reversal of the discharge polarity and comparison of signal amplitudes has already shown that the electrodes do not receive (within the limits of accuracy of these tests--perhaps a factor of 2) more than their average share of energy if the latter is distributed uniformly over the entire surface of the tube.

IV. THE TRIAX PINCH AT LOW TEMPERATURE

A. Introduction

When the Triax pinch tubes described in Section II were operated with deuterium without preionization, well-behaved performance was observed only as long as the starting pressure was above 200 μ to 400 μ , depending on the amount of energy applied. A fairly careful study of the discharge under these conditions was undertaken using condenser banks of 45 or 50 μ f which ordinarily were not charged to more than 20 kv. In this work, therefore, the maximum energy available was about 10^4 joules per discharge, i. e. in the short (50-cm) tube about 1 kev per deuteron. Of course, only a small fraction of this energy is ever converted into thermal motion of the deuterons, so that the energy available per particle is perhaps not a significant parameter. The maximum magnetic pressure (as determined by the peak current) divided by the initial gas pressure is probably a more important figure of merit because it is this ratio which essentially limits the maximum temperature that may be contained by the pinch--or, conversely, which determines the degree of compression of the gas at a given temperature. In the typical cases that are being described in this section this ratio, which we may denote by β_0 , was always less than 5×10^4 . On the other hand, for $\beta_0 > 10^5$, i. e., when the initial pressure was relatively low and particularly when higher currents were being used, it appeared that satisfactory results required the use of a starting current, and some additional considerations had to be taken into account. These cases are being deferred to the section on high-temperature work. Of course, the rate of rise of current also affects the nature of the discharge and the simple subdivision into low and high β_0 cases is so suitable perhaps mainly because the current reaches its peak value always in about the same time (2.5 μ sec) independent of the size of the storage bank. (The reason for this constant time to peak current is the fact that the major portion of the circuit inductance is in the condenser itself and in the cables. Thus as long as the number of cables is kept proportional to the number of capacitors the "ringing" period remains unchanged.)

B. General Observations and Their Interpretation

The general behavior and the basic explanations of the Triax pinch have already been given in the previous report.¹ In order to aid the discussion a brief review is given here. In Fig. 3 typical oscillograms of various signals obtained with a 100-cm Triax are shown. This tube had Pyrex walls, a 2-inch-diameter inner conductor, a simple self-firing high-pressure spark gap connecting to 45 1- μ f condensers charged

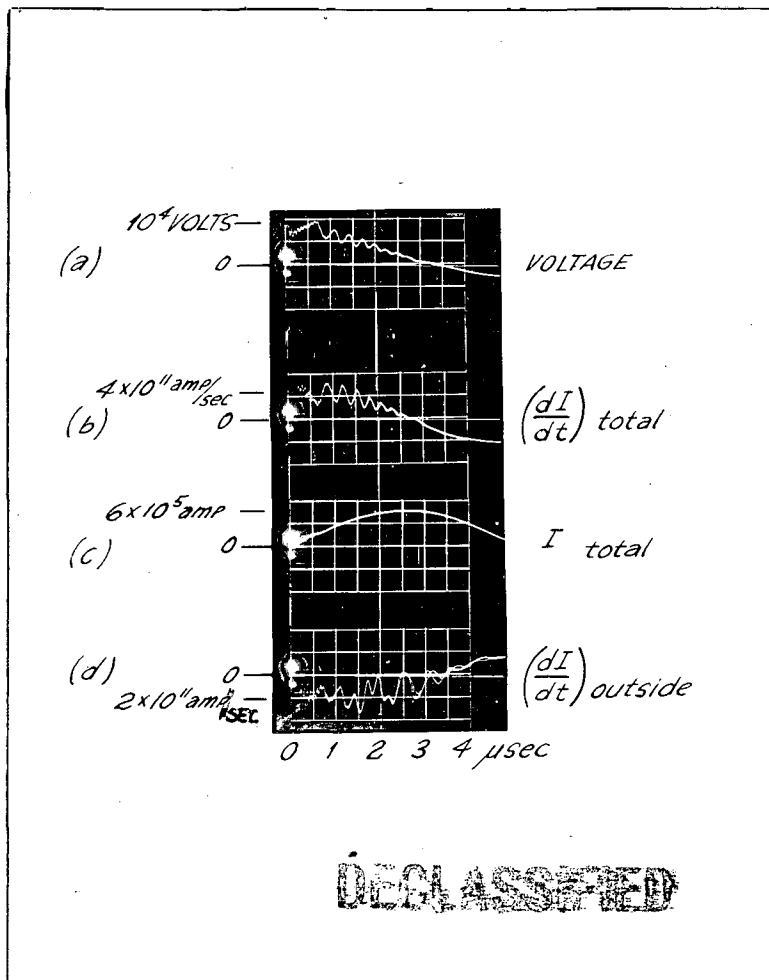

Fig. 3

to -20 kv, and an initial pressure of 475μ of D_2 . It should be pointed out that each of these pictures consists of three superimposed traces from three consecutive discharges shot under identical circumstances at about 2-minute intervals. The almost perfect reproducibility of some of these signals is apparent. All traces were taken consecutively on the same oscilloscope, the sweep of which was triggered in an identical manner for each shot. The relative timing of the different traces should therefore be very accurate and a direct comparison of the various features should be possible.

The first trace (Fig. 3a) shows the signal from the voltage divider fed directly into the oscilloscope amplifier. As in all pinch phenomena the voltage fluctuations following the initial breakdown are caused by variations in the plasma thickness. The small-amplitude oscillations are due to extraneous circuit ringing and should be ignored. In other words, because of the rather large and constant external inductance in the circuit, the total current cannot change very rapidly. Hence rapid voltage variations must be due to variations in inductance: $\Delta V = I(dL/dt)$. Moreover, it is clear that the time of a "pinch," i. e., the instant of maximum compression, coincides with the instant of maximum inductance. Or in other words, at the time of a pinch we have $dL/dt = 0$ and $d^2L/dt^2 < 0$ and the voltage is decreasing (not a maximum!). If the rebounds from the pinch are due to excess pressure inside the plasma, the points of highest compression are also the points of most rapid voltage drop, i. e., the points of inflection on the negative-voltage slopes. In Fig. 3a eight such bounces are discernible. The oscillations are smoothly damped and there is no sign of any instability. The time to reach the first pinch agrees well with predictions based on M-theory-type calculations. Of course such times are rather insensitive to small errors in mass. But for large changes in mass the fourth-root law can be shown to be in agreement with observations. The value of the observed inductance and the amplitude of the voltage fluctuations lead to the conclusion that the plasma is fairly thick.

The second signal (Fig. 3b), picked up by the flux-measuring loop (Rogowski belt) inserted in one of the cables, does not really give much new information. It measured dI/dt near a stationary conductor, hence the signal is proportional to dI/dt . It will be noticed that as far as the rapid fluctuations or bounces are concerned they seem to be almost the exact negative or mirror image of the voltage oscillations. And indeed a little thought shows that this actually always has to be the case, since $L_0(dI/dt) = V_C - V$, where L_0 is the external (fixed) inductance and V_C is the condenser voltage, which must be a smoothly varying function of time.

The time integral of this signal (i. e., when passed through an R-C integration) is proportional to the total discharge current. This is shown in Fig. 3c. The current shows very little structure, indicating that the total inductance of the circuit is not affected very much by the oscillations inside the pinch tube.

Comparing Fig. 3b or 3c with Fig. 3a, one notes that the voltage at the time with $di/dt = 0$ is small but finite. This voltage must be ascribed to a pure IR potential, since dL/dt is distinctly also very small at this point. On the assumption that the current flows in a channel about 5 mm wide, a temperature can be calculated with the help of the relationship between conductivity and temperature in a fully ionized gas across a magnetic field as given by L. Spitzer.⁴ In this particular case the temperature thus derived turned out to be about 15 ev.

The oscillogram of Fig. 3d was obtained from a small, flat loop wedged between the outer conductor and the outer Pyrex insulator. It measured the rate of change of azimuthal flux immediately adjacent to the outer return conductor; that is, this signal is proportional to the rate of change of current flowing along the outer conductor provided cylindrical symmetry is maintained. The reproducibility is probably a good indication that symmetry exists. Comparison of signals from different azimuthal positions confirmed the assumptions of cylindrical symmetry. Comparison of Fig. 3d with Fig. 3b shows a considerable difference, indicating that the current is not distributed evenly or in a constant ratio over the two return conductors. Close inspection reveals a second oscillation superimposed on the fluctuations discussed before, which were due to changes in plasma thickness. These oscillations in this instance have a smaller frequency and are interpreted as being caused by radial oscillations of the plasma as a whole. Such oscillation is expected because the first compression is not formed exactly at the equilibrium position that the plasma has to assume under the condition of both flux and pressure balance. The momentum carried by the two plasma masses moving rapidly toward each other to form the first pinch is not exactly balanced, so that some overshoot is expected. Since the discharge is completely enclosed by a continuous conducting copper wall there can be no net flux inside. This rigorously enforced flux balance results in a restoring force that pushes the plasma towards a well-defined equilibrium position. It should, moreover, be noted that as long as these radial oscillations are not very large in amplitude they do not affect the total rate of change of inductance very much and therefore do not affect the signals in Figs. 3a and 3b. (In the first order the total inductance of a balanced Triax system is independent of variations in radial position of the intermediate conductor, of course, because inductance balance implies a minimum in total inductance.)

A very significant observation to be made on Fig. 3d concerns the reproducibility of this signal. It is seen that the three superimposed traces begin to deviate from one another after about 2.5 μ sec. These nonreproducible, more or less random fluctuations are never observed on the voltage signal. Therefore they must be caused either by random variations in radial position of the plasma that do not affect the voltage very much or, if irregular fluctuations in plasma thickness are involved, these must be of a relatively fine-grain structure such that their effect on the total voltage across the entire tube always averages out. The large amplitude of the deviations occasionally found points to the former rather than the latter.

Observations with slow oscilloscope sweeps indicate that these discharges at low energy and high gas density hang together for almost one entire current cycle, i. e., they survive one current reversal without too much difficulty. It is clear, of course, that some of the hot plasma must be hitting the glass envelope when the current has low values, and impurities must be boiling out of the insulator.

The interpretations given here have been checked, in part at least, by some fairly detailed magnetic-probe studies. These were, however, always confined to the early portion of the discharge. As is discussed later, there is further confirmation from spectroscopic studies.

C. Magnetic Probe Study

The use of a single probe in a determination of the transient magnetic-field distribution as a function of position presupposes completely reproducible discharges. The extent of the local reproducibility of the Triax pinch is shown in Fig. 4, in which typical probe signals of three successive shots are again superimposed on each other. It is seen that in this case the reproducibility is adequate for about 2.5 μ sec, which here happens to coincide with the time at which the total current reaches its peak value. At higher gas densities or lower applied voltages (lower peak currents) the duration of the reliable behavior increases, whereas at lower pressures or higher power levels the reverse is true. The reproducibility of the early stages of the discharges is of course affected by the starting conditions, so that the performance of the switching device as well as the surface conditions inside the pinch tube itself are very important for this type of probe work.

In view of the foregoing considerations, the probe studies in the Triax to date have been restricted to fairly low-power-level high-density discharges. The probe signals in Fig. 4, for instance, were obtained simultaneously with those shown in Fig. 3. The current rose to a peak of about 6×10^5 amperes in 2.5 μ sec. Under such conditions the discharge was sufficiently well-behaved to render possible a fairly detailed survey of the magnetic field inside the tube. Figure 5 shows several magnetic-field distributions as a function of radial position at different times, derived from the observed probe signals. In the case shown here, the initial pressure was 1000 μ and the tube was only 50 cm long. Other conditions were identical to those of Figs. 3 and 4. In Fig. 6 a three-dimensional view of the current density as a function of both radial position and time is displayed extending over the first 1.5 μ sec of the discharge. The nature of the pinch and the existence of a rather large skin depth in the plasma are apparent from these figures.

The width of the current channel at the time of the first pinch is apparently 1/4 of the original thickness before breakdown. Since current is seen to be flowing throughout the plasma rather than on thin surface layers the particle pressure in the middle (where the magnetic field is low) will be considerably higher than near the edges. It is expected, therefore, that the particle density in the central region may

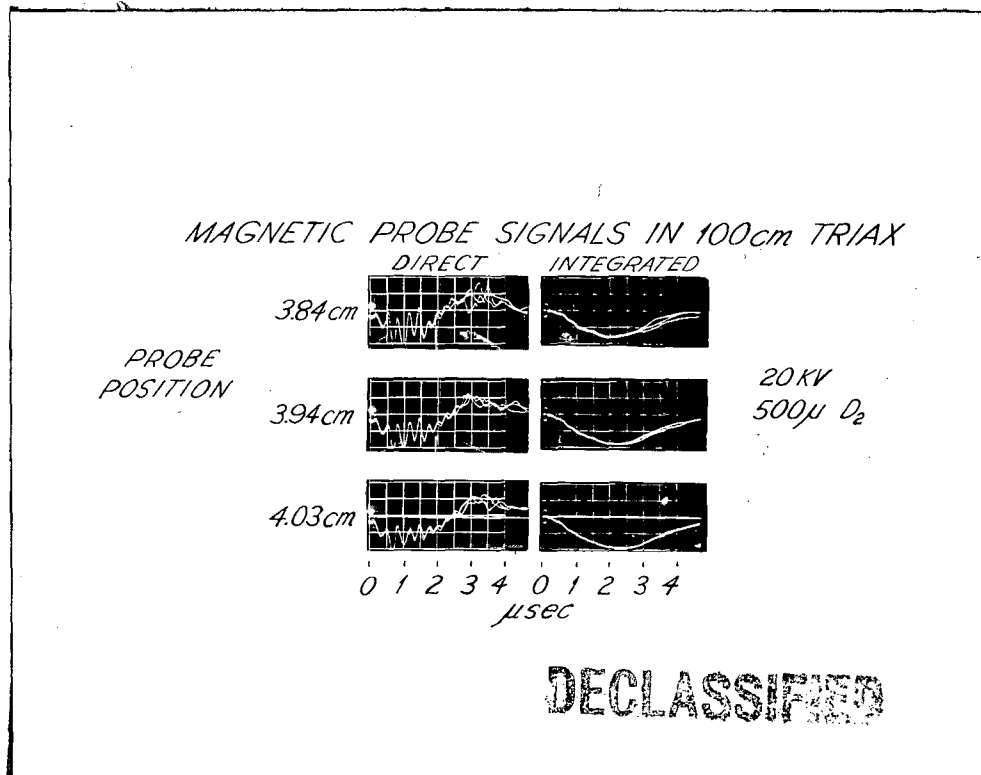

Fig. 4

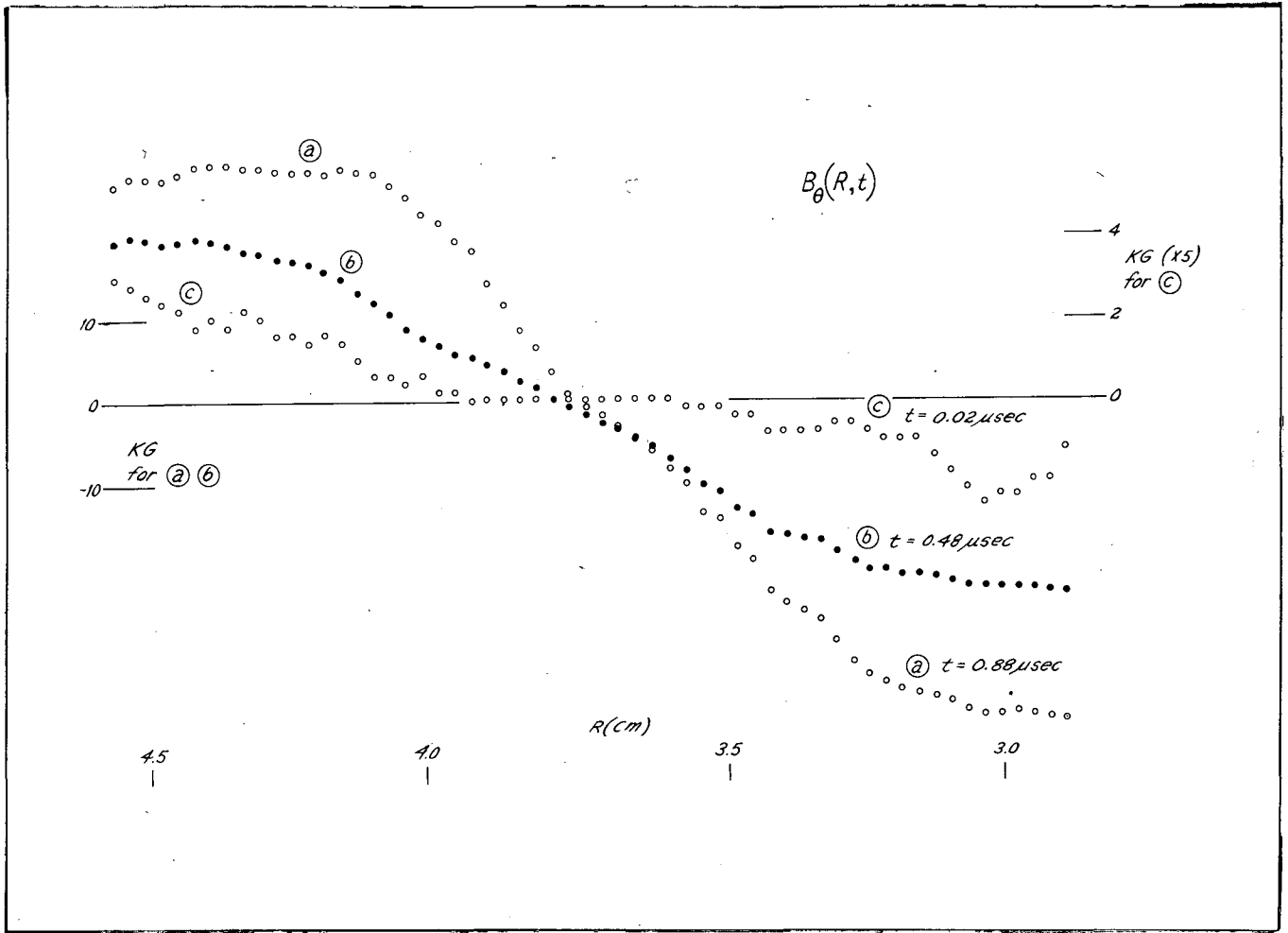

Fig. 5

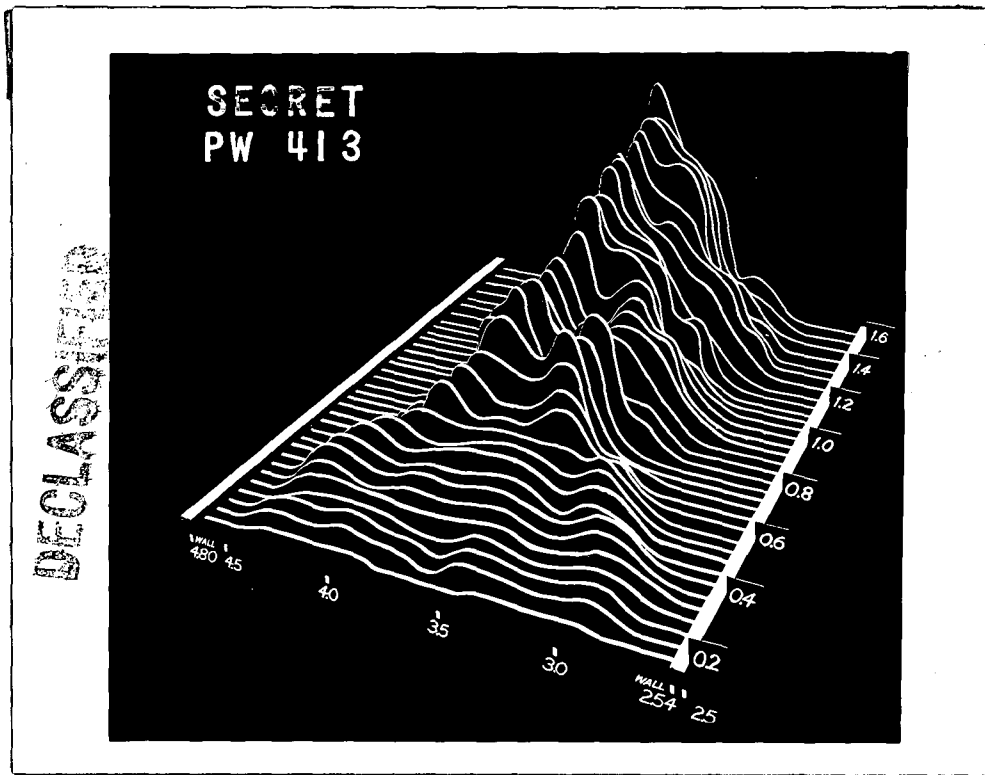

Fig. 6

be higher, perhaps by a factor of two, than the average calculated from the thickness of the current channel.

The oscillations in thickness are more easily seen in Fig. 7, where the current-channel "width" (determined by the positions of half-maximum current-density values) is plotted against time. This width, which may be considered as relatively independent of the absolute value of the current, is closely correlated with the effective inductance in the discharge. Comparison with the observed voltage, which is also drawn in Fig. 7, shows good qualitative agreement with the relation $V = V_1 + I(dL/dt)$, where $dL/dt \propto -dW/dt$. An actual numerical evaluation of the inductance as a function of time is of course possible by integration of the observed magnetic field, but uncertainties stemming from the finite size of the probe and from some statistical scatter of the data make this effort hardly worth while.

It is seen that in general the evidence from the magnetic-probe studies beautifully substantiates the notions concerning the nature of the discharge described in the preceding section. If the estimated mean compression (a factor of 6) in the center of the discharge is used for an estimate of temperature, one finds about 4 ev at the time of the first pinch and 15 ev at the current peak. Considering the uncertainties and guesswork involved, the agreement with the estimate based on the resistance may be fortuitous.

D. Spectroscopic Study

Spectroscopic observations of a low-energy Triax discharge were made with a tube of the following dimensions: outer copper tube, 10.5 cm i. d.; outer insulator (Pyrex), 9.5 cm i. d.; inner insulator (quartz) 5.5 cm o. d.; inner copper tube, 4.9 cm o. d.; distance between electrodes, 109 cm. The gas was deuterium at 500 ± 100 microns (difficulty with the pressure gage occasioned the large uncertainty). The condenser bank had 50 μ f and was charged to 20 kv. There was no preionization. The voltage and current characteristics of this tube were the same except for minute details as those of the shorter tube used for probe studies. No neutrons were detected.

Spectrograms (without time resolution) showed a line spectrum with no continuum. The principal impurities were silicon and oxygen from the insulators, carbon from O rings, and copper from electrodes. In one electrode stainless steel screw heads were exposed and in the other there were small brass plugs silver-soldered in place. All the components of the steel, brass, and solder were present in the discharge throughout the entire length of the tube and were present to a total of about 1% in the varnishlike deposits formed on both electrodes. The remainder of the deposits consisted of 1 or 2% silicon and the rest carbon.

A time-resolved profile of the deuterium line, D_{β} , λ 4860, was obtained with a monochromator and photoelectric detector having an instrumental width of 0.4 angstrom. Light passed through a small

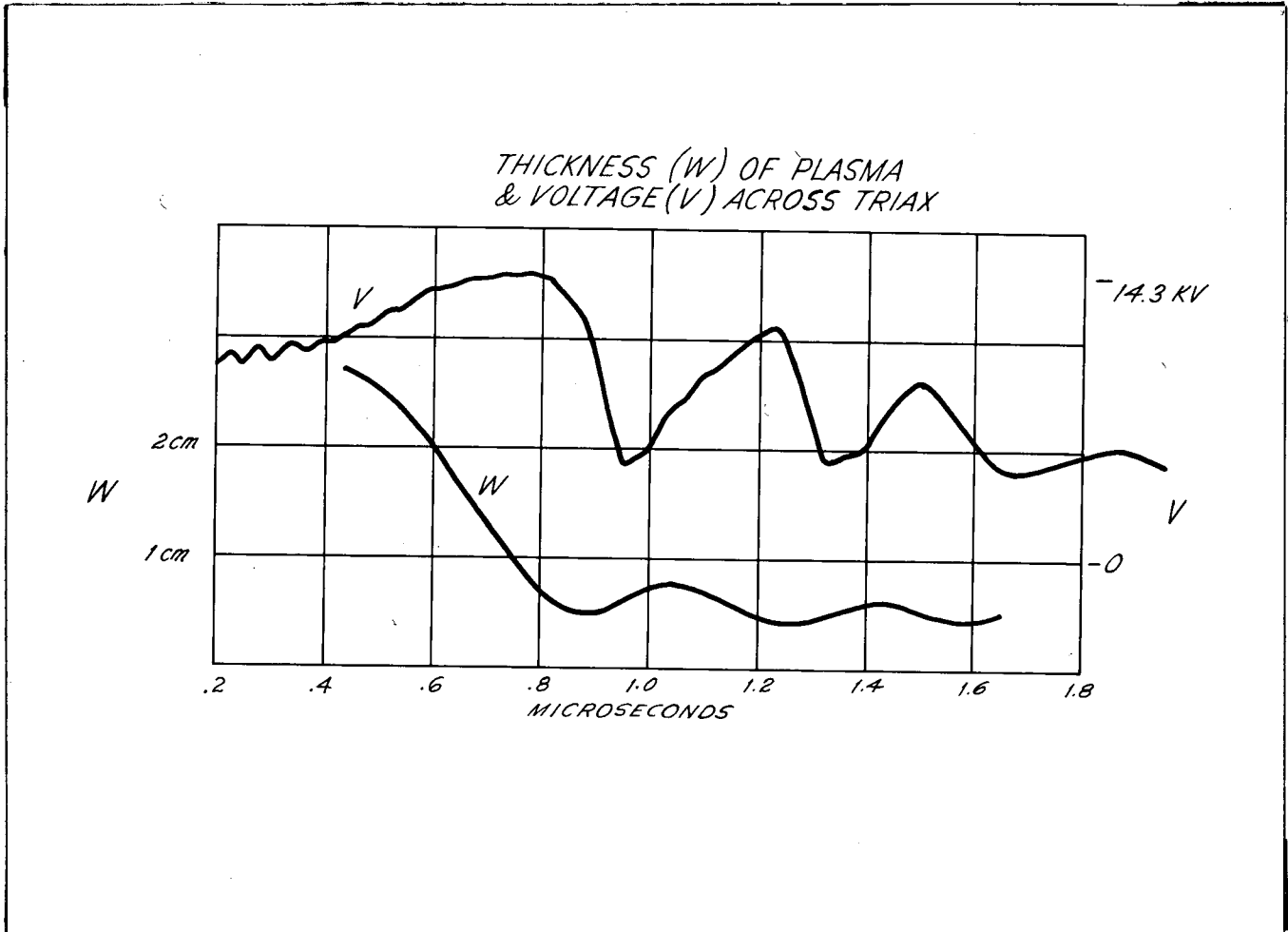

Fig. 7

hole in the outer copper tube midway between the electrodes. At each shot three oscilloscopes recorded tube voltage and current and light intensity, and the monochromator was set at a new wave length after each shot. Figure 8 shows at the top a trace of voltage against time. This curve reproduced exactly from shot to shot. Two traces of light intensity are shown, one taken at the center of the line, λ 4860.0, and one 50 A away from the center toward longer wave lengths, λ 4910. Many other traces, not shown here, were taken over a wave-length range extending 70 A in both directions from the center.

The voltage curve has already been discussed in Section IV B. In particular, the initial sharp peak in the first 0.1 μ sec results from the breakdown of the spark gap followed by the breakdown of the gas; the first pinch reaches a quasi-stationary condition at the point of inflection at 0.8 μ sec; the second pinch at 1.5 μ sec, etc. The very-high-frequency oscillations visible in the first microsecond are due to ringing in the main current circuit.

The general behavior of the $D\beta$ line is as follows. Referring to the trace of intensity at the center of the line, λ 4860.0, Fig. 8, one sees that the initial rise of intensity occurs at breakdown; at 0.25 μ sec; when the trace reaches its first maximum, the profile of the line is about 0.5 A wide at half-maximum intensity. Thereafter the profile broadens and the intensity at the center decreases, as shown by the trace, but the total intensity of the line (area under the profile) increases slightly up to 0.6 μ sec, the time of the first minimum in the trace. This behavior can be interpreted as due to shock waves converging from the two insulating walls. After 0.6 μ sec a pinch forms, and the total light intensity and width of profile increase rapidly until both reach maximum values at 0.8 μ sec, the time of the first pinch as read from the voltage curve. At this time of maximum broadening the wing of the line is visible as the first maximum in the trace at λ 4910. After the first pinch the intensity and width of the line decrease and then increase to maxima at the time of the second pinch, resulting in the second peak at λ 4910. The reduction of intensity between pinches does not appear on the trace at λ 4860, but begins to show at about 5 A from the center. The data did not yield a good profile at the time of the second pinch, but a rough estimate gives about the same broadening and about half the total intensity attained in the first pinch. There was no evidence of a broad line at the time of the third and following pinches.

The trace at λ 4860 shows a long tail of low intensity extending to more than 4 μ sec. In the absence of further evidence the authors believe that this tail is due to residual neutral atoms in the uncompressed regions outside the pinched plasma, or to some recombination at the walls. The decrease in intensity at the second pinch compared with that at the first, and the absence of light from the third pinch, are believed to be due to the reduction to zero of the density of neutral atoms in the compressed region of the pinch by the time of the third pinch.

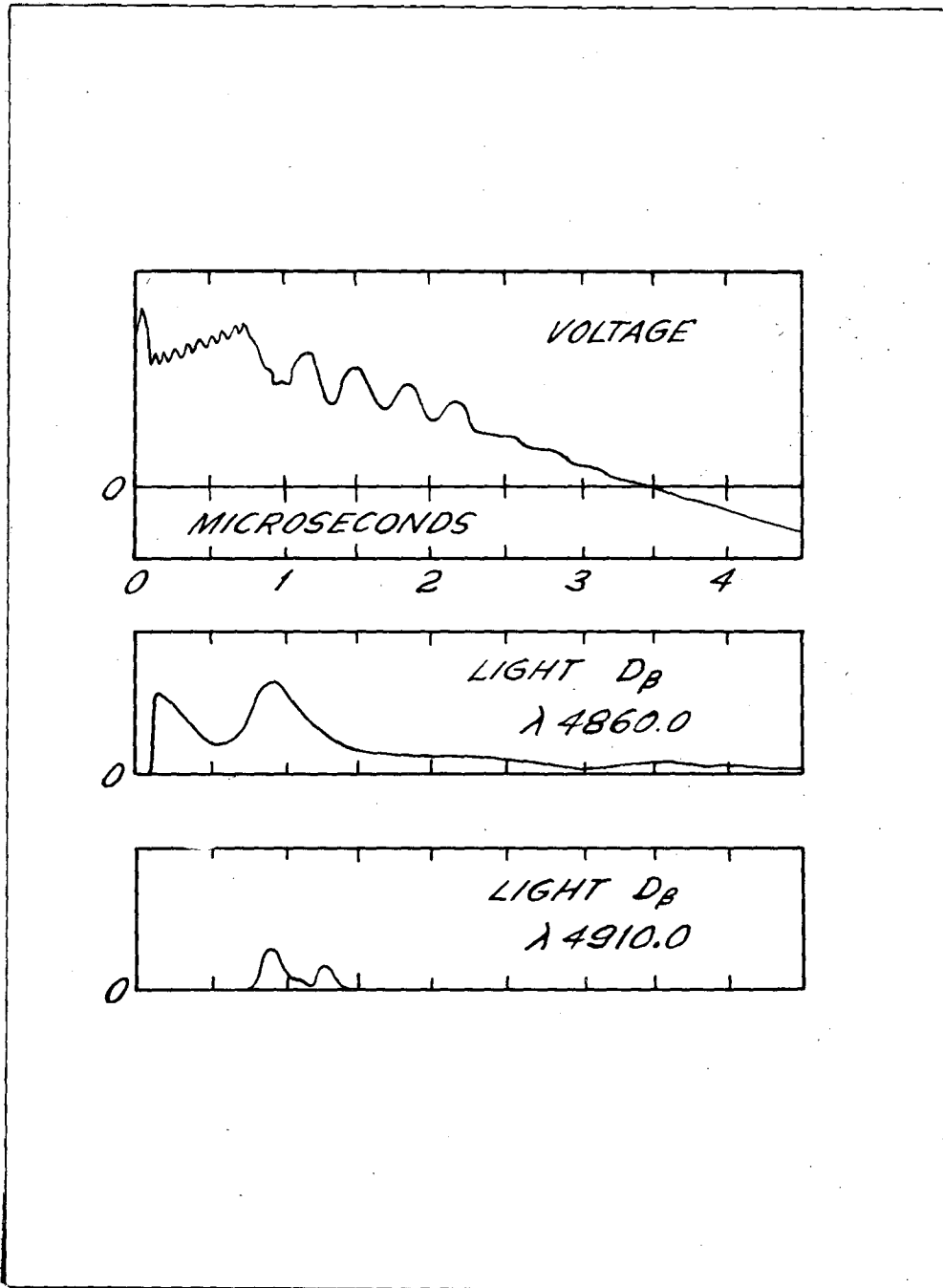

Fig. 8

Figure 9 shows the profile obtained at 0.8 μ sec, the time of the first pinch and maximum intensity and broadening. Since the profile should be symmetrical about the center, the observed points on the two wings, distinguished by circles and crosses, are plotted superimposed as though one wing were folded over about the center onto the other. The dotted curve gives an averaged profile. The solid curve is a theoretical profile according to the theory of Holtsmark⁵ for a value of $F_0 = 714$ (see Reference 5 for significance of F_0). The fit of the solid and dotted curves is good from 30 A on out from the center. The departure of the curves near the center is interpreted to mean that the light is coming from a layered plasma, some parts of which have lower ion densities than others and contribute mainly to the center part of the profile. The agreement of the two curves far out in the wings indicates that a substantial part of the light comes from the region of highest compression in the plasma, and to the extent that the simple Holtsmark theory can be relied upon, the solid curve in the figure corresponds to an ion density of 4.3×10^{17} per cm^3 . The number of neutral D atoms per cm^3 before the discharge was 3.3×10^{16} ($\pm 20\%$ owing to uncertainty in the pressure), indicating a maximum compression of some 13:1. This result is not inconsistent with magnetic-probe measurements after allowance has been made for the fact that the latter were obtained at 1000 μ whereas the profile was obtained at about 500 μ .

The above discussion covers events through the first 4 μ sec. Figure 10 shows at slower sweep speed the current and voltage and light from deuterium at λ 4860 and Si^{++} at λ 4552. A trace of silicon appears at the first and second pinches and is probably due to presence of a small amount of silicon in the discharge from the very beginning as a result of a generally dirty condition. (The outer insulator was Pyrex, which has always been a troublesome source of contamination.) At 5 μ sec, as the current nears its first zero, the plasma appears to strike the walls, giving rise to a substantial amount of silicon and some recombination of deuterium. As the current builds up in the opposite direction the pinch re-forms, and finally at 10 μ sec the current again becomes small and remains so thereafter; the plasma strikes the walls, giving a strong silicon emission, and the deuterium recombines and gives prolonged emission from a low-current discharge.

V. THE TRIAX PINCH AT HIGH TEMPERATURE

The Triax tube that is 109 cm between electrodes and whose performance at 20 kv has been described in Section IV in connection with spectroscopic observations was operated with a condenser bank of 100 μf charged to 30 kv and at a variety of pressures, in a search for neutron production. None was found, and two reasons were immediately apparent. First the voltage signals indicated that at initial pressures below 400 microns pinches were not well formed; second, the outer insulator, being Pyrex, gave rise to excessive impurities. It was desired to work at pressures of about 100 microns in order that the smaller amount of gas could reach higher temperatures. Previous

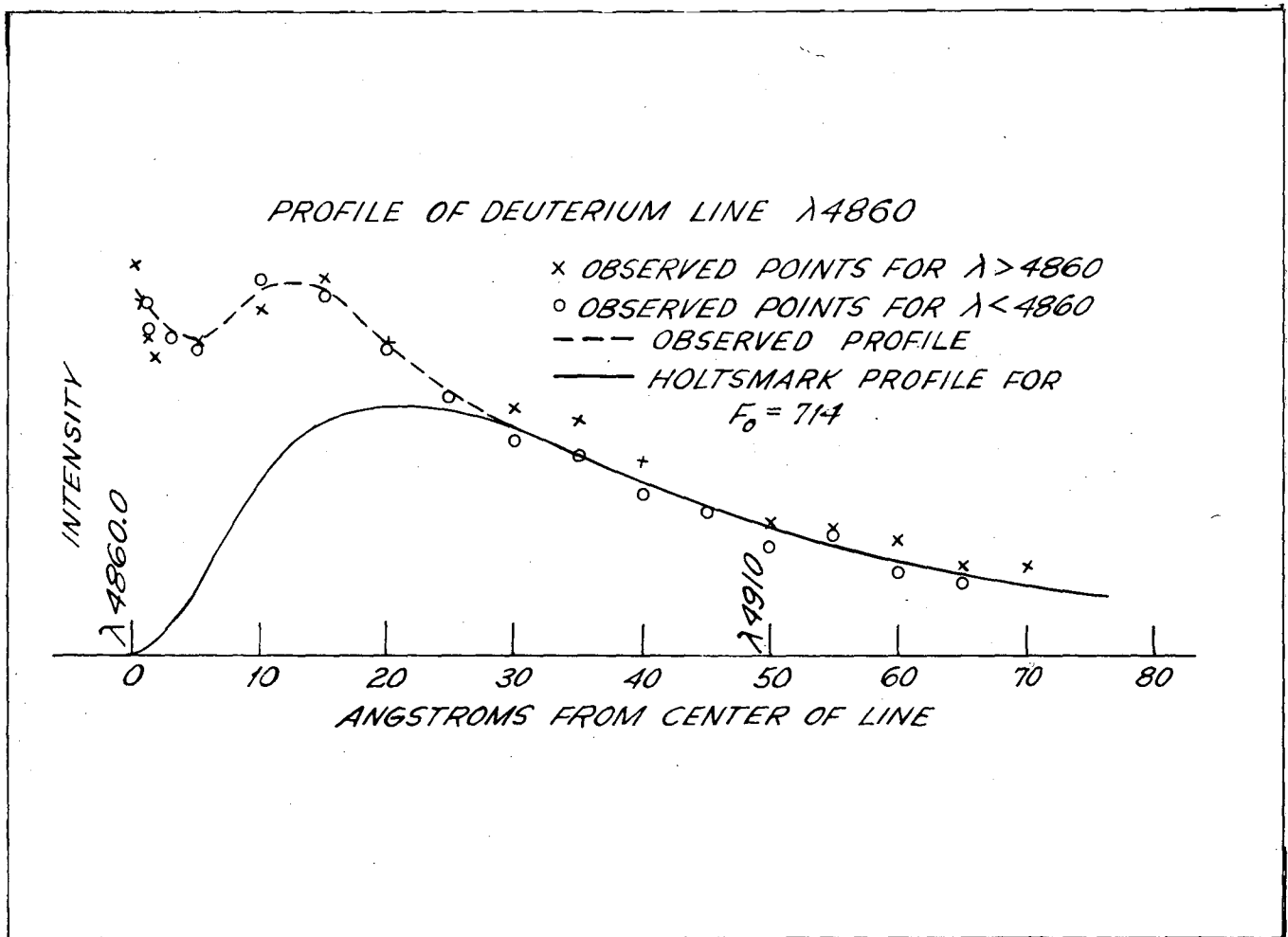

Fig. 9

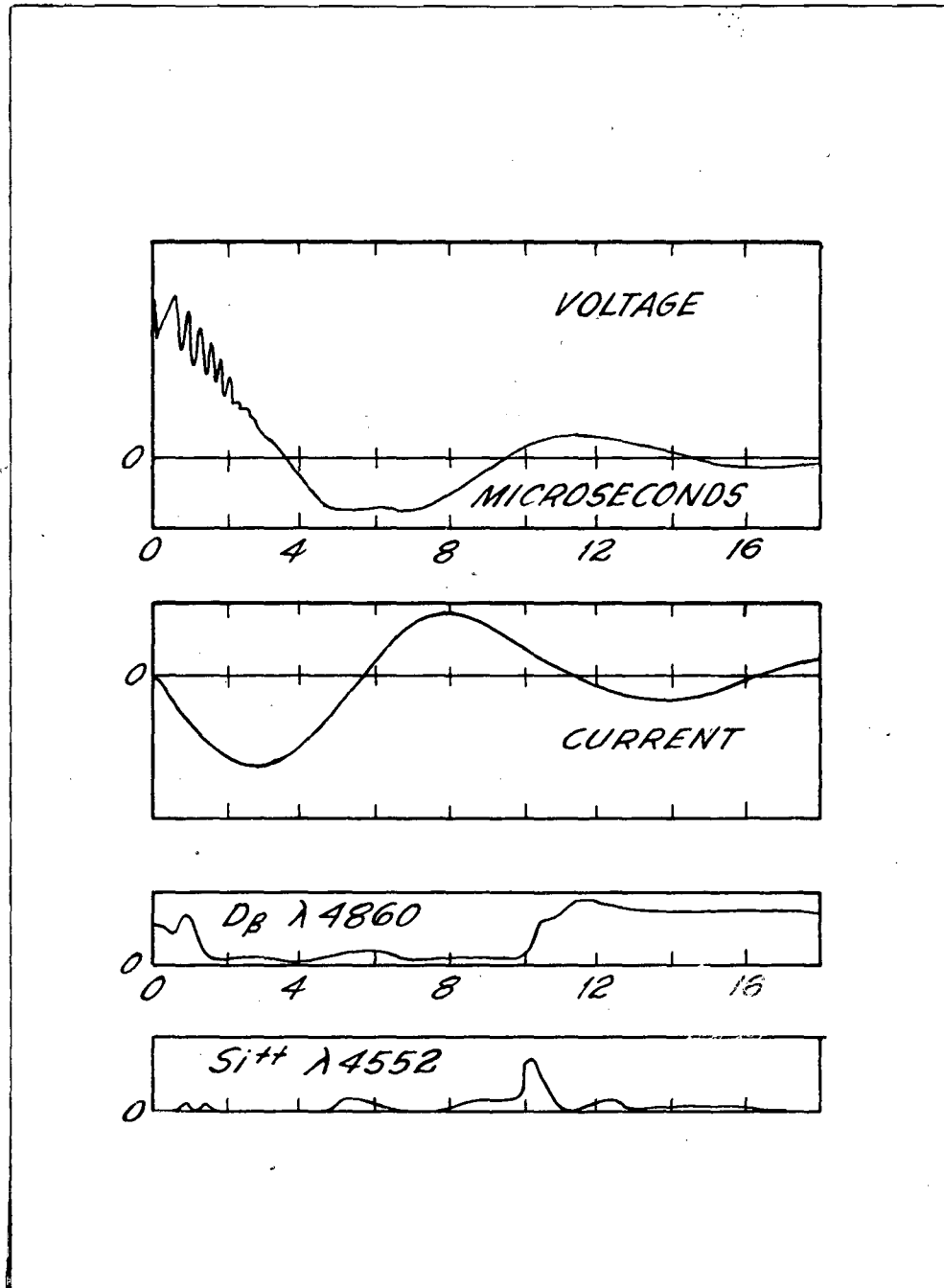

Fig. 10

experience with a dynamic pinch operated from a fast water condenser⁶ showed that under certain conditions a low-energy starter discharge which would ionize the gas and begin the formation of a pinch before the main current was switched on resulted in good pinching, whereas no pinch would form without the starter discharge. This idea was carried over to the Triax work.

The requirements on a starter device are that just before the firing of the main discharge a plasma will have been created having a temperature of about 20 volts and conducting a current of such magnitude that the magnetic pressure approximately balances the mechanical pressure, so that there is little or no mechanical pressure against the walls. However, pinching should not have progressed to any extent. Some discussion of these conditions has been given by Colgate.⁷ To achieve the desired conditions requires the design of a power supply so matched to the discharge tube as to give an appropriate magnitude and rate of change of current. Work remains to be done in finding the ideal solution for the Triax device, but rather satisfactory results have been obtained by the means described in the following paragraphs.

In view of the two difficulties mentioned earlier, a new tube was built having an outer copper tube of 10 cm i.d., an inner copper tube of 5 cm o.d., and 50 cm between electrodes (dimensions are approximate). Both insulating tubes were quartz. Switching apparatus, which will be described in an appendix, was developed which allowed firing a starter current for a predetermined length of time and then firing the main current. The power supply for the starter consisted of a small condenser bank in series with an inductance. The size of the bank, the charging voltage, the inductance, and the time of firing the main discharge were all varied, and optimum conditions were established from studies of electrical wave forms and production of neutrons. The best results were obtained with a bank of 16 μf charged to 20 kv and discharged through an inductance giving a peak current of 40,000 amp. The main bank is fired at 13 μsec , the time of the first maximum of the current. Figure 11 shows traces of voltage across and current through the tube, and intensity of the spectrum line D_3 of deuterium at λ 4860. The traces were taken without firing the main bank and with an initial pressure of 75 microns. The light intensity shows breakdown at the beginning followed by a series of peaks and valleys. The peaks occur at the times of zero current and voltage. It is believed that this light is primarily the result of recombination at the walls and that in the sequence of events following the initial breakdown the gas becomes highly ionized each time the current is large, and simultaneously the magnetic pressure largely relieves the pressure of the plasma against the walls, thus reducing the rate of recombination. Each time the current passes through zero the magnetic pressure does likewise, and the plasma exerts high pressure on the wall with consequent high rate of recombination.

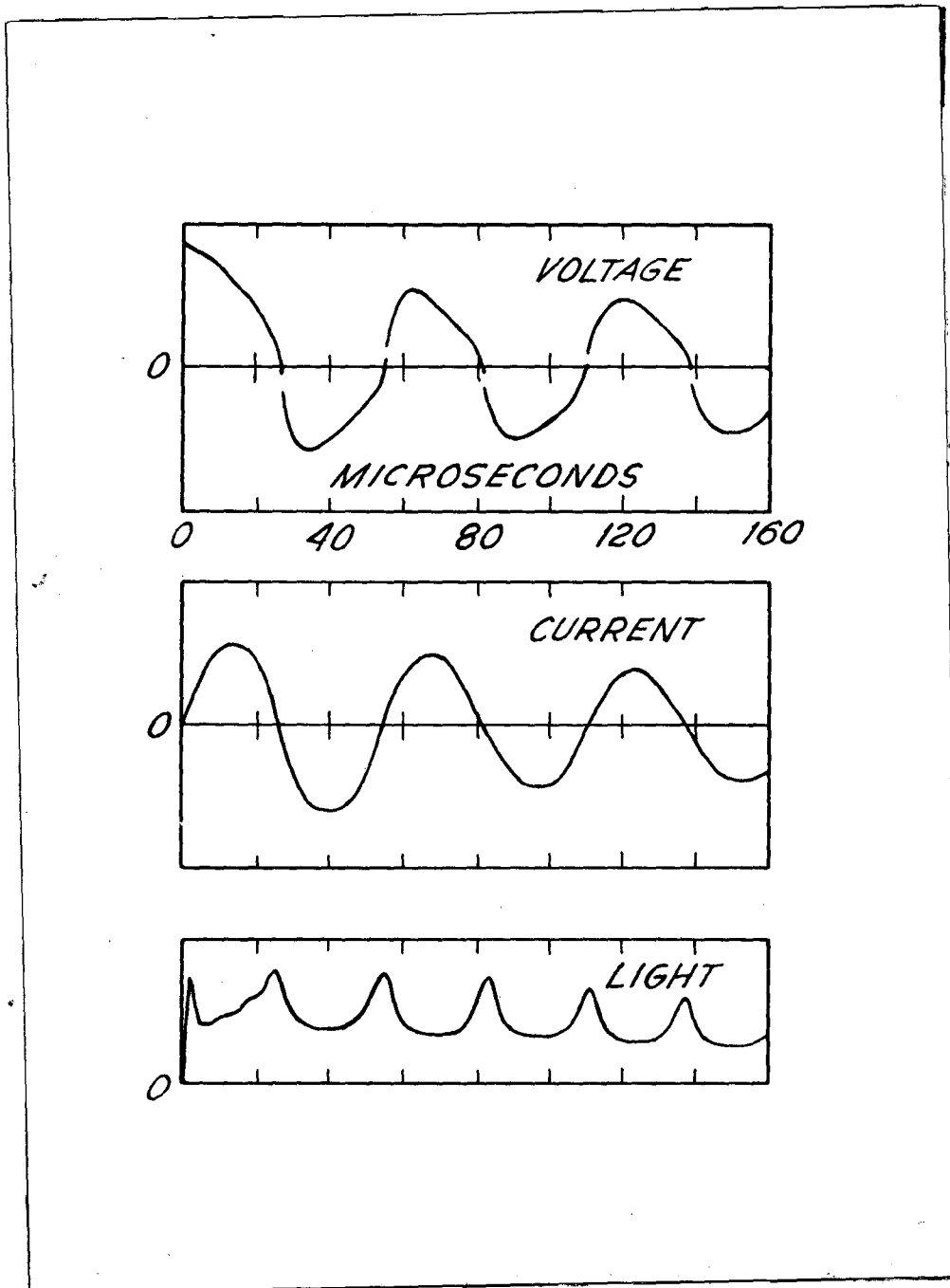

Fig. 11

When the tube is operating normally (with main bank firing) no impurities are introduced by the starter current. However, the interesting phenomenon has been observed that firing many shots of starter current only, i. e., with no main current, results in a gradual build-up of silicon in the spectrum, but that one or two shots with the main current completely removes the silicon lines from the spectrum of the starter discharge.

The effect of the starter current on the formation of pinches when the deuterium pressure was 140 microns and the main bank of 100 μ f was charged to 22.5 kv is shown in Fig. 12, in which the upper trace was taken with starter and shows good pinches, whereas pinching is not evident in the lower trace, taken under identical conditions except for omission of starter. (The high-frequency damped oscillations are due to ringing in cables, as mentioned in a previous section.)

With the optimum timing of about 13 μ sec duration for the starter and an initial pressure of 75 microns the tube produced 2×10^4 neutrons per pulse with the main bank charged to 25 kv. In Fig. 13 the upper two traces show voltage and current with a proton-recoil signal from the neutron detector superposed on the current. The peak current for this discharge was 1.3×10^6 amperes. It will be noted that after a series of pinch oscillations of decreasing amplitude and increasing frequency (the very-high-frequency ringing should be ignored) there is a pronounced bump in the voltage beginning at 1.2 and ending at 1.7 μ sec. The timing and duration of the neutron emission coincide very closely with those of the bump in the voltage. A series of experiments was carried out in an effort to learn the significance of the voltage bump and its correlation with neutron production. These experiments, now to be described, have resulted in good arguments against any presently known instability's being the origin of the bump. Furthermore, it has not been ruled out that the neutrons may be of thermonuclear origin.

(a) If the neutrons from the Triax are assumed to be of thermonuclear origin, their number is reasonably consistent with the temperatures to be expected on the basis of the known heating mechanisms taking place in the tube, whereas such consistency was lacking in the much larger yields from the linear pinch. In the Triax tube a combination of resistive heating, shock heating, and adiabatic compression could have produced a temperature of 300 volts.

(b) Location of the neutron production has been determined only to the extent of roughly establishing that it is uniform throughout the length of the tube. This simple check rules out some of the proposed nonthermonuclear processes of neutron production.

Although it is most desirable to measure the neutron energy distribution, as was formerly done with the simple dynamic pinch, the nuclear-emulsion technique used then⁸ is impracticable at the present neutron level. At the suggestion of Stirling A. Colgate a cloud chamber

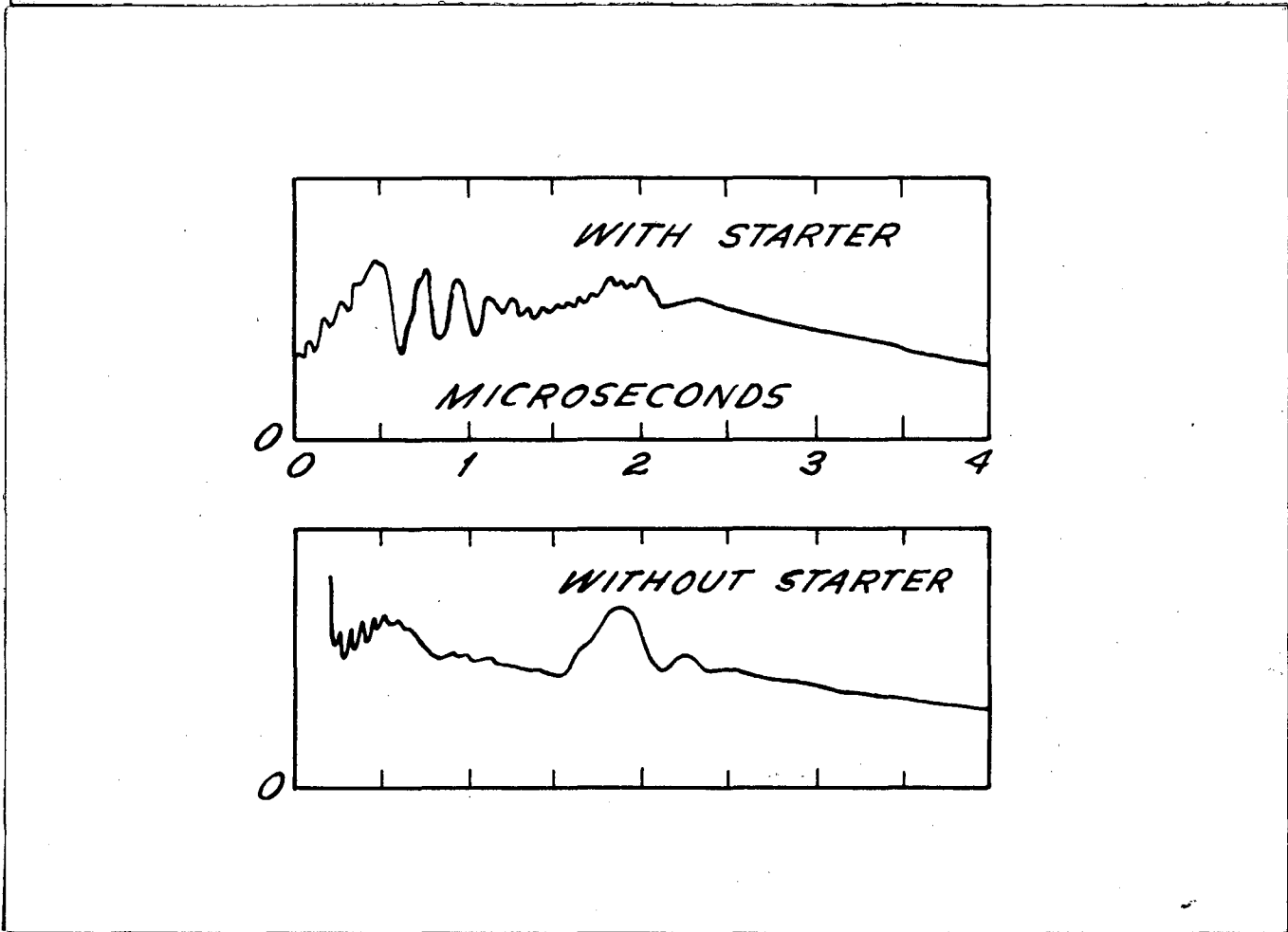

Fig. 12

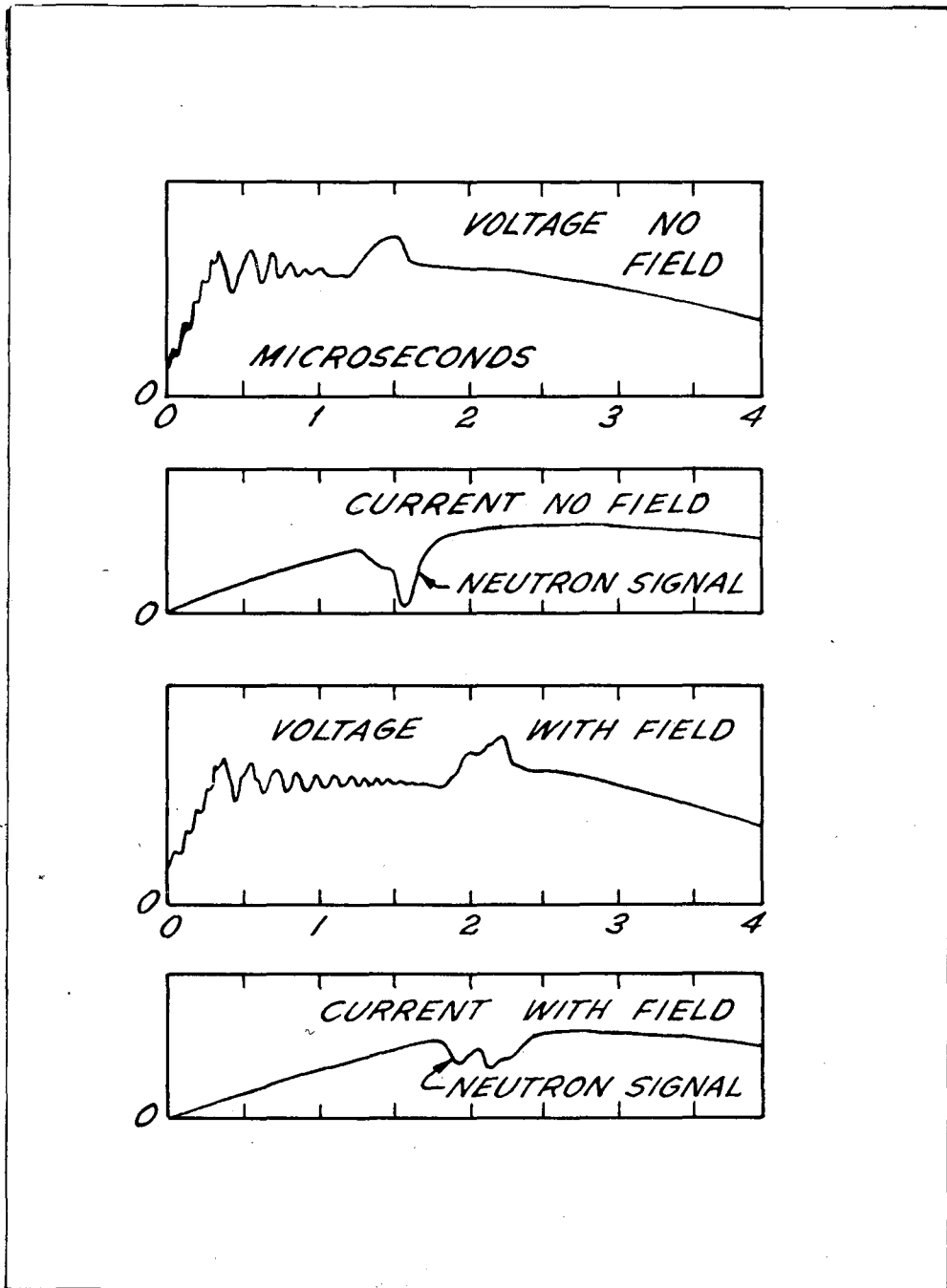

Fig. 13

is being set up which should solve this problem through its greatly improved solid angle.

(c) On the question of the bump on the voltage it may be remarked that in the linear pinch, in which it is believed that the neutrons are the result of instability, the disturbance on the voltage at the time neutrons appear consists not of a mere bump but of a series of sudden and wild transients of more than 100 kilovolts amplitude,⁸ and even showing marked reversal of polarity. The behavior in the Triax is not of that character at all.

(d) The possibility that runaway deuterons were traveling longitudinally through the central portion of the plasma where the magnetic field is zero or very small was ruled out by effectively shortening the length of path available for runaway without shortening the length of the region available to the discharge. This result was achieved by inserting two annular bulkheads of sheet copper, held between the insulating tubes by friction, and dividing the tube into three sections of equal length. The presence of these annuli, which floated electrically, had no effect on voltage, current, and neutron production. Since the annuli effectively add cathodes and anodes, the unchanged voltage behavior seems to rule out the formation of sheaths at the electrodes. Electrostatic probes have also failed to show the presence of any sheath.

(e) A magnetic loop was inserted between the outer copper tube and the outer insulating tube with an orientation to pick up the θ component of the magnetic field between the plasma sheet and the outer conductor. The signal is shown in Fig. 14. The oscillations on the curve are due to a mode of oscillation of the plasma in which the mean diameter of the plasma cylinder alternately increases and decreases. These oscillations continue without interruption to times later than that of the bump in voltage.

(f) A longitudinal magnetic field of 200 gauss was added to the Triax tube, with the result shown in the lower two traces of Fig. 13. The bump in the voltage and the burst of neutrons have been moved to a later time, but the number of neutrons remains as before.

(g) One of the essential ideas of the Triax design is the stability to be expected with a sheet plasma confined between conducting walls, and this stability, at least with respect to certain modes, should be greater the closer the walls are to the plasma. If, on the other hand, the separation between the conducting walls were increased it might be found that instabilities, if present, would be enhanced. For following up this idea a tube was built with increased separation between conducting walls, but it did not show any such enhancement, and this fact in turn was taken to imply that no instability of a type requiring the proximity of conducting walls for its suppression was present. In addition, the study of the behavior of the tube led to important discoveries bearing on the general nature of the Triax discharge, which will now be described at length.

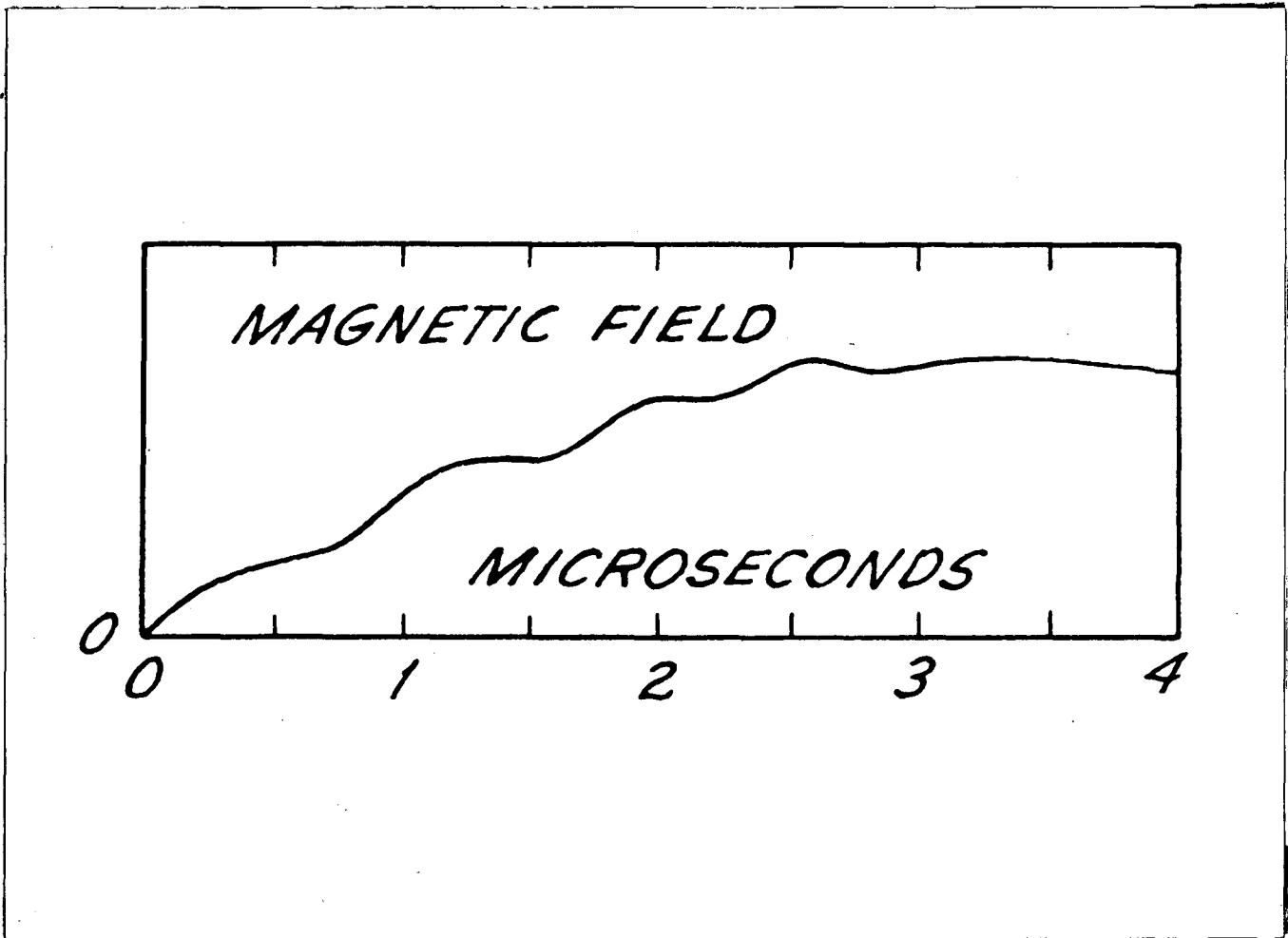

Fig. 14

The new tube had the same dimensions as the one last described except that the diameter of the inner conductor was reduced from 5 cm to 2.5 cm and the inner insulator was also reduced in diameter, so that the width of the channel available to the plasma was substantially increased. The behavior of the voltage across the tube was considerably altered, as shown by the top trace of Fig. 15, taken at 75 microns initial pressure and with the main bank charged to 20 kv. Starter current was used as before. The details of this new voltage curve have not yet been fully interpreted, but seem consistent with the idea of a superposition of two modes of oscillation of the plasma: one in which the inner and outer boundaries of the plasma approach and recede from each other (pinching), and another in which the two boundaries move always in the same direction and cause the mean radius of the plasma cylinder to oscillate about a mean value. It appears that a bump is still present but is not significantly larger than in the original tube, whereas it was expected that it would be much larger if the bump were due to instability. The second trace of Fig. 15 shows the current through the tube with a superposed signal from recoil protons indicating the time and duration of neutron production. Neutron yields of 2×10^5 per pulse were observed, which is an order of magnitude larger than the earlier figure, and as indicated by the figure the production begins near the end of the bump on the voltage curve. However, it must be remarked that although the relative timing of the neutron signal and the light curves (the latter to be discussed immediately) was carefully checked, a check of the timing of the voltage signal relative to the neutrons was overlooked, and the final bumps on the voltage may actually overlap the neutron signal to a greater extent than the figure indicates.

The last three traces of Fig. 15 show the interesting behavior of the spectrum of the light emitted from the tube. The intensity of the light of doubly ionized silicon at λ 4552 is particularly significant, because it shows that a flood of contaminant enters the plasma just at the end of the neutron production. The light of deuterium, as represented by the line $D\beta$ at λ 4860, comes up later than that of silicon and is the result of recombination. There is a general continuum, as shown by the last trace of Fig. 15 taken at λ 4547, near the silicon line. The intensity scales of the silicon and continuum traces are the same, but their relation to the intensity scale for deuterium was not determined. The interpretation of this behavior of the spectrum is discussed later.

It has already been mentioned that the possibility that the observed neutrons are of thermonuclear origin has not been ruled out by experimental evidence. To pursue this pleasant thought a little further, it seems clear that if the temperature does actually reach some 300 volts and neutrons begin to appear, then at this same temperature another strongly temperature-dependent process must be causing a flood of impurities from the walls, which cools the plasma and stops the neutron production just after it starts. Calculations now in progress indicate that sputtering by energetic particles (perhaps neutrals resulting from charge exchange) could be the agent starting the release of impurities.

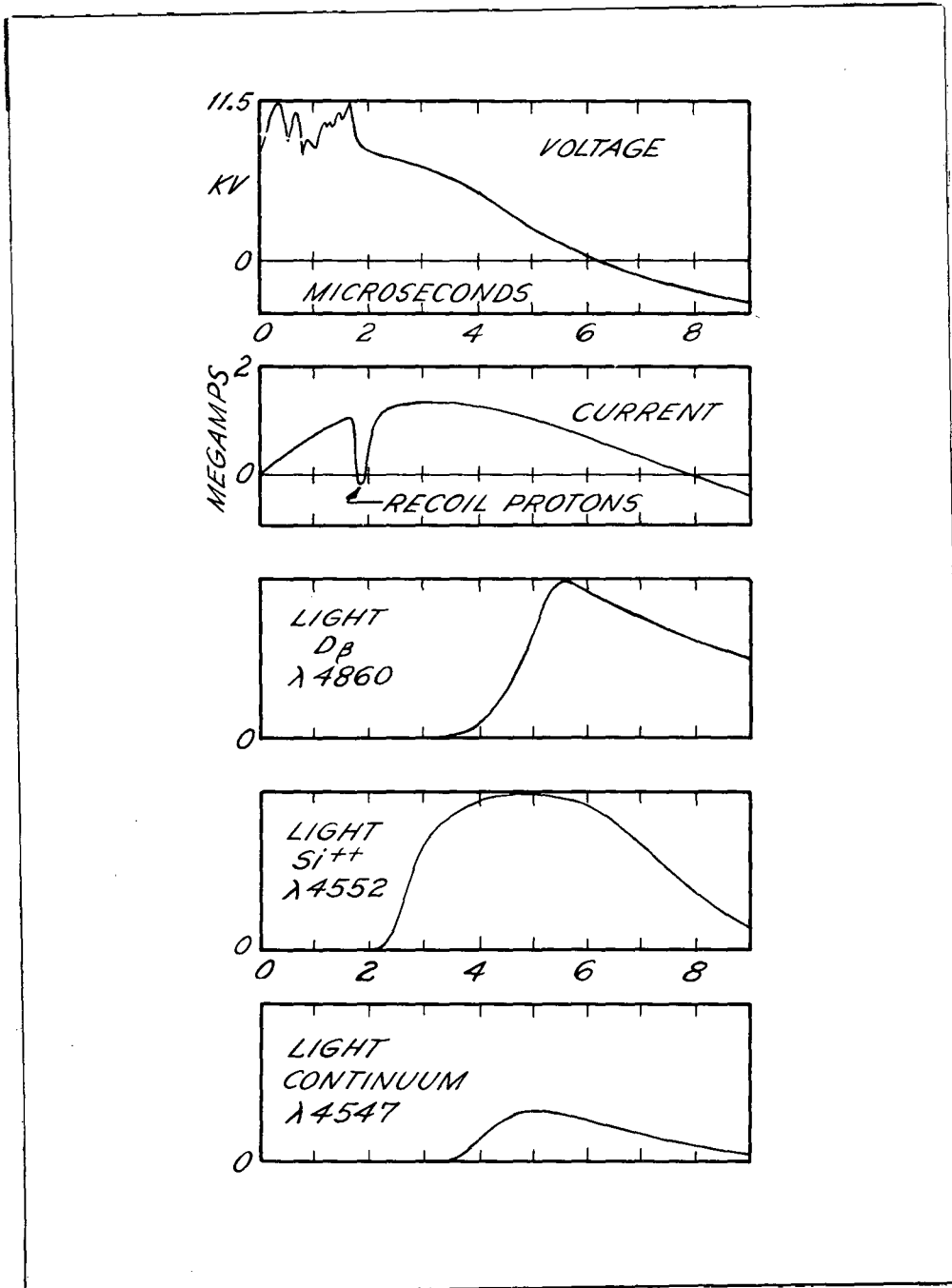

Fig. 15

Once some impurity entered a hot plasma it would give rise to strong radiation in the far ultraviolet, which would heat the surface of the insulator to the point of rapid evaporation. Arguments have been proposed whereby the bump in the voltage is accounted for as an increase in both the resistance and the inductance in the tube as the wave of impurity leaves the wall and progresses into the plasma.

The serious possibility remains that the neutrons are of some nonthermonuclear origin thus far undiscovered, and a series of further experiments is planned to shed light on the question. Observations with a streaking camera are about to be made, and some study of the radiation in the vacuum ultraviolet will be undertaken. Various modifications in size and geometry of tubes will be made. Various wall materials, possibly including a system in which the insulating tubes are omitted, will be tried. And it is hoped that the magnetic-probe technique, which has been successfully applied to low-energy discharges, can be used at high energy.

ACKNOWLEDGMENTS

The authors gratefully acknowledge discussions with Ernest O. Lawrence, Edwin M. McMillan, Chester M. Van Atta, Stirling A. Colgate, Harold P. Furth, Lloyd Smith, Allan N. Kaufman, and William Newcomb. The last three have made valuable theoretical calculations. Invaluable service has been rendered by the technicians and operating personnel associated with the project. Special thanks are due Margaret Thomas for patient and generous service in the preparation of the manuscript.

APPENDIX I

THE SWITCHING DEVICES

The subject of switches for handling the high currents encountered in our pinch devices has received a very large part of the total effort. It seems appropriate, therefore, to present some of the highlights of this work. Several approaches have been tried, but only the successful ones will be described.

Figure 16 is a sectional view of a high-pressure spark gap that has seen several months of service and thousands of operations in the range of 1 to 2 magamperes peak current. If the gap is enclosed with a metal housing, as shown, the pressurization permits more compact, lower-inductance design. The gap currently operates with air at 30 to 60 lb, with an automatic purging cycle after each usage. Connections to and from the switch are made by identical sets of 100 RG-8-U cables. Special coaxial connector fittings were developed with pressure seals of small diameter to permit a low-inductance assembly and ability to handle the high pulse currents. (These are now made on automatic machines in large lots at a cost of approximately 40 cents each and are a standard UCRL item.)

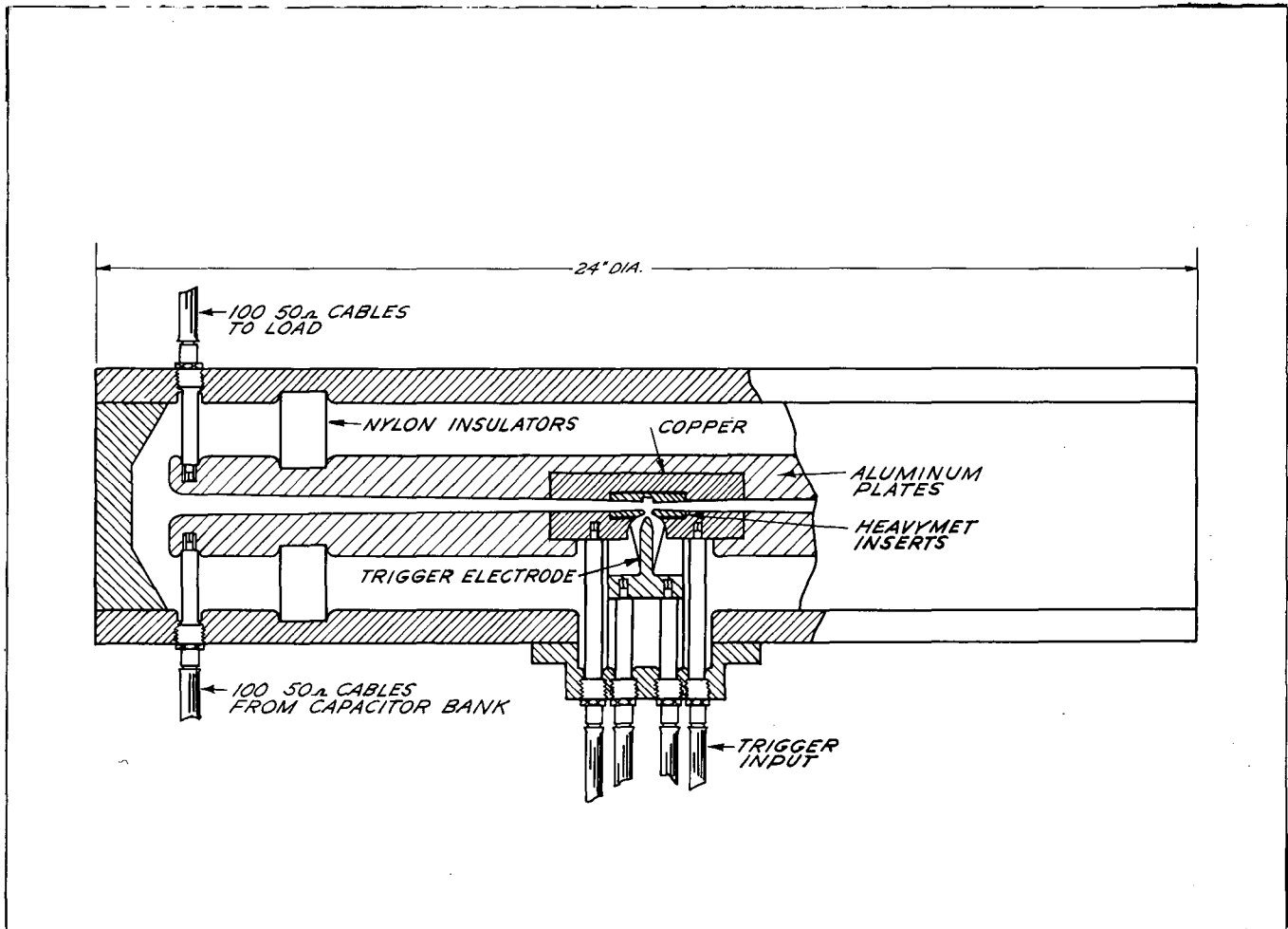

Fig. 16

Triggering is accomplished by a spark initiated at the gap shown just back of the central hole in one of the main electrodes. When this spark is made energetic enough a shock propagates from it at sound velocity that is sufficiently hot to render the main gap conducting in approximately 5×10^{-6} sec and with very little jitter. Trigger energy is supplied by a 2- μ f 30-kv condenser assembly.

Several problems peculiar to the megampere region had to be solved before a really successful gap was realized. The forces where the main spark occurs are too great for copper electrodes, therefore the central regions are made of replaceable "heavimet" pieces. This is a high-density tungsten-copper metal that stands up very well.

Experiments with smaller gaps disclosed that insulation surfaces (cable terminations) quickly became coated with debris from the spark and shorted out. Such shorts at these currents are disastrous, and much time is required to repair the damage. Pressurizing with nitrogen instead of air made the situation much worse, therefore it is probable that oxygen helps by converting the metal vapor to oxides of better insulation character. Building a very-large-diameter system, so that the insulation can be placed at a greater distance from the spark, has apparently solved this problem. So far it has not had an insulation failure of this sort at all. Actually, such a large gap can have a lower inductance than a small one if the same insulation space is used; at larger diameter the cable sections have lower impedance and more than offset the increased inductance around the spark channel. Creep paths and spacings used here are much greater than really needed, and simply reflect our desire to be free of the earlier troubles.

An annoying tendency for the spark to occur far off center was a real headache. On a "hunch" it was solved by boring holes in the electrode centers. Recently, a suggestion by Brower of General Atomics seems to be the answer. In such a large-diameter system the return-current path is very far from the spark channel and the centering forces are very weak. Locally, at the spark, however, the sloping electrode surfaces give a strong magnetic-field dissymmetry that tends to force the spark down the slope away from the center. The holes provide an inward slope that puts this same effect to work keeping the spark centered.

As a result of a recent contribution from Los Alamos, interest has again turned to the low-pressure switch. As originally conceived, this system performed well up to 5×10^4 amperes but failed at higher levels owing to condensation of evaporated electrode material on the insulator surfaces. Attempts to solve the insulator problem with baffles met with such poor success that attention soon turned to the shock-triggered (high-pressure) gap instead.

Los Alamos found, in effect, that teflon insulator surfaces remain clean when subjected to very-high-level conditions. The process by

which this occurs is apparently connected with the evaporation of a thin layer of the teflon surface that prevents the accumulation of conducting metallic deposits. Operation is accompanied by a pressure burst of 20 to 40 microns, and apparently all the material from the teflon is gaseous and can be removed by the pump. For best results the switch must be operated at high levels or the self-cleaning process is not at its best. A KC-15 Kinney pump is apparently sufficient.

A similar effect with polyethylene has been observed and used effectively in the high-level pressurized spark gap.

Having spent a great deal of time and effort trying to solve this problem, we were very enthusiastic about the new idea. A switch was immediately designed that used the evaporative insulator principle combined with ideas that had long ago been worked out and were awaiting such a development.

Figure 17 is a cross section of the first switch that was tested. After minor modifications it was operated for a total of 2000 shots at 5×10^5 peak amperes. It is designed for 30-kv operation and especially for dc voltages such as are encountered with a slowly charged capacitor bank. It operates well between 0 and 10 microns pressure and can be triggered easily by the vacuum-spark initiator. A Bostick source is unnecessary as apparently the main requirement is a copious supply of electrons and the simple vacuum spark is adequate.

There is a delay of approximately 0.1×10^{-6} sec as usually operated. The trigger pulse is obtained from a 5C22 thyatron source operating at 15 kv applied through an RG 8 U cable.

The switch is sensitive to polarity and operates with far less delay when the initiator is on the negative electrode. The delay is also pressure-sensitive, with high vacuum raising it to as much as 0.5×10^{-6} sec. A few microns of gas, preferably helium or hydrogen, lowers this time markedly and reduces jitter.

Success in holding high dc voltage is achieved by offsetting the holes in the stacked metal discs so that ions cannot be accelerated by more than the disc-to-disc voltage (approximately 5 kv in this case).

The inductance is difficult to measure but has been done with a special arrangement using 50 very-low-inductance capacitors and a minimum of connecting-lead inductance. It is sensitive to the current level and varies by a factor of approximately ten; the lower values are associated with higher current. The limiting value of minimum inductance is approximately what one calculates from the switch geometry, assuming that the conducting path is just inside the teflon insulators.

Figure 18 shows a later model of the same sort of switch that is designed for approximately the megamp level. It has an improved insulation system and is easier to assemble and service.

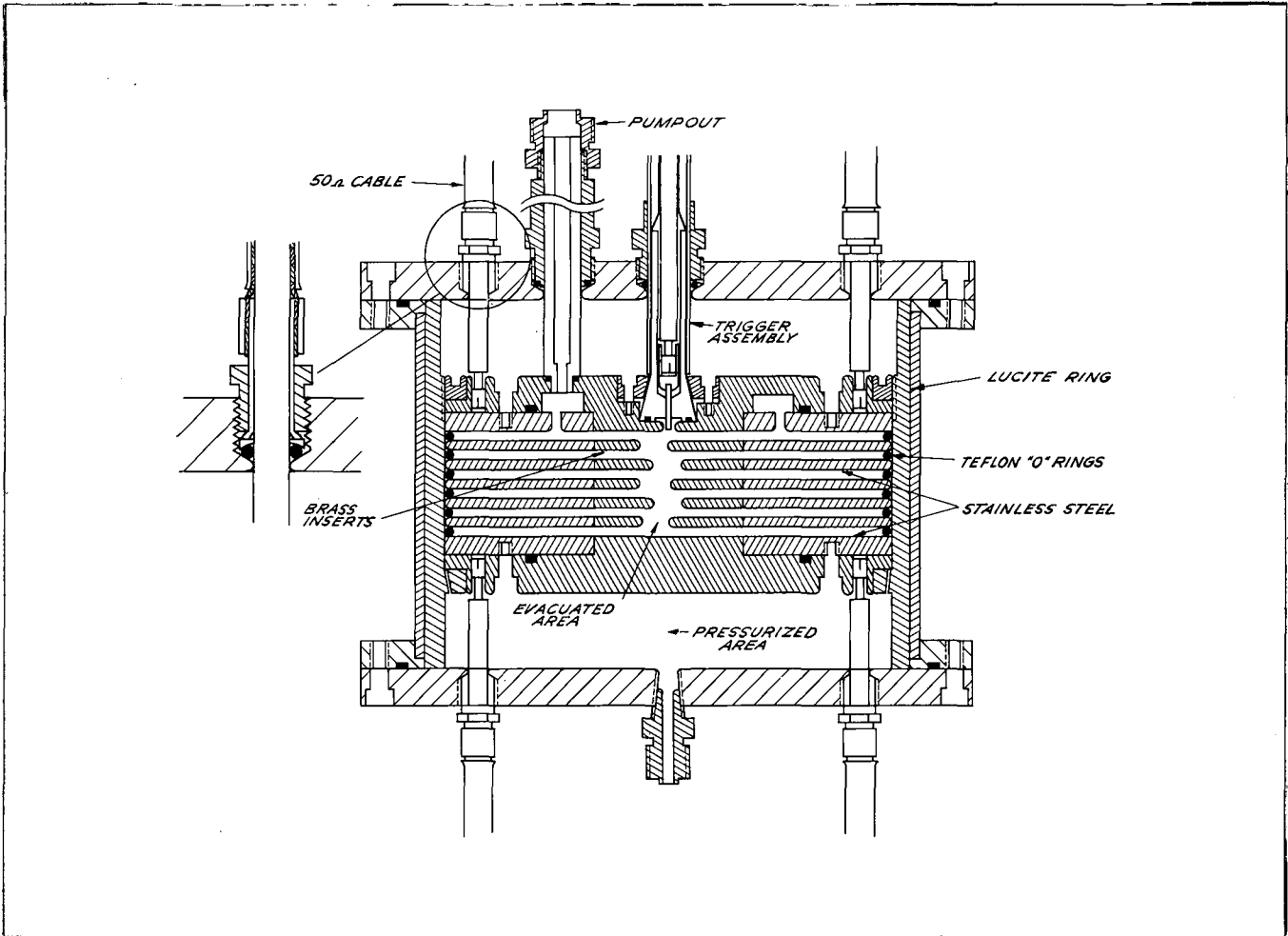

Fig. 17

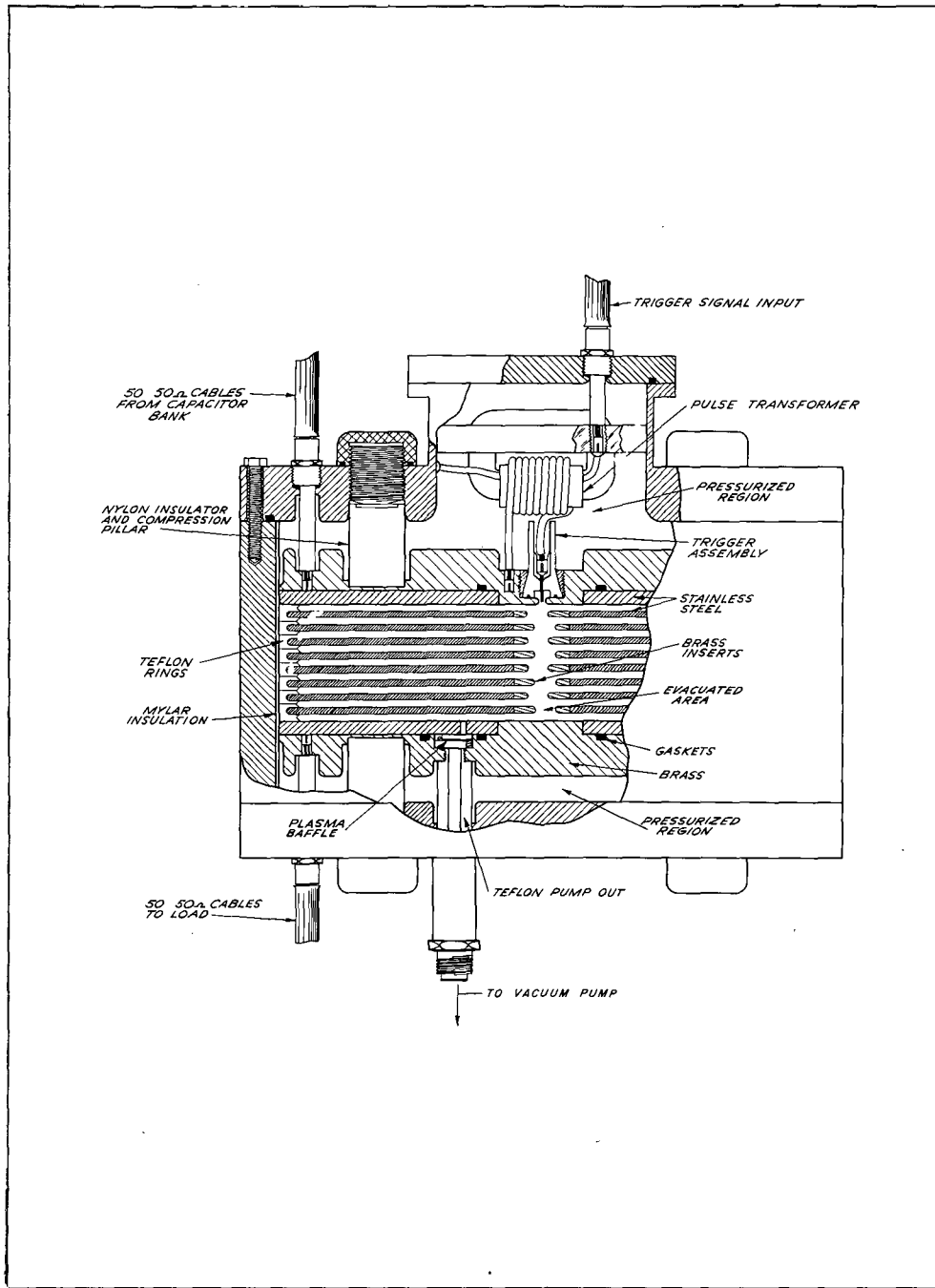

Fig. 18

Some attention has also been given to a medium-current-range spark-gap switch. By using a large number of gaps--in our case one per 1- μ f 30-kv capacitor--it is possible to hold the net inductance of the switch system to a very low value and do this without having to pressurize the gaps. In fact, normal atmospheric conditions are fine for this voltage.

When, as in our case, there are a hundred or more of these gaps to actuate in parallel to a common load, it is necessary to fire them simultaneously to within a very few millimicroseconds or the reflected voltage from the load will drop the gap voltage, and late gaps might not go at all.

At Harwell, Fitch has used a system of this nature in which very fast trigger pulses provide initial gap ionization and superimpose an overvoltage on the gap, using the impedance of the several feet of cable between each gap and the load. By supplying initial ionization and very fast (millimicrosecond range) overvoltage a gap can be made to break down in a sufficiently short time to permit the paralleling action. A similar system, using permalloy to increase the overvoltage circuit impedance, has been operated here but did not meet with favor because of the high-level transients produced. Oscilloscope measurements were badly upset for several microseconds after the gap firing.

We have found that a very simple three-electrode gap system can be used effectively to accomplish a similar switching operation and with much less of the transient problem. A two-ball gap is located at each capacitor and triggered by a fast pulse applied to a pointed rod electrode located at the mid-point of the gap and biased to half gap voltage. A 500- μ f ceramic capacitor across the balls then insures that the gap voltage remains at full value for a brief time after the third electrode breaks down to one or the other of the balls. The resulting combination of higher gap electric field and ionization from the trigger spark apparently is very effective in giving the necessary fast breakdown.

APPENDIX II

RESISTANCE AND TEMPERATURE OF THE DISCHARGE

In Section IV it was indicated that the plasma temperature of approximately 10 ev which was derived from pressure balance arguments was in agreement with the electron temperature estimated from the observed resistance of the Triax. In the case of the high temperature plasma described in Section V such a comparison was not possible because the probe measurements required for a determination of the plasma thickness were not yet available.

A thermonuclear explanation of the neutron emission requires an ion temperature somewhat in excess of 300 volts. If the plasma is assumed to be in thermal equilibrium, with the electron and ion temperatures

approximately equal and the pressures balanced, then the resistive drop across the tube can be calculated from a formula given in Spitzer⁴ and compared with the observed voltage. Some of the voltage across the tube at a time just before neutron emission can be attributed to $(d/dt)(LI)$, but about 8 kilovolts can only be attributed to IR . This is substantiated by rough Langmuir probe measurements. The possible explanation by sheath drops is excluded by the Langmuir probe and dummy electrode experiments.

Let us see what electron temperatures can be obtained if the following simplifying assumptions are made: (1) uniform current density and (2) uniform temperature throughout the pinch. We find that the thickness of the plasma sheet in the neutron producing pinch is given by the expression $\delta r \approx 10^{-3} T$ cm where T is in electron volts. The application of Spitzer's formula⁴ with a factor of two thrown in for conduction across magnetic field lines yields the result that the voltage across the tube is about 150 volts if the electron temperature is 300 electron volts. Conversely, if the resistive drop is 8 kilovolts, then the electron temperature is about 40 ev. The electron temperature obtained in this way is not sensitive to the numerical values of the observables. Moreover, it does not appear that obvious changes in the model, such as letting the current flow in a thin skin, can alter the result appreciably. If the latter statement is correct we are forced to one of the following conclusions:

1. The resistivity formula of Spitzer cannot be applied to our experimental conditions.

2. The electron temperature is certainly less than 100 volts.

If conclusion (2) is correct, then a way must be found to maintain the ion temperature at several times the electron temperature if the possibility of nuclear reactions from an ion gas near thermal equilibrium is to exist. Other laboratories with neutron producing devices appear to face the same situation.

On the other hand it is not obvious how the enormous power which is apparently delivered to the discharge if conclusion (2) is adopted is dissipated without heating the electrons. It seems unlikely that all the energy is removed by radiation. It is hoped that future experiments, such as detection of the radiation in the vacuum ultraviolet region, will shed some light on the problem.

REFERENCES

1. Anderson, O. A., Baker, W. R., and Stone, J. M., Experiments with Two New Pinch Devices, TID-7536 (Pt. 2), Book I of 2, pp. 96-102 (1957).
2. Anderson, O. A., Baker, W. R., Bratenahl, A., Furth, H. P., Ise, J. Jr., Kunkel, W. B., and Stone, J. M., The Homopolar Device; UCRL-8062, Jan. 1958. Also reported at this meeting.
3. Bratenahl, A. and Ferguson, J. P., Stabilized Pinch Probe Measurements, TID-7536 (Pt. 2), Book I of 2, pp. 110-119 (1957); Burkhardt, L. C., Lovberg, R. H., and Phillips, J. A., Magnetic Field Distributions in a Pinched Discharge, LA-2131 (1956).
4. Spitzer, Lyman, Jr., Physics of Fully Ionized Gases, Interscience Publishers (1956).
5. Unsöld, A., Physik der Sternatmosphären, 2nd ed., Berlin (1955) p. 307.
6. Anderson, O. A. and Baker, W. R., Linear Pinch Work in Berkeley, TID-7520 (Pt. 1), pp. 134-143 (1956).
7. Colgate, Stirling A., Initial Conditions for the Dynamic Pinch, UCRL-4895, May 1957.
8. Anderson, Oscar A., Baker, William R., Colgate, Stirling A., Ise, John, Jr., and Pyle, Robert V., Neutron Production in Linear Deuterium Pinches, UCRL-3725 (2nd Rev), 1957.



Figure Captions

DECLASSIFIED

- Fig. 1. Triax (schematic).
- Fig. 2. Disk Triax.
- Fig. 3. Typical wave forms.
- Fig. 4. Probe signals.
- Fig. 5. Typical magnetic field distributions.
- Fig. 6. Typical current density in Triax.
- Fig. 7. Comparison of plasma thickness and observed voltage as function of time.
- Fig. 8. Tube voltage and light intensity in the deuterium line $D\beta$ as function of time.
- Fig. 9. Observed and theoretical profiles of the deuterium line $D\beta$.
- Fig. 10. Tube voltage and current and light intensity from deuterium and silicon as a function of time.
- Fig. 11. Voltage, current, and deuterium light intensity with starter only as a function of time.
- Fig. 12. Voltage across Triax tube with and without starter as functions of time.
- Fig. 13. Voltage, current, and neutron signal when Triax tube is operated without and with longitudinal magnetic field.
- Fig. 14. Magnetic field between plasma sheet and outer conducting wall as function of time.
- Fig. 15. Tube voltage and current, recoil proton signal, and light intensity from deuterium, silicon, and continuum as functions of time.
- Fig. 16. Pressurized spark gap.
- Fig. 17. Early model low-pressure switch.
- Fig. 18. Later model low-pressure switch.

DECLASSIFIED



~~SECRET~~

DECLASSIFIED

DECLASSIFIED

~~SECRET~~