

Lawrence Berkeley National Laboratory

Recent Work

Title

R-parity violation and sneutrino resonances at muon colliders

Permalink

<https://escholarship.org/uc/item/8r55j582>

Journal

Physical Review D, 58(7)

Author

Feng, J.L.

Publication Date

1997-11-01



ERNEST ORLANDO LAWRENCE BERKELEY NATIONAL LABORATORY

***R*-Parity Violation and Sneutrino Resonances at Muon Colliders**

Jonathan L. Feng, John F. Gunion, and Tao Han
Physics Division

November 1997

Submitted to
Physical Review Letters

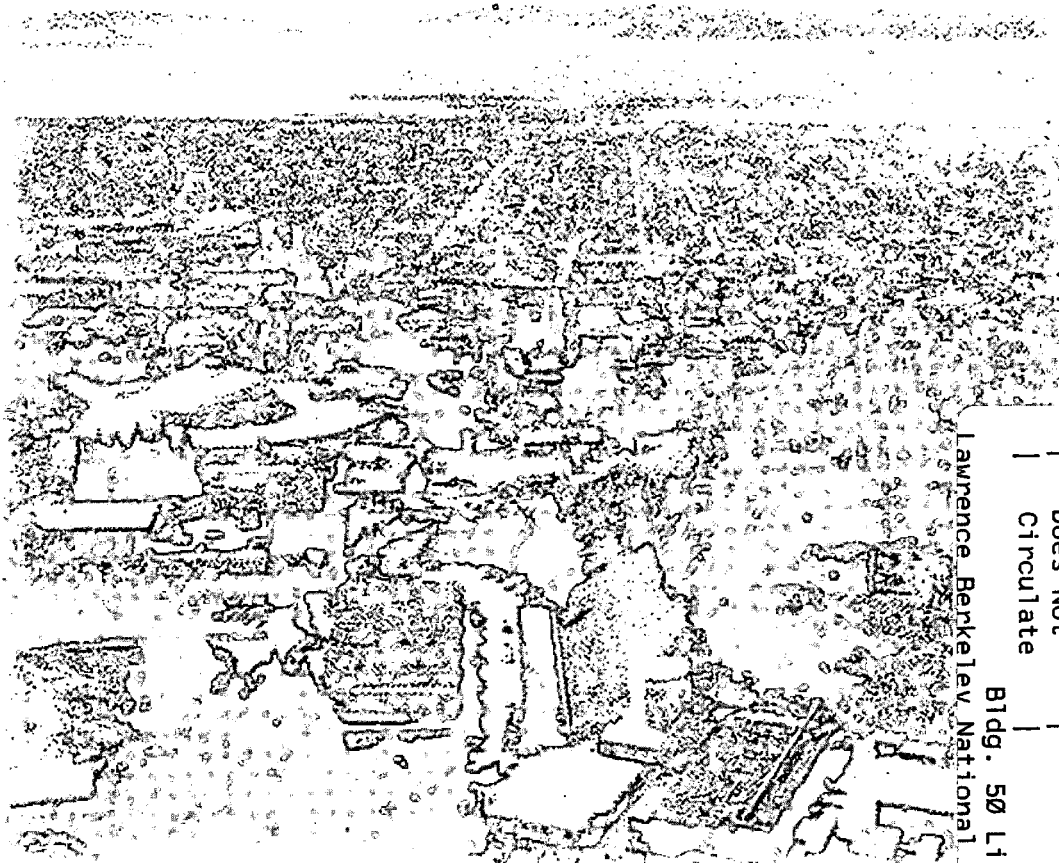

REFERENCE COPY
Does Not
Circulate

Lawrence Berkeley National Laboratory

Bldg. 50 Library - Ref.

Copy 1

LBL-41058

DISCLAIMER

This document was prepared as an account of work sponsored by the United States Government. While this document is believed to contain correct information, neither the United States Government nor any agency thereof, nor the Regents of the University of California, nor any of their employees, makes any warranty, express or implied, or assumes any legal responsibility for the accuracy, completeness, or usefulness of any information, apparatus, product, or process disclosed, or represents that its use would not infringe privately owned rights. Reference herein to any specific commercial product, process, or service by its trade name, trademark, manufacturer, or otherwise, does not necessarily constitute or imply its endorsement, recommendation, or favoring by the United States Government or any agency thereof, or the Regents of the University of California. The views and opinions of authors expressed herein do not necessarily state or reflect those of the United States Government or any agency thereof or the Regents of the University of California.

***R*-Parity Violation and Sneutrino Resonances at Muon Colliders ***

Jonathan L. Feng^a, John F. Gunion^b, and Tao Han^{b,c}

^a*Theoretical Physics Group, Lawrence Berkeley National Laboratory
and Department of Physics, University of California, Berkeley, CA 94720*

^b*Davis Institute for High Energy Physics*

Department of Physics, University of California, Davis, CA 95616

^c*Department of Physics, University of Wisconsin, Madison, WI 53706*

Abstract

In supersymmetric models with *R*-parity violating interactions, sneutrinos may be produced as *s*-channel resonances at $\mu^+\mu^-$ colliders. We demonstrate that, for *R*-parity violating couplings as low as 10^{-4} , sneutrinos can be discovered and their couplings measured to high accuracy. The excellent beam energy resolution of muon colliders is found to be especially useful for studying such resonances in certain cases.

Typeset using REVTeX

*This work was supported in part by the Director, Office of Energy Research, Office of High Energy and Nuclear Physics, Division of High Energy Physics of the DOE under Contracts DE-AC03-76SF00098 and DE-FG03-91ER40674, by the NSF under grant PHY-95-14797, and by the U.C. Davis Institute for High Energy Physics.

Low-energy supersymmetry (SUSY) provides an elegant solution to the gauge hierarchy problem and is a leading candidate for physics beyond the standard model (SM). If supersymmetric particles are discovered, the primary goal of future colliders will be to measure their properties and thereby determine the SUSY model parameters with high accuracy.

In many SUSY models, all interactions are assumed to be invariant under R -parity, where $R_P = +1$ (-1) for ordinary SM particles (superpartners). If R -parity is conserved, all superpartners must be produced in pairs and the lightest supersymmetric particle (LSP) is stable. However, renormalizable gauge-invariant interactions that are explicitly R -parity violating (\mathcal{R}_P) are also allowed by the superpotential

$$W = \lambda L L E^c + \lambda' L Q D^c + \lambda'' U^c D^c D^c, \quad (1)$$

where the lepton and quark chiral superfields $L = (N, E)$, E^c , $Q = (U, D)$, U^c , and D^c contain the standard model fermions f and their scalar partners \tilde{f} , and generational indices have been suppressed. The first two terms of Eq. (1) violate lepton number L , while the last term violates baryon number B . To avoid proton decay, L - and B -violating interactions cannot both be present.

With the couplings of Eq. (1), the scalar partners of SM fermions may be produced singly at colliders. In particular, sneutrinos $\tilde{\nu}$ may be produced as s -channel resonances at lepton colliders [1–3]. Such resonance production is unique in that it probes supersymmetric masses up to \sqrt{s} with large statistics. As sneutrinos are likely to be among the lighter superparticles, even a first stage muon collider with $\sqrt{s} = 80 - 250$ GeV will cover much of the typically expected mass range. Further, the distinctive decays of sneutrinos in \mathcal{R}_P SUSY theories ensure their early discovery at general purpose colliders. Muon colliders, with planned luminosities of $\mathcal{L} \sim 0.1 - 1$ fb $^{-1}$ /yr and exceptionally high beam energy resolutions, have been shown to provide excellent opportunities for studying narrow-width Higgs boson resonances [4]. Here, we demonstrate that, once the sneutrino mass is approximately known, \mathcal{R}_P sneutrino studies also hold great promise at muon colliders.

We may write the L -violating terms of Eq. (1) as

$$\lambda_{ijk}(N_i E_j E_k^c - E_i N_j E_k^c) + \lambda'_{lmn}(N_l D_m D_n^c - V_{pm}^* E_l U_p D_n^c), \quad (2)$$

where $i < j$, all other generational indices are arbitrary, and V is the CKM matrix. At muon colliders, sneutrinos $\tilde{\nu}_e$ and $\tilde{\nu}_\tau$ may be produced in the s -channel through λ couplings. They can then decay through λ (λ') couplings to charged lepton (down-type quark) pairs with widths $\Gamma(\tilde{\nu} \rightarrow f \bar{f}') = N_c (h^2/16\pi) m_{\tilde{\nu}}$, where N_c is the color factor and h is the relevant \mathcal{R}_P coupling. Sneutrinos may also have R_P -conserving decays, such as $\tilde{\nu} \rightarrow \nu \chi^0$, where the lightest neutralino χ^0 subsequently decays to three SM fermions through \mathcal{R}_P interactions.

The phenomenology of sneutrino resonances is thus rather complicated in full generality. However, in analogy with the Yukawa couplings, \mathcal{R}_P couplings involving higher generational indices are usually expected to be larger. We therefore focus on $\tilde{\nu}_\tau$ production through the coupling λ_{232} , and, in addition to the decay $\tilde{\nu}_\tau \rightarrow \mu^+ \mu^-$, consider the possibility of $\tilde{\nu}_\tau \rightarrow b \bar{b}$ decays governed by λ'_{333} . For simplicity, we take these two \mathcal{R}_P couplings to be real and assume that all other \mathcal{R}_P parameters are negligible. We will also consider a scenario in which the R_P -conserving decay $\tilde{\nu}_\tau \rightarrow \nu_\tau \chi^0$ is important. Fig. 1 shows representative decay widths for the three modes.

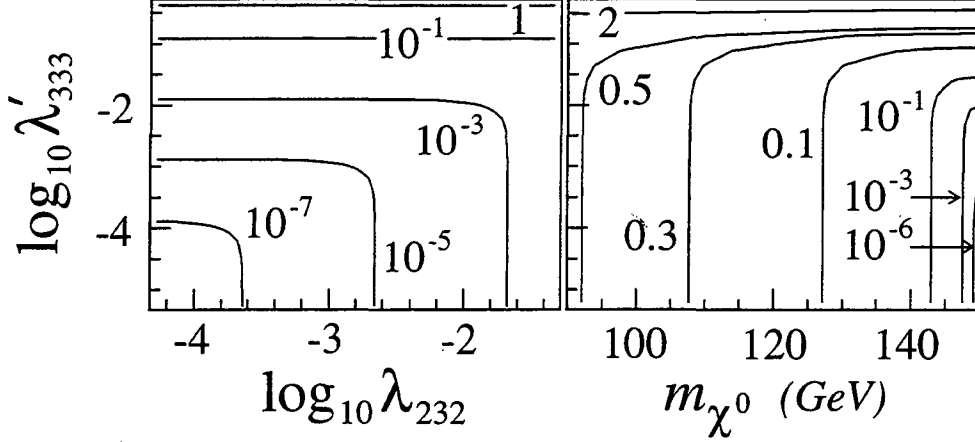

FIG. 1. Contours of total decay width $\Gamma_{\tilde{\nu}_\tau}$ in GeV (i) for $m_{\tilde{\nu}_\tau} = 100$ GeV, assuming only \mathcal{R}_P decays $\tilde{\nu}_\tau \rightarrow \mu^+\mu^-$, $b\bar{b}$ are open, and (ii) for $m_{\tilde{\nu}_\tau} = 150$ GeV, assuming that $\tilde{\nu}_\tau \rightarrow \nu_\tau\chi^0$ decays are also allowed, with $\chi^0 = \tilde{B}$ and fixed $\lambda_{232} = 5 \times 10^{-5}$. (In (ii), for any currently allowed λ_{232} , $\Gamma(\tilde{\nu}_\tau \rightarrow \mu^+\mu^-) \ll \Gamma_{\tilde{\nu}_\tau}$ unless $m_{\chi^0} > 145$ GeV and $\lambda'_{333} < 0.01$.)

The cross section for resonant $\tilde{\nu}_\tau$ production is

$$\sigma_{\tilde{\nu}_\tau}(\sqrt{s}) = \frac{8\pi\Gamma(\tilde{\nu}_\tau \rightarrow \mu^+\mu^-)\Gamma(\tilde{\nu}_\tau \rightarrow X)}{(s - m_{\tilde{\nu}_\tau}^2)^2 + m_{\tilde{\nu}_\tau}^2\Gamma_{\tilde{\nu}_\tau}^2}, \quad (3)$$

where a factor of 2 has been explicitly included to account for both $\tilde{\nu}_\tau$ and $\tilde{\nu}_\tau^*$ exchange, X denotes a generic final state from $\tilde{\nu}_\tau$ decay, and $\Gamma_{\tilde{\nu}_\tau}$ is the total sneutrino decay width. The effective cross section $\bar{\sigma}_{\tilde{\nu}_\tau}$ is obtained by convoluting $\sigma_{\tilde{\nu}_\tau}(\sqrt{s})$ with the collider's \sqrt{s} distribution. Neglecting (for purposes of discussion) bremsstrahlung and beamstrahlung, this distribution is well-approximated by a Gaussian distribution with rms width

$$\sigma_{\sqrt{s}} = (7 \text{ MeV}) \left(\frac{R}{0.01\%} \right) \left(\frac{\sqrt{s}}{100 \text{ GeV}} \right), \quad (4)$$

where the beam energy resolution factor R is typically in the range (0.003 - 0.1)%. In two extreme limits, $\bar{\sigma}_{\tilde{\nu}_\tau}$ can be expressed in terms of branching fractions B as

$$\bar{\sigma}_{\tilde{\nu}_\tau}(m_{\tilde{\nu}_\tau}) = \begin{cases} \frac{\sqrt{8\pi^3}\Gamma_{\tilde{\nu}_\tau}}{m_{\tilde{\nu}_\tau}^2\sigma_{\sqrt{s}}} B(\mu^+\mu^-)B(X), & \Gamma_{\tilde{\nu}_\tau} \ll \sigma_{\sqrt{s}} \\ \frac{8\pi}{m_{\tilde{\nu}_\tau}^2} B(\mu^+\mu^-)B(X), & \Gamma_{\tilde{\nu}_\tau} \gg \sigma_{\sqrt{s}}. \end{cases} \quad (5)$$

If only highly suppressed \mathcal{R}_P decays are present, $\bar{\sigma}_{\tilde{\nu}_\tau} \propto \Gamma_{\tilde{\nu}_\tau}/\sigma_{\sqrt{s}}$. The small values of $\sigma_{\sqrt{s}}$ possible at a muon collider thus provide an important advantage for probing small \mathcal{R}_P couplings. At a muon collider, the effects of bremsstrahlung are small (but are included in our numerical results); beamstrahlung is negligible.

There are a wide variety of low-energy constraints on λ_{232} and λ'_{333} [5]; the most stringent of these are collected in Table I. Bounds on these individual couplings may be found in the literature. Their product is most stringently bounded by B decays [3,10]. In the NDD^c diagonal basis of Eq. (2), the product is most tightly constrained by applying the bound $B(B^- \rightarrow \mu^-\bar{\nu}) < 2.1 \times 10^{-5}$ [7] to the operator $-\frac{\lambda_{232}\lambda'_{333}}{m_{\tilde{\tau}_L}^2} V_{pb}(\overline{\mu}_R\nu_L)(\overline{u}_L^c b_R)$. In the alternative

TABLE I. Upper bounds on the couplings λ_{232} and $\lambda_{333}^{(U)}$.

Coupling	Upper Bound	Process
λ_{232}	0.06 [$m_{\tilde{\mu}_R}/100$ GeV]	$\frac{\Gamma(\tau \rightarrow e\nu\bar{\nu})}{\Gamma(\tau \rightarrow \mu\nu\bar{\nu})}$ [2,6,7]
λ'_{333}	0.6 – 1.3 (2σ)	R_τ ($m_{\tilde{q}} = 0.3 - 1$ TeV) [8]
$\lambda_{232}\lambda'_{333}$	0.089 [$m_{\tilde{\tau}_L}/100$ GeV] ²	$B^- \rightarrow \mu\bar{\nu}$
$\lambda_{333}^{(U)}$	1.0 [$m_{\tilde{\nu}_\tau}/100$ GeV] ^{1/2}	$B^0-\bar{B}^0$ ($2m_{\tilde{\nu}_\tau} = m_{\tilde{b}_R}$) [9]
$\lambda_{232}\lambda_{333}^{(U)}$	0.0012 [$m_{\tilde{\nu}_\tau}/100$ GeV] ²	$B_s \rightarrow \mu^+\mu^-$

$EU D^c$ diagonal basis, the \mathcal{R}_P interactions $\lambda_{lmn}^{(U)} (V_{mq} N_l D_q D_n^c - E_l U_m D_n^c)$ generate the operator $-\frac{\lambda_{232}\lambda_{333}^{(U)}}{m_{\tilde{\nu}_\tau}^2} V_{tq}^* (\overline{\mu}_R \mu_L) (\overline{d}_L^q b_R)$, which is stringently bounded by $B(B_s \rightarrow \mu^+\mu^-) < 7.7 \times 10^{-7}$ [11]. From Table I we see that bounds on the product are highly basis-dependent. We shall not assume that λ' is diagonal in any particular basis, but only that λ'_{333} is dominant. For typical superpartner masses, appropriate limits are then $\lambda_{232} \lesssim 0.06$, $\lambda'_{333} \lesssim 1$, and $\lambda_{232}\lambda'_{333} \lesssim 0.001$.

The signals for $\tilde{\nu}_\tau$ production depend on the $\tilde{\nu}_\tau$ decay patterns. We consider two well-motivated scenarios. In the first, $m_{\tilde{\nu}_\tau} < m_{\chi^0}$, and $\tilde{\nu}_\tau$ decays only through \mathcal{R}_P operators.¹ Neglecting \mathcal{R}_P couplings other than λ_{232} and λ'_{333} , the signal is $\mu^+\mu^-$ or $b\bar{b}$ pairs in the final state. For concreteness, we consider $m_{\tilde{\nu}_\tau} = 100$ GeV.

The dominant backgrounds are Bhabha scattering and $\mu^+\mu^- \rightarrow \gamma^*, Z^* \rightarrow \mu^+\mu^-, b\bar{b}$. To reduce these, we apply the following cuts: for the $\mu^+\mu^-$ ($b\bar{b}$) channel, we require $60^\circ < \theta < 120^\circ$ ($10^\circ < \theta < 170^\circ$) for each muon (b quark). The stronger θ cuts in the $\mu^+\mu^-$ channel are needed to remove the forward-peaked Bhabha scattering. We also require $|m_{f\bar{f}} - m_{\tilde{\nu}_\tau}| < 7.5$ GeV in both channels to reduce background from radiative returns to the Z .

After the cuts above and including beam energy spread and bremsstrahlung, the background cross sections at $\sqrt{s} = 100$ GeV are $\sigma(\mu^+\mu^-) = 3.5 \times 10^4$ fb and $\sigma(b\bar{b}) = 2.0 \times 10^5$ fb. Given the two options of $(\mathcal{L}, R) = (0.1 \text{ fb}^{-1}/\text{yr}, 0.003\%)$ and $(1 \text{ fb}^{-1}/\text{yr}, 0.1\%)$, we find that the former maximizes S/\sqrt{B} when $\Gamma_{\tilde{\nu}_\tau}$ is small. In this scenario, $\Gamma_{\tilde{\nu}_\tau}$ is unknown *a priori*, but since a very small $\Gamma_{\tilde{\nu}_\tau}$ is quite possible (see Fig. 1), we employ this option. With this choice, signal cross sections after cuts are given by the solid contours in Fig. 2. We see that the cross sections may be extremely large (> 1 nb) in some regions of the allowed parameter space.

In Fig. 2 we also give sneutrino resonance discovery contours for two extreme possibilities. In the most optimistic case, the sneutrino mass is exactly known and the total luminosity is applied at the sneutrino resonance peak. The corresponding “optimistic” 3σ discovery contours are given by dashed lines. (In calculating S/\sqrt{B} for the $b\bar{b}$ mode here and below, we

¹If, as expected, right-handed sleptons are lighter than sneutrinos, $\tilde{\nu} \rightarrow \nu l_R \tilde{l}_R$ will be kinematically allowed. However, such decays are competitive with \mathcal{R}_P decays only if (i) the \mathcal{R}_P decays have the very small widths found for \mathcal{R}_P couplings close to or below the discovery limit and (ii) \tilde{B} and \tilde{l}_R are very light such that the R_P -conserving decay is nearly maximal. We therefore neglect decays to \tilde{l}_R in this analysis.

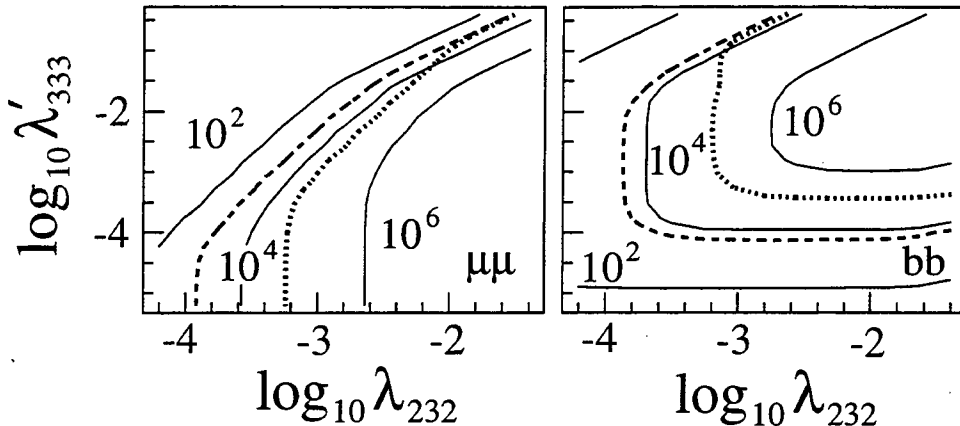

FIG. 2. Contours for (i) $\sigma(\mu^+\mu^- \rightarrow \tilde{\nu}_\tau \rightarrow \mu^+\mu^-)$ and (ii) $\sigma(\mu^+\mu^- \rightarrow \tilde{\nu}_\tau \rightarrow b\bar{b})$ (solid) in fb after cuts for the $m_{\tilde{\nu}_\tau} < m_{\chi^0}$ scenario, with $\sqrt{s} = m_{\tilde{\nu}_\tau} = 100$ GeV and $R = 0.003\%$. The dashed and dotted contours give the optimistic and pessimistic/scan 3σ discovery boundaries, respectively, for total integrated luminosity $L = 0.1$ fb $^{-1}$. (See discussion in text.)

include a 75% efficiency for tagging at least one b quark.) More realistically, the sneutrino mass will be known only approximately from other colliders with some uncertainty $\pm \frac{1}{2} \Delta m_{\tilde{\nu}_\tau}$; we assume $\Delta m_{\tilde{\nu}_\tau} = 100$ MeV using the fully reconstructable \mathcal{R}_P decays. To ensure significant overlap with the $\tilde{\nu}_\tau$ resonance, the luminosity should be distributed uniformly within this interval into $N = (\Delta m_{\tilde{\nu}_\tau} / \Delta\sqrt{s}) + 1$ scan points, where $\Delta\sqrt{s} = \max[2\sigma_{\sqrt{s}}, \Gamma_{\tilde{\nu}_\tau}]$. As noted above, $\Gamma_{\tilde{\nu}_\tau}$ is unknown beforehand in this scenario; to allow for the possibility of very narrow widths, we choose $\Delta\sqrt{s} = 2\sigma_{\sqrt{s}}$. We conservatively assume that all N points must be scanned before an observable signal becomes apparent.² If $\Gamma_{\tilde{\nu}_\tau} < \sigma_{\sqrt{s}}$, the worst possible case is when $m_{\tilde{\nu}_\tau}$ lies midway between two scan points. For discovery, we demand a 3σ excess in the combined data of these two points. If the width is large, the most difficult possibility is that $m_{\tilde{\nu}_\tau}$ lies at one end of the mass interval, so luminosity is collected in only one half of the peak. We demand a 3σ excess in the combined data collected at scan points lying within $\Gamma_{\tilde{\nu}_\tau}/2$ of $m_{\tilde{\nu}_\tau}$. The resulting ‘‘pessimistic/scan’’ $\tilde{\nu}_\tau$ discovery boundaries are the dotted contours of Fig. 2. The actual discovery limit should lie between the dashed and dotted contours. We see that $\tilde{\nu}_\tau$ resonance observation is possible for \mathcal{R}_P couplings as low as $10^{-3} - 10^{-4}$.

We now consider a second scenario in which $m_{\tilde{\nu}_\tau} > m_{\chi^0}$. In addition to the \mathcal{R}_P decays of the previous scenario, decays $\tilde{\nu}_\tau \rightarrow \nu_\tau \chi^0$ are therefore allowed and typically dominate, with χ^0 then decaying to $\nu_\tau \mu \mu$ or $\nu_\mu \mu \tau$ through the λ_{232} coupling, or $\nu_\tau b \bar{b}$ through the λ'_{333} coupling. We assume that no other $\tilde{\nu}_\tau$ decays are significant, and $\chi^0 \rightarrow l_R \bar{l}_R$ is closed. (Note that $\tilde{\nu}_\tau \rightarrow \nu_\tau l_R \bar{l}_R$, even if kinematically allowed, is again negligible, as it is typically highly suppressed relative to $\tilde{\nu}_\tau \rightarrow \nu_\tau \chi^0$.) The final signals are then $\mu^+\mu^- + \cancel{E}_T$, $\mu^\pm \tau^\mp + \cancel{E}_T$, and $b\bar{b} + \cancel{E}_T$. For this scenario, we consider masses $m_{\tilde{\nu}_\tau} = 150$ GeV and $m_{\chi^0} = 100$ GeV.

The signal cross sections for the $\nu \chi^0$ channel (without cuts) and the direct $\mathcal{R}_P b\bar{b}$ channel

²To maximize the probability of discovering a broad resonance early, the scan should be optimized by ordering the scan points such that, at any given time, the completed scan points are roughly uniformly distributed in the $\Delta m_{\tilde{\nu}_\tau}$ interval.

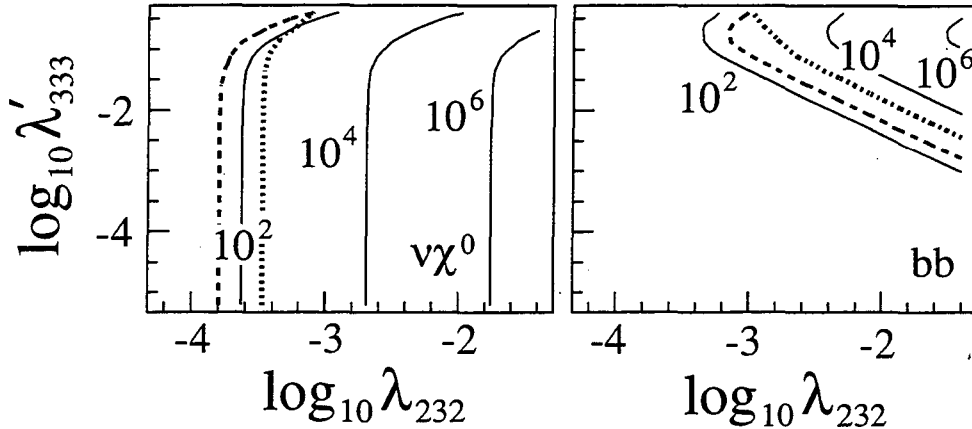

FIG. 3. Contours for (i) $\sigma(\mu^+\mu^- \rightarrow \tilde{\nu}_\tau \rightarrow \nu\chi^0)$ (no cuts) and (ii) $\sigma(\mu^+\mu^- \rightarrow \tilde{\nu}_\tau \rightarrow b\bar{b})$ (after cuts) in fb assuming $m_{\tilde{\nu}_\tau} = 150$ GeV, $m_{\chi^0} = 100$ GeV, and $\chi^0 = \tilde{B}$. The optimistic (dashed) and pessimistic/scan (dotted) discovery contours assume $L = 1$ fb $^{-1}$ and $R = 0.1\%$. (See text.)

(after cuts as in Fig. 2) are plotted in Fig. 3. (The cross section for the direct $\mathcal{R}_P \mu^+\mu^-$ channel is negligible unless λ_{232} is close to its current upper bound.) The leading backgrounds to the $\nu\chi^0$ channels are from $WW^{(*)}$ and $ZZ^{(*)}$. To reduce these, we require $\cancel{E}_T > 25$ GeV, that the visible final state fermions have $p_T > 25$ GeV and $60^\circ < \theta < 120^\circ$ for the lepton modes ($40^\circ < \theta < 140^\circ$ for the $b\bar{b} \cancel{E}_T$ mode), and that the invariant mass of the two visible fermions be > 50 GeV. With these cuts, the total combined background in the $\nu\chi^0$ channels is ~ 1 fb.

In Fig. 3, we also give 3σ discovery contours for both optimistic and pessimistic/scan cases as before. In the case of the $\nu\chi^0$ mode, we sum over all final channels and employ Poisson statistics. The kinematic distributions for the \cancel{E}_T modes depend on the masses of the superpartners entering virtually in the χ^0 decay. As an example, we have taken all sleptons degenerate with $\tilde{\nu}_\tau$ and $m_{\tilde{b}_{L,R}} = 200$ GeV. With these masses, the overall signal efficiency is 10% for both the $\mu^+\mu^- + \cancel{E}_T$ and $b\bar{b} + \cancel{E}_T$ channels (where, in the latter case, the b -tagging efficiency has been included as before); we assume a similar efficiency for the $\mu^\pm\tau^\mp + \cancel{E}_T$ channel.

The scan requires discussion. In this scenario, the dominant decay $\tilde{\nu}_\tau \rightarrow \nu_\tau\chi^0$ results in missing energy, so direct reconstruction of $m_{\tilde{\nu}_\tau}$ is impossible; the $\tilde{\nu}_\tau$ mass measurement at other colliders must then rely on kinematic endpoints, yielding typically $\Delta m_{\tilde{\nu}_\tau} \sim 2$ GeV. (More accurate mass measurements are possible if $\mathcal{R}_P b\bar{b}$ decays are also observed, but we will not assume this here.) However, in contrast to the previous scenario, $\Gamma_{\tilde{\nu}_\tau}$ is large and can be computed based on measurements of the χ^0 mass and composition [and $r_b \equiv B(\tilde{\nu}_\tau \rightarrow b\bar{b})/B(\tilde{\nu}_\tau \rightarrow \nu_\tau\chi^0)$ if significant] at other colliders. For our choice of parameters, $\Gamma_{\tilde{\nu}_\tau} = 0.36$ GeV $(1 + r_b)$, so we scan with $\Delta\sqrt{s} = \Gamma_{\tilde{\nu}_\tau}$ and $R = 0.1\%$ (which is adequate and allows maximal \mathcal{L}).

From Fig. 3, we see that the nearly background-free $\nu\chi^0$ mode makes possible a dramatic improvement in discovery reach compared to the $m_{\tilde{\nu}_\tau} < m_{\chi^0}$ scenario. The $\tilde{\nu}_\tau$ resonance may be discovered for $\lambda_{232} \gtrsim 10^{-4}$, irrespective of the value of λ'_{333} . Note that the discovery region in the direct $\mathcal{R}_P b\bar{b}$ channel is partially excluded by current bounds on $\lambda_{232}\lambda'_{333}$.

Once we have found the sneutrino resonance via the scan described, the crucial goal will

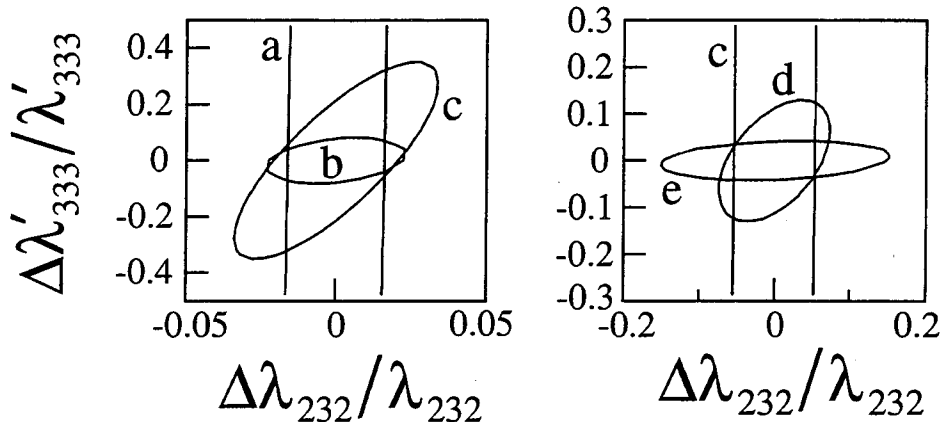

FIG. 4. $\chi^2 = 1$ contours in the $(\Delta\lambda_{232}/\lambda_{232}, \Delta\lambda'_{333}/\lambda'_{333})$ plane for (i) the $m_{\tilde{\nu}_\tau} = 100 \text{ GeV} < m_{\chi^0}$ scenario, assuming $L = 0.3 \text{ fb}^{-1}$, $R = 0.003\%$ and (ii) the $m_{\tilde{\nu}_\tau} = 150 \text{ GeV} > m_{\chi^0} = 100 \text{ GeV}$ scenario, assuming $L = 3 \text{ fb}^{-1}$, $R = 0.1\%$. Contours are for $\lambda_{232} = 5 \times 10^{-4}$ and $\lambda'_{333} =$: (a) 10^{-5} ; (b) 5×10^{-4} ; (c) 10^{-2} ; (d) 10^{-1} ; (e) 0.3.

be to precisely measure the relevant \mathcal{R}_P couplings. In the $m_{\tilde{\nu}_\tau} < m_{\chi^0}$ scenario, the discovery scan gives a precise determination of $m_{\tilde{\nu}_\tau}$ (and, if $\Gamma_{\tilde{\nu}_\tau} > 2\sigma_{\sqrt{s}}$, a rough determination of $\Gamma_{\tilde{\nu}_\tau}$). We then envision accumulating $L = 0.1 \text{ fb}^{-1}$ ($R = 0.003\%$) at each of the three points $\sqrt{s} = m_{\tilde{\nu}_\tau}, m_{\tilde{\nu}_\tau} \pm \Delta\sqrt{s}/2$, where $\Delta\sqrt{s} = \max[2\sigma_{\sqrt{s}}, \Gamma_{\tilde{\nu}_\tau}]$. The off-resonance points ensure good sensitivity to $\Gamma_{\tilde{\nu}_\tau}$. This is especially crucial when $\Gamma_{\tilde{\nu}_\tau} > \sigma_{\sqrt{s}}$, as in this case a single measurement of $\sigma_{\tilde{\nu}_\tau}$ at $\sqrt{s} = m_{\tilde{\nu}_\tau}$ determines $B(\tilde{\nu}_\tau \rightarrow \mu^+\mu^-)$ but not $\Gamma(\tilde{\nu}_\tau \rightarrow \mu^+\mu^-)$; see Eq. (5). In the $m_{\tilde{\nu}_\tau} > m_{\chi^0}$ scenario, we noted that $\Gamma_{\tilde{\nu}_\tau}$ can be computed with good precision from observations at other colliders; we assume a $\pm 5\%$ error for $\Gamma_{\tilde{\nu}_\tau}$. We would then run only at $\sqrt{s} \simeq m_{\tilde{\nu}_\tau}$ and accumulate $L = 3 \text{ fb}^{-1}$ ($R = 0.1\%$). In Fig. 4, the resulting $\chi^2 = 1$ error contours are plotted for each of the two scenarios. We find 1σ errors of $\Delta\lambda_{232}/\lambda_{232} \sim 2 - 15\%$ for the representative value of $\lambda_{232} = 5 \times 10^{-4}$, which is not very far inside the discovery regions; $\Delta\lambda'_{333}/\lambda'_{333} \sim 10 - 30\%$ is achieved if λ'_{333} is not too small. For small λ'_{333} in the $\tilde{\nu}_\tau \rightarrow \nu_\tau \chi^0$ scenario, $\Delta\lambda_{232}/\lambda_{232} \sim 3, 6, 10, 38, 110\%$ for $\lambda_{232} = 10^{-3}, 5 \times 10^{-4}, 3 \times 10^{-4}, 10^{-4}, 5 \times 10^{-5}$, respectively. Note that for small \mathcal{R}_P couplings, absolute measurements through other processes and at other colliders are extremely difficult, as they typically require that \mathcal{R}_P effects be competitive with a calculable R_P -conserving process. For example, \mathcal{R}_P neutralino branching ratios constrain only ratios of \mathcal{R}_P couplings.

As a final remark, we note that \mathcal{R}_P interactions can split the complex scalar $\tilde{\nu}_\tau$ into a real CP-even and a real CP-odd mass eigenstate. This splitting is generated both at tree-level (from sneutrino-Higgs mixing) and radiatively, and both contributions depend on many SUSY parameters. However, such \mathcal{R}_P terms also generate neutrino masses, and it is generally true that the sneutrino splittings generated are $\mathcal{O}(m_\nu)$ [12]. Given the current bound $\nu_\tau < 18.2 \text{ MeV}$ [13], we see that τ sneutrino splittings may be as large as $\mathcal{O}(10 \text{ MeV})$. A muon collider with $R = 0.003\%$ would be unique in its ability to resolve splittings of the resonance peak at the MeV level or better. The discovery of a non-zero ν_τ mass would be a significant motivation for exploring possible sneutrino splittings to high precision.

In summary, we have demonstrated that a muon collider is an excellent tool for discovering sneutrino resonances and measuring their R -parity violating couplings. In addition, such

a collider is unique in its ability to resolve the splitting between the CP-even and CP-odd sneutrino components when this splitting is as small as expected given the current bounds on neutrino masses. Further details will appear in a subsequent paper [5].

ACKNOWLEDGMENTS

The authors acknowledge important discussions with R. Hempfling and, especially, V. Barger. The authors thank the Aspen Center for Physics for hospitality, and J.L.F. is grateful to the high energy theory group at U. C. Davis for hospitality during the completion of this work. This work was supported in part by the Director, Office of Energy Research, Office of High Energy and Nuclear Physics, Division of High Energy Physics of the DOE under Contracts DE-AC03-76SF00098 and DE-FG03-91ER40674, by the NSF under grant PHY-95-14797, and by the U.C. Davis Institute for High Energy Physics.

REFERENCES

- [1] S. Dimopoulos and L. J. Hall, Phys. Lett. B **207**, 210 (1988); S. Dimopoulos, R. Esmaeilzadeh, L. J. Hall, J.-P. Merlo, and G. D. Starkman, Phys. Rev. D **41**, 2099 (1990); H. Dreiner and S. Lola, in *Proceedings of the Workshop on e^+e^- Collisions at 500 GeV*, 1991.
- [2] V. Barger, G. F. Giudice, and T. Han, Phys. Rev. D **40**, 2987 (1989).
- [3] J. Erler, J. L. Feng, and N. Polonsky, Phys. Rev. Lett. **78**, 3063 (1997).
- [4] V. Barger, M. S. Berger, J. F. Gunion, and T. Han, Phys. Rev. Lett. **75**, 1462 (1995); Phys. Rept. **286**, 1 (1997).
- [5] J. L. Feng, J. F. Gunion, and T. Han, in preparation.
- [6] H. Dreiner, hep-ph/9707435.
- [7] R. M. Barnett *et al.*, Phys. Rev. D **54**, 1 (1996).
- [8] G. Bhattacharyya, J. Ellis, and K. Sridhar, Mod. Phys. Lett. A **10**, 1699 (1995).
- [9] K. Agashe and M. Graesser, Phys. Rev. D **54**, 4445 (1996).
- [10] J.-H. Jang, J. K. Kim, and J. S. Lee, Phys. Rev. D **55**, 7296 (1997).
- [11] CDF Collaboration, F. Abe *et al.*, Fermilab Conf-96/320-E.
- [12] See, *e.g.*, N. Polonsky, hep-ph/9708325; Y. Grossman, hep-ph/9710276; and references therein.
- [13] M. Girone, ALEPH Collaboration, talk #1003 presented at the International Europhysics Conference on High Energy Physics, 19–26 August 1997, Jerusalem, Israel.

**ERNEST ORLANDO LAWRENCE BERKELEY NATIONAL LABORATORY
ONE CYCLOTRON ROAD | BERKELEY, CALIFORNIA 94720**

Prepared for the U.S. Department of Energy under Contract No. DE-AC03-76SF00098