

UC Riverside

UC Riverside Previously Published Works

Title

A Modified Mole Cricket Lure and Description of *Scapteriscus borellii* (Orthoptera: Gryllotalpidae) Range Expansion and Calling Song in California

Permalink

<https://escholarship.org/uc/item/8q98w4zn>

Journal

Environmental Entomology, 43(1)

ISSN

0046-225X

Authors

Dillman, Adler R
Cronin, Christopher J
Tang, Joseph
[et al.](#)

Publication Date

2014-02-01

DOI

10.1603/en13152

Peer reviewed



Published in final edited form as:

Environ Entomol. 2014 February ; 43(1): 146–156. doi:10.1603/EN13152.

A Modified Mole Cricket Lure and Description of *Scapteriscus borellii* (Orthoptera: Gryllotalpidae) Range Expansion and Calling Song in California

Adler R. Dillman^{1,4}, Christopher J. Cronin¹, Joseph Tang^{2,5}, David A. Gray³, and Paul W. Sternberg¹

¹Howard Hughes Medical Institute, Division of Biology, California Institute of Technology, Pasadena, CA 91125, USA

²Arcadia High School, Arcadia, CA 91007, USA

³Department of Biology, California State University, Northridge, CA 91330, USA

Abstract

Invasive mole cricket species in the genus *Scapteriscus* have become significant agricultural pests and are continuing to expand their range in North America. Though largely subterranean, adults of some species such as *S. borellii* are capable of long dispersive flights and phonotaxis to male calling songs to find suitable habitats and mates. Mole crickets in the genus *Scapteriscus* are known to be attracted to and can be caught by audio lure traps that broadcast synthesized or recorded calling songs. We report improvements in the design and production of electronic controllers for the automation of semi-permanent mole cricket trap lures as well as highly portable audio trap collection designs. Using these improved audio lure traps we collected the first reported individuals of the pest mole cricket *S. borellii* in California. We describe several characteristic features of the calling song of the California population including that the pulse rate is a function of soil temperature, similar to Florida populations of *S. borellii*. Further, we show that other calling song characteristics (carrier frequency, intensity, and pulse rate) are significantly different between the populations.

Keywords

Scapteriscus borellii; mole cricket; cricket trap; calling song

Introduction

Crickets in the family Gryllotalpidae are commonly known as mole crickets, aptly named for their largely subterranean lifestyle and accompanying morphology (e.g. large dactyls for digging), giving them some similarities with moles (Fig. 1). Native mole cricket species in the U.S. are typically innocuous and some are rare, presumably due to the balance between population growth, food availability, predators, and disease, among other ecological factors

⁴Current address: Department of Microbiology and Immunology, Stanford University, Stanford, CA 94305, USA

⁵Current address: Department of Biology, Boston University, Boston, MA 02215, USA

(Frank, 2009; Vaughn et al., 1993). Invasive mole crickets have become significant agricultural pests and have been extensively studied in the southeastern United States (Walker and Nickle, 1981). They are known to cause damage to golf courses, lawns, pastures, and the rising turf grass industry (Liskey, 2000). A 1986 estimate suggested mole cricket damage and control in Alabama, Florida, Georgia, and South Carolina cost \$80 million combined, annually (Frank and Parkman, 1999). The invasive species in the U.S., *Scapteriscus abbreviatus*, *S. borellii* (previously known as *S. acletus*), and *S. vicinus*, are thought to have spread to North America via commercial sailing vessels from South America between 1895 and 1925 (Walker and Nickle, 1981). *S. borellii*, the southern mole cricket, is mostly subterranean though it has long winged adults that can fly. It is the most widespread of the invasive species in the U.S with a known distribution spanning from North Carolina to Arizona (Nickle and Frank, 1988; Walker, 1984) and has also been reported in northern Mexico (García, 2006). Because *S. borellii* had been detected in Yuma, Arizona, it was assumed that expansion to California was inevitable (Frank, 1994), but confirmation of this assumption has remained absent from peer-reviewed literature. A recent report from the California Department of Food and Agriculture suggested that *S. borellii* had expanded its distribution to Downey, CA (http://www.cdfa.ca.gov/plant/PPD/pest_sheets.html-orthoptera), while a recent agricultural brief (July, 2012) indicates invasive mole cricket presence in Imperial County, CA (http://ceimperial.ucanr.edu/news_359/Ag_Briefs/).

Aside from their status as pests, biological interest in mole crickets stems from the amplifier-like chambers the males construct to sing their calling song to attract mates and their phonotactic ability. *Scapteriscus* mole crickets were the first insects found to use phonotaxis for mate-finding where orientation actually occurred during flight (Ulagaraj and Walker, 1973). The songs of described *Scapteriscus* mole cricket species are remarkable in a number of ways: they sing in a continuous trill, they are unusually pure, the carrier frequency is constant, the level of higher harmonics is low, the calling song is exceptionally loud, at least for *S. borellii*, and they are sung from specially constructed horn-shaped burrows, which contribute to all of these qualities (Bennet-Clark, 1970; Bennet-Clark, 1987; Forrest, 1983; Forrest, 1991; Ulagaraj, 1976).

As significant agricultural pests, the potential use of synthetic or recorded mating calls to lure mole crickets into traps was immediately apparent and put to use. Several components are needed in constructing a sound lure and cricket trap: 1) a collection device to catch and hold the crickets, 2) a sound source that attracts the crickets, and 3) a controller, providing power and control of the sound electronics (Walker, 1996). Sound traps for collecting *Scapteriscus* mole crickets have been extensively used and altered since they were originally implemented in 1973. The first traps used were relatively simple, composed of a tape recorder, an amplifier, and a speaker, suspended over a large funnel attached to a jar (Ulagaraj and Walker, 1973). The tape recorders were used to broadcast field recorded songs or synthetic calling songs made and tape-recorded in the lab. Nearly a decade after these initial traps, improvements were made for both the collection device and the lure, which were called Oldacre traps (after their designer, William Oldacre (Walker, 1982)). The improvements allowed for limited automation and lead to less supervised, less cumbersome,

and more efficient cricket traps (Walker, 1982). Several years later, the mole cricket sound traps were further improved as the design of the lure was tailored for increased economy and versatility, increased automation, and made amenable to larger scale production through commercial contracting. These alterations led to the ‘artificial cricket’ or ‘Mans unit’ (named for the designer, Bernard Mans), which is still used as the lure for traps in recent studies (Frank and Walker, 2006; Thompson et al., 2007; Walker, 1990; Walker, 1996). Further improvements to the collection device, making use of large plastic wading pools, have made the sound traps more affordable, quicker and easier to assemble, temporary at each site (which is appreciated if not demanded by golf course superintendents), and able to maintain live specimens for seven days, thus requiring even less supervision (Thompson and Brandenburg, 2004).

We explored the possibility of reproducing the Mans-design artificial cricket and found the literature on the collection part of the device, particularly the recent improvement of plastic wading pools, to be clear and easy to follow (Thompson and Brandenburg, 2004). However, we found the complexity of the assembly language software, the seemingly incomplete written design, and the unavailability of newly produced models of the Mans-design artificial cricket discouraging. We determined to redesign the controller so that rather than being commercially ordered it could be constructed in lab with minimal to no engineering background. We wrote the underlying source code for the controller in an open-source language, allowing individual researchers to easily modify the operating conditions thus making this trap more accessible to the biological community.

Here we describe the design and construction of a new audio cricket trap, which we used to survey the Rio Hondo Golf course in Downey, CA. We report the presence of *S. borellii* in southern California, confirming previous assumptions that this range expansion would occur (Frank, 1994), and we describe the CA population of *S. borellii* and analyze elements of the male calling song.

MATERIAL AND METHODS

Construction of a semi-permanent trap

Three major components are involved in the construction of an autonomous mole cricket audio trap (Walker, 1982): 1) a catching device, 2) sound source, and 3) controller.

1) Catching device—We constructed a wading pool catching device, the latest improvement to mole cricket audio lure traps, as previously described (Thompson and Brandenburg, 2004) (Fig. 2). Briefly, two large plastic wading pools (~5 ft or 1.5 m in diameter) are used, one suspended over the other by four evenly distributed 2-inch×6-inch nominal wooden spacers (actual dimensions 1.5×5.5 inches or 38×140 mm), which prevent sagging and distortion of the top pool over time. The pools and spacers were secured with a bolt, washer, and nut for each of the four spacers. The top pool had 12 evenly spaced 13.5 cm diameter holes cut through its bottom, allowing crickets to fall into the bottom pool which was filled with moist sand. Small drainage holes and slits were drilled/cut into the bottom of the bottom wading pool to allow drainage. Weatherproof speakers were mounted on a 6-foot (183 cm) long, 1-inch×4-inch nominal wooden fence board (actual dimensions

0.625 inch×3.375 inch, or 16 mm×86 mm) along with a weatherproofed photoresistor for automated operation of the controller and audio playback. The fence board was then mounted across the top of the upper wading pool, being secured to two diametrically opposed spacers by the bolts used to secure the spacers to the pools (Fig. 2).

2) Sound source—We explored several options for amplifying and broadcasting the cricket mating call, but for simplicity we elected to use a commercially-built amplifier and speaker rig intended for use outdoors on a motorcycle or snowmobile (Model PLMCA20, Pyle Audio, Brooklyn, NY). The selected sound system featured an auxiliary input jack capable of accepting output from an external audio source. The accompanying speakers were already waterproof, eliminating the need for further weather protection such as a plastic bag, which could distort or otherwise affect the broadcasted signal (Fig. 2 and 3A). A field recording of a male calling song was looped and used for the trap lure (supplementary material).

3) Controller—The electronic system that controlled the timing and function of our cricket lure, the controller, was constructed to prioritize certain functional features such that the trap would begin playing the recorded mating call at dusk, play the mating call at the predetermined optimal sound pressure level of 106 dB (measured at 15 cm from the audio source (Walker and Forrest, 1989)), stop playing after 120 minutes, reset itself to repeat this cycle on the following day, and be capable of performing these functions unsupervised for at least a week at a time.

We selected an Arduino Uno microcontroller board to run the various functions of our audio lure (<http://arduino.cc/en/>). In addition to ease of use, the open-source nature of Arduino's hardware and software made it ideal for our purposes of developing a system easily accessible to the biology research community. We attached a Wave Shield (Model v1.1, Adafruit Industries, New York ; <http://www.ladyada.net/make/waveshield/>) to the Arduino microcontroller to handle playback of audio files stored on a secure digital (SD) card (<http://www.adafruit.com/products/94>) (Fig. 3A). An external photoresistor and indicator LED (both waterproofed) were interfaced to the controller through separate circuit boards (Fig. 3A). There was no electrical outlet at our sampling site, which required our design to be battery powered. A 35 amp-hour (Ah), 12 V battery (Model PS12350 NB, Power-Sonic, San Diego, CA) was used to power the controller and sound source for the semi-permanent pool trap. This battery was recharged periodically using a floating charger (Model FC-12250, 12 VDC 1.5A output, PHC Enterprise, Torrance, CA), but to maximize available battery power we built a simple relay-based switching circuit that the Arduino activated to power the amplifier only when playing audio. Non-weatherproofed components like the Arduino, Wave Shield and battery were housed in a covered plastic container set next to the wading pools (Fig. 3A) for protection from the elements while weatherproofed elements like the speakers, LED and photoresistor were left exposed at the trap. All electronic components for the controller assembly were purchased from local retailers and from online merchants (Orvac Electronics, Pasadena, CA; Fry's Electronics, Los Angeles, CA; and Amazon.com).

We programmed the controller through the Arduino Integrated Development Environment using the open source Arduino programming language, a high-level language similar to the

C programming language (<http://arduino.cc/en/main/software>). In programming the controller we wrote the code with the goal that all functional features could be easily adjusted to suit different needs (supplementary material).

A schematic drawing of the electronics is shown in Fig. 3B. For additional methods, controller details and the full programming code see supplemental material.

Construction of highly portable traps

The designs of the portable traps were much simpler than that of the semi-permanent trap with ease of portability by a solo researcher of particular importance. Since the portable traps were intended to be delivered, set up, run, broken down, and returned to in-laboratory storage each trapping evening, an autonomous controller was no longer necessary. We developed five portable trap designs that we refer to as the “Benjamin,” “Cross,” “Sheet,” “Table,” and “Umbrella” designs (Fig. 4).

1) Catching device—These designs vary from a sophisticated inverted umbrella-like design requiring well-calculated measurements during fabrication to a bed sheet with a hole cut out, stapled to a plastic container. Full details of the designs are available in the supplemental material.

2) Sound source—Two different sound sources were used interchangeably to operate the five trap designs, both using the same two-hour audio recording as the semi-permanent trap. The first design played the two-hour audio recording from a small and affordable MP3 player (Model SMP2012 2GB, Sylvania, Danvers, MA) connected to an amplifier and speaker system identical to that used for the pool trap (Model PLMCA20, Pyle Audio, Brooklyn, NY) but that used only one of the two speakers. The other audio design used an amplifier with a built-in SD card reader (Model PLMCA25U, Pyle Audio, Brooklyn, NY) to play the audio recording stored on an SD card through a single speaker from a Pyle PLMCA20 system. These audio systems were each powered by a 5 Ah, 12 V rechargeable, sealed lead acid battery (Model PS-1250 F1, Power-Sonic, San Diego, CA), which we regularly recharged using a floating charger (Model FC-12250, 12 VDC 1.5A output, PHC Enterprise, Torrance, CA). These portable traps were set up and the lures manually turned on for 1.5-2 hours, to coincide with live mole cricket calling songs at the Rio Hondo Golf Course. Lures were manually shut off after the resident mole crickets stopped calling for the night. Any crickets found in or around the traps were then counted and collected and the traps were taken down and stored until the next trapping evening.

Traps were used at four different locations (Fig. 5), chosen due to high visible cricket activity and the advice of the golf course superintendent who had been dealing with mole cricket damage since 2006. Portable traps were set up and used on seven different nights from June to July of 2011. Each of the four portable trap locations was used at least four times and as many as seven (Fig. 6; Table 1 and S1).

Mole cricket song recording and analysis

Southern mole crickets, *Scapteriscus borellii*, were collected from the Rio Hondo Golf Club, Downey, CA, from April to July, 2011. Collecting was done using a semi-permanent and highly portable audio lure traps. The semi-permanent trap was programmed to play an audio lure for 2 hours nightly from May through July, 2011. It was set up inside the golf course nursery to prevent possible theft/human disturbance of the trap and because the nursery was one of the highest activity areas noticed by the superintendent. We checked the trap periodically (semi-permanent trap was checked every 4-12 days (Table 2)) to see how many crickets it had trapped, to recharge the battery, and to verify that the automation was working properly. Captured crickets were used in host-range and –preference assays using entomopathogenic nematodes. These experiments were published previously (Dillman et al., 2012).

We audio recorded numerous individual male mole cricket calling and courtship songs in the field at the Rio Hondo Golf Course. Songs were recorded using the onboard microphone in an Apple MacBook Pro (Model MC374*/A, Apple, Cupertino, CA) with the Audacity software package (<http://audacity.sourceforge.net/>) with Audacity's default recording settings (Stereo, 44100Hz, 32-bit float). Individual males were recorded for 1.5-2 minutes each. Recordings were taken by positioning the microphone approximately 15 cm from the opening of a singing male's burrow. Sound pressure measurements of calling songs were taken at 15 centimeters from the burrow opening using a sound-level meter (Model 33-2055, RadioShack, Fort Worth, TX) with the meter's "C-weighting" and "Fast response time" settings. Calling songs were analyzed using the software package Raven Pro 1.4 (Cornell Laboratory of Ornithology, Ithaca, NY, U.S.A.). We measured a defined set of temporal parameters, which can be divided into the following trill elements for the calling songs: trill length (TL), duration of the break in the trill (BD), the length of the pulses in the trill (TPL), the interval between the pulses in the trill (TPI), and the number of pulses in the trill element (P/T) (Fig. 7) (Simmons et al., 2010).

Statistical analysis

S. borellii calling song metrics (intensity, carrier frequency, and pulse rate) were compared between the Florida and California populations using an unpaired t test with Welch's correction using the calculated mean, standard deviation and sample size rather than using raw data because the raw data were not available for the FL population (Ulagaraj, 1976). Regression analysis was performed on the raw calling song data from the CA population. All analyses were carried out using GraphPad Prism version 6.0a for Mac OS X (GraphPad Software, San Diego CA USA, <http://www.graphpad.com>).

RESULTS

Pool trap

The controller and light sensor assembly proved capable of appropriately responding to dusk; specifically, it turned the audio lure on and off as desired for the entire course of our trapping experiment (53 days), being checked only periodically for cricket collection and battery charging (Table S2). Electrical current draw was a serious concern, especially since

the trap needed to function autonomously for at least seven days to minimize supervision. The controller drew 61 milliamps (mA) at 12.5 VDC, even when the lure was not broadcasting and this increased to 130 mA when playing audio at full volume (full Wave Shield volume). The amplifier broadcasting the Wave Shield's output through speakers at the previously determined optimal sound pressure level of 106 dB (measured 15 cm in front of the speaker (Walker and Forrest, 1989)) drew approximately 450 mA. The 35 Ah battery proved capable of maintaining the full function of the trap and lure for as many as 12 consecutive days (Table 2), and potentially longer, though this may not be a good strategy for collecting *S. borellii* for any downstream applications since they are cannibalistic (Thompson and Brandenburg, 2004; Thompson et al., 2007). The pool trap lured and trapped 16 female crickets during its 53 days of operation (Table 1 and S1).

Portable traps

The five different portable traps used each caught between 6 and 15 mole crickets in 4-5 nights of use, for a total of 48 female and 13 male *S. borellii* adult crickets (Table 1). All of these designs caught at least 6 crickets in the four to five nights of sampling that each trap was used (Fig. 6; Table 1 and S1). Some sites were more productive than others, with site 3 being the most productive, yielding 39 crickets, 64% of our portable trap total, caught over seven nights of sampling with different traps (Fig. 6; Table 1 and S1). Site 5 was the least productive only leading to a single cricket caught in four nights of trapping. Some nights were better for catching crickets than others and this could explain the difference in site productivity observed. More sampling days using the portable traps would be required to make statistically meaningful conclusions about the effects of trap type, location, and sampling day (Fig. 6). Despite previous reports of other crickets sometimes being caught in these audio lure traps (Ulagaraj and Walker, 1973), we caught only *S. borellii* crickets in these traps. Many of the crickets we caught were found near (within 10 feet) the trap rather than in it (37 in traps and 24 near) (Table S1). 3 of the 13 males caught were actually inside a trap, with the rest being caught near traps.

S. borellii song analysis

As noted in Ulagaraj (1976), the *S. borellii* calling song is a long bell-shaped trill with three sections: 1) a few seconds of high-amplitude pulses, 2) followed by a period of pulses with decreasing amplitude, and 3) continuing with pulses at the decreased amplitude for up to several minutes until the end of the trill (Fig. 7). Table 2 provides the calling song elements we analyzed. We compared calling song elements from the Downey, CA, *S. borellii* population with those reported for an *S. borellii* population near Gainesville, FL (Ulagaraj, 1976). The measurements of intensity, carrier frequency, and pulse rate of CA *S. borellii* were significantly different from those elements of FL *S. borellii* using a corrected unpaired t test; indicating that the California population sampled in this study called at slightly higher intensity, higher carrier frequency, and slower pulse rate (Table 2). We also found, using regression analysis, that the pulse rate of the calling song is a function of soil temperature (Fig. 8), which agrees with the earlier findings of Ulagaraj (Ulagaraj, 1976). The slope of our regression (1.465 ± 0.233 p/s per degree) did not differ significantly from the work of Ulagaraj (1.4 p/s per degree).

We were able to record several courtship songs for the CA *S. borellii* population and found the series of short, rhythmic chirps to be just as previously described for the FL population (Ulagaraj, 1976). However, we did observe a different and previously unreported alternative state within the courtship call, characterized by a distinct change in the number of pulses. The previously described courtship song shows chirps being progressive and abruptly cutting off. This second state within the courtship song changes, with the chirps following a different pattern of ascending and descending in relative amplitude rather than ending abruptly at or near peak amplitude as happens during the rhythmic chirping state of the courtship song (Fig. 9).

DISCUSSION

We report the first known establishment of *S. borellii* in California, confirming previous fears that this species would continue to spread West (Frank, 1994; Nickle and Frank, 1988). In order to study these crickets, we have redesigned and updated the lure and controller for an acoustic mole cricket trap. The previous design was developed in 1989 and available only through commercial production (Thompson and Brandenburg, 2004; Walker, 1990). Our improved design uses easily available components, open access software, and can be built 'in-house' by tinkering biologists, no engineering background required. We have shown that this design can operate unsupervised for at least 12 days and is easily modifiable to suit individual needs. In addition to the improvements of the semi-permanent trap design, we have designed and used highly portable traps of varying complexity from a sophisticated inverted umbrella design to a simple bed sheet stapled to a plastic box, all of which we have successfully used in the field to catch mole crickets (Table 1 and S1).

At present the Downey *S. borellii* population seems to be quite small and is subject to rigorous control treatments by the landscaping crew and superintendent of the Rio Hondo Golf Club. A recent agricultural brief suggests that *Scapteriscus* mole crickets are also in Imperial County (http://ceimperial.ucanr.edu/news_359/Ag_Briefs/), though this finding has not yet been reported in peer-reviewed literature. Previous researchers assumed that the presence of *S. borellii* in Yuma, AZ ensured their eventual spread to California (Frank, 1994), which we now report to be true. Nickle and Frank (Nickle and Frank, 1988) suggested that Mexico could soon inherit the pest insect *S. borellii* from the U.S., which also seems to have happened (García, 2006). Single *S. borellii* individuals are known to disperse by flying and have been recaptured more than 700 meters from release experiments (Ulagaraj, 1975). The factors that cause these dispersive flights remain unknown (e.g. overcrowding, availability of food, availability of mates, etc.) The agricultural impact of these mole crickets in California is minuscule at present, but their potential to expand into more areas of California and Mexico is foreboding. The seemingly limited distribution of *S. borellii* in California suggests that an aggressive control program could prevent population growth or further spread (Frank, 1994; Frank, 2009; Frank and Walker, 2006; Nickle and Frank, 1988). However, the presence of *S. borellii* in Yuma for at least 25 years and their more recently observed expansions into certain parts of California and Mexico, indicate that this pest will likely continue to spread if unchecked. The expansion of *S. borellii* in the West also highlights the possibility of other flying mole cricket pests, such as *S. vicinus* to expand their distribution further West as well.

To better characterize the Downey population of *S. borellii*, we have reported here several elements of the male calling song (Table 2). We have shown that, like FL *S. borellii* populations, pulse rate of the calling song is a function of soil temperature (Fig. 8). However, all other calling song elements compared (intensity, carrier frequency, and pulse rate) were significantly different between FL and CA populations (Table 2). It is not currently clear to us the significance of these calling song differences. Perhaps these differences reflect the different climates of southern Florida and southern California, or they could be suggestive of evolutionary changes between the populations. Assuming the Downey population is derived from expanding progeny of one of the known founding events in the West (Walker, 1984), the FL population and the Downey population of *S. borellii* have been separated for ~80-110 years. The differences in calling song that we have identified compare recordings made decades apart with different (but broadly comparable) recording technologies and the difference we have identified highlight the need for further investigations of calling song variation between populations.

Supplementary Material

Refer to Web version on PubMed Central for supplementary material.

ACKNOWLEDGEMENTS

We thank John Rodriguez and the Rio Hondo Golf Club for the cooperation and help in our sampling efforts, John DeModena for fruitful discussions, advice, and critical reading of the manuscript, Benjamin Cronin for trap design discussions and recommendations, and J. Howard Frank for many suggestions, discussion, critical reading of the manuscript, and sharing his mole cricket expertise. We thank Brian Anderson, Michael E. Castillo, and Esther Thompson for help with mole cricket collection. We also appreciate the time and suggestions of anonymous reviewers. This work was supported by a National Institutes of Health (NIH) United States Public Health Service Training Grant (5T32GM07616) to A.R.D. and by the Howard Hughes Medical Institute (with which P.W.S. is an investigator).

REFERENCES

- Bennet-Clark HC. The mechanism and efficiency of sound production in mole crickets. *Journal of Experimental Biology*. 1970; 2:619–652.
- Bennet-Clark HC. The tuned singing burrow of mole crickets. *Journal of Experimental Biology*. 1987; 128:383–409.
- Dillman AR, Guillermin ML, Lee JH, Kim B, Sternberg PW, Hallem EA. Olfaction shapes host-parasite interactions in parasitic nematodes. *Proc Natl Acad Sci U S A*. 2012; 109:E2324–E2333. [PubMed: 22851767]
- Forrest, TG. Calling songs and mate choice in mole crickets. In: Gwynne, DT.; Morris, GK., editors. *Orthopteran mating systems: sexual competition in a diverse group of insects*. Boulder, Colorado: Westview Press; 1983. p. 185-204.
- Forrest TG. Power output and efficiency of sound production by crickets. *Behavioral Ecology*. 1991; 2:327–338.
- Frank, JH. Biological control of pest mole crickets. In: Rosen, D.; Bennett, FD.; Capinera, JL., editors. *Pest Management in the subtropics. Biological Control - A Florida Perspective*. Andover, England: Intercept; 1994. p. 343-352.
- Frank, JH. *Steinernema scapterisci* as a biological control agent of *Scapteriscus* mole crickets. In: Hajek, AE., editor. *Use of microbes for control and eradication of invasive arthropods*. Vol. 6. The Netherlands: Springer; 2009. p. 115-131.
- Frank JH, Parkman JP. Integrated pest management of pest mole crickets with emphasis on the southeastern USA. *Integrated pest management reviews*. 1999; 4:39–52.

- Frank JH, Walker TJ. Permanent control of pest mole crickets (Orthoptera: Gryllotalpidae: *Scapteriscus*) in Florida. *American Entomologist*. 2006; 52:138–144.
- García ER. An annotated checklist of some orthopteroid insects of Mapimi biosphere reserve (Chihuahuan desert), Mexico. *Acta Zoológica Mexicana*. 2006; 22:131–149.
- Liskey E. Turf's most (un)wanted pests. *Grounds Maintenance*. 2000; 35:18.
- Nickle DA, Frank W. Pest mole crickets, *Scapteriscus acletus* (Orthoptera, Gryllotalpidae), reported established in Arizona. *Florida Entomologist*. 1988; 71:90–91.
- Simmons LW, Tinghitella RM, Zuk M. Quantitative genetic variation in courtship song and its covariation with immune function and sperm quality in the field cricket *Teleogryllus oceanicus*. *Behavioral Ecology*. 2010; 21:1330–1336.
- Thompson SR, Brandenburg RL. A modified pool design for collecting adult mole crickets (Orthoptera: Gryllotalpidae). *Florida Entomologist*. 2004; 87:582–583.
- Thompson SR, Brandenburg RL, Robertson GT. Entomopathogenic fungi detection and avoidance by mole crickets (Orthoptera: Gryllotalpidae). *Environmental Entomology*. 2007; 36:165–172. [PubMed: 17349130]
- Ulagaraj SM. Mole crickets - Ecology, behavior, and dispersal flight (Orthoptera-Gryllotalpidae-*Scapteriscus*). *Environmental Entomology*. 1975; 4:265–273.
- Ulagaraj SM. Sound production in mole crickets (Orthoptera-Gryllotalpidae-*Scapteriscus*). *Annals of the Entomological Society of America*. 1976; 69:299–306.
- Ulagaraj SM, Walker TJ. Phonotaxis of crickets in flight: Attraction of male and female crickets to male calling songs. *Science*. 1973; 182:1278–1279. [PubMed: 17811322]
- Vaughn CC, Glenn SM, Butler IH. Characterization of prairie mole cricket chorusing sites in Oklahoma. *American Midland Naturalist*. 1993; 130:364–371.
- Walker TJ. Sound traps for sampling mole cricket flights (Orthoptera: Gryllotalpidae: *Scapteriscus*). *Florida Entomologist*. 1982; 65:105–110.
- Walker TJ. Biology of pest mole crickets: systematics and life cycles. University of Florida Agriculture Station Bulletin. 1984; 846:3–10.
- Walker, TJ. Annual report on mole cricket research 89–90. University of Florida; 1990. p. 6-17.
- Walker, TJ. Acoustic methods of monitoring insect pests and their natural enemies. In: Rosen, D.; Capinera, JL.; Bennett, FD., editors. *Pest Management in the Subtropics: Integrated Pest Management - A Florida Perspective*. Andover: Intercept; 1996. p. 245-257.
- Walker TJ, Forrest TG. Mole cricket phonotaxis: Effects of intensity of synthetic calling song (Orthoptera: Gryllotalpidae: *Scapteriscus acletus*). *Florida Entomologist*. 1989; 72:655–659.
- Walker TJ, Nickle DA. Introduction and spread of pest mole crickets - *Scapteriscus vicinus* and *Scapteriscus acletus* reexamined. *Annals of the Entomological Society of America*. 1981; 74:158–163.



left foreleg

Fig. 1. Pictures of identifying features of *Scapteriscus borellii* from Downey, CA.



Fig. 2.
The design of the semi-permanent wading pool trap.

A Controller

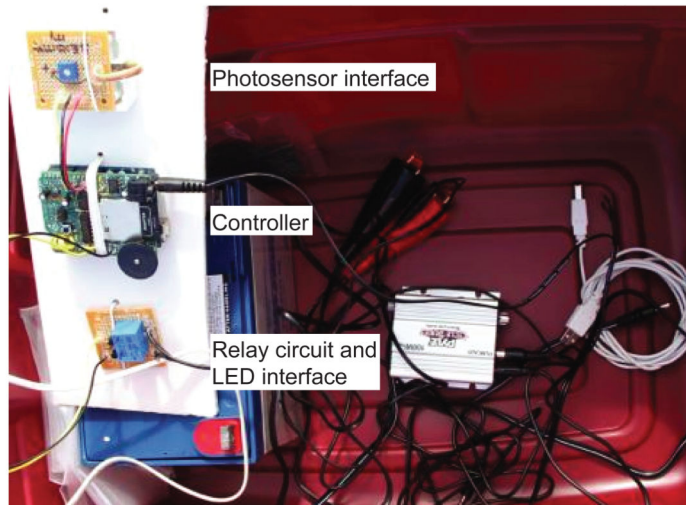

B Controller circuit schematic

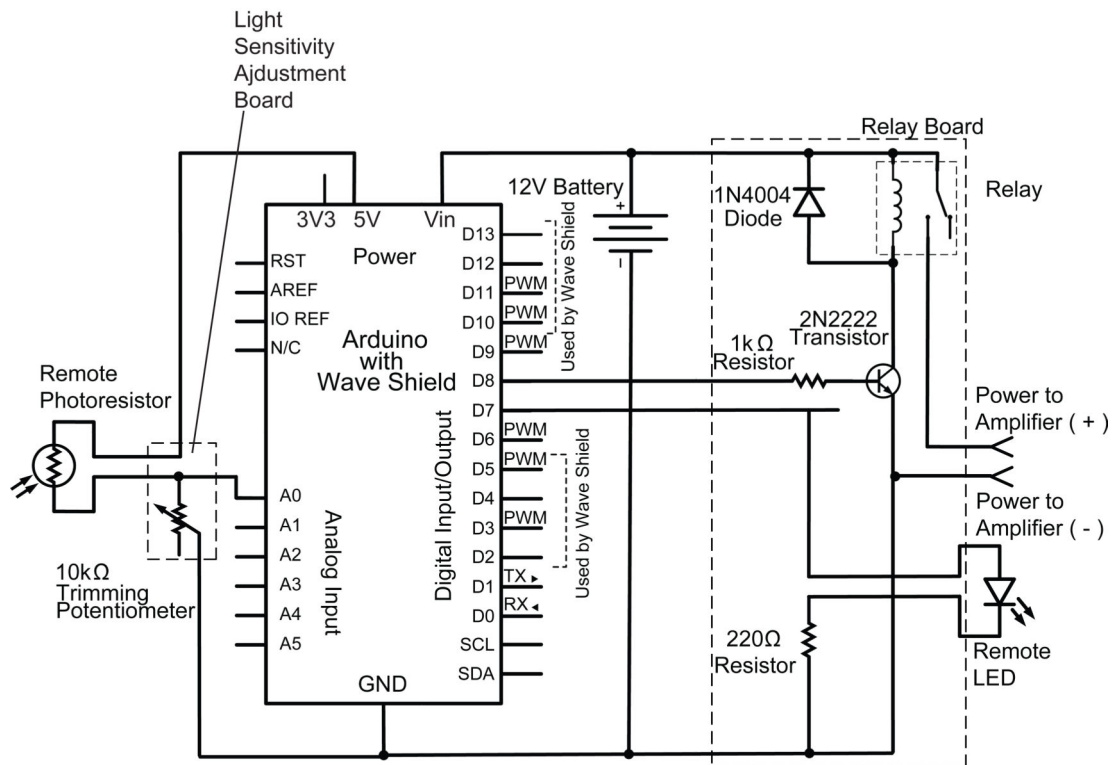

Fig. 3.

A) The controller and electronics of the wading pool trap, housed in a plastic, weatherproof container. B) Controller circuit schematic depicting Arduino microcontroller with Wave Shield, separate Light Sensitivity Adjustment and Relay boards, and remote photoresistor, indicator LED and audio amplifier connection.

A The “Benjamin” portable trap



B The “Cross” portable trap



C The “Sheet” portable trap



D The “Table” portable trap



E The “Umbrella” portable trap



F MP3 portable controller



G SD card portable controller



Fig. 4. The portable trap designs. A) “Benjamin.” B) “Cross.” C) “Sheet.” D) “Table.” E) “Umbrella.” F) MP3 portable controller. G) SD card portable controller.



Fig. 5.
Sampling locations used at the Rio Hondo Golf Club in Downey, CA.

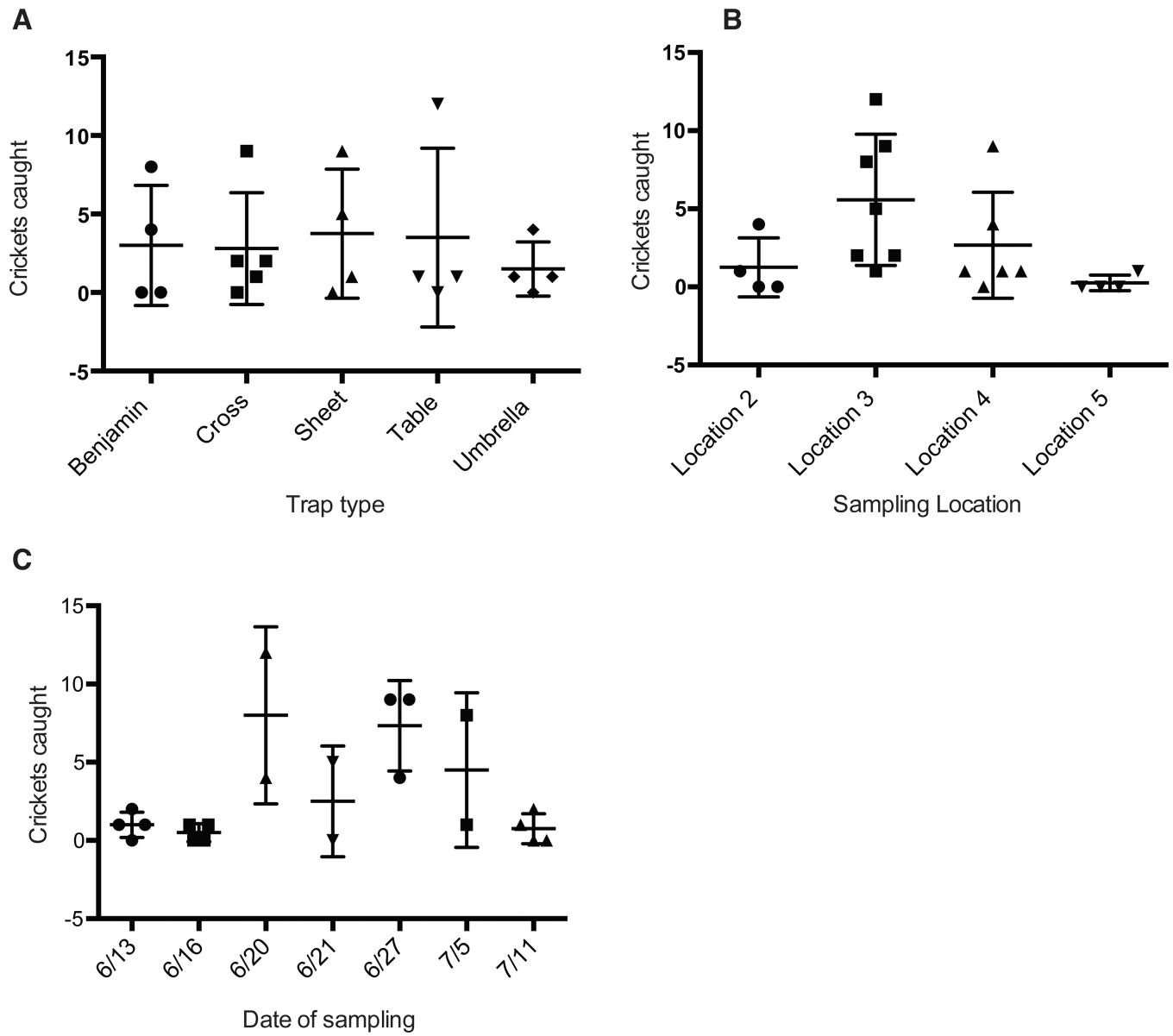

Fig. 6. Trapping data for the 5 mobile trap designs. A) Trapping data by trap type. B) Trapping data by sampling location. C) Trapping data by date of sampling.

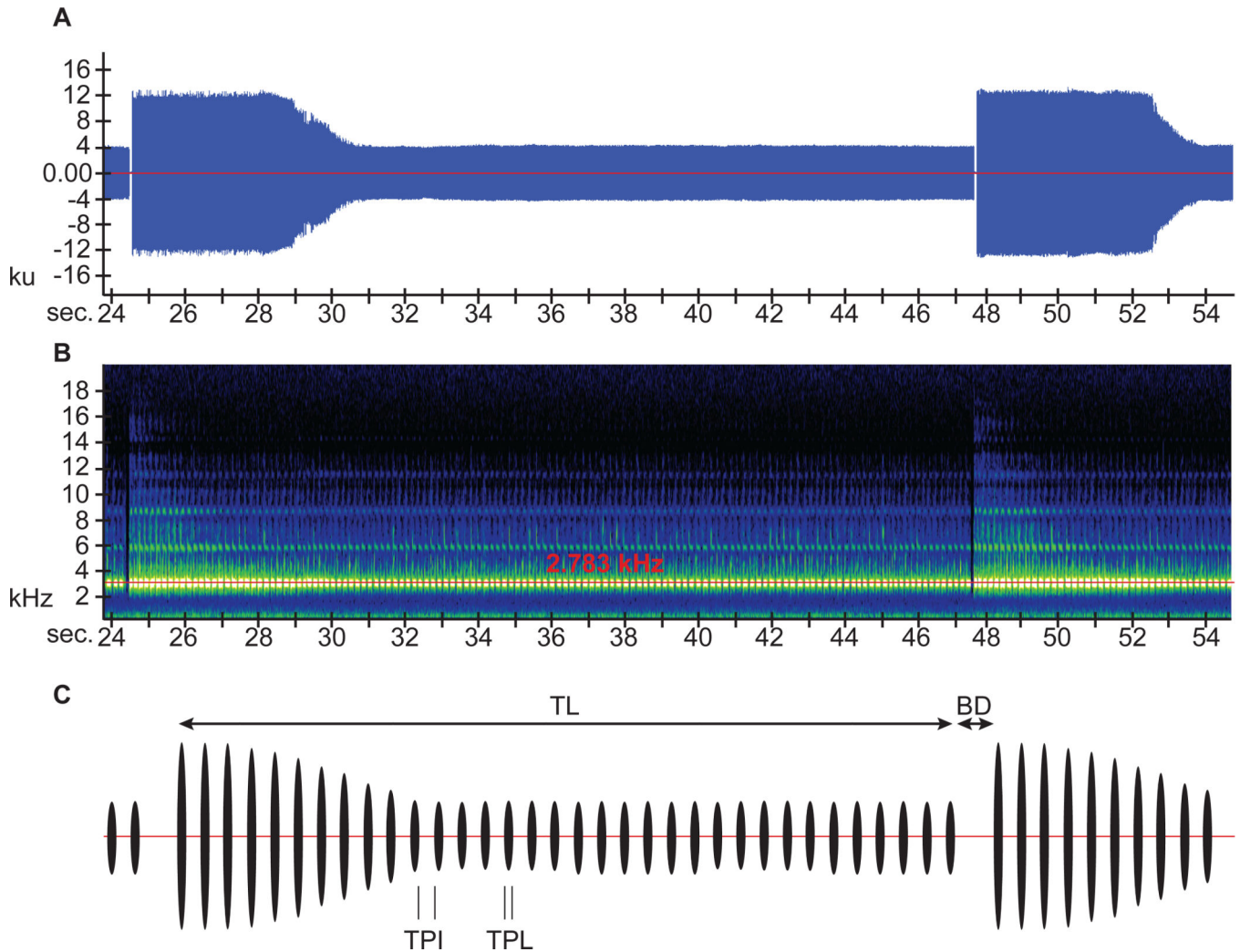

Fig. 7. Representative *S. borellii* calling song analysis from the California population. A) Oscillogram of the *S. borellii* calling song trills. B) Audiospectrogram corresponding to the above oscillogram. C) Stylized oscillogram of the *S. borellii* calling song, illustrating the parameters measured. The mean durations and values of the various song elements are presented in Table 3. TL: trill length; BD: trill break duration; TPI: trill pulse interval; TPL: trill pulse length.

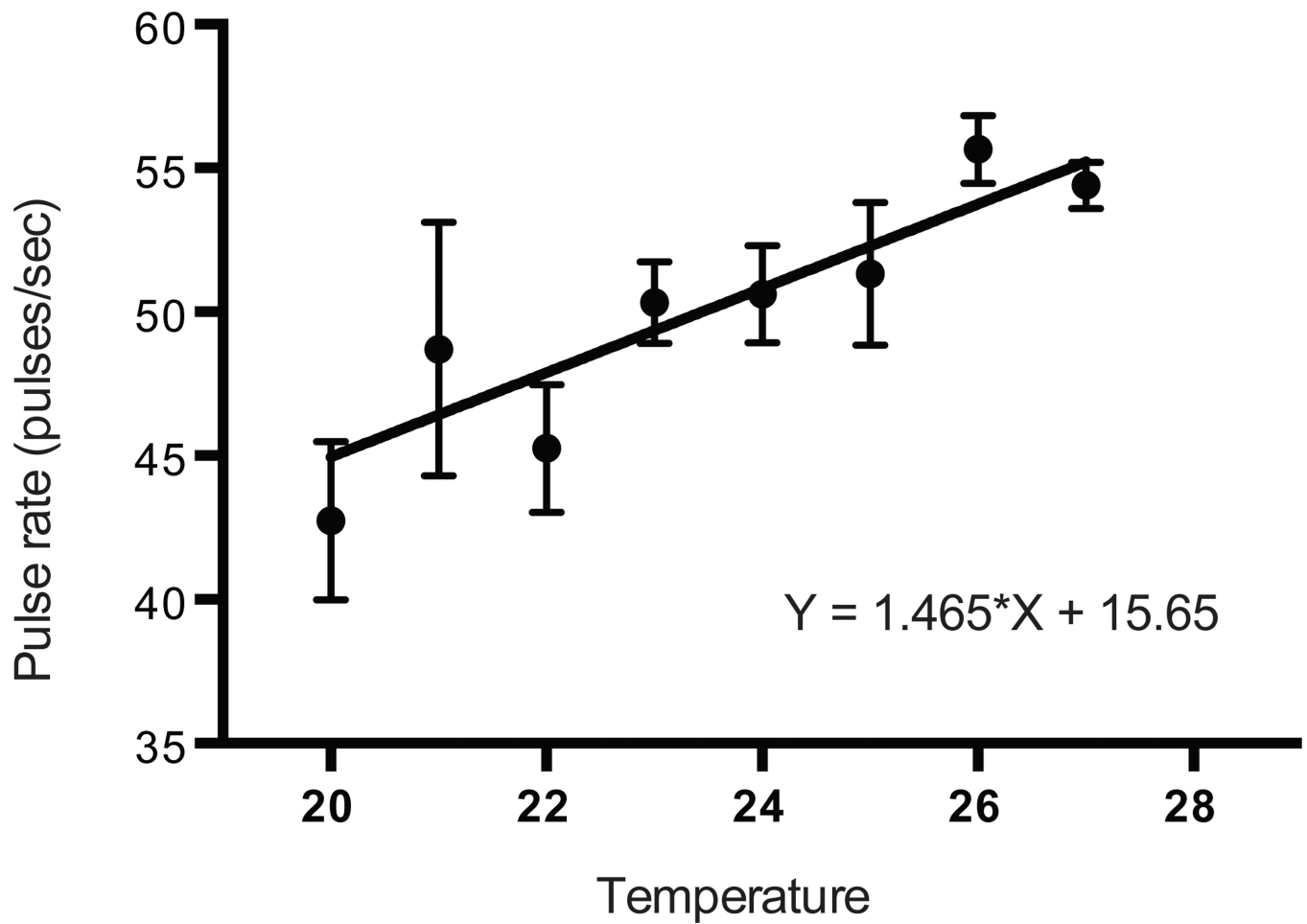

Fig. 8. The effect of soil temperature on the pulse rate of 37 *S. borellii* calling songs. Linear regression was calculated on all individual values, with vertical lines showing the range of mean values.

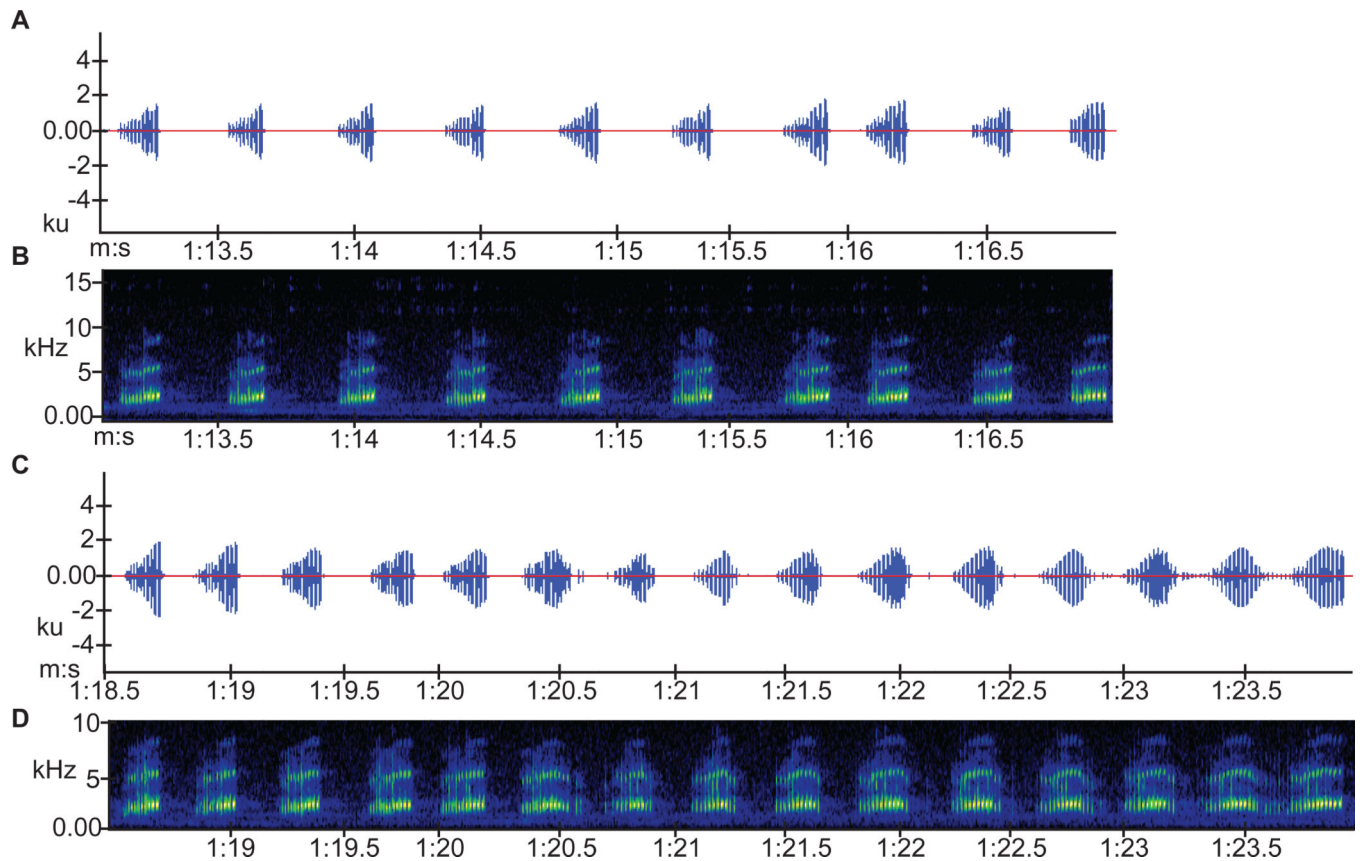

Fig. 9. Representative *S. borellii* courtship song from the California population. A) Oscillogram of courtship song. B) Audiospectrogram of the corresponding oscillogram. C) Oscillogram of courtship song illustrating a new phase of the song, with variable pulses per chirp. D) Audiospectrogram of the corresponding oscillogram.

Table 1

Number and gender of *S. borellii* caught in and around the different audio traps used. Specific details of where crickets were caught and how many days each trap was used at the different locations correlating with Fig. 5 are recorded in Table S1.

Trap Type	Females caught	Males caught	No. days tested
Semi-permanent	16	0	53
Highly portable	48	13	15

Table 3

Characteristics of male *S. borelli* calling songs. Florida data from Ulagaraj, 1976. Recorded in the field (see Methods).

Characters	California Mean \pm SD (N=37)	Florida Mean \pm SD (N=52, 70, 70)	Unpaired t test
Intensity (db)	74.73 \pm 2.36	68.5 \pm 12.8	0.0011
Carrier frequency (Hz)	2783.8 \pm 97.7	2620 \pm 140	< 0.0001
Pulse rate (pulses/sec)	50.54 \pm 3.97	54.7 \pm 4.6	< 0.0001
Trill length (TL)	16.86 \pm 16.11	-	-
Trill break duration (BD)	0.525 \pm 0.5	-	-
Trill pulse length (TPL)	0.013 \pm 0.001	-	-
Trill pulse interval (TPI)	0.007 \pm 0.001	-	-
Pulses per trill (P/T)	859.1 \pm 884.3	-	-