

Lawrence Berkeley National Laboratory

Recent Work

Title

BOUNDARY EFFECTS IN ROTATING-PIASMA EXPERIMENTS

Permalink

<https://escholarship.org/uc/item/8nk0w83h>

Authors

Kunkel, Wulf B.
Baker, William R.
Bratenahl, Alexander
et al.

Publication Date

1962-08-02

University of California
Ernest O. Lawrence
Radiation Laboratory

TWO-WEEK LOAN COPY

*This is a Library Circulating Copy
which may be borrowed for two weeks.
For a personal retention copy, call
Tech. Info. Division, Ext. 5545*

Berkeley, California

DISCLAIMER

This document was prepared as an account of work sponsored by the United States Government. While this document is believed to contain correct information, neither the United States Government nor any agency thereof, nor the Regents of the University of California, nor any of their employees, makes any warranty, express or implied, or assumes any legal responsibility for the accuracy, completeness, or usefulness of any information, apparatus, product, or process disclosed, or represents that its use would not infringe privately owned rights. Reference herein to any specific commercial product, process, or service by its trade name, trademark, manufacturer, or otherwise, does not necessarily constitute or imply its endorsement, recommendation, or favoring by the United States Government or any agency thereof, or the Regents of the University of California. The views and opinions of authors expressed herein do not necessarily state or reflect those of the United States Government or any agency thereof or the Regents of the University of California.

UNIVERSITY OF CALIFORNIA

Lawrence Radiation Laboratory
Berkeley, California

Contract No. W-7405-eng-48

BOUNDARY EFFECTS IN ROTATING-PLASMA EXPERIMENTS

**Wulf B. Kunkel, William R. Baker, Alexander Bratenahl,
and Klaus Halbach**

August 2, 1962

BOUNDARY EFFECTS IN ROTATING-PLASMA EXPERIMENTS.

Wulf B. Kunkel, William R. Baker, Alexander Bratenahl,
and Klaus Halbach

Lawrence Radiation Laboratory
University of California
Berkeley, California

August 2, 1962

ABSTRACT

The problem of current continuity and viscous drag at the boundaries in rotating-plasma experiments is discussed. We particularly emphasize a hypothetical model having a steady state with axial symmetry; it is shown that the discharge impedance derived from this model does not agree with many observations. The "Homopolar III" experiment is described in which the flux surfaces were strongly convex and parallel to the toroidal-shaped electrodes. In this way friction at the insulators was reduced. But the structure of the discharge deviated drastically from axial symmetry near the outer surface. Several studies led to the conclusion that the flow pattern probably involved secondary flows. A detailed analysis of this structure was not possible. It was also found that the rotational speed could not be raised above a few cm/ μ sec because the insulators failed in spite of the special design of the experiment.

BOUNDARY EFFECTS IN ROTATING-PLASMA EXPERIMENTS *

Wulf B. Kunkel, William R. Baker, Alexander Bratenahl,[†]
and Klaus Halbach

Lawrence Radiation Laboratory
University of California
Berkeley, California

August 2, 1962

I. INTRODUCTION

Experiments with highly ionized, rapidly rotating plasmas have been in progress for some time.¹⁻⁴ The motivation for this work has been expounded by several authors and needs little further explanation.^{5, 6} As can be seen in a brief summary of the early work given elsewhere,⁷ in all these experiments the rotation is produced by passing a radial-current pulse between the inner and outer--essentially coaxial--electrodes in the presence of a primarily axial magnetic field. The principal advantage of this procedure lies in the very effective energy transfer to ions achieved in a configuration already suitable for confinement. The main limitation, on the other hand, is that the plasma usually has to come into intimate contact with the electrodes, at least during the acceleration. Eventually these difficulties may be overcome, for instance by removal of all electrodes to large distances and by provision for adequate electron flow along the magnetic-field lines. Most experiments to date, however, seem to be very strongly influenced by boundary effects of one kind or another. For certain studies contact with surfaces might not be of particular concern, or it might be a necessary requirement, as in the work by Alfvén⁸ and Fahleson.⁹ If a fully ionized high-temperature plasma is to be generated, however, any exchange of particles with the surroundings must be minimized.

In general, the boundary effects of primary concern to us fall into three basic categories: (1) current continuity at the electrodes, (2) viscous friction at the insulators (i. e., velocity gradient along the magnetic-field lines) and (3) viscous friction at one or both of the electrodes (i. e., velocity gradient across the magnetic-field lines). We discuss these in the order listed and illustrate their consequences in connection with some recent experimental results.

II. CURRENT CONTINUITY AT THE ELECTRODES

In the macroscopic description of continuum magnetohydrodynamics no attention is paid to the nature of the current carriers. Such a simple model becomes inadequate, however, when (1) the transport properties are anisotropic, (2) the Hall effect enters into the problem, and (3) electrodes are involved. For one-dimensional phenomena, inclusion of the first of these refinements is, of course, trivial. The Hall effect, on the other hand, usually leads to complications, particularly when electrodes are required to connect the plasma to an external circuit.

If the current between the electrodes is carried by electrons only, and if these electrons pass smoothly from the cathodes into the plasma and are subsequently collected by the anodes, then the simple continuum magnetohydrodynamic description is perfectly adequate. In highly-ionized rotating plasmas with axial symmetry the driving current tends to be carried by ions, however, rather than by electrons. This follows immediately from the generalized Ohm's Law for slowly varying currents:¹⁰

$$\underline{c}\underline{E} + \underline{v} \times \underline{B} - \frac{c}{en} \underline{j} \times \underline{B} + \frac{c}{en} \nabla p_e = \underline{rj}. \quad (1)$$

We write all equations in this paper in the Gaussian (symmetric cgs) system of units with conventional meanings for symbols.¹⁰ In particular, note that the symbol \underline{v} here denotes the velocity of the mass flow of the material and terms of order m_e/m_i are neglected when compared to terms of order unity.

It is convenient to introduce a right-handed orthogonal set of curvilinear coordinates (n, ϕ, s) appropriate for systems with general axial symmetry. The unit vector \underline{e}_n points in the direction of the outward normal of the axisymmetric magnetic-flux surfaces, while \underline{e}_ϕ is the ordinary azimuthal direction. The unit vector \underline{e}_s is given by $\underline{e}_s = \underline{e}_n \times \underline{e}_\phi$; i.e., it is tangent to the flux surfaces and lies in a plane with the axis of symmetry.

Such a coordinate system is not very useful when the flux surfaces cannot be described analytically and when they vary in time. For our discussions, however, the coordinates can be considered as instantaneously stationary, and some of the resulting component equations take on very simple forms. The ϕ component of Eq. (1), for instance, can be solved directly for v_n ,

$$v_n = \frac{cE_\phi}{B_s} - \frac{r}{B_s} + \frac{c}{en} j_n, \quad (2)$$

where the subscripts indicate the components of the vectors \underline{v} , \underline{E} , \underline{B} , and \underline{j} along the directions \underline{e}_n , \underline{e}_ϕ , and \underline{e}_s . The azimuthal component of the pressure gradient was set equal to zero because of the assumed axial symmetry. The component E_ϕ does not vanish everywhere, however, as long as the currents, particularly j_ϕ , are not completely stationary.

The first term on the right describes the centrifugal displacement of the flux surfaces themselves. Its consequences have been studied extensively.^{1, 2, 3, 11} The other two terms represent transport of mass across the magnetic-flux surfaces. The middle one is due to resistive slip driven by the centrifugal force and, like the first term, is always outward. The last term is directed from the anode to the cathode and shows that when nj_ϕ and E_ϕ are sufficiently small, practically the entire current j_n must be carried by ions.

This result is not new, of course, and it has been pointed out by several authors that an electron sheath should form between the anode and the plasma proper if the anode cannot serve as an ion source.^{1, 12} Such an electron sheath would constitute an $\underline{E} \times \underline{B}$ "slipping stream," however, with enormous shear stress and as such is certainly expected to be unstable.¹³⁻¹⁶ Consequently, their flow no longer being laminar, the electrons

are able to cross the magnetic field and drain off towards the anode. This entire process provides current continuity and creates a virtually evacuated region between the anode and the plasma. A detailed analysis of this process is very complex. It is, for instance, likely that pressure gradients can no longer be neglected for such a sheath. Moreover, there is some doubt whether the initial assumption of azimuthal symmetry will still be consistent with the existence of an unstable anode sheath.

Alternatively, we may speculate that under such conditions of evacuation adjacent to the anode surface, gas is likely to be evolved at a substantial rate. This gas may get rapidly ionized by the electrons of the insipient sheath so that the metal surface may act effectively as an apparent ion source after all. While such a process cannot be operative for extended times because it leads to depletion, it seems possible that short pulses of reasonable current density may, in fact, be emitted transiently by the anodes in all crossed-field plasma-acceleration processes.

It is also interesting to speculate on the possible advantages of having the electric-field vector pointing radially inward; i. e., to select the outer cylindrical electrode as the anode in the rotating-plasma experiments. In this case the last term on the right of Eq. (2) opposes the first two, and one might wonder whether the discharge under these conditions will not simply operate in a manner such that the boundary condition $v_n = 0$ is satisfied at the anode. Because of finite heat conduction, diffusion, and viscosity, the resistivity η will be large and v_ϕ must necessarily be small in the immediate neighborhood of the surface. But it would again take a detailed analysis to establish whether the required conditions are realizable in practice.

There is no experimental evidence, at least in our own experiments, that the discharges behave better when the outside electrode is used as the

anode than when it is used as the cathode. On the contrary, the actual mode of operation shows drastic deviations from the assumed azimuthal symmetry whenever the axially symmetric anode is forced to be in intimate contact with the revolving plasma (see Sec. VI).

Nevertheless, the preceding discussions are not of academic interest only. In one of our early experiments with rotating plasmas it was demonstrated that a region filled with plasma can act very effectively as a virtual anode capable of emitting the necessary ion current. The observations were made on the device called Homopolar II, which was very similar in design to the Hydromagnetic Capacitor described before.¹ The quartz discs used as insulators separating the plasma from the pillbox-shaped metal container had a smaller diameter than the chamber itself, so that approx 1/2-in. -wide annular rings of the top and bottom metal surfaces were exposed to the plasma. Small metal plates connected to separate leads were introduced through the side and mounted as indicated schematically in Fig. 1.

When the discharge was oscillating it could be demonstrated that most of the current passed through probe A when the latter was a cathode and through probe B when it was an anode. The interpretation we have given is as follows: When the outside is the cathode, more ions are collected by probe A than electrons are emitted by probe B. When the outside is the anode, however, ions are drawn from the plasma existing in this region. The electrons that are left behind are constrained to drain off along the magnetic-field lines and hence are collected by probe B only. No ions are emitted by probe A. The currents to these localized probes were synchronous with and proportional to the total current through the plasma, indicating that the current in this discharge was azimuthally symmetric.

It is concluded that a reservoir of ionized gas stored in a "hollow" electrode behind a magnetic-flux surface can serve very well as a virtual

anode capable of emitting substantial ion currents when needed for the efficient acceleration of plasma. The Moscow Ion Magnetron experiment is an excellent example of such an arrangement.⁴

III. THE STEADY STATE WITH FINITE VISCOSITY

Revolving-plasma flows produced by radial currents usually contain radial shear. If the driving current is stopped and if no friction exists between the plasma and the stationary boundaries, any finite viscosity within the plasma will damp out this shear and eventually only rigid-body rotation will persist. During this process the total angular momentum of the plasma will stay constant. Conversely, if the plasma slows down and comes to rest in the absence of currents outside the plasma, it must be concluded that the angular momentum is somehow transferred to the surroundings by an essentially mechanical process; i. e., by friction at the boundaries. The energy, in this case, is usually dissipated primarily in the fluid itself, although possibly in a thin boundary layer. The plasma may, of course, lose all this energy again very rapidly by radiation and by general heat transfer to the surroundings.³

If the electrodes remain connected to a constant-voltage power supply, the electric field integrated from one electrode to the other is not permitted to change. This means the average rotation of the plasma is not allowed to decrease in spite of any viscous drag. A steady state is eventually reached, akin to Poiseuille flow in hydrodynamics, where the viscous-shear stress is just balanced by a suitable applied force. For a rotating plasma this force is not due to a pressure gradient or gravity as it usually is in ordinary hydrodynamics, but is a $\underline{j} \times \underline{B}$ body force where the current density \underline{j} must be supplied by the power supply. It should be pointed out that the driving current j_n which flows in these axisymmetric configurations requires the presence of axial components of current in regions near the axis, thus causing an azimuthal component $B_\phi \neq 0$ which varies with position. A curvature (rather than a gradient) of the magnetic field results making analytic treatments cumbersome.

In most experiments the revolving-plasma flow is established rather abruptly by a large-current pulse during which the viscous drag can be neglected. Therefore, during this phase the features of most interest are the distortion of the magnetic field resulting from the centrifugal force, and the boundary problems at the electrodes. Under many conditions this initial phase is followed by an extended period of a nearly steady state, which may last for many hundreds of microseconds, depending primarily on the total energy available in the driving power supply. If one wishes to describe this phase of the discharge as a stationary flow, the foregoing considerations of viscous effects are of primary importance. For a simplified analytic treatment of this problem we can attempt to use the macroscopic equation of motion of a conducting fluid of finite viscosity,

$$\rho(\underline{v} \cdot \nabla) \underline{v} = \underline{j} \times \underline{B} - \nabla p + \nabla(\mu \nabla) \underline{v}, \quad (3)$$

where the last two terms together, so far, stand only symbolically for the divergence of the complete stress tensor. If there is an axisymmetric steady state, the azimuthal component of Ohm's law is given by Eq. (2) with $E_\phi = 0$. The longitudinal component is not of much interest in this development, but the normal component becomes

$$cE_n + v_\phi B_s - v_s B_\phi + \frac{c}{en} (\nabla_n p_e + j_\phi B_s - j_s B_\phi) = \eta j_n. \quad (4)$$

Fortunately, quantitative estimates indicate that in the rotating-plasma experiments that are actually being performed, all but the first two terms on the left side can usually be neglected. Similarly, v_n as evaluated from Eq. (2) for the steady state, as well as v_s , j_s , and $(\nabla p)_n$ can be ignored in Eq. (3). If we furthermore assume for simplicity that the viscosity is isotropic and independent of position, the three components of Eq. (3) reduce to

$$-\frac{\rho v_\phi^2}{r} \cos \alpha = j_\phi B_s, \quad (5)$$

$$-\frac{\rho v_\phi^2}{r} \sin \alpha = j_n B_\phi - (\nabla p)_s, \quad (6)$$

and

$$0 = j_n B_s + \mu (\nabla^2 v)_\phi, \quad (7)$$

where r denotes the distance from the axis of rotation and the angle α is defined by $\sin \alpha = B_r/B_s$. This set must still be augmented with Maxwell's equation $\nabla \times \underline{B} = 4\pi \underline{j}$ as well as with a relation between p and ρ , and boundary conditions on \underline{v} , \underline{B} , and \underline{E} . Obviously, self-consistent solutions of the stationary-flow problem outlined above will, in general, still be exceedingly complex and we do not attempt to obtain them here. The equations of motion were written in this form primarily to summarize once more very briefly the most important features of idealized rotating plasmas.

Equation (5) relates the centrifugal force to the so-called "diamagnetic" current j_ϕ , knowledge of which is needed in Eq. (2) for the evaluation of v_n . Equation (6) describes the macroscopic "centrifugal confinement" of rotating plasmas which is superimposed on the ordinary pinch effect $j_n B_\phi$ whenever the flux surfaces are convex (i.e., when $\frac{s-s_0}{a} < 0$ everywhere, where $\alpha = 0$ on some surface given by $s_0 = \text{constant}$). Finally, Eq. (7) expresses the obvious fact that steady rotation in the presence of friction is possible only if a steady driving current j_n is supplied. Furthermore, it is clear that for a given shear stress this driving current is inversely proportional to the magnetic field. In the remaining discussions we will be primarily concerned with the implications of Eq. (7).

Some insight into the nature of possible flow patterns is readily obtained if we make drastic simplifying assumptions about the flux distribution and hence also about the natural coordinate system introduced earlier. If, for

instance, \underline{e}_s is parallel to the axis of rotation everywhere, we have simple cylindrical coordinates with $n \equiv r$ and $s \equiv z$; Eq. (7) becomes

$$\frac{v_\phi}{r^2} - \frac{1}{r} \frac{\partial v_\phi}{\partial r} - \frac{\partial^2 v_\phi}{\partial r^2} - \frac{\partial^2 v_\phi}{\partial z^2} = \frac{j_r B_z}{\mu} \quad (8)$$

Because of the requirement $\nabla \cdot \underline{j} = 0$ for stationary currents and because of the earlier assumption that $j_z \approx 0$, we can further substitute

$$j_r(r, z) = j_r(r_0, z) r_0/r \quad (9)$$

where r_0 is any suitable radius such as that of the outer electrode. Further $j_r(r_0, z)$ can be eliminated by means of Ohm's law, Eq. (4), which now reads

$$cE_r + v_\phi B_z = \eta j_r \quad (10)$$

Note that the new unknown, E_r , which is introduced by Eq. (10), is independent of z since $\nabla \times \underline{E} = 0$ and $\partial E_z / \partial r$ may be considered negligible in this approximation. Equation (8), after the substitutions (9) and (10), can then be solved if $B_z(r)$ is prescribed and the boundary conditions for v_ϕ are given. Actually, we must simultaneously solve for v_ϕ and $B_z(r)$ with the help of Eqs. (5) and (6) where now $a = 0$. But the centrifugal distortion of B is negligible if

$$\frac{r}{B_z} \frac{\partial B_z}{\partial r} = \frac{4\pi r}{B_z} j_\phi = \frac{4\pi \rho}{B_z^2} v_\phi^2 \ll 1 \quad (11)$$

In other words, when the rotational speed is much smaller than the Alfvén velocity, B_z can be considered as unaffected by the flow.

IV. VISCOUS FRICTION AT THE INSULATORS

If the plasma is allowed to be in contact with a rigid surface $z = z_1$, this surface must be an insulator because, as stated before, E_r must be finite there. If, in addition, at this surface the boundary condition $\underline{v} = 0$ is imposed (no slip) the term $\partial^2 v_\phi / \partial z^2$ in Eq. (8) must also be finite. Therefore, j_r is forced to be a function of z and it has been shown that, for uniform B_z at least, and for typical conditions of rotating plasma experiments, the current would tend to concentrate in thin boundary layers close to the insulators.^{17, 18} In any such numerical calculation it is assumed that the coefficients ν and μ which enter the problem can be estimated from kinetic theory, and that all Larmor radii are small enough so that the macroscopic description represents a good approximation. Note that the "Hartmann"-type boundary layers at the insulators are predicted to be stable for the large Hartmann numbers $M = BL(\eta\mu)^{-1/2}$ encountered in the laboratory (when the conducting fluid is plasma rather than mercury).^{19, 20} But since the layers are expected to be thin, they probably are very sensitive to surface roughness, and since they tend to carry high current densities, they are likely to cause surface erosion and insulator failure.

Therefore, it is most essential that the plasma not be subject to viscous friction at the insulators. It should, for instance, be possible to design an experimental arrangement with a very long axial dimension such that the $j_n B_\phi$ "pinch effect" of Eq. (6) forces p to vanish at these surfaces even if $\sin \alpha = 0$. It is much more practical and attractive, however, to make use of the centrifugal effect and convex flux surfaces in order to drive the plasma away from the insulators. Undoubtedly this objective was at least partially accomplished in the Ixion experiment, where a "magnetic mirror" configuration was used.³ Even more strongly curved geometries have been introduced in two other recent investigations,^{17, 21} one of which is discussed in

detail in Section VI of our paper.

Another promising attempt to avoid contact between the plasma and the insulators is being made in the Homopolar V experiment in which the gas is injected into and the plasma is created in the center of a very long evacuated mirror machine.²²

V. VISCIOUS FRICTION AT THE ELECTRODES

While the friction at the end plates can in principle be avoided, some contact with electrode surfaces must usually be taken into consideration. If we assume as a simplification for illustrative purposes that the geometry is still cylindrical and B_z is uniform, Eq. (8) is still applicable and the term $\partial^2 v_\phi / \partial z^2$ can now be neglected. This means Eq. (8) is independent of z , and Ohm's law [Eq. (10)] is not needed. The solution then is found to be a Poiseuille-type flow pattern:

$$v_\phi = \frac{j_r(r_0) B_z r_0}{2\mu r} (C_1 + C_2 r^2 - r^2 \ln r), \quad (12)$$

where the constants C_1 and C_2 must be evaluated from the boundary conditions on v_ϕ . For instance, if the outer surface is rigid and there is no slip we must have $v_\phi(r_0) = 0$. If the inner boundary, on the other hand, is free at $r = r_i$, then the stress there must be zero; i. e., $\partial v_\phi / \partial r = v_\phi / r$ at $r = r_i$. The resulting flow is given by

$$v_\phi = \frac{j_r(r_0) B_z r_0}{4\mu r} \left[r^2 \ln \frac{r_0^2}{r^2} - r_i^2 \left(1 - \frac{r^2}{r_0^2} \right) \right]. \quad (13)$$

We can now directly obtain the electric-field distribution $E_r(r)$ by using Eqs. (10) and (13); it is interesting to note that the form obtained fits the observations made on Ixion better than the undistorted vacuum field shown by Baker et al.³ This may be fortuitous, however, because, as Baker et al. have already pointed out, the viscosity μ deduced in this way appears to be unreasonably high. A very direct quantitative evaluation is obtained if the resistance R_1 of a unit length of such a steadily rotating discharge is calculated from Eqs. (10) and (13),

$$R_1 = \frac{c}{2\pi r_0 j_r(r_0)} \int_{r_i}^{r_0} E_r dr = \frac{\eta}{2\pi} \ln \frac{r_0}{r_i} + \frac{B_z^2 r_0^2}{4\pi\mu} \left(1 - \frac{r_i^2}{r_0^2} \right)^2. \quad (14)$$

The first term on the right represents the ordinary electric resistance of the plasma and can usually be assumed negligible. The second term is due to the viscous dissipation. Since the ordinary viscosity coefficient is expected to decrease with increasing magnetic field, the total resistance should increase with more than the second power of B_z . This behavior is clearly not observed. We must therefore conclude that the drag is enhanced by an anomalous viscosity or, more probably, that the actual flow pattern cannot at all be approximated by the laminar axisymmetric conditions underlying our analysis. Indeed, the probe measurements in Exion as well as in some of our own observations (see Section VI) indicate that the structure of the plasma near the outer electrode is not necessarily axially symmetric.

VI. THE HOMOPOLAR III EXPERIMENT

A. General Description

Since the most serious limitation in the work with rotating plasmas invariably involved failure of the insulators, we have attempted a drastic solution of this problem in the device called Homopolar III (see Fig. 2). This work was started in 1958 and discontinued early in 1960. A very brief description of the experiment has been given before.¹⁷ The geometry was similar to one suggested by us earlier⁷ and resembled that used in recent experiments at Stockholm.²¹ Its containment properties have been considered in some detail by Bonnevier and Lehnert.⁶ The principal features of our arrangement were as follows. The flux surfaces (4) were nearly toroidal because the magnetic field was generated by a pulsed ring current flowing in a circular coil (7). This "field coil" was embedded inside the inner electrode and connected via welding cables (8) and ignitrons to a 5-kV 12,000- μ F electrolytic-capacitor bank. The inner electrode (3) was made of thin stainless steel so that the magnetic field (3 to 10 kG) could easily pass into the space between the electrodes. The outer electrode (1), on the other hand, was made of 0.5-in. thick high-conductivity aluminum alloy which amounted to about one skin depth at the frequency corresponding to the half-cycle time of the magnetic field (approx 100 cps). The amount of flux leaking through the outer shell during the first 2.5 msec was therefore insignificant. Except for some leakage at the top and bottom edges of the electrodes, then, the flux surfaces were fairly parallel to the electrodes. Two auxiliary field coils, not shown in the figure, were at times placed as "trimmers" on the outside just above and below the outer shell. These could be operated with dc currents so that their fields would penetrate through the aluminum and

locally add to (or subtract from) the pulsed field of the coil (7).

The insulators (2) were straight cylinders 12-in. diam and 6-in. high made of Pyrex, ceramic, or initially even of plexiglass. The Pyrex was too fragile and the plexiglass contaminated the plasma very much (although it was not too badly attacked by the discharge!) The ceramic insulators, which were described as high grade (98%) alumina by the manufacturer, were most satisfactory although they, too, discolored slightly after prolonged operation. Rubber-gasket seals were made between the insulators and both electrodes so that the space between the latter could be pumped out to pressures well below 10^{-3} -mm Hg. The major diameter of the entire device was 24 in. and the total volume enclosed was about 10^5 cm³. The operating gas was bled in through a needle valve (10) and continuously removed through the pump line (11). Obviously, the system was not intended for high-purity plasma work.

The primary purpose of the experiment was the study of a highly ionized rotating plasma which has no contact whatsoever with the insulator surfaces. The geometry described above should be suitable, according to Eq. (6), if the gas is fully ionized and v_ϕ is much larger than the random speed of the ions. Such a supersonic flow can be established if the ionization process can be made to take place in a low electric field which is allowed to rise gradually. The criterion for this condition of "reversible" acceleration is that $E_n/E_n \ll \omega_{ci}$, where $\omega_{ci} = eB/cm$ is the ion gyrofrequency. Stated differently, the driving current supplied by the set of coaxial cables (9) must be limited so that $cj_n \ll env_\phi$ at all times. In the upper sketch of Fig. 2 we show an extreme case for a cold plasma compressed by the centrifugal force to form a flat ring in the equatorial plane (6). The electric field (5) is indicated as pointing inward; i. e., the outer shell is taken as the anode.

In actual operation the above conditions were only partially realized. Particularly, the ionization phase in a low electric field could never be clearly established. Usually hydrogen or deuterium gas was used at initial pressures between 5 and 100- μ Hg. The driving current was supplied by a 10-kV 600- μ F condenser bank which was connected to the electrodes by a set of ignitrons at the moment the magnetic field reached its peak value. By and large, the voltage and current behavior of the discharge was very similar to that of earlier Homopolar experiments¹ but was extended in time scale to the point of being practically indistinguishable from the Ixion experiments reported more recently.³ In particular, the rotational state (voltage-holding mode) usually lasted for more than 500 μ sec and the quasi-stationary (holding) voltage could never be raised above about 3 kV. This meant that the steady-state rotational velocities on the average were only a few times 10^6 cm/sec. Short-circuiting experiments¹ showed that the amount of revolving material and its moment of inertia remained fairly constant up to starting potentials of 5 kV and, indeed, no appreciable distortion of the magnetic field by the centrifugal force was expected. Unfortunately, beyond 5 kV the "hydromagnetic capacity" of the rotating plasma increased rapidly with the applied voltage reaching five times the initial value at 7.5 kV. At the same time the gas pressure increased markedly after each discharge. There could be no doubt that large quantities of gas were evolved from the surfaces under these conditions, and that the diamagnetic displacement of the flux surfaces must have been appreciable. This behavior at elevated voltages apparently was very different from that reported for the Ixion device.³ Since no other very significant conclusions could be drawn from such simple external observations, further details of these findings need not be given here.

B. Current Distribution at the Electrodes

The overall results were clearly disappointing. Localized measurements were required to establish whether the plasma was in fact confined to the equatorial regions. Observations with probes immersed into the plasma region proved to be rather unsatisfactory in this geometry. It was easy to isolate small regions (so-called current buttons), however, in the outer electrode and connect them to the (grounded) shell via low-inductance paths of small but finite resistance ($0.1\ \Omega$). The local current density to the electrode could thus easily be observed by means of oscilloscopes. A set of four such current buttons was installed along the perimeter of the machine, and along the "meridian" line of one of these machines two more buttons were mounted at 30° and 60° above the "equatorial" plane. The results were astonishing.

In view of the arguments presented in Section II the outer electrode was usually chosen to be the anode. In that case it was noted that the local current density invariably fluctuated wildly and irregularly during the acceleration phase and steadied down to rather regular short pulses (approx $2\text{-}\mu\text{sec}$ duration) during the nearly steady voltage-holding phase. The amplitude of these pulses was about three orders of magnitude lower near the insulators than in the "equatorial" region. Typical oscilloscope traces are shown in Fig. 3. Analyses of the phases of these pulses at the various locations along the perimeter disclosed that the current pattern consisted of 10 to 13 spokes moving roughly with the estimated mean speed of the revolving plasma. It was also established that the main current entered the anode first in the equatorial region and spread within about $10\ \mu\text{sec}$ all the way up to the region 60° above the equator. During the nearly steady rotation the regularly spaced spokes also extended about 50 cm to either

side of the equator exactly along the magnetic-field lines. They were about 2-cm wide at the equator, narrowing with distance from it, and the total current in each amounted to 100 to 200 A. We made unsuccessful attempts to suppress this banded structure of the anode current by deflecting the outer flux surfaces into the aluminum shell near the top and bottom end of the machine (using the auxiliary dc coils mentioned above). These failures, however, may have been caused by the lack of power available to adequately energize the trimmer coils.

When the outer shell was used as the cathode, the banded structure of the current was much less pronounced. A steady background current appeared, presumably due to ion collection, and the regular pulses were weak but occasional very sharp peaks were observed. These latter were undoubtedly caused by erratic cathode spots.

C. Structure of the Discharge

Evidently, it was very important to determine how far into the interior of the discharge these spokes reached. We were also interested in finding out whether the extent of the spokes along the flux lines was a measure of the thickness of the plasma and whether the plasma density had a ribbed structure as sharply defined as the anode current. As mentioned before, electric- or magnetic-field probes protruding into the interelectrode space did not yield usable results. A small double Langmuir probe, however, when inserted very little beyond the anode surface through the port of one of the current buttons, gave a hint of a small E_{ϕ} component appearing simultaneously with each current spoke.

When a small quartz rod was thrust through a hole in a current button into the interior, the current collected by that button had a steady component superimposed on the regular pulses. We interpreted this as evidence for

a nearly steady motion of a finite plasma that extends into regions between the spokes. The magnitude of this current increased uniformly with the length of the rod. Evidently, the stopping of the plasma by the rod caused current flow along the rod to the anode. This effect was very pronounced in the equatorial plane and was very feeble at a position 50 cm above this plane. We concluded that the plasma was indeed confined to a region subtended by an angle of approximately 45° on either side of the central plane.

Piezo-electric probes were used in an attempt to explore the pressure fluctuations in the plasma. If those probe observations are accepted at face value, it can be inferred that the spokes in the central plane are accompanied by pressure pulses of about 15% above the "steady" level. Unfortunately, these measurements could not be extended to regions outside the equatorial plane.

Since the plasma was clearly very tenuous near the insulators, magnetic search coils could be introduced there without interfering with the discharge. In this way it was discovered that flashes of current along the insulators occurred whenever the initial voltage was raised above 5 kV. These findings were qualitatively very similar to those reported on the Ixion experiment.³ They were disappointing to us because the entire experiment had been specifically designed to avoid them. Evidently, the centrifugal-pumping action of this device was inadequate to remove the surface gas from the ceramic material well enough to prevent failure under the severe conditions of irradiation from the plasma. The copious liberation of gas noted in these cases could then readily be ascribed to the discharges along the insulators.

VII. DISCUSSION

It is clear from the findings reported here and elsewhere^{3, 4, 23} that neither the flow nor the current distribution in rotating plasmas is usually completely axisymmetric, at least in the neighborhood of the outer bounding surface if this surface is an electrode in contact with the plasma. In the case of the Homopolar III experiment, the observed phenomena did not appear to be turbulent, however, but rather suggested the existence of well-behaved, fairly regular flute-shaped structures. It is tempting to speculate that the discharge involved stationary secondary flows of some form which naturally would assume a cellular pattern. This speculation is certainly in keeping with the fact that the spacing between the observed spokes roughly equaled the distance between the electrodes. However, an analysis yielding predictions concerning stable flow patterns in this geometry is a formidable task, since it would have to be based on hydromagnetic stability calculations of Poiseuille-type flows in curved channels. Only a few general remarks can be made.

The analysis of stability of Poiseuille motion is difficult even in ordinary hydrodynamics and in perfectly straight channels.²⁴ The hydro-magnetic problem is probably still more complicated. The special case of flow parallel to a straight and uniform magnetic field has been worked out, however, and it was found, of course, that the field can have a strong stabilizing effect.²⁵ The crossed-field motion, of interest in the present context, has apparently not yet been attacked. Here the stabilizing effect of the magnetic field is expected to be much weaker if not totally absent because the one-dimensional problem seems to become independent of the field. As a first approximation, then, we may regard the stability problem for parallel crossed-field flow as a purely hydrodynamic one.

For rotation the situation is not so simple. Unfortunately, even in ordinary hydrodynamics the stability of revolving Poiseuille motion has never been analyzed for the modes of interest here. Only axisymmetric perturbations (Taylor instabilities) have been studied because in the absence of a magnetic field these are by far the most important ones. It is likely, on the other hand, that for the rotating plasmas under discussion all "m = 0" modes are completely stabilized because the Hartmann numbers based on the electrode spacing are always very large. While this statement has not been proven rigorously it is inferred simply from the stability of hydro-magnetic Couette flow. The latter has been studied extensively in recent years by Chandrasekhar and others²⁶ and the stabilizing effect of the axial magnetic field has been clearly demonstrated.²⁷ Only axisymmetric perturbations have been considered so far, however, even in the problem of this Couette flow between revolving cylinders.

The fact that the spokes were in phase along the magnetic-field lines can be taken as an experimental confirmation of the above inference. It is also evident that the problem of flute instabilities in rotating plasmas cannot simply be reduced to a question in ordinary hydrodynamics. The reason for the difference is that the centripetal force in such rotating plasmas must be derived from a body force $\underline{j} \times \underline{B}$ while in hydrodynamics it is always ascribed to a pressure gradient. Indeed, the Reynolds number, $Re = \rho v_{\phi} r / \mu$, for the rotating plasmas in question, is usually rather low, certainly much less than 1000, whereas for onset of hydrodynamic turbulence in straight Poiseuille motion this number²⁴ has to be at least 5000. In other words, the inferred secondary flow is most likely initiated by a hydromagnetic rather than a hydrodynamic instability--but a full understanding is still lacking.

In experiments with convex flux surfaces, in which the plasma is compressed along the field lines by the centrifugal effect, one's difficulties are compounded because the secondary flows in all likelihood are three-dimensional. This is directly seen on inspection of Eq. (6). Since the velocity close to the surfaces is very low, the centrifugal component there becomes negligible and the plasma can escape along the field lines. It is quite possible that this effect contributes to the insulator failure at elevated power levels.

To all these arguments we have to add the considerations of the charge transport discussed in Section II. If the motion is not completely axisymmetric, azimuthal components of electric field can well exist in the interior of the plasma; therefore, some of the charge flow may be due to electron drift towards the anode. Obviously, such regions must be periodic along concentric circles, just as observed. Only in the immediate neighborhood of the anode we have to invoke small-scale instabilities of an electron sheath rather than azimuthal fields to permit charge collection at that surface. Ion emission would, in that case, not be needed. Because of the speculative and vague nature of this discussion, however, a more detailed analysis of the possible modes of charge transport does not seem justified.

In summary we conclude that the anomalous dissipation in our rotating plasmas can probably be ascribed to a complex flow pattern rather than to a small-scale turbulence which might enhance both resistivity and viscosity.

FOOTNOTES AND REFERENCES

- * This work was performed under the auspices of the U.S. Atomic Energy Commission.
- † Present address: Jet Propulsion Laboratory, Pasadena, California.
1. O. A. Anderson, W. R. Baker, A. Bratenahl, H. P. Furth, J. Ise Jr., W. B. Kunkel, and J. M. Stone, Study and Use of Rotating Plasma, in Proceedings of the Second United Nations International Conference on the Peaceful Uses of Atomic Energy (United Nations, Geneva, 1958) Vol. 32, p. 155; Oscar A. Anderson, William R. Baker, Alexander Bratenahl, Harold P. Furth, and Wulf B. Kunkel, *J. Appl. Phys.* 30, 188 (1959).
 2. K. Boyer, J. E. Hammel, C. L. Longmire, D. Nagle, F. L. Ribe, and W. B. Riesenfeld, Theoretical and Experimental Discussion of Ixion, a Possible Thermonuclear Device, in Proceedings of the Second United Nations International Conference on the Peaceful Uses of Atomic Energy (United Nations, Geneva, 1958) Vol. 31, p. 319.
 3. D. A. Baker, J. E. Hammel, and F. L. Ribe, *Phys. Fluids* 4, 1534 (1961); D. A. Baker and J. E. Hammel, *Phys. Fluids* 4, 1549 (1961).
 4. E. E. Yushmanov, in Plasma Physics and the Problem of Controlled Thermonuclear Reactions, edited by M. A. Leontovich (Pergamon Press, New York, 1960) Vol. IV, p. 277.
 5. C. L. Longmire, D. E. Nagle, and F. L. Ribe, *Phys. Rev.* 114, 1187 (1959).
 6. B. Bonnevier and B. Lehnert, *Arkiv Fysik* 16, 231 (1959).
 7. J. M. Wilcox, *Rev. Mod. Phys.* 31, 1045 (1959).
 8. H. Alfvén, *Rev. Mod. Phys.* 32, 710 (1960).

9. U. V. Fablesen, *Phys. Fluids* 4, 123 (1961).
10. L. Spitzer, *Physics of Fully Ionized Gases* (Interscience Publishers, Inc., New York, 1956), p. 21.
11. B. Lehnert, *Nuclear Fusion* 1, 125 (1961).
12. C. L. Longmire, Plasma Physics, Chapter III (to be published); available from author.
13. O. Buneman, *Nature* 165, 474 (1950).
14. G. G. MacFarland and M. G. Hay, *Proc. Phys. Soc. (London)* 63B, 409 (1950).
15. M. E. Ebel and S. B. Treiman, Los Alamos Scientific Laboratory Report LA-2408, p. 16 (1959).
16. C. W. Hartman and D. H. Sloan, Turbulence in Crossed-Field Electron Streams (University of California, Electronics Research Laboratory, Berkeley, unpublished).
17. W. R. Baker, A. Bratenahl, A. W. DeSilva, and W. B. Kunkel, Viscous Effects in Highly Ionized Rotating Plasmas, in Proceedings of the Fourth International Conference on Ionization Phenomena in Gases, Uppsala, 1959 (North-Holland Publishing Company, Amsterdam, 1960), Vol. II, p. 1171.
18. C. C. Chang and T. S. Lundgren, *Phys. Fluids* 2, 627 (1959).
19. T. G. Cowling, Magnetohydrodynamics (Interscience Publishers, Inc., New York, 1957) p. 17.
20. R. C. Lock, *Proc. Roy. Soc. (London)* A233, 105 (1955).
21. J. Bergström, S. Holmberg and B. Lehnert, *Nucl. Fusion*, 1962 Supplement, Part 2.
22. K. Halbach, W. R. Baker, and R. W. Layman, *Phys. Fluids* (to be published).

23. Even in experiments with partially ionized rotating plasmas, axially-nonsymmetric patterns are to be expected (H. Alfvén, private communication).
24. C. C. Lin, The Theory of Hydrodynamic Stability (Cambridge University Press, 1955), Chapter 3.
25. J. T. Stuart, Proc. Roy. Soc. (London) A221, 189 (1954).
26. S. Chandrasekhar, Hydrodynamic and Hydromagnetic Stability (Clarendon Press, Oxford, 1961), Chapter IX.
27. S. Chandrasekhar, *ibid.* p. 419.
28. S. Chandrasekhar, *ibid.* p. 389.

FIGURE LEGENDS

Fig. 1. Homopolar II experiment (schematic) showing collector probes at the outer electrode.

Fig. 2. Homopolar III experiment.

Fig. 3. Oscilloscope traces from Homopolar III experiment.

(a) Current-button response, 1 A/cm; 50 μ sec/cm;

(b) Voltage, 3 kV/cm; 50 μ sec/cm;

(c) Total current, 40 kA/cm; 50 μ sec/cm;

(d) and (e) Current-button responses at a speed of 10 μ sec/cm starting at 60 μ sec after breakdown.

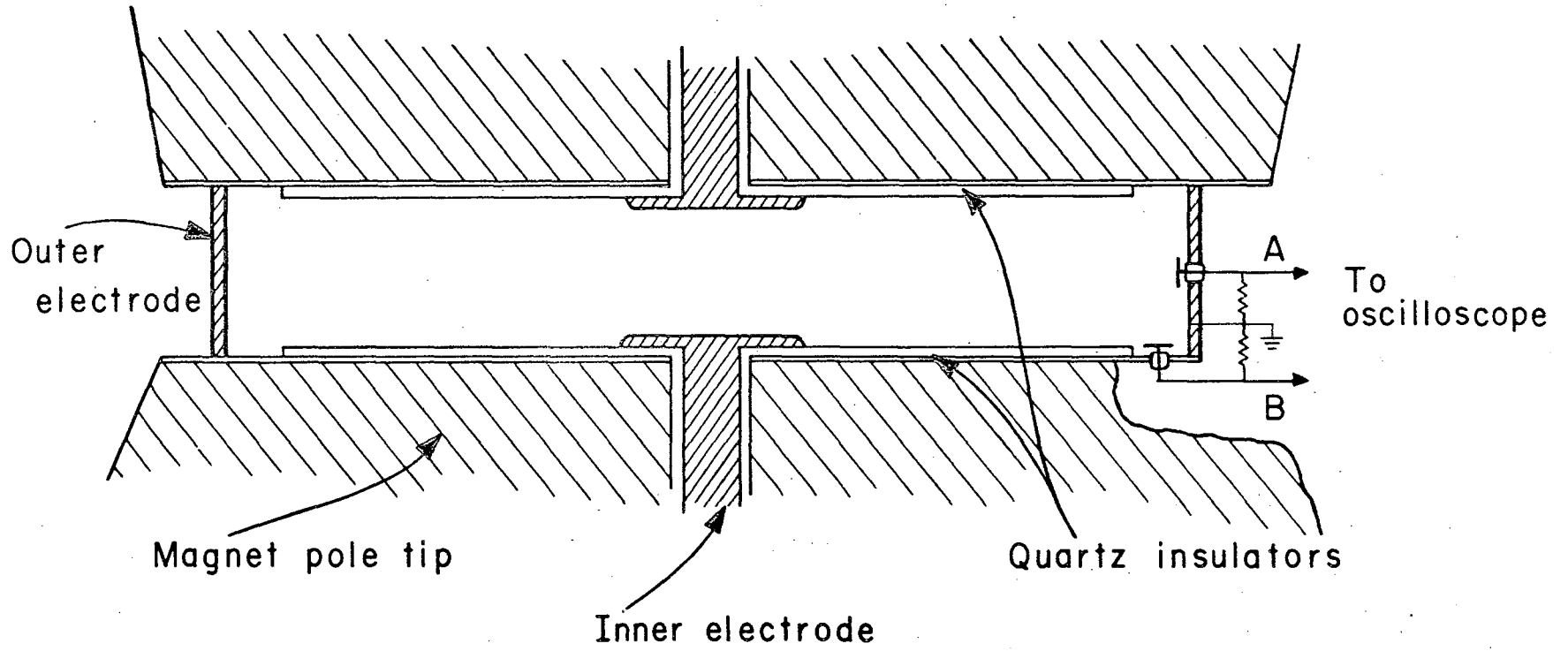

MU-27962

Fig. 1

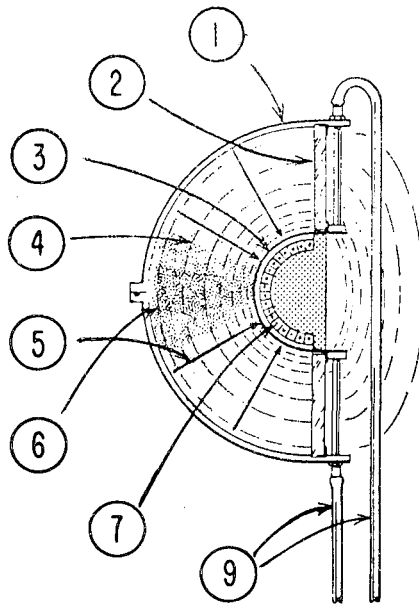
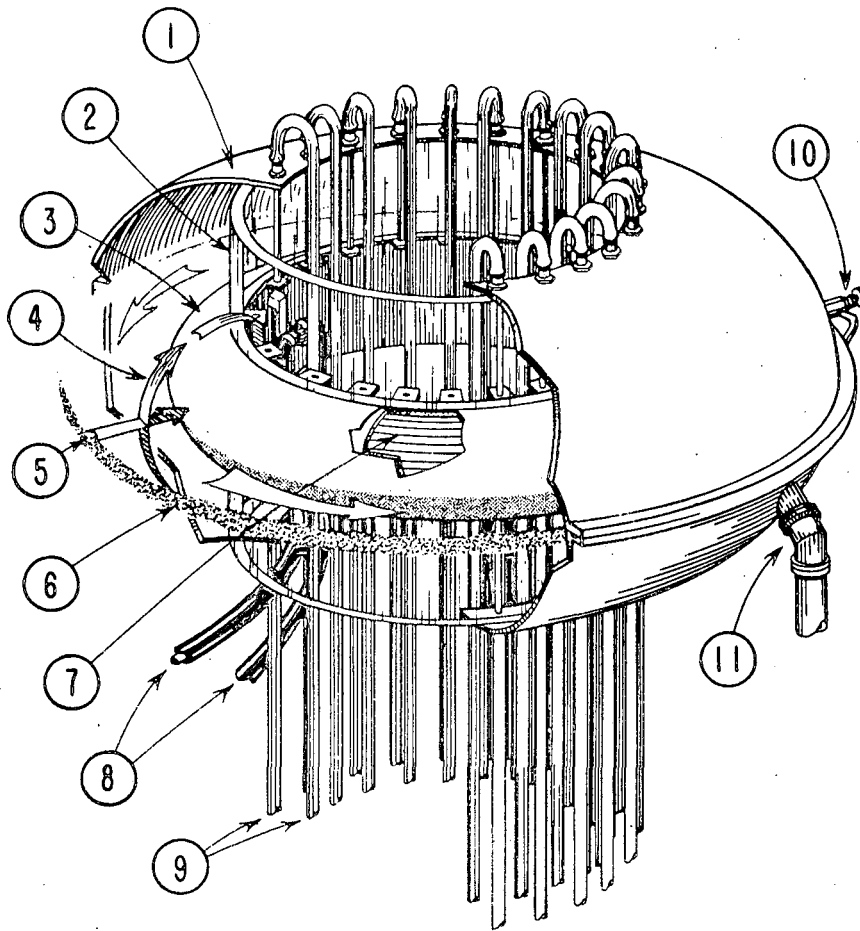

Fig. 2

MUB-192

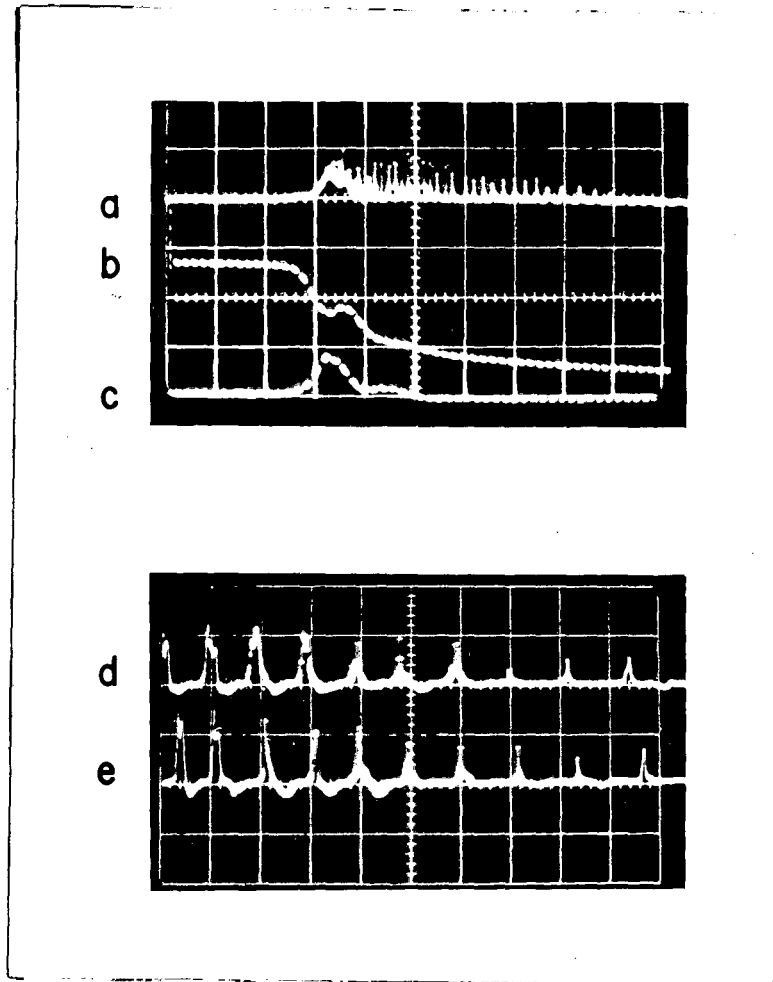

Fig. 3

This report was prepared as an account of Government sponsored work. Neither the United States, nor the Commission, nor any person acting on behalf of the Commission:

- A. Makes any warranty or representation, expressed or implied, with respect to the accuracy, completeness, or usefulness of the information contained in this report, or that the use of any information, apparatus, method, or process disclosed in this report may not infringe privately owned rights; or
- B. Assumes any liabilities with respect to the use of, or for damages resulting from the use of any information, apparatus, method, or process disclosed in this report.

As used in the above, "person acting on behalf of the Commission" includes any employee or contractor of the Commission, or employee of such contractor, to the extent that such employee or contractor of the Commission, or employee of such contractor prepares, disseminates, or provides access to, any information pursuant to his employment or contract with the Commission, or his employment with such contractor.

