

UC Berkeley

Working Papers

Title

Video-based Vehicle Signature Analysis and Tracking System Phase 2: Algorithm Development and Preliminary Testing

Permalink

<https://escholarship.org/uc/item/8nd8g5sj>

Author

MacCarley, C. Arthur

Publication Date

2001-02-01

CALIFORNIA PATH PROGRAM
INSTITUTE OF TRANSPORTATION STUDIES
UNIVERSITY OF CALIFORNIA, BERKELEY

Video-based Vehicle Signature Analysis and Tracking System Phase 2: Algorithm Development and Preliminary Testing

C. Arthur MacCarley

California Polytechnic State University, San Luis Obispo

**California PATH Working Paper
UCB-ITS-PWP-2001-10**

This work was performed as part of the California PATH Program of the University of California, in cooperation with the State of California Business, Transportation, and Housing Agency, Department of Transportation; and the United States Department Transportation, Federal Highway Administration.

The contents of this report reflect the views of the authors who are responsible for the facts and the accuracy of the data presented herein. The contents do not necessarily reflect the official views or policies of the State of California. This report does not constitute a standard, specification, or regulation.

Report for MOU 350

February 2001

ISSN 1055-1417

PATH

California Partners for Advanced Transit and Highways



V²SAT

Final Report

Video-based Vehicle Signature Analysis and Tracking System

Phase 2:
Algorithm
Development and
Preliminary
Testing

Caltrans/PATH
MOU 350



Prepared for PATH/Berkeley and the California Department of Transportation
by the Transportation Electronics Laboratory, Dept. of Electrical Engineering
California Polytechnic State University, San Luis Obispo, California, and
Loragen Corp., Advanced Technology Group, San Luis Obispo, California
Caltrans/PATH MOU 350, Cal Poly Foundation Project No. 5925

Document No. TEL.5925.00.F June 25, 2000 (Draft), December 31, 2000 (Final)

Table of Contents

Executive Summary	1
Keywords	3
Disclaimer	4
Acknowledgements	4
Objectives	5
Detection Requirements	6
V ² SAT System Architecture	7
Vehicle Signature Analysis	11
Field Data Acquisition	15
Review of Phase 1 Results on Uniqueness and Repeatability of the VSV	20
Relative Value of Vehicle Color and Reasonable Time of Arrival Window	28
Image Sensor Performance and Selection Considerations	29
V2SAT Intrinsic Performance Analysis – Travel Time Estimation	31
Phase 2 Computer Vision Algorithm Development	34
Summary of V2SAT Phase 2 Algorithm Development (Task A)	36
The VSV Generation Program (v2sat.exe) Running on Each Detection Computer	38
The Vector Correlation Program (Correlation Engine)	45
V2SAT System Test & Verification Procedures	48
Field Test Results	52
Field Test Data 9-2-99 Late Morning	52
Field Test Data 9-28-99 Noon	53
Field Test Data 10-5-99 Early Afternoon	54
Composite Test Results	55
Observations Related to System Errors	56
Observed reasons for false matches:	56
Observed reasons for failures to match:	56
System Limitations	56
Problems Related to Limited Dynamic Range of CCD Video Camera	57
General Conclusions and Future Direction	59
References	60
Appendix	61
1. Main Report (CD 1)	61
2. V2SAT Phase 2 System Field Test Setup Procedures / Checklist (CD 1)	61
3. V2SAT program files (CD 1)	61
4. Data and Correlation Results Files from Field Tests of Experimental System (CD 1-5)	61

Executive Summary

This report describes the results of the PATH/Caltrans-funded project *Video-Base Signature Analysis and Tracking (V²SAT) System, Phase 2 Algorithm Development and Preliminary Testing*. The V²SAT System was conceived in 1995 by Loragen Systems, of San Luis Obispo, California, as a means for non-intrusively tracking individual vehicles on freeways for data collection purposes. The concept involves the use of computer vision methods to make simple optical measurements on digitized real-time images of each vehicle on the freeway. A conventional color video camera serves as the primary sensor. Detection modules are placed directly above traffic lanes on an overcrossing or similar support structure, with one detector for each lane. For each passing vehicle, a numeric Video Signature Vector (VSV) is generated and transmitted by the detection module to a central correlation computer, via a low-power wireless network. The correlation computer continuously receives VSV's asynchronously transmitted by all detection modules, and attempts to match VSV's to re-identify vehicles at each detectorized site, in order to determine the progress of each vehicle through the freeway network.

If sufficiently accurate and cost-effective, V²SAT is potentially useful as a means for tracking all individual vehicles in freeway traffic for such purposes as traffic flow model validation, generation of origin-destination data, travel time estimation, validation of local modal emission models, and possible applications in law enforcement. Potential advantages are low cost in widespread deployment, simplicity and reliability of detection, minimal bandwidth and storage requirements for transmission of the signature vector, and reasonable identification ability without violation of privacy rights.

Phase 1 of this multi-phase study involved field data collection and laboratory data reduction for the purpose of validating the operational concept of the method. Phase 1 was restricted to an assessment of the detectability and uniqueness of the video-based Vehicle Signature Vector (VSV). Two identical portable field data acquisition systems were designed to permit the synchronized recording of video images of vehicles flowing beneath two successive freeway overcrossings. These were used at three pairs of test sites along US Highway 101 in the Central Coast area of California. Each pair of sites consisted of two accessible overcrossings separated by approximately 0.5 miles. Field tests were conducted over a range of traffic conditions and times of day. Time-synchronized video-tapes from both overcrossings and each test site were studied in the laboratory on a frame-by-frame basis.

The S-VHS video tapes from each pair of sites were post-processed and analyzed in the laboratory on a frame-by-frame basis using video editing equipment and a reference video monitor. For each vehicle recorded by each camera, manual screen measurements were made of dimensions between points of optical demarcation (such as the windshield-to-hood transition) along a virtual centerline through each vehicle. In addition, a PC-based computer vision program was used to post-process the video images to provide an objective characterization of the predominant color for each vehicle. From this collection of measurements for each observed vehicle, a VSV was manually generated. Time-indexed lists of the VSVs for each vehicle, and all possible pair-wise comparisons of VSVs for each of four test conditions were created in Microsoft EXCEL spreadsheets.

Data sets were segregated by four test conditions, corresponding to four ambient lighting conditions: overhead sun (mid-day), 45 degree sun (afternoon), reduced light (dusk), and low light (night). For each test condition, VSV's were compared for each vehicle at the first site with every vehicle at the second site. A correlation error factor was developed based upon a normalized sum of the absolute difference between the vector components from each site. Used for comparison purposes, a "match" is detected if the correlation error for the pairing is below some fixed threshold, which was generally set to be inversely proportional to the intensity of the ambient illumination for the test condition. Results were accumulated on the accuracy of matching the same vehicle at consecutive sites (self correlation) and the possibility of falsely matching dissimilar vehicles at consecutive sites (false correlation).

Self-correlation was assessed by comparing the VSV of each vehicle observed at the first overcrossing with its VSV at the second overcrossing. False-correlation was assessed by comparing the VSV for each

vehicle at the first overcrossing with the VSV of all other vehicles observed within the data collection period at the second overcrossing.

Correct self correlation matches were observed for 97.27% of all vehicles at mid-day, 98.89% in the afternoon, and 95.15% at dusk. False correlation matches occurred for 0.22% of all possible vehicle pairings at mid-day, 1.66% in the afternoon, and 2.02% at dusk. For daylight conditions, we also assessed the relative value of color as a VSV component, and the relative value of restricting vehicle comparisons at successive sites to a "reasonable time of arrival window". The additional color information was found to increase correct matches from 98.3% to 99.0% and reduce false matches from 5.4% to 0.3%. The restriction to "reasonable time of arrival window" was found to add almost no additional accuracy beyond the addition of color information for either metric, although we do not consider the sample size in this test large enough to be statistically sound. It appeared that the use of an adaptive correlation threshold, keyed to average illumination level, improved accuracy with respect to both metrics.

Uniqueness and detectability results reported in Phase 1 were considered somewhat pessimistic, due to the possibility of additional errors introduced during data reduction, which involved manual measurements of VSV components - vehicle dimensions from the video CRT display, and color intensity and hue via computer image processing. At low scene illumination levels such as those encountered at night, the VSV was found to be difficult and sometimes impossible to measure, with accuracy falling to 75.49% correct matches and 27.05% false matches (without arrival window).

General conclusions from Phase 1 were that the VSV is a reliable and repeatable means for the characterization and successive re-identification of vehicles under daylight and transitional illumination conditions. The VSV is unusable if the illumination level is inadequate to produce an acceptable video image. Overall, we conclude that the V²SAT method is valid for the tracking of individual vehicles through a highway network, but only during conditions of adequate ambient lighting, or with either supplemental illumination or the use of improved dynamic range video cameras.

Phase 2a involved the development of an experimental platform for machine vision-based detection of the vehicle characterization vector components. This consisted of a PC-based real-time image processing system and custom designed software, and related image acquisition and storage equipment. This laboratory apparatus permitted the experimental mechanization, validation and refinement of the signal processing techniques and algorithms described herein for the automated detection and correlation of vehicle characterization vectors. Algorithm development, preliminary testing and refinement utilized videotaped data collected during Phase 1 where possible, but additional field data collection was necessary.

Development work included determination of system hardware requirements and ultimately a specification for the field prototype, based upon development work using laboratory-based apparatus. We developed and refined experimental PC-based image processing software for detection of the VSV metrics in real time from the digitized video data stream. We also implemented and tested various specifications for the vector packet and transmission protocol. Lessons learned and data indicative of the accuracy of the experimental software/hardware for extraction of VSV components were utilized in Phase 2b.

Phase 2b involved the development of field prototype hardware and software based upon the experimental platform developed in Phase 2a. Four experimental automated detection modules were designed, fabricated, programmed, debugged, calibrated and laboratory tested by Loragen Systems. The availability of these units made possible concurrent detection and tracking across all lanes at two consecutive sites on a four-lane freeway. A single correlation engine (server) was developed to receive and correlate real-time data from the field detection modules. These units were field tested under actual freeway conditions by the Cal Poly Transportation Electronics Laboratory to assess accuracy and robustness in detection and de-identification of individual vehicles.

Test sites were overcrossings, with detector placements vertical downlooking at heights of 24 to 28 feet above the road surface. Communications between units at each site and the correlation server were

wireless modems, utilizing the Metricom commercial wireless network system as a means for Internet-based data transfer. Data was acquired and correlated with time of observation by each site computer. Real-time vector correlation was used to match the same vehicle at successive sites, avoiding false matches.

Statistical analysis was later performed to assess the accuracy of correlation results generated by the V2SAT network. Field tests were performed over a range of traffic, illumination, and atmospheric conditions. Time-average and count-average percent errors were reported for each test condition. Detection errors will generally fall into two classes:

(1) *No match*. Due to ambiguous vector. Same vehicle generates vectors at successive sites that differ excessively in component-weighted average. Deviation sufficient to not trigger re-identification at second site.

(2) *Incorrect match*. Vector at second site is sufficiently well correlated with vector from a different vehicle at first site to trigger false re-identification.

With an accumulation of data, it was possible to assess an optimum relative weighting of individual components of the VSV for minimization of errors of both types. The optimum vector weighting considers both the basic information content in the video image sequence, and the machine-vision limitations of the system, under the expected range of operational conditions.

While originally proposed for Phase 3 and not included in Phase 2 deliverables, we incorporated the deployment of the wireless network hardware and software components for communications between overcrossing transponders and a central network tracking computer, for vehicle flow tracking and traffic flow model validation. Among the specific accomplishments were the design and mechanization of the detection module communications software and wireless-modem interface, and the network hardware and software components of for the correlation engine/server.

Field test were performed using two lanes at each of two detection sites separated by approximately 0.34 mile. Results generated by the system in real time were compared off-line against manually verified results from video tapes. Self-correlation accuracy, or the ability to correctly re-identify vehicles at successive sites, was 93.6%. False-correlation errors, or the tendency of the system to incorrectly match different vehicles at successive sites, was 0.0116%. Finally, the basic ability of the system to generate valid vectors for each car was assessed. This is referred to as presence detection accuracy, and was found to be 97.0% over all vehicles, including some for which a reasonable VSV cannot be generated such as a motorcycle or large tandem truck.

It is planned in **Phase 3** to focus on the deployment of a prototype field-hardened system complete with large-area network vehicle tracking software, including algorithms and user interface, for automated network-wide vehicle flow database generation, utilizing the vectors transmitted by each detection module in the study area. In-service field testing of the complete system over a larger freeway study area will also be performed.

This report addresses primarily Phase 2, but reviews as necessary prior developments under Phase 1. For complete details on Phase 1 work, reference is made to the previous PATH report "Video Vehicle Signature Analysis and Tracking, Phase 1: Concept Verification and Preliminary Testing", published by the Cal Poly Transportation Electronics Laboratory and PATH, U.C. Berkeley, 1998.

Keywords

Video, detection, sensing, sensor, computer vision, image processing, traffic monitoring, vehicle tracking, transportation electronics, video signature vector, video signature analysis, advanced traffic management, surveillance, monitoring, correlation, ensemble averaging, network tracking, object identification.

Disclaimer

The statements and conclusions of this report are those of the authors, and not necessarily those of the State of California or the California Department of Transportation. The results described in this document are based solely upon tests conducted by the Cal Poly Transportation Electronics Laboratory, with the support of the California Department of Transportation and California PATH. This report does not constitute a standard, regulation or specification. The mention of commercial products, their sources, or their use in connection with materials reported herein is not to be construed as an actual or implied endorsement of such products.

Acknowledgements

The author gratefully acknowledges the support of the California PATH / U.C. Berkeley and the California Department of Transportation. In particular, I wish to acknowledge the guidance and direction of the contract monitor, Robert Tam of PATH / U.C. Berkeley.

This report was written by the staff of the Cal Poly Transportation Electronics Laboratory, in particular, Prof. C. A. MacCarley (lab director) and Michael Hawes (project director). Documentation of program operation was written by Brian Hemme of Loragen Corp. Graduate research assistants Timothy Ferris and Chad Kecy assisted with field data acquisition. All data reduction and results generation were performed by Prof. Hawes, and grad assistants Ferris and Kecy. The V2SAT system and algorithms were designed and programmed by the staff of Loragen Corp. of San Luis Obispo, California. Major contributors were C. A. MacCarley (system design), Brian Hemme (senior programmer) and Kyle Wayman (student programmer). Technical advice and review comments were provided by Joseph Palen of the California Department of Transportation, New Technology Division.

Background

The V²SAT project was motivated by the California Department of Transportation Division of New Technology's interest in the development of a vehicle discrimination and network tracking system to support the study of vehicle flow patterns on freeways and arterials. Systems meeting the Caltrans' specifications must provide (1) reliable delineation and re-identification of a wide variety of vehicles under all possible traffic flow, environmental, and illumination conditions, (2) operate at low power consumption to permit autonomous battery-only or photovoltaic operation, and (3) be of low-to-moderate cost.

In response to this request, and in conformance with the stated criteria, a system configured as a network of vision-based detection, correlation, and wireless communication modules was designed by Loragen Systems of San Luis Obispo, California, and proposed for preliminary testing in partnership with PATH and Cal Poly, San Luis Obispo. The **Video-based Vehicle Signature Analysis and Tracking (V²SAT)** system is intended to possibly meet all stated criteria. V²SAT utilizes low-cost NTSC (National Television Systems Committee) color video cameras as its primary sensors. Individual sensor modules are mounted on a freeway overcrossing, positioned above each lane. The video image signal is processed to generate, for each vehicle passing beneath the detector, a simple **Vehicle Signature Vector (VSV)**, consisting of a finite number of metrics extracted from the vehicle optical signature. Each detection module is to (in the final version) be self-contained, powered by batteries with the option for photovoltaic power for continuous operation.

The required network communications system has evolved with recent improvements in commercially-available wireless networking technology. In its updated configuration, the individual detection modules communicate on a vector-by-vector basis with a proximate commercial wireless network repeater via standard Internet-compatible protocols. VSV's are transmitted over this network to a central network correlation engine / server. A real-time program and user interface runs on the correlation engine which re-identifies and maintains records of vehicles which appear at successive detection sites on the roadway, by comparing VSV's transmitted by all deployed modules.

The overall project is divided into three phases: Phase 1 involved preliminary work to test the accuracy, reliability and robustness of the basic phenomena upon which the detection method is based. Phase 2 involves the development of experimental hardware and software for automated detection, as described in detail herein. Although not included as deliverables in the Phase 2 proposal, accomplishments also included the development of the wireless network components for telemetry between individual lane detectors and a local site transponders, and hardware and software components for telephone/modem communications between overcrossing transponders and the central correlation computer. Efficient correlation algorithms for tracking large numbers of vehicles were also developed, and a graphical interface and traffic flow display module was created. In Phase 3, compact field-hardened detection modules will be designed, refined, fabricated, deployed and tested. Direct links to adaptive traffic flow simulation models will be studied to calibrate, validate, and extend the utility of these models.

Objectives

The objective of Phase 2, as described herein, was the experimental development and deployment of a small network of computer vision systems designed to mechanize, refine and test V²SAT detection algorithms. Based upon recorded video images, optimal computer vision algorithms were developed and refined for delineation and discrimination of vehicles on freeways. Four field detection units and one central correlation server were developed and field tested with live video from actual traffic from several freeway overcrossings, using video cameras mounted approximately 0.5 meters out from the side of the overcrossing deck, facing downward. Tests were done at pairs of consecutive overcrossings, with video image sequences stored for each vehicle passing in the lane under the camera at each site. Lighting conditions and traffic conditions varied to the normal extent over the course of a typical commuting day, and night conditions were also acquired to allow assessment of the detection method under low-illumination conditions. Wireless communication hardware and software were developed to transmit real-

time VSV data to the centrally located correlation server. Correlation and false correlation accuracy results were compiled over data sets of several hundred vehicles each.

If proven accurate and cost-effective, V²SAT is potentially useful as a means for tracking the progress of individual vehicles in freeway traffic for such purposes as traffic flow model validation, generation of origin-destination data, travel time estimation, validation of local modal-based emission models, and possible applications in law enforcement. Potential advantages are low cost in widespread deployment, simplicity and reliability of detection, minimal bandwidth and storage requirements for transmission of the signature vector, and reasonable identification ability without violation of privacy rights.

Detection Requirements

The need for accurate information on individual vehicle travel characteristics on freeways is well established. This data is essential for support of transportation resources and facilities planning, traffic management, and roadway engineering. In recent years, the need for this data has become more pronounced, with the advent of fully integrated network-wide traffic management strategies.

In addition to and in support of these strategies, a wide range of computer simulation models have been developed for the characterization and prediction of traffic flow patterns. These generally fall into two classes: *macroscopic* models, in which vehicle flow is treated as a continuum much like compressible fluid flow, and *microscopic* models, in which individual vehicle behavior is simulated [3]. This latter class of models, while more sophisticated and more useful in transportation engineering, is much more difficult to validate since data including individual vehicle lane and turning movements, traveler origin-destinations, and diversion behaviors must be recorded over extended time periods.

Prior detection technology does not support automated data collection at reasonable cost. Existing data collection techniques are typically manual or semi-automated in nature., e.g., extrapolation from loop detector data, human observation, floating car studies, and traveler surveys. Accuracy and adequate sample size are known weaknesses, and cost per data unit is a key obstacle. Analog inductive loop signatures are known to provide only crude signatures of vehicles, which are variable between detection sites. Existing vision-based detection means, such as computer-vision-based license plate readers, have been generally unsuccessful and are considered non-cost-effective. Related legal issues such as individual privacy rights and access to collected license plate based travel data have yet to be definitively tested in legal forums. Intrusive monitoring means, such as characteristic vehicle tags or markers have been generally considered unsuitable since they require the consent and cooperation of a large number of routine travelers in the test network area. Issues associated with this class of detection have been recognized in the context of several detection methods [8,9,10].

This void in technology is potentially addressed by the V²SAT system.s report. The general detection system requirements were established by Caltrans New Technology Division [9] in 1996, and are repeated below:

Detectors shall be mounted on freeway overcrossings or similar rigid structures above traffic lanes on freeways.

Detectors shall be self-powered and fully self-contained.

Ability to uniquely identify each vehicle passing beneath detector, characterizing the vehicle with a simple information vector, which is communicated via wireless medium to proximate information processing hub.

System shall have capability to re-identify detected vehicles as they progress through detectorized segments of freeway network.

Detection and re-identification shall attempt to be reliable and robust to reasonably anticipated operating conditions changes and system disturbances.

Detection means shall be safe and non-intrusive.

System shall be low cost on per-site basis.

Detection elements shall be easily installed without disruption to traffic flow.

Detection elements shall be suitable for temporary installation at freeway overcrossings.

System shall provide for ease of integration into network-wide traffic data collection system.

The unique function of this system is the detection in real time of a reasonably unique video-derived *Vehicle Signature Vector (VSV)* for every vehicle, which adequately characterizes the vehicle with an adequate amount of information to allow re-identification of the vehicle at subsequent detector sites. Successive re-identification of each vehicle may be used to track the progress of vehicles through the study area. The *uniqueness* and *redetectability* of the VSV vector must be balanced against cost, practicality and deployability factors for the overall system. Additional traffic flow metrics of possible value in traffic management may also be generated and collected by the system: individual or traffic-averaged vehicle speed (both instantaneous or segment averaged), accumulated or time averaged traffic counts, traffic density, and vehicle class (passenger auto, light truck, heavy truck, tandem, triple, etc.)

Our objective under Phase 1 was to assess the basic accuracy of the V²SAT operational concept under a range of operational conditions, and to refine the signature vector based upon lessons learned in the course of data collection and reduction.

V²SAT System Architecture

The V²SAT System is intended to serve as a low-cost solution for the delineation and re-identification of vehicles along a freeway network. The system utilizes a low-cost EIA-RS170/NTSC video camera as a sensor to provide scanned optical information adequate for the development of a unique but simple signature vector for each vehicle. Testing was conducted with the assumption of one detector per lane, although this may or may not represent the ultimate system deployment. The video signal is processed to generate a VSV for each vehicle passing beneath the detector. Each detection module is intended to be self-contained, powered by batteries with the option for photovoltaic power for continuous operation. Individual modules communicate in burst mode on a vector-by-vector basis with a proximate site repeater located in a traffic controller cabinet. Information will be relayed to a central vector correlation computer, which identifies individual vehicles via their signatures and (possibly) feasible arrival times at successive detectorized sites along the freeway network. The central tracking system should be capable of utilizing the individual vehicle flow information in a number of ways, including validation and adaptation of predictive traffic flow models, real-time graphical display of traffic flow patterns, and real-time reporting of traffic incidents based upon disruption of logical vehicle travel patterns.

In this section, we will discuss the sensor, the detection/discrimination procedure, and the content of the information vector.

As originally proposed, the key components of the V²SAT architecture are described in Figure 1. The overall system is comprised of three elements: (1) **detection modules** located on a physical structure (such as an overcrossing) directly above each traffic lane, (2) a local **transponder / repeater**, one per detectorized site, that receives low-power UHF/spread spectrum bursts from as many as ten proximate detector modules, and retransmits the received information in raw form via a conventional telephone modem to (3) the **network hub**, which receives the data stream from all detectors and correlates the vector data to identify the progression of each particular vehicle signature through the freeway study area. In the course of Phase 2 work, the need for the local transponder / repeater were replaced by the use of

wireless modems and communications via a new commercial wireless network service provider which operates over much of Caltrans' right-of-way in California.

The component plan form and power requirements for the detection module are expected to make it suitable for self-contained operation and for extended use in the field. With a maximum expected continuous power draw of under 3 Watts, power requirements could be met by an internal 12 volt gel cell battery. An optional small photovoltaic array¹, mounted on the detector module, is expected to provide adequate power for continuous unattended operation.

Detected attributes for each vehicle are derived from vehicle width and optical profile measurements along the vehicle centerline, and primary color components. This information is then incorporated into the video-derived Vehicle Signature Vector (VSV). The 112-bit (14-byte) VSV packet or is then transmitted as a packet of information to the network hub, via the site transponder/repeater.

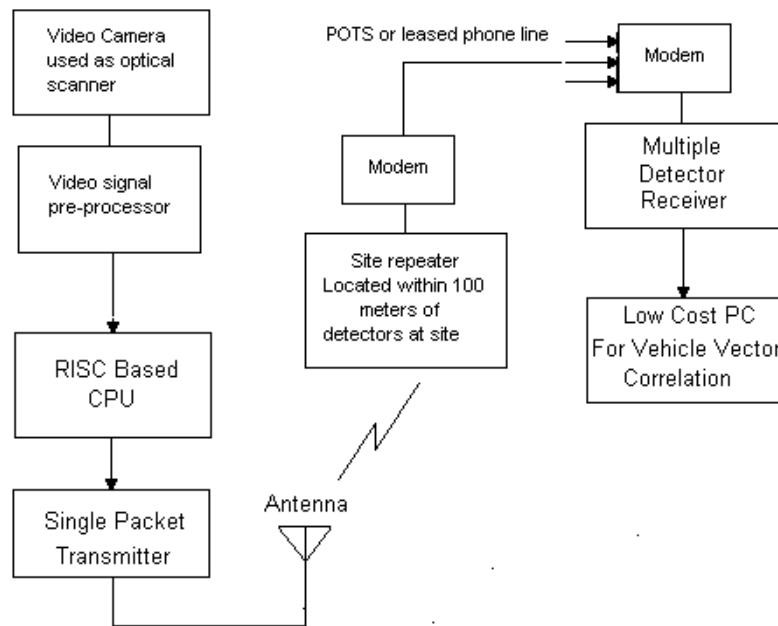

Figure 1. Block diagram of key V2SAT System Components as Originally Proposed.

¹ 0.25 m² surface area @ 40 W/m² average power over 10 hour insolation period. Photovoltaic array provides minimum of 100 WHr per day. Average power draw of detector over 24 hour period is 60 WHr.

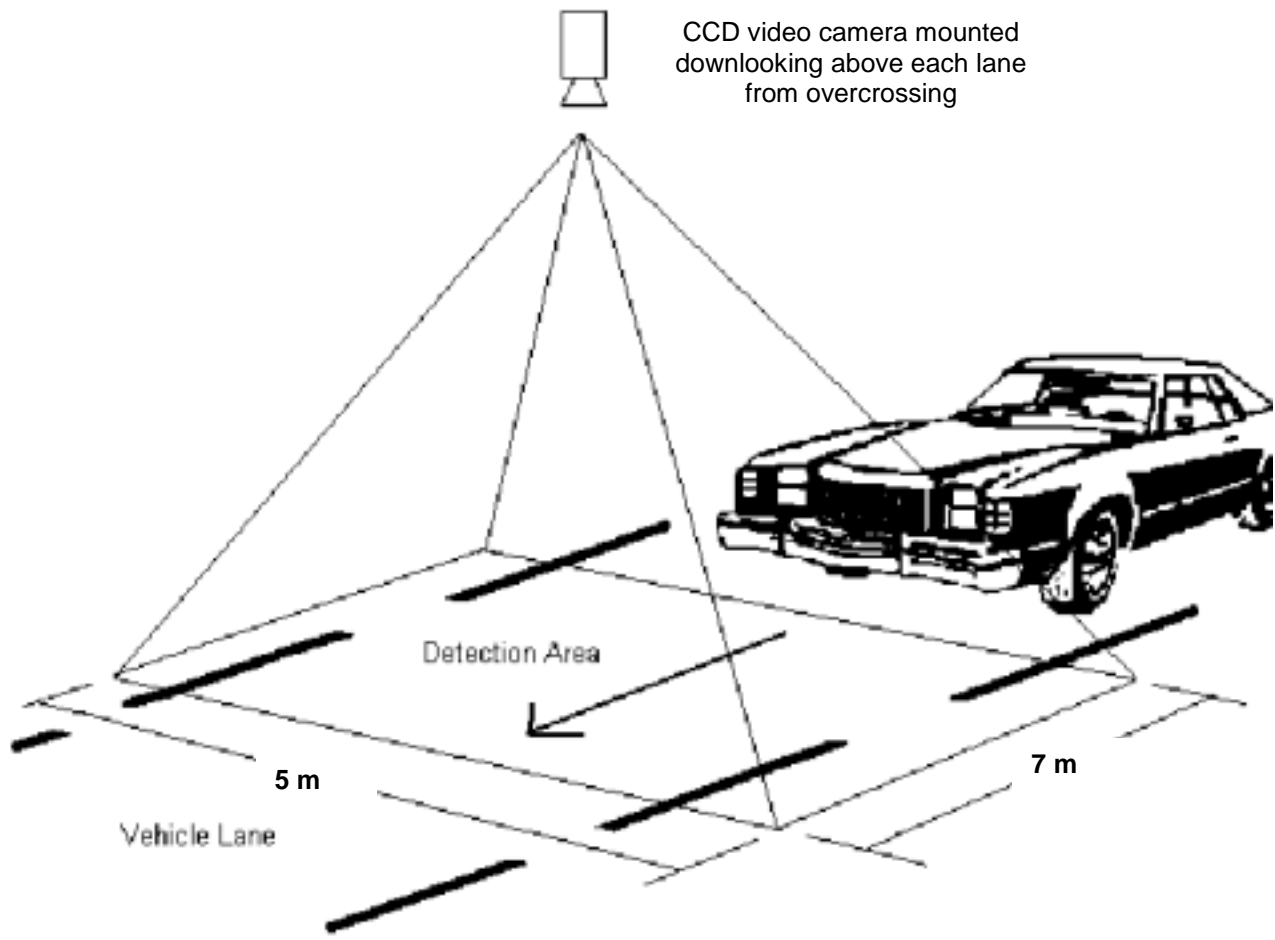

Figure 2. V²SAT Detector Camera Positioning on Overcrossing.

Santa Rosa St. (Hwy 1)
Overcrossing



California St. (Cal Poly)
Overcrossing



Metricom Wireless
Network (19.2 kbps)

Figure 3. V²SAT Hardware
Components - Field Test Version.

Internet Node



Server/Correlation Engine
(Laboratory or TMC)

Vehicle Signature Analysis

In the V²SAT system, the VSV is generated by processing successive video fields with several elemental operations:

- Accumulation of a time-average background image via a first-order IIR filter operating on individual pixels.
- Subtraction of image from accumulated background along selected scan lines to identify object edges and points of contrast.
- Field-to-field ensemble-averaging of centerline traces from successive images to distinguish true object features from image artifacts and transient shadows.
- Intensity profile measurements along the true vehicle centerline, and maximum vehicle width.
- Trigonometric correction of image coordinates to scene coordinates, including camera height and angle compensation, to yield normalized measurements.
- Average primary color hue and saturation measurement from parsed RGB values along the vehicle centerline.

If the camera is oriented perpendicular to the road surface, directly above the lane under detection, only the height of the detector above the traffic lane is needed in the system setup in order to derive physical measurements from image measurements. A tall vehicle will still appear longer than a low one, but site-to-site differences can be normalized with respect to camera height. A simple correction factor, based upon the detector height, is used in the proof of concept work reported herein, to assure correct dimensional correlation between detector sites. It is recognized that for less-than-ideal camera placements, including positions not aligned with the vehicle lane a two-dimensional angular correction will be necessary to assure that image-based measurements are accurately mapped to actual scene measurements.

The algorithm determines the true (image) center line of the vehicle, even if it is significantly off-axis with the lane, such as during a lane-change transition. The algorithm then extracts metrics from the optical signature of the vehicle, to the maximum extent possible for each vehicle: physical lengths between key points of abrupt intensity and chromatic change along the vehicle centerline, which typically correspond to the distance from bumper to windshield (L1), distance from bumper to rear windshield (L3) and two optional distance metrics (L2) and (L4). These measurements are illustrated in Figure 4.

Background subtraction and rejection of shadow artifacts is accomplished by using a combination of the color hue (H) and intensity (I) components extracted from the composite NTSC video signal by simple processing of 24-bit RGB pixel values² produced by a color frame grabber. In NTSC composite encoding of color video, hue can be measured as the angle of the color “vector” in degrees, and saturation measured as the color vector magnitude. The inclusion of color measurements in the VSV are considered optional, since they are not expected to be available under low-light conditions. The ideal components of the VSV are shown below. Each is encoded as an 8-bit integer, with the exception of the site code S and time code t, which occupy two bytes each. The overall vector length is 14-bytes (112 bits). Not all components may be known for a particular vehicle; the lack of a component in the vector is encoded as a zero value.

$$x_{i,t} = (L0, L1, L2, L3, L4, W, C1, C2, V, N, S, t) .$$

² RGB = Red-Green-Blue color signal decomposition. HSI = Hue-Saturation-Intensity color signal decomposition. The HSI decomposition is derived from RGB by simple trigonometric calculations.

where:

L0 = Total vehicle length along vehicle centerline.

L1 = Length from front of vehicle to first optical feature, typically the bottom edge of the windshield.

L2 = Length from front of vehicle to second optical feature, typically the top edge of the windshield.

L3 = Length from front of vehicle to third optical feature, typically the top of the rear window on a conventional sedan.

L4 = Length from front of vehicle to fourth optical feature, typically the bottom edge of the rear window on a conventional sedan.

W = Vehicle body extremal width, exclusive of mirrors or other small side projections.

C1 = Primary color intensity component, measured as a normalized magnitude.

C2 = Primary color hue component, measured in degrees.

V = Vehicle velocity.

N = Lane number at site.

S = Site code number.

t = Absolute time code, resolution to one video field interval, 1/60 second.

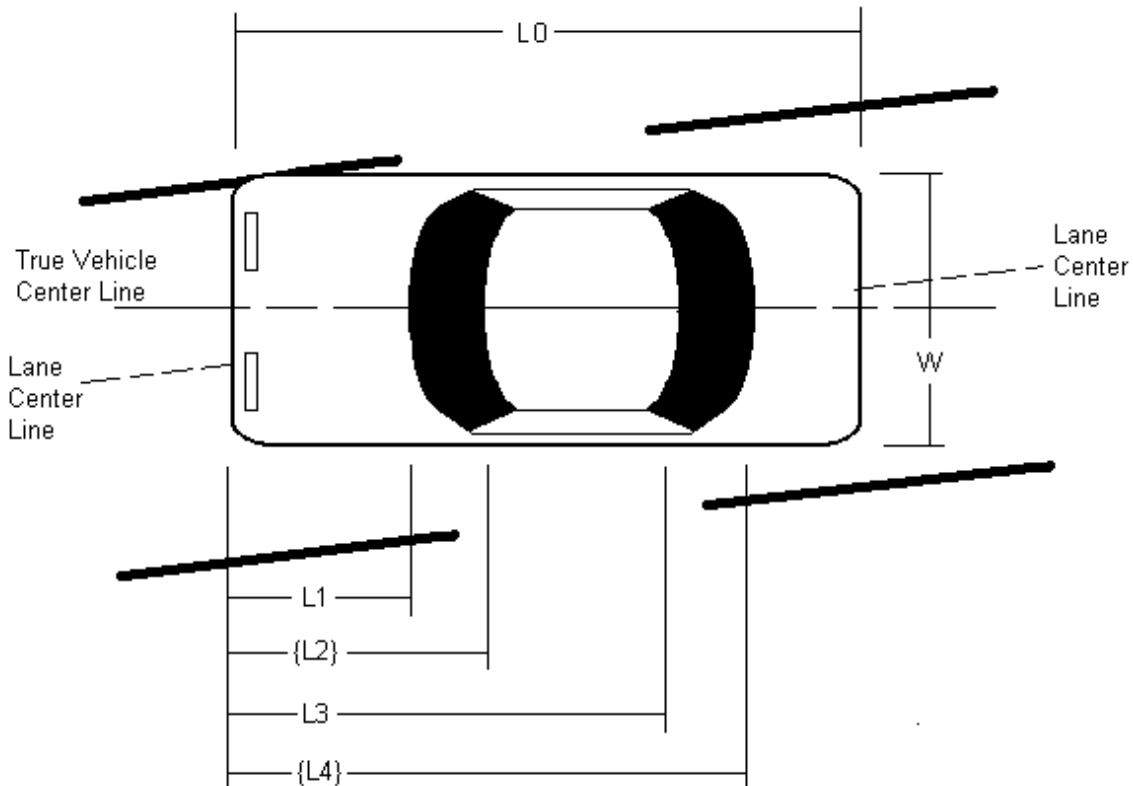

Figure 4: Diagram of the proposed vehicle metrics based upon true vehicle centerline.

Overlaid upon a digitized video frame of typical vehicle, these measurements are shown in Figure 5.

In general, the height and placement geometry of the detection camera must be known and the computer vision algorithm must map image-based dimensions to physical (scene-based) dimensions, a process involving trigonometric correction in two dimensions. For narrow angles of view and camera placements directly over and perpendicular to the center of a lane, angular aberration is minimized, such that reasonably accurate measurements can be generated and matched between sites by compensating only

for the camera height above the road surface. This was the camera placement we used exclusively for Phase 1 validation studies. If the detector is placed 25 feet above the road surface, the detection area, with 8 mm lens and 1/3 inch imaging element, is about 15 feet wide x 20 feet long, along the roadway axis. This is based upon the US standard video aspect ratio of 4:3 and 90% scanned line utilization [1].

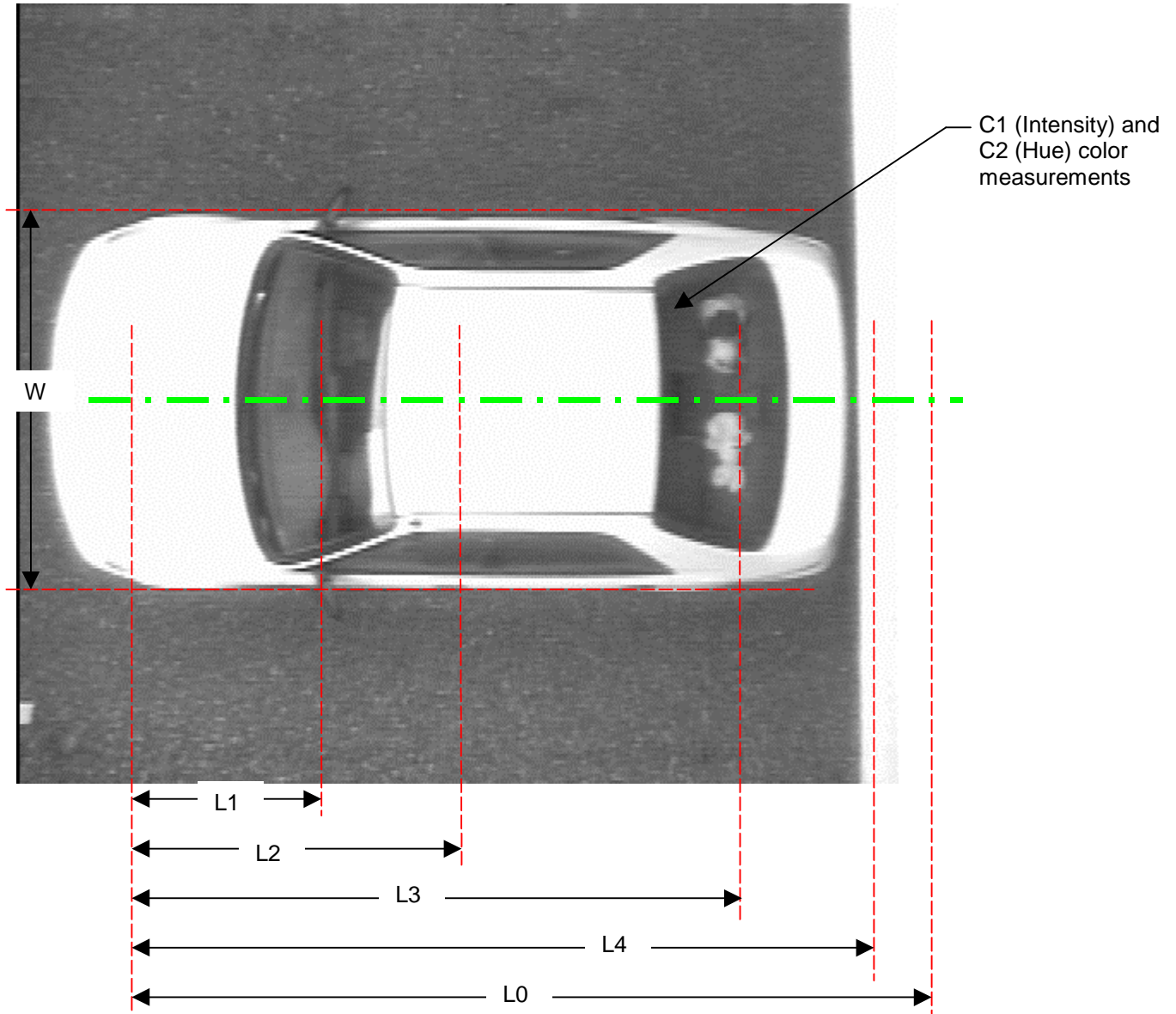

Figure 5. VSV Vector Component Measurements for Typical Raw Vehicle Image.

As a vehicle passes under the detector (of known height above the road surface), a minimum of twelve video fields are acquired under worst case conditions (low camera placement, 70 mph vehicle speed, 20 ft detection path):

Capture rate = 60 fields/second
 Vehicle rate = 70 MPH = 102 Feet/Second
 1 Second = 60 Video Fields

Video Capture Area = 15 x20 Feet
 Capture Length = 20 Feet

102 Feet / 60 Fields = 1.7 Feet traveled between each field
Video detection path / Distance traveled between each field = 20 Feet / 1.7 Feet = 12 Video Fields

Chromatic hue, saturation and intensity characterize each color pixel. Since shadows manifest as changes in Intensity (luminance) level only, and have only a secondary effect on the color phase (hue) value, shadow rejection is enhanced.

The true vehicle centerline is determined by locating the locus of equidistant points between the symmetric boundaries of level changes on both sides of the object in the image. Optical signature features are detectable by differentiation along the vehicle centerline, as illustrated in Figure 6.

While only a secondary consideration in the VSV, the speed of the vehicle as it traverses the detection area can easily be detected. Since the overall geometry of the detection area is known, this measurement is easily found from temporal (frame-to-frame) "time of flight" measurements [2,5,7]. As the vehicle moves through the detection zone, the optical flow front is detected as a change in H (hue) and I (intensity) compared with the accumulated background. Along the vehicle centerline, H and I level changes occur at features such as the windshield and rear window. These inflection points in the video signature constitute the basis for the length metrics (L0 - L4). This collection of information is packaged and transmitted as a VSV for each detected vehicle.

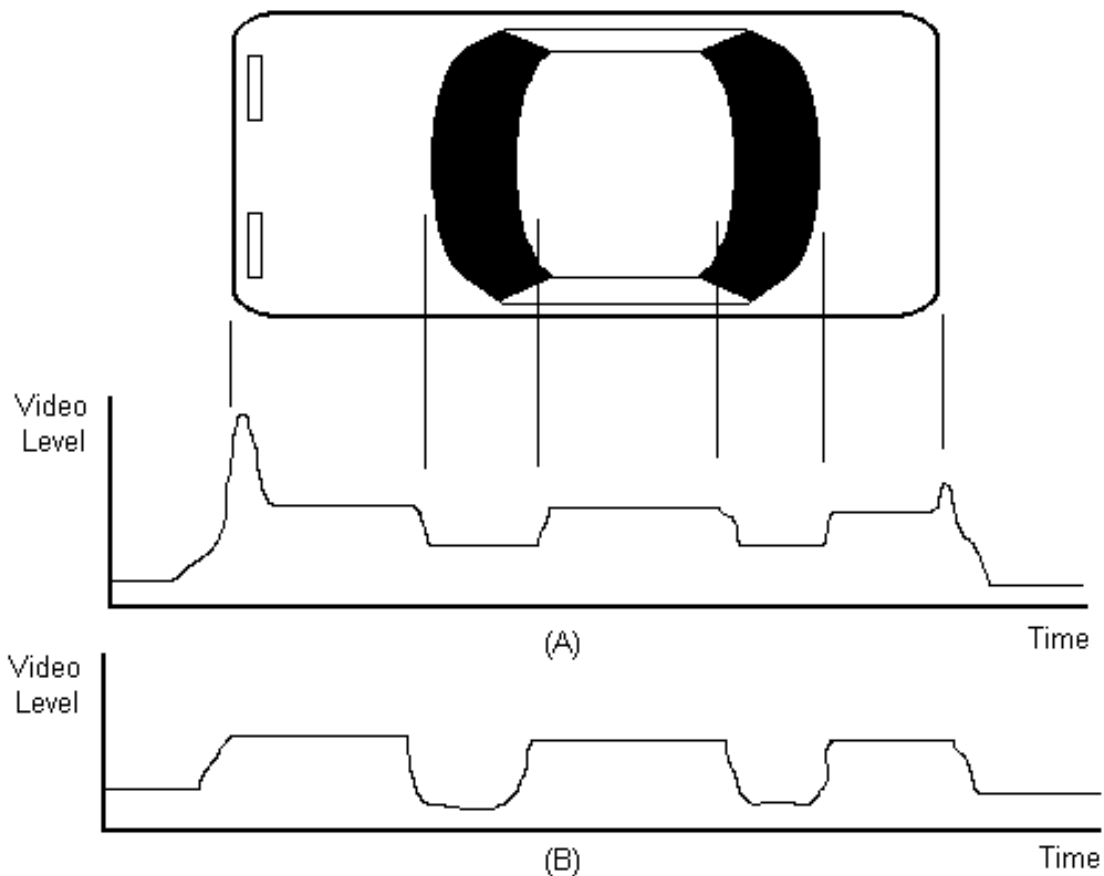

Figure 6: A typical video intensity profile of a vehicle (A) at night with the head and tail lights illuminated, and (B) during daylight hours.

Field Data Acquisition

Two sets of time-synchronized video data acquisition and vector generation apparatuses were deployed at consecutive overcrossings, spaced 0.5 to 0.6 mile apart, on US Hwy 101 in three different locations in the California Central Coast area. Traffic conditions were light to moderate (LOS B-C) for all cases. For Phase one study purposes, these traffic conditions were ideal for data collection and ease of data reduction. Note that traffic density should (theoretically) not have any direct effect on the system accuracy, provided that the computer vision hardware can process vehicle images at a rate fast enough to keep up with traffic flow.

Trip #1a and Trip #1b (2/8/97)

US 101, Monterey St. and California St. overcrossings.
0.5 mile separation.
Dusk (1a) (16:00-17:30) and night (1b) (17:30-19:00).
Number 2 lane, south bound traffic.
Cameras: Monterey – Minitron, California – Burle.
Shutter speed: Day - 1/4000 sec both cameras;
 Night - Minitron: 1/4000, Burle: Autosshutter
Road surface: Asphalt (dark) both locations.
Vehicle totals: Trip1a: 103 vehicles in 31 minutes. Trip1b: 102 vehicles in 26 minutes.

Trip #2 (4/15/97)

US 101, California St. and Santa Rosa St. overcrossings.
0.6 mile separation.
Daytime / early afternoon (13:00-15:00).
Number 1 lane, North bound traffic.
Cameras: California – Minitron, Santa Rosa – Burle.
Road surface: Asphalt (dark), both locations.
Shutter speed: 1/4000 sec fixed, both cameras.
Vehicles total: 102 vehicles in 20 minutes.

Trip #3 (4/29/97)

US 101, Highway 246 and North Buelton Rd. overcrossings.
0.5 mile separation.
Daytime / late morning (10:00-12:00).
Number 1 lane, North bound traffic.
Cameras: Highway 246 – Minitron, N. Buelton – Burle.
Road surface: Concrete (light colored), both locations.
Shutter speed: 1/4000 sec fixed, both cameras.
Vehicles total: 110 vehicles in 60 minutes.

Trip #4 (4/29/97)

US 101, Monterey and California St. overcrossings.
0.5 mile separation.
Night (19:00 – 21:00).
Number 2 lane, North bound traffic.
Cameras: Monterey – Burle, California – Minitron.
Road surface: Asphalt (dark), both locations.
Shutter speed: Autosshutter, both cameras.
Low or no ambient illumination restricted useful detection.

Figure 7 shows the apparatus deployed on the Santa Rosa Street (San Luis Obispo) overcrossing over north-bound US Hwy 101 during mid-day conditions. Figure 8 shows the apparatus deployed on the California Street (San Luis Obispo) overcrossing over northbound Hwy 101 at night.



Figure 7. Typical Daytime Deployment of Phase 1 Data Acquisition System on Freeway Overcrossing.

The video cameras for each apparatus were deployed approximately 0.5 meter horizontally off the side of each overcrossing deck, facing straight down, with a field of view slightly larger than one lane. Cameras were oriented such that when viewed on a monitor vehicles appear to flow laterally across the screen. S-VHS video tape recorders in each apparatus were used to record concurrent records of individual vehicles as they pass below the video cameras at each of the two sites. Radio communication between the sites was maintained to assure exact vehicle-to-vehicle synchronization. Approximately fourteen total hours of S-VHS video tape were recorded at each pair of sites.



Figure 8. Typical Night Deployment of Data Acquisition System on Freeway Overcrossing.

Figures 9a and 9b are digitized and printed video frames of a randomly selected vehicle at two different overcrossings, located approximately 0.6 miles apart. Both sites observed lane number 2 on a four-lane (two in each direction) section of the highway. An adjoining on/off ramp at the second site effected the consistency of the traffic flow. The vehicle speed at the time of acquisition was approximately 65 mph at both sites. Time of day: 4:30 PM, from the afternoon data set. Long stationary shadows were present at both sites, which extended completely across the vehicle detection zones. Cameras at both sites were color with electronic shutters, both set to 1/4000 second. At this shutter speed, blur due to vehicle motion was found to be virtually nonexistent. The reduced resolution observed at the second site can be attributed to the use of a 1/3 inch CCD imager, while the first site used a 1/2 inch CCD imager, with approximately twice the number of available pixels. The test conditions for this sample frame pair were considered approximately average for the detection problem - adequate light for clear color information and dimensional measurements, but some challenges associated with reduced intensity and steep incidence angle illumination.

Graphical measurements during Phase 1 from both these images show a clear and repeatable measurement of L0, L1, L3, L4 and W. C1 (color intensity) and C2 (color hue angle) are also clearly discernible in both images. In this particular situation, the proposed VSV vector provided very good characterization and unique re-identification of most vehicles with a high degree of reliability. As the sun set (dusk), however, it became difficult to discern color measurements, and eventually (night), the dimensional measurements as well.

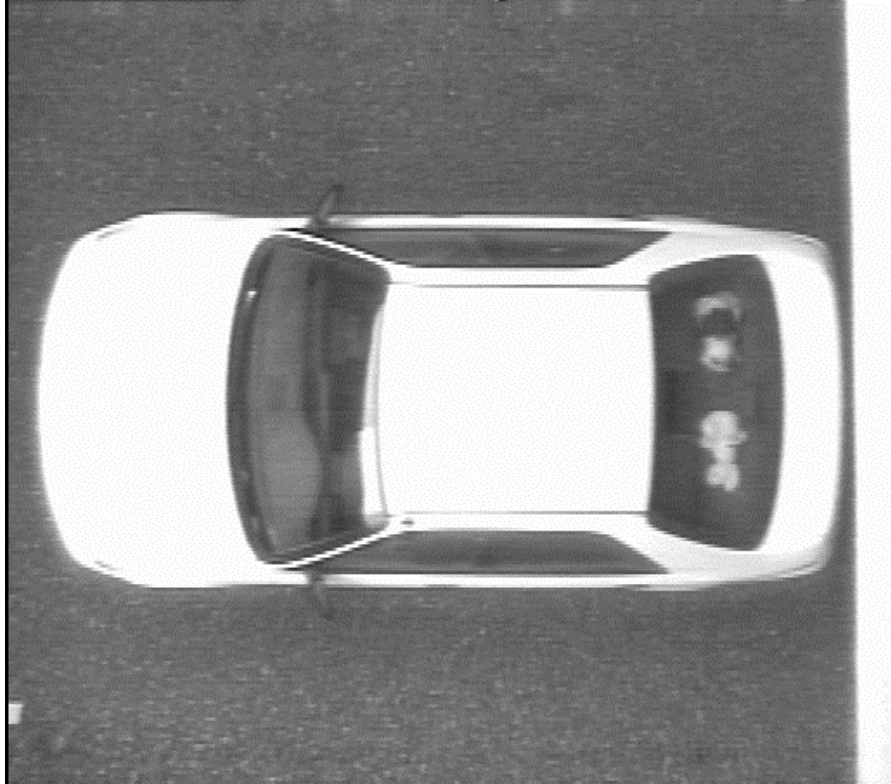

Figure 9a. Vehicle at Monterey St/Hwy101 Overcrossing

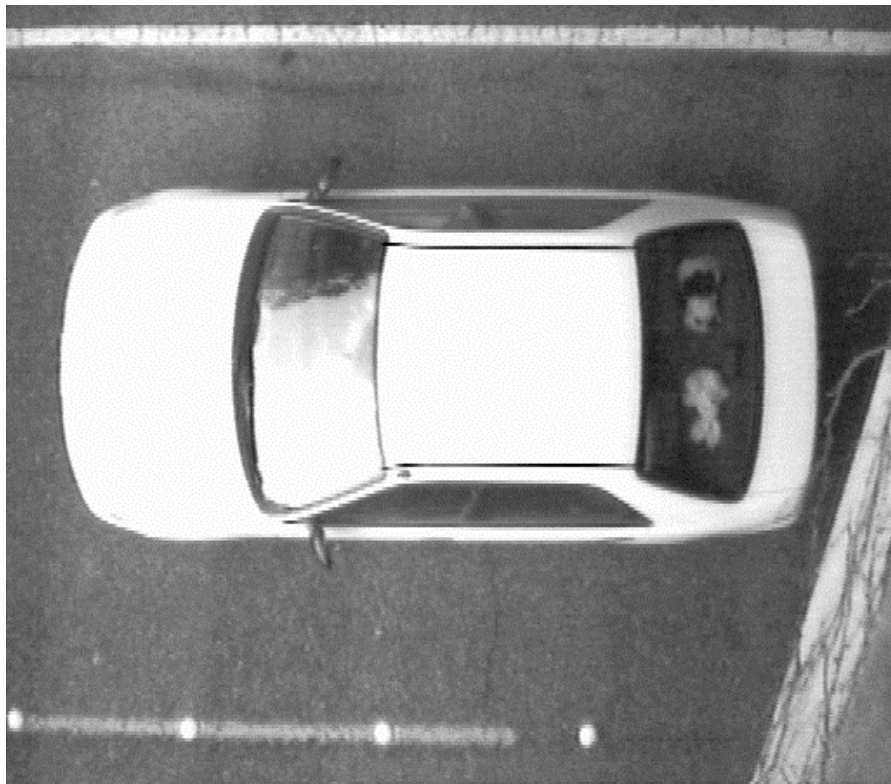

Figure 9b. Vehicle at California Ave/Hwy 101 Overcrossing

After preliminary tests in Phase 1, we standardized on the use of a relatively fast camera shutter speed (1/4000 sec). While this eliminated image blur, it pushed the limits of sensitivity of both video cameras. As a result, color perception was diminished fairly early in the dusk transition, and completely absent at night. The ramifications of allowing slower shutter speeds are illustrated in Figure 9, in which the automatic shutter feature of the Burle camera was enabled and the shutter speed defaulted to 1/60 second, the slowest possible speed. At 65 MPH, the vehicle travels 1.59 ft. (0.484 m) during this maximum integration interval. Color perception is retained even at low light, but the vehicle edges are severely blurred, probably beyond the capability of the computer vision algorithm to reliably determine the true points of optical contrast of the object. We opted for blur reduction over sensitivity for Phase 1 because the video data was to be reduced manually, without the benefit of the computer vision algorithm which should be capable of determining crisp points of optical demarcation from blurred image features. In future work using the machine vision system for VSV generation, we estimate that a shutter speed of about 1/1000 second would probably be a reasonable tradeoff between sensitivity and blur reduction.



Figure 10. Image Blur Due to Slow Shutter Speed Under Low-Light Conditions.

Review of Phase 1 Results on Uniqueness and Repeatability of the VSV

The videotaped images from the field were then analyzed manually in the laboratory to test the accuracy and repeatability of the optical signature vector for characterizing and re-detecting vehicles, as well as to assess the general usability of the vector as a means for classifying a range of vehicles by dimensional measurements. Vehicle dimensional measurements were made from the CRT face of a Sony Trinitron PVM1344Q reference monitor, which was calibrated using a "pin cushion" electronic test pattern to maintain perfect geometric linearity. Primary vehicle color hue and saturation were determined by isolating a target area in the image, and processing the area using a Data Translation DT 2871 color image processing card and specialized image analysis software we wrote for this purpose. A copy of the C source code for this PC-based program, PCOL.C appears in the Appendix.

In our data reduction, we were attentive to issues related to the use of chromatic information to discriminate actual vehicles from shadows and headlight reflections, the effects of video blur at high vehicle speeds on dimensional measurements, and the impact of different and time-varying illumination conditions between successive detection sites. For our semi-automated data reduction, none of these posed a significant measurement problem. However, we had the benefit of human perception when determining object edges and corresponding feature length measurements. We expect that a purely machine-vision mechanization of the V²SAT algorithm will encounter significant challenges in robustly discriminating true object features and color characteristics independent of ambient illumination.

Table 1. Preliminary Study of Uniqueness of VSV Elements.

Number	Lo	L1	L2	L3	L4	W	Vel In/s	color	comment	match	notes
1	10.25	3	4	10.25	1.025	3	1	blue			1) Monitor on underscan
2	9	3.25	4.25	7	8	3.125	0.875	red			2) Measured entire blur as car
3	8.5	3.875	4.5	6.5	7.25	2.625	0.75				3) Used Sony monitor
4	8.75	2.375	4	7	8.75	3	0.75	red			4) Used test tape with sideways approaching cars
5	9.75	3.5	4.25	9.75	9.75	3.5	0.75	white			5) Lane Width = 6.75 in which is equivalent to 12 ft in reality.
6	8.5	3.1875	4	8.5	8.5	2.75	0.625	silver			
7	8.5	2.75	3.75	4.375	5	2.875	0.75	blue	sun roof		
8	10.75	3.375	4.25			3.5	0.75	green	truck w/ stuff in back		
9	10.875	3.5	4.5	7.25	8.5	3.5	0.875	blue	truck empty		
10	10	3.875	4.75	10	10	3.5	0.75	grey	car w/light col rear window		
11	10	3.75	4	6.75	7.5	4.5	0.6875	blue	truck w/ stuff in back + mirror on side		
12	8.5	2.125	4.375	6.5	8.5	3	0.75	black			
13	10	3.125	4	6.5	10	3.5	0.75	white	truck w/ stuff in back		
14	8	3	3.75	7.5625	8	2.75	0.6875	lt yellow	great contrast		
15	9	2.875	4.5	9	9	3	0.75	dk red	Bk window too hard to detect w/light		
16	11	3.5	4.25	11	11	4.125	0.75	lt yellow	truck w/ side mirror (width meas)		
17	9.75	3.125	3.625	9.75	9.75	2.875	0.75	lt yellow	truck w/ no side mirror		
18	10.25	3.875	4.125	6.5	10.25	3.875	0.6875	lt yellow	truck w/ stuff in back		
19	9	1.75	3.5	9	9	3	0.75	black	mini van		
20	8.5	3	3.75	8.5	8.5	3	0.75	gold	too hard to det rear window		
21	8.5	3.125	4	8.5	8.5	2.9375	0.75	lt yellow	too hard to det rear window		
22	9.5	3.125	4.25	7	8.5	3.25	0.6875	dk blue			
23	8.25	2.75	3.75	6.5	7.5	2.875	0.75	dk blue			
24	9.75	3.75	5	9.75	9.75	3.25	0.75	grey	too hard to det rear window		
25	10.75	3.5	4.25	10.75	10.75	3.625	0.75	white	suburban truck with luggage rack	1	
26	8.25	3	3.75	8.25	8.25	3	0.75	white	too hard to det rear window		
27	9.875	3.75	4.5	9.875	9.875	3.25	0.6875	gold	too hard to det rear window		
28	9.25	3.25	4.5	9.25	9.25	3.25	0.75	gold	too hard to det rear window		
29	9	2.5	3.5	5	9	3	0.75	dk red	truck w/ white boxes in back		
30	9	3.25	3.5	9	9	3.125	0.75	lt yellow	truck w/ no rear window poor contrast on window		
31	6.5	2.5	3	6.5	6.5	2.75	0.75	white	small hatch back car		
32	8	3	4	6.25	7	2.75	0.75	dk blue			
33	10.25	3	4.5	10.25	10.25	3.25	0.75	dk green	truck w/ nothing in back		
34	9	3	3.75	4	5	3.25	0.75	lt blue	truck w/ sun roof (toyota 4runner)		
35	6.75	2.5	4	4.25	4.75	2.75	0.6875	red	small hatch back car (hard to detect rear end)		
36	8.75	1.75	3.5	8.75	8.75	3.25	0.75	dk red	mini van		
37	10.75	3.5	4.25	10.75	10.75	3.625	0.6875	white	suburban truck with luggage rack	1	

Table 1 shows the results of a preliminary data collection exercise, intended only to assess the relative uniqueness of the VSV vector for a random sample of vehicles. Data for this table was collected at one site only, northbound lane #1 US 101 at Los Osos Valley Overcrossing in Caltrans District 5. Test conditions were late afternoon, clear, traffic approximately LOS C-D. Among the 37 vehicles analyzed, all had sufficiently distinctive VSV vectors to discriminate them uniquely for detection purposes, with the exception of two, noted with “match=1”. These were identical white Chevrolet Suburban trucks with luggage racks. The time separation between them would probably have been sufficient to distinguish them as they pass through a freeway network. From this preliminary exercise, we concluded that the proposed VSV provided, in most cases, sufficient unique information about each vehicle to distinguish it from other vehicles. We also were able to determine the optimum camera field of view (lens focal length), shutter speed (set electronically), and aperture (F-stop) for our subsequent field data collection trips.

Phase 1 Correlation Method

VSVs generated for each vehicle at each detector site are correlated pair-wise using a normalized cost function that increases in value with increased differences between the elements of the compared vectors. It will be referred to as the *correlation error e*.

$$e = \frac{\left(\frac{c_0 |L0_1 - a \cdot L0_2|}{L0_1} + \frac{c_1 |L1_1 - a \cdot L1_2|}{L1_1} + \frac{c_2 |L2_1 - a \cdot L2_2|}{L2_1} + \frac{c_3 |L3_1 - a \cdot L3_2|}{L3_1} + \frac{c_4 |L4_1 - a \cdot L4_2|}{L4_1} + \frac{c_5 |W_1 - a \cdot W_2|}{W_1} + \frac{c_6 C1_1 C1_2 |C2_1 - a \cdot C2_2|}{C2_1} \right)}{c_0 + c_1 + c_2 + c_3 + c_4 + c_5 + c_6 C1_1 C1_2}$$

where subscript 1 \Rightarrow vector component measured at first detection site, and subscript 2 \Rightarrow vector component measured at second detection site.

a = dimensional correction factor = ratio of detector height at site 1 to height at site 2.

c_k = component weighting coefficient. For Phase 1 tests:

$c_0 = 0.4$, $c_1 = 0.2$, $c_2 = 0.2$, $c_3 = 0.1$, $c_4 = 0.1$, $c_5 = 0.3$, $c_6 = 0.3$

If any component was not present in the vectors from both sites, the coefficient for the missing term was set to zero in the calculation of *e*.

For Phase 1 evaluation purposes, we defined two restricted versions of the VSV, since such elements as the site code, lane number and vehicle speed were irrelevant to the study. The first is referred to as the “full” vector, comprised of 8 measured elements:

VSV Components, Full: L0, L1, L2, L3, L4, W, C1 (Intensity), C2 (Hue Angle)

The second “reduced” vector lacks the last two dimensional measurements and all color information:

VSV Components, Reduced (preliminary tests only): L0, L1, L2, W

The reduced vector was used only for preliminary daylight data collection, since we had not yet developed the computer-based color analysis program which provided an objective quantitative indication of color characteristics for each vehicle. The full vector was used to process all field data to yield the results reported for all conditions. All results are summarized in the following section, and supporting EXCEL spreadsheets containing all raw data are included in the Appendix.

The detectability and uniqueness of the VSV are tested by using the correlation error *e* as a means for comparing the VSV of each vehicle with the VSV of either itself or another vehicle at another detection site. A match is declared if the correlation error *e* for the two VSVs is less than some specified threshold e_T . Detection thresholds for these tests were generally selected to be inversely proportional to the illumination level for each condition. Thresholds were not optimized. As previously discussed, *e* is an

indication of the relative “closeness” of each pairing of VSVs. Data are segregated according to the average illumination condition present during each test. Four illumination categories are represented: late morning, early afternoon, dusk, and night. Table 2 below states the detection threshold used for each illumination condition.

Table 2. Detection Threshold for each Test Condition.

	Detection Threshold e_T
Mid-day	0.03
Afternoon	0.04
Dusk	0.05
Evening	0.10

We will refer to the ability of the VSV to match the same vehicle at successive sites as the vector *auto-correlation*. The tendency of the VSV to incorrectly match different vehicles at successive sites is referred to as the vector *cross-correlation*. These definitions differ from, but are similar to the formal statistical definitions of auto-correlation and cross-correlation.

Self-correlation (Correct Match for Same Vehicle at Different Sites)

For each vehicle that passes through both detection sites, the VSV generated for it at Site 1 is compared with the VSV generated for it at Site 2. A “match” is declared if $e < e_T$. We report in Table 3 the **Average % Self-correlation** as the sample mean of $(1 - e) \times 100\%$ for all pairs of VSVs measured at two consecutive detection sites. The percentage of the total number of vehicles which are matched is reported as a match the **% Correct Vehicle Match**. A failure to match is assumed to be due to measurement errors, usually attributable to the presence of image artifacts, inaccurate height correction, or the effects of uncorrectable angular aberrations which distort the translation from ground coordinates to image coordinates. Some errors may simply be due to poor precision in the dimensional measurements made by research assistants responsible for processing the raw video data.

False Correlation (Incorrect Match of Different Vehicles at Different Sites)

The VSV generated for each vehicle at Site 1 is compared with the VSV for every vehicle in the data set at Site 2, excluding itself. A (false) match is declared if $e < e_T$. The **% False Vehicle Match** in Table 3 is the percentage of times that vehicles were (incorrectly) reported as matches, over all possible pairings of different vehicles. False matches are usually observed in cases of different vehicles of the same or similar make, model and color, although measurement errors can also contribute to a random increase in some correlations to a degree necessary to satisfy the detection threshold criteria.

Table 3. Self-correlation and False-correlation Test Results.

Illumination Condition	Total Vehicles	Average % Auto-correlation	% Correct Vehicle Match	% False Vehicle Match
Mid-day	110	98.70%	97.27%	0.22%
Afternoon	90	98.59%	98.89%	1.66%
Dusk	103	98.41%	95.15%	2.02%
Night	102	92.47%	75.49%	27.05%

Notes:

For auto-correlation: VSV generated for each vehicle at Site 1 and then at Site 2 are compared.
 For false correlation (cross-correlation): VSV generated at Site 1 for each vehicle is compared with VSV generated for *all other* vehicles at Site 2.
 VSV match thresholds specified in Table 2.
 % false vehicle match performed over entire data set for each specified illumination condition.

Table 4. Detailed Match / no-Match Results for Each Test Condition.

a. Mid-day:

Summary of Correlation Results (Mid-day, Thresh=0.03):

	Same Vehicle		Different Vehicle	
Match	107	97.27%	26	0.22%
No Match	3	2.73%	11964	99.78%
Total Comparisons	110		11990	

b. Afternoon:

Summary of Correlation Results (Afternoon, Thresh=0.04):

	Same Vehicle		Different Vehicle	
Match	89	98.89%	133	1.66%
No Match	1	1.11%	7877	98.34%
Total Comparisons	90		8010	

c. Dusk:

Summary of Correlation Results (Dusk, Thresh=0.05):

	Same Vehicle		Different Vehicle	
Match	98	95.15%	212	2.02%
No Match	5	4.85%	10294	97.98%
Total Comparisons	103		10506	

d. Night:

Summary of Correlation Results (Night, Thresh=0.10):

	Same Vehicle		Different Vehicle	
Match	77	75.49%	2787	27.05%
No Match	25	24.51%	7515	72.95%
Total Comparisons	102		10302	

For the mid-day test condition, the sun angle was approximately vertical. Dimensional measurements were generally accurate, and color information was available. Vehicle re-identification (auto-correlation) and vehicle discrimination (cross-correlation) results were generally very good. Figure 11a illustrates a typical correlation error e for a white mini-van (vehicle 25). e was very small for the vehicle compared with itself (vehicle 25) but was well above the detection threshold, shown as a dashed line, for all other vehicles in the data set. Vehicles which greatly differed from the norm, such as the semi-truck of Figure 11, tended to have very large cross-correlation errors, which clearly distinguished them from conventional automobiles. Cases such as vehicle 33 in Figure 11b, for which e was small, were similar semi-trucks.

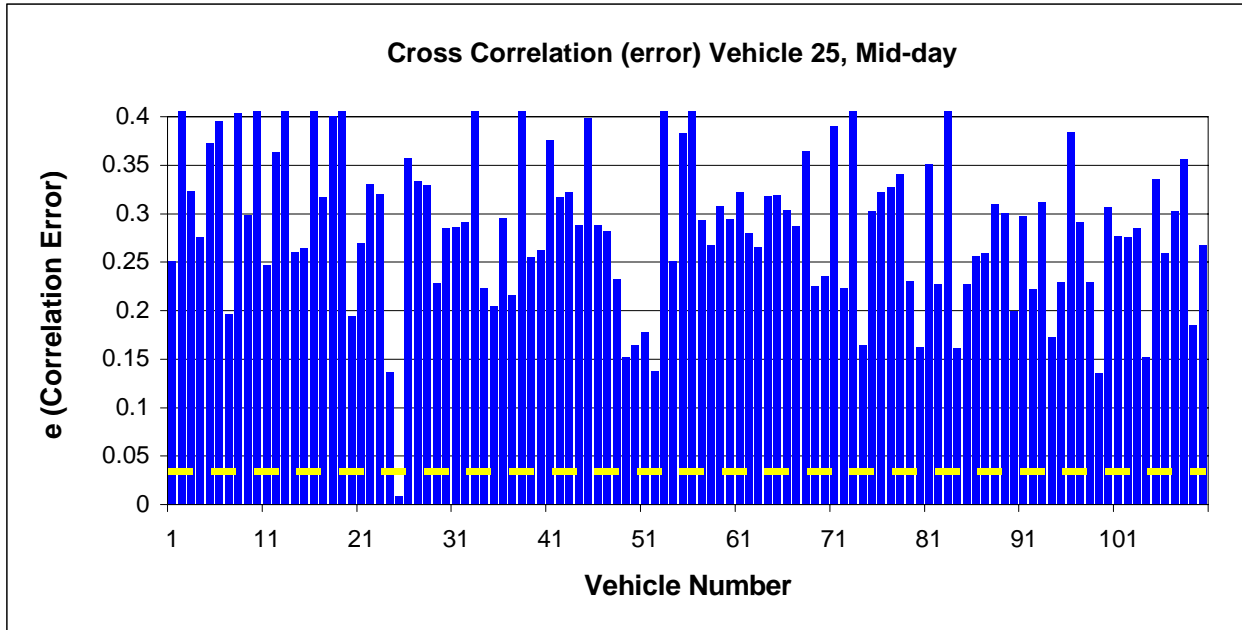

Figure 11a. Correlation Error, Vehicle 25 (White Mini-van), Mid-day, Overhead Sun.

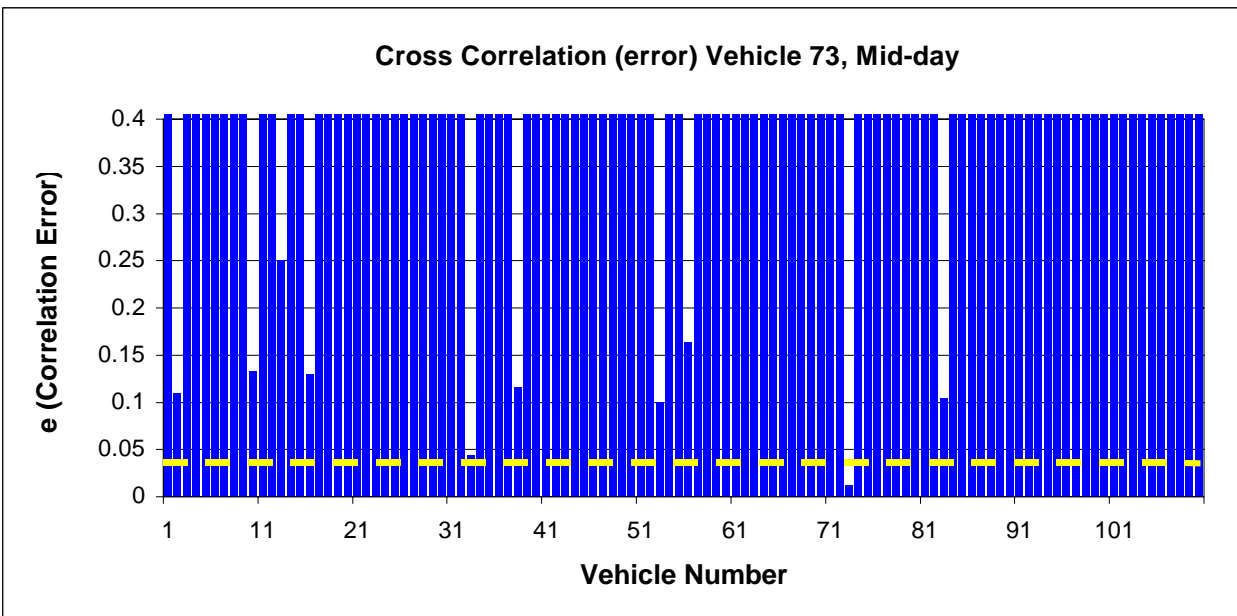

Figure 11b. Correlation Error, Vehicle 73 (Semi-truck/trailer), Mid-day, Overhead Sun.

Figures 12a and 12b illustrate afternoon test condition, bright sun at approximately a 45 degree angle. The plots show the correlation error e for vehicles 19 and 78 among all vehicles arriving at Site 2. Vehicle 19 was a green sport utility vehicle (SUV). Vehicle 78 was a blue sedan. Both vehicle types were commonly observed. The detection threshold was $e_T = 0.04$ for this condition. As indicated in Table 4b, re-identification improved and discrimination degraded compared with the mid-day condition, but neither change was significant. Adjustment of e_T results in a tradeoff between these factors. The observed difference is consistent with e_T being slightly greater than that used for the mid-day condition.

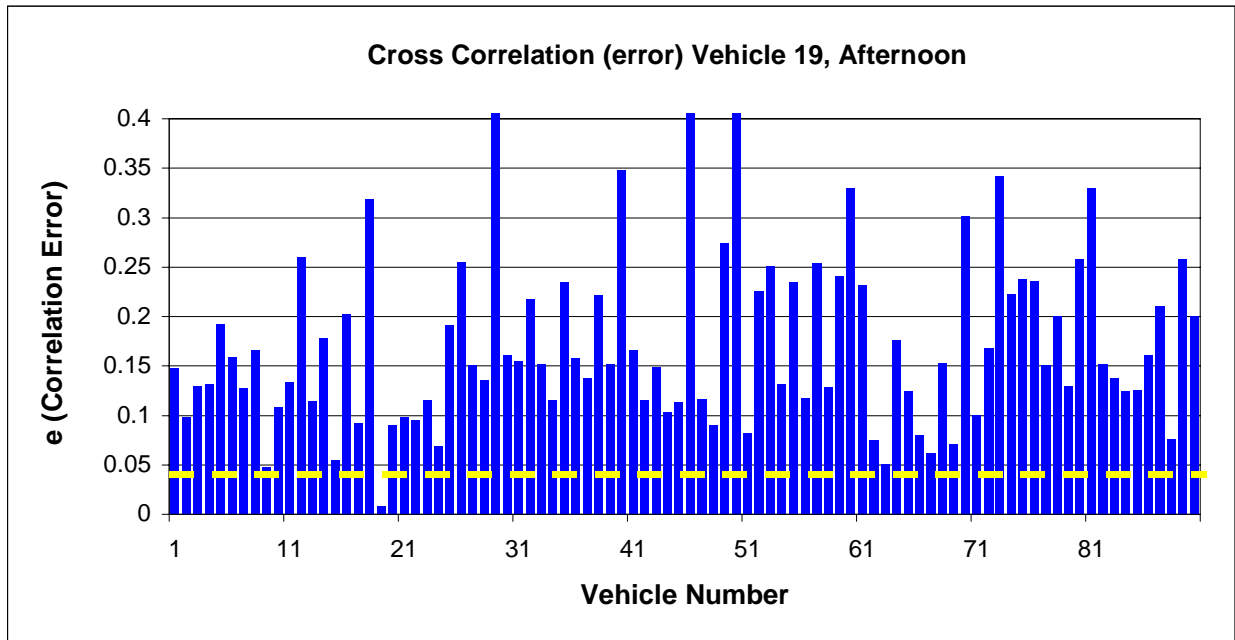

Figure 12a. Correlation Error, Vehicle 19 (Green SUV), Afternoon.

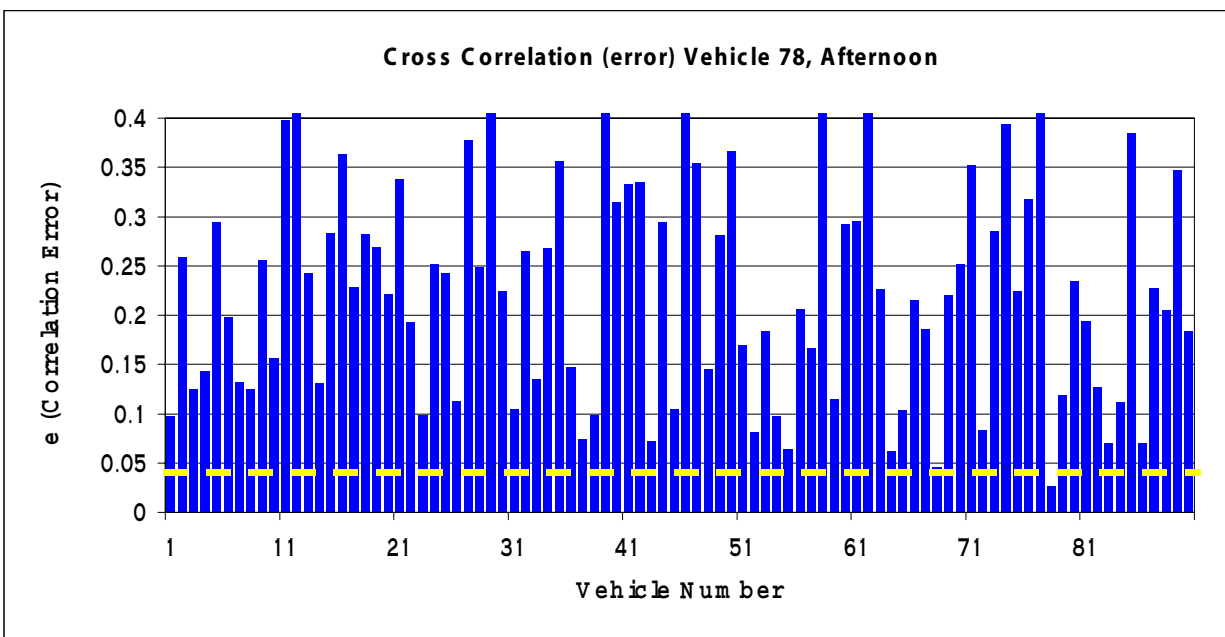

Figure 12b. Correlation Error, Vehicle 78 (Blue Sedan), Afternoon.

During late afternoon and sunset, we begin to see long shadows and reduced illumination. For our manual data reduction, the presence of shadows only marginally degraded the dimensional VSV measurements. However, the reduced illumination caused our computer measurements of color to be inaccurate. Average auto-correlation was only trivially reduced compared with the afternoon condition. With $e_T = 0.05$, re-identification and discrimination ability both suffered, although not to a degree that would make the detection method unacceptable. Figures 13a and 13b below illustrate the correlation error e for a white pickup truck and a white minivan. Vehicle 24 in Figure 14 is falsely matched with vehicle 20.

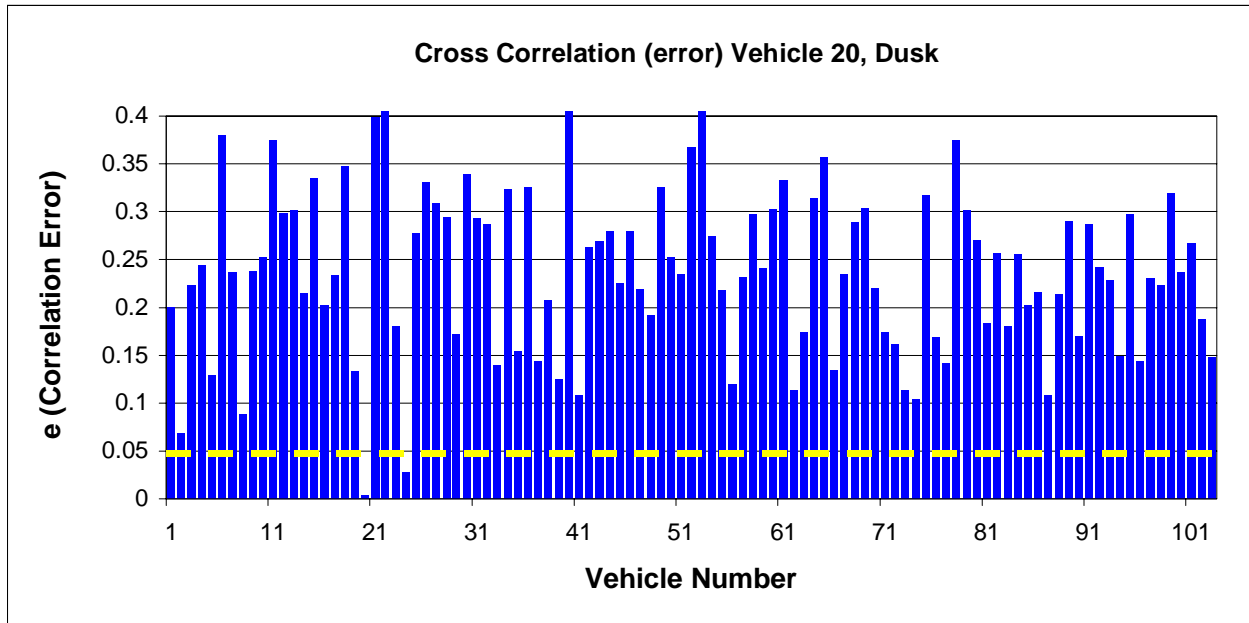

Figure 13a. Correlation Error, Vehicle 20 (White PU Truck), Dusk.

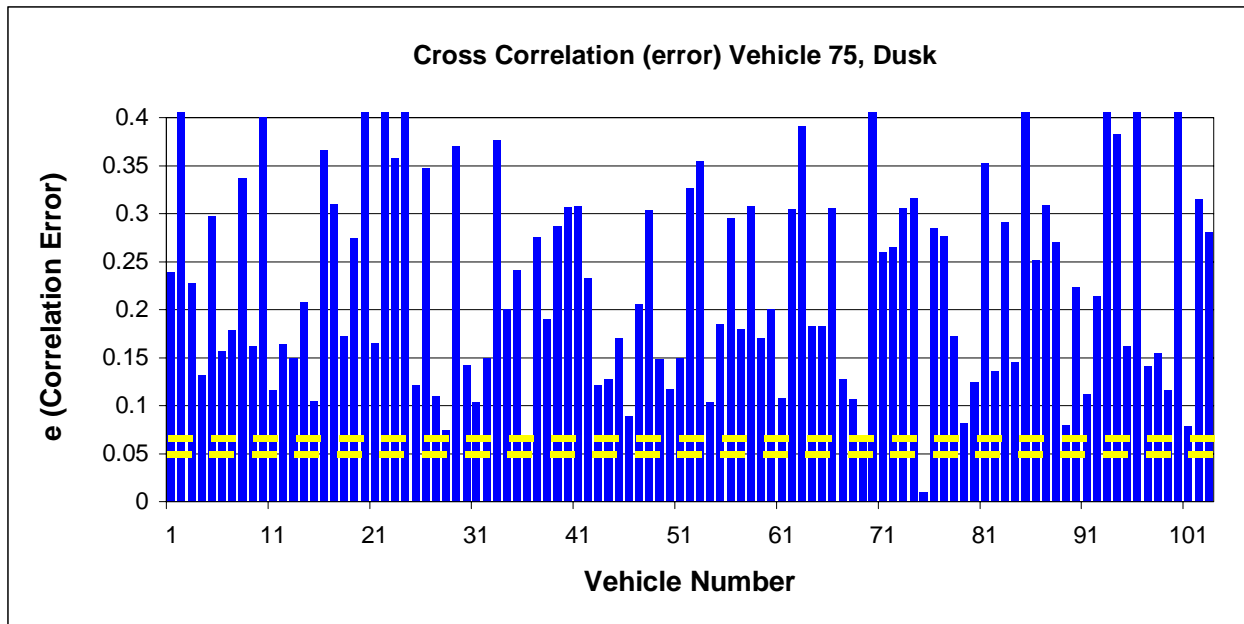

Figure 13b. Correlation Error, Vehicle 75 (White Mini-van), Dusk.

Under low-light conditions, auto-correlation decreases and cross-correlation increases, approaching the point at which the uniqueness of detection is unreliable. This condition is illustrated in Figures 14a and 14b below. Color information is absent from most of the VSVs that constitute this data set. $e_T = 0.01$ for this condition. In Figure 14a, vehicle 22 appears well-differentiated within a “reasonable time of arrival” window, but would be indistinguishable from vehicles 2, 7, 13, 32, 40, 50, 69, 75, 91 and 97 found outside of this time window. At some minimum illumination, the VSV cannot be reliably measured, so that e (for both correct and false pairings) dramatically increases, as illustrated in Figure 14b below.

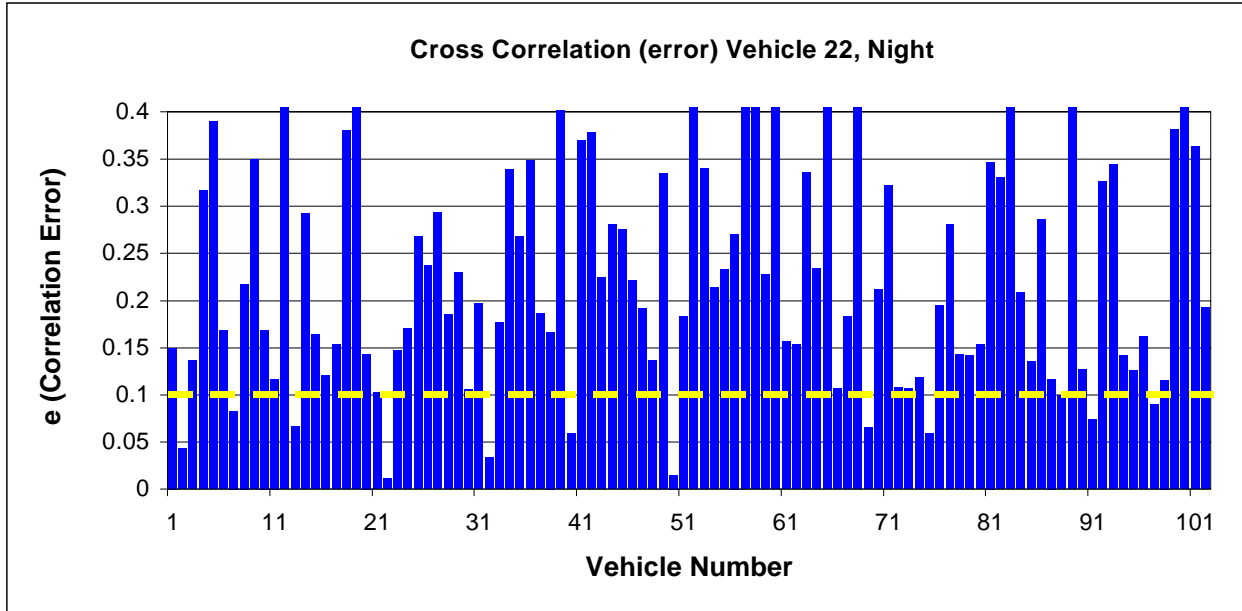

Figure 14a. Correlation Error, Vehicle 22 (Red Station Wagon), Night.

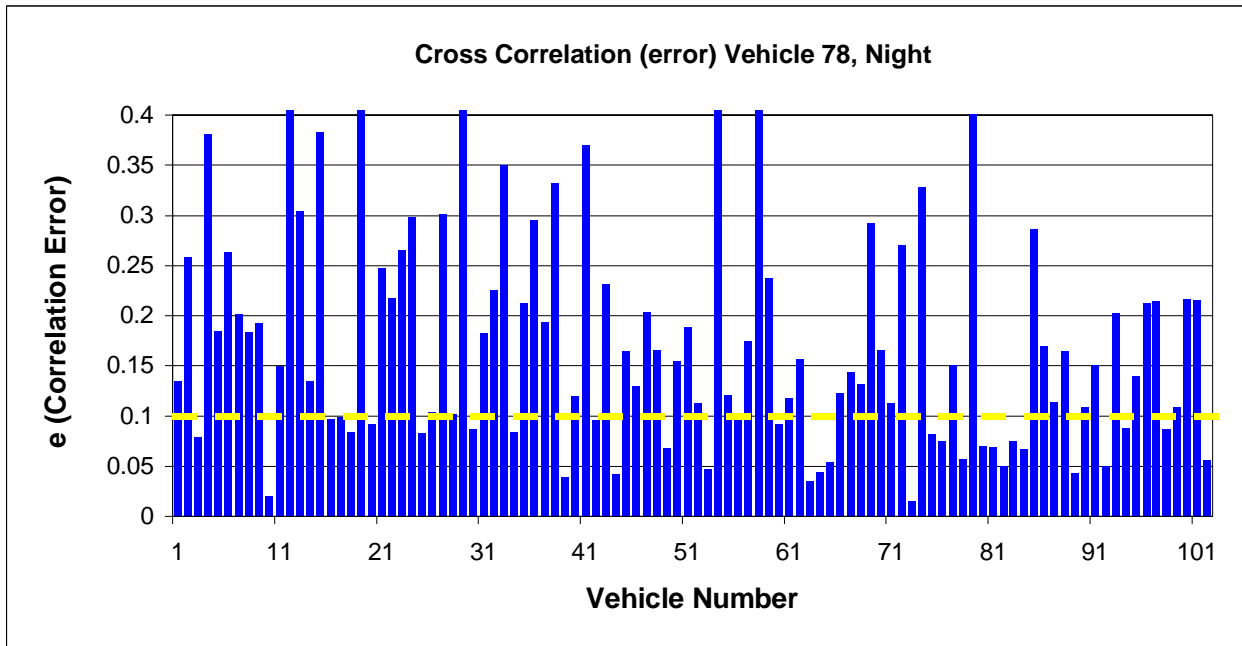

Figure 14b. Correlation Error, Vehicle 78 (Station Wagon, Undetectable Color), Night.

Relative Value of Vehicle Color and Reasonable Time of Arrival Window

For the *daylight* conditions only, we studied the relative contribution of the color components of the VSV to the accuracy of site-to-site auto-correlation and cross-correlation. We only examined daylight (mid-day and afternoon) conditions since color information was not available at night, and was not reliable during dusk transition conditions. We were motivated to examine separately this vector component because of the significant incremental cost associated with acquiring and analyzing color images with machine vision. Even during daylight conditions, it was not always possible to obtain a reliable electronic measurement of a vehicle's primary color, especially cases of low color saturation. Color saturation for each vehicle was generated by our computer color analysis program, and is reported on all data spreadsheets (in the Appendix) as "S" in raw binary units (0-255). Low color saturation would roughly correspond to $S < 64$. Saturation was recorded only to allow us to study the "loss-of-color" threshold, and was not itself used as a vector component. Based on the results shown in Table 5 below, we conclude that color information, if it can be obtained, is of significant value in the VSV.

We also examined the data to assess, in a crude sense, the relative additional value of restricting vehicle vector comparisons to within some reasonable time of arrival. The admissible vehicles in each case were determined by allowing comparisons only for vehicles that could have gone from Site 1 to Site 2 between the speeds of 30 and 80 MPH. For a 0.5 mile site separation, this corresponded to a time-of-arrival aperture at site 2 of between 22.5 and 60 seconds. The site pair separations for each of the two daylight condition (mid-day and afternoon) were 0.5 and 0.6 miles, and that traffic conditions were light (typically 3-4 vehicles per minute per lane). Therefore, the use of a "reasonable time of arrival" window typically admitted only between one and four vehicles, one of which was the actual vehicle detected at the first site.

Table 5 reports percent matches among all comparisons, either of the vehicle with itself (correct match) or with a different vehicle (false match). The data trend toward better accuracy when using a restricted arrival window is considered valid, but the exact percentages reported (99% auto-correlation, 0% false correlation) are not considered reliable due to the very small number of vehicles admitted by the time window for our test configurations. With higher density traffic are greater site separation, many more vehicles would be admitted in the time window, so that a non-zero percentage of false matches would be assured.

Table 5. Limited Examination of the Contribution of Color Elements in the VSV, and the Relative Value of a "Reasonable Time of Arrival" Window.

	<i>VSV w/o Color</i>	<i>VSV w/ Color</i>	<i>w/ Color and Reasonable Time-of-arrival Window</i>
% Correct Matches	98.3 %	99.0 %	99.0%
% False Matches	5.4%	0.3%	0%

Image Sensor Performance and Selection Considerations

The cameras utilized in Phase 1 preliminary work were not identical, but were generally matched in performance. Camera 1 was a Minitron GM470C ½ inch CCD color camera specified as having a 450 line resolution and “high” sensitivity. Its purchase price without lens was \$495 USD. Camera 2 was a Burle TC9388-1 1/3 inch CCD color camera, specified as having a 380 line resolution and “high” sensitivity. Its purchase price (1995) was \$625 USD.

In general, the exceptionally low cost and high signal information content of solid state (chip) video cameras make them hard to beat as primary detectors for this application. Solid state cameras are compact, and low in power consumption. However, certain limitations of current-technology solid-state cameras preclude certain classes of cameras from consideration [4,6,7]. State-of-the-art monochrome CCD (charge coupled device) surveillance cameras are characterized by exceptional sensitivity, but are plagued by the problem of vertical or horizontal smear when a bright light source appears in the field of view. This image artifact occurs when vehicle headlights are on during periods of darkness. The resulting long white streaks in the video image confound all vision-based traffic detection algorithms that we are aware of. Both of our test cameras exhibited problems with vertical smear. The Minitron camera (higher resolution but lower cost) also exhibited this problem during bright daylight conditions, due to sunlight reflection off of chrome or polished surfaces of some vehicles.



Figure 15. Digitized Video Image of Night Highway Traffic, Burle TC9388-1 Camera, Auto-shutter mode.

Since the detectors are required to be fully operational under both daylight and darkness conditions, this limitation is a significant obstacle. This is a fundamental characteristic of the technology which cannot be corrected by signal post-processing or optical filtering. This problem is not encountered with older lower resolution and less sensitive MOS (metal oxide semiconductor) technology cameras. The problem is also less pronounced, but not eliminated, with the newest enhanced dynamic range interline-transfer cameras. The problem is not observed in infrared cameras, both pyroelectric (room temperature) or cooled

technologies (MeCdTe, InSb, or PtSi) which detect black-body infrared radiation from the object rather than reflected visible light.

In Figure 15, a typical night (low light) highway image acquired using the Burle camera (Camera 2) is shown. This image was acquired in color, but almost no color can be seen in the digitized video frame. Intensity-based detail in the image remains very clear, but most color information is lost at low light levels. The additional chromatic information provided by a CCD color video camera is considered to be of significant value for vehicle delineation, not only as a vector component, but as a potential mechanism for discrimination of a vehicle from its shadow. Rejection of shadow effects by the computer vision system is critical for accurate measurements of vehicle dimensions such as length or width. Color may be useful in this respect because a shadowed area in a scene usually is represented in video as having reduced intensity (I) but no change in color hue (H) and only a small change in color saturation (S). The transformation of native NTSC composite or RGB encoded information generated by a color frame grabber into HSI components facilitates this improved ability to distinguish a vehicle edge from its own shadow or the shadow of another object in the scene. While color is advantageous for both shadow-discrimination and as a characterizing component of the VSV, color cameras are typically at least 10dB lower in sensitivity compared with monochrome cameras, and are typically twice as costly. We have observed that even low-cost color cameras possess adequate sensitivity to provide an intensity (I) image of a vehicle in reduced light. However, chromatic (H and S) information is lost at low light levels. Color is not detectable below some minimum illumination level, which is inversely proportional to the product of the aperture and integration time of the camera.

For Phase 2, we tested recently available high-dynamic-range color cameras from Hitachi, Sony, Cohu, Pulnix, and Burle, which are designed to have an extremely wide dynamic range. Improved dynamic range assures that the CCD array remains out of saturation, even for points of high intensity. This eliminates or reduces vertical or horizontal smear. Cameras in this class could be expected to detect color under lower light conditions. This would reduce or eliminate what we estimate to be the greatest source of potential errors in the generation of an accurate and repeatable VSV using computer vision.

After carefully screening, we found that in all cases, the improved dynamic range is achieved at the cost of increased integration time, thus unacceptably long shutter speeds for this application. Consequently, we selected moderately-priced medium-performance color CCD cameras for the computer vision systems developed in Phase 2.

V2SAT Intrinsic Performance Analysis – Travel Time Estimation

At the request of the contract monitor, we assessed the ability of the Loragen V2SAT system to predict travel times based upon Phase 1 field video data. A 17 minute period of traffic flow was evaluated under LOS B on highway 101 in San Luis Obispo, between approximately 8:30 and 8:50 AM. Detectors were located above the number one lanes on the Santa Rosa and California Street overcrossings, which are separated by 0.34 miles. Traffic direction was southbound, making the California site the first site encountered.

Evaluation Limitations

There were some limitations imposed by using prerecorded data. It is not possible to start the play back of both segments of video to achieve exactly the same alignment as would be seen during system operation with live video feeds. There are three reasons for this. The first is that the recording of the traffic at both sites was not started at exactly the same instant. The second cause is that the replay of the tapes will not be started exactly in synch, exacerbated by the fact that our two VCRs are different models with substantially different “spool-up” times. Third, the time bases for each tape were independently generated using internal camera sync signals, which are known to vary a small amount.

To reduce these effects, we added linear SMPTE time code to the audio tracks of both tapes via an audio dub process. This provides a frame number signal on both tapes, although the relationship between the time code and real time is only as accurate as the camera sync signals at both sites. All hand calculations of travel time use this time code for travel time measurement. The tapes are then approximately aligned for replay into two V2SAT detection systems, each communicating with a common correlation computer. With careful coordination in restarting the videos simultaneously, the error in tape alignment was minimized. Given the setup used and experience with the equipment, we expect the alignment error to be within 30 frames or one second.

Video used for this test contained visual artifacts due to sunlight reflections from windshields and hoods, and both vehicular and stationary (bridge and road sign) shadows. The morning lighting conditions were far from ideal, and might be considered representative of a typical real V2SAT deployment. These visual artifacts were found to be the primary source of errors in the computer-vision generated video signature vectors. Their effects are expected to be greatly diminished if an external source of consistent illumination were available, such as the proposed synchronized infrared flash unit.

Hand Calculation of Travel Times

We obtained via hand measurement and calculation an estimated average travel time over all vehicles that actually were present at both site one and site two. Note that both an onramp and offramp were present between the two test sites, and that we recorded video for only one lane of a two/three lane (each way) highway at each site. Thus, of 113 vehicles present at site one and 130 vehicles present at site two, only 96 were present at both locations. Each tape was processed separately. The tapes were lined up to a point a few seconds before the first vehicle in each set. This vehicle, a dark truck with white camper shell, appears at time code 1:22:21:10 and 1:22:37:15 for California and Santa Rosa respectively. Then the tape was paused for each vehicle entering the scene. Human response time placed the vehicle about 3 to 4 frames off screen. Because time code is only generated when the tape is rolling, there is no way to reverse the tape and get the exact time code when the vehicle is centered in the screen. However, careful checking ensured that each car was approximately four frames off-screen. In cases of a miss, the tape was reversed and then paused again as the car passed through. Thus the time code recorded for each vehicle at each site is actually the time code for the vehicle approximately 4 frames off screen. Since this method was used at both sites, the travel time calculations are unaffected by this slight time shift.

Once the tape was paused, the time code was recorded as well as a brief but adequately detailed description of the vehicle. Each vehicle was given an increasing identification number. Note that vehicle

numbering for each site was independent, such that vehicle number X at Site 1 is not necessarily the same as vehicle number X at site 2. Once the data was taken from both sites, the two descriptive lists were matched by hand, identifying just those vehicles that were actually present at both sites. Questionable matches were verified by replaying the tapes and visually comparing the two vehicles in question. The hand-correlated results were entered into a spreadsheet and the final counts, reported below, were calculated.

Hand-Measured Results

Site 1: California overcrossing

Total number of vehicles: 113
Number seen at site 2: 96
Number not seen at site 2: 17

Distribution of vehicle types:

Total number of trucks: 37
Total number of SUV/Minivans: 17
Total number of cars: 55
Total number of other vehicle classes: 4
Total number of vehicles with color information: 55
Total number of vehicles without color information: 58

Site 2: Santa Rosa overcrossing

Total number of vehicles: 130
Number seen at site 1: 96
Number not seen at site 1: 34

Distribution of vehicle types:

Total number of trucks: 40
Total number of SUV/Minivans: 18
Total number of cars: 64
Total number of other vehicle classes: 8
Total number of vehicles with color information: 56
Total number of vehicles without color information: 74

Notes:

- Class labeled "cars" includes hatchbacks, sports cars and station wagons.
- Minivans and SUVs are grouped together because they are usually indistinguishable when viewed from above.
- Vehicles without color information include black, white, gray and silver cars.

Using the time code (uncorrected) from both tapes, the average travel time for all vehicles observed at both sites during the 17 minute period was 18.17 seconds. We measured a separation between sites of 1800 feet by timing the transit time of a test vehicle traveling at a constant 65 mph speed (determined by the vehicle's speedometer). This separation yields an average speed of 67.54 miles per hour, with the fastest travel time of 12.7 seconds (96.4 miles per hour); and the slowest travel time 22.4 seconds (54.7 miles per hour). The speed limit on HWY101 through San Luis Obispo is 65mph. We are aware that the speedometer of the test vehicle probably reads higher than true, which means that the separation was actually less than 1800 feet and all actual travel time figures were correspondingly high. This skew effects both hand calculated and V2SAT-computed travel time averages equally.

V2SAT Computed Results

The following results were obtained by replaying both tapes simultaneously into the detectors of V2SAT system, with vector matches and travel time calculations determined in real time by the correlation computer. (This setup simulates the actual deployment of the system on the highway.) The figures listed below were calculated by comparing the V2SAT output results with the actual hand obtained information.

The following definitions apply:

Correct match (C): A vehicle that actually passed through both sites was detected at both sites, and the vectors generated for it at each site were determined to be matches by the correlation computer.

Missed match (M): A vehicle that actually passed through both sites was not matched based on its vectors.

Wrong match (W): A vehicle was matched with a different vehicle at the other site

Impossible match (I): A vehicle at the second site was matched with a vehicle from the first site that did not originate from the first site (changed lanes or entered via onramp).

Site 1 California:

Number of vehicles detected: 113

Number of vehicles not detected: 0

Site 2 Santa Rosa:

Number of vehicles detected: 130

Number of vehicles not detected: 0

Total V2SAT matches: 84

(C) Number of vehicles correctly matched: 78

(M) Number of missed matches: 15

(W) Number of wrong matches: 3

(I) Number of impossible matches: 3

Percentages:

Percent correct matches out of all computed matches: 92.86%

Percent correct matches out of all possible matches done by hand: 81.25%

Percent "No Matches" made correctly: 88.23%

Average V2SAT-calculated travel time: 18.04 seconds

(This travel time includes the effects of all incorrect matches, the error associated with misaligned tapes, and quantization error which limits time measurement precision to one second.)

This yields an average travel time which differed by 0.715% from the hand calculated values.

Phase 2 Computer Vision Algorithm Development

Under Phase 2 (Task A) we investigated algorithms for non-intrusively tracking individual vehicles on freeways for data collection purposes. The functional objective was to mechanize in real-time code the optical measurements made on each vehicle image, as was done manually in Phase 1. As in Phase 1, a conventional color video camera serves as the primary sensor in a self-contained detection module including a dedicated image processing computer and wireless communications components. The image stream from this camera is digitized on a field-by-field basis at 60 fields per second, the full EIA 170 specified rate for loss-less video. The digitized images of each passing vehicle are processed by the computer code to generate the Video Signature Vector (VSV), which is transmitted over the wireless network to a central correlation computer. The correlation computer continuously receives VSV's asynchronously transmitted by all detection modules, attempts to match VSV's to re-identify each vehicle at each detectorized site, and maintains statistics on traffic flow and successful matches.

Phase 2 utilizes data and conclusions from Phase 1 work, completed in 1997. Limitations of the method were identified: adequate ambient lighting was required for accurate detection, and image artifacts such as shadows could be problematic in a computer vision mechanization of the method.

Phase 2 Task A focused upon the development of computer vision algorithms for detection of the VSV and correlation between successive sites. The following design decisions were made during early Phase 2 work, benefiting from Phase 1 observations:

1. We examined several methods for robust **detection of the optical features** that constituted the VSV components. Algorithmic tasks included background generation by temporal IIR filter operating on individual pixels in user-selected detection window, identification of true vehicle centerline, feature extraction from vehicle images using a spatial recursive filter, N-deep edge detection, and a modified directional derivative. Several experimental means for enhancement of information-to-noise ratio and rejection of image artifacts have been developed and tested. These include:

a. Ensemble averaging of successive video fields containing images of vehicle (originally proposed), alignment by speed extrapolation, sum of error products (SEP), or both. This was found to be best for rejection of transient image artifacts, but subject to unacceptable geometric (animorphic) aberration that ultimately made this averaging method unusable.

b. Synthetic aperture vehicle image extrusion. This method uses a detection band through center of window. It is a sampled data approach – slices of vehicle image are connected artificially. This was found to be the best means to eliminate geometric aberration, but subject to problems related to variable vehicle speeds (especially very slow cars) since connection of overlapped slices between fields is required for the synthesis of the synthetic aperture image.

c. Single-image "flash" analysis. This relatively simple method duplicates the manual means for vector extraction used in Phase 1 work. We track the front of vehicle and freeze the last full vehicle image before the front end leaves the window. Only this last image is analyzed. This approach eliminates the problems of aligning multiple vehicle images with different degrees of geometric animorphic distortion, allowing us to use camera height correction only (as in Phase 1). However, it lacks a mechanism for identification and rejection of transient or stationary image artifacts, yields vectors with possibly more clutter.

Design decision: Single image analysis seemed the best overall compromise, since it avoids geometric registration problems, despite the loss of the ability to do ensemble averaging for rejection of artifacts.

We have concluded that the problems associated with the exclusive use of ambient lighting are the main limiting factors effecting accuracy. This almost completely precludes the use of the system at night or under conditions of harsh shadows that subdivide the vehicle. Among the potential solutions which we propose for future work are a high power pulsed VNIR illuminator which is activated upon detection of the

vehicle (via ambient illumination) in the detection window. The required IR power output of the illuminator as currently designed is approximately 200 Watts during each 1 millisecond pulse (one pulse per vehicle). The average energy dissipation of this illuminator is small. The illuminator functions as a fill-flash (reducing shadows) during daylight operation, and as the primary source of illumination during night operation. The existence of this external illumination source greatly reduces the difficulty of repeatably generating the VSV at each site.

2. We examined the **packaging and communication of the VSV** from detection modules to the correlation computer. The issues we studied were:

a. Vector format

- Text or binary information formats were studied.
- Fixed or variable vector length limit.

b. Communications between detection modules and correlation computer:

- Virtual hard-wired serial stream
- Network communications.
- Fixed vs. variable packet length.
- Socket communications (continuous connection) or burst broadcast.

c. Communications media.

- Wireless modems using commercial ISP (MetriCom).
- Local wireless network (wireless network cards).
- Dedicated packet radio.

Design decision: The most cost effective means for detector/processor communications is socket-based Ethernet communications over wireless modems. We have used a commercial wireless Internet service provider in the San Luis Obispo Area, MetriCom Inc., which offers continuous 33 KB wireless network connectivity at a cost of \$30 per month per channel. We have fully implemented and tested the socket-based communications protocols over a hard-wire LAN at the Loragen facility.

3. We examined several **algorithms for correlation of VSV** between consecutive sites.

a. Front-aligned Average Absolute Error (FA3E) – method used for hand-analysis in Phase 1 preliminary work. Simple and repeatable, but makes all longitudinal measurements with respect to vehicle front end, which must therefore be accurately detected in all cases.

b. Normalized Sum of Error Products (SEP) alignment and correlation error generation. Eliminates the requirement that the front end of each vehicle be accurately detected, but computationally much more demanding.

c. Feature-optimized correlation:

- SEP optimal alignment of features
- Annihilation of orphan features
- Normalized SEP on equal-feature pair and/or FA3E for generation of final correlation error.

Design decision: Option (c) produces best results, since it utilizes SEP for best vector alignment and FA3E for actual vector correlation.

4. We developed a full-featured **correlation computer software package**. Functions include:

a. Network communications (socket-based). Internet-based communications with detection modules. External internet-based access and control possible.

b. Correlation engine with multiple correlation algorithms for experimental validation.

- c. Database generation – generates match/no-match statistics
- d. Graphical operator interface.

Design decision: Most effective using network-based socket communications between detection modules and correlation computer. Adaptive thresholding based upon average background noise level at site pairs. Revision 1 operator interface displays bitmap images of matched vehicles for operator confirmation during testing.

Summary of V2SAT Phase 2 Algorithm Development (Task A)

Examined several methods for creation of Vehicle Signature Vector (VSV):

Algorithm steps were:

Temporal IIR filter in window.

Feature (discontinuity) extraction by each of three methods:

- a. Spatial recursive filter.
- b. N-deep edge detection.
- c. Modified directional derivative (combined IIR filter and first order differential).

Enhancement of information-to-noise ratio and rejection of image artifacts (such as shadows or reflections on vehicle):

- a. Ensemble average images of vehicle from each field (originally proposed). Alignment by speed extrapolation, sum of error products (SEP), or both. Best for rejection of transient image artifacts by subject to unacceptable geometric (anamorphic) aberration
- b. Synthetic aperture vehicle image extrusion. Detection band through center of window. A sampled data approach – slices of vehicle image connected artificially. Problem with connection of overlapped slices between fields due to dependency on vehicle speed.
- c. Single-image “flash” analysis. Track front of vehicle until last full image before leaving window. Analyze only this last image. Eliminates problem of aligning multiple vehicle images with different degrees of geometric anamorphic distortion. Use camera height correction only. Emulates hand-method used in Phase 1 preliminary analysis. No mechanism for identification and rejection of transient or stationary image artifacts and uncertain. Yields vectors with possibly more clutter.

Examined Packaging and Communication of VSV to Correlation Engine/Server:

- 1. Vector format
 - a. Text or binary information format.
 - b. Fixed or variable vector length limit.
- 2. Communications between detection modules and correlation computer:
 - a. Virtual hard-wired serial stream

- b. Network communications.
 - Fixed vs variable packet length.
 - Socket communications (continuous connection) or burst broadcast.
- c. Communications media
 - Wireless modems using commercial ISP (Metricom / Richocet).
 - Local wireless network (wireless network cards).
 - Dedicated packet radio.

Examined several algorithms for correlation of vehicles between consecutive sites:

1. Front-Aligned Average Absolute Error (FA3E) – method used for hand-analysis in Phase 1 preliminary work.
2. Normalized Sum of Error Products (SEP) alignment and correlation error generation.
3. Feature-optimized correlation:
 - a. SEP optimal alignment of features
 - b. Annihilation of orphan features
 - c. Either: Normalized SEP on equal-feature pair or FA3E for generation of final correlation error.

Software on Correlation Engine/Server

Developed correlation computer software package, including:

- Database generation – generates match/no-match statistics
- Graphical operator interface.
- Experimental and Developmental Observations

Developed network communications (socket-based), and Internet-based communications with detection modules.

Implemented external Internet-based access and control.

Developed and compared multiple correlation algorithms for experimental validation:

- Get position of vehicle and centerline/average all frames (color and b/w)
- “Bockify” the entire car and send all blocks (color and b/w)
- SAR (b/w)
- Single frame of car close to camera (b/w)
- A few frames of car close to camera averaged (b/w)

Developed, studied and compared several vector alignment methods:

- Front position

- Front and Speed of vehicle
- Mathematical summation minimization method

Developed and compared several methods for vehicle front end detection:

- Center dot & summation of noise
- Squeeze car along edge
- Scan all for front of vehicle

Studied several methods for spacial differentiation:

Averaging horizontal and vertical pixels

Std differentiation

IIR filtering first, then differentiate

IIR filter after, then differentiate

Filter and IIR (including current field) during differentiation

Problems encountered:

Vector alignment

Skewing due to camera angle and differing feature heights

Shadow rejection

Sun glint off features (vertical smear)

False triggering (entry and exit)

Image noise due to passing vehicles in nearby lanes

The VSV Generation Program (v2sat.exe) Running on Each Detection Computer

The data acquisition program is used to monitor traffic flow and develop a VSV information vector for each vehicle passing through the window of interest. The information vector contains the time at which the vehicle was acquired, the lane the vehicle is in and some physical measurements of the vehicle. The physical measurements include the width of the car and the measurements to the major inflection points along the vehicle such as the hood, top and bottom of the windshield, etc.

Camera placement and aiming was found to be critical to achieving reproducible vectors. The detailed camera setup procedure is described in the Appendix. Figure 16 below shows the camera view when properly positioned.

From a user point of view, the program consists of six distinct windows. One window is used to relay messages and warnings to the user. Two windows are utilized for the user to manually adjust the operating perimeters of the program. There is a window for viewing the current processed results, an

initialization window shown when the program is first run and a main window, which is usually the window in focus during normal operation.

These six windows all compose a single thread of operation. This program actually operates with two threads of execution. The thread that contains the user viewable windows is used to collect images of cars passing through as well as obtain information from the user. A second thread (which can be thought of as another program running concurrently) is used to view the images saved by the first thread and develop a vehicle information vector.

A multithreaded model was used to allow for maximum utilization of the processor for both data acquisition and processing. The act of processing the images or saving images into memory is processor intensive and time consuming. Attempting to acquire an image and then process that image before the next image is available would allow for only a small fixed window of time in which to perform all desired operations. If the processing took only slightly too long, the next image would be missed. In the multithreaded model a high priority thread is used to acquire the images, assuring that all necessary resources are available to handle the data acquisition. As data is acquired the images are put into a circular buffer to be processed at a later time. A lower priority thread is used to process the acquired data; this allows the data processing to occur in the gaps in which the primary thread is idle.

In order to detect a vehicle in the window of interest, the program needs to first develop an average background image to which the current images can be referenced. When the window of interest is first selected, the current image within the window is saved as the background image. This background image is then updated with each successive image (only those without vehicles are used for this purpose). The method used to update the background image is an Infinite Impulse Response (IIR) filter used on a pixel by pixel basis. This is accomplished by adding a small percentage of the current pixel value to a larger percentage of the corresponding background pixel value. Both percentages should total unity. Persistent changes in the background can be compensated while ignoring any transient changes in the image.

Vehicle detection is accomplished by monitoring a four by four square of pixels along the side of the window where vehicles enter into view. As each field of the image is acquired, the difference in these sixteen pixels compared to the corresponding pixels in the background is calculated. If the difference exceeds the adaptive threshold a vehicle entry is detected.

The adaptive threshold is developed from three detected values. In images without vehicles, the difference between the current image and the background image (over the sixteen pixel square) is calculated. The average difference level and maximal and minimal difference figures are calculated from this difference. These values are measurements of how noisy the image is without a vehicle in the scene.

The average difference is calculated via an IIR filter with a coefficient of .25 for the current data. This allows the noise average to follow the current noise value rather well and still remove any large noise spikes. The maximum and minimum values are calculated by increasing (or decreasing) the figure rapidly if the current noise exceeds (or lags) the current value. Otherwise the figure will slowly decay toward the average. In this fashion the two figures will create an envelope around the noise data. The adaptive threshold is calculated by adding three times the difference between the maximum and minimum values to the noise average.

This process is repeated for both sides of the image to develop separate adaptive thresholds for the left and right sides. One is used for entry detection while the other is used for exit detection. In this manner, changes in environmental conditions from one side of the scene to the other can be compensated.



Figure 16. Example of Proper Camera View and Detection Window Placement.

Once a vehicle entry is detected, backgrounding and filtering are stopped and images are saved into buffers to be processed later. Once the car is detected on the exiting edge of the image the process of saving images is stopped. Once the car has completely left the scene (no more exit detection) the process of entry detection and backgrounding is resumed.

Each image buffer contains additional information other than the image itself. Included in each buffer are both the left and right side adaptive thresholds, the time the image was captured, the vehicle number, the image count (per vehicle), the field number and the coordinates of the box drawn over the image and some data to keep track of buffer usage. The vehicle number is an absolute count starting at 1 for the first vehicle that is detected from program execution. The image count is a consecutive count starting at 1 for the first image field saved for each vehicle. The count increments once for every field captured regardless if the image was saved or not; thus missed images can be detected and compensated. The field count designates field 0 or 1 of the image. For standard EIA170 video, image frames are interlaced; this means that for every whole image frame there are two corresponding fields. A field covers half of the horizontal scan lines of the image. Field 0 covers the even scan lines while field 1 covers the odd scan lines of the image. The frame rate is 30 frames/sec, thus the field rate is 60 fields/sec. This means that there is 1/60 of a second between successive field captures. This obviates processing fields rather than frames. The vehicle will move a substantial distance in 1/60 second and the resulting image frame will appear to be two overlaid images of a vehicle at substantially different locations on the road. Processing on an individual field basis removes problems associated with the motion of the vehicle between acquisition of the two fields that compose the single image frame.

The primary thread's responsibilities end with saving the appropriate images and information into buffers. The secondary thread will then process the data in the buffers and produce the desired information vector for each vehicle detected by the primary thread.

The vehicle and image count values are monitored to detect the end of one vehicle and the beginning of the next. For every image frame of a single vehicle an eight pixel wide strip down the center of the car is examined (from one end of the image to the other) and the inflection points of the image along this strip are recorded. Inflection points are regions where the intensity of the image changes substantially. These changes are caused by transitions such as from pavement to bumper and hood to windshield. The procedure for detecting inflection points is a three-step process. First the eight pixel wide strip down the center is averaged and low-pass filtered. This process is used to reduce the effect of noise on the measurements. The averaging is done over the eight pixels vertically aligned and the sum is then low-pass filtered via an IIR filter.

The result is a single pixel wide line the same length as the window of interest. The second step in processing is to differentiate the filtered line to produce spikes designating changes in intensity. The differentiation would normally be accomplished by recording the difference between any given pixel and its predecessor (as the line is traversed from one side to the other). In an effort to further remove any effects of noise on the result, a second filter performed concurrently accompanies this differentiation process. Instead of differentiating with respect to the previous pixel, the differentiation is performed with respect to the value calculated from another IIR filter. The difference here is that this filter takes into account the current pixel being differentiated as well as the previous pixels. This has the effect of both reducing the effect of noise and removing small features such as cracks in the pavement.

Once the differentiation is accomplished, a threshold is applied to the results and the peaks of the regions that exceed the threshold are recorded as the major inflection points of the image. This threshold is simply one half of the maximum value of the differentiated data. The results of this process for each of the images of each vehicle are stored until the last image of a vehicle is processed.

After the inflection points from last image of a vehicle are calculated the inflection point vectors must be lined up so that the common characteristics can be determined. The matching process is performed on only two lines at a time. The process starts with the first two vectors calculated. The number of pixels the first vector needs to be shifted to match the second vector is recorded with the data for the first vector. The process is then repeated for the next two lines (in this case, vectors 2 and 3). In this manner every

vector contains the information to align it to the next vector. The only vector without alignment data is the last vector because all the other vectors are aligned to it.

Figure 17 illustrates a set of typical centerline intensity profiles aligned and processed via this method. The two more similar traces (squares and diamonds) represent vectors from the same vehicle, generated at different sites. The trace with triangle data points was generated by a different vehicle.

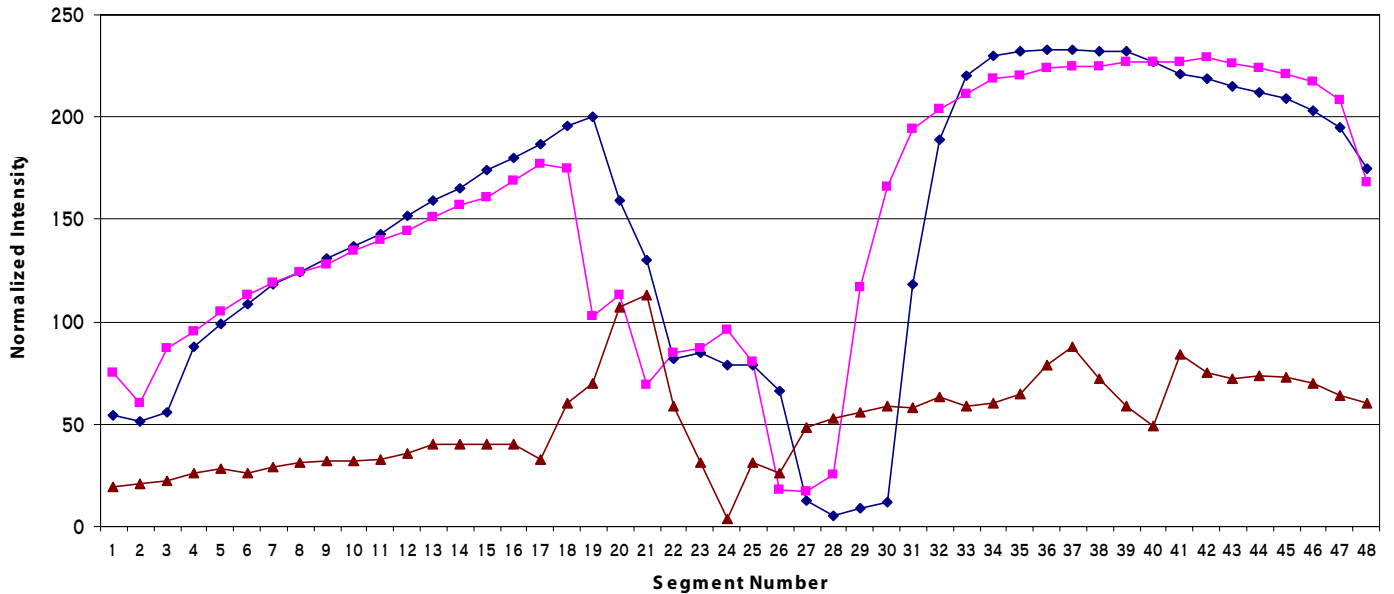

Figure 17. Normalized 48-Segment Centerstripe Intensity Profile: Comparison of Correct Match with Incorrect Match.

Vector alignment is performed as follows: The vector occurring further ahead in time (the second vector) is held still while the previous vector (the first vector) is shifted. For every position, until the last pixel of the first vector passes the first pixel of the second, a calculation is performed to measure the amount of correlation between the two vectors. The correct alignment is the amount of shift to achieve the lowest result (the best correlation). The correlation calculation is accomplished by summing the products of the lengths from every point in vector one to every point in vector two.

Once the correct alignment is determined another vector is formed by combing all the aligned vectors into a single vector. This vector will have large spikes where multiple inflection points lined up but only small point where a single noise spike managed to be recorded. In this fashion another layer of noise rejection is added. A threshold is then applied to this summed vector and the larger spikes are recorded as the measurements along the length of the vehicle. A block diagram of the detection algorithm appears in Figure 18 below.

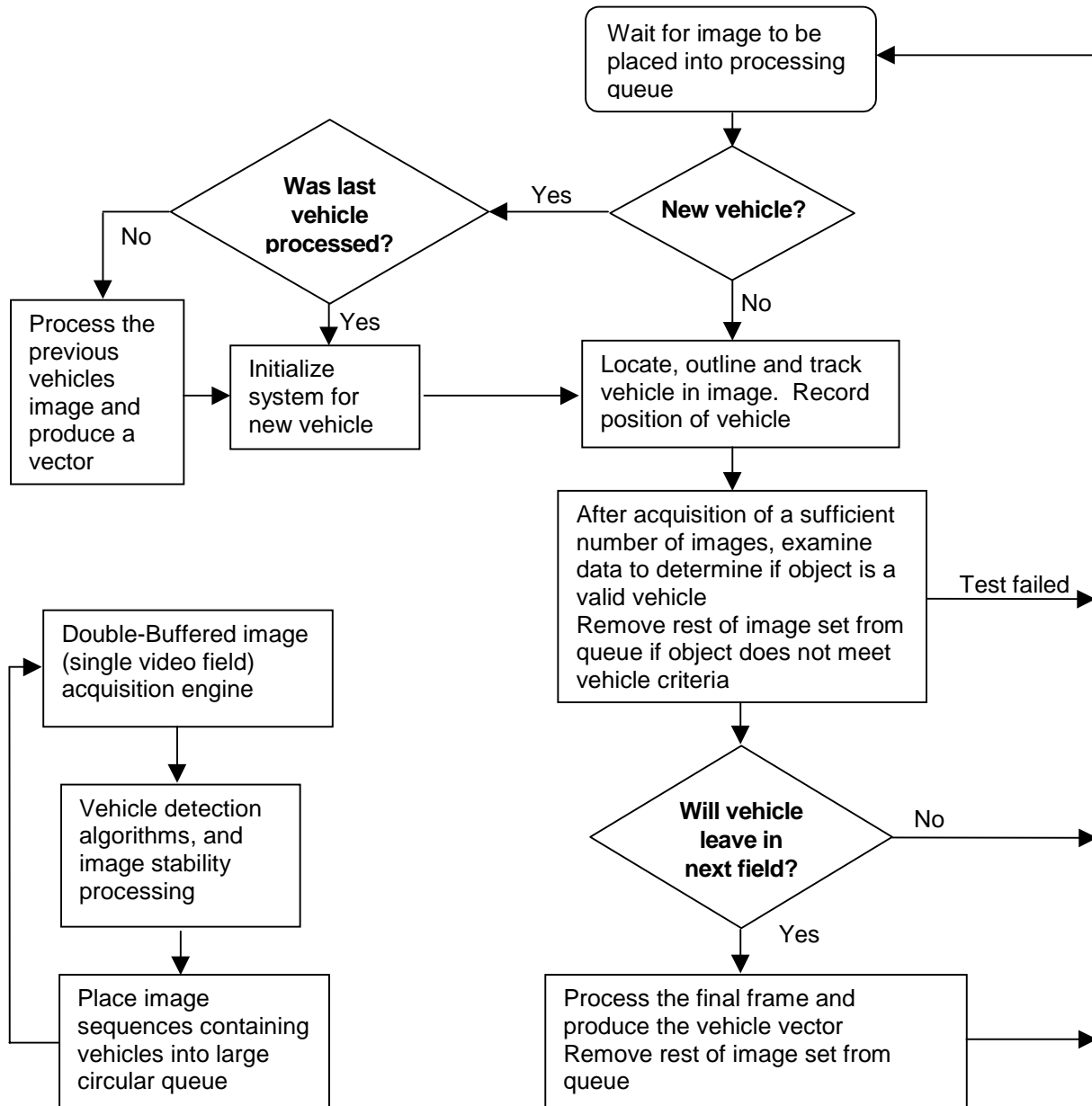

Figure 18. Detection Algorithm Block Diagram

A screen shot of the detection module user interface appears in Figure 19 below.

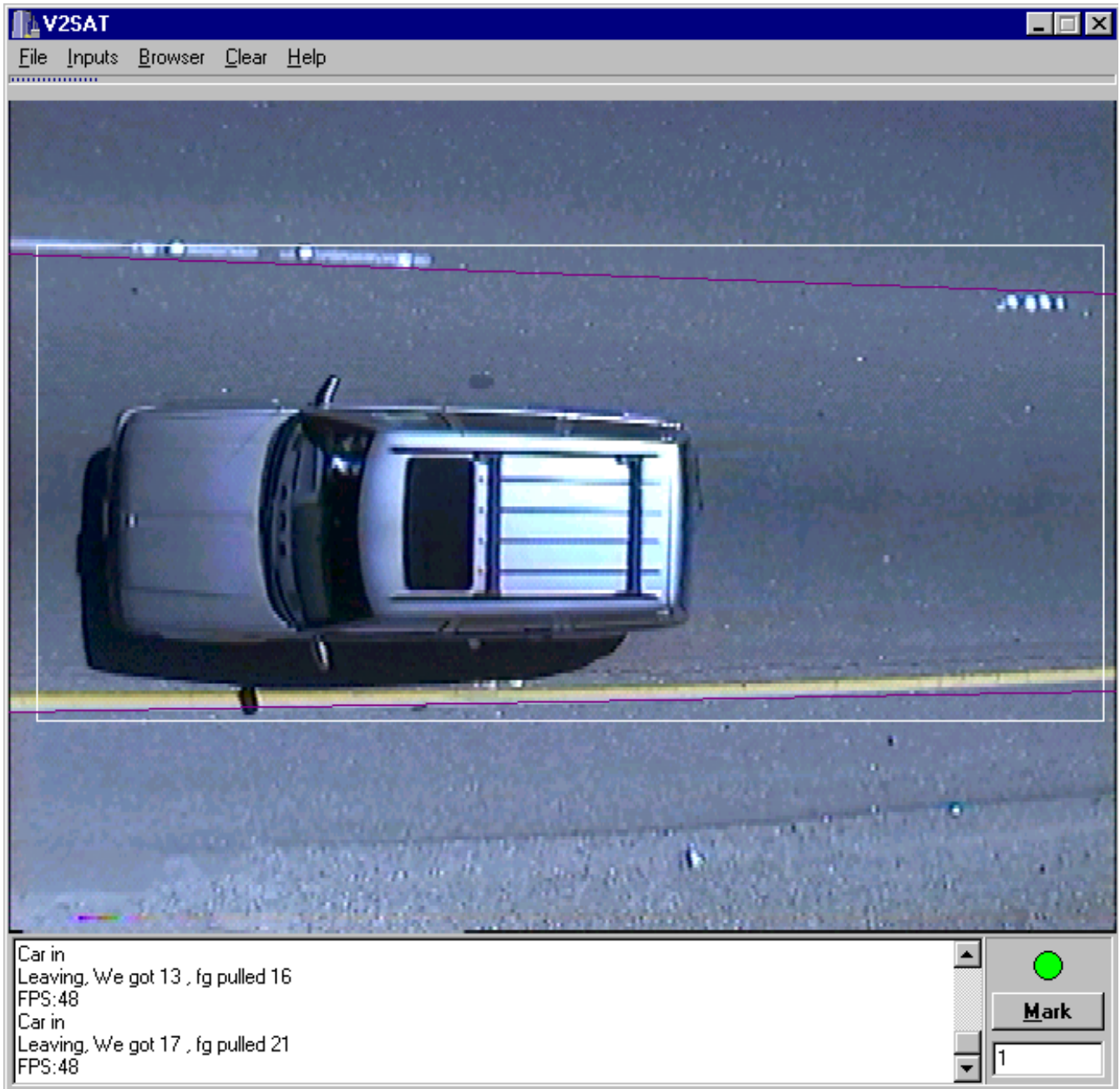

Figure 19. Detection Module User Interface.

The Vector Correlation Program (Correlation Engine)

The data correlation program takes sets of vehicle data vectors from two sites and attempts to match vehicles between sites. The first step in matching vectors is to limit the set of vectors to compare to the set of vectors within a reasonable time window. With a known distance between the two sites a reasonable time window can be calculated by dividing the distance by a maximum and a minimum speed.

Then a correlation calculation is performed on the vector to be matched and every candidate vector from the next site. The pair of vectors with the lowest result (the best correlation) is the matching vehicle. Included is an absolute lower correlation threshold, which allows "no match" conclusions to be made for vehicles that were not actually present at both sites. (entered or exited the freeway between sites, or stopped on the side of the road).

Composite error calculation for each vector pairing:

$$e = 100\% \cdot \frac{\sum_{j=1}^7 |X_j \cdot W_j \cdot C_j|}{\sum_{j=1}^7 (W_j \cdot C_j)}$$

(j^{th} vector component)

Where:

X_i = normalized individual component error figure (0.0 to 1.0)

W_i = component weight in final decision (0.0 to 1.0)

C_i = confidence factor for component (0.0 to 1.0)

Error components (X_i):

Overall length difference (if available)

Width difference (if available)

Average hue difference, weighted by saturation

Average differential intensity

Time of arrival relative to prediction from average velocity

Relative lane position

Intensity profile differential area, via fuzzy rule base

A simplified flow chart for the correlation process is shown in Figure 20. A screen shot of the user interface for the correlation engine is shown in Figure 21.

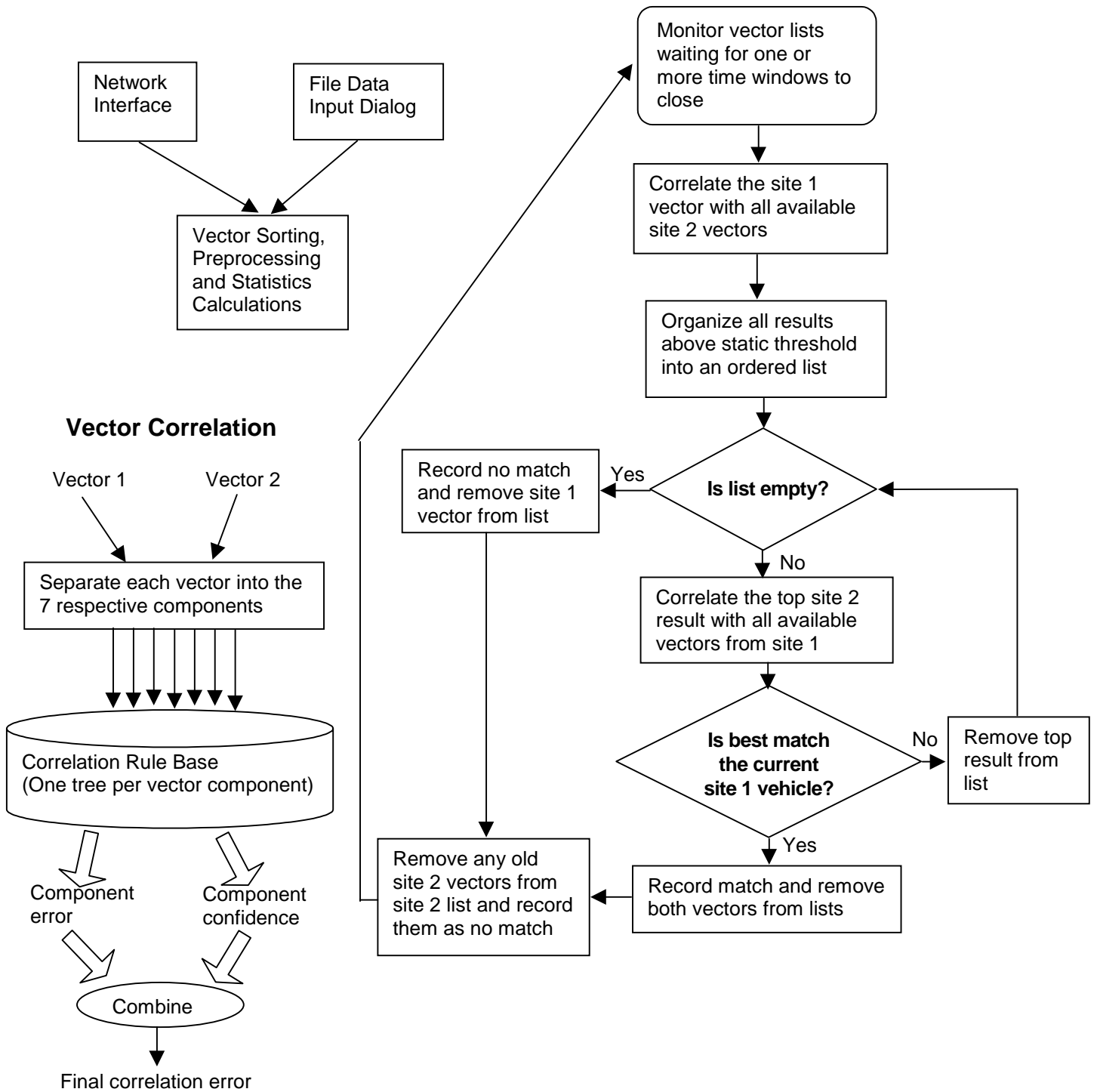

Figure 20. Flow chart for Correlation Processing Code.

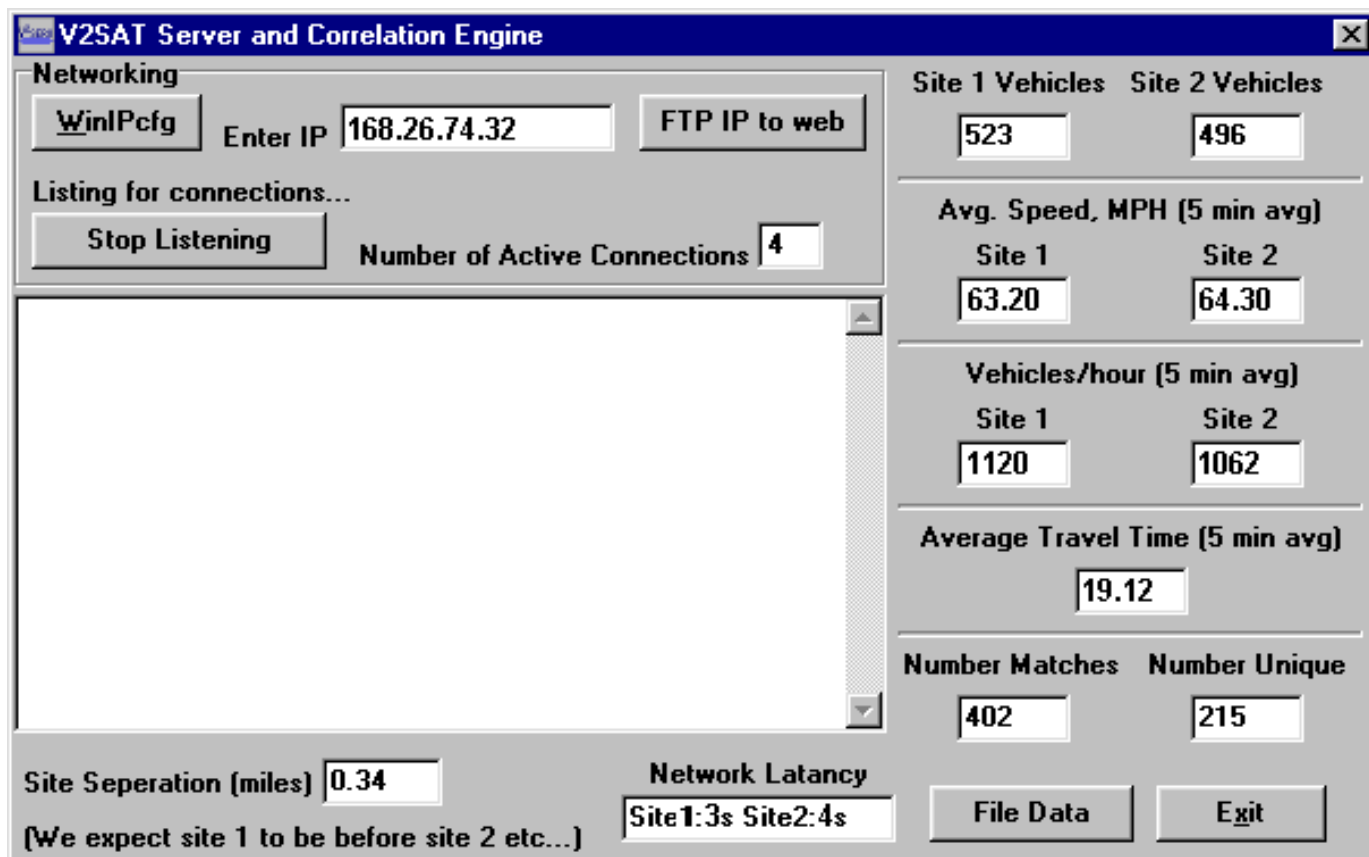

Figure 21. Server / Correlation Engine User Interface.

V2SAT System Test & Verification Procedures

The following procedures were used to test and verify the performance of the V²SAT system. While the system operated in real-time and acquired live traffic data, video tapes were acquired in parallel from the camera feeds for purposes of off-line verification. These video tapes were manually processed to determine an absolute record of correctly matched vehicles at successive sites. Data generated by the system, in terms of reported matches, were compared off-line with these reference records on a vehicle-by-vehicle basis.

Step 1: Verification of Vector Acquisition

The goal of this step is to calculate the percentage of vehicles missed by the V2SAT data acquisition engine. This is calculated by stepping through the recorded video footage and comparing each passing vehicle with the recorded images saved by V2SAT. The video is best viewed with a VCR that has shuttle advance and the *.V2S images from V2SAT must be viewed with V2VIEW.EXE. This will be done four times, once for each site and lane combination. If a vehicle appears in the video but not in the set of images saved by V2SAT it is considered a miss. Only vehicles completely in the lane are considered, if a vehicle is partially out of the lane it is not included in the set. The final error percentage is calculated by dividing the number of misses by the total number of vehicles plus the misses [misses / (total acquired + misses) = percent error]. The total acquired vehicle count by lane can NOT be obtained by just looking at the number of the last *.V2S image in the set, since it is possible (likely) that there are numbers (vehicles) missing in the set. The easiest way to obtain the total number of vehicles for any one site is to use the mouse to highlight all the *.V2S files for a given site and then read the number of files that the Windows 95 operating system says are highlighted. This step results in a missed count and percent missed for each lane as well as statistics for all lanes together.

Step 2: Correlation Verification

Now the output of the V2SAT correlation engine must be verified. The correlation program (V2SERV.EXE) has two output files: results.txt and debug.txt. Debug.txt is a real-time dump of all the processing performed by V2SERV during the data run. It provides useful information to determine why a match was missed or a mismatch occurred, but is not needed to verify correct correlation. The relevant file is named results.txt.

Results.txt contains lines with the following format:

Site1Vehicle#,Site1Lane# : Site2Vehicle#,Site2Lane# : Average Speed : Vector Error

This data line contains four fields, one for the Site 1 vehicle and one for the Site 2 vehicle, as well as the Average Speed and Vector Error fields. The last two fields are mainly for debug purposes and can be ignored for this test. If there is a match the site 1 and site 2 fields will contain valid data (numbers), to report "no match" only one site field will contain numbers and the other field will be X'd out (X,X).

Example 1:

27,1 : 3,1 : 83 : 0.14

This line shows a match between Site 1, Lane 1, Vehicle # 27 with Site 2, Lane 1, Vehicle #3. The average speed at both sites was 83 feet per second and the vehicles correlated with 14% error.

Example 2:

8,2 : X,X : 74 : 1.00

This line shows a "No Match" for vehicle #8 at Site 1, Lane 2. This vehicles speed was 74 ft/s and the error shows 100% because it was not matched.

The results desired from this step are number of missed matches (correlation error) and the number of incorrect matches (cross correlation error). The program used to determine these counts is V2VIEW.exe.

V2VIEW should be used to load images for all four sets of data (both lanes at both sites). The results.txt file should also be opened. Now the results.txt file should be examined one line at a time. If the file reports a match then view both images in V2VIEW and visually verify the match is correct, if the file shows no match then verify that there is not a match in either lane at the other site (within a reasonable time window). For an incorrect match, it also needs to be noted whether or not a match was possible. When finished, missed and incorrectly-matched counts are obtained. Now open debug.txt and go to the very bottom. Read and record the total number of matches and the total number of unique vehicles. Note that Matches + Unique will not equal the sum of vehicles seen at both sites. This is because one match counts for two counts (one at each site) while a unique count is for a single vehicle. Therefore $2 * \text{Matches} + \text{Unique} = \# \text{Site1} + \# \text{Site2}$. Total possible matches can now be calculated by summing the number of matches - number incorrect matches + number of misses + number of mismatches with possible correct matches. The percentage missed can be calculated by dividing the number of misses by the total possible matches. Percentage of incorrect matches is calculated by dividing the number of misses by the number of matches reported in debug.txt.

When complete, the following statistics are reported:

For each site:

1. Number of vehicles acquired
2. Number of vehicles missed
3. Percentage of vehicles missed

For the complete set:

1. Number of vehicles acquired
2. Number of vehicles missed
3. Percentage of vehicles missed
4. Number of correct matches
5. Number of missed matches
6. Number of incorrect matches
7. Percentage of matches missed
8. Percentage of matches made incorrectly

California O.C. Site

Santa Rosa (Hwy 1) O.C. Site

V2SAT Image Viewer
File Options Process <11 11> <12 12> <21 21> <22 22> [464:21] LoadResults Prev Next Skip

I:\9_28_fieldtest\cal2\car0342.v2s Site 2 Lane 2

I:\9_28_fieldtest\san2\car0403.v2s Site 1 Lane 2

I:\9_28_fieldtest\cal1\car0311.v2s Site 2 Lane 1

I:\9_28_fieldtest\san1\car0385.v2s Site 1 Lane 1

Results 288: Match 12 #400 with 22 #341
Results 289: No Match for 12 #401
Results 290: No Match for 11 #384
Results 291: No Match for 12 #402
Results 292: Match 12 #403 with 22 #344
Results 293: Match 11 #385 with 22 #342
Results 292: Match 12 #403 with 22 #344
Results 293: Match 11 #385 with 22 #342

Site Separation: 0.34 Save pair to truth file

Figure 22. Vehicle Signature Analysis: Comparison of Images Processed at Each Detector Site.

California O.C. Site

Santa Rosa (Hwy 1) O.C. Site

The screenshot displays the V2SAT Image Viewer interface. At the top, the title bar reads "V2SAT Image Viewer" and the menu bar includes "File", "Options", "Process", and navigation buttons. The main area is divided into four quadrants, each showing a top-down view of a white car. The top-left quadrant is labeled "Site 2 Lane 2" with file path "I:\9_28_fieldtest\cal2\car0356.v2s". The top-right quadrant is labeled "Site 1 Lane 2" with file path "I:\9_28_fieldtest\san2\car0417.v2s". The bottom-left quadrant is labeled "Site 2 Lane 1" with file path "I:\9_28_fieldtest\cal1\car0313.v2s". The bottom-right quadrant is labeled "Site 1 Lane 1" with file path "I:\9_28_fieldtest\san1\car0385.v2s". Below the images is a text area containing the following results:

```
Results 315: No Match for 22 #350
Results 316: Match 11 #394 with 21 #318
Results 317: Match 12 #414 with 22 #354
Results 318: Match 12 #415 with 22 #355
Results 319: Match 11 #395 with 21 #319
Results 320: Match 11 #396 with 21 #320
Results 321: No Match for 12 #416
Results 322: Match 12 #417 with 22 #356
```

At the bottom of the window, there is a "Site Separation:" field with a value of "0.34" and a "Save pair to truth file" button.

**Figure 23. Vehicle Signature Analysis:
Challenging Vehicle Pairings.**

Field Test Results

The compiled accuracy results of all field tests are shown diagrammatically below. Sites were separated by approximately 0.4 miles, and were highly lossy; that is, many cars detected at site one never arrived at Site 2, and many cars present at Site 1 one did not originate from Site 1. The chosen sites simulated a much larger site separation, with several regular onramps and offramps in between. A data was generated by the system in real time, and verified for accuracy off-line by manual comparison with video tapes recorded from each detection camera.

Each chart below shows the actual traffic flow components present during test periods conducted on different days, morning, noon and afternoon. The data which follow are the results reported by the V²SAT system, compared with the actual vehicle movements during the test period.

Field Test Data 9-2-99 Late Morning

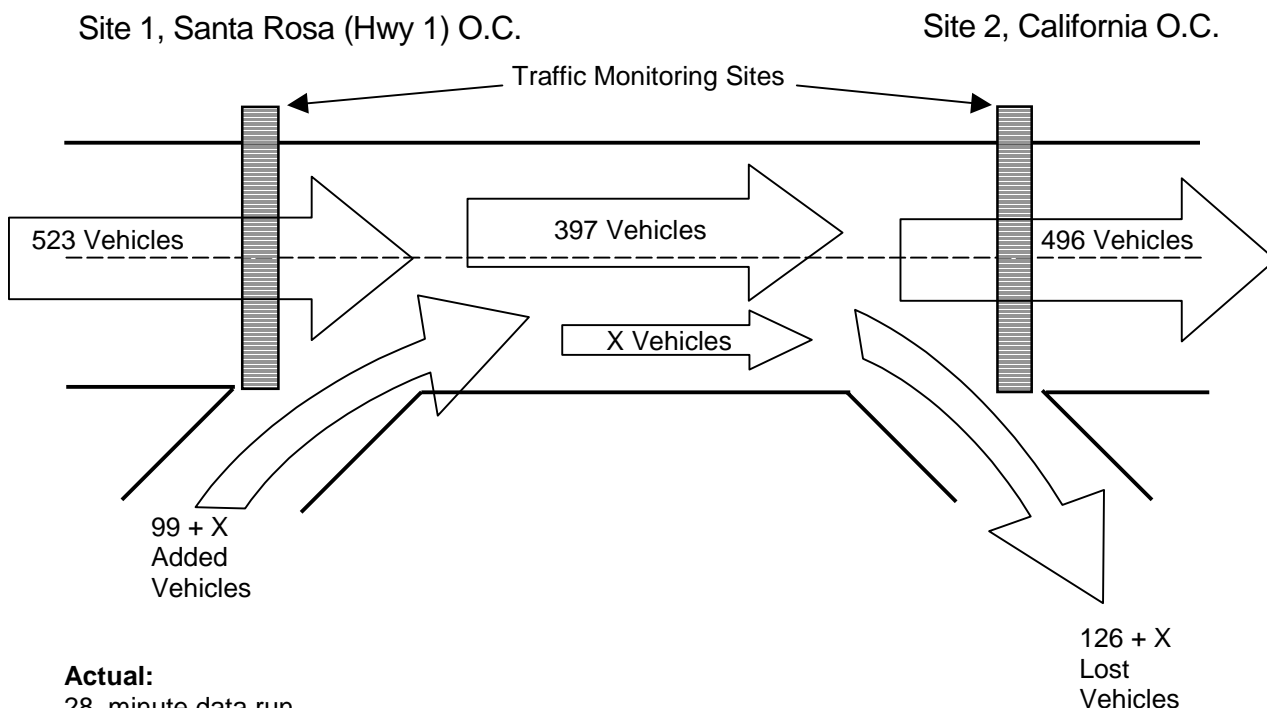

Actual:

28 minute data run
 523 vehicles at site 1
 496 vehicles at site 2
 397 vehicles from site 1 arrived at site 2 (total possible matches)
 126 vehicles from site 1 did not arrive at site 2
 259,408 possible pairings
 259,011 total possible incorrect matches

V²SAT Results:

402 matches reported: 382 correct + 20 incorrect*
 15 failures to match

Normalized Accuracy:

Percent vehicles correctly matched out of total possible matches: 96.2%
 Percent incorrect matches out of total possible incorrect matches: 0.00772%

* Of the 20 incorrect matches, 19 were pairings consisting of one or both vehicles that appeared at only one site.

Field Test Data 9-28-99 Noon

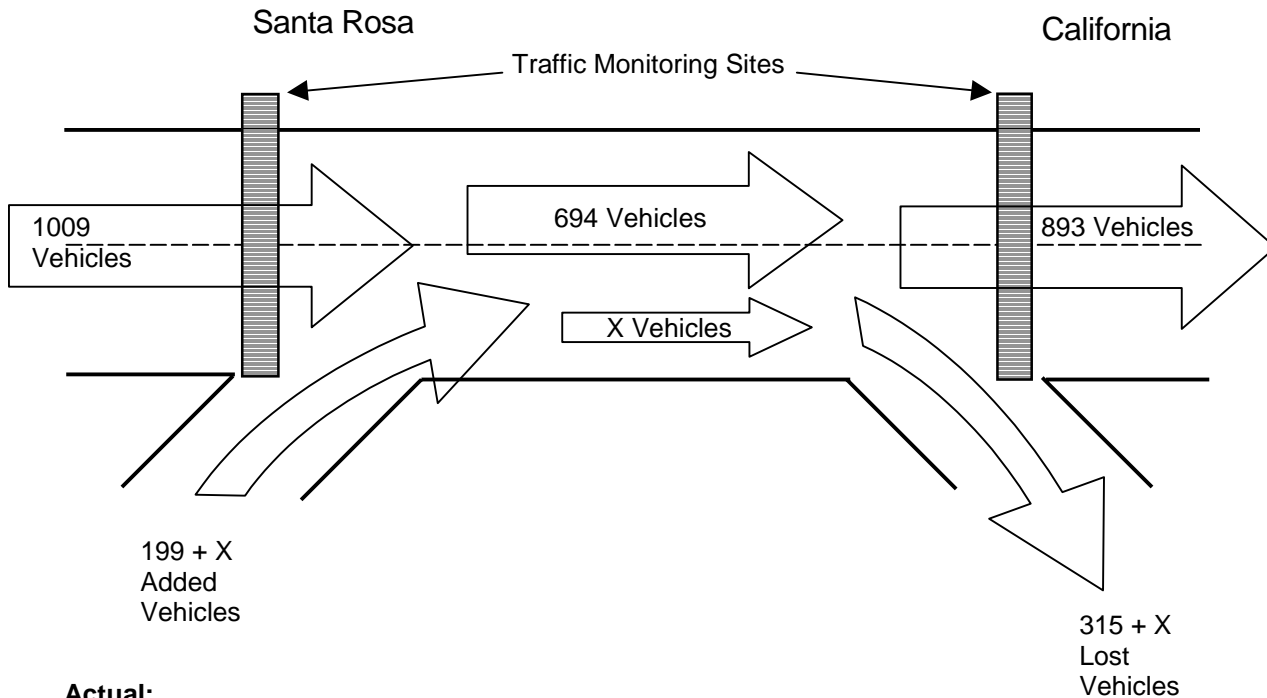

Actual:

57 minute data run
 1009 vehicles at site 1
 893 vehicles at site 2
 694 vehicles from site 1 arrived at site 2 (total possible matches)
 315 vehicles from site 1 did not arrive at site 2
 901,037 possible pairings
 900,343 total possible incorrect matches

V2SAT Results:

743 matches reported: 642 correct + 101 incorrect*
 52 failures to match

Normalized Accuracy:

Percent vehicles correctly matched out of total possible matches: 92.5%
 Percent incorrect matches out of total possible incorrect matches: 0.0112%

* Of the 101 incorrect matches, 87 were pairings consisting of one or both vehicles that appeared at only one site.

Field Test Data 10-5-99 Early Afternoon

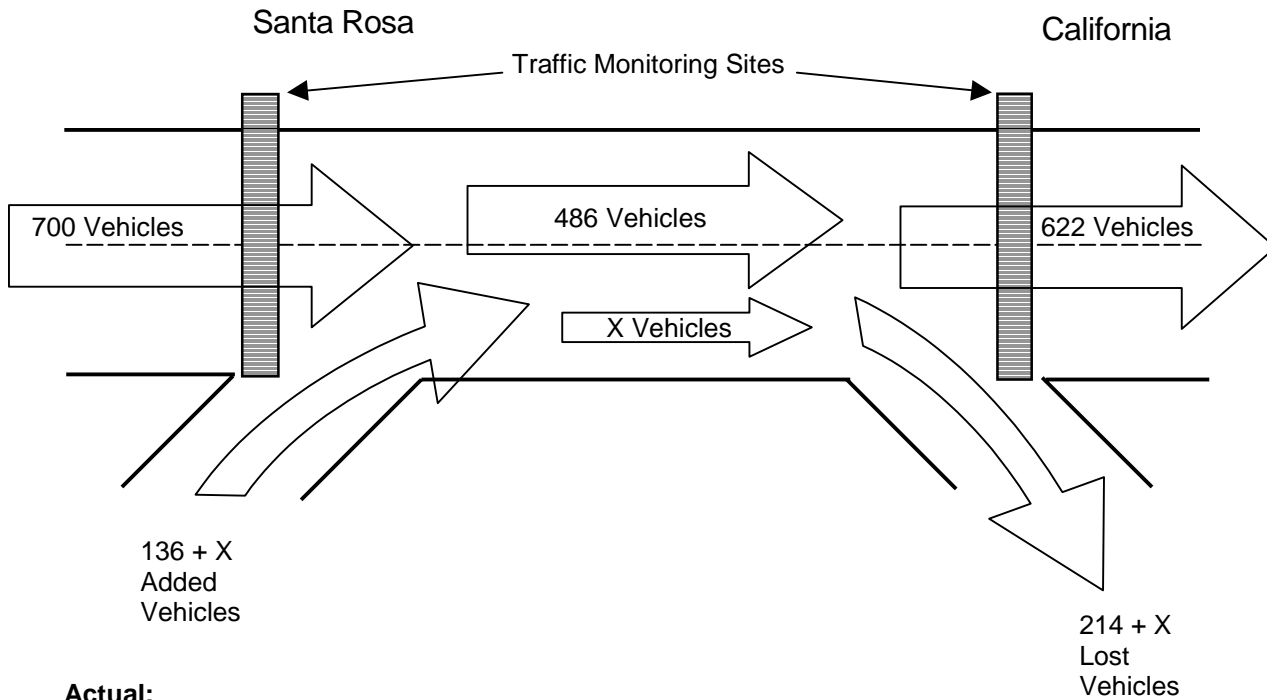

Actual:

38 minute data run
700 vehicles at site 1
622 vehicles at site 2
486 vehicles from site 1 arrived at site 2 (total possible matches)
214 vehicles from site 1 did not arrive at site 2
435,400 possible pairings
434,914 total possible incorrect matches

V2SAT Results:

496 matches reported: 453 correct + 43 incorrect*
66 failures to match

Normalized Accuracy:

Percent vehicles correctly matched out of total possible matches: 93.2%
Percent incorrect matches out of total possible incorrect matches: 0.0152%

* Of the 43 incorrect matches, 38 were pairings consisting of one or both vehicles that appeared at only one site.

Composite Test Results

Overall accuracy results from the three test periods are reported below:

Total individual vehicles observed: 4,243

Average accuracy over all three tests, weighted by number of vehicles detected in each test:

- Self-correlation Accuracy (correctly re-identify vehicles at successive sites): 93.6%
- False-correlation Errors (incorrectly match different vehicles at successive sites): 0.0116%
- Presence detection accuracy (ability of V2SAT to detect and capture images of vehicles, verified by manual counts from video tapes): 97.0%

Observations Related to System Errors

Observed reasons for false matches:

- Vehicle detected at first site does not arrive at second site, but V²SAT finds another vehicle that is very similar (almost all cases).
- Different vehicles have very similar top views.
- Vehicles have little or no chromatic information. Only 32.9% of vehicles observed had any usable chromatic information. White is apparently the most popular color for cars and trucks.

Observed reasons for failures to match:

- Vehicle not detected by V²SAT (3.0% of vehicles are missed).
- Video artifacts at one site change image of vehicle sufficiently to make it appear different at other site.
- Poor vehicle alignment in lane at one site (changing lanes).
- Vehicles have little or no chromatic information (same as above).
- Vehicle changes speed radically between sites.

System Limitations

- Among the non-numeric observations from Phase 2 tests are the following observed limitations of the V²SAT system:
- V²SAT requires adequate, even illumination of targets. This generally limits it to daylight operation, or night operation with artificial illumination.
- Detection area must not contain both very bright and very dark areas – e.g., bright daylight and large dark shadows. This exceeds limited dynamic range of CCD video cameras.. Specific examples are illustrated in the following section.
- Must be able to clearly image at least the first 12 feet of each vehicle.
- Individual video cameras required for each lane in current version of system. This is inconvenient and limits the number of candidate overhead structures (usually overcrossing bridges) which may be used as detector sites.

Problems Related to Limited Dynamic Range of CCD Video Camera

If the camera sensitivity is set high enough to adequately image shadow area, destructive saturation of the sunlit area occurs, resulting in loss of image information. The VSV is inaccurate under such imaging conditions.



Figure 24. Camera sensitivity set high. Result is saturation of sunlit areas.

Similarly, if the camera sensitivity set low enough to adequately image sunlit area, the result is the loss of all information in shadowed area. As with the saturated case, the VSV becomes inaccurate and unreliable.



**Figure 25. Camera sensitivity set low.
Result is loss of intensity information in shadowed area.**

General Conclusions and Future Direction

Building upon results of Phase 1 work, computer vision algorithms were developed to mechanize the automated detection of Video Signature Vectors for every vehicle passing beneath video cameras on a freeway. Field tests were conducted using an experimental version of this system positioned at two successive sites on US 101 in San Luis Obispo.

Under a full range of daylight illumination conditions and 4,243 vehicles observed:

1. The experimental V²SAT system was capable of correctly re-identifying vehicles at successive sites for 93.6% of the vehicles that appeared at both sites.
2. The V²SAT system incorrectly matched different vehicles at successive sites for 0.0116% of the different vehicles that appeared at both sites.
3. As a metric of basic ability to simply acquire VSV's, the V²SAT system demonstrated the ability to detect the presence of vehicles and generate complete vectors for 97.0% of all vehicles passing through the field of view of the detection camera.
4. Chromatic (color) information is of limited value for vehicle correlation. Only 32.9% of vehicles observed had any usable chromatic information. White is apparently the most popular color for cars and trucks.
5. Video artifacts such as harsh shadows at one site change image of vehicle sufficiently to make it appear different at other site. This appears to be a key source of error among vehicles for which vectors were successfully generated.
6. Poor vehicle alignment in lane at one site (changing lanes) also contributes to reduced vector accuracy, since only part of the vehicle may be in the detection zone.
7. V²SAT requires adequate, even illumination of targets. This generally limits it to daylight operation, or night operation with artificial illumination. Conventional CCD color video cameras are subject to the loss of chromatic information under low-light conditions and at very high shutter speeds. The V²SAT method is not usable at night without provision for supplemental illumination of the detection area or the use of specialized high-dynamic-range cameras.
8. Detection area must not contain both very bright and very dark areas – e.g., bright daylight and large dark shadows. This exceeds limited dynamic range of CCD video cameras. Specific examples are illustrated in the following section.
9. For current vector generation algorithms, the camera must be able to clearly image at least the first 12 feet of each vehicle in order to generate a complete vector.
10. The need for individual video cameras above each lane is inconvenient, and limits the number of candidate overhead structures (usually overcrossing bridges) which may be used as detector sites. This is seen as the main practical impediment to deployment of the V²SAT system.
11. On the basis of these observations, we conclude that, subject to limitations associated with detector placement, the V²SAT method has the potential to serve as a reliable means for non-intrusively tracking the progress of individual vehicles along a freeway network under daylight conditions.

References

- Benson, Blair K. ed., "Television Engineering Handbook" McGraw Hill, USA, 1986.
- MacCarley, C.A. and Hockaday, S., "Evaluation of Image Processing Technology for Application on Highway Operations," Final Report to the California Department of Transportation, TR 91-2, June 1991.
- MacCarley, C.A. and Sullivan, E. "Dynamic Extension of Static Traffic Flow Models for Computer Simulation," Proc. IEEE Pittsburgh Simulation and Modeling Conference, Pittsburgh, PA, May 1992.
- MacCarley, C.A. "Evaluation of Closed-Circuit Television Technology for Application in Highway Operations," Final Project Report, Caltrans Contract 51J932, California Polytechnic State University, San Luis Obispo, CA., 1992.
- MacCarley, C.A., Hockaday, S., Need, D. and Taff, S., "Evaluation of Video Image Processing Systems for Traffic Detection," Transportation Research Record No. 1360, National Research Council, Washington D.C., 1992.
- MacCarley, C.A., Need, D. and Neiman, R. "Video Cameras for Roadway Surveillance: Technology Review and Product Evaluation Results," Transportation Research Record No. 1410, National Research Council, Washington D.C., 1993.
- MacCarley, C.A. and Ponce, L. "Video Technologies for Roadway Monitoring and Automated Detection", Society of Automotive Engineers, International Congress and Exhibition, Detroit, MI, 1996.
- Olsen, Robert A., Gustavson, Robert L., Wangler, Richard J., and McConnell, Robert E., "Active-Infrared Overhead Vehicle Sensor, IEEE Transactions on Vehicular Technology, Vol. 43, No. 1. Feb. 1994.
- Palen, Joseph, "The Need for Surveillance in ITS (Part 2)" in Intellimotion, Issue 6.2, Partners for Advanced Transit and Highways (PATH), Univ. of California, Berkeley, 1997.
- Tam, Robert, "PATH's Role in FOTs" in Intellimotion, Issue 5.3, Partners for Advanced Transit and Highways (PATH), Univ. of California, Berkeley, 1996.

Appendix

Note: All appendices, as well as PDF file for this document and V2SAT software package, are included in V2SAT Phase 2 Final Report Compact Disk (CD) Set. Contents of 5-disk set:

1. Main Report (CD 1)

2. V2SAT Phase 2 System Field Test Setup Procedures / Checklist (CD 1)

3. V2SAT program files (CD 1)

V2SAT - Detection modules software

V2SERV - Server software

V2VIEW - Data reduction and analysis software

4. Data and Correlation Results Files from Field Tests of Experimental System (CD 1-5)

Final data reduction in laboratory, data set 1, September 2, 1999 (CD 1)

Final data reduction in laboratory, data set 2, October 5, 1999 (CD 1)

Field tests August 1999 (CD 2)

Field tests August 1999 (CD 3)

Field tests September 1, 1999 Set 1 (CD 4)

Field tests September 1, 1999 Set 2 (CD 5)

Appendix

V2SAT Phase 2 System Field Test Setup Procedures

Preliminary Connections

1. Connect the power strip from each V2SAT unit to the power strip from the UPS.
2. Using the BNC cable contained inside the unit with the wireless modem, physically connect the network cards of all the machines at the site.
3. Attach Cameras to the mounts, assuring the camera to mount connection is rigid and sufficient to keep the cameras from rotating or sliding.
4. Connect the power and signal cables located inside each V2SAT enclosure to the back of each camera. Assure that the power and signal cables are connected to the power bar and VCR respectively.

Camera Mounting

1. Attach the camera mount security cable to the overcrossing railing.
2. Mount the cameras over each freeway lane, aligning them with the direction of each lane, and centered above each lane. Assure that the vehicles will travel horizontally across the field of view from right to left. Depending on the location, attachment is accomplished by either tightening two wing nuts or securing with a yellow strap.

System Power Up

1. Turn on the UPS by pressing and holding both the test and power switches simultaneously.
2. Boot the computers by pressing the power switches located inside the locking cover of each PC.
3. Turn on the modem and VCRs via respective power switches on each.
4. Turn on the ricochet modem and establish a network connection by double-clicking the *Ricochet* dial-up networking icon located on the desktop.

Camera Setup

1. Make sure the VCR is set to channel L-1, the rear video inputs. This is accomplished by pressing the up and down error buttons on the VCR to the left of the LCD display.
2. Run *v2setup.exe* off the desktop by double-clicking it's icon. Use the menu, ok, up and down buttons on the VCR to switch the rear input to S-VHS. This option will be found under the *Functions* submenu. Exit the VCR setup by pressing menu.
3. You should be able to see the image from the video camera in the *v2setup* display. Make sure the vehicles travel perfectly horizontally across the field of view, make any camera adjustments necessary to accomplish correct alignment.
4. Adjust the focus on the camera to infinity, make sure both switches on the rear of each camera are down and that the gain is fully counter-clock-wise and the white balance knob is straight down.
5. Double check that the alignment and position of the camera is correct, the center of the lane should be horizontal and pass down the center of the image. Assure that the camera is pointed as straight up and down as possible without having more then a small sliver of the overcrossing, or its shadow, visible on the left side of the image. If more of the overcrossing or shadow is visible, tilt the camera out until the overcrossing just passes from view.
6. Assure that the focus of the camera is correct. Adjust the focus if the lane lines are not crisp or details in the road surface are blurred and not distinguishable.
7. Draw a box with the mouse in *v2setup* over the lane as large as possible but not including any of the lane lines. Now adjust the F-stop to achieve an average intensity of 110 in the boxed area of the scene. This value will be the second reading in the lower display window of *v2setup.exe*.

Setup Detection Window

1. Close *v2setup.exe* and run *v2sat.exe* which is also located in the bin directory on drive d.
2. Call Loragen by cell phone to request launch of the correlation engine, network communications and vector processing.
3. In the *Site Number* and *Lane Number* windows enter the respective site and lane number. Remember that lane 1 is the fast lane with the number increasing as you progress towards the slow lane.
4. Connect the computer with the wireless modem to the network by selecting *Internet connection* and clicking *connect*. All other computers (non-modem equipped) will connect to the machine with the modem by selecting *local TCP/IP connection*, entering the machine name as *V2SAT#* where # is the machine number (inside the front door of the computer) with the wireless modem, and then clicking on *connect*.

Initialize Parameters for Site

1. Once the machines are connected, click on *Go*. After a brief pause, a tall input window will be displayed. Enter the height of the camera above the road surface (in feet) in the *Height* blank and then click *Submit*. Once you verify that the value you entered is shown correctly, click *Hide*. The V2SAT display should now show live images acquired by the camera.
2. Start the VCRs recording at exactly the same time at both sites to synchronize the start of recording between sites. Use the Motorola communicators to talk to the team at the other site.
3. Using the mouse, draw a box in V2SAT over the lane to be examined. The box should cover the entire lane including the lane lines (but no more than 2 feet of the adjacent lanes at the widest point in the view). Both the upper and lower lane lines should be visible inside the view. The left and right sides of the box should be close to, but not touching, the edge of the overcrossing and the right edge of the display respectively.
4. The sample screen capture below, taken from northbound lane 1 at the Santa Rosa overcrossing, is an example of correct camera positioning and placement of the detection window.
5. Notice the lane lines in relation to the outside of the mouse box. The center on the lane travels perfectly horizontal with the image. The rate at which the lane lines converge towards the right of the image give a good idea how much the camera should be angled out towards incoming traffic. Any more convergence than shown is an indication of excessive camera angle.
6. Check that the boxed area is generally in the center of the whole image. The centerline of the lane should be running along the center of the box and overall image.

