

# UC Irvine

## UC Irvine Previously Published Works

### Title

A method for digitized flow-volume curves and expiratory resistance measurements using standard ventilatory equipment

### Permalink

<https://escholarship.org/uc/item/8nb038wg>

### Journal

Journal of Critical Care, 7(4)

### ISSN

0883-9441

### Authors

Brenner, Matthew  
Kayaleh, Raouf  
Finegan, Robert  
[et al.](#)

### Publication Date

1992-12-01

### DOI

10.1016/0883-9441(92)90019-4

### Copyright Information

This work is made available under the terms of a Creative Commons Attribution License, available at <https://creativecommons.org/licenses/by/4.0/>

Peer reviewed

## ORIGINAL INVESTIGATIONS

# A Method for Digitized Flow-Volume Curves and Expiratory Resistance Measurements Using Standard Ventilatory Equipment

Matthew Brenner, Raouf Kayaleh, Robert Finegan, David Mukai, Eddie Arriss, Emad Mikhail, Frank Dalen, and Archie F. Wilson

Pulmonary resistance may be assessed in ventilated patients by analysis of passive expiratory pressure and flow properties of the respiratory system. Such measurements are generally complex and require specialized equipment. To facilitate expiratory airway mechanics measurements, we have developed a method for automatically recording and analyzing expiratory pressure flow curves in mechanically ventilated patients using standard ventilatory equipment and a personal computer. Simultaneous digital pressure, flow, and volume recordings are obtained with this system during exhalation. These values allow continuous calculation of ventilator circuitry and total system resistance, which could be used for assessing expiratory airway resistance in intubated patients. The accuracy of these methods was tested by comparison to standard analog recorder pressure-flow methods using two lung models as well as by testing in normal volunteers ventilated through a mouthpiece. In all situations (flows, pressures, and volumes) there was excellent correlation between data generated from the automatic digital method and standard analog meth-

**M**EASUREMENTS of flow properties of the lungs have been used extensively for evaluation of pulmonary function in non-intubated patients. Analysis of expiratory flow curves in intubated patients is becoming an increasingly important tool for assessing changes in pulmonary resistance and compliance.<sup>1-8</sup> Obtaining accurate expiratory flow-volume, pressure-volume, and volume-time curves in ventilated patients is technically complex and requires specialized equipment, such as pneumotachographs, pressure transducers, amplifiers, integrators, and recording devices. We have developed a method that simply and automatically constructs accurate digital flow curves using standard ventilatory equipment (Servo Model 900C and SCM 990, Siemens Co, Schwabmeier, IL) and a personal computer.

The instantaneous expiratory resistance of the respiratory system can be derived using time-constant cord methods.<sup>7</sup> With these methods, the rate of lung deflation and respiratory system compliance are used to calculate total

ods (all  $r$  values  $> .9$ , slopes 0.9 to 1.02,  $P < .001$ , flow bias  $-0.02$  L/min, flow precision 0.08 L/min, volume bias 0.008 L, volume precision 0.027 L). Expiratory resistance (using expiratory time-constant cord methods) also correlated well between automatic digital and standard analog analyses ( $r = .9$ , slope 0.98,  $P < .001$ ). We found that expiratory flow limb resistances (airway, tubing, filters, and valves) were substantial (range, 5.5 to 14.0 cm H<sub>2</sub>O/L/s) and are varied throughout the expiratory cycle. Therefore, measurement of expiratory-flow limb resistance is necessary for accurate clinical assessment of pulmonary resistance for any system analyzing expiratory flow mechanics in ventilated patients. We conclude that this simple and convenient method allows automatic and accurate construction of pulmonary expiratory flow properties and may enable measurement of passive expiratory resistance. Rapid and accurate measurements of expiratory lung mechanics may be possible at the bedside of ventilated patients using standard ventilatory equipment with these methods.

Copyright © 1992 by W.B. Saunders Company

expiratory resistance.<sup>5,9-11</sup> Total expiratory resistance comprises airway resistance of the patient (or lung model) as well as resistances of the endotracheal tube and the remaining portions of the expiratory flow limb (including airway tubing, filters, and valves). The difference between total expiratory resistance and expiratory flow limb resistance represents the expiratory resistance of the patient (plus endotracheal tube resistance). Since expiratory resistance of the ventilator circuitry significantly affects out-

---

From the Division of Pulmonary and Critical Care Medicine, The University of California Irvine Medical Center, Orange, CA.

Received October 18, 1991; accepted May 16, 1992.

This article has been published previously in abstract form (*Am Rev Respir Dis* 141:A578, 1990).

Address reprint requests to Matthew Brenner, MD, Department of Medicine, Pulmonary and Critical Care Medicine Division, University of California Irvine Medical Center, 101 City Dr S, Orange, CA 92668.

Copyright © 1992 by W.B. Saunders Company  
0883-9441/92/0704-0002\$05.00/0

flow in intubated patients, accurate measurement of lung resistance and expiratory time constants in intubated patients requires careful determination of the expiratory ventilator limb resistance.<sup>5,9-12</sup> Simultaneous recording of flow, pressure, volume, and time with this system enables continuous determination of total expiratory system resistance, as well as expiratory flow-limb resistance.

We designed a method to measure passive expiratory lung mechanics using standard ventilatory equipment and a personal computer. The expiratory flow limb effects on total respiratory resistance can be assessed to better evaluate expiratory airway resistance with this system. These methods are validated using two mechanical lung models (tanks and bags) and normal volunteers in this study. Flow curves obtained using this automatic digital technique were compared with those obtained by standard analog methods. Passive expiratory resistances measured by the automated digital methods were compared with resistances obtained by standard analog methods. The data indicate very close approximation between the automated digital approach and the standard analog methods. This study also demonstrates that the magnitude of expiratory flow limb resistance is significant and must be measured to accurately estimate airway resistance by expiratory flow methods.

## METHODS

Simultaneous standard analog and automatic digital expiratory flow measurements were obtained in two lung model systems and in normal volunteers.

### *Analog Measurements*

Analog pressure measurements were obtained by placing a pressure transducer probe (Validyne, MP-45, Northridge, CA) in the respiratory tubing adjacent to the mouthpiece on the expiratory side. The transducer output was connected to a carrier demodulator (model MP45, Validyne Co) and the signal sent to an X-Y-Y recorder (model PM8132, Phillips, Japan). The pressure transducer was calibrated with a water manometer prior to all measurements. Standard manufacturer-supplied ventilator tubing connected the expiratory port of the ventilator (Siemens, Servo 900C) to a rolling seal spirometer (CPI, Houston, TX). The spirometer was connected to the X-Y-Y recorder for exhaled volume and time relationships. The spirometer was calibrated with a 3-L syringe (Collins, Braintree, MA) prior to each set of

measurements. Flow-volume and pressure-volume curves were obtained simultaneously during each measurement. Volume-time curves were obtained on separate runs using the same experimental arrangement. Analog flow measurements were obtained from the rolling seal spirometer as the first derivative of the volumetric measurements with time (obtained electronically). The experimental set-up for obtaining expiratory flow, volume, and pressure measurements is illustrated in Fig 1.

### *Digital Measurements*

Digital measurements were obtained by sampling the signals generated from a Servo 900C ventilator and 990 SCM (model SCM 990, Siemens Co) converting module. The Servo ventilator with 990 SCM has flow and pressure transducers on both inspiratory and expiratory circuits (Fig 2). Pressure, flow, volume, and time data recording has been described previously.<sup>13</sup> In brief, digital pressure recordings from the Servo 900C ventilator and the 990 SCM converter were obtained by connecting the serial output of the 990 SCM RS232 port to an IBM-compatible AT-PC computer. Standard communications software (Procomm 2.3, PIL Software Systems, Columbia, MO) directed pressure and flow sampling outputs at 10-millisecond intervals. Following transfer to the computer, digital pressure signals were stored on disk for subsequent analysis.

### *Data Analysis and Display*

A basic program was developed to organize the data and to convert the digital data to flow-volume, pressure-volume, and volume-time curves for graphic display (Appendix). These curves were then analyzed at specific values for comparison with analog tracings. The following values were obtained from each analog and digital flow-volume curve: volume at flow rates of 0.2, 0.4, 0.6, and 0.8 L/s and at 1 second, peak expiratory flow, and the expiratory flow 25% to 75% (the flow rate in the middle two quartiles of the expiratory volume). Additionally, flow rates at 25%, 50%, and 75% of total expiratory volume were determined. Finally, peak pressure was measured from each pressure-volume curve.

### *Lung Models*

Accuracy of measurements made with digital methods was validated using two mechanical lung models: (1) a rigid tank with a volume of 1.5 L and linear compliance of 0.021 L/cm H<sub>2</sub>O and (2) a rubber bag with a volume of approximately 1 L and compliance of 0.042 L/cm H<sub>2</sub>O. The mechanical lung models were connected to the Servo ventilator with standard noncompliant Siemens Ventilator circuitry (250 mL volume, 3 mL/L/cm H<sub>2</sub>O compliance) through a standard 8-mm endotracheal tube and 8-mm connector. A range of tidal volumes and respiratory rates was chosen for each of the lung models (respiratory rate, 6 to 20/min; tidal volume, 0.2 to 1.8 L). Measurements of standard analog curves were compared with concurrently determined digital measurements obtained from the Servo 900C ventilator and 990 SCM.

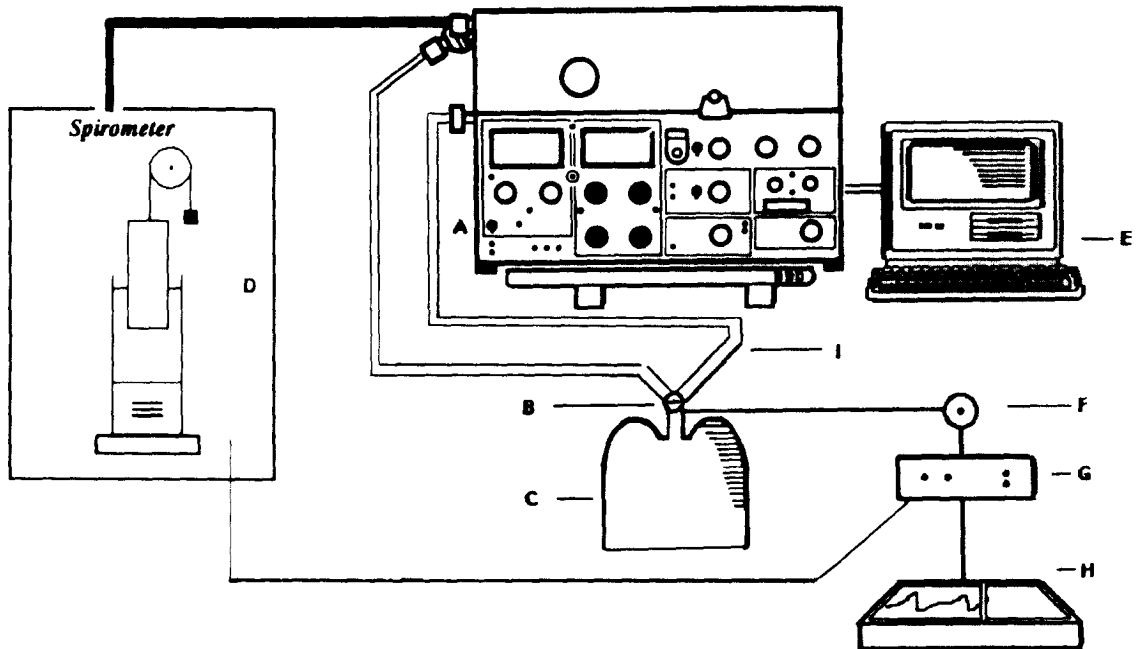

Fig 1. Experimental set-up for measuring concurrent digital and analog flow-volume, pressure-volume, and volume-time curves in intubated patients using standard ventilatory equipment. A, Servo 900 ventilator with 990 SCM analog to digital converter; B, Y connector and analog pressure transducer site; C, lung model with endotracheal tube; D, rolling seal spirometer; E, IBM computer; F, MP-45 pressure transducer; G, carrier demodulator; H, X-Y-Y recorder.

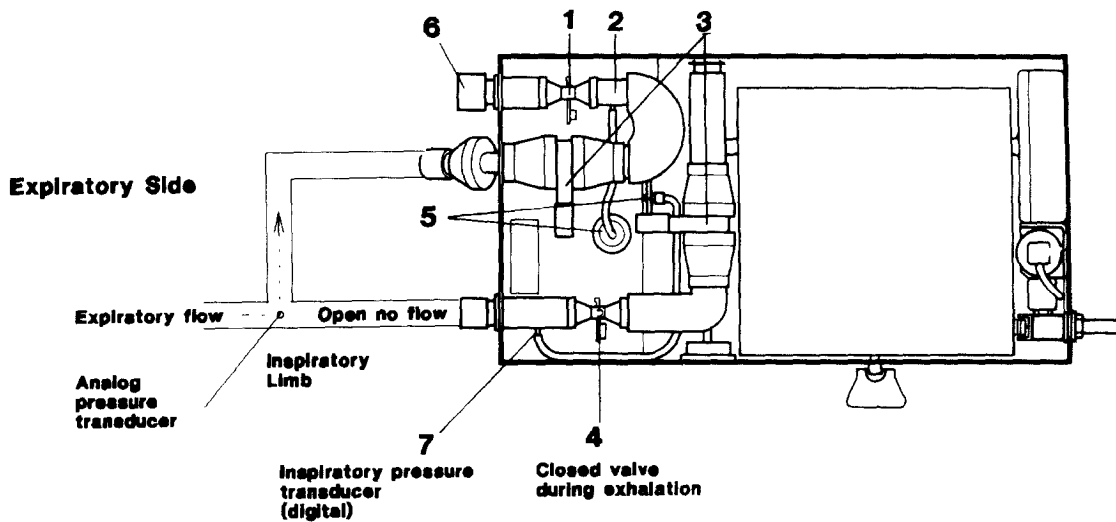

Fig 2. Servo ventilator breathing circuitry and airway control valves. 1, Expiratory scissors valve; 2, expiratory pressure transducer inlet site; 3, inspiratory and expiratory flow transducers; 4, inspiratory scissors valve; 5, inspiratory and expiratory pressure transducers (the inspiratory and expiratory airway flow control scissor valves are shown; note that the pressure and flow transducers are located within the airway circuitry on both the inspiratory and expiratory flow limbs; no flow occurs across the inspiratory pressure transducer during passive exhalation, although the transducer tubing is in communication with the exhalation tubing); 6, expiratory flop valve (illustration modified from Siemens 900C operator's manual); 7, inspiratory digital pressure transducer used in passive expiratory pressure measurements. During exhalation the inspiratory scissors valve (no. 4) is closed proximal to the inspiratory digital pressure transducer (no. 7). There is open communication but no flow between the inspiratory pressure transducer (no. 4) and the analog pressure transducer in the "y" piece near the patient.

A third set of curves was obtained from normal human volunteers breathing through a mouthpiece attached via standard ventilator tubing to the Servo ventilator. The volunteers were sitting comfortably with a nose clip in place. The Servo ventilator was in the volume control mode with a set tidal volume of 10 to 15 mL/kg. The volunteers were allowed to breathe comfortably on the ventilator for several minutes prior to any measurements being obtained. The X-Y-Y recorder and computer were activated simultaneously. Four to six pressure-volume, flow-volume, and volume-time curves were obtained at each setting. Four healthy volunteers were tested. Again, measurements of standard analog recorded curves were compared with concurrently obtained digital measurements.

### Expiratory Flow Resistance Methods

Total instantaneous expiratory system resistance was calculated at any specific flow ( $\dot{V}$ ) or volume ( $V$ ) by determination of instantaneous system time constants ( $\tau$ ). Since  $\tau = R_{\text{sys}} \cdot C_{\text{sys}}$ , the product of total system resistance ( $R_{\text{sys}}$ ) by total system compliance ( $C_{\text{sys}}$ ), instantaneous system time constants were directly measured from the descending limb of the flow-volume curve as follows:  $\tau = V / \dot{V}$  where  $V$  represents the volume of the system above functional residual capacity and  $\dot{V}$  represents flow at any specified volume. This instantaneous "chord" expiratory resistance method is an extension of the classic passive time constant method developed by Comroe et al<sup>11</sup> and McIlroy et al.<sup>5</sup> For systems with nonlinear resistances some changes in the calculation procedure are necessary.<sup>9,10</sup> Instantaneous inspiratory and total expiratory resistances can be calculated at any point on the digital expiratory flow curve by connecting that point to end-expiratory volume (functional residual capacity). The derivation of this equation is as follows: during passive exhalation<sup>5</sup>  $P_{\text{mus}} = 0 = \Delta V / C_{\text{res}} + \Delta \dot{V} \cdot R_{\text{res}}$  and  $\Delta V / \Delta \dot{V} = -R_{\text{res}} C_{\text{res}} = \tau$  (time constant of expiratory pulmonary system). Thus,  $\Delta V / \Delta \dot{V} = \tau$ , where  $\Delta V$  represents change in volume,  $\Delta \dot{V}$  represents change in flow,  $C_{\text{res}}$  represents capacitance respiratory system,  $R_{\text{res}}$  represents resistance of respiratory system, and  $P_{\text{mus}}$  represents pressure of respiratory muscles.

If compliance is known, resistance can be calculated for linear resistance systems in a straightforward manner. For nonlinear resistances, the instantaneous resistance is at any point equivalent to the slope of the line of the flow volume curve to the end-expiration volume, ie,  $\Delta V / \Delta \dot{V} = V / \dot{V}$ . Thus, the slope of this line is the chord of the curve and is equal to  $\tau$ . Measurements of analog total expiratory resistance at 50% of expiratory volume were obtained by drawing the chord from end-expiratory volume to the point at 50% of the total exhaled volume.

The total expiratory system resistance is composed of the lung model, the endotracheal tube, and the resistance of the expiratory flow limb (tubing, valves, filters, and flow transducers).<sup>5</sup> The proximal pressure transducer is located on the inspiratory limb and the distal transducer is located on the expiratory limb distal to the inspiratory scissors value.

During exhalation, no flow occurs across the proximal pressure and flow transducers (Fig 2). Simultaneous expiratory flow and proximal pressure measurements enable calculation of the instantaneous expiratory flow limb resistance. Expiratory flow limb resistance was calculated as  $R_{\text{exp limb}} = P_{\text{proximal}} / \dot{V}_{\text{exp}}$ . Subtraction of the simultaneously determined instantaneous expiratory flow limb resistances from the instantaneous total respiratory system resistances was used to determine lung model resistance over the flow and volume ranges. The instantaneous percentage of total resistance supplied by the expiratory limb was also calculated at specific points in the expiratory cycle. Resistances were measured with and without a dry expiratory bacterial filter (Star exhalation isolation system 454050 and bacterial filter 454051, Infrasonics, San Diego, CA).

### RESULTS

In total, 40 flow-volume, 63 pressure-volume, and 38 volume-time curves were generated for analysis by automatic digital and standard analog methods. Different numbers of curves obtained for flow-volume, pressure-volume, and volume-time analysis are due to differences in the number of curves that could fit on the analog tracing paper during simultaneous recordings. In all three situations (tank, bag, and human volunteers) there was excellent correlation between the standard analog and digital Servo determinations. Graphs comparing digitally obtained data with that of the concurrently obtained standard analog data appear in Fig 3.

#### Flow-Volume Data

Excellent correlation was found between flow-volume curves obtained from Servo ventilator digital methods compared with standard analog methods. A correlation coefficient of 0.98 with a slope of 1.07 for digital versus analog flow measurements over all volume ranges (0.1 to 1.0 L) was obtained ( $P < .001$ ,  $n = 120$ ,  $r = .98$ , intercept = 0.027 L) in 120 measurements on 40 curves from tanks, bags, and humans (Fig 3, top left).

We also found excellent correlation between volumes determined at specific flow rates (0.2 to 1.8 L/s) by both measurement methods ( $r = .95$ , slope = 0.97,  $P < .001$ ,  $n = 105$ , intercept = 0.02 L) (Fig 3, top center), as well as between flow rates at predetermined volumes. Digital and analog flows compared well at 25% of the total exhaled volume ( $r = .94$ , slope = 1.0,

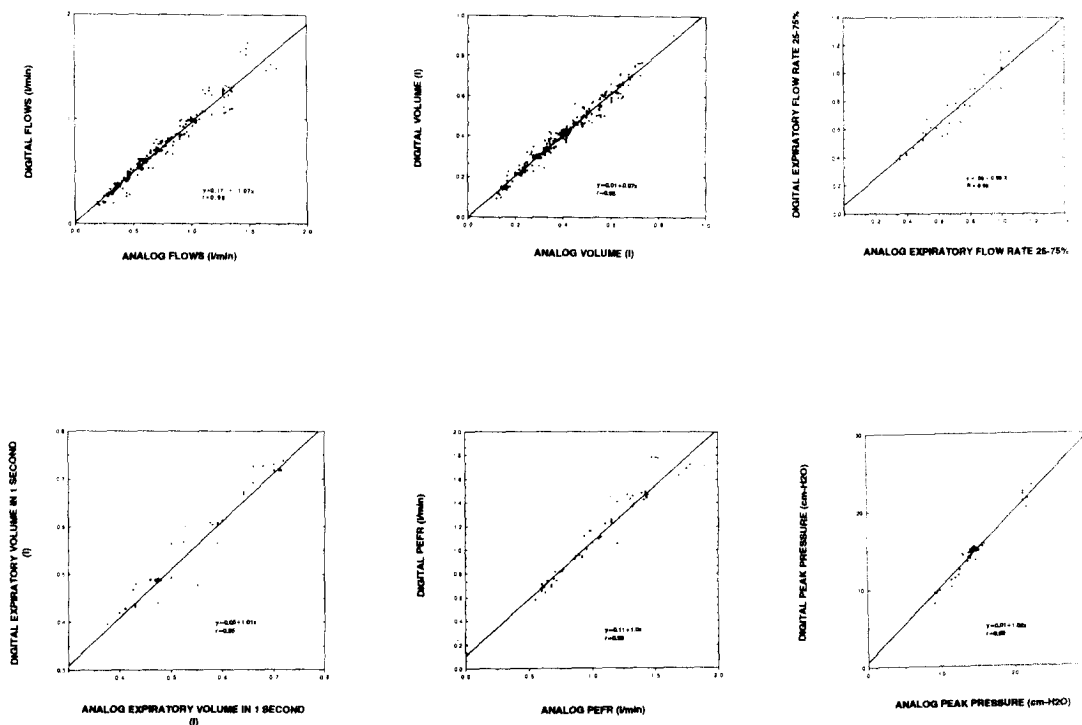

Fig 3. Correlation between flow-volume, pressure-volume, and volume-time measurements obtained by Servo ventilator methods (vertical axis) and standard analog methods (horizontal axis) using the mechanical lung model. The least-squares linear regression line is shown. (Top left) Digital versus analog flows (slope = 1.07,  $r = .98$ ), (top center) digital versus analog volume (slope = 0.97,  $r = .95$ ), (top right) digital versus analog expiratory flow rate 25% to 75% (slope = 0.96,  $r = .96$ ), (bottom left) analog expiratory volume in 1 second (slope = 1.01,  $r = .95$ ), (bottom center) digital versus analog peak expiratory flow rate (slope = 1.0,  $r = .98$ ), (bottom right) digital versus analog peak pressures (slope = 1.02,  $r = .99$ ).

$P < .001$ ,  $n = 40$ ), at 50% of exhaled volume ( $r = .90$ , slope = 0.90,  $P < .001$ ,  $n = 40$ ), and at 75% of the exhaled volume ( $r = .91$ , slope = 0.90,  $P < .001$ ,  $n = 40$ ).

*Pressure-Volume Curve Analysis*

Peak pressures correlated very well between the digital and analog methods ( $r = .997$ , slope = 1.02,  $P < .001$ ,  $n = 63$ , intercept = 0.01 cm H<sub>2</sub>O) (Fig 3, bottom right).

*Volume-Time Curve Analysis*

Again, excellent agreement was obtained between volume-time data obtained from the digital methods versus the analog system. Digital and analog expiratory volume in 1-second interrelations were  $r = .95$ , slope = 1.00,  $P < .001$ ,  $n = 38$ , intercept = 0.05 L/s (Fig 3, bottom left). Peak expiratory flow interrelations for digital and analog methods were  $r = .98$ ,

slope = 1.00,  $P < .001$ , intercept = 0.11 L/s (Fig 3, bottom center). Digital and analog expiratory flow rate 25% to 75% interrelations were also very strong:  $r = .96$ , slope = 0.96,  $P < .001$ ,  $n = 38$ , intercept = 0.06) (Fig 3, top right).

*Variability*

At a given flow rate and vital capacity, passive expiratory resistance measurements varied an average of less than 2% in the lung models (average variance, 0.09 cm H<sub>2</sub>O/L/s for the bag model and 0.08 cm H<sub>2</sub>O/L/s for the tank model). The flow rate bias of the digital methods was (-)0.02 L/min and precision (standard deviation of the difference) was 0.08 L/min in comparison to the analog readings. The volume bias was 0.08 L with a precision of 0.027 L in our analysis. The dry bacterial filter provided an average of  $2.19 \pm 0.5$  cm H<sub>2</sub>O/L/s resistance in the tank system and  $2.01 \pm 0.5$  cm H<sub>2</sub>O/L/s resistance in the bag system.

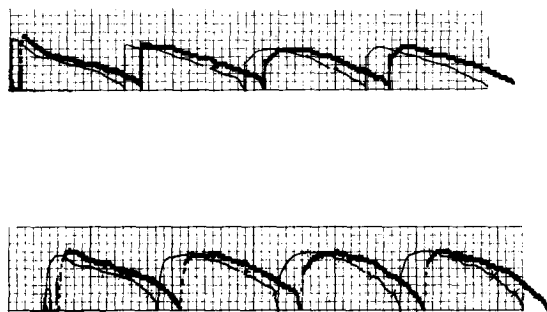

Fig 4. Pressure-volume curves (upper graph) and flow volume-time curves (lower graph) obtained by standard analog pressure and X-Y recorder (left graph) methods compared with pressures obtained with the Servo ventilator digital output method. In the upper curve, pressure is plotted on the Y axis (one small box = 2 cm H<sub>2</sub>O) and volume is plotted on the X axis (one small box = 0.05 L). Digital flows have been offset to the right for visualization purposes. In the lower curve, volume in liters is shown on the vertical axis (one small box = 0.1 L) and time in seconds is shown on the horizontal axis (two small boxes = 1 second). This is a representative tracing from a normal subject breathing on the ventilator. Tracings obtained from the Servo ventilator method (offset 0.15 second to the right for visualization) are virtually identical to standard analog methods.

In Fig 4, digitally obtained curves have been superimposed over the standard analog tracings to allow visual comparison.

#### Resistance Measurements

Total expiratory system resistances at 50% exhaled volume were obtained for the bag and tank lung models by the descending limb flow-volume curve analysis. The total expiratory system resistances at 50% exhaled volume agreed very well between digital and analog methods ( $r = .9$ , slope 0.98,  $P < .001$ ).

#### Variation in Expiratory Resistance With Expiratory Volume

Changes in total expiratory resistance and expiratory flow limb resistance during the expiratory cycle were examined.

1. Tank model: using the noncompliant tank model, expiratory flow limb resistance averaged  $8.45 \pm 2.04$  cm H<sub>2</sub>O/L/s. Expiratory flow limb resistance decreased from an average of  $10.00 \pm 1.94$  cm H<sub>2</sub>O/L/s at 25% of exhaled capacity, to  $8.53 \pm 1.48$  cm H<sub>2</sub>O/L/s at 50% of exhaled volume, to

$6.83 \pm 1.26$  cm H<sub>2</sub>O/L/s at 75% of exhaled volume ( $P < .01$ ). Total expiratory system resistance averaged  $15.56 \pm 4.16$  cm H<sub>2</sub>O/L/s. Total expiratory system resistance decreased from  $18.11 \pm 4.23$  cm H<sub>2</sub>O/L/s at 25% of exhaled capacity, to  $15.82 \pm 3.42$  cm H<sub>2</sub>O/L/s at 50% exhaled volume, to  $12.74 \pm 2.85$  cm H<sub>2</sub>O/L/s at 75% of exhaled volume ( $P < .01$ ).

2. Bag model: a similar resistance pattern was seen in the more compliant bag model. Expiratory flow limb resistance averaged  $8.25 \pm 1.66$  cm H<sub>2</sub>O/L/s. Expiratory flow limb resistance decreased from  $9.18 \pm 1.93$  cm H<sub>2</sub>O/L/s at 25% of total volume, to  $7.79 \pm 1.53$  cm H<sub>2</sub>O/L/s and  $7.77 \pm 1.00$  cm H<sub>2</sub>O/L/s at 50% and 75% of exhaled total volumes, respectively. Total expiratory resistance averaged  $13.27 \pm 2.28$  cm H<sub>2</sub>O/L/s and did not vary significantly through the respiratory cycle. The percentage of the total respiratory resistance provided by the expiratory flow limb in the bag model decreased from  $72.3\% \pm 5.96\%$  at 50% of exhaled volume to  $54.48\% \pm 4.36\%$  at 75% of exhaled volume.

#### DISCUSSION

Expiratory flow measurements have been used in the analysis of pulmonary function for many years. Recent attention has focused on the potential value of expiratory flow measurements in assessing airway resistance and pulmonary function in mechanically ventilated patients.<sup>1-8</sup> Previously, methods for measuring flow curves in intubated patients have required specialized equipment. We describe a method for obtaining digital pressure-volume, flow-volume, and volume-time curves in intubated patients using standard ventilatory equipment and a personal computer. The methodology used in this study has the added advantage of allowing continuous expiratory airway circuitry resistance determination throughout the expiratory cycle by simultaneously measuring pressure and flow of the expiratory flow limb.

In this study we compared the results of passive expiratory flow-volume curves obtained

by standard analog methods with those obtained from the digital ventilator method in two lung models and in volunteers breathing on a ventilator. The results of this study demonstrate that accurate expiratory flow-volume, pressure-volume, and volume-time curves can be readily obtained using this method. In both lung models and human subjects, all digitally determined curves from the ventilator are virtually identical to those obtained by standard analog methods. The digital curves have the advantages of instantaneous automatic analysis of results and the potential for trending capabilities.

Airway resistance measurements are valuable for assessing pulmonary disease processes and response to treatment in intubated patients. Methods for measuring inspiration resistance are widely used in ventilated patients. These methods often fail to account for the inertance of inspiratory circuitry, in particular the component related to the endotracheal tube.<sup>14</sup> Expiratory resistance measurements, on the other hand, are performed on the descending limb of the flow-volume curve, ie, during flow deceleration. Expiratory deceleration rates are much slower than inspiratory acceleration rates in ventilated patients. As a result, expiratory resistance measurements are not substantially affected by system inertance. Furthermore, in subjects with outflow abnormalities such as obstructive airway disease, expiratory resistance often substantially exceeds inspiratory resistance and may reflect more relevant clinical pathophysiology (small airway disease or large airway collapse).<sup>15</sup> Thus, passive expiration flow-volume loops may be useful in determining total expiratory resistance<sup>5,6,9,11,12</sup> in ventilated patients.

Determination of expiratory flow limb resistance is crucial in determining expiration resistance in patients since the expiratory flow limb has a resistance that is substantial and varies with flow. These findings are not surprising in light of the presence in the expiratory limb of a bacterial filter, scissor, and flap valves (Fig 2). Additionally, the resistance of the bacterial filter may change dramatically with increasing humidity and deposition of secretions.<sup>16</sup> Commercial ventilators containing microprocessors that display and analyze expiratory flow mechan-

ics recently have become available. This study demonstrates that the expiratory flow limb resistance contributes significantly to the passive expiratory mechanics and must be taken into account in assessing expiratory airway resistance by such methods.

There are a number of limitations for measurement of expiratory system resistance by time constant methods in critically ill patients with respiratory failure. Exhalation must be passive, respiratory compliance must be determined at the volumes at which resistance measurements are performed, and ventilator breaths must end at functional residual capacity (or at known volumes above functional residual capacity).<sup>4,5,17</sup> However, when the instantaneous cord method of expiratory resistance is used, respiratory compliance does not need to be constant or linear<sup>5,18</sup> as long as the specific compliance is known at the volumes being analyzed.

This study demonstrates that accurate expiratory lung mechanics (pressure-volume, flow-volume, and volume-time curves) can be obtained using standard ventilatory equipment and a personal computer. When passive respiratory compliances are determined, these methods may allow expiratory flow curves to be readily obtainable at the bedside in critically ill patients and have the potential for determining instantaneous passive expiratory resistances in intubated patients.

In the future, passive expiratory resistance measurements may be useful for the evaluation of respiratory physiologic derangements, diagnostic evaluation, following progression of respiratory diseases, and assessing response to therapy (bronchodilators, diuretics, etc). Careful clinical studies will be needed to determine the value of resistance and expiratory mechanics measurements in specific clinical settings. This study also illustrates the need for caution in interpretation of expiratory flow mechanics using commercially available ventilator systems that do not accurately account for variable expiratory flow limb resistances. Further studies will be needed in critically ill, ventilated patients to assess the accuracy of these methods under the broad range of clinical conditions encountered in intensive care unit patients.



## APPENDIX

*Transducer Specifics*

The Servo 900C ventilator inspiratory pressure transducers have a pressure range ( $-$ )20 cm H<sub>2</sub>O to (+)120 cm H<sub>2</sub>O with an accuracy of  $\pm 5\%$  (manufacturer's specifications). The analog sample processing range is ( $-$ )10 V to (+)9.99 V with 4.883 mV/bit resolution and an accuracy of 0.2% of readings. Flow transducers have an analog sample processing range of 0.0 to 10.0 V with  $\pm 10$  mV (or 0.2%) accuracy. The transducers were calibrated prior to use according to the manufacturer's specifications.

Digital 900 SCM signals are optocoupled connections to the RS232 output port.

*Data Analysis*

The data analysis for generation of pressure, flow, and volume curves uses a method analogous to those previously described for determination of P0.1.<sup>13</sup> The first step is the conversion of continuous string data generated by the Servo 990 SCM into discreet data points. The second step is analysis of the data graphically, construction of curves, and analysis of selected curve data.

The steps are accomplished in the following manner:

*Program 1: conversion of string data to discreet time point data.* Conversion of the string to discreet columns of individual data is easily accomplished since the Servo 990 SCM precedes each data point with a letter (I, E, or P) designating inspiratory, expiratory, or pause cycles. We have chosen to read columnar data rather than string data to avoid any misreading if errors occur in any data signal transmission points.

Data files from the Servo 990 SCM are named 1, 2, 3, etc. A batch file performs the following functions:

1. Opens Word Perfect (Word Perfect 5.0; Word Perfect Co, Orem, UT).
2. Opens the first file.
3. Calls up a macro that converts all inspiratory, expiratory, and pause markers to carriage returns.
4. Saves the file in ASCII format.
5. Opens the second file and repeats the preceding sequence until all files have been converted.

*Program 2: flow-volume curve construction and analysis.*

The data processing program was written in Quick Basic 4.5 (Microsoft Co, Redmond, WA). The program performs the following functions:

1. Data is read into the program.
2. Four digit codes are converted to pressures and flows using conversion factors for each channel supplied by the manufacturer (Siemens). Conversion information is as follows:
 

channel 00	airway flow	gain 1.0	offset 2.0	scale 9.7656E-4
channel 02	airway press	gain 1.0	offset 200.0	scale 9.7656E-2
channel 01	insp vol	gain 1.0	offset 2000.0	scale 9.7656E-4
channel 03	expl vol	gain 1.0	offset 2000.0	scale 9.7656E-2
3. The program then graphically displays the pressure-volume, flow-volume, and volume-time curves. Volume-time curves are constructed with the constant sampling interval determining the time axis.
4. After construction of the curves, the program automatically reports the following data:
  - a. Flow-volume curves:
    - Flows at 25%, 50%, and 75% of total volume
    - Volumes at 0.2, 0.4, 0.6, and 0.8 L/s flows
  - b. Pressure-volume curves:
    - Peak pressures
    - Compliance

## c. Volume-time curves:

Expiratory volume in 1-second

Total expiratory volume

Expiratory volume 25 to 75

Peak expiratory flow rate

Resistance measurements:

Total expiratory system resistances at 25%, 50%, and 75% of exhaled volume

Expiratory flow limb resistances at 25%, 50%, and 75% of exhaled volume

Copies of this program will be made available to anyone who is interested. The program runs on IBM-compatible computers with EGA, VGA, or CGA graphics.

## ACKNOWLEDGMENT

The authors thank Michael O'Connor for his assistance in all aspects of this project. They also thank Hedda Schnur for her help in typing and proofreading this manuscript.

## REFERENCES

1. Zin WA, Marlot D, Bonora M, et al: Active and passive respiratory mechanics and control of breathing in kittens. *J Appl Physiol* 55:183-190, 1983
2. Thomson A, Silverman M: Single-breath measurement of lung mechanics in very low birth weight infants. *Crit Care Med* 13:4-8, 1985
3. Prendiville A, Thomson A, Silverman M: Effect of tracheobronchial suction on respiratory resistance in intubated preterm babies. *Arch Dis Child* 61:1178-1183, 1986
4. Lesouef PN, England SJ, Bryan AC: Passive respiratory mechanics in newborns and children. *Am Rev Respir Dis* 129:552-556, 1984
5. McLroy MB, Tierney DF, Nadel JA: A new method for measurement of compliance and resistance of lungs and thorax. *J Appl Physiol* 18:424-427, 1963
6. LeSouef PN, England SJ, Bryan AC: Total resistance of the respiratory system in preterm infants with and without an endotracheal tube. *J Pediatr* 104:108-111, 1984
7. Kayaleh R, Ahdout JJ, Wilson AF: Effect of a variable resistance model upon time constant determination. *Eur Respir J* (in press)
8. Gottfried SB, Rossi A, Higgs BD, et al: Noninvasive determination of respiratory system mechanics during mechanical ventilation for acute respiratory failure. *Am Rev Respir Dis* 131:414-420, 1985
9. Harf A, Zidulka A, Chang HK: Nitrogen washout during tidal breathing with superimposed high-frequency chest wall oscillation. *Am Rev Respir Dis* 132:350-353, 1985
10. Isabey D, Harf A, Chang HK: Alveolar ventilation during high-frequency oscillation: Core dead space concept. *J Appl Physiol* 56:700-707, 1984
11. Comroe JH, Nisell OI, Nims RG: A simple method for concurrent measurement of compliance and resistance to breathing in anesthetized animals and man. *J Appl Physiol* 7:225-228, 1954
12. Brody AW: Mechanical compliance and resistance of the lung-thorax from the flow recorded during passive expiration. *Am J Physiol* 178:189-196, 1954
13. Brenner M, Mukai DS, Russell JE, et al: A new method for measurement of airway occlusion pressure. *Chest* 98:421-427, 1990
14. Sullivan RA, Paliotta J, Saklad M: Endotracheal tubes as a factor in measurements of respiratory mechanics. *J Appl Physiol* 41:590-592, 1976
15. Ingram RH, Schidler DP: Effect of pursed lip expiration on the pulmonary pressure-flow relationship. *Am Rev Respir Dis* 96:381-388, 1967
16. Loeser EA: Water induced resistance in disposable respiratory-circuit bacterial filters. *Anesth Analg* 57:269-271, 1978
17. Zin WA, Pengelly LD, Milic-Emili J: Single breath method for measurement of respiratory mechanics in anesthetized animals. *J Appl Physiol* 52:1266-1271, 1982
18. Pierce JA: Studies of free collapse in the intact human lung. *J Lab Clin Med* 54:96-106, 1959