

UC Berkeley

UC Berkeley Previously Published Works

Title

Patent and Place: Intellectual Property and Site-Specificity

Permalink

<https://escholarship.org/uc/item/8n67r12b>

Author

Hindle, Richard L

Publication Date

2016-03-21

Peer reviewed

Patent and Place: Intellectual Property and Site-Specificity

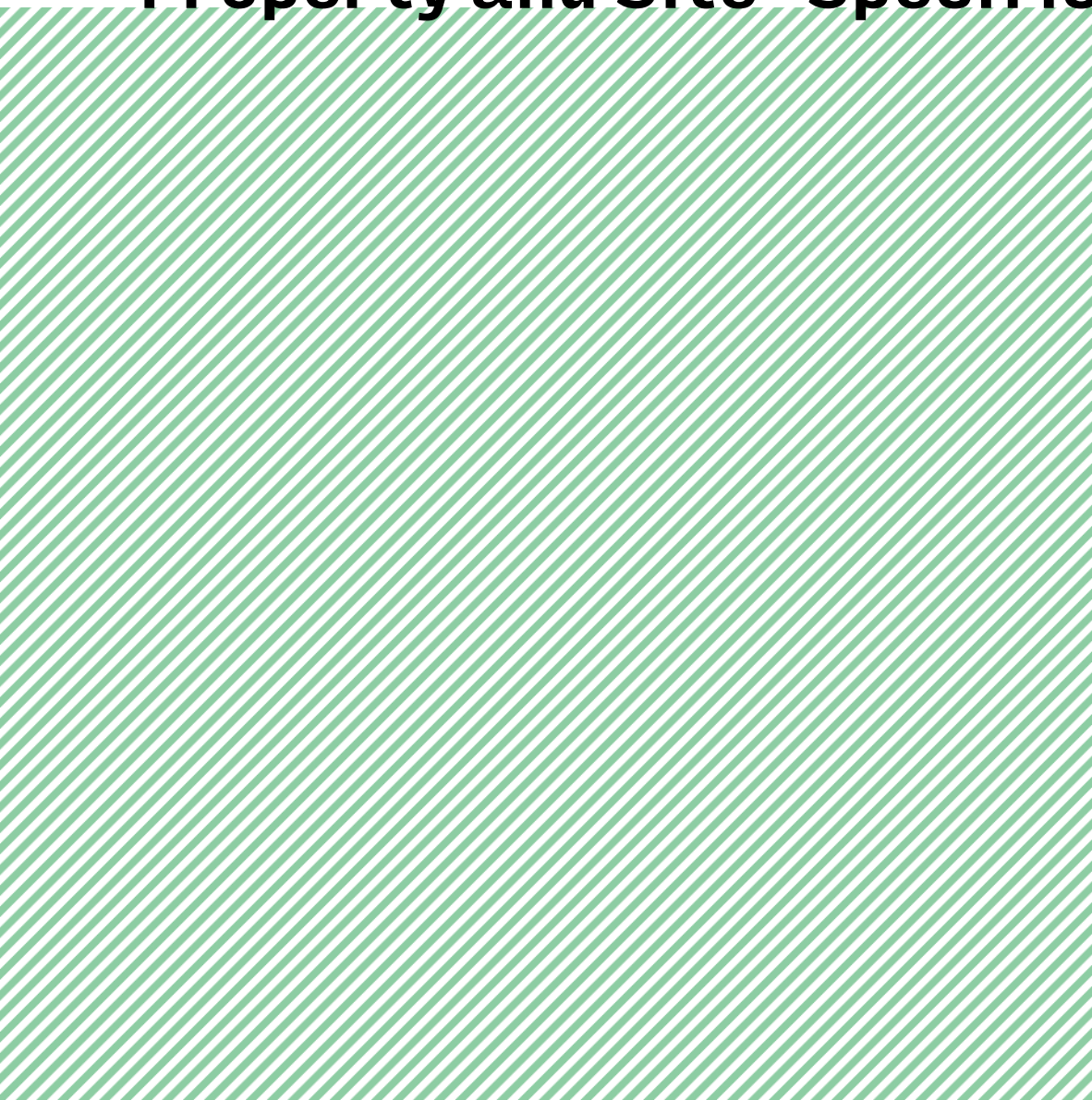

Introduction

Among the more than 9 million U.S. patents granted since the Patent Act of 1790, a representational anomaly exists in which intellectual property and place converge in an evocative yet confounding hybrid at the interstices of technology and environment. For good reasons, known geographical locations are rarely represented in patent documents. The specificity of place precludes the widest interpretation of patent claims and is, therefore, generally omitted from texts and images that aim to protect the broadest interpretation of intellectual property. Besides, direct correlation between the configuration and function of a novel invention and a specific location, landscape, or environmental condition is atypical—obviously. Yet, the schism between patent and place is not absolute, and a unique subset of patents granted by the U.S. Patent and Trademark Office (USPTO) includes texts and images that suggest site specificity within intellectual property claims.

Patent, Representation, and Environment

Patents have operated as an invisible landscape-of-power in the built environment since the Italian Renaissance, when the world's first patent was issued to the eminent architect Filippo Brunelleschi in 1421 for a "machine or ship" and method of transporting materials for his Duomo of Florence, establishing seminal legal and architectural precedents.¹ Brunelleschi's patent protected his invention of a new machine and method for transporting heavy loads by water, solving one of three major engineering problems associated with his novel dome construction processes.² Although the patent's legalese and the dome's structure operated independently on discrete legal and structural principles, they formed together a highly interdependent and deterministic mechanism governing the form of the built environment. In this manner, the patent—western civilization's oldest legal and institutional mechanism for incentivized innovation—has long mirrored, defined, and shaped the built environment, yet failed to represent it eidetically in a way that is commonly recalled.³

Patents do parallel the built environment and design thinking. In his book *The New Architecture and the Bauhaus* (1935), the modernist architect and theorist Walter Gropius foretold the transformation of architecture and design through industrial process, and, true to form, he and his business partner Konrad Wachsmann secured a U.S. Patent for a "Prefabricated Building System" (US2355192) in 1942, applying Bauhaus principles to contemporary housing problems.⁴ Just a few years earlier, in 1938, Stanley Hart White, a professor of landscape architecture at the University of Illinois, unified new steel structural principles with advances in hydroponic technology to create a vertical garden model called the "Vegetation Bearing Architectonic Structure and System." Correlating modern landscape theory to U.S. Patent claims, White's invention was a truly modern accomplishment in

the context of academic *Beaux Arts*.⁵ This coevolution of patent development and the built environment can also be traced through other complex infrastructural and natural systems, such as rivers, coasts, cities, buildings, and designed landscapes.⁶

A patent is, in essence, a representation of a specific invention. U.S. patents have been accompanied by models, drawings, and textual descriptions since the Patent Act of 1790, which established American patent law and pertinent representational standards.⁷ The Patent Act states that grantees shall deliver to the Secretary of State, Secretary of War, and Attorney General “a specification in writing, containing a description, accompanied with drafts or models, and explanations and models (if the nature of the invention or discovery will admit of a model) of the thing or things, by him or them invented or discovered.” If the invention was found to be new and valuable by the cabinet secretaries and the Attorney General, the patent was granted and signed, bearing ultimately the “teste” of the President himself. In that manner, the government and inventors coevolved the technological substrate of “the arts” towards unforeseen ends. Patent law places no restriction on what may be invented or what might be deemed useful or valuable among the arts, opening up a world of possibilities limited only by the ingenuity of the citizenry and the representational standards of the patent, which today is global, territorial, nanoscale, atmospheric, and even astronomical in reach (figures 1a–b).

Most patents related to landscapes, rivers, cities, regions, coastlines, and other complex environmental systems are intentionally site-less, distancing intellectual property claims from any specific locations. Patents of this sort typically use diagrammatic or typological drawings to disclose inventions and protect the widest possible scope of intellectual property claims while maintaining ambiguity as to where the patent might be applied (figures 2a–f). Those drawings cover a range of design thinking and processes—describing workflows, evaluative methods, detailed material configurations, gadgets of one kind or another, and a dizzying array of objects—ultimately representing the environment as a series of typological conditions, tectonic assemblages, data sets, and operations often contingent on specific spatial or physical conditions yet, in essence, without specific sites.

The siteless quality of environmental patent documents does not diminish their potential impact on large-scale complex systems. Consider, for example, the design and construction of Eads’ Jetties at the South Pass of the Mississippi River, near Fort Jackson, a patented system realized between 1875 and 1879 and credited with saving the Port of New Orleans by sustaining commercial activities along the Mississippi (figures 3a–c). James Buchanan Eads and his business partner James Andrews prototyped and tested their jetty system at full scale for four years before receiving their fee for the maintenance of a navigable channel at the mouth of the Mississippi,

radically altering the fluvial geomorphology and ecology at the Head of Passes.⁸ The patent granted to Eads and Andrews was designed to suit the unique conditions at the Heads of Passes, yet the document itself makes no mention of this specific location, referencing only environmental conditions common to deltaic landscapes and a method of construction. We know of the patent's use through Eads' petitions to Congress and detailed histories of the jetties, but the patent itself makes no reference to a known geographical location. Eads' patent may be siteless, but its imprint on a specific landscape is bound to the fabric of culture and remains legible today in the morphology of the Mississippi River.

Site Specific Intellectual Property

The anomaly of site-specificity in patents weaves a distinct narrative through geographies of the American landscape dating back to the earliest days of the Patent Office. In this nascent area of environmental innovation studies, I propose Thomas Paine as the first person to submit site-specific works to the patent office, though we may never know for sure about that precedence as most of the earliest American patents were destroyed in a fire in 1836. Paine never built a steel bridge in America, contrary to what was suggested in correspondence with Thomas Jefferson. He did, however, propose bridges in New York, New Jersey, and Pennsylvania a short time after his book *Common Sense* (1776) helped catalyze the American Revolution. Models of Paine's designs for bridges spanning the Schuylkill and Delaware Rivers were exhibited in France and England prior to being sent to the U.S. Patent Office for dissemination and safekeeping, establishing the earliest known precedent for site-specific works curated by the patent office.⁹

Although the models mentioned in Paine's writings were probably destroyed in one of several conflagrations of the Patent Office, we can reflect on the confounding intersection of intellectual property and place, or real property, and trace a lineage to the environmental challenges of today. Paine's submission of bridge models to the U.S. Patent Office was not an isolated instance of site-specificity within the annals of patent history. In fact, many site-specific works have been premised on intellectual property of one sort or another. These proposals range in scale and scope from design patents that protect the form and appearance of specific buildings, such as architect Wallace Harrison's patent for models of the Trylon and Perisphere (New York World's Fair, 1939–1940) and Apple Inc.'s patent for its store on Fifth Avenue in New York City (figures 4a–c), to utility patents for systems that aim to reconfigure the function and performance of cities, regions, and ecosystems.

Speaking generally, the siteless quality of patents has obscured an intimate relationship between known places and specific technologies. One may easily miss the relationship between patent and place when surveying millions of

documents, which at first glance appear as a treasure trove of things—gadgets, machines, and objects—but not of the environment as a whole, a place, or any known geography. Cartographic forms of representation within patent documents quickly reorient the mind to the potential intersections of intellectual property and environment through the familiar imagery of maps (figures 5a–e). Although patent cartographies usually lack the scale and graticule of conventional mapping, known locations are sometimes clearly demarcated with labels and identifiable boundaries. Not only can those places be recalled, known, or visited in the real world; they are also sites of technological innovation. As representations, the maps range in specificity from systems diagrams that situate an invention within a known location to detailed bathymetries that show the resultant geomorphology of a specific intervention. Examples include proposals for the removal of ice from New York Harbor and the East River, a passive dredge system for Galveston Bay, a hydroelectric plant for Niagara Falls that preserves scenery and produces power, and even current infrastructure/ecology hybrids designed to reinforce and cultivate mangrove ecosystems in Florida and around the world.¹⁰

What is the relationship between patent cartographies and known geographical locations? Site specificity within patents raises important questions about the extents and jurisdiction of patent law, in addition to challenging commonly accepted models for innovation in complex environmental systems. Take, for example, the life work of Lewis M. Haupt (1844–1937), a professor of civil engineering at the University of Pennsylvania and, before that, a patent examiner at the USPTO.¹¹ Haupt’s theories on the “Physical Phenomena of Harbor Entrances” earned him a Magellanic Premium award from the American Philosophical Society in 1887, and, on the same day that he accepted that award, he was granted a U.S. Patent for a “Dike or Breakwater,” which linked his design theories to known environmental conditions and specific locations.¹² Following in the footsteps of Eads and others advancing American infrastructure through public/private partnerships, the “Reaction Breakwater,” as Haupt’s invention was popularly known, was to be prototyped at Aransas Pass, Texas, by the Reaction Breakwater Company using the specification of his patent (figures 6a–c). After a revision to the contract, however, the Federal Government ultimately awarded the bid for construction to another company, which intended to build the breakwater per Haupt’s specifications. During this process, Haupt’s patent was assigned to the U.S. Government for use at Aransas Pass. In turn, the Secretary of War, responsible for overseeing improvements in rivers and harbors, dismissed Haupt’s research and patent as “purely theoretical,” insisting that all of his discoveries were “unconfirmed by experience, and contain nothing not already well known, and which has a useful application in the improvement of our harbors.”¹³ The War Department’s attempt to discredit Haupt’s invention also inadvertently cast doubts on the American Philosophical Society’s

Magellanic Premium, which Haupt defended tirelessly in lectures to the Society and through publications.¹⁴ Haupt eventually petitioned Congress for payment for partial use of his patented invention, but only after the debacle called into question the role of patent innovation in civic and public works under the jurisdiction of the federal government.

Accusations of patent infringement and the botched construction process resulted in a lawsuit between Haupt and the Secretary of War, in which ruling the jetty was declared property of the U.S. Government and, therefore, not subject to intellectual property infringement. Haupt's difficulties proposing innovations for works under the jurisdiction of the federal government and the Army Corps of Engineers did not dissuade him from further explorations, and he continued to develop patent proposals for places such as the Southwest Pass on the Mississippi River, following in Eads' footsteps of twenty-five years earlier at the South Pass (figure 7).¹⁵ In the later years of Haupt's career, he also consulted on the need for innovation in infrastructure and helped formulate a critique of new patent law that attempted to suppress patent innovation in civic works.¹⁶ Interestingly, by 1920, the federal government was involved in fifteen million dollars of patent infringement lawsuits, and several million dollars of suits related to improvements in rivers and harbors.¹⁷

Irrespective of the shifting landscapes of patent law, the ever expanding role of government in large-scale engineering works, or the lack of clear financial incentives for works that preclude commodification, inventors and innovators attempted to reinvent the built environment and natural systems using the legal and institutional mechanisms of the patent. Today, this record provides an inductive view of environmental design thinking and a fruitful repository for future innovation studies. New tools may be needed to link patent innovation to place and the unique conditions, durations, and scales of complex environmental systems. For example, maps and other cartographic forms of representation are not the only indicators of site-specificity in the patent archive. Known geographic locations are also sometimes described in textual claims and descriptions, even though the associated patent diagrams and drawings remain siteless. Mentions of known locations are especially easy to overlook. More than 9 million patents have been granted to date in the United States, and each of those contains many words—even into the tens of thousands—making textual searches for known locations difficult. Nevertheless, even within superficial readings of historical patent texts, we find evocative environmental design proposals, such as a passive levee construction system for California's Central Valley meant to balance source/sink sediment budgets during periods of gold rush, a flood control system along the southern reaches of the Mississippi River prior to the great floods of 1927, a method of constructing navigable channels at the Heads of Passes that potentially stabilizes hectares of deltaic landscape, and others to be discovered.

Redrawing the Places of Intellectual Property

When thinking of patents, one typically pictures some type of *thing*. Historical interrelations among manufacturing, industrialization, and patents has resulted in a distinct “thingliness” (think cotton gins, plows, tie holders, automobiles, toasters, etc.), though business models, construction processes, chemical formulas, cartographic systems, methods of manufacturing, and other “non-things” also have a long history of patent innovation.¹⁸ Things and non-things alike may be granted the protection of a utility patent, given that the nature of their claims is non-obvious, innovative, and discloses the function and configuration of a specific “art.” The hybridizing of geographical studies with patent innovation studies suggests a scale, scope, and orientation for intellectual property claims that verge of the infrastructural, ecological, and environmental. Landscapes are not things, cities are not things, and coastal zones are not things, yet each is subject to the iterative and often deterministic forces of human ingenuity.

In the following texts and images, I investigate site-specific patents that function at landscape and regional scales but with drawings and diagrams that are siteless and scaleless. We know of each patent’s site specificity through the inclusion of geographical terminology and reference to specific places and regions within the patent text, but the scale and impact of the proposed intervention remains open to interpretation. In one drawing per patent, I adapt claims and technical specifications to the geographical location described in the text, synthesizing historical research and maps with the “new” innovation disclosed in the patent. The texts and images presented here are, in their simplest form, ruminations on the intersections of *place* and *intellectual property*. They provide geographical context to patents that may have radically altered the American landscape, transcending the object-oriented history of patents to suggest a new hybrid at the intersection of technology and environmental geography of innovation.

A Medici Proposal for the Mississippi – US Patent 658,795 (figures 8a–c)

Juan Bautista Medici was born in Piedmont, Italy, in 1843 and died in Buenos Aires, Argentina, in 1903. While residing in Italy, he worked as an engineer on domestic railroad projects and the potable water network of Montevideo, Uruguay. After emigrating to Argentina in 1870, Medici became involved in the detailed survey of Buenos Aires. Later, together with the Argentine engineer Lavalle, he graded 175,000 square kilometers of the province of Buenos Aires. The latter was followed by the construction of an extensive network of channels to drain the area and the addition of two navigable channels. This project was awarded a gold medal at the Esposizione Italo-Americana in Genoa (1892).¹⁹ During his illustrious career in Argentina, Medici was also involved in the layout, planning,

waterworks, and construction of the capital of the province of Buenos Aires, La Plata.²⁰ At 57 years old, and after a lifetime's work in civil and hydrologic engineering, Medici submitted his patent to the USPTO with the intention of reconfiguring the delta of the Mississippi River.²¹ Medici intended for his invention to be a direct technological retort, or innovation, following Eads' Jetties at the South Pass of the Mississippi. Medici claimed:

The system of jetties or artificial islets formed of brush and earth employed, for example, in the delta of the Mississippi [*referring to Eads' Jetties*] has fallen short of desired results, owing to the rigid nature of the resistance thus offered to the tremendous force of wave and current, before which force such rigid bodies must eventually give way. I have therefore sought to overcome the defects of such systems in the manner which I will now proceed to describe.

Medici's patent involves the anchoring of a subsurface "forest" or "orchard" of large, cut trees with variable depths relative to the surface to guide flowing water and capture sediment. The field or matrix of vertical trunks and branched canopy would alter the speed and direction of water by establishing a new bathymetry of tree canopies that define channels, islets, and bars at the river delta. The system invites us to imagine a vast deltaic landscape constructed on principles observed in naturally dynamic deltaic landscapes, yet designed to meet human necessity for navigation. Medici's proposed structure is expansive, potentially extending for miles, and would function at a scale commensurate with the deltas of large rivers. When compared with conventional technologies for engineering of navigable channels, such as jetties and breakwaters, Medici's proposal neglects the singular object and, therefore, precludes object-oriented description, evoking instead various conditions found in nature or other large-scale productive landscapes such as field, forest, orchard, plain, island, field, delta, etc.

Protecting Southern Louisiana's Riparian Lands from Overflow – US Patent 488,422 (figures 9a–b)

Linus Weed Brown (1856–1910) was appointed assistant engineer of the City of New Orleans in 1885 and chief engineer in 1892. In those capacities, he completed detailed topographical surveys of the city, including studies of precipitation and run-off and detailed proposals for a drainage system.²² He later published a booklet summarizing the complex engineering works undertaken while he was a city engineer.²³ Brown's work on the drainage of New Orleans necessitated a comprehensive understanding of the Mississippi River levee system and the topography of the region. In 1892, just as he was appointed chief engineer for New Orleans, he was also granted a patent for a "System of Protecting Riparian Lands from Overflow," which advanced the art of flood management by using outlets or "waste weirs" along the lower Mississippi. Located at precise flood elevations along the river's course,

the weirs would carry floodwater to adjacent lakes, where it would be distributed naturally through the vast deltaic network of bayous and channels draining ultimately into the gulf. Brown suggested that his system be implemented at Lake Brogne and Lake Maurepas, and at as many river bends as necessary to distribute floodwaters effectively. Although the primary purpose of Brown's invention was to protect low-lying lands from overflow, it might also have facilitated sediment recharge in a delta starved by levees. Boosters of the "levees only" policy ultimately discredited alternate proposals, including designed outlets such as Brown's, even though critics knew that a levees only solution to flood control would contribute to the collapse and subsidence of the Mississippi River Delta.²⁴ The weir plan was never implemented during the legal period of Brown's patent. Interestingly, the Bonnet Carre Spillway, which employs a weir system to divert water to Lake Pontchartrain, was constructed after the devastating floods of 1927 submerged thousands of acres of land. That event occurred 39 years after Brown's patent was granted and a decade after expert witnesses argued before Congress in favor of waste weirs similar to those Brown proposed for the Mississippi.²⁵

Source/Sink Levee formation in California Delta – US Patent 235,967 (figures 10a–b)

On December 28, 1880, Newton Sewell (1821–1902), a county assessor and landowner in Yuba, California, was granted U.S. Patent 235,967, which describes a passive hydraulic method for levee formation through the construction of check dams within sediment-laden rivers. The dams would divert accumulated sediment to a series of settling enclosures that in turn would become a levee. Sewell's patent for a "Method of Relieving River-Channels of Sediment and Forming Levees" utilizes the energy of rivers, local topography, and river sediment of the gold rush to build levees in California's Central Valley. The design is topographical in nature, correlating the slopes of rivers, dam sequences, and sediment enclosures to the locations of levees. Sewell's invention was conceived in the later years of hydraulic dredging practices for gold mining in the upper reaches and tributaries to the Sacramento and San Joaquin Delta (aka the California Delta)—a mining process that almost choked the delta and San Francisco Bay with sediment. During this period, an estimated 300 million cubic meters of sediment were moved by rivers and creeks from the Sierra Nevada Mountains into the Central Valley and San Francisco Bay—enough material to cover 380 square miles at a depth of one foot. Sewell's design is noteworthy not only for its engineering of the intrinsic fluvial processes of rivers and for linking levee formation to topographical change in river systems, but also for its mastery of regional source-sink sediment budgets in river systems by utilizing the sediment generated upstream, in the distant reaches of the Sierra Nevada Mountains to build levees downstream in the productive alluvial plains of the valley. Sewell also

suggested that the system might be used to “reclaim,” or raise, low lying areas through the addition of sediment—an interesting and farsighted proposal given the massive subsidence in the delta today resulting from extensive levee construction, agriculture, and oxidation of rich organic soils. The process is quite simple, utilizing a series of low-crested check-dams to raise the level of water and divert sediment-laden water into settling enclosures, allowing for levee formation at an increased height relative to the original elevation of the river. Once the levee has formed and the dam is removed, the river elevation recedes to normal and the levee remains elevated. When envisioned serially along the reaches of a river system, a mosaic of leveed lands can be envisioned, similar to the natural bars and highlands formed intrinsically by migrating rivers. Importantly, the system was developed for implementation along the rivers of central California, between the gold rich lands of the Sierra Nevada and agriculturally productive lands of the California Delta, a statewide sediment management plan disclosed in patent.

Conclusion

Patents have indirectly mirrored and defined the built environment since the Italian Renaissance, when the first true patent was issued to the architect Brunelleschi. As the founders of American Democracy pondered innovation and patents centuries later, they created a system to promote invention, limit monopolies, and expand the public domain of shared intellectual property, while simultaneously building a new nation. The potential for environmental transformation implicit in new technologies was well understood by Jefferson and others, yet the future permutations of technology and environment remained indeterminate and unforeseen. Importantly, the authors of the Constitution (1787) and the subsequent Patent Act of 1790 put few limits on what may be patented,²⁶ which liberated the creative spirit of a citizenry to evolve all sectors of “the arts,” including the lesser-known environmental arts. Many important questions are raised by the curious reciprocity between patents and the built environment, including the potential for innovative new ideas to transform places. The anomaly of site-specificity within patents is only one rhetorical and historical framework through which to explore the environmental arts. Within this narrow sampling, or innovation study, we can trace a lineage from Thomas Paine’s bridges for the Hudson and Schuylkill Rivers, to the unrealized deltaic innovations proposed by Juan Bautista Medici at the Mississippi, to the built works of Lewis M. Haupt. They are linked not only by their integration of known geographical locations with specific technological innovation, but also through the precedent they establish for innovation in the environmental arts—work as relevant and formative today as it has been for centuries.



US 20100251789A1

(19) **United States**

(12) **Patent Application Publication**
Baird

(10) **Pub. No.: US 2010/0251789 A1**

(43) **Pub. Date: Oct. 7, 2010**

(54) **GLOBAL WARMING MITIGATION METHOD**

(52) **U.S. Cl. 71/23; 405/52; 705/500; 290/1 R; 290/55; 136/201; 435/266**

(76) **Inventor: James Russell Baird, Nanaimo (CA)**

Correspondence Address:
James Russell Baird
201 3087 Barons Rd.
Nanaimo, BC V9T 3Y6 (CA)

(57) **ABSTRACT**

(21) **Appl. No.: 12/408,656**

(22) **Filed: Mar. 20, 2009**

Publication Classification

(51) **Int. Cl.**
E02B 13/00 (2006.01)
G06Q 90/00 (2006.01)
H02K 7/18 (2006.01)
F03D 9/00 (2006.01)
H01L 35/00 (2006.01)
B01D 53/62 (2006.01)
C05F 11/00 (2006.01)

The present invention provides a method of sequestering carbon dioxide and water in a desert environment. In a first step heat that would otherwise cause thermal expansion of the ocean and resultant sea level rise is extracted to produce energy. A portion of the energy is used to desalinate seawater. The desalinate water is pumped into a desert environment and vegetation is planted in the irrigated desert portion. The vegetation sequesters carbon dioxide. The seawater extracted for desalination further reduces sea level rise. Irrigation water moderates the day and nighttime temperature fluctuations of hot deserts. Lowering the daytime temperature increases the deserts potential to sequester water. The commercial and arable potential of the desert is augmented by the enrichment of its soil by composted vegetation, its irrigation and the moderation of its diurnal temperature fluctuations.

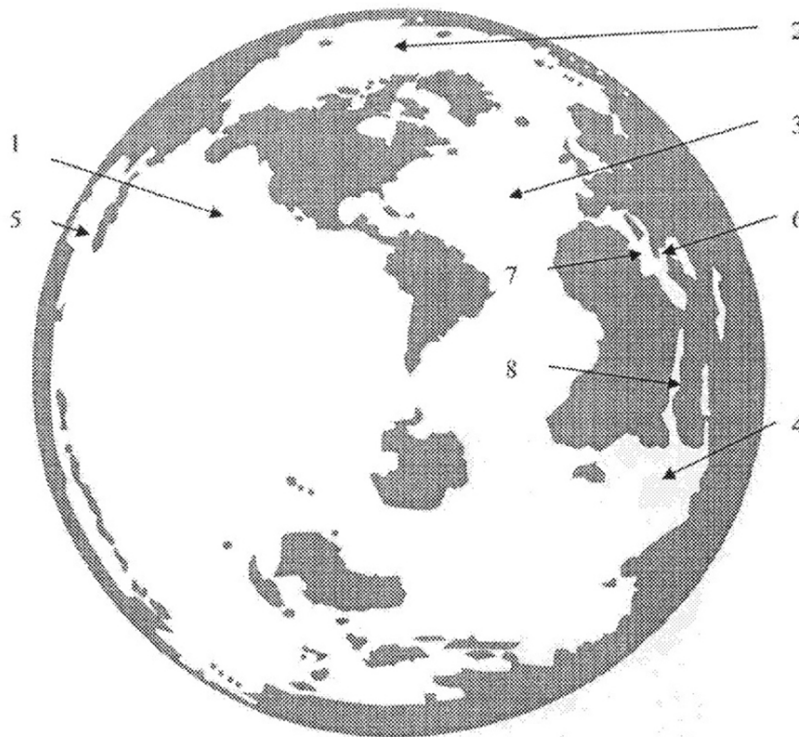

1a: James Russell Baird, "Global Warming Mitigation Method" (U.S. 2010/0251789).

Figures 1a-b: Patents disclose innovation across a range of scales, from nanoscale materials to systems for geoengineering and manipulation of atmospheric systems. Patent documents are currently formatted on 8.5" x 11" sheets, with black and white line drawings and text, making issues of scale particularly salient. The patents shown here operate at the largest known scales for patent innovation.

[54] **METHOD AND APPARATUS FOR TRIGGERING A SUBSTANTIAL CHANGE IN EARTH CHARACTERISTICS AND MEASURING EARTH CHANGES**

3,325,123 6/1967 Null 244/3.21 X
 3,325,123 6/1967 Null 244/1 SA X
 3,521,835 7/1970 Braga-Illa et al. 244/1 SA

[75] Inventor: Neil M. Brice, McLean, Va.

Primary Examiner—Trygve M. Blix
 Assistant Examiner—Barry L. Kelmacher
 Attorney, Agent, or Firm—Jim Zegeer

[73] Assignee: Cornell Research Foundation, Inc., Ithaca, N.Y.

[21] Appl. No.: 164,793

[22] Filed: July 21, 1971

[51] Int. Cl.² B64G 1/10

[52] U.S. Cl. 244/158; 361/230

[58] Field of Search 244/1, 3.21, 3.22, 136, 244/62, 158; 60/202, 204, 203; 317/4, 262; 239/1, 2, 11, 14, 171; 102/3; 315/111; 250/49.5 R, 106 VC; 210/24; 55/103; 176/1, 5; 324/43 R

[57] **ABSTRACT**

There is disclosed method and apparatus for triggering a substantial change in ionospheric characteristics of the earth and measuring certain selected characteristics of the earth. Substantial energetic particle precipitation is triggered through injection of low energy ionized gas, such as hydrogen, in the region of large fluxes of energetic particles in or near the magnetic equator. The loss process is known to occur naturally but a triggered change is achieved through injection of larger amounts of low-energy ionized gas than are naturally present, preferably in the cusp region, which usually extends inside the synchronous orbit for several hours about local midnight.

[56] **References Cited**

U.S. PATENT DOCUMENTS

3,095,167 6/1963 Dudley 244/62
 3,097,480 7/1963 Sohn 60/202
 3,210,926 10/1965 Forbes et al. 60/202

4 Claims, 1 Drawing Figure

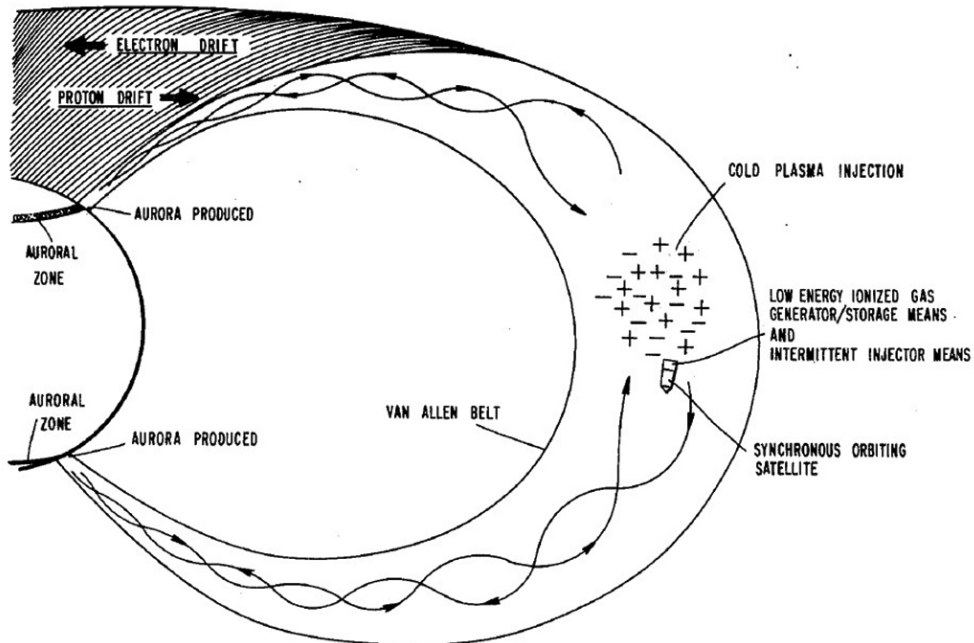

1b: Neil M. Brice, Cornell Research Foundation, "Method and Apparatus for Triggering a Substantial Change in Earth Characteristic and Measuring Earth Changes (U.S. 4,042,196).

A. PERRILLIAT.
 METHOD OF BUILDING LEVEES AND EMBANKMENTS.
 APPLICATION FILED OCT. 14, 1915.

1,279,150.

Patented Sept. 17, 1918.

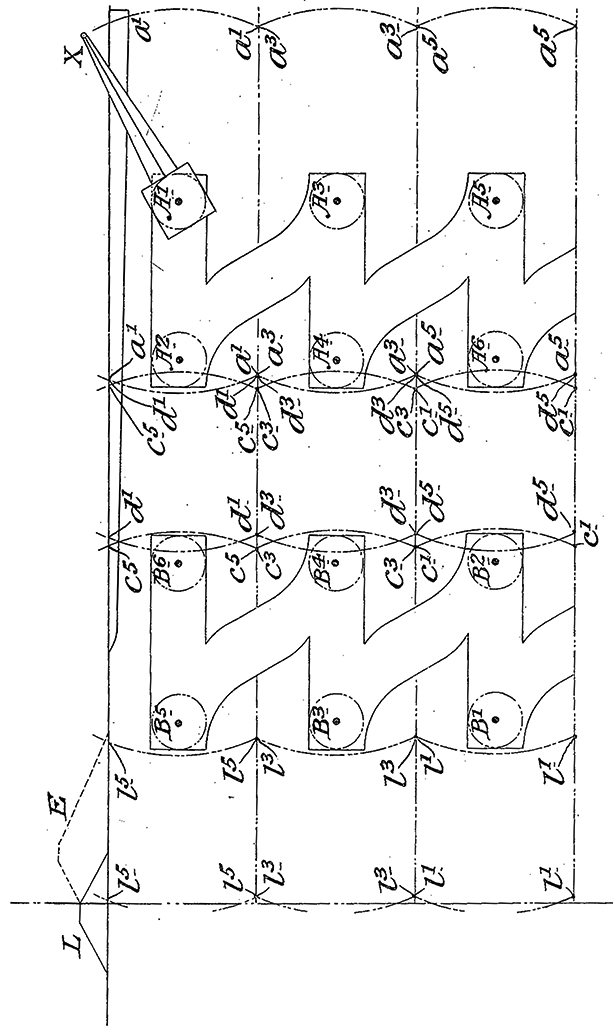

Inventor
 Arsène Perrilliat

By his Attorney

E. M. Bentley

2a: Arsène Perilliat, "Method of Building Levees and Embankments" (U.S. 1,279,150).

Figures 2a–f: The built environment is often represented in patent documents as a siteless series of typological conditions, material assemblages, processes, and methodologies. The patents shown here disclose inventions for (2a) choreographing earth moving and building levees, (2b) constructing unique water/terrestrial edge conditions (U.S. 5,678,954), (2c) controlling the ecological flow of water and sediment (U.S. 2014/0042064), (2d) utilizing data for placemaking (U.S. 2014/0324395), (2e) evaluating sustainability (U.S. 2011/0047086), and (2f) generating urban form (U.S. 2009/0070131). They are siteless, yet potentially impact the built environment.



US005678954A

United States Patent [19]

[11] Patent Number: **5,678,954**

Bestmann

[45] Date of Patent: ***Oct. 21, 1997**

[54] ECOLOGICAL COIR ROLL ELEMENT AND SHORELINE PROTECTED THEREBY

FOREIGN PATENT DOCUMENTS

39173577 5/1989 Germany

[76] Inventor: **Lothar Bestmann**, Pinneberger, Strasse 203, D-2000 Wedel/Holst, Germany

OTHER PUBLICATIONS

[*] Notice: The term of this patent shall not extend beyond the expiration date of Pat. No. 5,425,597.

Bestmann, Lothar, *Water and Soil*, "Praktische Verwendung lebender Baustoffe und technische Möglichkeiten", Year 36, vol. 1, Jan., 1984.

Hoeger, Sven, *Soil and Water Conservation*, "Schwimmkampen—Germany's artificial floating islands", vol. 43, No. 4, Jul.—Aug., 1988, pp. 304—306.

[21] Appl. No.: **448,680**

Bestmann, Lothar, outline of presentation to U.S. Army Corps of Engineers, Lake Eufula, OK, Apr., 1990.

[22] Filed: **May 24, 1995**

Bestmann, Lothar, "Biological Engineering Methods of Shore Protection", Apr., 1991.

Related U.S. Application Data

Bestmann Green Systems, "Bioengineering for Erosion Control, Water Quality, and Habitat Restoration", Feb., 1992.

[60] Continuation of Ser. No. 225,584, May 10, 1994, Pat. No. 5,425,597, which is a division of Ser. No. 43,272, Apr. 6, 1993, Pat. No. 5,338,131, which is a continuation-in-part of Ser. No. 886,693, May 21, 1992, abandoned.

Bestmann Green Systems, "Bioengineering with Bestmann Green Systems", Mar., 1992.

[30] Foreign Application Priority Data

Goldsmith, Wendi, *Land and Water*, "Working with Nature to Stabilize Shorelines", Nov./Dec., 1991.

Mar. 24, 1992 [EP] European Pat. Off. 92105015

Primary Examiner—Dennis L. Taylor

[51] Int. Cl.⁶ **F02B 3/12**

Attorney, Agent, or Firm—Richard P. Crowley

[52] U.S. Cl. **405/24; 405/16; 405/21**

[58] Field of Search 405/16, 15, 21, 405/24, 31—35; 47/665

[57] ABSTRACT

[56] References Cited

U.S. PATENT DOCUMENTS

486,887	11/1892	Neale	405/16
855,584	6/1907	Neale	405/16
909,423	1/1909	Keller	405/16
2,201,279	5/1940	Willing	405/16
2,264,973	12/1941	Guarino	47/66 S X
4,002,034	1/1977	Muhring et al.	405/19

An ecological fiber roll element for use in protecting a shoreline to prevent erosion and to the protected shoreline. The roll element comprises a generally cylindrical roll, with or without aquatic plants therein, the roll element consisting essentially of coir material. The roll element includes a netting material about the exterior surface of the roll. A plurality of the roll elements are arranged on a shoreline and secured usually by stakes to the shoreline.

27 Claims, 8 Drawing Sheets

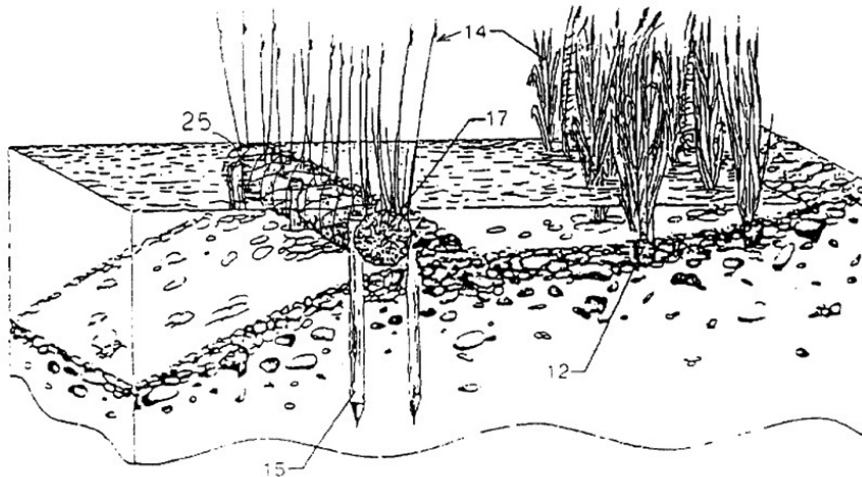



US 20140042064A1

(19) **United States**

(12) **Patent Application Publication**
Byeon

(10) **Pub. No.: US 2014/0042064 A1**

(43) **Pub. Date: Feb. 13, 2014**

(54) **ECOLOGICAL BIOTOPE WATER PURIFICATION SYSTEM UTILIZING A MULTI-CELL AND MULTI-LANE STRUCTURE OF A CONSTRUCTED WETLAND AND SEDIMENTATION POND**

(52) **U.S. Cl.**
CPC *C02F 3/327* (2013.01)
USPC **210/170.01**

(57) **ABSTRACT**

The present invention provides an ecological biotope water purification system utilizing multi-cells and multi-lanes by considering the width, length, curvature and slope of proposed composition site wetland and pond. The system comprising: a sedimentation pond (200, 200') for temporarily storing wastewater incoming from an Inlet (100,100'); a marsh (300, 300') incoming the primarily treated water, being precipitated solid contaminants, and discharged from the sedimentation pond (200, 200'), and at least one Multi-level cell composed an open water-surface pond (400, 400') entering the primarily treated water from the marsh; a settling reservoir (600, 600') outflow finally purified water by multi-level cell inflow for temporarily storing through outlet (700, 700'), the multi-level cell consists at least of two multi-lanes (40, 40', 40''), each lane is separated by small dikes (900, 900'). The present invention has advantage to compose the suitable wetland and pond on the proposed land by considering the geographic situation of site width, length, curvature and slope. Thus, it is possible to maximize the flexible design.

(76) Inventor: **Chanwoo Byeon, Seongnam (KR)**

(21) Appl. No.: **14/112,925**

(22) PCT Filed: **Jun. 19, 2012**

(86) PCT No.: **PCT/KR12/04844**

§ 371 (c)(1),
(2), (4) Date: **Oct. 19, 2013**

Related U.S. Application Data

(63) Continuation of application No. PCT/KR2012/004844, filed on Jun. 19, 2012.

Publication Classification

(51) **Int. Cl.**
C02F 3/32 (2006.01)

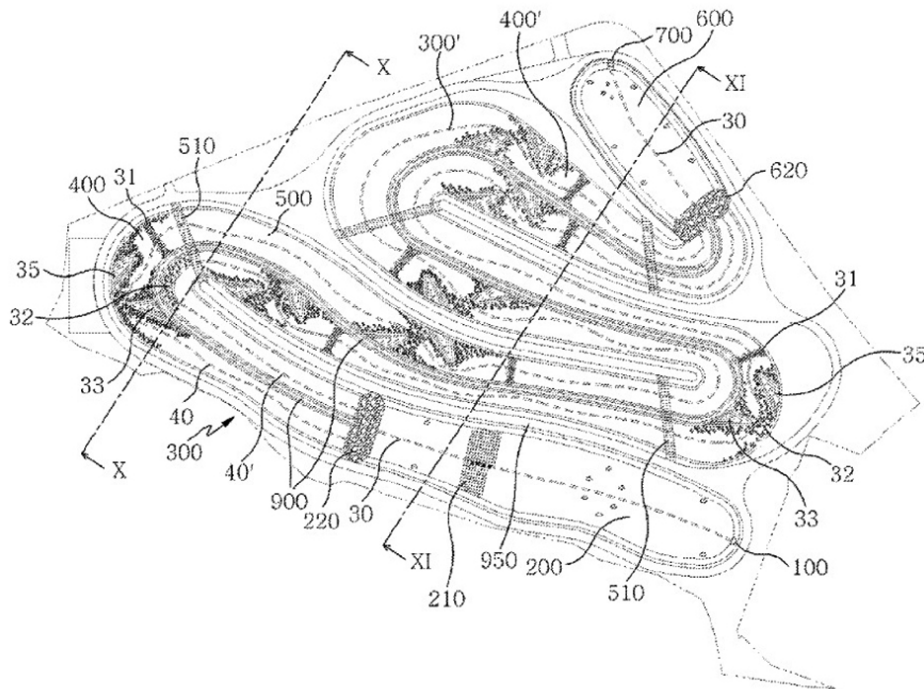



US 20140324395A1

(19) **United States**

(12) **Patent Application Publication**
Silverman et al.

(10) **Pub. No.: US 2014/0324395 A1**

(43) **Pub. Date: Oct. 30, 2014**

(54) **DATA DRIVEN PLACEMAKING**

Publication Classification

(71) Applicants: **David Silverman**, Boston, MA (US);
Salil Patel, Houston, TX (US); **Anthony Frausto-Robledo**, Marblehead, MA (US)

(51) **Int. Cl.**
G06F 17/50 (2006.01)
G06N 5/04 (2006.01)

(72) Inventors: **David Silverman**, Boston, MA (US);
Salil Patel, Houston, TX (US); **Anthony Frausto-Robledo**, Marblehead, MA (US)

(52) **U.S. Cl.**
CPC . **G06F 17/50** (2013.01); **G06N 5/04** (2013.01)
USPC **703/1**

(57) **ABSTRACT**

The embodiments described herein relate to a modeling system that defines index categories and uses model variables for analyzing successful or non-successful implementation. Data Driven Placemaking (DDP) provides evidence-based support to stakeholders (including designers, decision makers, policy makers, academics, and community members) for the purposes of improving designs for cities (and groupings of city regions and subsets of urban regions), via the collection, storage, transformation, analysis, and visualization of data relating to index categories and model variables.

(21) Appl. No.: **13/889,427**

(22) Filed: **May 8, 2013**

Related U.S. Application Data

(60) Provisional application No. 61/644,062, filed on May 8, 2012.

ACCESS AND LINKAGES

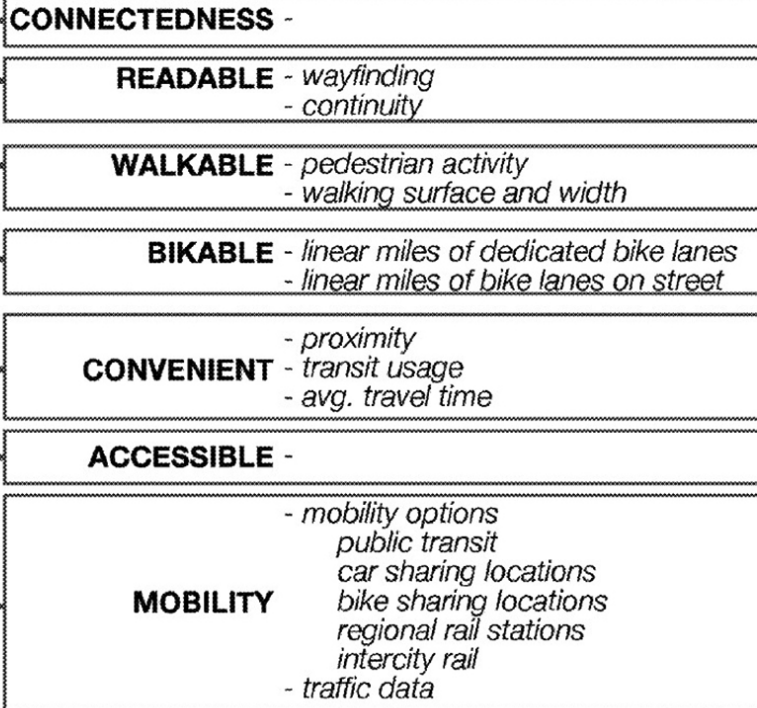



US 20110047086A1

(19) **United States**

(12) **Patent Application Publication**
Heisterkamp et al.

(10) **Pub. No.: US 2011/0047086 A1**

(43) **Pub. Date: Feb. 24, 2011**

(54) **EVALUATING ENVIRONMENTAL SUSTAINABILITY**

(75) Inventors: **Marc E. Heisterkamp**, Portland, OR (US); **Guy H. Volz**, Matthews, NC (US); **Wayne Santos**, Alpharetta, GA (US); **Robert G. Becker**, Charlotte, NC (US); **Robin Alexander**, Philadelphia, PA (US)

Correspondence Address:
BANNER & WITCOFF, LTD
ATTORNEYS FOR CLIENT NUMBER 007131
10 SOUTH WACKER DR., SUITE 3000
CHICAGO, IL 60606 (US)

(73) Assignee: **BANK OF AMERICA CORPORATION**, Charlotte, NC (US)

(21) Appl. No.: **12/894,610**

(22) Filed: **Sep. 30, 2010**

Related U.S. Application Data

(63) Continuation-in-part of application No. 11/939,852, filed on Nov. 14, 2007.

Publication Classification

(51) **Int. Cl.**
G06Q 50/00 (2006.01)

(52) **U.S. Cl.** **705/314**

(57) **ABSTRACT**

A system and method may automatically receive an electronic lease or other agreement document for property and parse the document to identify provisions provided therein. The lease may then be evaluated for various types of provisions to determine an overall quality score. In one example, the quality score may correspond to an environmental sustainability score and include considerations such as sub-metering, water-saving fixtures, LEED certification and the like. In one or more arrangements, provisions may be identified by generating and providing an electronic questionnaire through which a user may specify the applicable terms of the lease. Approval of the lease may be conditioned on a minimum environmental sustainability score as determined by the lease provisions. A system may further suggest ways to improve the environmental sustainability score.

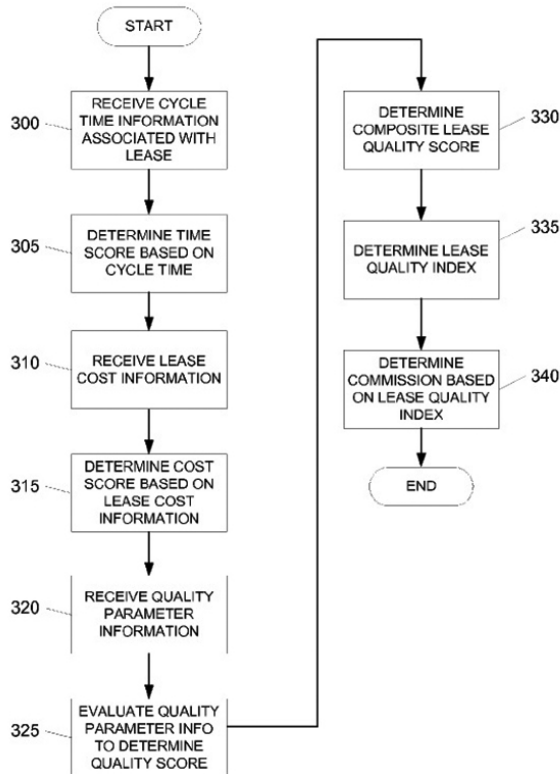



US 20090070131A1

(19) **United States**

(12) **Patent Application Publication**
Chen

(10) **Pub. No.: US 2009/0070131 A1**

(43) **Pub. Date: Mar. 12, 2009**

(54) **STANDARDIZED URBAN PRODUCT**

Publication Classification

(76) Inventor: **Lin Chen, Hefei (CN)**

(51) **Int. Cl.**
G06Q 10/00 (2006.01)
E04B 1/00 (2006.01)

(52) **U.S. Cl.** **705/1; 52/741.1**

Correspondence Address:
HOFFMANN & BARON, LLP
6900 JERICHO TURNPIKE
SYOSSET, NY 11791 (US)

(57) **ABSTRACT**

(21) Appl. No.: **12/159,683**

A mesh-sheet standardized block module includes a standardized house module, an animal/plant type house artistic module, or other building, and a mesh-sheet standardized block underground space module. The mesh-sheet standardized block module further includes a net-like standardized road/bridge module and a net-like standardized canal module, and may be replicated and assembled to form a standardized urban product with a required scale. The standardized urban product has a scientific layout, appropriate function, fresh air, exquisite landscape, and fluent traffic. Moreover, due to its high efficiency and low cost, the standardized urban product has significant economic benefits, and may create a profit of 20,000 billion US dollars, and provide plenty of jobs. In addition the criteria and methods for manufacturing a standardized urban product with no traffic jam, but exquisite environment, low price, and commodity house markets in various prices are provided through technical schemes for countries with water sources such as China, the USA, India, and Nigeria.

(22) PCT Filed: **Jun. 27, 2006**

(86) PCT No.: **PCT/CN2006/001469**

§ 371 (c)(1),
(2), (4) Date: **Oct. 29, 2008**

(30) **Foreign Application Priority Data**

Dec. 29, 2005 (CN) 200510132878.1

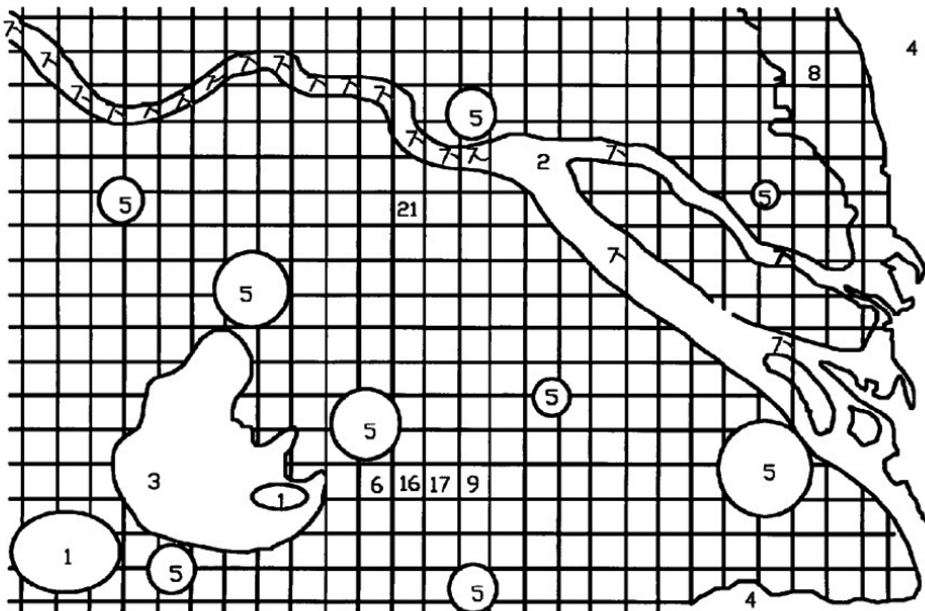

J. B. EADS & J. ANDREWS.

MATRASS FOR FORMING EMBANKMENT.

No. 170,832.

Patented Dec. 7, 1875

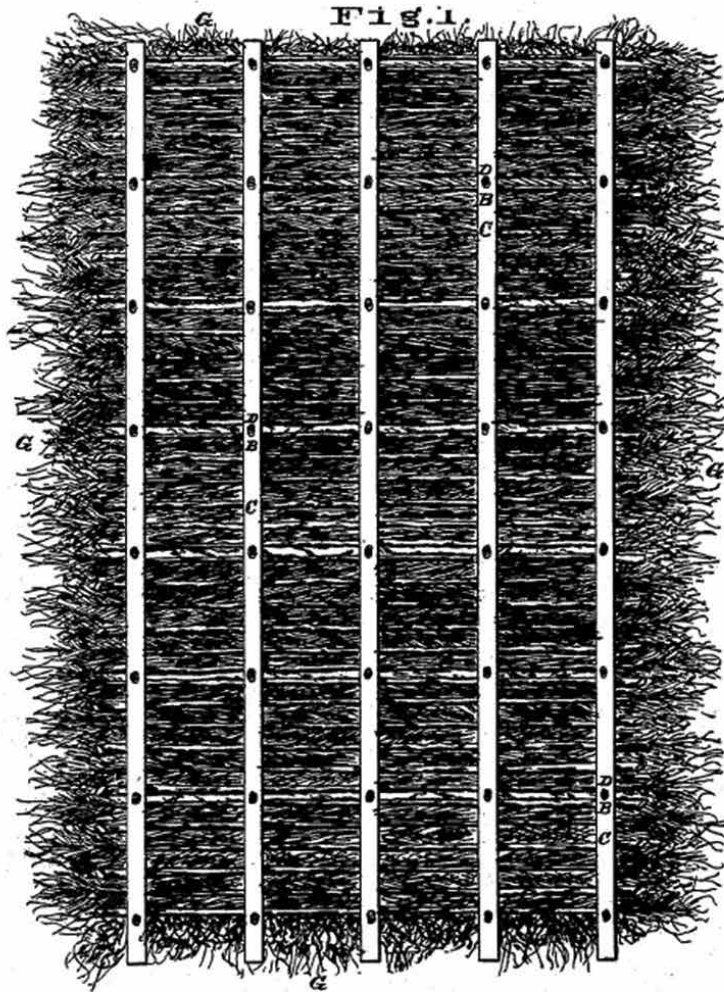

ATTEST:

Chas. J. Gooch
Leok Blond. Recorder

INVENTORS:

James B. Eads
James Andrews
By Knight
 Attorneys

3a: James Buchanan Eads and James Andrews, "Mattress for Forming Embankment" (U.S. 170,832), sheet 1 of 3; prototyped, tested, and installed at the South Pass of the Mississippi River.

J. B. EADS & J. ANDREWS.

MATRASS FOR FORMING EMBANKMENT.

No. 170,832.

Patented Dec. 7, 1875.

Fig. 2.

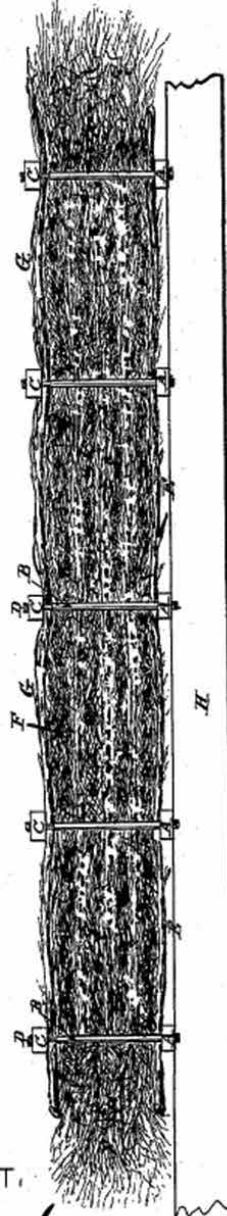
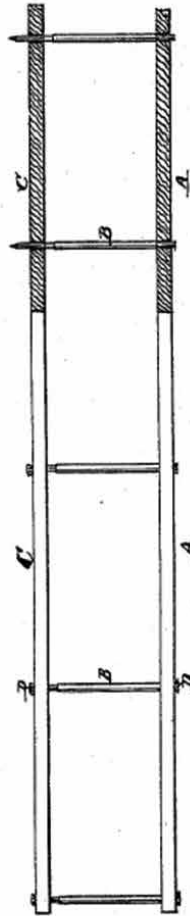

Fig. 3.



ATTEST,

Chas. J. Cochr
Wm. Bond Burdett

INVENTORS:

James B. Eads
James Andrews
By Knight & Co. Attorneys

J. B. EADS & J. ANDREWS.

MATRASS FOR FORMING EMBANKMENT.

No. 170,832.

Patented Dec. 7, 1875.

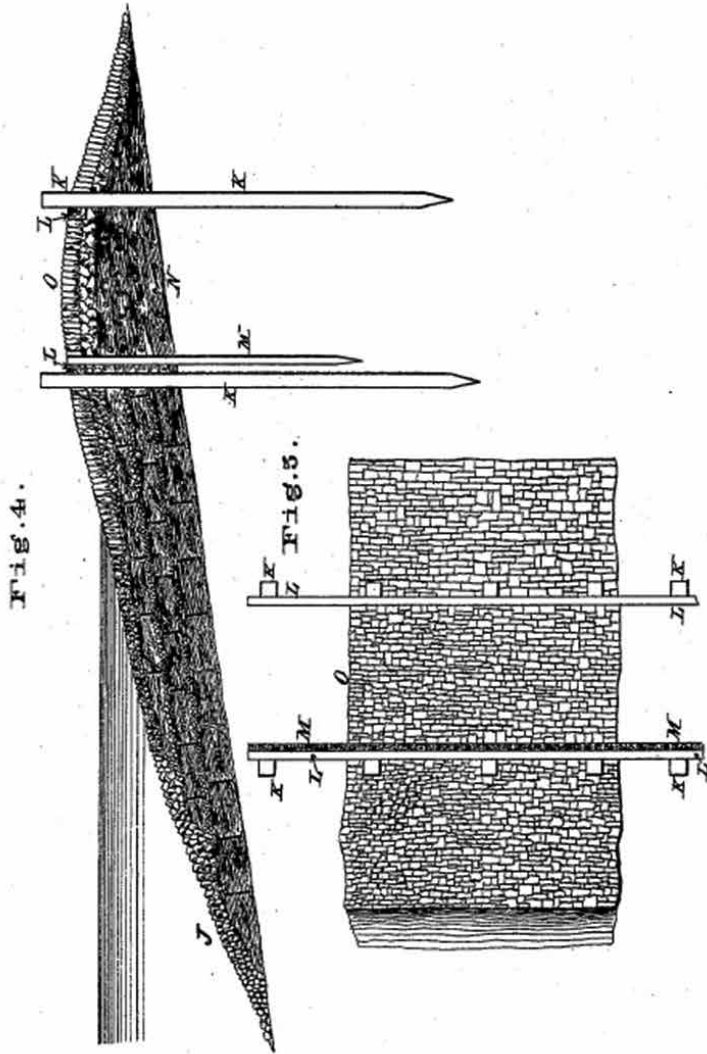

ATTEST:

Chas. Gooch
Not. Public

INVENTORS:

James B. Eads.
James. Andrews.
D. Wright Bros
Attorneys.

Dec. 14, 1937.

W. K. HARRISON ET AL
MODEL OF AN ARCHITECTURAL UNIT

Des. 107,425

Filed Aug. 10, 1937

2 Sheets-Sheet 1

Fig. 1.

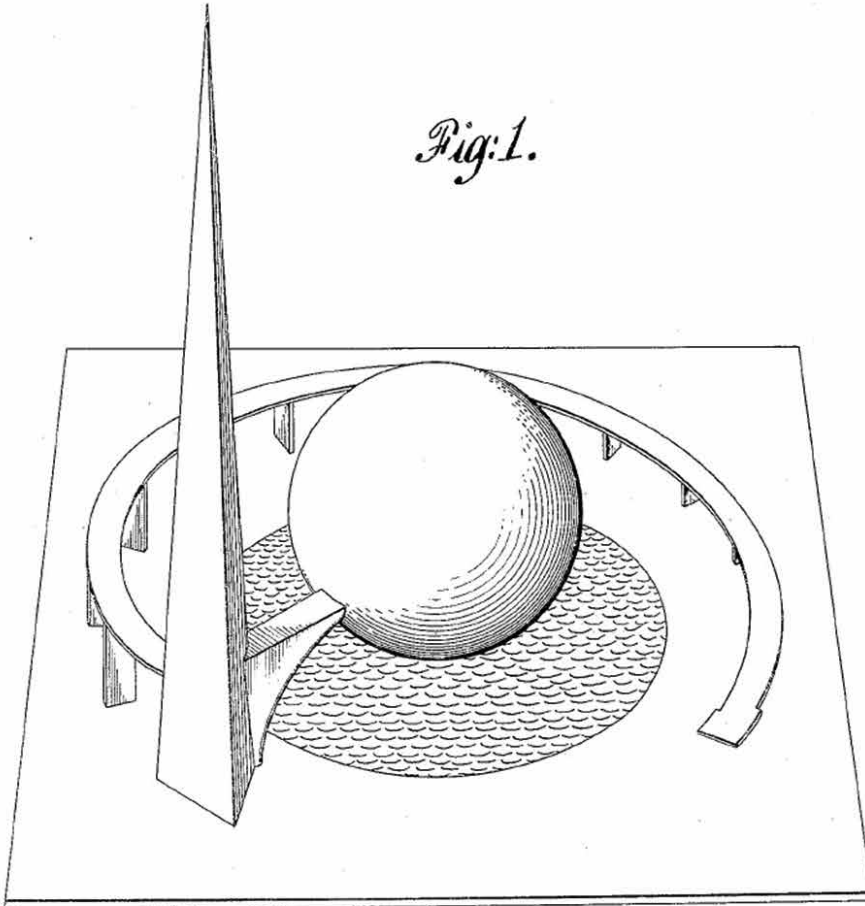

INVENTORS
WALLACE K. HARRISON
J. ANDRE FOUILHOUX
BY *William Barnes*
ATTORNEY

4a: Wallace K. Harrison et al., "Model of an Architectural Unit" (U.S. Des. 107,425), a patent limiting replication of the form of the Trylon and Perisphere designed and built as a central feature of the New York World's Fair (1939-1940), sheet 1 of 2.

Dec. 14, 1937.

W. K. HARRISON ET AL

Des. 107,425

MODEL OF AN ARCHITECTURAL UNIT

Filed Aug. 10, 1937

2 Sheets-Sheet 2

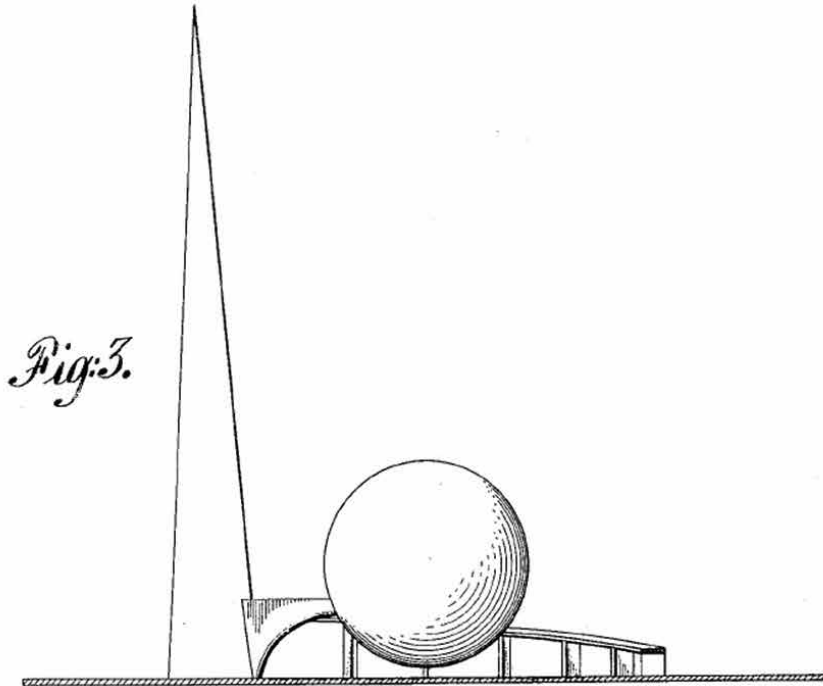

Fig. 3.

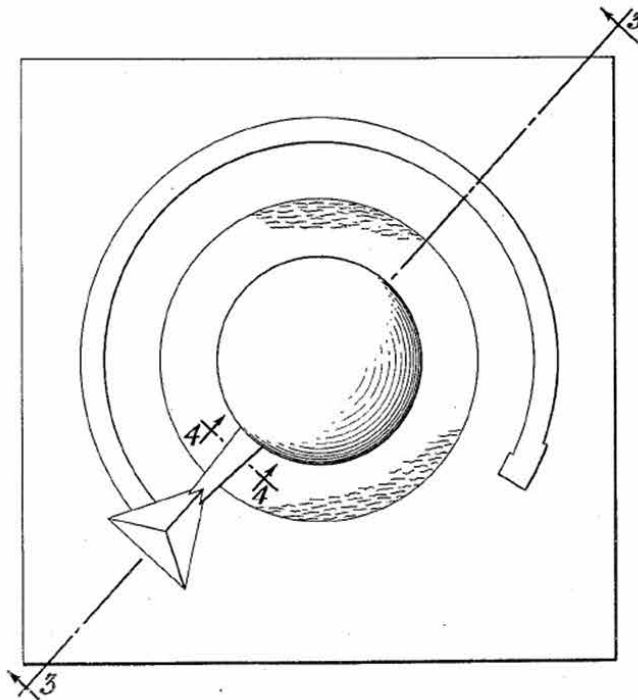

Fig. 2.

Fig. 4.



INVENTORS
WALLACE K. HARRISON
J. ANDRE FOUILHOX
BY *William J. Barnes*
ATTORNEY



US00D712067S

(12) **United States Design Patent**
Backus et al.

(10) **Patent No.:** **US D712,067 S**
(45) **Date of Patent:** **** Aug. 26, 2014**

- (54) **BUILDING**
- (71) Applicant: **Apple Inc.**, Cupertino, CA (US)
- (72) Inventors: **Karl Backus**, Emeryville, CA (US);
Peter Bohlin, Waverly, PA (US); **Robert Bridger**, Woodside, CA (US); **Benjamin L. Fay**, Palo Alto, CA (US); **Ronald Bruce Johnson**, Cupertino, CA (US); **James O'Callaghan**, Winchester (GB); **Steve P. Jobs**, Palo Alto, CA (US)

- (73) Assignee: **Apple Inc.**, Cupertino, CA (US)
- (**) Term: **14 Years**
- (21) Appl. No.: **29/434,596**
- (22) Filed: **Oct. 15, 2012**
- (51) **LOC (10) Cl.** **25-03**
- (52) **U.S. Cl.** **D25/32**
USPC **D25/32**
- (58) **Field of Classification Search**
USPC D25/1-35; 52/2.17, 2.25, 86, 65, 66,
52/67, 71, 72, 80, 82
See application file for complete search history.

(56) **References Cited**

U.S. PATENT DOCUMENTS

3,562,972	A *	2/1971	D'Amato	52/66
D296,934	S *	7/1988	Sosno et al.	D25/5
5,007,215	A	4/1991	Minter		
D327,744	S *	7/1992	Francis	D25/1
5,140,790	A *	8/1992	Modglin et al.	52/81.4
D648,864	S	11/2011	Backus et al.		
D656,240	S *	3/2012	Andreini et al.	D25/31
D659,853	S *	5/2012	Backus et al.	D25/18

D688,387	S *	8/2013	Park et al.	D25/33
8,584,404	B2 *	11/2013	Heidenreich	52/79.5
2012/0090251	A1 *	4/2012	Andreini et al.	52/81.6
2012/0096777	A1 *	4/2012	Backus et al.	52/80.1

OTHER PUBLICATIONS

Bohlin, Cywinski, Jackson, "Apple Store Fifth Avenue, New York."(<http://www.galinsky.com/buildings/applefifthavenue/index.html>) accessed Nov. 2, 2012, 4 pages.
"New Glass Technology Is Behind Cube Replacement," ifoAppleStore.com/ (<http://www.ifoapplestore.com/2011/08/09/new-glass-technology-is-behind-cube-replacement/>) dated Aug. 9, 2011, accessed Jun. 28, 2013, 12 pages.

* cited by examiner

Primary Examiner — Eric Goodman

(74) *Attorney, Agent, or Firm* — Sterne, Kessler, Goldstein & Fox P.L.L.C.

(57) **CLAIM**

The ornamental design for a building, as shown and described.

DESCRIPTION

FIG. 1 is a top front perspective view of a building showing our new design;
FIG. 2 is a front view thereof;
FIG. 3 is a rear view thereof;
FIG. 4 is a right side view thereof;
FIG. 5 is a left side view thereof; and,
FIG. 6 is a top view thereof.
The broken lines in the Figures show portions of the building and environment which form no part of the claimed design. The oblique lines in the Figures show transparency and not surface ornamentation.

1 Claim, 6 Drawing Sheets

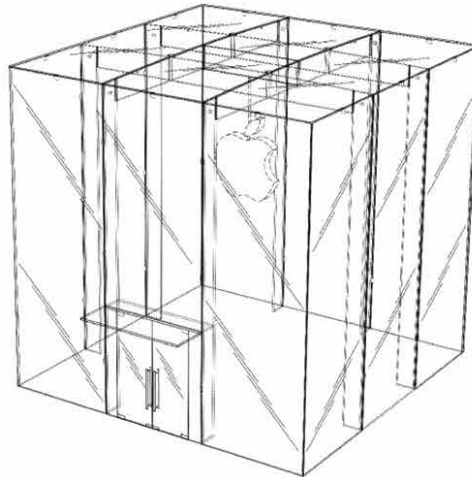

4c: Apple Inc., "Building" (U.S. D712,067), a patent protecting the design of Apple Stores from replication, based on the flagship store on Fifth Avenue in New York City. Design patents protect form and appearance; utility patents protect the function and configuration of an invention.

No. 833,544.

PATENTED OCT. 16, 1906.

J. W. PARKER.
METHOD OF CLEANSING HARBORS.
APPLICATION FILED JULY 24, 1905.

3 SHEETS—SHEET 1.

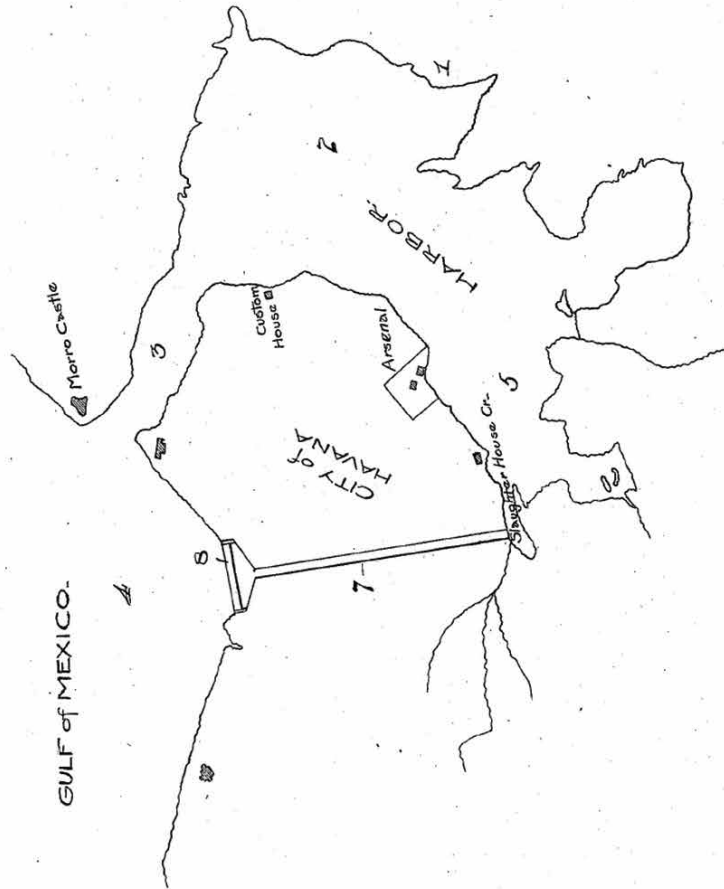

Witnesses
D. L. ...
M. H. Yates

Fig. 1.

Inventor
John W. Parker,
By Joseph ...
Attorney

5a: John W. Parker, "Method of Cleaning Harbors," sited in Havana, Cuba (U.S. 833,544).

THE MORRIS PATRICK CO., WASHINGTON, D. C.

Figures 5a-e: Patent cartographies situate technological innovations within known geographical locations. Examples of environmental and technological innovation in patent documents include (5a) "Method of Cleaning Harbors," sited in Havana, Cuba; (5b) "Device for Utilizing the Water Power of Falls," sited at Niagara Falls, New York; (5c) "Submarine Wall," sited in Galveston Bay; (5d) a method of "Obstructing Ice in Rivers and Harbors," sited in New York City; and (5e) "Method and apparatus for coastline remediation, energy generation, and vegetation support," sited in global mangrove ecosystems.

(No Model.)

5 Sheets—Sheet 1.

C. J. ZEITINGER.

DEVICE FOR UTILIZING THE WATER POWER OF FALLS.

No. 442,000.

Patented Dec. 2, 1890.

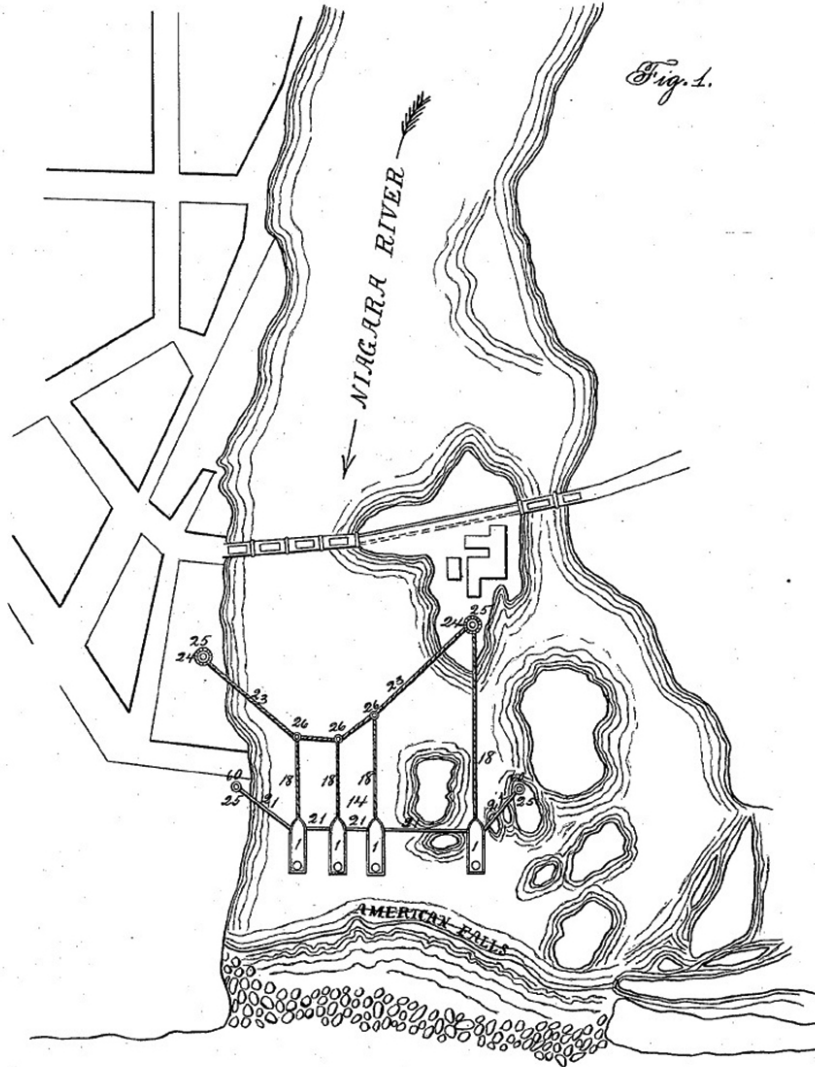

Witnesses:
J. G. Potter
f. A. Downing

By

Inventor:
Christian J. Zeitinger
Knights & Co.
Attorneys.

(No Model.)

3 Sheets—Sheet 1.

D. SPANGLER.
SUBMARINE WALL.

No. 325,127.

Patented Aug. 25, 1885.

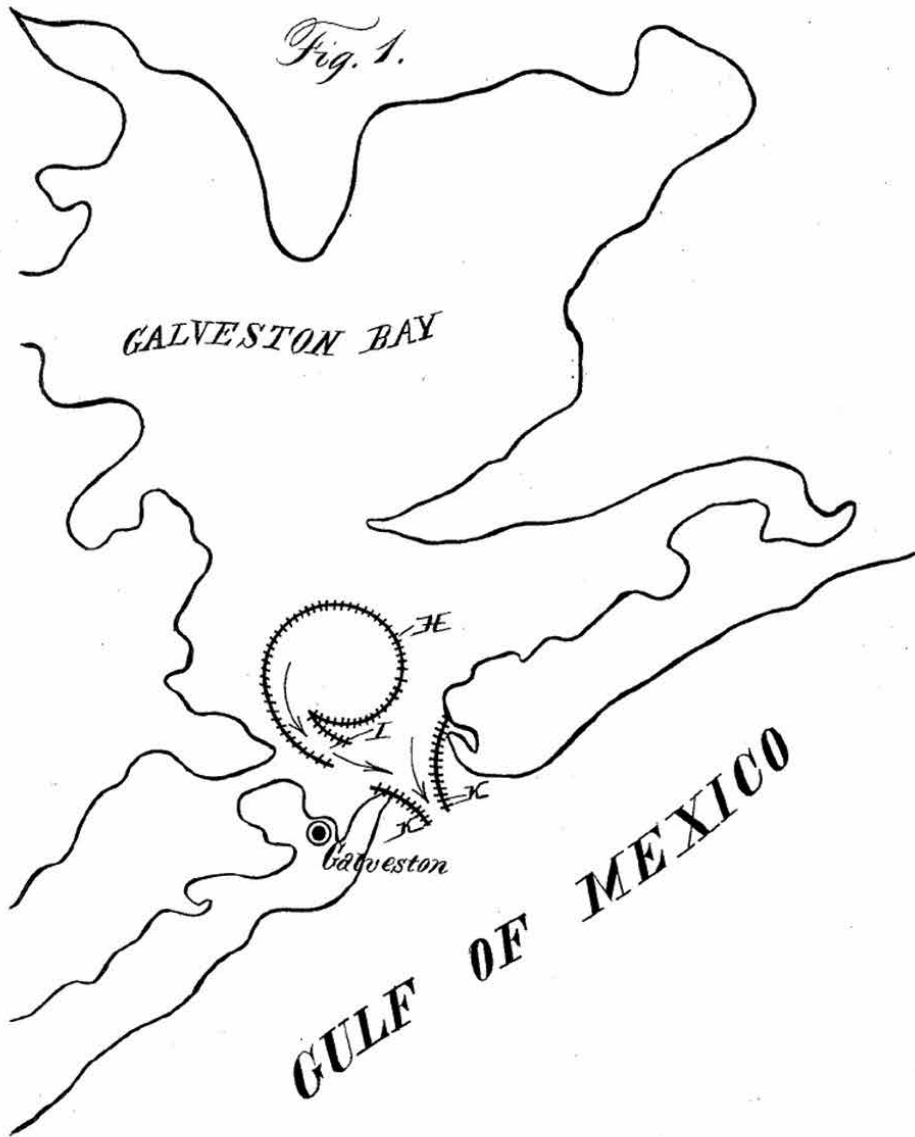

Witnesses
Wm. S. Denton
H. O. M. Cummins

Inventor
Daniel Spangler.
By *Louis Bagger Co.*
attorneys

P. Voorhis

Obstructing Ice in Rivers and Harbors.

N^o 63,968.

Patented Apr. 16, 1867.

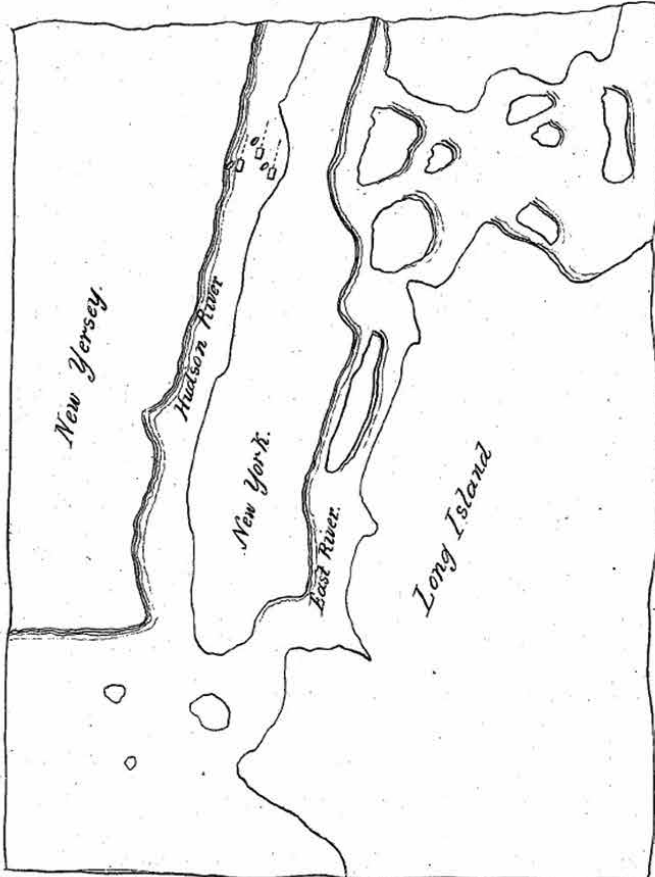
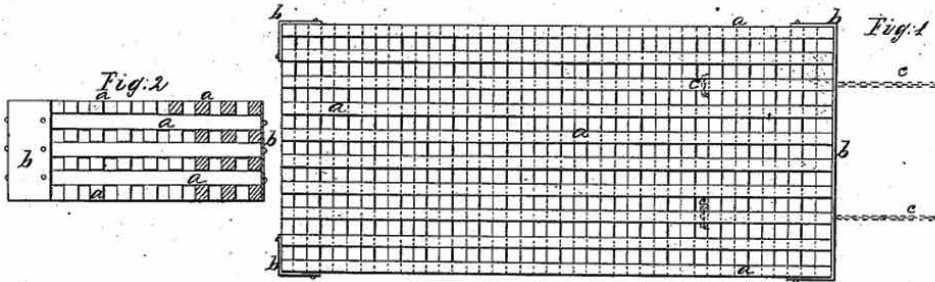

Witnesses
Charles Jew
John M. Fulger

Inventor
Peter Voorhis
By atty G. A. M. S. L. S.

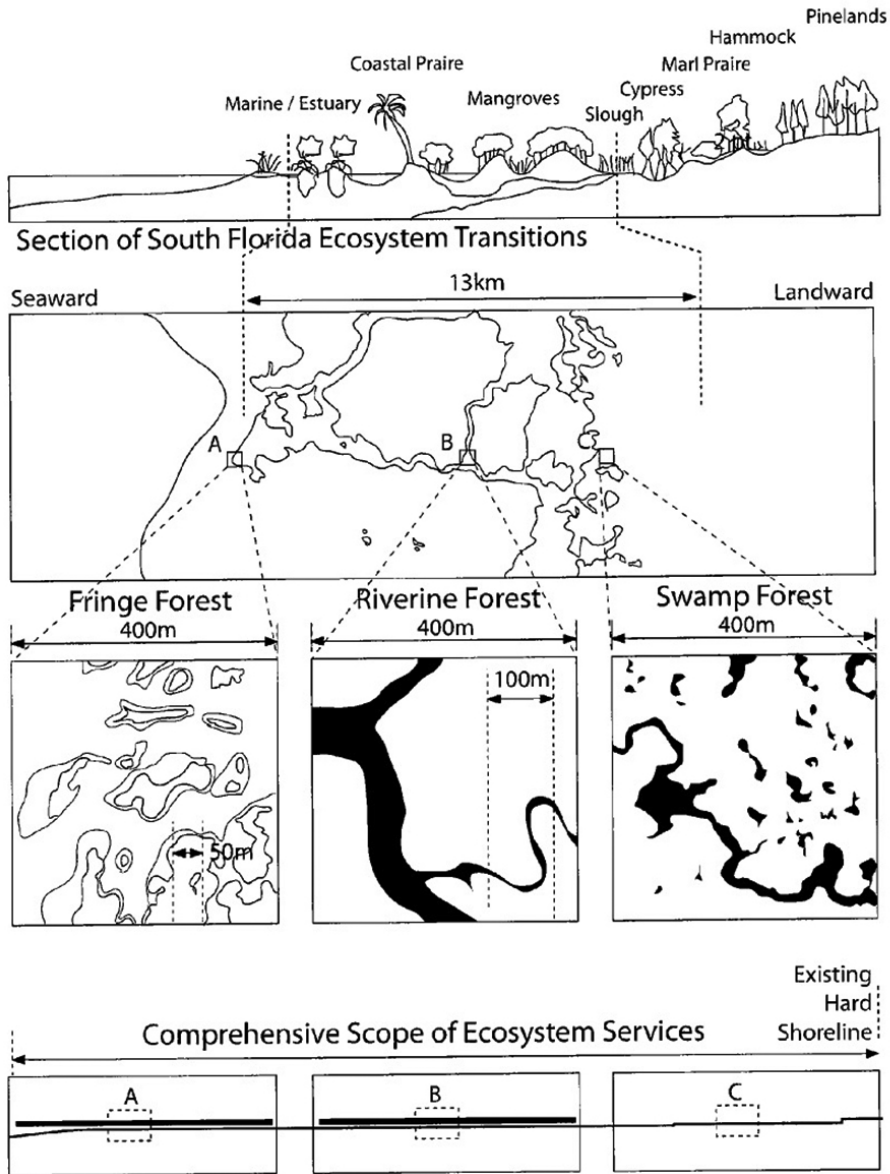

FIG. 4

5e: Keith Van de Riet, Jason Vollen, and Anna Dyson, Rensselaer Polytechnic Institute, "Method and apparatus for coastline remediation, energy generation, and vegetation support," sited in global mangrove ecosystems (U.S. 8,511,936).



PROBABLE CONDITION OF BAR TO BE EFFECTED BY THE COMPLETION OF THE REACTION BREAKWATER AND REMOVAL OF OBSTRUCTING JETTY.

6a: Lewis M. Haupt, model for the "reaction breakwater" as partially prototyped at Aransas Pass, Texas. Image: *Proceedings of the American Philosophical Society* 38: 160 (October 1899): 139, plate VIII.

Figures 6a-c: Lewis M. Haupt's patent for the "reaction breakwater," sited in Texas, Delaware/New Jersey, South Carolina, and partially prototyped at Aransas Pass, Texas. Professor Haupt received a Magellanic Award from the American Philosophical Society and a patent for a "Dike and Breakwater" from the United States Patent and Trademark Office (U.S. 380,569). Pictures of the design models show the before and after conditions of Aransas Pass.

(No Model.)

2 Sheets—Sheet 1.

L. M. HAUPT.

DIKE OR BREAKWATER.

No. 380,569.

Patented Apr. 3, 1888.

FIG. 1.

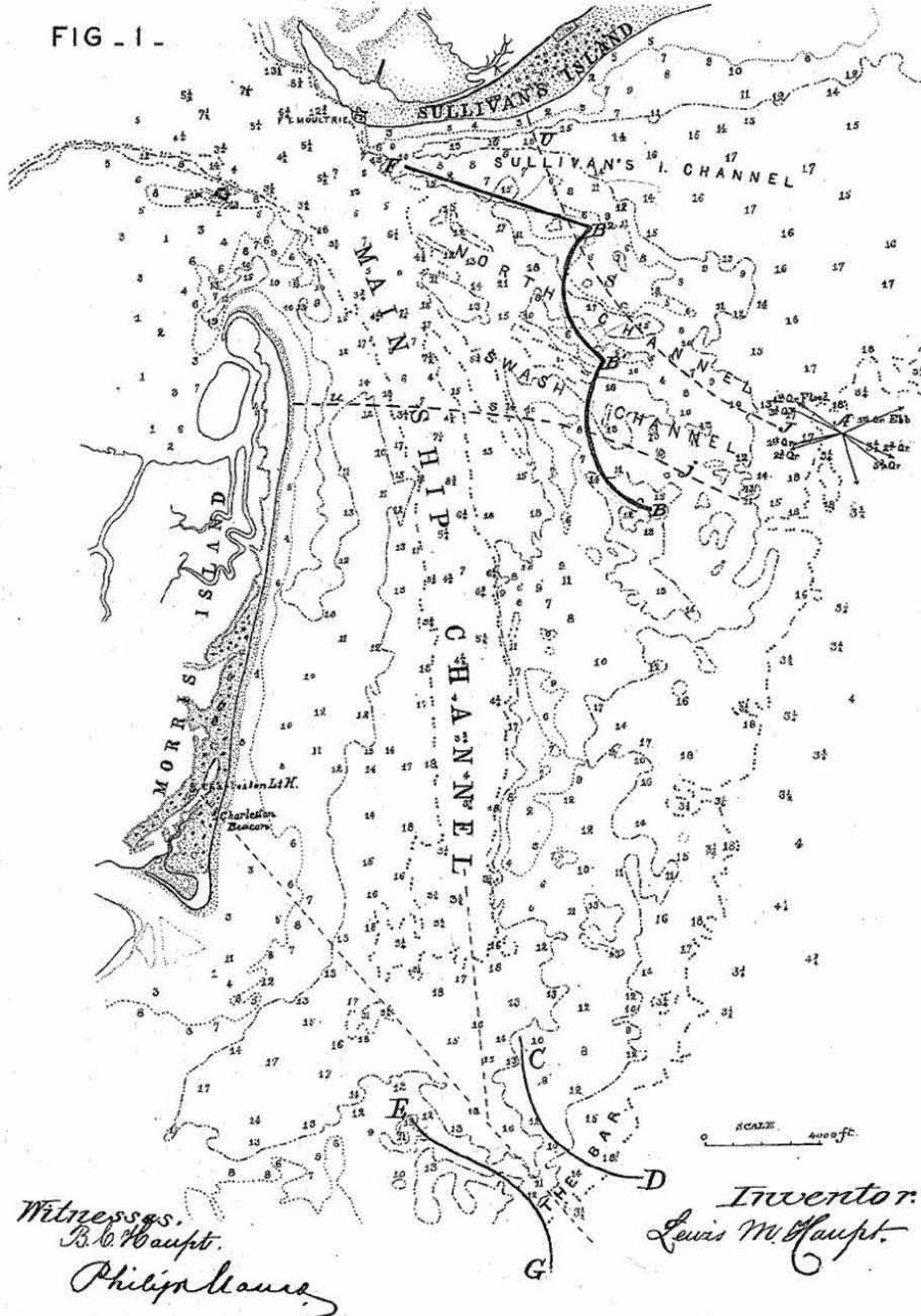

(No Model.)

2 Sheets—Sheet 2.

L. M. HAUPT.
DIKE OR BREAKWATER.

No. 380,569.

Patented Apr. 3, 1888.

FIG - II -

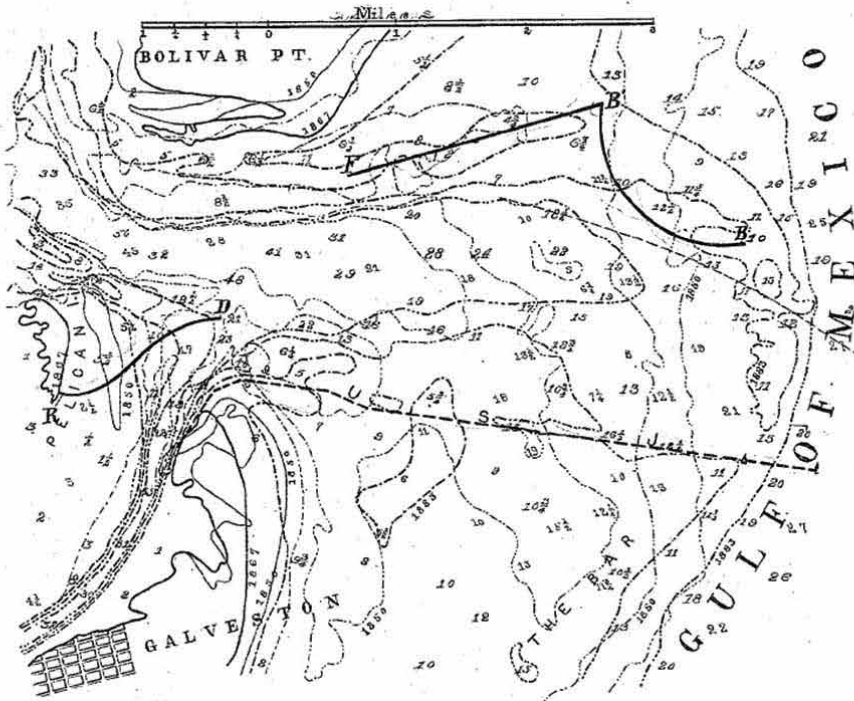
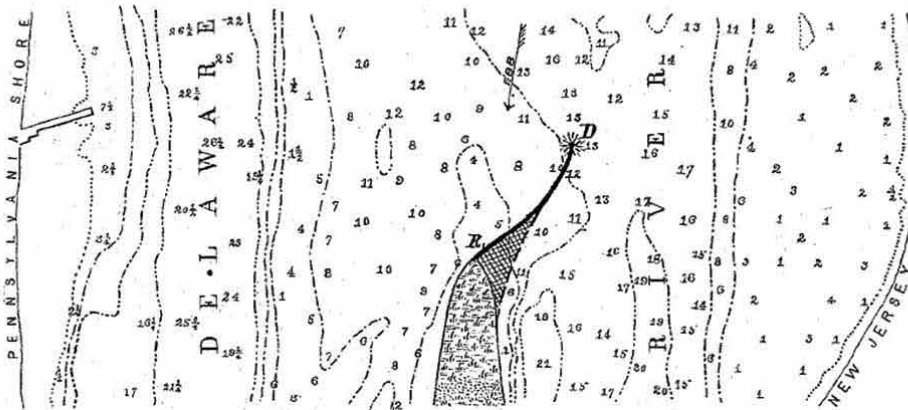

FIG - III -



Witnesses.
Philip Mauro
C. W. Beckham.

Inventor.
Lewis M. Haupt.
by A. Rollor, his attorney.

No. 687,307.

Patented Nov. 26, 1901.

L. M. HAUPT.
JETTY OR BREAKWATER.
Application filed Apr. 8, 1901.

(No Model.)

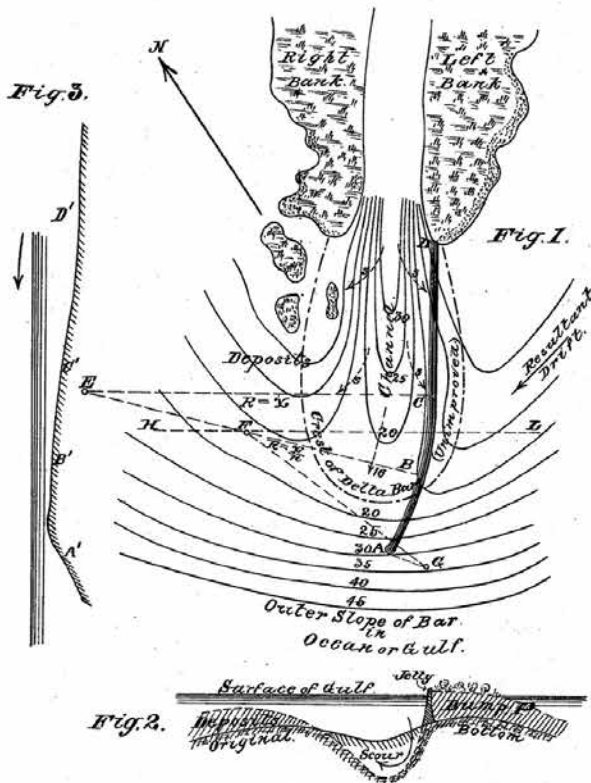

Witnesses.
H.R. Edlin.
A.R. Hankam

Inventor.
Lewis M. Haupt,
by Philip Havers,
his attorney.

THE NORMAN TYPE CO. PRINTERS, WASHINGTON, D.C.

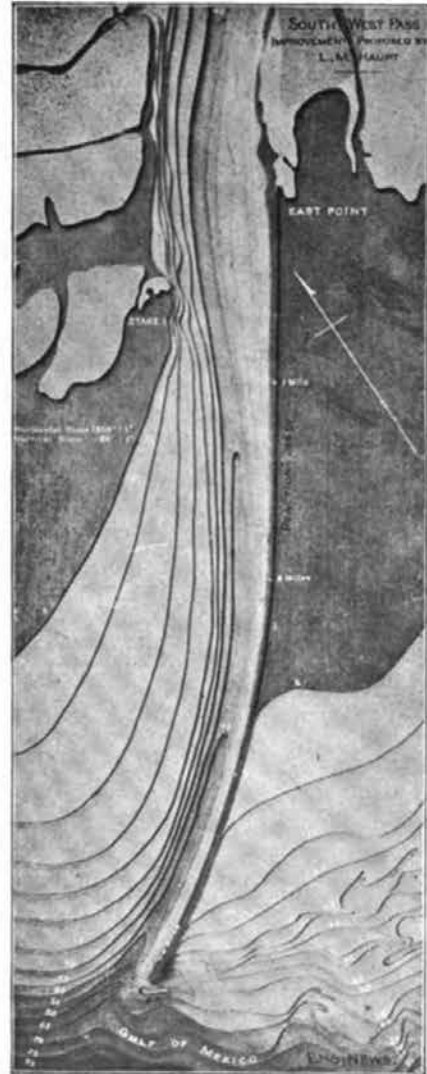

7: Lewis M. Haupt's site-specific patent for a "Jetty or Breakwater" at the Southwest Pass of the Mississippi River (U.S. 687,307) resulted from an adaptation of the "reaction breakwater" for the specific conditions of Mississippi. The design models show the resultant fluvial geomorphology of the patented design. Image: Lewis M. Haupt, "History of the Reaction Breakwater at Aransas Pass, Texas," *Journal of the Franklin Institute* 165: 2 (February 1908): 92, figure 5

A Medici Proposal for Navigable Channels in the Mississippi River Delta

Bathymetric forest

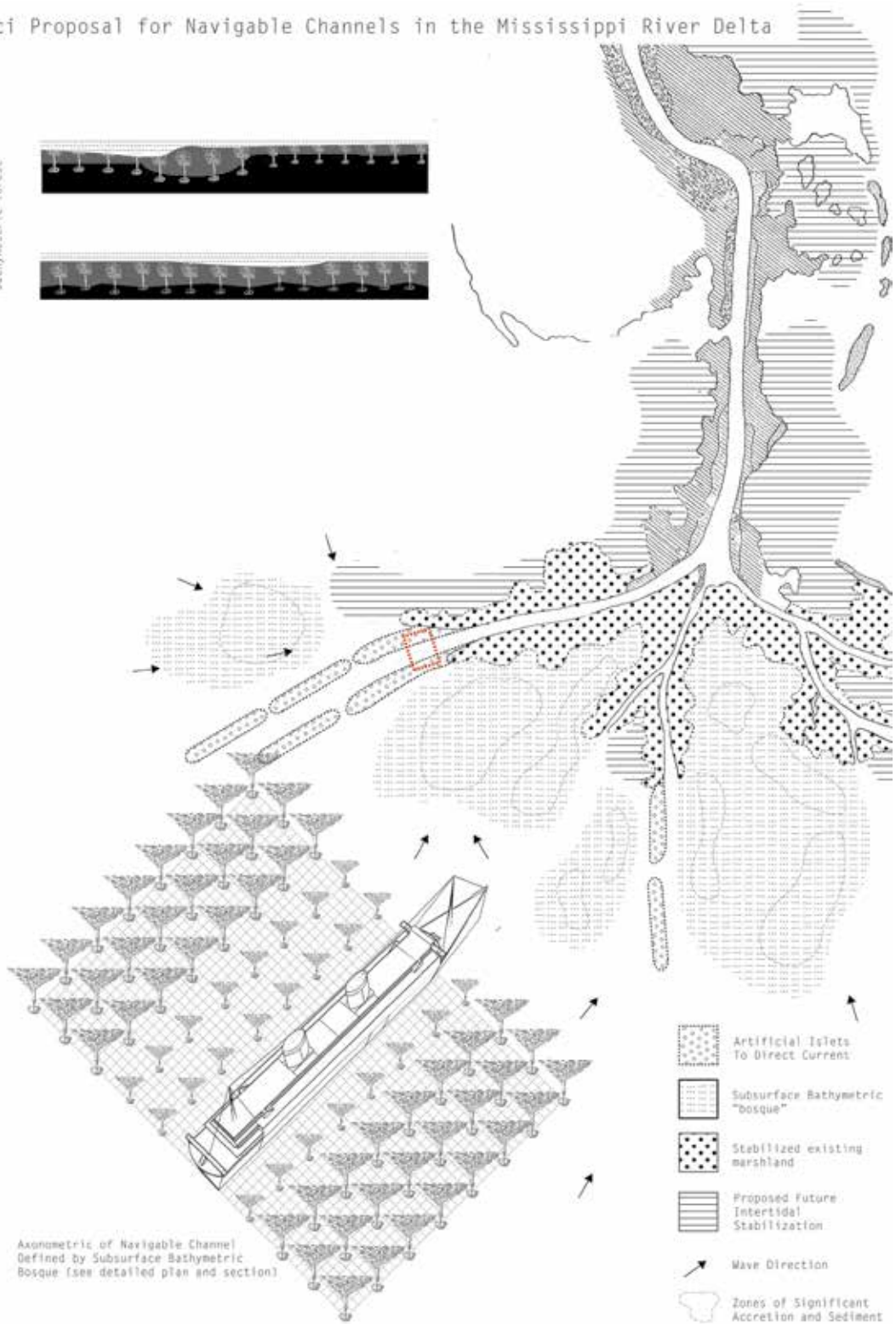
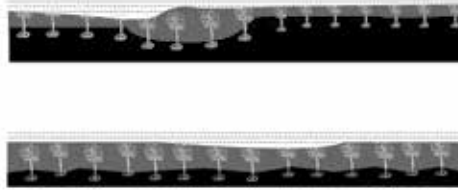

Axonometric of Navigable Channel Defined by Subsurface Bathymetric Bosque (see detailed plan and section)

8a: Richard L. Hindle, "A Medici Proposal for Navigable Channels in the Mississippi River Delta" (2015/2016), referencing Juan Bautista Medici, "System for Formation of Permanent Channels in Navigable Rivers" (U.S. 658,795). The drawing adapts the specifications of Medici's patent to the Mississippi's Heads of Passes, showing navigable channels created by artificial islets, and stabilization of the delta through a subsurface bathymetric bosque.

No. 658,795.

Patented Oct. 2, 1900.

J. B. MEDICI.

SYSTEM FOR FORMATION OF PERMANENT CHANNELS IN NAVIGABLE RIVERS.

(Application filed July 6, 1900.)

(No Model.)

2 Sheets—Sheet 1.

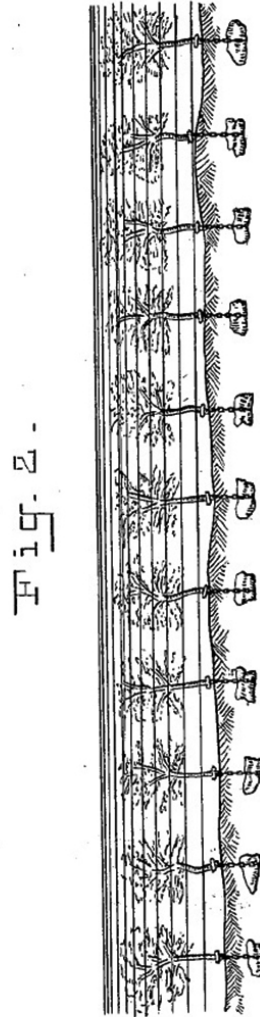
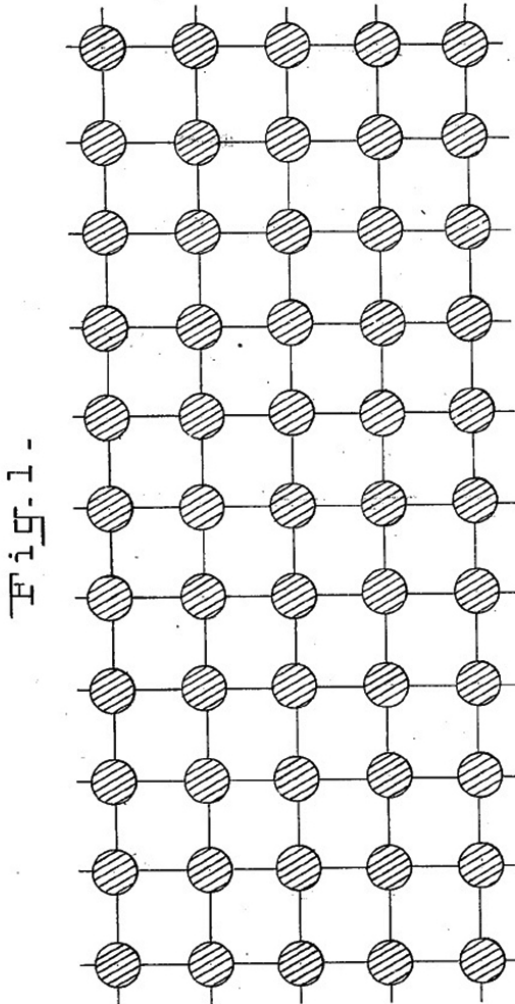

Witnesses:

E. B. Bolton
Ottomank

Inventor:

Juan Bautista Medici

By *Richard R.*
his Attorney.

J. B. MEDICI.

SYSTEM FOR FORMATION OF PERMANENT CHANNELS IN NAVIGABLE RIVERS.

(Application filed July 6, 1900.)

(No Model.)

2 Sheets—Sheet 2.

Fig. 4 -

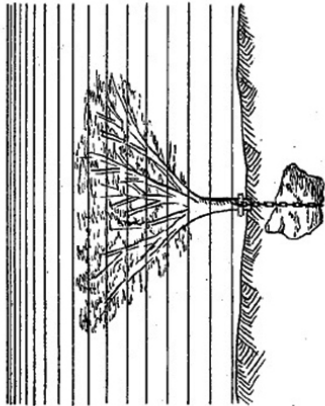

Fig. 3 -

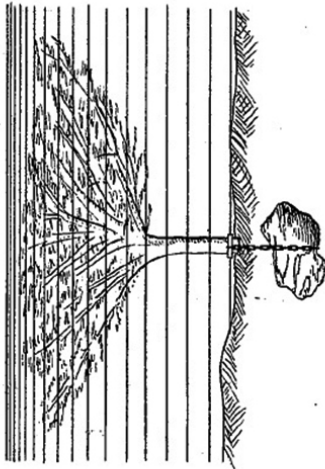
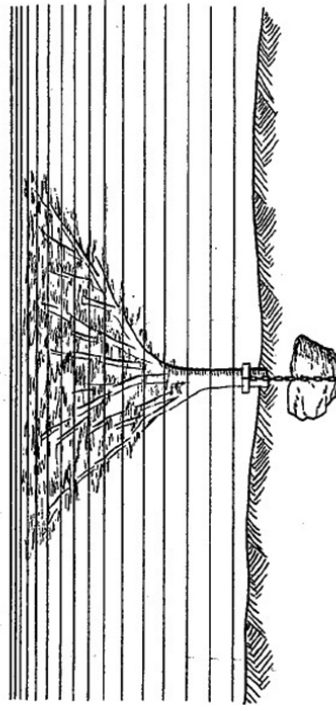

Fig. 5 -



Witnesses:
 E. B. Colton
 Ottomunk

Inventor:
 Juan Bautista Medici

By *Richard R.*

his Attorneys.

A Plan By Linus Brown to Protect Low-lying Riparian Lands of Louisiana

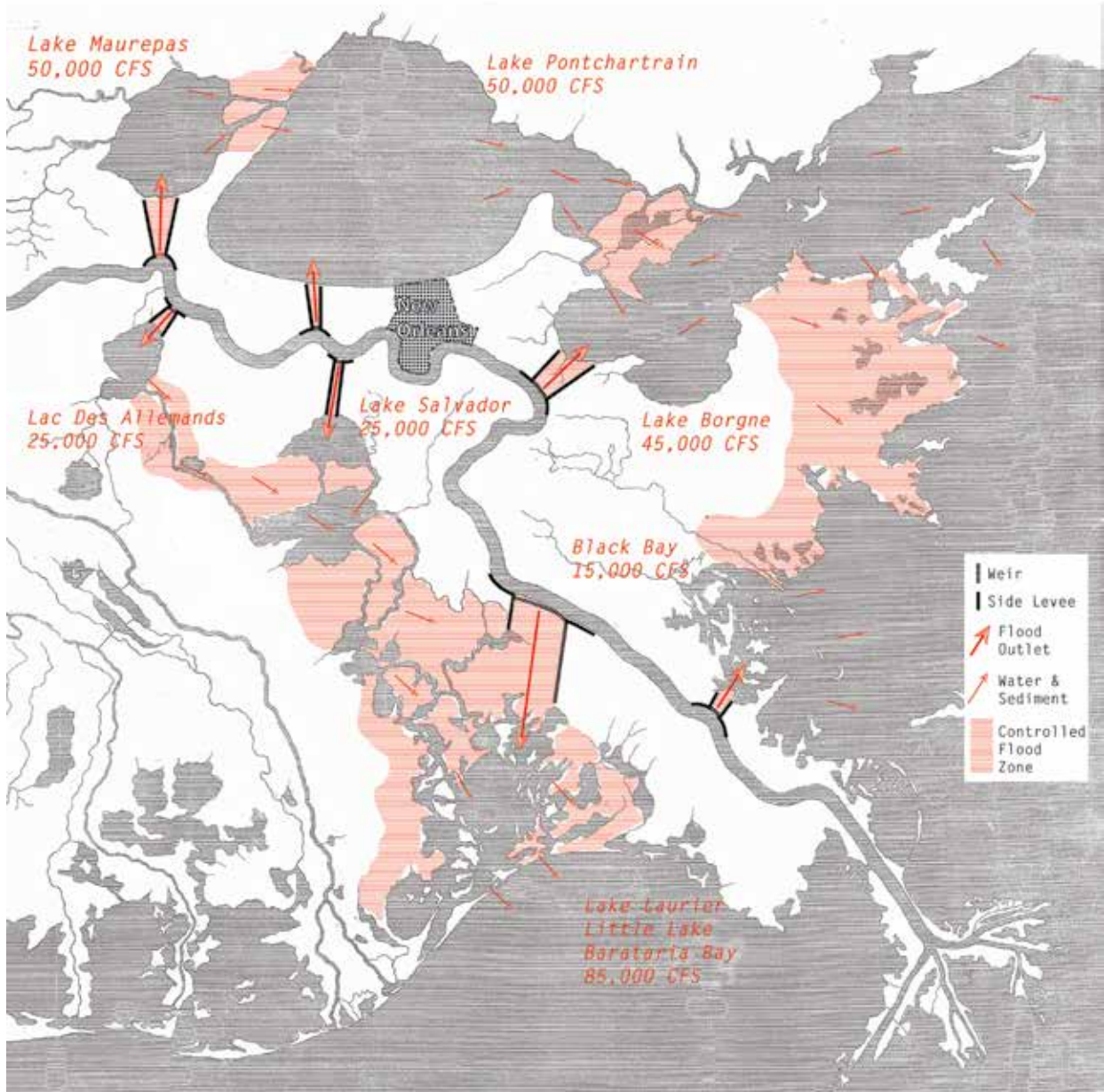

9a: Richard L. Hindle, "A Plan by Linus Brown to Protect Low-lying Riparian Lands of Louisiana" (2015/2016), referencing Linus Weed Brown, "System of Protecting Riparian Lands from Overflow" (U.S. 488,422). The drawing sites Brown's patent at bends of the Mississippi River to facilitate in the discharge of floodwater to natural lakes and bayous in the delta upstream and downstream of New Orleans. The weirs and side-levees would alleviate rising floodwaters incrementally and allow for the recharge of sediment back into the deltaic landscape during periods of freshet.

(No Model.)

L. W. BROWN.

SYSTEM OF PROTECTING RIPARIAN LANDS FROM OVERFLOW.

No. 488,422.

Patented Dec. 20, 1892.

Fig. 1.

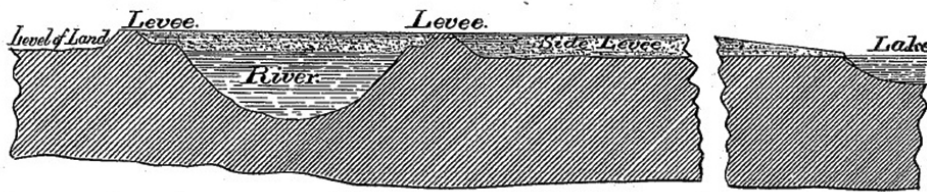
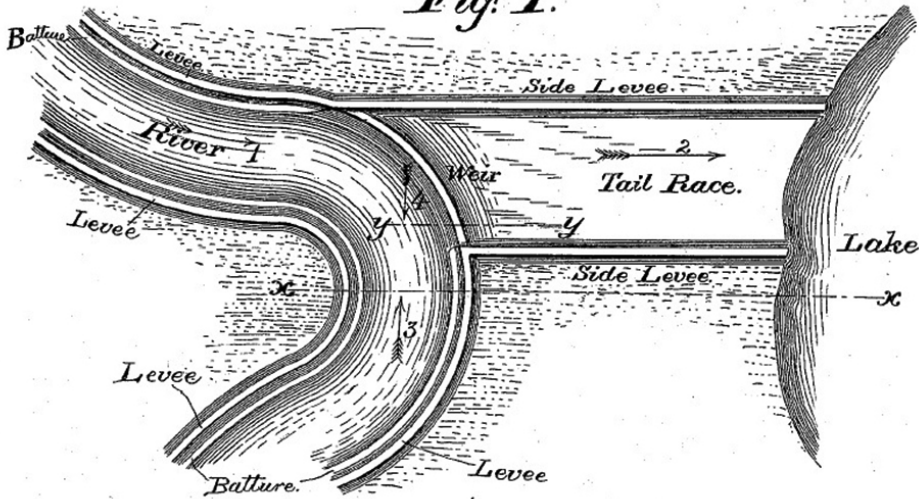

Fig. 2.

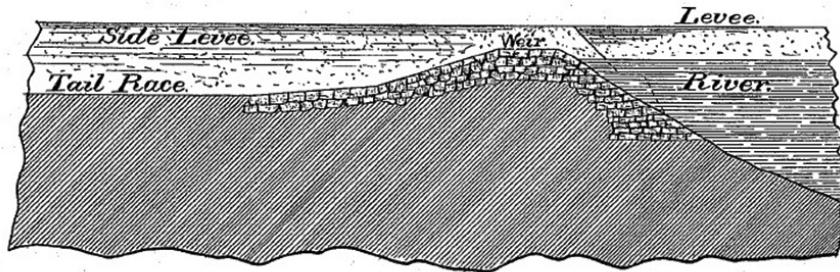

Fig. 3.

Witnesses

Ray C. Bowen.
John Q. Wilson.

Inventor

L. W. Brown,

By Whitman & Wilkinson,
Attorneys.

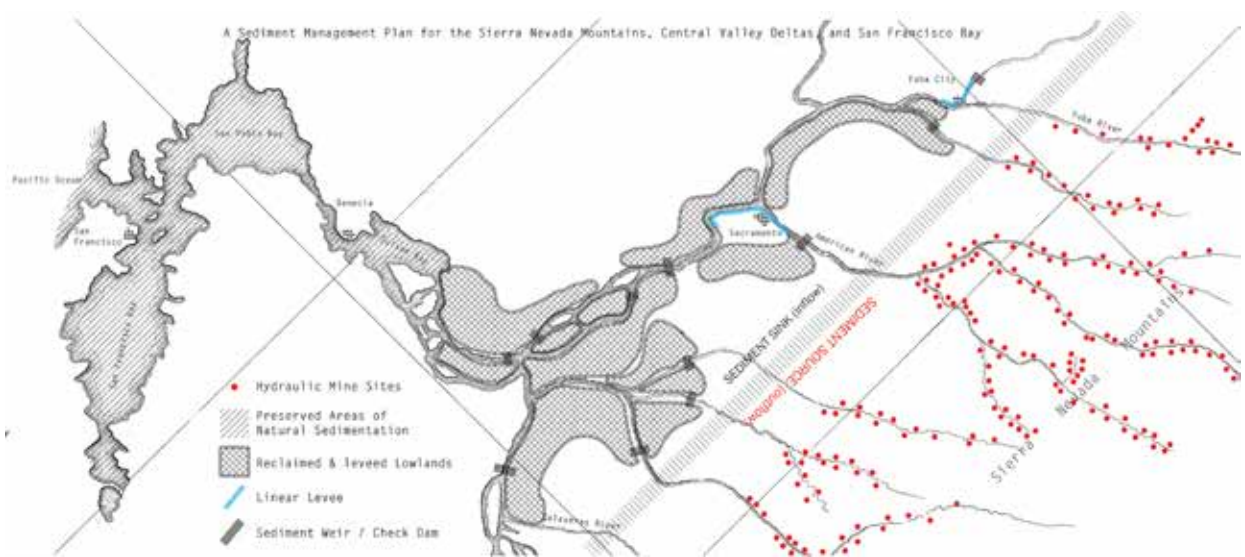

10a: Richard L. Hindle, "A Sediment Management Plan for the Sierra Nevada Mountains, Central Valley Deltas, and San Francisco Bay" (2015/2016), referencing Newton Sewell, "Method of Relieving River Channels of Sediment" (U.S. 235,967). The drawing envisions the potential scale and reach of Newton Sewell's invention, adapting the patent to the conditions of the Sierra Nevada mountains and the Sacramento-San Joaquin Delta during the California Gold Rush, when millions of cubic feet of sediment were displaced by hydraulic mining. The drawing and patent explore methods for the creation of a regional sediment management plan and levee system balancing source/sink sediment budgets for vast river systems.

(No Model.)

N. SEWELL.

Method of Relieving River Channels of Sediment
and Forming Levees.

No. 235,967.

Patented Dec. 28, 1880.

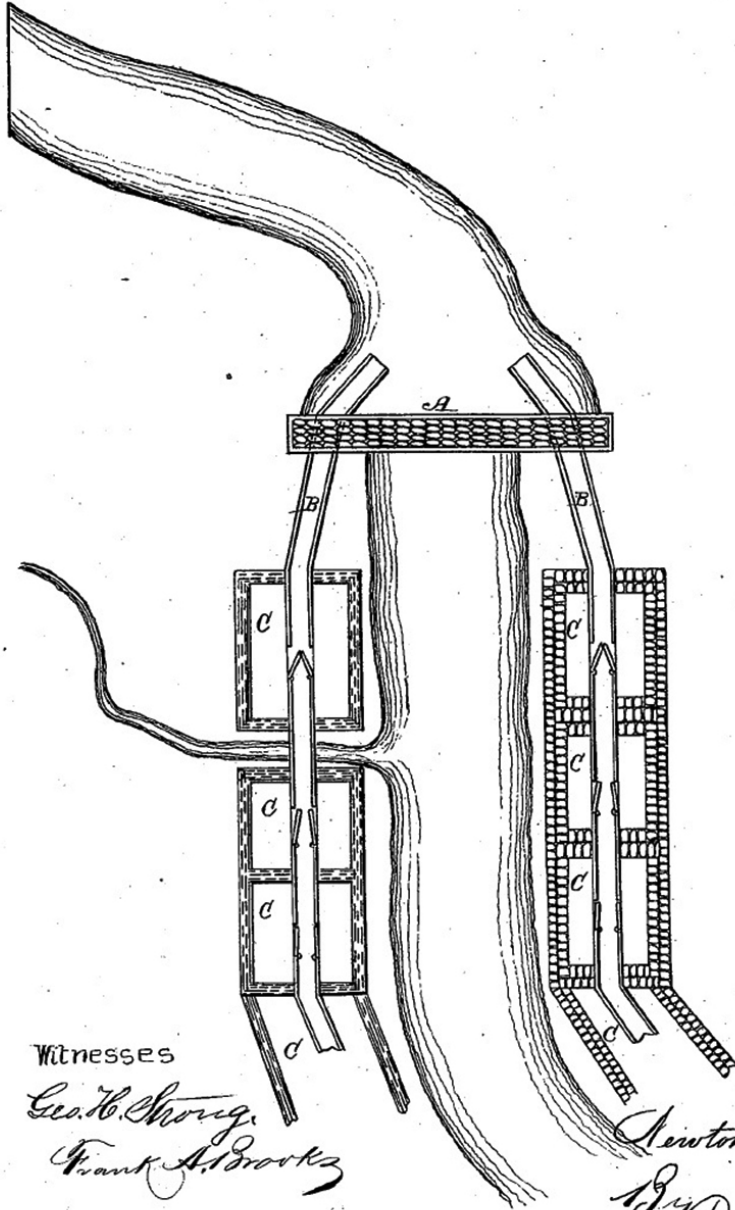

Witnesses

Geo. H. Strong
Frank A. Brooks

Inventor

Newton Sewell
By Dewey & Co.
attys

Review

By Diana Balmori

Given the contingency of landscape, it is shocking to see patents proposing environmental solutions to large geographies—deserts, rivers, coastlines—with no indication of place whatsoever, in either drawing or text. Richard Hindle's account of patents without place offers a rare look—at once revealing and surprising—at the patent process in relation to landscape. Hindle does include examples where location is mentioned in the text or indicated on a map, but one catches on quickly that leaving place out supports a patent's claim to universal applicability.

Even more shocking is just that fact: that patents would deal with large geographies and propose environmental solutions. One imagines a patent to be an object that is a new invention, a machine of some kind, not a large-scale land management strategy formulated in singular circumstances.

For readers not familiar with these patents and their significance for landscape, two further observations warrant consideration. The first is that inventive responses to complex environmental problems with which we are wrestling today began appearing in patents two centuries ago. For example, James Buchanan Eads—the designer and builder of the Eads Bridge in St. Louis, among other important works—offered solutions for the management of the Mississippi River. A most creative engineer, Eads engaged in a long battle with civil engineer Andrew A. Humphreys and the US Army Corps of Engineers (USACE) about the treatment of the Mississippi and proposed solutions more in line with present-day environmental understanding than the levees-only approach that the USACE adopted in winning that battle. Interesting alternatives are described in two of the patents illustrated by Hindle: Eads and James Andrews's "Mattress for Forming Embankment" (U.S. 170,832) and Linus Brown's "System of Protecting Riparian Lands from Overflow" (U.S. 488,422). In the latter of those, Mississippi flood waters are deviated to low-lying terrains and marshes, restoring them with the silt needed to maintain their ecosystems. This is closely related to Eads' proposal of cutoffs in his long battle with Humphreys.

The second observation is that landscape-based patents with a location are more convincing and understandable, at least to an engineer, environmentalist, or landscape architect, than are those without. But to those reading patent applications—not engineers with environmental training, one imagines—location could not have counted for much, at least then. The spread of environmental knowledge and public airing of the problems with past solutions make the task of the patent office a more informed one today.

In the end, a question hangs in the air as to the validity of patents torn from the sites that elicited them. Contingency

and place are central to landscape: “A landscape, like a moment, never happens twice. This lack of fixity is landscape’s asset.”²⁷ With that in mind, Hindle’s “Patent and Place” calls for a new look at patents—both old and new—proposing environmental solutions for large territories.

1 See Frank D. Prager, “Brunelleschi’s Patent,” *Journal of the Patent Office Society* 28 (February 1946): 109–135.

2 *Ibid.*, 109.

3 For a discussion of eidetic images and landscape representation, see James Corner, “Eidetic Operations and New Landscapes,” in *Recovering Landscape: Essays in Contemporary Landscape Architecture*, ed. James Corner (New York, NY: Princeton Architectural Press, 1999): 153–169.

4 See Barry Bergdoll, Peter Christensen, and Ron Broadhurst, *Home Delivery: Fabricating the Modern Dwelling* (New York, NY: Museum of Modern Art, 2008).

5 See Richard L. Hindle, “A Vertical Garden: Origins of the Vegetation-Bearing Architectonic Structure and System (1938),” *Studies in the History of Gardens and Designed Landscapes* 32: 2 (2012): 99–110.

6 See Elijah Huge, “Saving the City,” *Praxis* 10 (2010): 120–127; Richard L. Hindle, “Levees That Might Have Been,” *Places* (May 2015)

7 Kendall S. Dood and National Archives and Records Administration, *Patent Drawings* (Washington, DC: Published for the National Archives and Records Administration by the National Archives Trust Fund Board, 1986). N.B.: Models were only required by law until 1870, though the Patent Office accepted models with applications until 1880.

8 E. L. Corthell, *A History of the Jetties at the Mouth of the Mississippi River* (New York, NY: J. Wiley and Sons, 1880).

9 Thomas Paine, Daniel Edwin Wheeler, and Thomas Clio Rickman, *The Life and Writings of Thomas Paine: Containing a Biography*, vol. 10: *Essays, Letters, Poems* (New York, NY: Vincent Parke and Company, 1908), 238–239

10 See Peter Voorhis, “Improved Method of Obstructing Ice in Rivers and Harbors,” US Patent 63,968, published April 16, 1867; Daniel Spangler, “Submarine Wall,” US Patent 325,127, published August 25, 1885; Christian J. Zeitinger, “Device for Utilizing the Water-Power of Falls,” US Patent 442,000, published December 2, 1890.

11 LeLand M. Williamson, Richard A. Foley, Henry H. Colclazer, Louis N. Megargee, Jay H. Mowbray, and Will. R. Antisdel, *Prominent and Progressive Pennsylvanians of the Nineteenth Century* (Philadelphia, PA: Record Pub. Co., 1898).

12 Lewis M. Haupt, “Dike or Breakwater,” US Patent 380,569, published April 3, 1888.

13 Haupt, “History of the Reaction Breakwater at Aransas Pass, Texas,” *Journal of the Franklin Institute* 165: 2 (1908): 81–97: 82.

14 See American Society of Civil Engineers, *Transactions of the American Society of Civil Engineers* (1905): 435–451

15 Haupt, “Jetty or Breakwater,” US Patent 687,307, published November 26, 1901.

16 United States Congress House Committee on Patents and William Allen Oldfield, *Oldfield Revision and Codification of the Patent Statutes: Hearing Before the Committee on Patents, House of Representatives, on H. R. 23417* (Washington, DC: US Government Printing Office, 1912).

17 See United States Department of Justice, *Annual Report of the Attorney General of the United States* (Washington, DC: Government Printing Office, 1917), 433; *The Washington Law Reporter*, ed. Richard A. Ford (Washington, DC: [The Law Reporter Printing Co./Powell and Ginck], 1909): 79–80; and Illinois Attorney General’s Office, *Biennial Report and Opinions of the Attorney General of the State of Illinois: 1914* (Springfield, IL: State Printers, 1915): 1328

18 See Gregory A. Stobbs, *Business Method Patents* (New York, NY: Aspen Law & Business, 2002).

19 Dionisio Petriella, *Los italianos en la historia del progreso argentino* (Buenos Aires, Argentina: Asociación Dante Alighieri, 1985), 267–268.

20 Oficina de Estadística General, Ministerio de Gobierno, Argentina, *Anuario*

Estadístico de La Provincia de Buenos Aires, ed. Emilio R. Coni (Buenos Aires, Argentina: Imprenta y Fundición de Tipos La República, 1883), 2 vols.

21 Juan Bautista Medici, "System for Formation of Permanent Channels in Navigable Rivers" US Patent 658,795, published October 2, 1900.

22 See American Society of Civil Engineers, *Transactions of the American Society of Civil Engineers* (1910): 470–472.

23 Linus Weed Brown, *Illustrations of Drainage & Harbor Work: City of New Orleans* (New Orleans, LA: T. Fitzwilliam & Company, 1900).

24 Elmer Lawrence Corthell, "The Delta of the Mississippi River," *National Geographic Magazine* 7: 12 (December 1897): 351–354.

25 United States Congress, House Committee on Floods, *The Mississippi River Floods: Hearings Before the Committee on Flood Control, House of Representatives, Sixty-Fourth Congress, First Session, on Floods of the Lower Mississippi River, March 8, 9, 10, 13, 14, and 15, 1916* (Washington, DC: U.S. Government Printing Office, 1916.)

26 Among the exceptions were laws of nature, philosophies, and universal mathematical equations.

27 See Diana Balmori, *A Landscape Manifesto* (New Haven, CT: Yale University Press, 2010), 119 and passim; 225.

Biographies

Richard L. Hindle is an assistant professor of Landscape Architecture and Environmental Planning at the University of California, Berkeley, where he teaches courses in ecological technology and planting design as well as site design studios. Hindle's research focuses on technology in the garden and landscape with an emphasis on material processes, innovation, and patents. His current work explores innovation in landscape-related technologies across a range of scales, from large-scale mappings of riverine and coastal patterns to detailed historical studies on the antecedents of vegetated architectural systems. Hindle's writings have appeared in *Landscape Architecture Magazine*, *Places*, and *Studies in the History of Gardens and Designed Landscapes*. In 2012, he received a Graham Foundation Award for the reconstruction of Stanley White's "Vegetation-Bearing Architectonic Structure and System" (patented 1938). As a consultant and designer, Hindle specializes in the design of advanced horticultural and building systems, from green roofs and facades to large-scale urban landscapes. He has worked with such prominent firms as Michael Van Valkenburgh Associates, Steven Holl Architects, Rios Clementi Hale Studios, and Atelier Jean Nouvel. Hindle holds a B.S. in Horticulture from Cornell University and a MLA from the Rhode Island School of Design.

Diana Balmori is founding principal of Balmori Associates, a landscape and urban design practice recognized worldwide for designing sustainable infrastructures that serve as an interface between landscape and architecture. In 2006, she created BAL/LABs within Balmori Associates to push further the boundaries of architecture, art, and engineering. Balmori is an active voice in national policy and decision-making pertinent to landscape design, architecture, and urban planning. She has served as a member of the US Commission of Fine Arts, a Senior Fellow of Garden and Landscape Studies at Dumbarton Oaks, a board member at the Van Alen Institute, and chair of the Civic Alliance World Trade Center Memorial Committee, among other distinguished appointments. She is the author of numerous books—most recently, *Drawing and Reinventing Landscape* (2014), *Groundwork: Between Landscape and Architecture*, with architect Joel Sanders (2011), and *A Landscape Manifesto* (2010). Writings by and about Balmori have appeared in a wide range of media, including *Dwell*, *Monocle*, *El País*, *PBS*, *Design Observer*, and *Utne Reader*, which named her one of fifty "Visionaries Who Are Changing Your World" (2009). In 2013, she was ranked #3 on *Fast Company's* list of "The 100 Most Creative People in Business" and one of ten "AD Innovators" by *Architectural Digest*. Balmori studied architecture at the University of Tucumán, Argentina, landscape design at Radcliffe College, and urban history at UCLA, where she was awarded a Ph.D. with highest honors. Since 1993, she has been a Critic at Yale University in both the School of Architecture and the School of Forestry and Environmental Studies.