

**UCLA**

**UCLA Electronic Theses and Dissertations**

**Title**

Communication in Home Area Networks

**Permalink**

<https://escholarship.org/uc/item/8mf9x77h>

**Author**

Wang, Yubo

**Publication Date**

2012

Peer reviewed|Thesis/dissertation

UNIVERSITY OF CALIFORNIA

Los Angeles

Communication in Home Area Networks

A thesis submitted in partial satisfaction  
of the requirements for the degree Master of Science  
in Electrical Engineering

by

Yubo Wang

2012



# ABSTRACT OF THE THESIS

Communication in Home Area Networks

by

Yubo Wang

Master of Science in Electrical Engineering

University of California, Los Angeles, 2012

Professor Rajit Gadh, Co-chair

Professor Asad M. Madni, Co-chair

This thesis analyzes different physical layer communications in Home Area Network (HAN) with emphasis on Power Line Communication (PLC). The thesis serves as a general reference and design guideline for deploying HANs through a comprehensive analysis of different protocols, standards and their respective characteristics. Initially, seven HAN design requirements are proposed followed by an evaluation of how well specific techniques fulfill

these requirements. Four most widely used wireless techniques, namely Zigbee, Z-Wave, Low Power Wifi (LP-Wifi) and PLC are studied and compared. In order to better understand PLCs, the challenges associated with it are discussed with a special focus on its noise source. Two most widely used PLC protocols, HomePlug and LonWorks are thoroughly investigated; and three typical HANs, multi-family, commercial building and public parking lot are studied. The differences between these three HANs are carefully analyzed and PLC based HAN designs for these scenarios are presented, being representative for most HAN scenarios.

The thesis of Yubo Wang is approved.

M. C. Frank Chang

Lei He

Rajit Gadh, Committee Co-chair

Asad M. Madni, Committee Co-chair

University of California, Los Angeles

2012

## Table of Contents

List of Acronyms .....	vi
Acknowledgement .....	vii
Chapter 1. Introduction .....	1
Chapter 2. Literature Review .....	4
2.1 Home Area Network .....	4
2.2 Wireless Communication .....	5
2.3 Wired Communication .....	8
2.4 Summary .....	11
Chapter 3. Home Area Network .....	12
3.1 HAN General Knowledge .....	12
3.2 HAN Design Requirements.....	13
3.3 Summary .....	15
Chapter 4. Power Line Communication.....	16
4.1 PLC of Different Bandwidth.....	16
4.2 Current Challenges .....	17
4.3 Noise Source .....	19
4.4 HomePlug.....	20
4.5 LonWorks.....	21
4.6 Summary .....	30
Chapter 5. PLC Based HANs Design .....	32
5.1 PLC Based HAN in Multi-family .....	32
5.2 PLC Based HAN in Commercial Buildings.....	35
5.3 PLC Based HAN for PEV and DR.....	39
5.4 Summary .....	42
Chapter 6. Conclusions and Future Research .....	43
Reference .....	45

## List of Acronyms

<b>Acronyms</b>	<b>Meaning</b>	<b>Acronyms</b>	<b>Meaning</b>
<b>AES</b>	Advanced Encryption Standard	<b>LP-Wifi</b>	Low Power Wifi
<b>AMI</b>	Advanced Metering Infrastructure	<b>MAC</b>	Medium Access Control
<b>AMR</b>	Automatic Meter Reading	<b>MV</b>	Medium Voltage
<b>BB</b>	Broad Band	<b>NB</b>	Narrow Band
<b>CRC</b>	Cyclic Redundancy Check	<b>NV</b>	Network Variables
<b>CSMA</b>	Carrier Sense Multiple Access	<b>NSI</b>	Network Services Interface
<b>DRLC</b>	Demand Response Load Control	<b>NSS</b>	Network Services Server
<b>DSP</b>	Digital Signal Processing	<b>OLE</b>	Object Linking and Embedding
<b>EVSE</b>	Electrical Vehicle Supply Equipment	<b>OSI</b>	Open Systems Interconnection
<b>GP</b>	Green PHY	<b>PEV</b>	Plug-in Electrical Vehicle
<b>HAN</b>	Home Area Network	<b>PLC</b>	Power Line Communication
<b>HDR</b>	High Data Rate	<b>PSD</b>	Power Spectral Density
<b>HEMS</b>	Home Energy Management System	<b>SEP</b>	Smart Energy Profile
<b>HV</b>	High Voltage	<b>SNR</b>	Signal to Noise Ratio
<b>LAN</b>	Local Area Network	<b>SoC</b>	System on Chip
<b>LDR</b>	Low Data Rate	<b>TDES</b>	Triple Data Encryption Standard
<b>LNS</b>	LonWorks Network Service	<b>UNB</b>	Ultra-Narrow Band
<b>LV</b>	Low Voltage	<b>WPA2</b>	Wifi Protected Access 2



## **Acknowledgement**

This work has been sponsored in part by grant from the LADWP/DOE (fund 20699, Smart Grid Regional Demonstration Project).

I would like to express my deepest gratitude to Prof. Rajit Gadh in Mechanical Engineering and Prof. Asad M. Madni in Electrical Engineering. They both are my advisors. They provided me with the inspiration and motivation during the course of this research as well as valuable advice and guidance. During numerous meetings with them, discussing the progress of the thesis, I learnt a lot about guiding independent research in a productive and effective manner.

I would also like to thank Greg Warta and Gordon Grice from Echelon Corp. They offered a lot of technical support on deploying LonWorks network.

I am also grateful to Prof. Lei He in Electrical Engineering who introduced me to the world of smart grid.

Finally, I am thankful to my lab-mates who provided me valuable feedback during my presentations.

## **Chapter 1. Introduction**

With increasing energy consumption and decreasing fossil fuels, the current energy crisis is not a nation specific problem, but rather a global problem that confronts and threatens all of humanity. In 2008, U.S. President, Barak Obama, endorsed an upgrade of our archaic power grid with a smart grid capable of being more economical while also providing better power management for energy conservation. Since then, the state government has invested over 100 billion USDs in smart grid research and development.

A power grid consists of three basic sections: the utility (power generation and management), power line (power delivery) and user (power consumption). Home Area Network (HAN) is on the user side and it is the key in running smart grid applications such as Demand Response (DR) [1], Plug-in Electrical Vehicle (PEV) [2], distributed energy generation [3] and Home Energy Management System (HEMS) [4]. Since most of the smart grid applications reside in the application layer, they are based upon a robust yet economic physical layer deployment. The physical layer is usually referred to as the communication techniques that are used on a daily basis. Thus, the motivation behind this thesis is to study the emerging trend of HAN, and try to answer three basic but important questions to HAN designers: what are the requirements of HAN; how different specific communication techniques meet these requirements; and how to build a HAN to meet these requirements?

To answer these questions, most widely used wireless techniques are first investigated. Former researchers placed significant emphasis on wireless techniques [5][6][7], analyzing pros and cons of each technology and trying to build a seamless wireless network based HAN. On the other hand, the wired technique, PLC, which has been invented for over a hundred year [8], is

conventionally used in communication between user and utility. In recent years, however, it is gaining much attention and heatedly studied to be deployed in HANs [9][10]. Current PLC research includes channel modeling [11][12], power grid topology as it relates to PLC [13], and PLC applications [14][15] in smart grid applications. This thesis focuses on the application of PLCs in smart grid.

It will provide a better understanding of the role that PLC can play in a HAN by understanding the typical applications of PLC so far. Further, it is critical to understand the problems that facing PLC in order to develop robust design. Unlike wireless communications, PLC is subject to strong background noise that is not subject to certain probability distributions. Hence, having a detailed study of the noise source, its frequency bandwidth and the methods to eliminate the noise is of great importance. Last but not least, market side and existing successful PLC products should not be neglected in order to accomplish an insightful study. A market based case study is carried out with the results of estimated cost for each PLC based HAN.

The contribution of this thesis is three-fold. First, this thesis serves as a detailed and comprehensive technical reference for communication in HANs. It provides the basis for further study of HANs during the PhD dissertation. Second, by providing a comparative analysis of different communication techniques in HANs from an economic, characteristic and protocols standpoint, it serves as a valuable design reference. Finally, this thesis presents three PLC design cases in HANs, namely, multi-family, commercial building and public parking lot respectively. There are significant differences among these three from physical deployment to application. A thorough study of these three deployments will provide an insight into the problems encountered in most PLC based HAN design scenarios.

The remaining of the thesis is organized as follows: Chapter 2 provides a detailed literature review of different techniques used in HANs, namely Zigbee, Z-Wave, LP-Wifi and PLC. Chapter 3 provides an analysis and summary of seven design requirements of HANs; the four mentioned technologies are compared based on how well they meet these 7 requirements. Chapter 4 provides an analysis of PLC techniques. Current challenge facing PLC is first proposed, followed by a comprehensive study of HomePlug and LonWorks. In Chapter 5, HANs design studies are conducted on multi-family dwelling, commercial building and public parking lot. Finally, conclusions are drawn in Chapter 6.

## Chapter 2. Literature Review

This chapter provides a review of the existing work in the field of HAN. The following sections discuss the current status of HANs, and the wired and wireless techniques widely used in HANs.

### 2.1 Home Area Network

Home Area Network (HAN) has been a heatedly studied topic over recent years. When referring to HAN, it usually implies the physical layer of a home-based network, which serves as a basis for upper layer smart grid applications, such as Demand Response and Load Control (DRLC), Home Energy Management System (HEMS), Advanced Metering Infrastructure (AMI), etc. [16][17].

There are four main techniques most widely used in HANs, namely, Zigbee, Wifi/Low Power Wifi (LP-Wifi), Z-Wave and PLC. With the exception of PLC, the other techniques are wireless techniques. The key parameters of the four techniques are detailed and compared in Table 2.1 [18][19].

Table 2.1 Comparison of Different Communication in HAN

	<b>Zigbee</b>	<b>Z-Wave</b>	<b>LP-WiFi</b>	<b>PLC</b>
<b>Operating Frequency(Hz)</b>	900-928M, 2.4G	908M/860M	2.4G	2-100M
<b>Data Rate(bps)</b>	20-250K	9.6-40K	1-11M	0.256-200M
<b>Range(m)</b>	10-100	10-100	10-1000	10-10,000
<b>Battery Life</b>	Years	Years	Years	NA

<b>Power Consumption</b>	3.3uW-63mW	~5mw	4uW-56mW	~0.825mW
<b>Security</b>	128bit-AES	TDES	WPA2, TLS/SSL	NA

### 2.2 Wireless Communication

The three wireless techniques widely used in today’s HANs, Zigbee, Z-Wave and Wifi. Fig. 2.1 lists the most widely used chips and their respective manufacturers for each technique.

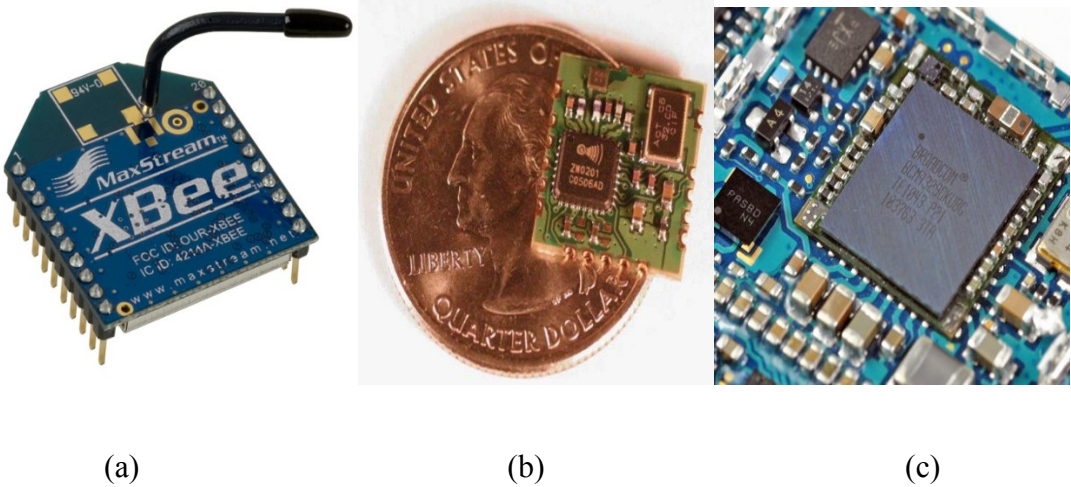

Fig.2.1 Most Widely adopted wireless chips by different manufacturers: (a) Zigbee chips manufactured by XBee (b) Z-Wave chips manufactured by Zesys Corp (c) LP-Wifi chip manufactured by Broadcom

Zigbee is a low power, low data rate protocol that has been widely accepted for smart grid applications; however, it is blamed for its lack of IP support [20]. While the price of the Zigbee device is relatively cheap due to its maturity, the additional gateway that needs to be installed in order to connect it to an IP based network increases the overall price. Recently, Zigbee Alliance

and HomePlug Alliance are working towards the Smart Energy Profile (SEP) 2.0 protocol to make Zigbee an IP support protocol [21]. Zigbee is targeted at transmitting data at 250kbps in the physical layer. From the author's experience, however, it has never achieved more than 25 kbps in application layer transmission. One drawback of a Zigbee device is inter-channel interference. Although there are 255 channels that can be used in an XBee device, two different transmitters can transmit signal in a same channel with the same modulation mechanism, usually causing interference on the receiving end.

Z-Wave is very similar to Zigbee, which forms mesh network. However, Z-Wave is more application specific (only used in smart grid so far), has lower data rate and lower price compared to Zigbee [4][7]. Furthermore, unlike Zigbee devices, which use 16 bits to store network topology, Z-wave uses only 8 bits, which results in a much smaller network size compared to a Zigbee network. The encryption of Z-wave uses Triple Data Encryption Standard (TDES). It is generally considered to be less reliable than Zigbee's 128bit-Advanced Encryption Standard (AES). Therefore, consumers can perceive Zigbee and Z-Wave as targeting different markets: high end and low end respectively [23]. An advantage of Z-Wave is inter-manufacturer interoperability. Currently, Zigbee chips from different companies cannot talk to each other. However, for Z-Wave chips, irrespective of the manufacturer, they are capable of operating with each other.

Wifi adopts the IP protocol, the most widely used network protocol today. The ubiquitous network provides more advanced encryption techniques, Wifi Protected Access 2 (WPA2). However, traditional Wifi is energy hungry [24]; it is always listening to the channel irrespective of the presence of a packet. This is good for short response time but bad for mobile devices with

limited power capability. The comparison of conventional and LP-Wifi is shown in Table 2.2, from which it can be seen that LP-Wifi is consuming much lower energy as compared to the conventional version.

LP-Wifi decreases the power consumption through both hardware and software optimization [25], i.e. System on Chip (SoC) solution in hardware design and adding standby mode in software design. The improvement achieves the same peak data rate at much lower energy consumption, making it a potential candidate for future HAN wireless standard. Fig. 2.2 shows the operation of a LP-Wifi device from the software side. When the LP-Wifi boot up, it sends cold boot signals at one time. Every one minute, the local node sends out linkup trap to the whole network to inform it that this access point is still alive. Every 12 hours, the LP-Wifi sends out a configuration trap signal to the network to see if the network has any update in topology, i.e. new nodes added or existing node deleted. The above mentioned three types of signals are a mandatory requirement in Wifi protocol. The major difference between LP-Wifi and traditional Wifi is in application-specific signals. LP-Wifi does not listen to the channel all the time; rather, it sends/receives application specific application based signal every 2.5 minutes. Between the 2.5 min, LP-Wifi is in standby mode, consuming ultra-low power. The application specific signal does not necessarily have to be in 2.5-min interval; the interval is subject to change according to different application requirements. Therefore, LP-Wifi is able to achieve the same peak data rate as its conventional counterpart but at much lower energy consumption. However, due to the early stage of evolution and acceptance of LP-Wifi, its cost is considerably high. It can be expected that the wide adoption of LP-Wifi in smart grid applications and markets requires more time.



Table 2.2 Comparison of conventional and LP-Wifi From [25]

	Conventional Wifi	LP-Wifi	unit
Standby/Idle	NA	<4	uW
Processor+clock sleep	13	0.2	mW
Data Processing	115	56	mW
Receive sensitivity, 1Mbps	-91	-91	dBm
Time to wake from Standby	NA	10	ms
Time to wake from processor+clock sleep	75	5	ms



Fig. 2.2 LP-Wifi software optimization scheme from [25]

### 2.3 Wired Communication

Wired communication includes Power Line Communication (PLC), telephone line communication and coax communication. This thesis is emphasized on PLC. PCL is a very old

technique dating back to early 1900s [26]. Since then, three major bandwidths have been developed, Ultra Narrow Band (UNB), Narrow Band (NB) and Broad Band (BB) [8]. Their data rate ranges from a few hundred bps in UNB to a few hundred Mbps in BB.

However, in terms of voltage level, the role PLC is playing in smart grid can be roughly divided into three regions: High Voltage (HV) [27], Medium Voltage (MV) [28] and Low Voltage (LV). HV network is the transmission line from the generator to substation while MV is the distribution network between substation and user end. A LV network is often seen as HAN on the user side. As the topic of this thesis is related to HAN, only LV network application of PLC will be reviewed. The following four are the typical roles that PLC is playing in HANs:

(1) ***Automatic Meter Reading (AMR)***. AMR uses UNB-PLC to read smart meter every 15 minutes [29]. As AMR signals are transmitted through LV, MV and HV power grid, the coupling between different level of grid needs further research. Transformers can be modeled as inductance and capacitors, which introduces resonant behavior in the circuits. Besides, capacitors are known for their low pass characteristics [30]. So BB-PLC and NB-PLC cannot bypass a transformer without additional coupling techniques. However UNB-PLC can by-pass the transformer within the low attenuation window.

(2) ***Plug-in Electrical Vehicle (PEV)***. PEV dynamically allocate the charging time of EV to avoid peak hours. In peak hours energy stored in EV's battery becomes an energy source, providing power to the grid. The advantage of using PLC to control PEV is the ubiquitous power line. As EV has to be connected to power line through Electrical Vehicle Supply Equipment (EVSE), by using PLC no additional communication device is needed.

(3) ***Demand Response (DR)***. DR is referred to as managing customer consumption of electricity in response to supply conditions [1]. Similar to the scenario in AMR, BB-PLC is greatly attenuated by-passing a transformer thus not suitable for DR. UNB-PLC is a competitive candidate because UNB signal can by-pass the transformer within low-attenuation window. Also, it is important to adjust the NB-PLC window to those less attenuated “communication windows”.

(4) ***Home Energy Management System (HEMS)***. A HEM is to help consumers better manage their energy usage in home. As the usage of PLC is within a home, both NB-PLC and BB-PLC will operate correctly (no transformers). Applications with PLC such as High Definition TV (HDTV), whole home audio and gaming has been recently introduced [31]. It is widely believed that HEMS is dramatically changing the life style of smart grid adopters.

PLC today is still faced with many problems. It is widely known that PLC cannot couple signal through a transformer or a fuse box. A more severe problem turns out to be the interoperability between different PLC devices. PLC devices are running multiple protocols, including TIA-1113, ITU-T G.hn, IEEE 1901 FFT-OFDM, and IEEE 1901 Wavelet-OFDM [32]. Several major alliance, HomePlug Powerline Alliance (HomePlug), Universal Powerline Association (UPA), High Definition Power Line Communication (HD-PLC) Alliance, and The HomeGrid Forum, are working on PLC [8] based on the above mentioned protocols.

Among the alliance, HomePlug has the biggest market share and recognition in home automation and LonWorks is widely used in industrial and commercial building automation. HomePlug’s protocols are based upon IEEE 1901. There are currently four approved standards in HomePlug: HomePlug Netricity, HomePlug GreenPHY (GP), HomePlug AV and HomePlug AV2 [33][34][35]. Netricity is operating in 10–490 kHz Bandwidth. UNB, GreenPHY and AV both

operate in 1.8-30 MHz bandwidth. The difference between GP and AV is in data coding and data rate, GP can be generally considered as a lower data rate, lower power version of HomePlug AV [33]. AV2 utilize additional 30-80 MHz of bandwidth [34]. It is reported that the utilization of broad band in AV2 has enabled applications such as HDTV and video gaming. In a word Netricity, GP, AV and AV2 are for different data rate applications in HAN.

## **2.4 Summary**

This chapter reviewed some of the important existing work in the HAN area. Wireless techniques such as Zigbee, Z-wave and LP-Wifi were reviewed. As for wired techniques, current trends of PLC and problems it is faced with were summarized.

## **Chapter 3. Home Area Network**

This chapter aims at defining the design requirements of a HAN. There is a more detailed instruction of HAN and power grid structure. Based on that and typical pros and cons reviewed in Chapter 2, this chapter proposes seven HAN design requirements, which designers will find useful.

### **3.1 HAN General Knowledge**

HAN is a residential local area network for communication between digital devices deployed in a home [36].

Fig. 3.1 shows typical functionalities of a HAN and the structure of a power grid. The three basic components of a power grid, which are utility, power line and consumers respectively, are all included in the figure. HAN locates on the user end of the power grid. In the HAN, sensors and transceivers are attached to appliance, using which they communicate with the gateway of the home. HAN serves as the basis for smart grid applications such as DR, PEV and AMI.

As can be seen in the figure, typical communication between utility and home includes internet and PLC. Data and signals such as load control and energy consumption for specific appliance are transmitted through internet, an IP based network. One good side of IP based network is the strong and robust encryption which protects the privacy of specific users. On the other hand, AMI signals are transmitted through PLC. AMI signals are low data rate signals, which make possible to the usage of UNB-PLC to carry them bypass transformers.

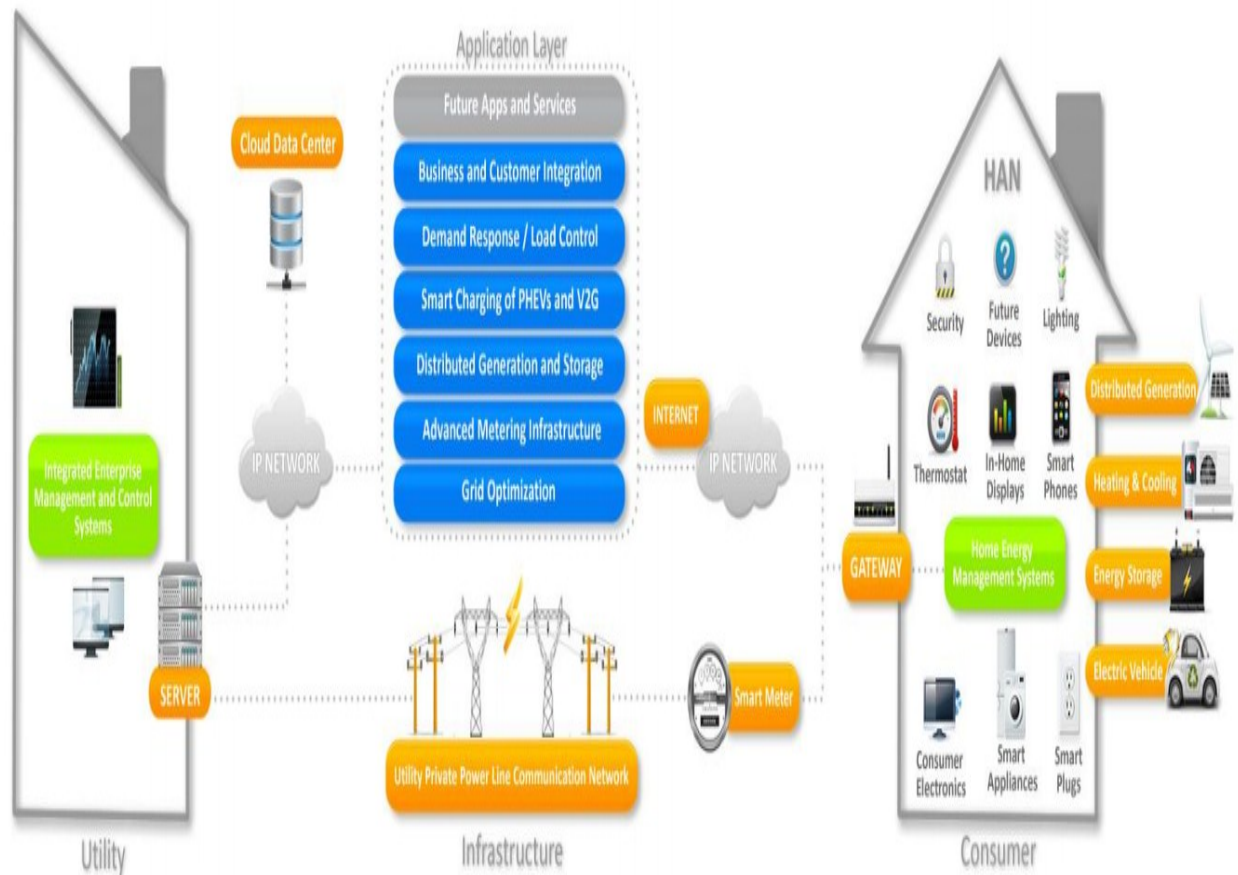

Fig. 3.1 Typical application of HAN (courtesy of Tendril and GTM Research)

### 3.2 HAN Design Requirements

To avoid over-design as well as to fulfill basic functionalities, designers of HAN have to evaluate the following metrics in a HAN design:

(1) **Interoperability.** There are a lot of protocols used in HANs where interoperability has become a major problem [37]. Ensuring that the devices running in a same HAN can talk to each other, operating as a whole system is always a challenge facing designers. Fortunately, some big alliance such as Zigbee and HomePlug are working towards an interoperability protocol [21].

(2) **Data Rate.** The speed of transmitting data is a crucial factor to consider. Different applications are demanding very different data rate, ranging from a few bps to hundreds of Mbps [17][38]. Gaudino et al are even looking at optical solutions to the next generation HAN, targeting at Gbps [6].

(3) **Security.** It is reported and well known that privacy is the major market concern for smart grid applications [39]. A lot of current research is focusing on addressing security issues in smart grid, from wireless to wired techniques [40][41]. This has become an impediment in customer acceptance of smart grid thus deserve further research and special attentions.

(4) **Power Consumption.** The concept of smart grid is proposed partly for saving energy. Hence, in designing HAN as part of the grid, designers need to focus on energy consumption in mind [42]. Low power is always a contradiction to high throughput, but recently new technique such as LP-Wifi has optimized traditional technique [25], making a significant improvement in power consumption while relatively maintaining the same throughput.

(5) **Scalability.** When the network size is growing big, data forwarding problem arises, which always causes packet loss [22]. It is especially true when deploying mesh networks, data forwarding path/mechanism should be chosen carefully [43].

(6) **Cost.** HAN designers cannot neglect the cost of setting up a network; consumers are reluctant to pay a lot up front in order to adopt smart grid applications [44]. Some of the newly emerged techniques with good performance in security, data rate and energy consumption have not been extensively used in HAN because of their high cost [25].

(7) *Ease of use*. When designers are deploying HANs, they should always keep in mind HAN users are not technical gurus as they are. Sometimes, complicated HAN makes a barrier for users to adopt HAN, thus a user-friendly HAN is needed [45].

### **3.3 Summary**

This chapter provided a general introduction of HAN, together with a brief review of the structure of the power grid. Further, seven design considerations: Interoperability, security, power consumption, scalability, cost and ease of use are proposed.



## **Chapter 4. Power Line Communication**

Power Line Communication (PLC) is carrying data through copper line, taking advantage of the existing deployed power line [46]. Power line network is currently perhaps the biggest existing wired network. Therefore, using this existing network can greatly reduce the infrastructure cost. Further, PLC is extremely good at transmitting signals over long distance. In UNB-PLC case, signals are able to be transmitted over 150 km without amplification in between. This chapter describes PLC application from a bandwidth perspective, followed by further analysis of some of the problems facing PLC techniques, especially analyzing the origins of the noise. Additionally, this thesis evaluates two most widely used PLC protocols, HomePlug and LonWorks.

### **4.1 PLC of Different Bandwidth**

From bandwidth point of view, PLC can be classified into three categories, namely, Ultra-Narrow Band (UNB), Narrow Band (NB) and Broad Band (BB). The comparison of three different PLCs is listed in Table 4.1.

UNB-PLC is designed for low data rate communication. Its bandwidth is between 0.3-3k Hz for ultra-low frequency band and 30-300 Hz for super low frequency. A recent example of UNB is AMR in Turtle System, a very low rate (0.001bps) two-way communication [8]. As the bandwidth is extremely low, signals can pass a transformer. AMR is so far the most typical and perhaps the major matured applications of UNB-PLCs.

NB-PLC is operating at a bandwidth of 3-500 kHz. It can be further categorized into Low Data Rate (LDR) and High Data Rate (HDR) sub-bandwidth. The major difference of LDR and HDR is the modulation scheme. LDR uses single carrier modulation while HDR uses multiple-carrier modulation. However, the data rate is still in kbps range. Typical example of NB-PLC includes

LonWorks, ITU-T G.hnem, HomePlug 1.0, etc. NB-PLC is so far the most widely used PLC in HAN.

BB-PLC is recently developed PLCs using 1.8-250 MHz bandwidth for high data rate communication. BB-PLC is designed to fulfill the media stream requirement of a HAN. Typical application includes HomePlug AV and AV2. HomePlug AV2 has a peak data rate of 2 Gbps.

Table 4.1 Comparison of PLC from bandwidth perspective

	<b>UNB-PLC</b>	<b>NB-PLC</b>	<b>BB-PLC</b>
<b>Operating Frequency (Hz)</b>	0.3–3 k /30–300	3-500k	1.8-250M
<b>Data Rate (bps)</b>	~100	LDR:~10K HDR:~100K	~10 - ~100M
<b>Typical Examples</b>	Turtle System	LDR: HomePlug 1.0 HDR: IEEE 1901.2	HomePlug AV, HomePlug AV2

## 4.2 Current Challenges

In spite of the advantages of PLC such as utilizing existing network, long distance, etc., transmission, PLCs face three major challenges.

The first one is high attenuation in communication bandwidth. The attenuation is mainly caused by transformer and distribution of grid (due to parasitic capacitance and distributed resistance from the distribution power line).

A typical transformer equivalent circuit is shown in Fig. 4.1. The model couples the secondary winding of the transformer to primary winding. In the figure, R represents the resistance of

winding.  $X$  is the inductive reactance which accounts for the flux leakage.  $G$ , the conductance, is the core loss due to hysteresis.  $B$  is typically a capacitive susceptance. From the circuit, it is easily seen that the resistance and capacitive susceptance forms a low pass filter. On top of that, the inductive reactance and capacitive susceptance will create resonance. It is the same analysis with the distribution grid. These effects will greatly attenuate the transmitted signal. Even in the low pass window, the response is not flat. Therefore, allocating signal in less attenuated windows, and designing multi-tap equalizer to flatten the response of communication window becomes major challenge.

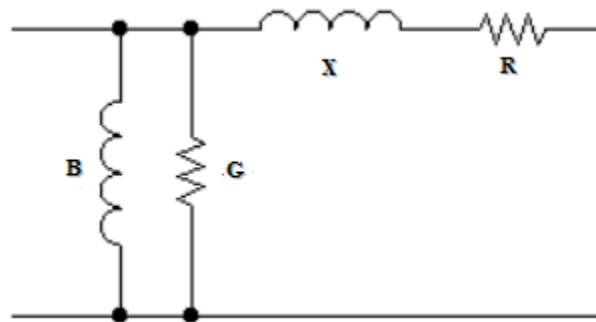

Fig. 4.1 Equivalent circuit model of a transformer

Secondly, the electromagnetic noise in the circuit is significant. The noise comes from a variety of sources, including light dimmers, switch noise and universal series-wound motors [47]. These noises typically have a low bandwidth, which is in the communication bandwidth. Many of these noises are due to human activity, which has a periodicity, and therefore can be predicted. PLC has to address these low bandwidth noises. This problem will be further discussed in section 4.3.

Finally, the PLC has many protocols in the market, including TIA-1113, ITU-T G.hn, IEEE 1901 FFT-OFDM, and IEEE 1901 Wavelet-OFDM [32]. Making these devices working under different protocols inter-operate with each other poses another challenge.

### 4.3 Noise Source

Electronic devices connected to power grid will introduce noise into the power line, thus attenuating the Signal-to-Noise-Ratio (SNR). SNR is defined as follows:

$$SNR = \frac{P_{signal}}{P_{noise}} \quad (4.1)$$

where  $P_{signal}$  and  $P_{noise}$  is the signal power and noise power respectively. The unit of SNR is dB.

According to Shannon's law, the theoretical limit of data rate is determined by:

$$C = B \log_2(1 + SNR) \quad (4.2)$$

where  $C$  is the theoretical capacitance of the channel and  $B$  is the bandwidth.

Noise roughly comes from 3 different sources which are listed below [48]:

- Impulse noise at twice the AC PLC frequency
- Tonal noise in communication band
- High frequency impulse noise

Impulse noise usually comes from the light dimmer. When the lamp is at medium brightness, it injects impulse of tens of volt at the frequency of twice the AC power line. As the mixer down-converts, it introduces image noise into the baseband. Impulse noise can be filtered out through image reject filters.

Usually noise spreads over a wide bandwidth, but tonal noise is referred as the noise that has most of its power in a single bandwidth. Tonal noise can be produced by fans, power line intercoms and switches. These noises are at the frequency of several kHz to hundreds of kHz,

which is in the bandwidth of communication window, making it hard to be fully filtered out. Spread Spectrum and Digital Signal Processing is perhaps the only method to improve the SNR in PLC.

High frequency impulse noise is typically produced by AC motors, such as a vacuum cleaner. The bandwidth of these noises is several Hz to kHz.

Typical Power Spectral Density (PSD) functions of different sources are given in Fig. 4.2.

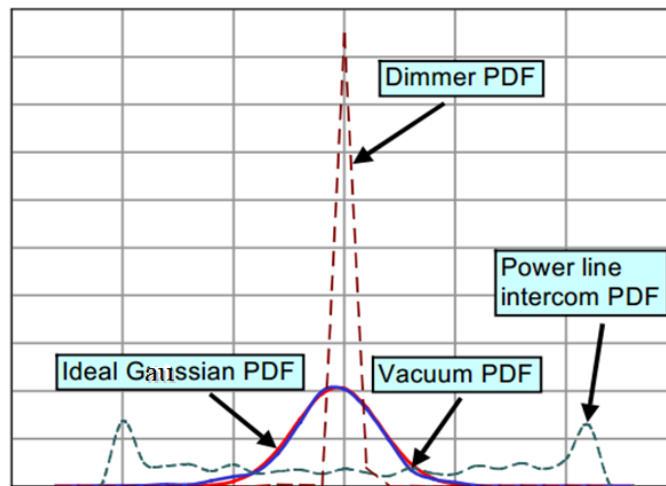

Fig. 4.2 Power Spectral Density of different noise source from [48]

#### 4.4 HomePlug

HomePlug Powerline Alliance is a standard designer for HomePlug certificated products. It has a major market share in home automation, especially in the BB-PLC area. But recently, HomePlug is putting more emphasis on low bandwidth market, developing standard such as Netricity.

Table 4.2 is a comparison of different existing HomePlug certificated standards. As can be seen in the table, from Netricity to AV2, the standards are targeting different bandwidth applications. Netricity is usually used for AMI, for its low bandwidth. Devices do not need high data rate such

as light switches, thermostats, PEV, and smart appliance are using HomePlug GP. Security camera and consumer electronics are using HomePlug AV or AV2 because media stream usually requires more than 100 Mbps data rate.

HomePlug Green PHY (GP), AV and AV2 are developed based on IEEE 1901, which made them compatible with each other. Netricity is developed based on IEEE 1901.2, a standard for low frequency power line devices. HomePlug AV is a matured standard, however, the Netricity and AV2 has just been approved, which is likely to take another two three years to make it widely adopt by the market. HomePlug GP is expected to have mass production in 3Q 2012.

Table 4.2 Comparison of HomePlug certificated standards

	<b>Netricity</b>	<b>Green PHY</b>	<b>AV</b>	<b>AV2</b>
<b>Bandwidth(Hz)</b>	10–490 k	3-30M	3-30M	3-80M
<b>Data Rate (bps)</b>	500k	10M	200M	1G
<b>Standard</b>	IEEE 1901.2	IEEE 1901	IEEE 1901	IEEE 1901

#### 4.5 LonWorks

LonWorks is an open standard developed by Echelon Corporation. It is more than physical layer but rather, Echelon had made LonWorks network a seven-layer protocol. LonWorks is a matured standard, having a much longer history than its competitor HomePlug. The standard is widely used in area like smart buildings, street light controls and home automations. LonWorks is a low data rate NB standard, focusing on energy management rather than media stream applications oriented BB standards such as HomePlug AV/AV2.

### 4.5.1 LonWorks Protocol Overview

The LonWorks protocol is a seven-layer Open Systems Interconnection (OSI) like standard that has been accepted worldwide. They are detailed as follows [49]:

#### (1) Physical layer

Physical layer is the medium over which the signals are transmitted. LonWorks supports Echelon's Free-Topology (FT) and PLC transceivers, as well as third party transceivers.

#### (2) Link layer

Link layer generally provides two functions: Medium Access Control (MAC) algorithm and bit encoding. MAC algorithm is to ensure least possible error rate in a single link. Error typically comes from collision of packets from different transmit station. The algorithm of MAC include p-persistent Carrier Sense Multiple Access (CSMA), non-persistent CSMA and predictive p-persistent.

P-persistent CSMA divide a cycle into equal slots and transmit at the probability of one over the number of slot in each cycle. Basically, the more the number of slots in a given period, the smaller that two transmit stations will transmit signal in a same slot, thus less collision probability. However, it is at the cost of longer delay.

Non-persistent CSMA does not transmit a packet immediately after it is scheduled. It randomizes its access to available slots, avoiding collision in a network of burst traffic.

A predictive p-persistent CSMA utilize the priority slots reserved for specific high priority links.

Fig. 4.3 made a very clear demonstration of how these three MAC algorithms is combined.

Before non-priority slots, there are several priority slots reserved. In non-priority slots, it uses both p-persistent and non-persistent CSMA to access to link.

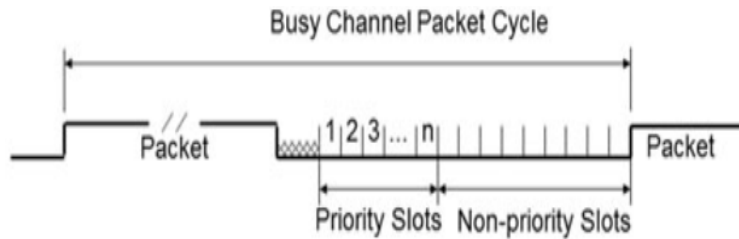

Fig.4.3 CSMA with priority slots (courtesy of Echelon)

Another function of link layer is to perform bit encoding and decoding. It will also add a 16-bit Cyclic Redundancy Check (CRC) to the header for error control.

### (3) Network layer

Network layer solves the problems of how data links are forwarded from source node to destination node. LonWorks uses a hierarchical address to represent each node in the network. The address starts with node's domain, followed by subnets and identification number. Each domain can have up to 255 subnets, and each subnet can have maximum of 127 nodes.

### (4) Transport layer

Transport layer is the middle layer to the upper three layers and lower three layers. It is the layer where packet retransmission and duplicate detection happens. The upper session layer assumes the packet is arriving at a constant rate, though under physical restrictions packet is obviously arriving at different rate. It is the job of transport layer that takes care of resends and packet planning, which make the session layer sees a constant data rate.

### (5) Session layer



In session layer, the request and response is handled. This layer also saves the information of packets position in the transmission process so that if the transmission is cut off, it will be picked up at where it is cut off.

#### (6) Presentation layer

Presentation layer is where encode/decode of the semantics used in application layer. In LonWorks, presentation layer uses Echelon's publisher-subscriber model. Typically, it is where data is encrypted.

#### (7) Application layer

Application layer is where the application is running. In LonWorks, data in this layer is called Network Variables (NV). NV is similar to structure in C programming language. It supports data beyond integer, Boolean and float. The output of NV is feed to the input of NVs given that their data type is compatible. This layer also supports automatic discovery of new nodes in network, which greatly cut down the network installation time. When a node updates its NV, it becomes a publisher in the network. The information is automatically forward to nodes that is subscribing this NV. The detailed data structure is shown in Fig. 4.4.

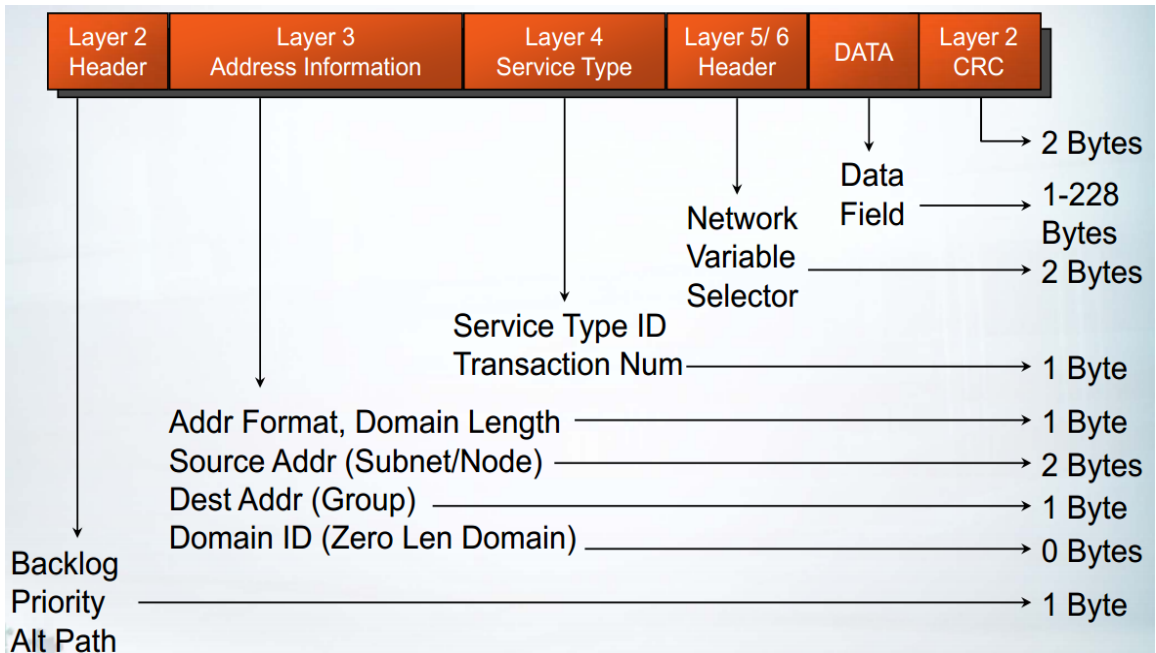

Fig. 4.4 LonWorks Data Structure from [50]

#### 4.5.2 LonWorks Network Structure

Conventional centralized control system consists of one or several central control nodes, a number of routers/substations and thousands of sensor nodes as shown in Fig. 4.5. The central control point uses master-slave bus to communicate with the sensor nodes. A sensor node sends its update to a router/substation before the message is forwarded to central control node. If an action has to be performed, the command comes from the central control point. The relationship of central control to the system is similar to brain is to human beings, irrespective of sensing or actuating, it all goes to or comes from central control.

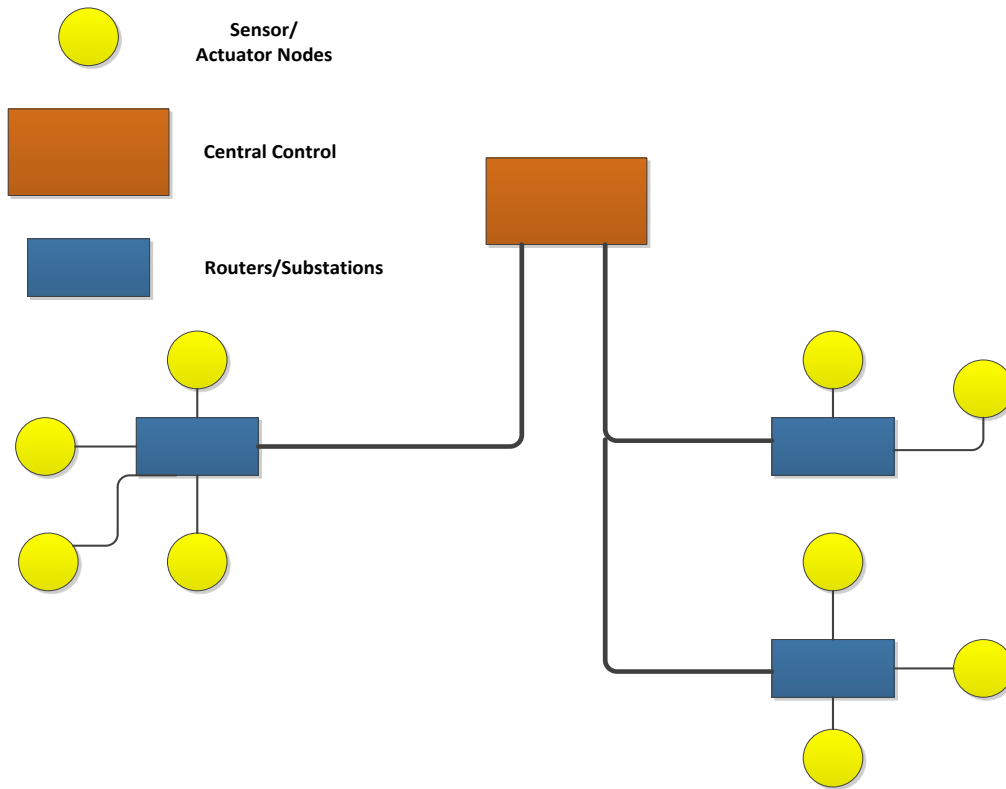

Fig. 4.5 Conventional centralized control system

Conventional centralized control system has been used for hundreds of years, but its robustness is being questioned. The whole system will break down if the central control node is out of order. And part of the system will break down if router/substation is out of order. Echelon proposed a new peer-to-peer distributed control technology. The system is on a publisher-subscriber basis. There is no central control point in this system. But instead, sensor/actuator has to have a stronger micro-controller, which is not too much a demand for today's technology. When a node updates its NV, it publishes the information to whole network. Nodes that are interested in this information will subscribe the source node. This intelligent distributed control system is of course more robust than the conventional one. Even one node dies out, the whole network can still work correctly. An example of the distributed control network is given in Fig. 4.6. Note that

it is possible that this network have some routers. This depends on the application. In cases such commercial buildings, a router is required.

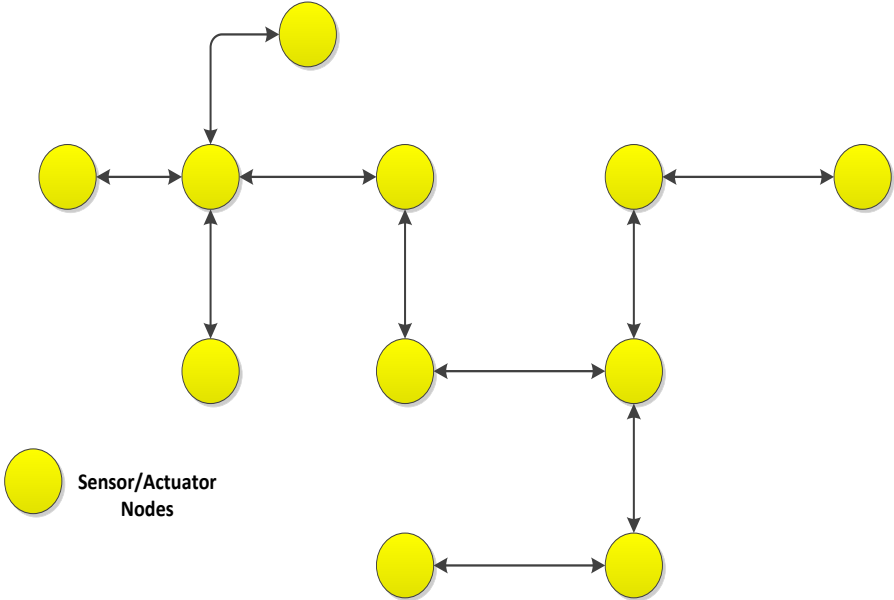

Fig. 4.6 Echelon's distributed control system

### 4.5.3 LonWorks Network Service (LNS)

LonWorks Network Service (LNS) is client-server architecture. It provides users with a foundation for interoperable LonWorks network tools [54]. It brings the client-server architecture and component-based software design into LonWorks control networks [51]. LNS enables component-based software design that is used to install, maintain, and control LonWorks networks. To better understand it, its counterpart in windows software design is Object Linking and Embedding (OLE) from Microsoft.

Echelon provides its users with the industry's first multi-client, multi-server control system. LNS allowed simultaneous enter of the system from multiple system managers and maintenance personnel, which reduced commissioning time and simplified integration.

There are two key components in LNS, namely Network Services Server (NSS) and the Network Services Interface (NSI). NSS is in charge of processing the network service, maintaining the database and directory of the network as well. NSI is a hardware interface that allowed client “talks” with server.

The LNS is a host-independent architecture, supporting servers on multiple systems: Windows 95, Windows NT and the Neuron Chip. Client can be on any platform, including embedded microcontrollers, Windows PCs, and UNIX workstations [51].

Fig. 4.7 shows an example of LNS multi-tool architecture from [52]. As the LonWorks network today is growing larger and larger, Windows PC is often used as the server. The clients come from embedded systems and Windows PC. Note that the SLTA in the figure is referred to the Serial LonTalk Adapter used as the interface for laptop/desktop which has an EIA-232 serial interface. This configuration may be applied to industrial control, building and home automation.

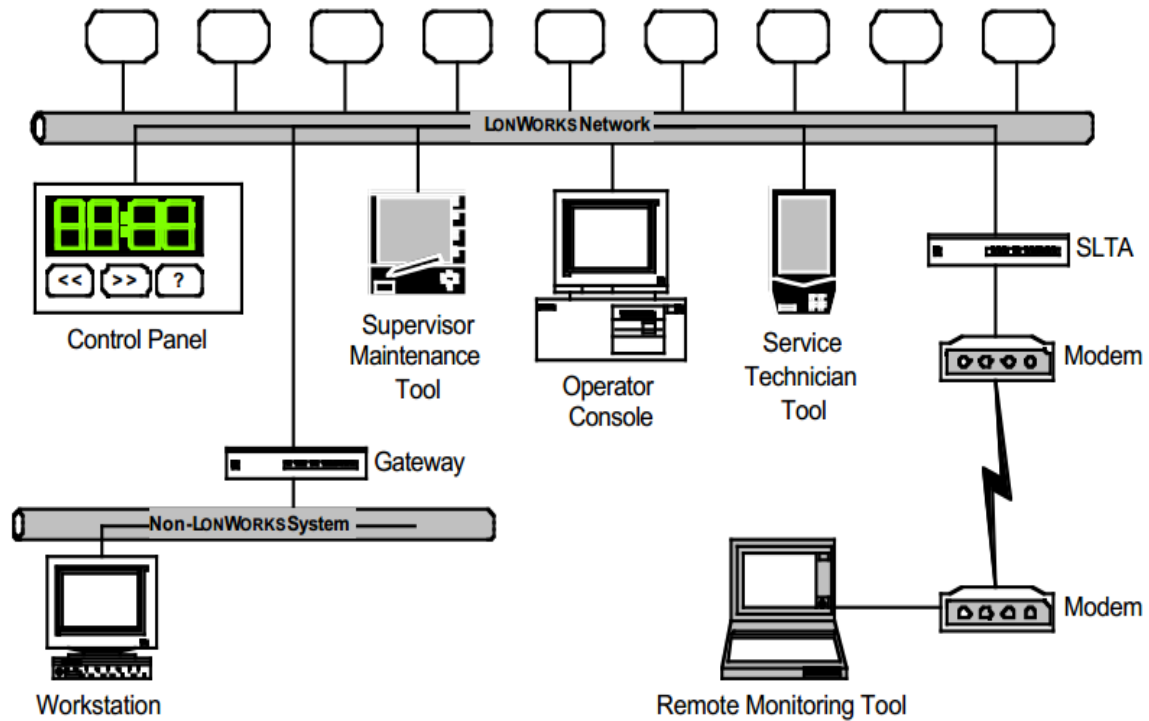

Fig. 4.7 LNS multi-tool architecture (courtesy of Echelon)

#### 4.5.4 LonWorks System Composition

The previous section described the LonWorks system in networked control's perspective, but this section is to study LonWorks from system composition point of view. All LonWorks system consists of three basic components:

- LonWorks compatible devices
- Channel
- Network tools

A LonWorks compatible device consists of a Neuron chip controller, a LonWorks compatible transceiver and often sensors and actuators. All devices need a unique Neuron ID.

The channel is the medium over which data is transmitted. Table 4.3 summarizes channel type from [53]. One thing worth mentioning is LonWorks supports IP network connection. This enables it to be connected to the ubiquitous IP network. However, connection needs additional device. For example, connecting a LonWorks network to IP based network needs additional adaptors.

Table 4.3 Common channel types

<b>Channel Type</b>	<b>Medium</b>	<b>Bit Rate</b>	<b>Compatible Transceivers</b>	<b>Maximum Devices</b>	<b>Maximum Distance</b>
TP/FT-10	Twisted pair, free or bus topology, opt. link power	78kbps	FTT-10, FTT-10A, LPT-10	64-128	500m(Free topology) 2200m(Bus topology)
TP/XF-1250	Twisted pair, bus topology	1.25Mbps	TPT/XF-1250	64	125m
PL-20	Power line	5.4kbps	PLT-20, PLT-21, PLT-22	Environment dependent	Environment dependent
IP-10	LonWorks Over IP	Determined by IP network	Determined by IP network	Determined by IP network	Determined by IP network

Network tools are the software platform that helps network installation, configuration and monitoring. Typically, they come with the development kits and LNS is the core of the software.

#### 4.6 Summary

This chapter provided a very detailed introduction to the technology of PLC, from physical theory to application, and finally two successful industry standards. Three bandwidth PLCs and

their typical applications were introduced, followed by a discussion of the challenges facing PLC. Among all the challenges, a comprehensive analysis of the PLC noise source was addressed. Finally, HomePlug and LonWorks were carefully studied as the paradigm for BB and NB PLC products.



## **Chapter 5. PLC Based HANs Design**

This chapter provides three real design cases of how PLC based HANs could be configured. The first two cases come from multi-family HAN using HomePlug products and commercial buildings using LonWorks products. The multi-family HAN aims at high data rate communication such as media stream while commercial buildings targets at low data rate communication such as energy management. In the end, a PLC based PEV and DR case is studied to show how PLCs based HAN can be used for smart grid applications.

### **5.1 PLC Based HAN in Multi-family**

Multi-family is a specific deployment of HAN in residential buildings. The concept of multi-family indicates duplex, townhouse and apartment. This is a new field in HAN which has not been thoroughly studied. The key questions lie in what device/information can be shared among different dwelling units to make HAN most economic and what device/information must be separated to protect the privacy [5][55]. Not until the above two problems can be understood, multi-family HAN remains a challenge to designers.

Fig. 5.1 shows a design of PLC based HAN in multi-family scenario. As can be seen in the figure, the power of a home comes from a utility distribution vault. It is typically associated with a distribution transformer. This case shows two homes in a same building. It is similar to the deployment of HAN with more than two homes.

This example assumes that home 1 is utilizing a lot of multi-media products such as video gaming and CCTV while home 2 is more interested in home energy management and home automation. But real scenario multi-family unit may contain a mix of these two scenarios. The author uses these two very typical application scenario to demonstrate how to design HANs in

low data rate and high data rate scenarios. But in a mixed case, these two cases are combined, which are compatible with each other.

As HomePlug is especially designed for home automation, it is used as the PLC communication tool. HomePlug product cannot couple single on one phase of power line to another phase. One point worth mentioning in the figure is that as single residential unit typically uses one phase of electric power. Thus, there is no other transformer in a single unit. So HomePlug products can communicate with each other in a single unit without the necessary to add additional routers. This will be very different in a commercial building case in the following section of this thesis.

In Fig. 5.1, Home 1 uses HomePlug AV as the PLC based HAN infrastructure. The reason the author chose HomePlug AV is that it supports high data rate communication up to 200Mbps. All appliance/device are connected together through power line using HomePlug AV adapter. They are routed to a router which connects to ubiquitous Ethernet. Appliances are now accessible to Ethernet without additional routings. Home 2 uses HomePlug GP as the PLC. As home 2's target is home automation and energy control. HomePlug GP, whose data rate is 10Mbps, is suitable for this application.

Notes that there are three points that need to be specially articulated:

- In the case of designing a HAN with both low data rate and high data rate applications, simply combining the studied two-home scenario will work. HomePlug AV and GP are both developed based on IEEE 1902 so that they are compatible to each other
- It is entirely possible that one phase of power line is connected to multiple homes. As HomePlug certificated product supports password, privacy will not become a major threaten.

- In this case, PLC is not shared among different units. The two HANs are independent with each other. But in case of a one phase of power line connecting to multiple homes, routers can be shared.

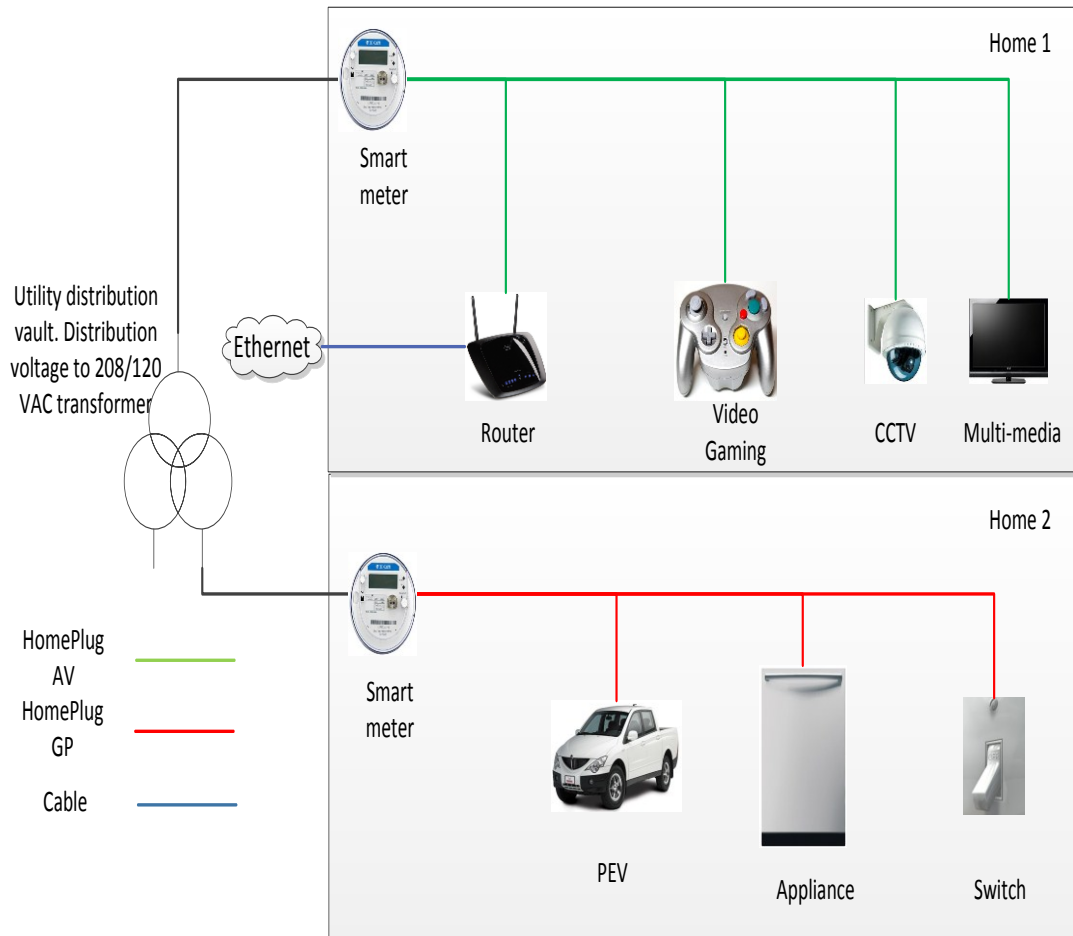

Fig. 5.1 HAN in multi-family

Table 5.1 lists an estimation of a typical multi-family PLC based HAN with 1 router, 3 adapters and 1 wireless extension adapter. It can support 4-8 connections of smart devices/appliance. The cost is expected to be greatly cut down in recent years as HomePlug certified products are more widely used and matured. To make self-designed HomePlug PLC adapter with existing chip could be hard: unlike LonWorks, HomePlug does not support self-design of transmitters.

Table 5.1 Estimated cost of a multi-family HAN

Device	Amount	Unit Cost (USD)
NETGEAR Dual-Band router	1	80
D-Link AV1 500 Mbps adapter	3	50
Linksys AV1 200Mbps wireless extension	1	120
Total Cost		350

## 5.2 PLC Based HAN in Commercial Buildings

Commercial buildings are buildings used for commercial purpose, including office buildings and warehouse. The major difference between commercial building and residential buildings in power line distribution is the following two aspects:

- Residential buildings use phase voltage while commercial buildings use line voltage. This results in a higher voltage (though commercial building can use phase voltage as well) in commercial buildings.
- In commercial buildings, even users use phase voltage, and even users are using power in a same room, they are very likely to use electric power on different phase. On the other hand, people in residential buildings typically use power on the same phase.

Even in a same commercial building, the distribution of power line is not the same over counties to countries. Fig. 5.2 and Fig. 5.3 shows examples of power line deployment in commercial building in America/Japan and Europe/China respectively. As Europe/China uses higher AC voltage than that of America/Japan and given distribution voltages are most of the time similar, power line in commercial buildings in America/Japan needs additional transformer. In these two

figures, it is quite clear that even in the same floor, same room, power can come from different phases. If a seamless commercial building PLC is required, it will result in additional coupling device when transmitting PLC signals in only one phase but all 3-phase can transmit/receive signals. Since PLC signals cannot by-pass transformers without additional coupling devices, commercial buildings in Europe/China typically need less coupling devices compared with its counterpart in America/Japan.

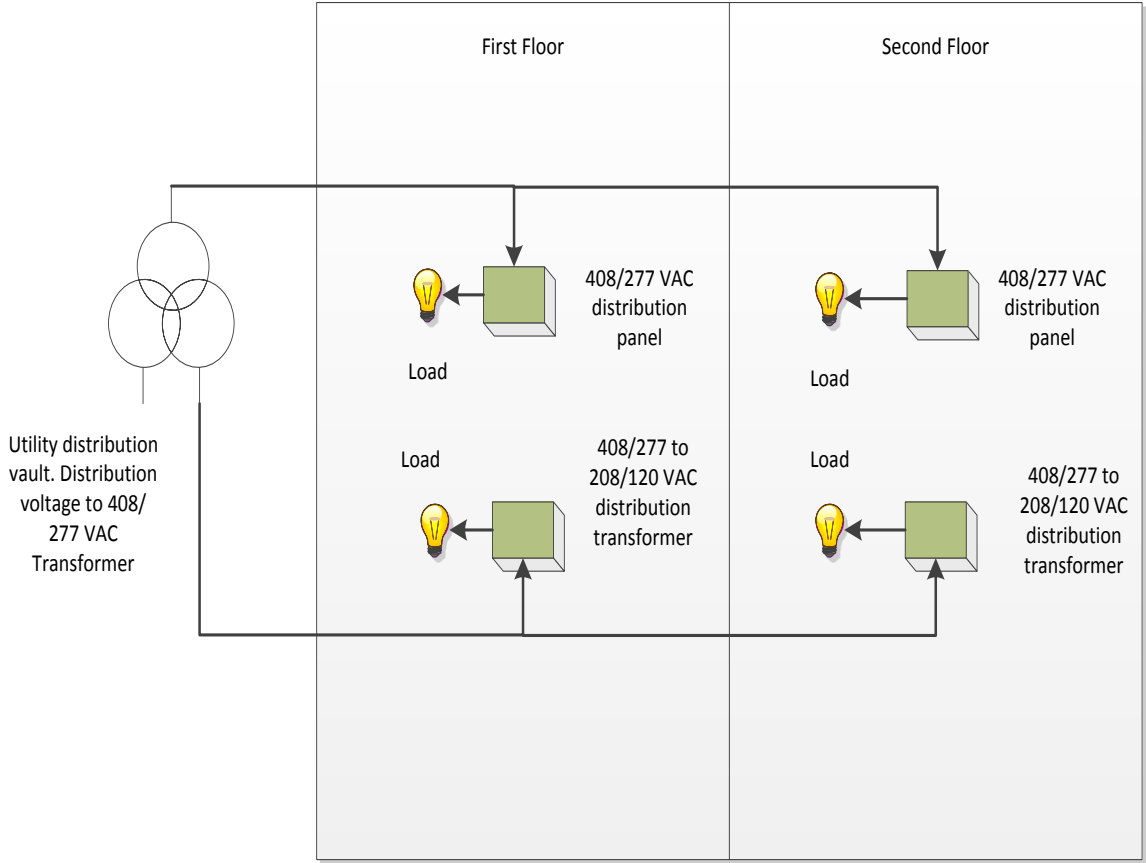

Fig. 5.2 Typical power deployment of commercial buildings in America/Japan

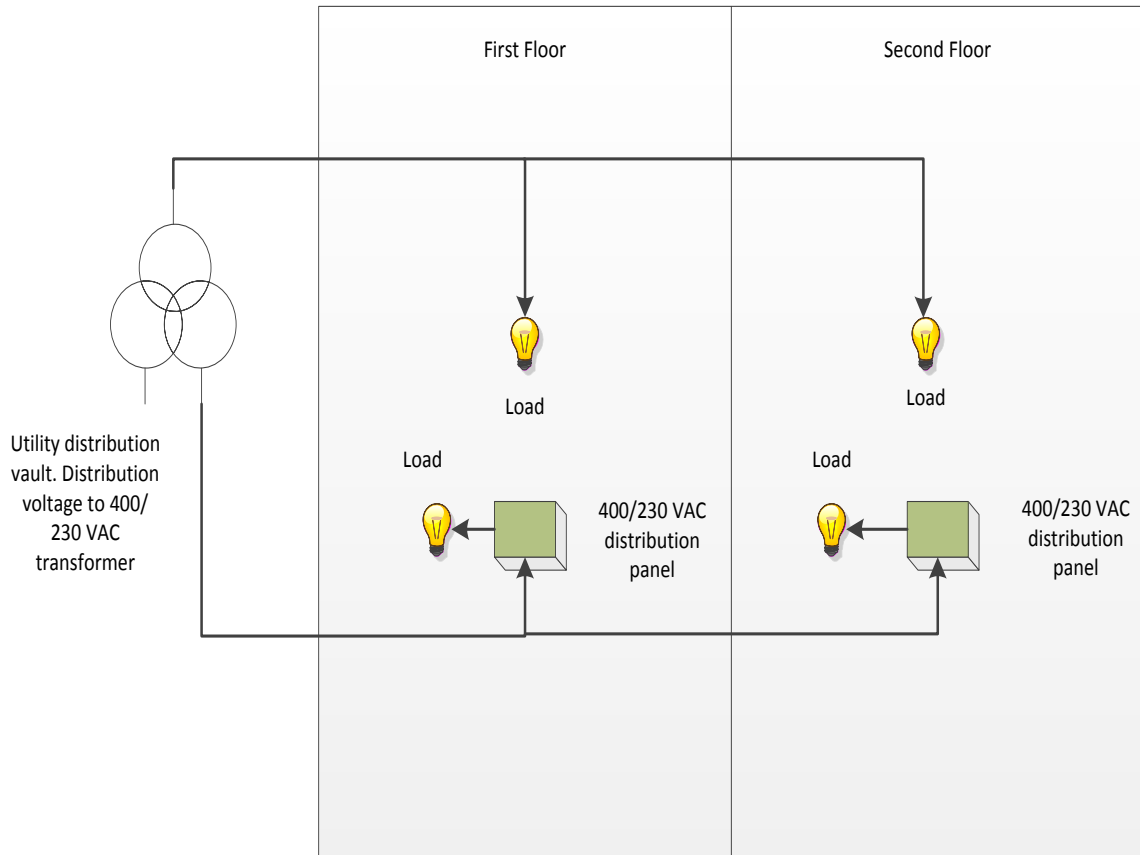

Fig. 5.3 Typical power deployment of commercial buildings in Europe/China

Fig. 5.4 shows a configuration of PLC based HAN in commercial buildings in United States. Since the target of this HAN is building automation and energy management, the data rate is low enough for a successful application of LonWorks network. Quite different from multi-family HAN, additional central monitor and router are needed so that signals in one phase can be coupled to 3 phases. The physical connection of central monitor and router uses twisted line, which forms the backbone of this communication system.

LonWorks provide a mechanism for acknowledgement in communication between two nodes but the information running on the power line is not encrypted. This is reasonable: in commercial buildings, energy management/control does not involve in so much privacy as its counterpart in

multi-family scenario. By the mechanism acknowledgement, the client node utilized keys to check whether the information (control signals) comes from its desired server node, which prevents other node sending fake control signals to client node. If encryption is needed, it must be done manually.

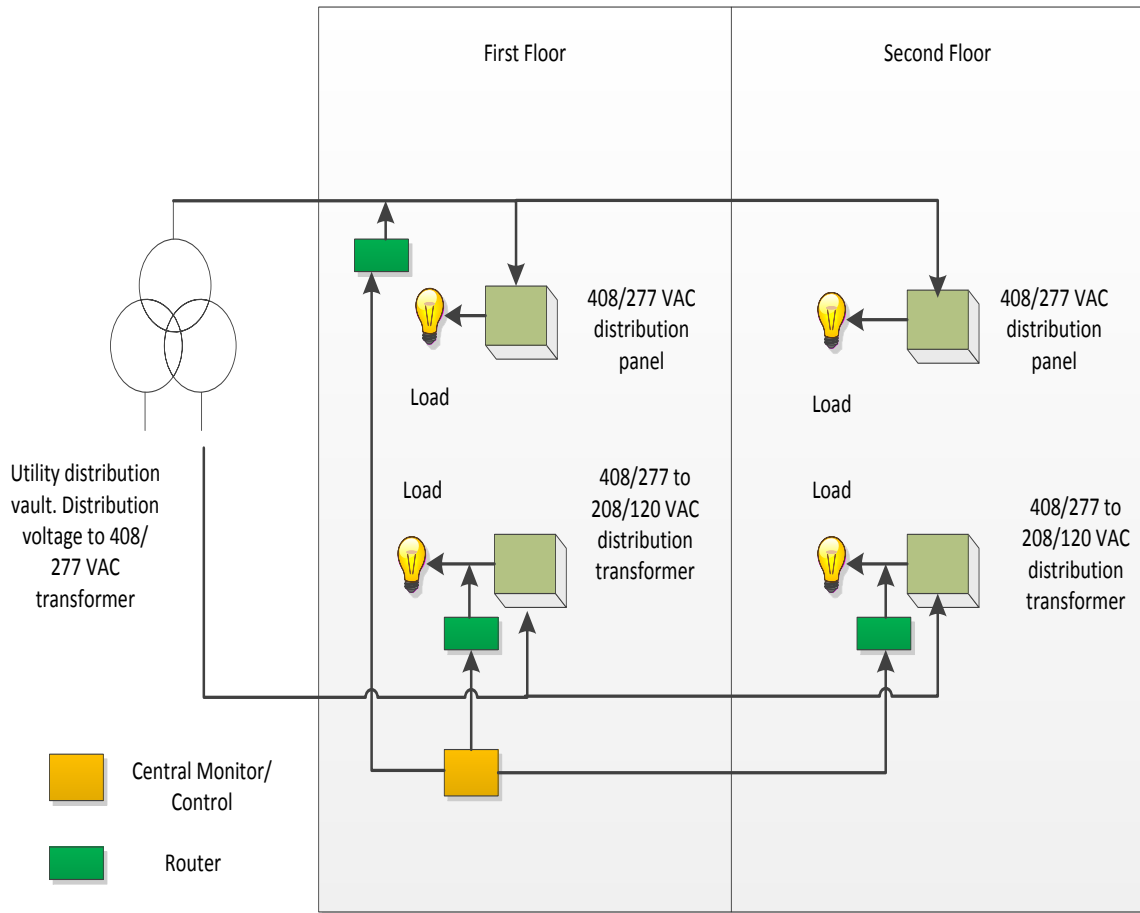

Fig. 5.4 Commercial building deployment of PLC

Table 5.2 shows an estimation of deploying a HAN in commercial building which includes 20 control nodes. The reason for such a high cost is to achieve a 3-phase seamless communication of PLC so that routers and SLTAs are necessary. In this estimation, the average cost deploying one node is around 143 USD. Actually, even the number of Power Line Adapter grows, the need

for router and SLTA will not grow. Thus the cost per node will cut down as the network size grows. Echelon supports design of LonWorks adapters, which will reduce the cost dramatically.

For testing and demo purpose, Echelon’s compact development kit will cost no more than 400 USD. The tool can only achieve PLC communication in single phase.

Table 5.2 Estimated cost of a commercial building HAN

<b>Device</b>	<b>Amount</b>	<b>Unit Cost (USD)</b>
Echelon 2 Channel LonPoint Router	3	350
Echelon Serial LonTalk Adapter (SLTA)	1	400
Echelon LonWorks Adapter	20	50
Total Cost		2450

### 5.3 PLC Based HAN for PEV and DR

Previous sections showed two general PLC based HAN deployment cases in multi-family and commercial building. This section focuses on HAN design to address two smart grid applications, which are PEV and DR.

The studied scenario is a public parking lot with several EVSEs available. The goal is to have full control of the EV so that the two applications can be executed. For PEV application, as the two-way communication can be achieved, users are aware of their charging status and users have full control over the charging process. As for DR, the two-way PLC control also made possible of the utility to have full control over the whole parking lot, so that DR signals can be transmitted to each EV.



Usually, a parking lot is quite big even with several floors. Wireless technique is subject to fading. If we use wireless technology to form a mesh network, a lot of communication nodes have to be deployed, which inevitably increases the cost. So PLC is an ideal candidate for EV parking lot [56].

Fig. 5.5 gives an example of the PLC based HAN deployment in a public parking lot. All EVs are connected to the power supply through a power line. It is entirely possible that EVs are not on a single phase of power supply. The problem is to determine whether we need to add additional routers and central control as in the commercial building case. If they need to be added, it inevitably increases the cost, which is easily doubled.

The author feels that although EVs are on different phase of power supply, their application is entirely different from their counterparts in commercial buildings. In commercial building case, each node in commercial building needs two-way communication. However, in a public parking lot scenario, actually different EVs do not need to talk with each other. The PEV and DR can be achieved by the two-way communication between each EV and a router but maintaining the communication among EVs silent. It is more similar to a master-slave relationship in this application. In Fig. 5.5, each EV is communicating with the router through PLC. Usually routers have more than one port, so that signal from different phase can be connected to a single router.

HomePlug is chosen as the candidate for this PLC network. The reason for not choosing LonWorks is that unlike HomePlug, it does not support direct connect of socket adapter to an IP network. LonWorks has to add a LonWorks to IP network router, which is typically quite expensive. For example, a single iLON 600 Internet EIA-852 LonWorks IP Server/Router costs more than 500 USD. However, for HomePlug network, it simply needs an additional adapter that

connects the PLC to IP network. It can be concluded that for big networks with hundreds of nodes, LonWorks works better. But for small sized network, HomePlug is a better candidate.

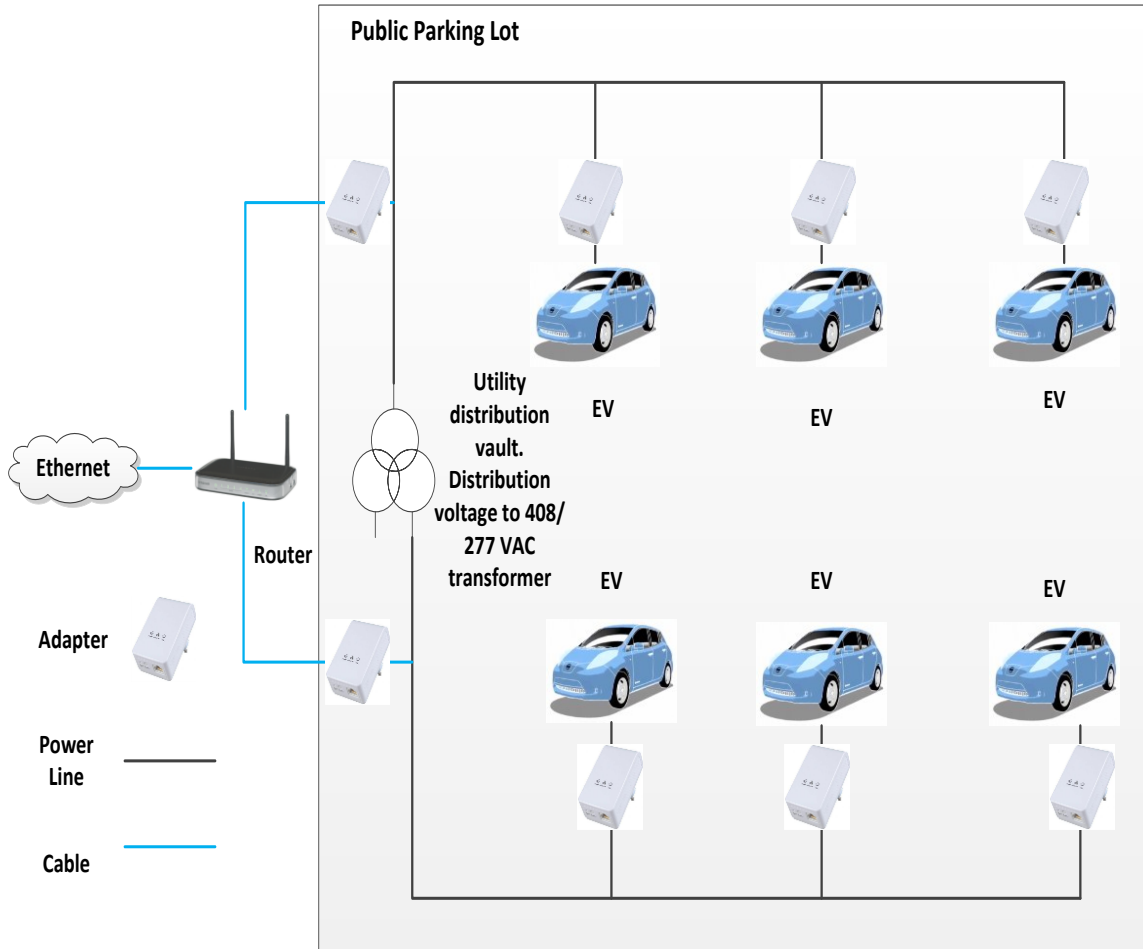

Fig. 5.5 PLC based HAN design in public parking lot

Table 5.3 shows an estimated cost of deploying a 6-node EVSE HAN as shown in Fig. 5.5. Only a common router and 6 HomePlug certified routers are needed. The average cost per node is less than 80 USD.

Table 5.3 Estimated cost of a HAN in public parking lot

<b>Device</b>	<b>Amount</b>	<b>Unit Cost (USD)</b>
NETGEAR Dual-Band router	1	80
D-Link AV1 500 Mbps adapter	8	50
Total Cost		480

#### **5.4 Summary**

This chapter analyzed three kinds of typical HANs, multi-family dwelling, commercial building and public parking lot. Multi-family and commercial building HANs are different in two aspects: first of all, the physical deployment of PLC network is entirely different. In commercial building case, additional central monitor and router are needed to couple one phase signal to three phases. Secondly, the application is different. Multi-family may include high data rate multimedia applications besides low data rate home automation and energy management. In addition to two typical HANs, this chapter also studied an example of how PLC based HANs could be designed in a public parking lot. The study showed that PLC is a good candidate for running smart grid applications such as PEV and DR in a public parking lot at a low cost.

## **Chapter 6. Conclusions and Future Research**

This master's thesis focuses on the communication in HANs. Since HAN is a relatively new concept, the scatter of literature reference has been the obstacle as well as the initiative behind this research.

This thesis starts with a clear definition of what is a HAN, why it plays a fundamental role in smart grid applications. It is followed by briefly reviewing four widely used techniques in HAN physical communication: Zigbee, Z-wave, LP-Wifi and PLC. The key parameters of each technique are collected and compared in order to find out the advantages and disadvantages of each technique.

This thesis proposes seven most important considerations when designing a HAN. And as the thesis develops, it compares how each of the four mentioned techniques meets these requirements. It turns out that none of the four techniques is a perfect candidate for HAN. Thus, HAN calls for a hybrid wired and wireless solution, which of course challenges the interoperability of each the communication protocol.

This study has an emphasis on PLC. Although PLC has existed over 100 years, but recent advance in IC technique has made the old transmission technique a new and promising communication for smart grid. BB-PLC has been developed for media stream oriented HAN communication which can achieve Gbps data rate. To better understand how to improve PLC, the author further analyzed challenges facing PLC, especially the origins of noise. A very detailed discussion of two most widely used PLC protocols, HomePlug and LonWorks is presented. As LonWorks has matured protocol focuses on NB-PLC data transmission, HomePlug

is focusing on BB-PLC transmission. LonWorks is more suitable for large sized network while HomePlug is a good candidate for network of small size.

The thesis has made at least three contributions: firstly, this thesis is a detailed technical reference for communication in HAN; secondly, this thesis proposed design guidelines for HAN. Finally, this thesis carried out typical HAN design in multi-family dwelling, commercial building and a public parking lot, which are representative of HAN designs in most scenarios.

Through months of research, the author not only developed an understanding of the current trend in HAN but also clearly sees each research branches in PLC. It is a formidable task to innovate in channel modeling or power grid topology optimization, both of which have been studied for tens of years and no significant improvements have been achieved in recent years. The appropriate approach seems to be seeking new applications of PLC in smart grid applications: using PLC as a basis to implement new high level algorithms in the application layer and designing application specific software/hardware for HAN.

This work has been sponsored in part by grant from the LADWP/DOE (fund 20699, Smart Grid Regional Demonstration Project).

## Reference

- [1] Huq, M.Z., Islam, S., “Home Area Network technology assessment for demand response in smart grid environment”, Universities Power Engineering Conference (AUPEC), 2010 20th Australasian, pp. 1-6, 2010
- [2] S. Mal, A. Chattopadhyay, A. Yang, R. Gadh, “Electric vehicle smart charging and vehicle-to-grid operation”, International Journal of Parallel, Emergent and Distributed Systems, 2012, 27(3):1-10, 2012
- [3] Capizzi, G., Bonanno, F., Napoli, C., “A wavelet based prediction of wind and solar energy for Long-Term simulation of integrated generation systems”, Power Electronics Electrical Drives Automation and Motion (SPEEDAM), 2010 International Symposium on, pp.586-592, 2010
- [4] Dae-Man Han, Jae-Hyun Lim, “Design and implementation of smart home energy management systems based on zigbee”, Consumer Electronics, IEEE Transactions on, 56(3): 1417–1425, 2010
- [5] Jun Wang, Leung, V.C.M., “Comparisons of Home Area Network Connection Alternatives for Multifamily Dwelling Units”, New Technologies, Mobility and Security (NTMS), 2011 4th IFIP International Conference on, pp. 1-5, 2011
- [6] Gaudino, R., Cardenas, D., Bellec, M., Charbonnier, B., Evanno, N.; Guignard, P.; Meyer, S.; Pizzinat, A.; Mollers, I.; Jager, D. “Perspective in next-generation home networks: Toward optical solutions?”, Communications Magazine, IEEE, 48(2): 39–47, 2011

- [7] Amaro, P., Cortesao, R., Landeck, J., Santos, P, “Implementing an Advanced Meter Reading infrastructure using a Z-Wave compliant Wireless Sensor Network”, *Energetics (IYCE)*, Proceedings of the 2011 3rd International Youth Conference on, pp.1-6, 2011
- [8] Galli, S., Scaglione, A., Zhifang Wang, “For the Grid and Through the Grid: The Role of Power Line Communications in the Smart Grid”, *Proceedings of the IEEE*, 99(6): 998–1027, 2011
- [9] Zhang Xuhui, Zhao Yingjie, Jia Junfeng, Zhang Bin and Liu Ja, “The visualization simulation platform design of low-voltage power line carrier communication system”, *Strategic Technology (IFOST)*, 2011 6th International Forum on, pp.1162–1166, 2011
- [10] Papaleonidopoulos I.C., Capsalis C.N., Karagiannopoulos C.G., Theodorou, N.J., “Statistical analysis and simulation of indoor single-phase low voltage power-line communication channels on the basis of multipath propagation”, *Consumer Electronics, IEEE Transactions on*, 49(1): 89–99, 2003
- [11] Cataliotti, A., Cosentino, V., Di Cara, D., Tine, G., “Simulation and Laboratory Experimental Tests of a Line to Shield Medium-Voltage Power-Line Communication System”, *Power Delivery, IEEE Transactions on*, 26(4): 2829–2836, 2011
- [12] Cataliotti, A., Di Cara, D., Fiorelli, R., Tine, G., “Power-Line Communication in Medium-Voltage System: Simulation Model and Onfield Experimental Tests”, *Power Delivery, IEEE Transactions on*, 27(1): 62-69, 2012

- [13] Z. Wang, A. Scaglione, and R. Thomas, B “Generating statistically correct random topologies for testing smart grid communication and control networks” , IEEE Trans. Smart Grid, 1(1): 28–39, 2010
- [14] Liang Yujie, Liu Peilin, Liu Jing, “A Realities Model Simulation Platform of Wireless Home Area Network in Smart Grid”, Power and Energy Engineering Conference (APPEEC), 2011 Asia-Pacific, pp. 1-4, 2011
- [15] Jianming Liu, Bingzhen Zhao, Jiye Wang; Yi Zhu; Jing Hu, “Application of power line communication in smart power Consumption”, Power Line Communications and Its Applications (ISPLC), 2010 IEEE International Symposium on, pp. 303-307, 2010
- [16] Khan, S.A., Khan, F.A., Shahid, A., Khan, Z.A., “Zigbee Based Reconfigurable Clustered Home Area Network”, Sensor Technologies and Applications, SENSORCOMM '09. Third International Conference on, pp. 32–37, 2009
- [17] Huq, M.Z., Islam, S. “Home Area Network technology assessment for demand response in smart grid environment”, Universities Power Engineering Conference (AUPEC), 2010 20th Australasian, pp. 1-6, 2010
- [18] Pipattanasomporn, M., Kuzlu, M., Rahman, S., “Demand response implementation in a home area network: A conceptual hardware architecture”, Innovative Smart Grid Technologies (ISGT), 2012 IEEE PES, pp. 1-8, 2012
- [19] CA Ardova, C.E.P. JordAAn, Asare-Bediako, B., Vanalme, G. M. A., Kling, W. L.,” Overview and Comparison of Leading Communication Standard Technologies for Smart Home



Area Networks Enabling Energy Management Systems ”, Universities' Power Engineering Conference (UPEC), Proceedings of 2011 46th International, pp. 1-6, 2011

[20] Peizhong Yi, Iwayemi, A., Chi Zhou, “Developing ZigBee Deployment Guideline Under WiFi Interference for Smart Grid Applications”, Smart Grid, IEEE Transactions on, 2(1): 110–120, 2011

[21] ZigBee Alliance. "ZigBee Smart Energy V2.0", 2011

[22] Nassereddine, B., Maach, A., Bennani, S., “The scalability of the hybrid protocol in wireless mesh network 802.11s”, Microwave Symposium (MMS), 2009 Mediterranean, pp.1-7, 2009

[23] Zensys, Inc, “Z-Wave Protocol Overview”, 2007

[24] General Electric Company, “Energy Efficiency Comparisons of Wireless Communication Technology Options for Smart Grid Enabled Devices”

[25] GainSpan Cooperation. "GainSpan Embedded Wi-Fi."

[26] M. Schwartz,B, “History of communications V Carrier-wave telephony over power lines: Early history”, IEEE Communication Magazine, 47(1): 14-18, 2009

[27] B. Renz, “Private Communication”, Amperion, 2010

[28] M. Michel,B, “Moving toward a complete on-line condition monitoring solution”, in Proceeding International Conference and Exhibition on Electricity Distribution (CIRED), pp.12–15, 2003

[29] D. Nordell B, “Communication systems for distribution automation”, Proceeding of IEEE Transmission Distribution Conference, pp. 1-14, 2008

- [30] Electric Railway Improvement Company, “Isolation Transformers and Surge Protection”
- [31] HomePlug Alliance, “How HomePlug Technologies Enhance the Consumer Experience”
- [32] S. Galli, M. Koch, H. Latchman, S. Lee, and V. Oksman, B, “Industrial and international standards on PLC base networking technologies”, Power Line Communication, 2010.
- [33] HomePlug Powerline Alliance Inc, “HomePlug AV White Paper”
- [34] HomePlug Powerline Alliance Inc, “HomePlug AV2 White Paper”
- [35] HomePlug Powerline Alliance Inc, “HomePlug GreenPHY White Paper”
- [36] [http://en.wikipedia.org/wiki/Home\\_network](http://en.wikipedia.org/wiki/Home_network)
- [37] Perumal, T., Ramli, A.R., Chui Yew Leong, “Interoperability framework for smart home systems”, Consumer Electronics, IEEE Transactions on, 57(4): 1607–1611, 2011
- [38] Shengnan Shao, Pipattanasomporn, M., Rahman, S., “Grid Integration of Electric Vehicles and Demand Response With Customer Choice”, Smart Grid, IEEE Transactions on, 3(1): 543–550, 2012
- [39] Vaidya, B., Makrakis, D., Mouftah, H., “Secure remote access to Smart Energy Home area Networks”, Innovative Smart Grid Technologies (ISGT), 2012 IEEE PES, pp. 1-7, 2012
- [40] Tao Zhang, Weimin Lin, Yufei Wang, Song Deng, Congcong Shi, Lu Chen, “The design of information security protection framework to support Smart Grid”, Power System Technology (POWERCON), 2010 International Conference on, pp.1-5, 2010

- [41] Eun-Kyu Lee, Soon Y. Oh, and Mario Gerla, "Physical Layer Security in Wireless Smart Grid", IEEE Communications Magazine, 50(8): 46-52, 2012
- [42] Matsumoto, S., "Echonet: A Home Network Standard", Pervasive Computing, IEEE, 9(3): 88 – 92, 2010
- [43] Zareei, M.; Zarei, A., Budiarto, R., Omar, M.A., "A comparative study of short range wireless sensor network on high density networks", Communications (APCC), 2011 17th Asia-Pacific Conference on, pp.247-252, 2011
- [44] Business Week, "Apartment Nation: Trend to Multi-Family Housing Continues"
- [45] Rana, A.I.; Jennings, B., "Semantic Uplift of Monitoring Data to Select Policies to Manage Home Area Networks", Advanced Information Networking and Applications (AINA), 2012 IEEE 26th International Conference on, pp. 368–375, 2012
- [46] [http://en.wikipedia.org/wiki/Power\\_line\\_communication](http://en.wikipedia.org/wiki/Power_line_communication)
- [47] Echelon Corporation, "Challenges to Reliable PLC"
- [48] Echelon Corporation, "A Power Line Communication Tutorial -Challenges and Technologies"
- [49] Echelon Corporation, "The LonWorks Protocol"
- [50] Echelon Corporation, "Introduction to LONWORKS Technology"
- [51] Echelon Corporation, "LonWorks Network Service (LNS) Architecture Strategic Overview"

[52] Echelon Corporation, “The LonWorks Network Services (LNS) Architecture Technical Overview”

[53] Echelon Corporation, “Introduction to the LonWorks System”

[54] Khurram Hussain Zuberi, “Powerline Carrier (PLC) Communication Systems”, 2003

[55] Erol-Kantarci, M., Mouftah, H.T., “Wireless Sensor Networks for Cost-Efficient Residential Energy Management in the Smart Grid”, Smart Grid, IEEE Transactions on, 2(2): 314-325, 2011

[56] Chang-Un Park, Jae-Jo Lee, Sang-Ki Oh, Jung-Mok Bae, Jong-Kwan Seo, “Study and field test of power line communication for an electric-vehicle charging system”, Power Line Communications and Its Applications (ISPLC), 2012 16th IEEE International Symposium on, pp. 344 – 349, 2012