

Lawrence Berkeley National Laboratory

Recent Work

Title

A Warm Liquid Forward Calorimeter for the SSC - A New Technology with New Challenges

Permalink

<https://escholarship.org/uc/item/8m44v176>

Authors

Hoff, M.

Thur, W.

Wenzel, W.

Publication Date

1991-03-01



Lawrence Berkeley Laboratory

UNIVERSITY OF CALIFORNIA

Engineering Division

Presented at the 3rd Annual International Industrial Symposium on the Super Collider (IISSC), Atlanta, GA, March 13-15, 1991, and to be published in the Proceedings

A Warm Liquid Forward Calorimeter for the SSC — A New Technology with New Challenges

M. Hoff, W. Thur, and W. Wenzel

March 1991

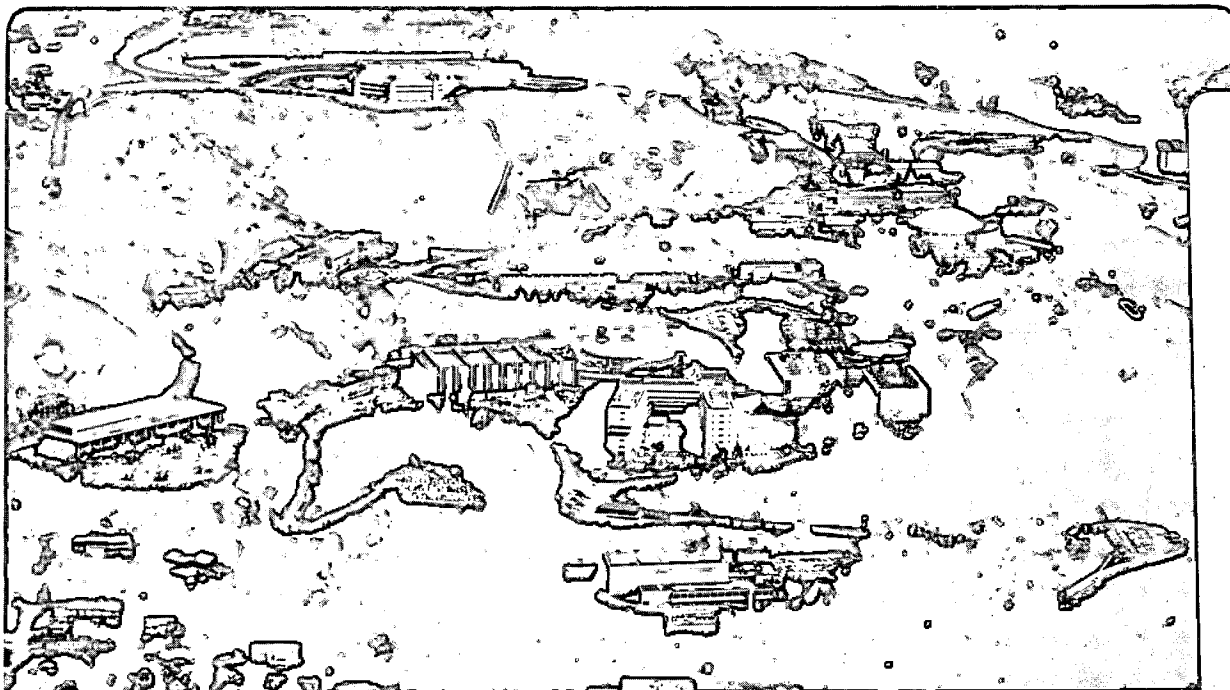

1 LOAN COPY 1
1 Circulates 1
1 for 4 weeks 1
Bldg. 50 Library.
Copy 2

LBL-30402

DISCLAIMER

This document was prepared as an account of work sponsored by the United States Government. Neither the United States Government nor any agency thereof, nor The Regents of the University of California, nor any of their employees, makes any warranty, express or implied, or assumes any legal liability or responsibility for the accuracy, completeness, or usefulness of any information, apparatus, product, or process disclosed, or represents that its use would not infringe privately owned rights. Reference herein to any specific commercial products process, or service by its trade name, trademark, manufacturer, or otherwise, does not necessarily constitute or imply its endorsement, recommendation, or favoring by the United States Government or any agency thereof, or The Regents of the University of California. The views and opinions of authors expressed herein do not necessarily state or reflect those of the United States Government or any agency thereof or The Regents of the University of California and shall not be used for advertising or product endorsement purposes.

Lawrence Berkeley Laboratory is an equal opportunity employer.

DISCLAIMER

This document was prepared as an account of work sponsored by the United States Government. While this document is believed to contain correct information, neither the United States Government nor any agency thereof, nor the Regents of the University of California, nor any of their employees, makes any warranty, express or implied, or assumes any legal responsibility for the accuracy, completeness, or usefulness of any information, apparatus, product, or process disclosed, or represents that its use would not infringe privately owned rights. Reference herein to any specific commercial product, process, or service by its trade name, trademark, manufacturer, or otherwise, does not necessarily constitute or imply its endorsement, recommendation, or favoring by the United States Government or any agency thereof, or the Regents of the University of California. The views and opinions of authors expressed herein do not necessarily state or reflect those of the United States Government or any agency thereof or the Regents of the University of California.

A WARM LIQUID FORWARD CALORIMETER FOR THE SSC

-- A NEW TECHNOLOGY WITH NEW CHALLENGES*

M. Hoff, W. Thur, and W. Wenzel

Lawrence Berkeley Laboratory
University of California
Berkeley, CA 94720

3rd Annual International Industrial Symposium on the Super Collider (IISSC)

Atlanta Hilton Towers, Atlanta, Georgia

March 13-15, 1991

*This work was supported by the Director, Office of Energy Research, Office of High Energy Nuclear Physics, Division of High Energy Physics, Office of the Superconducting Super Collider of the U.S. Department of Energy, under Contract No. DE-ACO3-76SF00098.

A WARM LIQUID FORWARD CALORIMETER FOR THE SSC -- A NEW TECHNOLOGY WITH NEW CHALLENGES*

M. Hoff, W. Thur, and W. Wenzel
Lawrence Berkeley Laboratory
University of California
Berkeley, CA 94720

INTRODUCTION

As part of the WALIC international collaboration, LBL engineers and physicists are building accelerator beamline prototype calorimeters using a room temperature ionizing liquid. If successful, this technology will be an immediate contender for the Forward Calorimeter of the Solenoidal Detector Collaboration (SDC), with potential application to complete, full scale SSC calorimeters.

A 10 ton calorimeter using Tetramethylpentane as the ionizing liquid has been designed and built at LBL, and is now operating at Fermilab. In this unit, the TMP and ionization collecting electrodes are contained in stainless steel "boxes" interleaved with lead absorber plates; -thus the TMP is in contact only with the stainless steel container and a few small ceramic insulators. A second generation design, known as the "swimming pool" version, is under construction. A simplified configuration is used, immersing some 3600 lead absorber/electrode plates directly in the ionizing liquid. Challenges lie ahead in terms of liquid contamination (tens of parts per billion), voltage holding, and vacuum pumpout.

THE PHYSICS MOTIVATION

The advantages of conventional liquid ionization calorimetry (using cryogenic liquid argon) are well known. Direct collection of charge leads to a stable, well calibrated and uniform signal response. There is flexibility and ease of segmentation in both depth and surface area, relatively high resistance to radiation, and, with the recent development of the electrostatic transformer, insensitivity to magnetic fields.

A vigorous R&D program pursued world wide in the past few years has shown that some organic liquids at ambient room temperature (so-called "warm liquids") can also make excellent calorimeters. The yield of electrons, taking into account dE/dx , electron lifetime and drift velocity is comparable with that for liquid argon; and the relatively short drift times are an advantage in suppressing signal "pile-up". Warm liquids require neither cryogenic

*This work was supported by the Director, Office of Energy Research, Office of High Energy Nuclear Physics, Division of High Energy Physics, Office of the Superconducting Super Collider of the U.S. Department of Energy, under Contract No. DE-ACO3-76SF00098.

equipment nor thermal insulation; this encourages simplicity, flexibility, and hermeticity. (A highly hermetic calorimeter is one which has a minimum of dead, or inactive volumes due to structural components.) Furthermore, as hydrogenous materials, organic liquids can provide a compensated response - equal sensitivity to hadronic and electromagnetic particles.

Warm-liquid calorimeter technology for the SSC has made considerable progress in the last two years. Although some of this comes from a sharpening of the overall concept of the SDC detector, most springs from a deeper understanding of the capabilities of warm-liquid calorimetry resulting from an aggressive and successful R&D program. The present viability of the warm liquid calorimeter technology is the result of progress in three particular areas of the R&D program:

1. Results in the investigation of handling, liquid purity requirements, and material compatibility issues have indicated that many commercial construction materials and devices can be used in the calorimeter, and have indicated the type of component cleaning procedures that are needed.
2. Work done in developing an accelerator beam scale swimming pool Test Beam Module has resulted in a practical detailed design for the internal absorber/electrode tile assembly and support, high voltage distribution, and signal readout consistent with compatible materials, good hermeticity, and inexpensive assembly. The TBM is scheduled to be ready for testing at Brookhaven National Laboratory in early FY92.
3. Investigation of the electrostatic transformer readout has shown that it can attain the required charge transfer speed if employed in a proper design.

CURRENT STATUS

In November of 1990, the Warm Liquid Calorimetry group at LBL completed a conceptual design study for a full-scale, complete warm liquid calorimeter for the Solenoidal Detector Collaboration. The study portrayed a practical warm liquid SSC calorimeter that would offer superior physics research capabilities by virtue of its great hermeticity, full compensation, fine grain structure, and excellent resolution. It would have adequate speed, signal to noise ratio, and radiation hardness to meet or exceed all of the SDC requirements.

The SDC faced a difficult choice in selecting a single calorimeter technology to be incorporated into the ultimate SDC detector. In the end, a scintillating plate design was chosen, with conventional liquid argon technology as the backup. Despite its promise, warm liquid was not considered to be a well enough established technology for this fast-track, large scale project. Warm liquid was, however, cited as a highly promising technology which might be proven in time for the smaller, separate, high flux SDC forward calorimeter modules.

This is our current focus. We aim to complete successfully our Test Beam Module experiments at Brookhaven, and to compete aggressively to be chosen for the SDC forward calorimeter technology. Looking further ahead, we expect the experience and credibility gained in operating a successful SDC warm liquid forward calorimeter to become a springboard for larger warm liquid calorimeters.

THE TEST BEAM MODULE DESIGN TO BE TESTED AT BROOKHAVEN

Unlike the full scale SSC calorimeter which will analyze particles emanating in all directions from a high energy head-on collision of accelerated particles, the current Test Beam Module is used as a target for a well-directed particle beam. The "shower" of secondary collision particles which results from the beam's penetration of the TBM's absorber plates is essentially a small solid angle picture of what would be seen by a collider calorimeter. We hope to learn a great deal from this TBM, which is about 1/1000th the mass of a full scale SSC calorimeter.

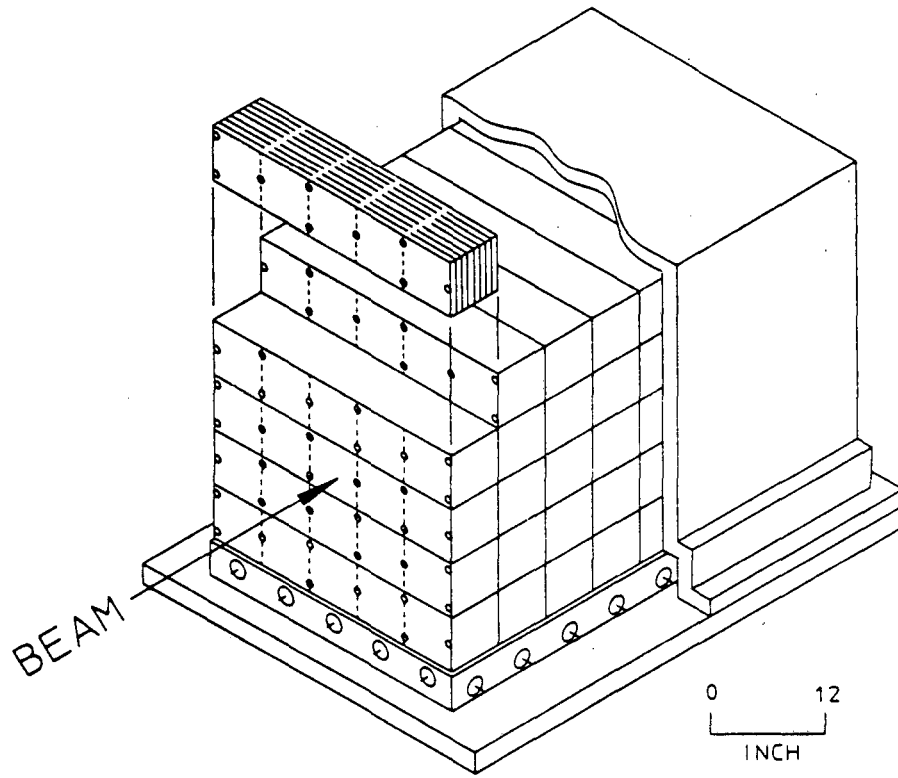

Fig. 1 Swimming Pool Test Beam Module

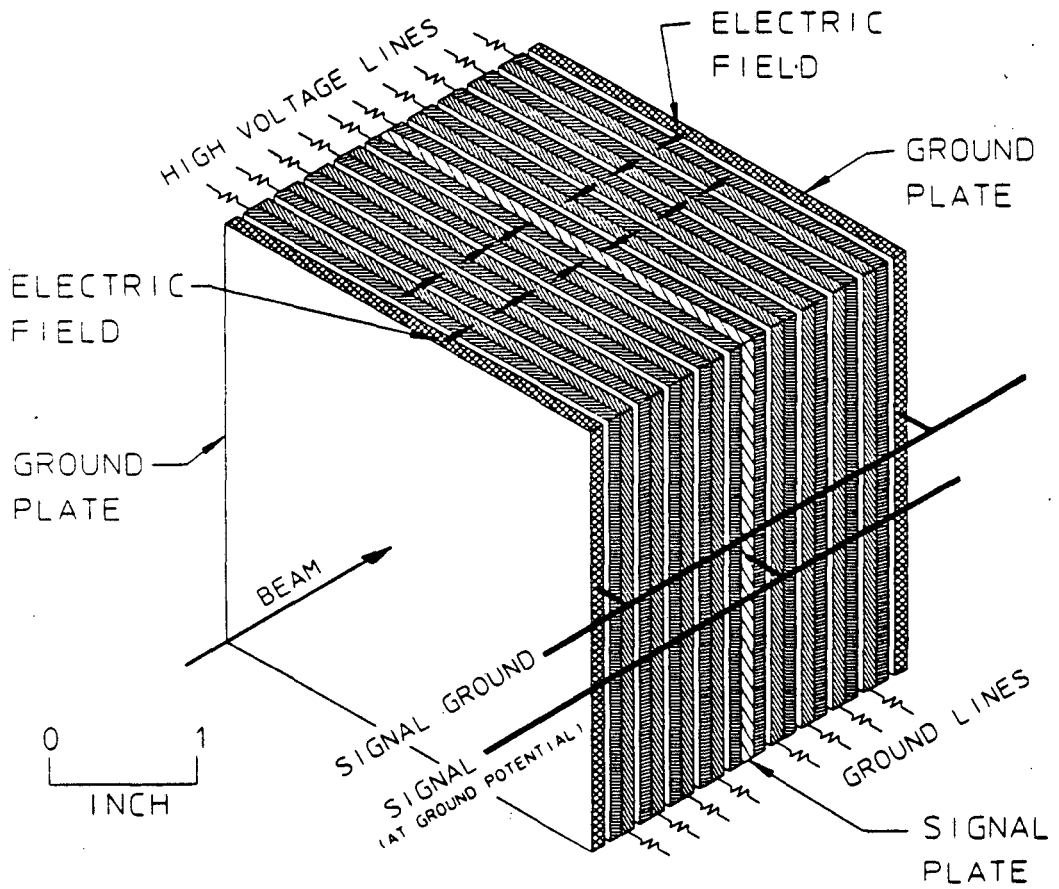

Fig. 2 Electrostatic Transformer Cell

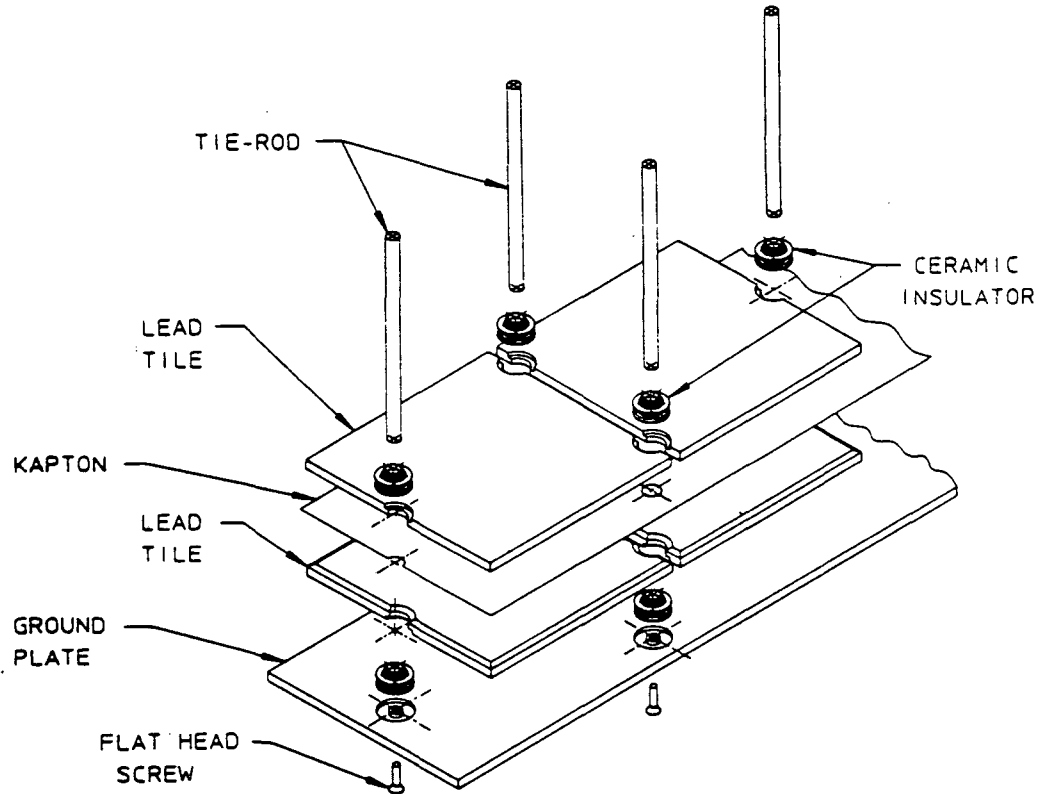

Fig. 3 Internal Construction

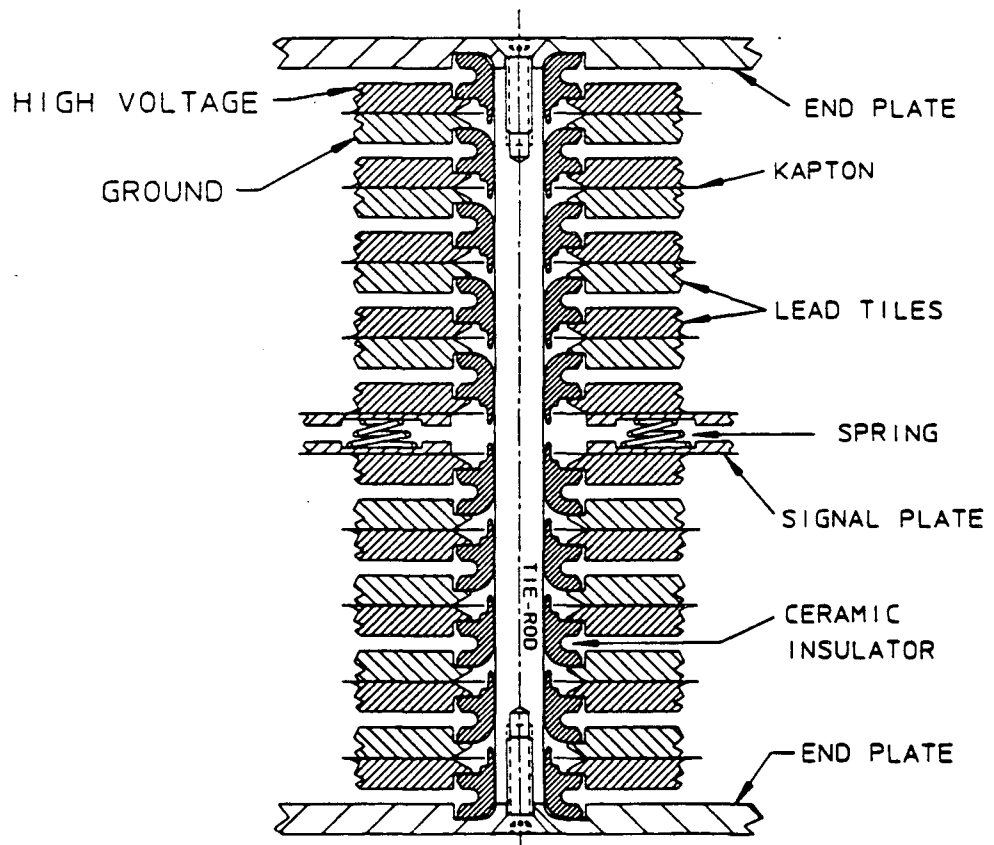

Fig. 4 Cross-section through Active Gaps

THE WARM LIQUID SDC FORWARD CALORIMETER

The conceptual design of a Warm Liquid Forward Calorimeter is a current topic among our group at LBL. We expect that it will share many of the basic construction features used in our Test Beam Module, but it must meet special needs as well. A pair of forward calorimeters will cover the small angle regions very close to the beam pipes on either side of the collision interaction point. At these small angles, the flux of particles to be detected is much more intense than at larger angles. Ideally, the forward calorimeter would have finer spatial resolution and a higher data rate capability than the main calorimeter. It must also withstand much higher levels of damaging radiation over its lifetime. As the furthest physical extension of the SDC detector system, it must accommodate the interface with the SSC accelerator, including the nearby cryogenic quadrupole beam focusing magnets. It must also be retractable or removable in some fashion to allow for access to the massive main calorimeter and muon detectors.

Several designs are being considered. The cone and cylinder geometries which absorb the low angle particles at a "grazing angle" offer significant savings in overall mass, and provide inherent shielding for the surrounding muon detectors. However, there are still open questions about particle "shower" development at these low grazing angles; -questions which will be answered by Monte Carlo simulations. The more conventional "backstop" geometry has normal incidence, but it is more massive, and will require additional steel shielding for the surrounding muon detectors. From the physics point of view, it is also burdened with a discontinuous coverage transition from the main calorimeter end cap. Various hybrid cone/backstop geometries are also being considered. There is an advantage in covering the very high radiation zone at low angles near the beam pipe with a separately maintainable liquid volume, such as a backstop.

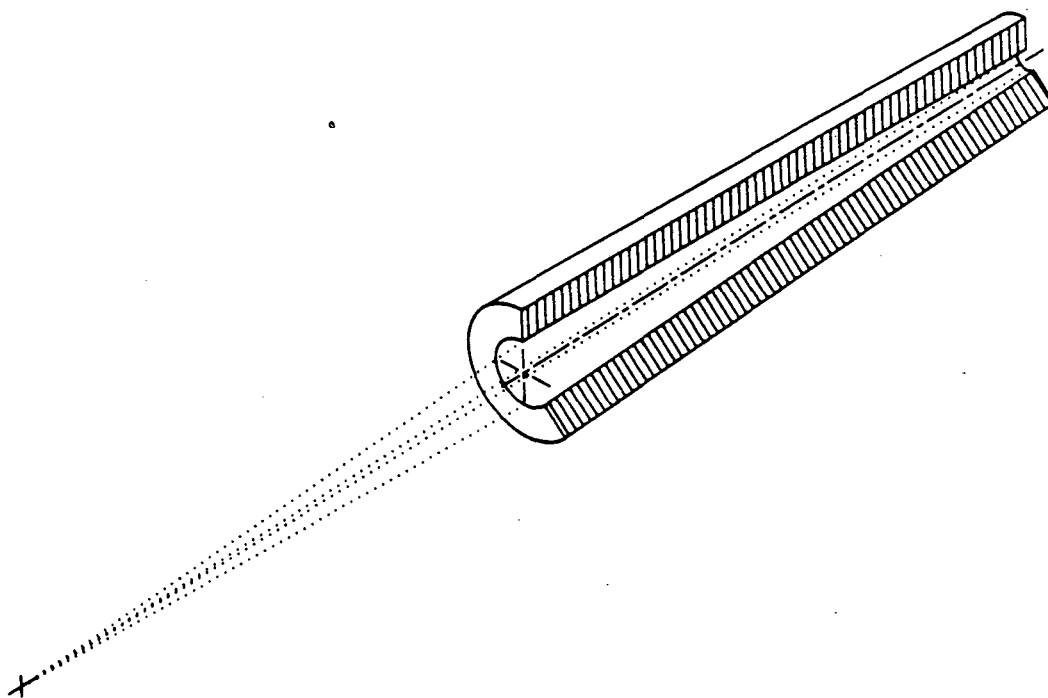

Fig. 5 Cone

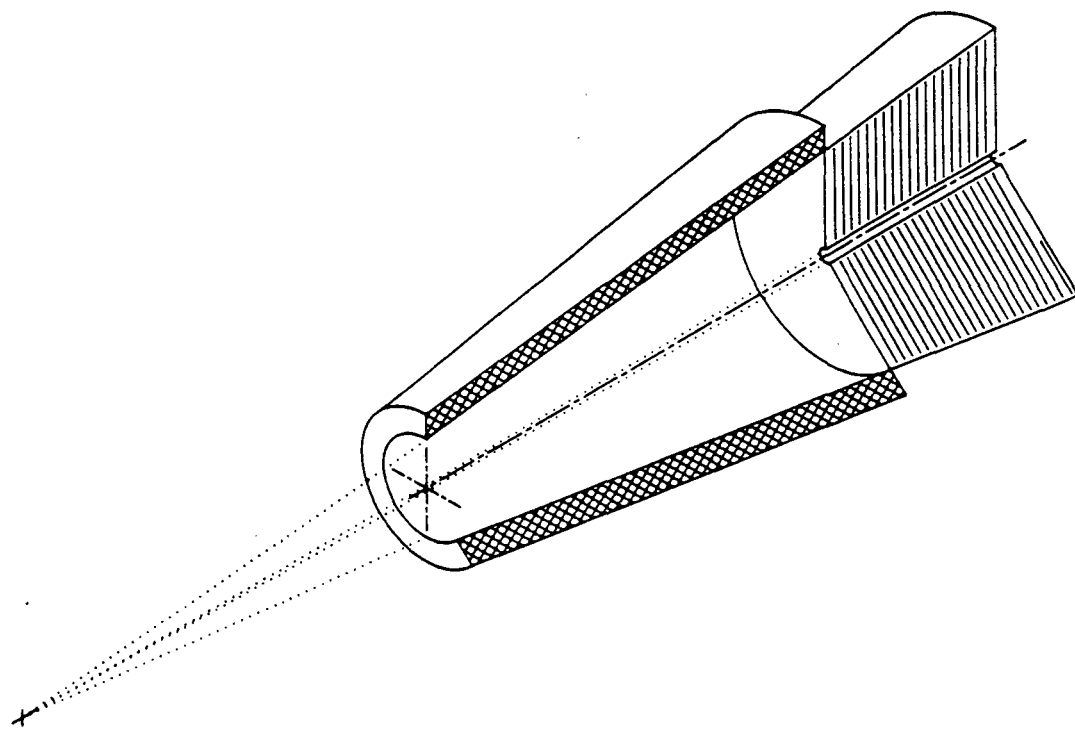

Fig. 6 Backstop with Muon Detector Shield

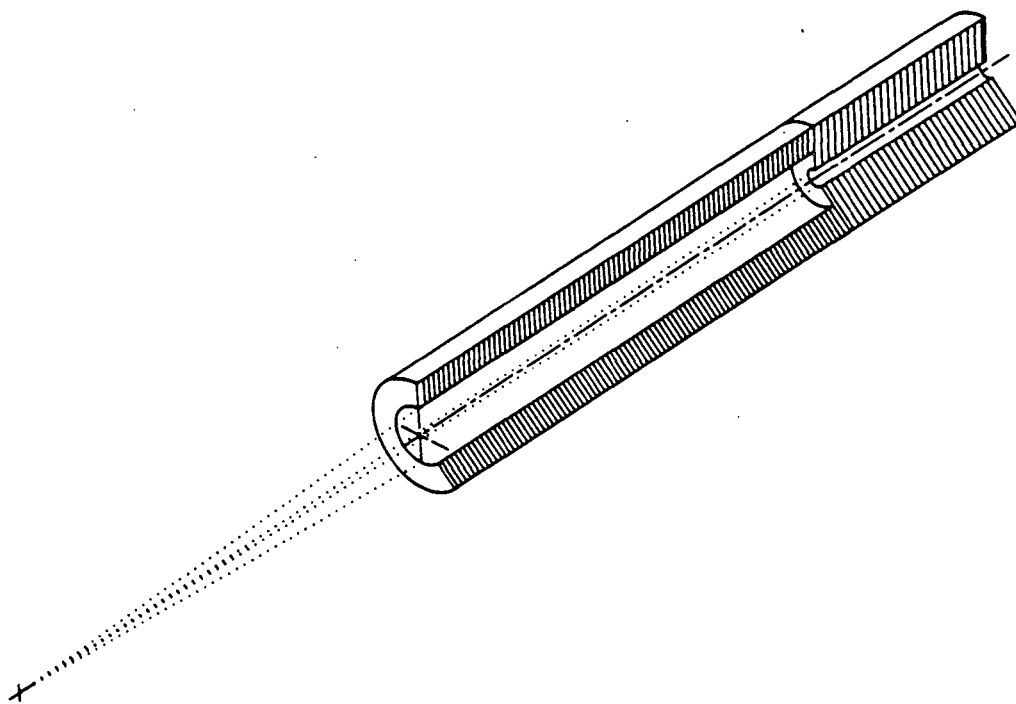

Fig. 7 Hybrid Geometry

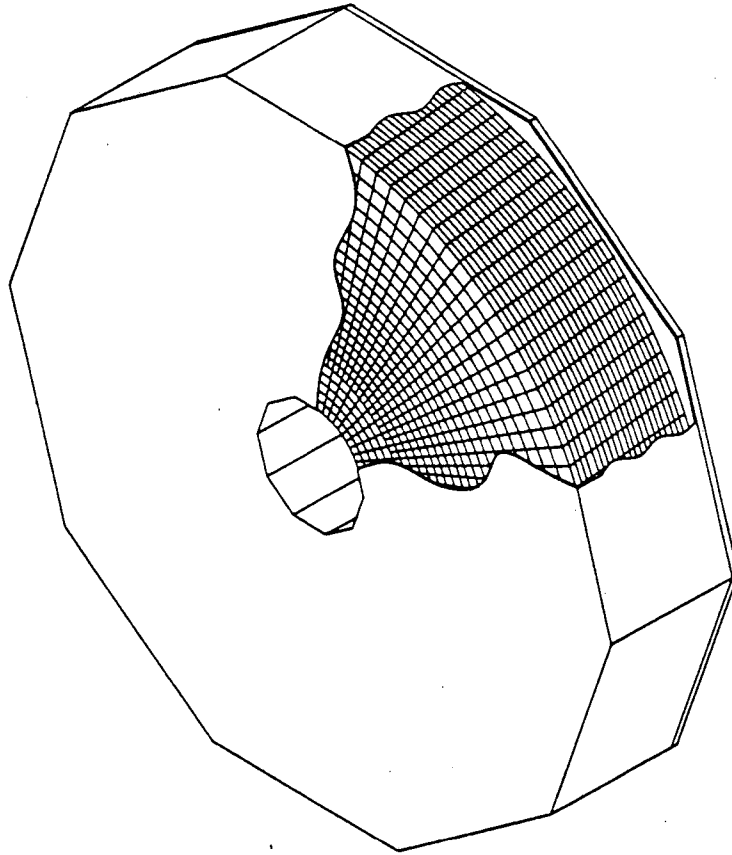

Fig. 8 Back Stop Construction
(conceptual)

TECHNICAL CHALLENGES

The technical areas in which we might benefit from industrial expertise can be summarized under the following headings:

1. Further insights into the ionization chemistry, surface reaction chemistry, and radiation damage mechanisms of Tetramethylpentane (TMP).
2. Reliable, cost-effective TMP purification and handling.
3. Cost effective fabrication of precision lead alloy absorber/electrode plates.
4. Cost effective fabrication of precision ceramic high voltage insulators.
5. Inexpensive, inert, reliable bulk resistivity materials capable of providing approximately 2 megohms resistance in a short aspect ratio configuration.
6. Optimization of 3-D high voltage holding contours and finishes.
7. High reliability Kapton high voltage insulating components. Specifically, the time dependent "pin-hole" problem.
8. Radiation damage mechanisms, especially for TMP and Kapton.
9. Moldable plastics with good radiation hardness and free of electronegative contaminants.

10. Elastomeric vessel seals with good radiation hardness and free of electronegative contaminants.
11. Clean room assembly techniques with emphasis on avoidance of selected contaminants, rather than the usual particle count approach.
12. High reliability, low cost high voltage (20 kV) and signal feedthrus.
13. Low noise, fast, solid state, radiation hard, front-end electronics. (pre-amps)

CONCLUSIONS

None of these challenges are overwhelming. Our group at LBL is convinced that warm liquid calorimetry can and will be developed to provide a highly hermetic, compensated detector which will be a significant asset for high energy physics research.

REFERENCES

1. A. Ciocio, M. Hoff, J. Kadyk, P. Limon, D. O'Neill, M. Pripstein, W. Thur, and W. Wenzel, "A Warm Liquid Calorimeter Concept for the Superconducting Super Collider," Lawrence Berkeley Laboratory Report LBID-1705, Prepared for the SSC Solenoidal Detector Collaboration General Meeting, November 6-7, 1990, Lawrence Berkeley Laboratory, Berkeley, CA. (1990).
2. J. Colas, M. Pripstein, and W. A. Wenzel, "The Electrostatic Transformer," Nuclear Instruments and Methods in Physics Research A294, Elsevier Science Publishers B.V. North-Holland, pp.583-590 (1990).

LAWRENCE BERKELEY LABORATORY
UNIVERSITY OF CALIFORNIA
INFORMATION RESOURCES DEPARTMENT
BERKELEY, CALIFORNIA 94720