

# UCLA

## UCLA Previously Published Works

### Title

Percutaneous retrieval of the locked helex septal occluder

### Permalink

<https://escholarship.org/uc/item/8kv1v6cn>

### Journal

Catheterization and Cardiovascular Interventions, 77(6)

### ISSN

1522-1946

### Authors

Poommipanit, Paul

Levi, Daniel

Shenoda, Michael

et al.

### Publication Date

2011-05-01

### DOI

10.1002/ccd.22798

### Copyright Information

This work is made available under the terms of a Creative Commons Attribution License, available at <https://creativecommons.org/licenses/by/4.0/>

Peer reviewed

# Percutaneous Retrieval of the Locked Helex Septal Occluder

Paul Poommipanit,<sup>1\*</sup> MD, Daniel Levi,<sup>2</sup> MD, Michael Shenoda,<sup>3</sup> MD,  
and Jonathan Tobis,<sup>3</sup> MD

The HELEX device is approved for percutaneous closure of an atrial septal defect (ASD). It is also often used off-label to close patent foramen ovale (PFO). The device is well tolerated because it is very flexible, but this characteristic increases the likelihood of embolization of locked implants. While the company provides a mechanism to retrieve devices that do not lock correctly, retrieval of locked and released devices is much more difficult. A case of percutaneous retrieval of an embolized, locked HELEX device is reported. This device was successfully retrieved from the aorta by snaring the left atrial eyelet and unlocking the device. A variety of potential techniques for retrieval of these devices was explored on the bench top. Strategies which can be used to successfully retrieve embolized HELEX devices are described. © 2011 Wiley-Liss, Inc.

**Key words:** patent foramen ovale/atrial septal defect; intracardiac Echo; complications adult cath/intervention

## INTRODUCTION

The percutaneous closure of an atrial septal defect (ASD) or patent foramen ovale (PFO) has become a common procedure in the cardiac catheterization lab. There have been over 200,000 Amplatzer septal occluder devices (AGA Medical, Plymouth, MN), over 10,000 HELEX septal occluder devices (Gore Medical, Flagstaff, AZ), and over 32,000 CardioSeal family of septal occluder devices (NMT Medical, Boston, MA) implanted since the mid 1990s [1–3]. Device embolization is a well described complication of all transcatheter ASD closure devices. As the frequency of implants increases, the number of embolized devices will also increase [4].

While techniques for retrieval of AGA septal occlusion devices are well described, specific techniques for transcatheter retrieval of the HELEX device have not been published. The HELEX device has a white retrieval cord which allows for easy retrieval of a device which does not lock appropriately. A device that is not locked can also be easily retrieved with a snare and the HELEX delivery sheath. Devices that are locked are much more difficult to retrieve. HELEX devices can embolize to the pulmonary arteries, cardiac chambers, or aorta. Successful retrieval of these devices requires an operator to understand the mechanics of the HELEX device and have knowledge of potential retrieval methods. This case report and bench-top study focuses on the percutaneous retrieval of the locked HELEX septal occluder device.

## CASE REPORT

A 45-year-old fireman without prior medical problems presented with right sided hemiparesis 1 week after varicose vein stripping. Magnetic resonance imaging (MRI) demonstrated a left anterior cerebral artery (ACA) occlusion. He was treated with tissue plasminogen activator (tPA) and eventually had full recovery of neurologic function. Further workup included a transcranial Doppler (TCD) study which showed a Spencer grade 5 shunt. A lower extremity ultrasound demonstrated a greater saphenous vein occlusive thrombus.

<sup>1</sup>Advanced Cardiovascular Consultants, Inc., Rock Island, Illinois

<sup>2</sup>David Geffen School of Medicine, Department of Pediatrics, Division of Cardiology, University of California, Los Angeles, California

<sup>3</sup>David Geffen School of Medicine, Department of Medicine, Division of Cardiology, University of California, Los Angeles, California

Conflict of Interest: Dr. Tobis is a consultant for AGA Medical, WL Gore, and Coherex Inc.; Dr. Levi is a consultant for pfm Medical.; Drs. Poommipanit and Shenoda have no disclosures or conflicts of interest.

\*Correspondence to: Paul Poommipanit, MD, 2525 24th St, Suite 101, Rock Island, IL 61201. E-mail: ppoommipanitmd@gmail.com

Received 11 August 2010; Revision accepted 27 August 2010

DOI 10.1002/ccd.22798

Published online 8 March 2011 in Wiley Online Library (wileyonlinelibrary.com)

Transesophageal echocardiography (TEE) revealed a PFO. He refused randomization in the RESPECT multicenter clinical trial but agreed to percutaneous PFO closure to prevent further neurologic sequelae.

After an ultrasound study demonstrated the absence of thrombus in the femoral vein, an 8- and an 11-French sheath (Terumo Medical, Somerset, NJ) were inserted in the right femoral vein. An 8-French Acuson AcuNav intracardiac echo (ICE) probe (Siemens Medical, Malvern, PA) was used to guide the placement of a HELEX 25mm septal occluder device across the inter-atrial septum (Image 1). Although the initial position appeared to be satisfactory by fluoroscopy and ICE imaging, 5 min after release of the device, the right atrial disc was observed to have slipped off of the limbus of the septum secundum and was now resting in the PFO tunnel. The width and position of the device within the PFO tunnel was felt to be stable enough to permit it to remain within the PFO until fibrous tissue formed to seal the tunnel. The retrieval cord was removed. ICE and fluoroscopy documented that the device lay across the atrial septum (Image 2a and b).

A transthoracic echo (TTE) was performed the following week and at 1 month. These showed the device was in a stable position on the inter-atrial septum. The patient was asymptomatic and returned for a TEE at 3 months. The TEE at 3-months postprocedure revealed a patent foramen ovale without visualization of the device. Fluoroscopy demonstrated that the device had embolized to the descending abdominal aorta near the renal arteries (Image 3a). The patient was brought back to the catheterization lab electively 3 days later and percutaneous retrieval of the HELEX device and PFO closure was performed.

Two 8-French sheaths were placed in the right femoral vein and a 6-French sheath (Terumo Medical) was placed in the left femoral artery. The 3,000 U of intravenous heparin was administered. The arterial site was "preclosed" using two Perclose Proglide closure devices (Abbott, Abbott Park, IL). A 10 French Flexor sheath (Cook Medical, Bloomington, IN) was inserted into the femoral artery and placed caudal to the device. Multiple views of the device in relationship to the sheath were obtained to identify the position of both atrial eyelets. A 6-French pigtail catheter (Cordis Corp, Warren, NJ) was used to perform aortography (Image 3b). A 6-French multipurpose diagnostic catheter (Cordis) with a 12–20 mm EnSnare (Angiotech Medical Device Technologies, Gainesville, FL) was unsuccessful in capturing the device. This was followed by a 6-French JR4 diagnostic catheter (Cordis) with a 3.5 mm Amplatz gooseneck snare (eV3, Plymouth, MN) to capture the left atrial (LA) eyelet, which successfully

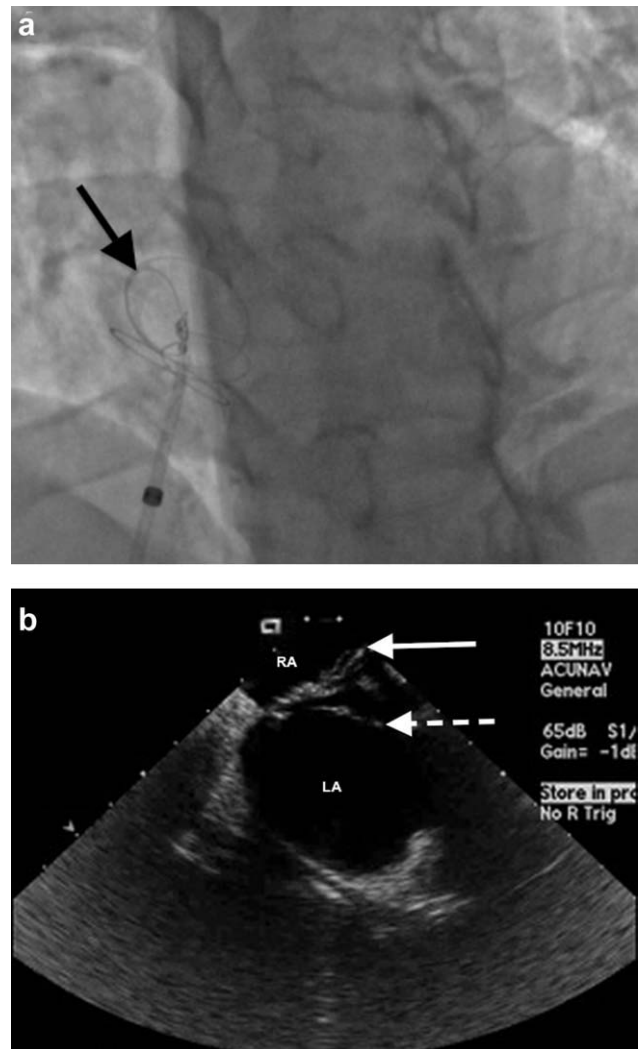

**Image 1.** (a) Fluoroscopic image of the HELEX device (black arrow) in place across the patent foramen ovale (PFO) with the right atrial disc splayed across the septum secundum. (b) Typical intracardiac echo appearance of the HELEX device with the right atrial disc (solid white arrow) and left atrial disc (dashed white arrow) straddling the septum secundum. The right atrium (RA) and left atrium (LA) are labeled.

released the locking loop and allowed the device to unravel. The embolized HELEX device was retracted into the Flexor sheath (Image 4a). The right atrial (RA) eyelet hooked on the distal tip of the sheath (Image 4b and c), which prevented the device from entering the catheter completely. Attempts to free the eyelet resulted in the snare breaking. About 4 and 7 mm microsnares (eV3) were employed but did not capture the LA eyelet within the sheath. Attempts to snare the distal RA eyelet resulted in the device advancing back into the iliac artery.

A Voyager 4.0 × 15 mm<sup>2</sup> angioplasty balloon (Abbott) was used to trap the device to the inside of

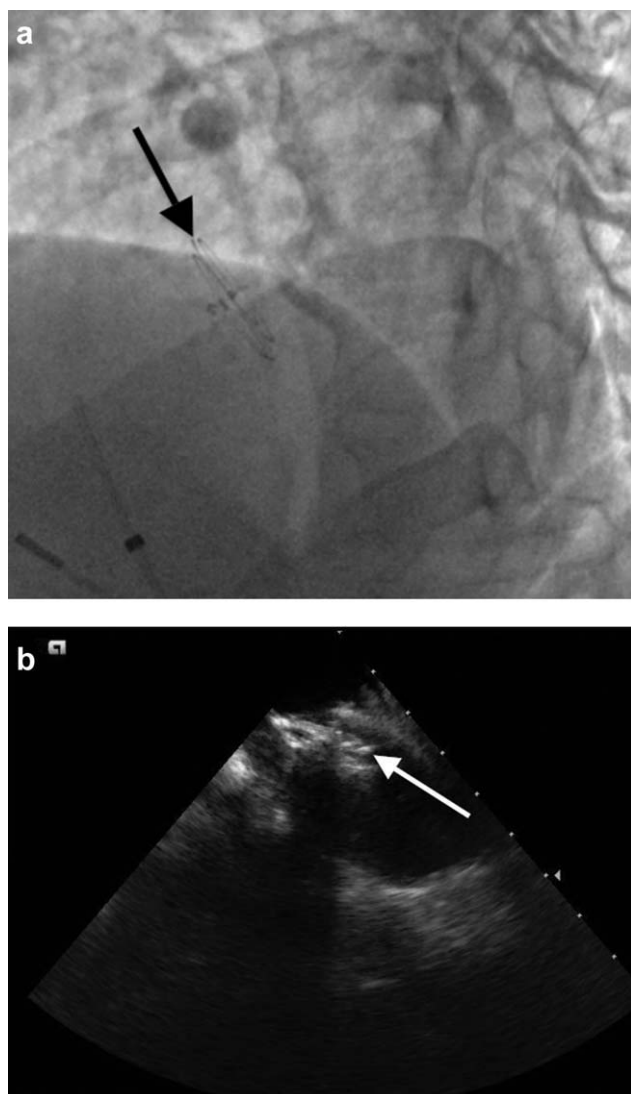

**Image 2.** (a) Fluoroscopic image of the HELEX device with the right atrial disc within the PFO tunnel (black arrow). (b) Intracardiac echo (ICE) image of the HELEX device with the right atrial disc (white arrow) within the PFO tunnel. Because of the width of the device, this was felt to be stable enough to allow for healing and fibrosis of the device within the tunnel.

the sheath. Pulling back on the balloon successfully retracted the device back into the Flexor sheath, but the RA eyelet again would not enter the catheter lumen. There was concern that, upon removal of the catheter, the device would hook on the femoral arteriotomy site and traumatize the artery. An attempt was made to advance a 0.038-in. J-wire past the device to aid with removal of the sheath, but this resulted in partial migration of the device back into the iliac artery. The Voyager balloon burst with a repeat attempt at retraction. A Voyager NC 4.5 × 15 mm<sup>2</sup> balloon (Abbott) successfully retracted the device into the sheath. The decision was made to remove the catheter and device as a unit. The sheath was pulled back until

the balloon and device were partially out of the body. Two large hemostat clamps were placed at 90° across the sheath to pin the device within the sheath. The Flexor sheath and device then were removed together. Hemostasis was achieved with the Perclose devices.

The patient's PFO was closed uneventfully with a 30-mm Amplatzer (AGA Medical) cribriform device. The patient was discharged home the same day.

### Bench Top Study

The mechanism of percutaneous retrieval of the HELEX device and the requirements from both a technical and equipment standpoint were evaluated using 25 preformed nonsterile HELEX devices of varying sizes from 15 to 35 mm diameter. The design of the HELEX device must be understood prior to undertaking percutaneous retrieval. As shown in Figs. 1–3, the HELEX septal occluder device is composed of a single nitinol wire covered by expanded polytetrafluoroethylene (e-PTFE) with a LA eyelet, center eyelet and RA eyelet. A locking loop that extends from the left atrial side to the right atrial side holds the device together after deployment. We hypothesized that the ability to retrieve the Helex device would depend on where the snare captured the device: on the RA eyelet, the LA eyelet, or around one of the e-PTFE-coated discs.

## METHODS

### *In Vitro* Retrieval of Locked Helex Devices

An embolized HELEX device can be snared from either the right or left atrial eyelet. Either the right or left atrial disc can also be snared. Thus, each of these retrieval strategies was evaluated with a range of devices and sheaths.

Because the steel braiding of the Flexor sheaths has made them a popular choice for retrieval of embolized devices, a 10-French Flexor sheath (Cook Medical) was used for baseline testing. A range of sizes of locked HELEX devices (Gore Medical, Flagstaff, AZ) from 15 to 35 mm were used to reproduce mock retrieval into the Flexor sheath. Attempts were made to capture the LA eyelet or the RA eyelet using a 5-mm gooseneck snare (eV3, Plymouth, MN) with a 6-French JR4 diagnostic coronary catheter (Cordis). The left atrial disc and right atrial disc captures were done using a 20-mm gooseneck snare (eV3) with the JR4 catheter. A single attempt was made to capture the RA eyelet with the locking loop and a single attempt was made at retraction by snaring the locking loop. The snare was placed on the desired segment of the device under direct visualization. The question was, with each snared portion of the device, how effective would be retrieval into the sheath.

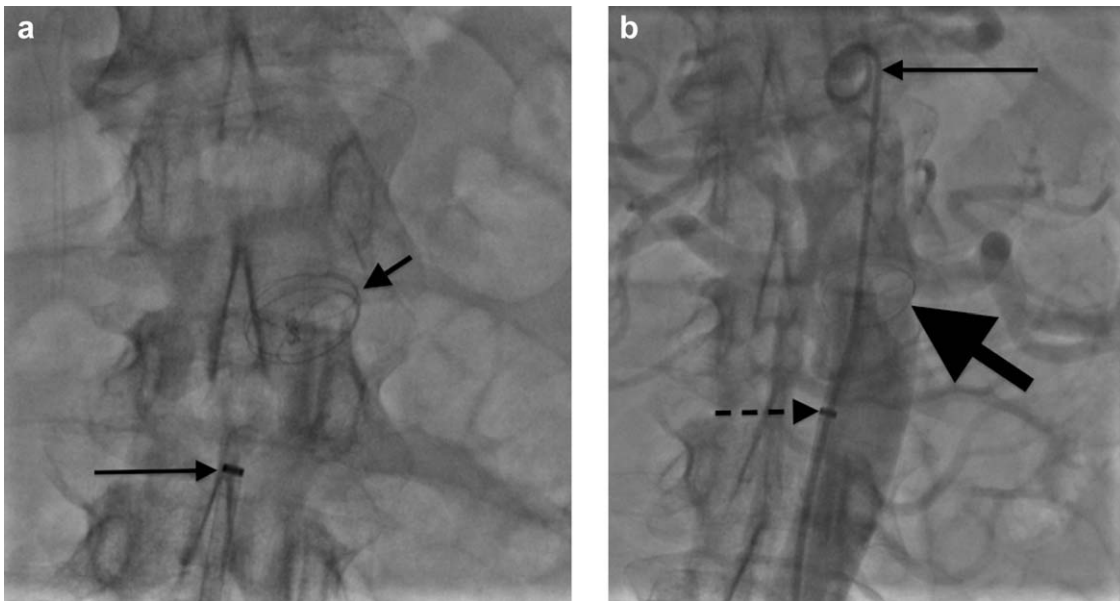

**Image 3.** (a) Fluoroscopic image of the HELEX device (short arrow) in relationship to the 10-French rescue sheath (long arrow). (b) Abdominal aortic angiography with a pigtail catheter (narrow black arrow) demonstrating the HELEX device (wide black arrow) in relationship to the Flexor sheath (dashed arrow) and the renal arteries.

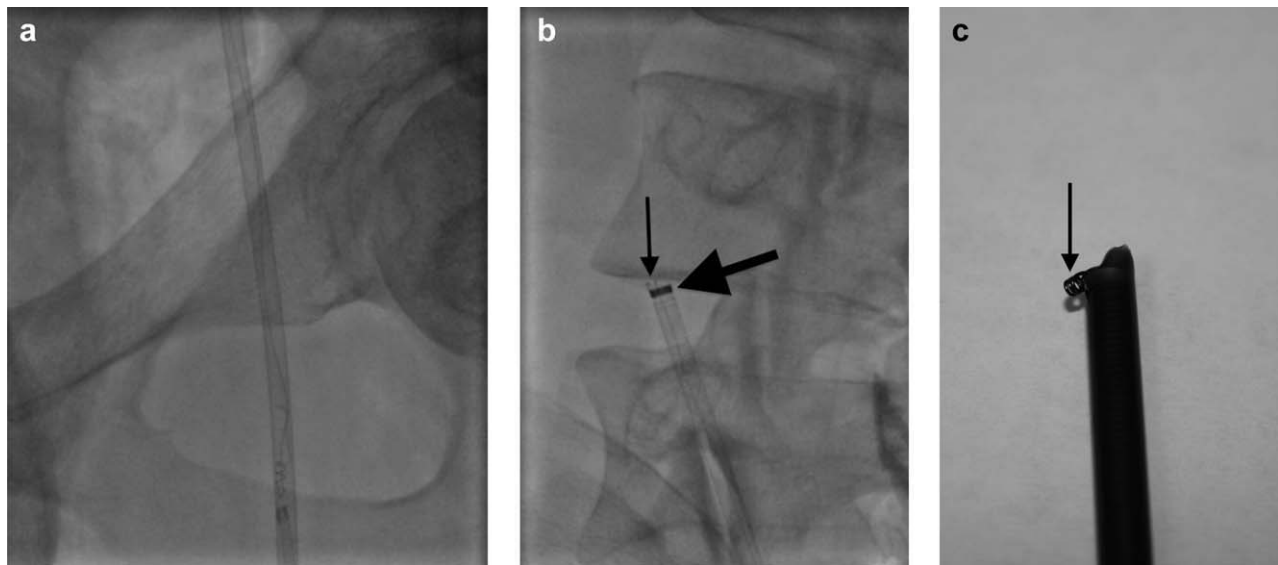

**Image 4.** (a) Left atrial side of the HELEX device retracted into the Flexor sheath. (b) Right atrial (RA) eyelet (narrow black arrow) caught on the end of the sheath (wide black arrow). (c) *In vitro* picture of the RA eyelet (narrow black arrow) caught on the end of the sheath.

A 12-French Check Flo Performer sheath (Cook) was used to snare the 25, 30, and 35 mm devices via the left atrial disc using the 20-mm gooseneck snare with the JR4 catheter. The 12-French sheath was also used for right atrial disc captures in combination with the 20-mm gooseneck snare and the JR4 catheter. Attempts were also made with an 8-French Multipurpose (MPA) coronary guiding catheter (Cordis Corp), a 9-French braided sheath (Arrow Int., Reading, PA)

and a 10-French short sheath (St. Jude Medical, St. Paul, MN).

**RESULTS**

Table I shows the results of attempts to retract the device into the sheath by snaring the LA eyelet or the RA eyelet. Capture of the locking loop together with the RA eyelet was unsuccessful in device retraction

(Image 5e). An attempt at snaring the locking loop alone was also unsuccessful.

Table II shows the results of attempts to capture the device by snaring the right atrial or left atrial disc through the 10-French Flexor sheath. Attempts to capture the left atrial disc were successful with the smaller devices, but not with larger devices. A 12-French Check Flo performer sheath (Cook Medical) was used to attempt device retrieval with all devices by right atrial disc capture and with the larger devices by snaring the left atrial disc. These results are in Table III.

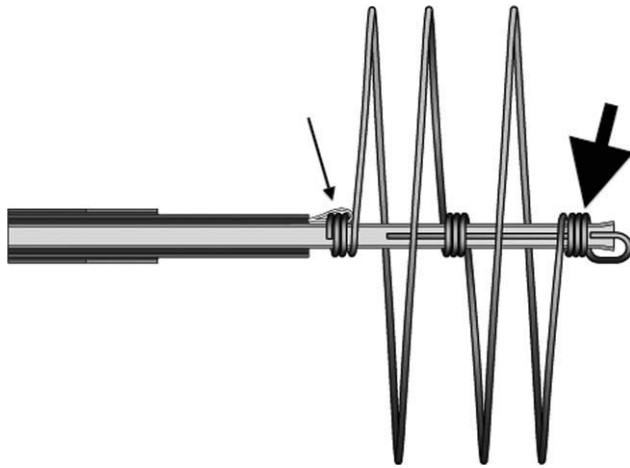

**Fig. 1.** HELEX nitinol frame with delivery catheter. The RA eyelet is identified by the narrow arrow and the LA eyelet is depicted by the wide arrow. (Figure courtesy of W.L. Gore & Associates, Inc).

An 8-French MPA coronary guiding catheter (Cordis Corp.), 9-French braided sheath (Arrow), and a 10-French short sheath (St. Jude Medical) were also used for mock retrievals. The 8-French coronary guiding catheter was too small to allow any device retraction. The middle islet got stuck at the tip of the 10-French short sheath and the 9-French Arrow braided sheath.

## DISCUSSION

In the US Multicenter Pivotal Trial Study of the HELEX septal occluder device for ASD closure, the rate of embolization was 1.7% [5]. A case report documenting embolization of a HELEX device for ASD closure ultimately required surgical intervention for device retrieval from the pulmonary artery, despite multiple attempts with retrieval forceps, biptomes and snares [6]. In a single center study of HELEX device implantation for PFO closure, none of the devices embolized, but percutaneous retrieval was performed using a 25-mm goose-neck snare when the intrinsic retrieval system failed [7].

Operators who perform percutaneous septal occluder implantation must be familiar with techniques for device retrieval for early and late embolizations. While techniques for Amplatzer device retrieval have been described [8], techniques for retrieval of the locked HELEX device are less familiar. Immediate retrieval of a Helex device that does not lock appropriately is feasible with the attached retrieval cord (Fig. 2). While retrieval of locked devices is possible with both 10 and 12 Fr sheaths, it

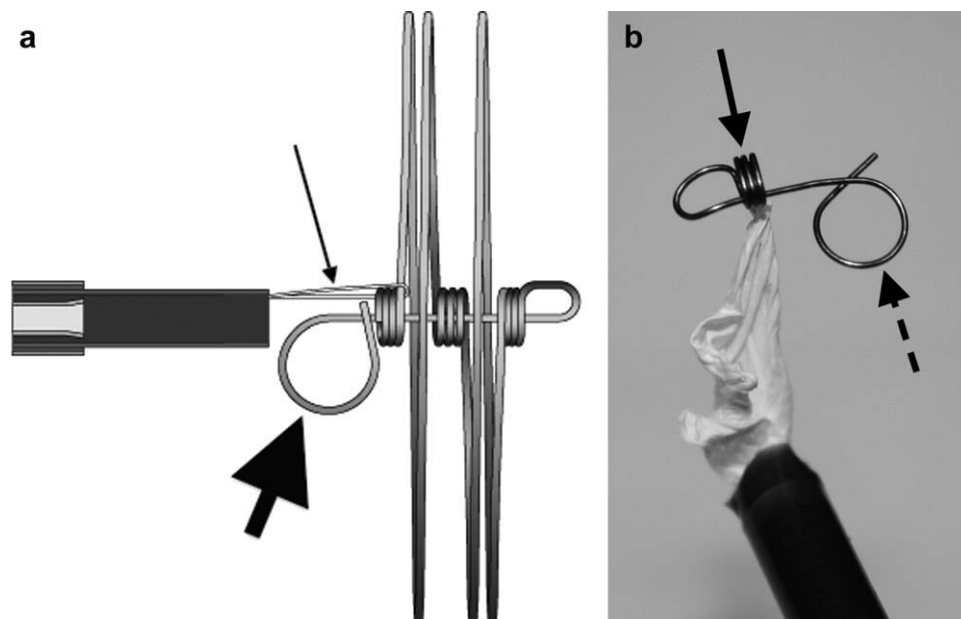

**Fig. 2.** (a) Locked HELEX nitinol frame prior to final release. The retrieval cord is indicated by the narrow arrow and the locking loop is marked by the wide arrow. (Figure courtesy of W.L. Gore & Associates, Inc). (b) Picture of LA eyelet (solid arrow) with locking loop (dashed arrow).



Fig. 3. HELEX septal occluder device prior to retraction within the delivery sheath (Figure courtesy of W.L. Gore & Associates, Inc). [Color figure can be viewed in the online issue, which is available at [wileyonlinelibrary.com](http://wileyonlinelibrary.com).]

does require knowledge of both specific retrieval techniques and of the device's mechanical construction. If the HELEX device can be successfully unlocked and unraveled during retrieval, it can be easily retracted into a 10 Fr sheath. Strategies which do not unlock the device are made easier with larger sheaths.

As would be expected from the device's locking mechanism, snaring of the LA eyelet, which is attached to the locking loop, resulted in successful retrieval with all device sizes *in vitro* and of the embolized device *in vivo*. As demonstrated in Fig. 2, the locking loop that holds the device together originates from the left atrial side, thus pulling the device from this side unlocks the lock mechanism and permits the device to unravel. When this strategy was used for device retrieval, the RA eyelet was the last part of the device to be pulled into the rescue sheath. Both on the bench-top and in our case report, the RA eyelet wire loop caught on the end of the sheath in many of the retrieval attempts (Image 6c). This did not prevent removal of the device from the body but it is helpful to know that the end of the device may need to be reoriented for successful retrieval of the entire device into a sheath.

In contrast, RA eyelet capture was extremely difficult to accomplish *in vitro* without capturing the locking loop as well. If the RA eyelet is captured without the locking loop, devices 20mm or larger can be retracted into a 10-French Flexor sheath. This is the same mechanism that is used for device retrieval via the retrieval cord. As seen in Fig. 2, the cord is attached to the RA eyelet. Even after deployment of the locking loop by removal of the mandrel, the device can potentially be retrieved with this cord. By pulling

TABLE I. Right Atrial (RA)<sup>a</sup> and Left Atrial (LA) Eyelet Capture Through a 10-French Flexor Sheath<sup>b</sup>

Size of helix (mm)	Sheath size (Fr)	RA eyelet capture	LA eyelet capture
15	10 Cook	Locking loop caught	Pulled in to RA eyelet
20	10 Cook	Came in completely	Pulled in to RA eyelet
25	10 Cook	Came in completely	Pulled in completely
30	10 Cook	Came in completely	Pulled in completely
35	10 Cook	Came in completely	Pulled in to RA eyelet

<sup>a</sup>Note that RA eyelet capture denotes sole RA eyelet capture, which is highly unlikely *in vivo*. The PTFE and locking loop of the device obstruct access to the RA eyelet, thus RA eyelet + locking loop capture is most likely.

<sup>b</sup>Cook Medical, Bloomington, IN.

on the cord, the RA eyelet is pulled through the locking loop and thus unlocks the device. The right atrial disc simply needs to be pulled into the delivery sheath. The cause for the unsuccessful retrieval of the 15-mm device via the RA eyelet may be related to the device size affecting the orientation of the locking loop as it passes the distal end of the sheath. *In vivo*, sole RA eyelet capture would be very unlikely since the locking loop and PTFE obstructs access to the RA eyelet. Snaring of the RA eyelet along with the locking loop is more likely to occur due to their proximity. This would not result in successful retrieval since the device would not unlock. The RA eyelet and locking loop would respond as a large intact unit and lodge at the distal end of the retrieval sheath (Image 6a). Snaring of the locking loop itself resulted in loss of capture of the locking loop without device retraction. The locking loop straightens as it is being pulled back toward the sheath and recoils back to its original position, relocking the RA eyelet to the device.

As distinguished from capture of the RA or LA eyelet, right atrial disc capture *in vitro* through the 10-French Cook sheath was unsuccessful. The locking loop was too large to enter the sheath with all device sizes. The 12-French Cook sheath was successful in device retrieval from the right atrial disc with the larger devices. It is unclear why the larger devices retract into the sheath from the right atrial side. One hypothesis is that it may be related to the device size affecting the orientation of the locking loop as it passes the distal end of the sheath. *In vivo*, capture of the right atrial disc may be more easily accomplished with a clamp or saw-toothed forceps, rather than with a gooseneck snare, especially with the larger devices.

Capture of the opposing left atrial disc through the 10-French sheath was successful with the two smaller devices (15, 20 mm), however retrieval was unsuccessful with the larger devices. This is likely a function of the bulk of the larger sizes, since the left atrial eyelet, PTFE and a portion of the left atrial disc frame all need to come into the sheath at the same time. The 12-French

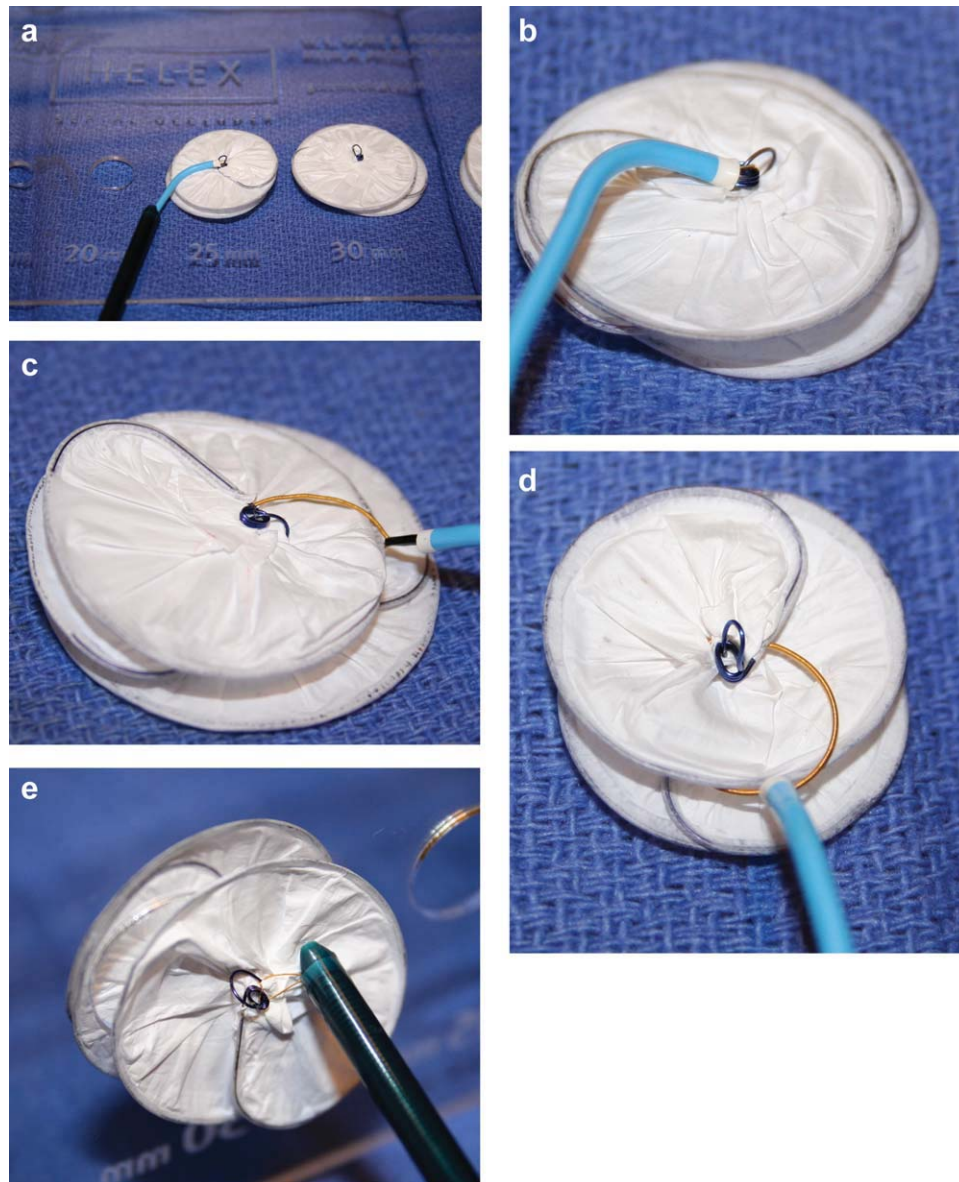

**Image 5.** Photographic depiction of snaring the (a) left atrial (LA) eyelet, (b) RA eyelet, (c) right atrial disc, and (d) left atrial disc. The easiest and most reliable way to retrieve the device into a 10-French stiff-tip sheath is by capturing the LA eyelet. Capture of the RA eyelet alone is highly unlikely in vivo, with the typical result being the capture of the (e) RA eyelet together with the locking loop. Capture of either disc requires the use of a 12-French sheath for successful retrieval. [Color figure can be viewed in the online issue, which is available at [wileyonlinelibrary.com](http://wileyonlinelibrary.com).]

sheath resulted in successful retraction of these larger devices after snaring the left atrial disc.

It was observed that only sheaths with stiff tips were successful for retrieval as soft tipped sheaths buckled and would not support devices as they were withdrawn into the distal aperture of the catheter. The 9-French braided sheath and 10-French short sheaths had fairly soft distal tips and did not allow the middle eyelet to pass into the sheath. The eyelet simply imbedded into the end of the sheath (Image 6b).

**TABLE II. Right and Left Atrial Disc Capture With a 10-French Flexor Sheath<sup>a</sup>**

Size of helex (mm)	Sheath size (Fr)	Right atrial disc capture	Left atrial disc capture
15	10 Cook	Blocked at locking loop	Came in completely
20	10 Cook	Blocked at locking loop	Came in completely
25	10 Cook	Blocked at locking loop	Failed
30	10 Cook	Blocked at locking loop	Failed
35	10 Cook	Blocked at locking loop	Failed

<sup>a</sup>Cook Medical, Bloomington, IN.



**TABLE III. Right and Left Atrial Disc Capture Using a 12-French Sheath<sup>a</sup>**

Size of helex (mm)	Sheath size (Fr)	Right atrial disc capture	Left atrial disc capture
15	12Fr Cook Check Flo Performer	Caught mid islet, failed	Not performed
20	12Fr Cook Check Flo Performer	Came in completely	Not performed
25	12Fr Cook Check Flo Performer	Came in completely	Came in completely
30	12Fr Cook Check Flo Performer	Came in completely	Came in completely
35	12Fr Cook Check Flo Performer	Came in completely	Came in completely

<sup>a</sup>Cook Medical, Bloomington, IN.

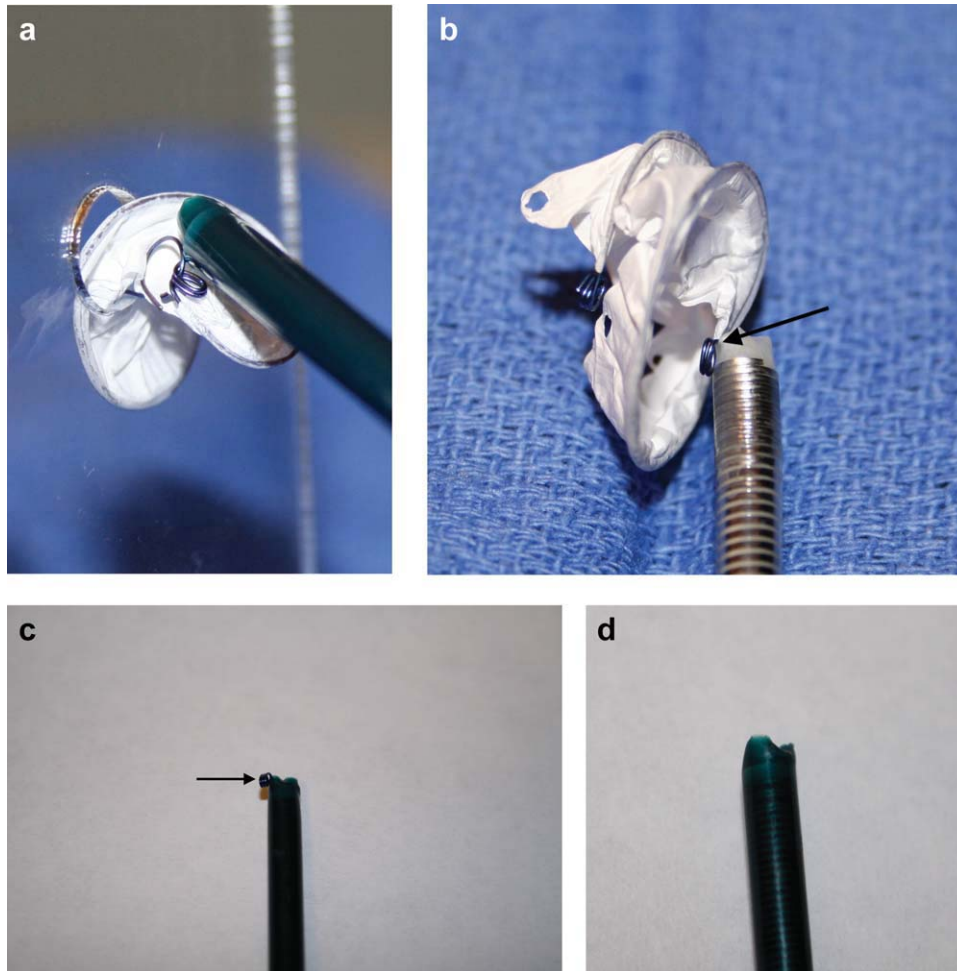

**Image 6.** Photographic representation of (a) entire device blocked at the sheath tip, (b) the middle eyelet (arrow) caught on a sheath tip, (c) the RA eyelet (arrow) caught on the sheath tip and (d) the entire device retracted into the rescue sheath. Figures and devices used for benchtop studies provided courtesy of W.L. Gore & Associates, Inc. [Color figure can be viewed in the online issue, which is available at [wileyonlinelibrary.com](http://wileyonlinelibrary.com).]

## CONCLUSIONS

Although embolization of septal occluder devices for ASD or PFO closure is a rare occurrence, operators must be prepared for early and late embolizations. Percutaneous retrieval of a HELEX septal occluder device is possible with the right equipment and techniques. In our experience, pulling the device from the LA eyelet releases the lock mechanism and permits the device to

be pulled through a smaller 10-French sheath. Successful retraction of the device by grabbing the left atrial disc is dependent on the device size. The 15 mm and 20 mm devices can be retrieved through a 10-French sheath; however the larger devices need to be removed with a 12-French sheath. This retrieval catheter size differential may be important depending on the size of the patient and the size of the femoral artery. A 12-French sheath is required to retrieve any device larger

than 15 mm when the right atrial side is snared. The right atrial disc is easier to snare than the right atrial eyelet alone. In all cases, a sheath with a stiff tip is required to successfully accomplish percutaneous retrieval of the HELEX septal occluder device.

## REFERENCES

1. Available at: [http://www.amplatz.com/products/asd\\_devices/tabid/179/default.aspx](http://www.amplatz.com/products/asd_devices/tabid/179/default.aspx)
2. Available at: [www.goremedical.com/resources/dam/assets/AN1014EN1.HLX.NEWSLETTERFall09.FNL.MR.singles.pdf](http://www.goremedical.com/resources/dam/assets/AN1014EN1.HLX.NEWSLETTERFall09.FNL.MR.singles.pdf)
3. Available at: <http://www.snl.com/irweblinkx/FinancialDocs.aspx?iid=4148066>
4. Poommipanit P, Tobis J. Atrial septal defect and patent foramen ovale closure: A brief review. *Cardiol Int* 2009; (Spring):10–14.
5. Jones TK, Latson LA, Zahn E, Fleishman CE, Jacobson J, Vincent R, Kanter K; Multicenter Pivotal Study of the HELEX Septal Occluder Investigators. Results of the US multicenter pivotal study of the HELEX septal occluder for percutaneous closure of secundum atrial septal defects. *J Am Coll Cardiol* 2007;49:2215–2221.
6. Peuster M, Reckers J, Fink C. Secondary embolization of a Helex occluder implanted into a secundum atrial septal defect. *Catheter Cardiovasc Interv* 2003;59:77–82.
7. Ponnuthurai FA, van Gaal WJ, Burchell A, Mitchell A, Wilson N, Ormerod O. Single centre experience with GORE-HELEX septal occluder for closure of PFO. *Heart Lung Circ* 2009;18:140–142.
8. Levi DS, Moore JW. Embolization and retrieval of the Amplatz septal occluder. *Catheter Cardiovasc Interv* 2004;61:543–547.