

UC Davis
Civil & Environmental Engineering

Title

ANALYTICAL AND CENTRIFUGE STUDIES LATERALLY LOADED SINGLE PILES

Permalink

<https://escholarship.org/uc/item/8dr0v9j8>

Authors

Chandrasekaran, V.S.

Kulkarni, K.R.

King, G.J.W.

Publication Date

1984-07-18

Peer reviewed

Proceedings of the
SYMPOSIUM ON RECENT ADVANCES
IN GEOTECHNICAL CENTRIFUGE MODELING

A symposium on Recent Advances in Geotechnical Centrifuge Modeling was held on July 18-20, 1984 at the University of California at Davis. The symposium was sponsored by the National Science Foundation's Geotechnical Engineering Program and the Center for Geotechnical Modeling at the University of California at Davis.

The symposium offered an opportunity for a meeting of the International Committee on Centrifuges of the International Society for Soil Mechanics and Foundation Engineering. The U.S. participants also met to discuss the advancement of the centrifuge modeling technique in the U.S. A request is being transmitted to the American Society of Civil Engineers to establish a subcommittee on centrifuges within the Geotechnical Engineering Division.

ANALYTICAL AND CENTRIFUGE STUDIES
ON Laterally LOADED SINGLE PILES

V. S. Chandrasekaran
Professor of Civil Engineering
Indian Institute of Technology
Bombay, India.

K. R. Kulkarni
Professor of Civil Engineering
Indian Institute of Technology
Bombay, India.

G. J. W. King
Senior Lecturer in Civil Engineering
The University of Liverpool
Liverpool, U.K.

Presented at the International Symposium on
Recent Advances in Geotechnical Centrifuge Modelling
University of California, Davis, USA
18-20 July, 1984.

S Y N O P S I S

A semi-analytical approach based on harmonic representation of displacements in the circumferential direction and finite element discretisation of the medium in the radial and vertical direction has been used to develop dimensionless parameters for the analysis of laterally loaded single piles. Parameters are given for piles embedded in half-space in which the elastic modulus is either constant or proportional to depth.

Results of centrifuge tests on laterally loaded single piles embedded in medium dense dry sand are compared with those computed using subgrade reaction and elastic continuum models. It is observed that the elastic theories are applicable at deflection levels of less than about one-half to one per cent pile diameter.

1. Introduction

Analysis of piles subjected to lateral loads is commonly carried out by replacing the soil support either by a spring bed or by an elastic continuum. The spring bed model has been studied by many investigators and has been refined to consider variations of horizontal subgrade reaction with depth (e.g. Reese and Matlock 1957, Davisson and Gill 1963). For cohesionless soil it is considered adequate to assume that the horizontal subgrade reaction is proportional to depth and based on field and laboratory data, several recommendations have been made in regard to the value of the proportionality constant n_h (Terzaghi 1955, Reese et al 1974, Davisson and Sulley 1970). Procedures for considering the non-linear behaviour of soil have also been introduced in this model through the use of p-y curves.

Solutions based on continuum model were first obtained by Poulos (1971) using Mindlin's solution for horizontal load within a homogeneous half-space. Recently the boundary element method (Banerjee and Davis 1978) has been applied to the problem of laterally loaded piles. In these approaches arbitrary inhomogeneity in the soil deposit cannot be considered. The finite element method based on harmonic representation of displacements in circumferential direction can be used for analysing a pile subjected to a lateral load. Randolph (1981) used linear strain triangular elements and proposed simple expressions for analysing flexible piles.

In the first part of the present paper dimensionless

parameters based on finite element analysis are presented in simple form for analysing the behaviour of flexible piles in homogeneous elastic half-space and in a half-space in which the elastic modulus is proportional to depth.

In the second part of this paper results of lateral load tests on single piles carried out in a centrifuge are presented and discussed with a view to identify some of the main trends in the pile behaviour.

2. Parametric Study on Long Piles

In many instances it may be expedient to assume that the modulus of elasticity of soil either remains constant with depth or has a value proportional to depth. For both of these situations the results of the analysis may be conveniently presented using simple dimensionless influence factors. Here results of a parametric study for long piles is presented. The effect of variation of Poisson's ratio of the soil is also investigated.

Homogeneous Medium

Consider a pile as shown in Fig. 1 subjected to a horizontal load P_t and a moment M_t . When the soil medium is homogeneous it is convenient to define a characteristic length T given by

$$T = \sqrt[4]{\frac{EI}{E_s}} \quad \dots (1)$$

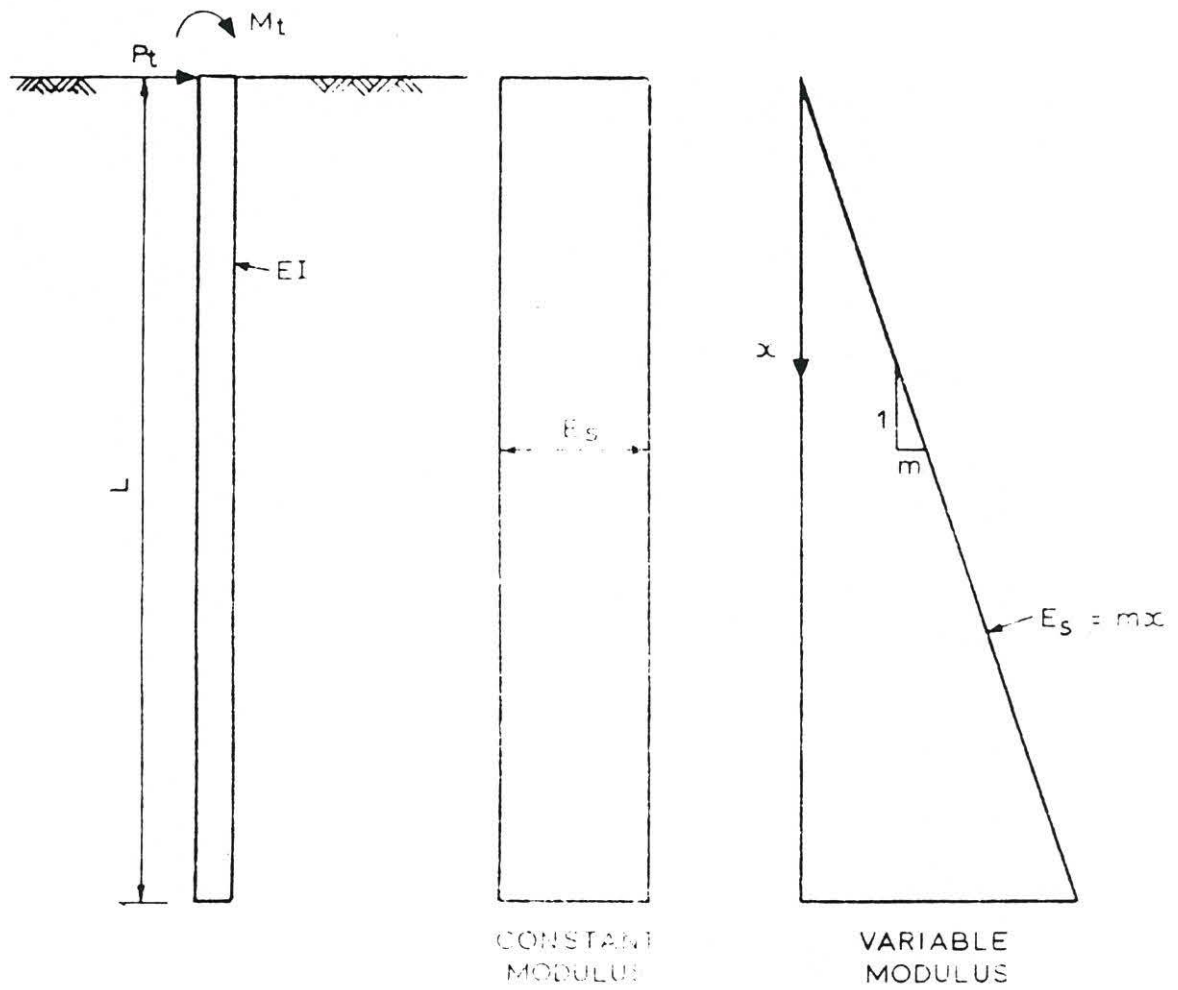

Fig.1 Soil Modulus Variation Adopted in Parametric Study

in which EI is the flexural rigidity of pile and E_s is the Young's modulus of the soil.

For given values of L/T , T/D and ν_s , and for a particular depth $x = XT$, expressions for deflection y , slope θ , bending moment M , shear force V and soil pressure p can be written as follows :

$$y = (P_t T^3/EI) A_y + (M_t T^2/EI) B_y$$

$$\theta = (P_t T^2/EI) A_s + (M_t T/EI) B_s$$

$$M = (P_t T) A_m + M_t B_m \quad \dots (2)$$

$$V = P_t A_v + (M_t/T) B_v$$

$$P = (P_t/T) A_p + (M_t/T^2) B_p$$

From a practical point of view values of A_y , A_s , B_y , B_s at the top of the pile and the variation of A_m and B_m with depth are of importance. Finite element analysis using eight noded elements and harmonic representation of displacements in circumferential direction was employed to evaluate these values (Chandrasekaran and King, 1982). Tables 1 and 2 give the values of A_y , A_s , B_y and B_s for $L/T = 5$ and $T/D = 2, 5, 10$ and 20 for values of Poisson's ratio equal to 0.47 and 0.1 respectively. For Poisson's ratio equal to 0.47 the variations of influence factors A_m and B_m with depth factor X are presented in Figs. 2 and 3 respectively.

Table 1

Dimensionless Influence Factors for Piles in a
Homogeneous Elastic Continuum

$L/T \geq 5$ $\nu_s = 0.47$ $X = 0.0$

| T/D | A_y | A_s | B_y | B_s |
|-----|-------|---------|-------|---------|
| 2 | 0.737 | - 0.557 | 0.557 | - 0.986 |
| 5 | 1.063 | - 0.783 | 0.783 | - 1.230 |
| 10 | 1.262 | - 0.897 | 0.897 | - 1.325 |
| 20 | 1.411 | - 0.974 | 0.974 | - 1.384 |

Table 2

Dimensionless Influence Factors for Piles
in a Homogeneous Elastic Medium

$L/T \geq 5$ $\nu_s = 0.1$ $X = 0.0$

| T/D | A_y | A_s | B_y | B_s |
|-----|-------|---------|-------|---------|
| 2 | 0.768 | - 0.578 | 0.578 | - 0.976 |
| 5 | 1.067 | - 0.780 | 0.780 | - 1.220 |
| 10 | 1.258 | - 0.886 | 0.886 | - 1.311 |
| 20 | 1.404 | - 0.961 | 0.961 | - 1.370 |

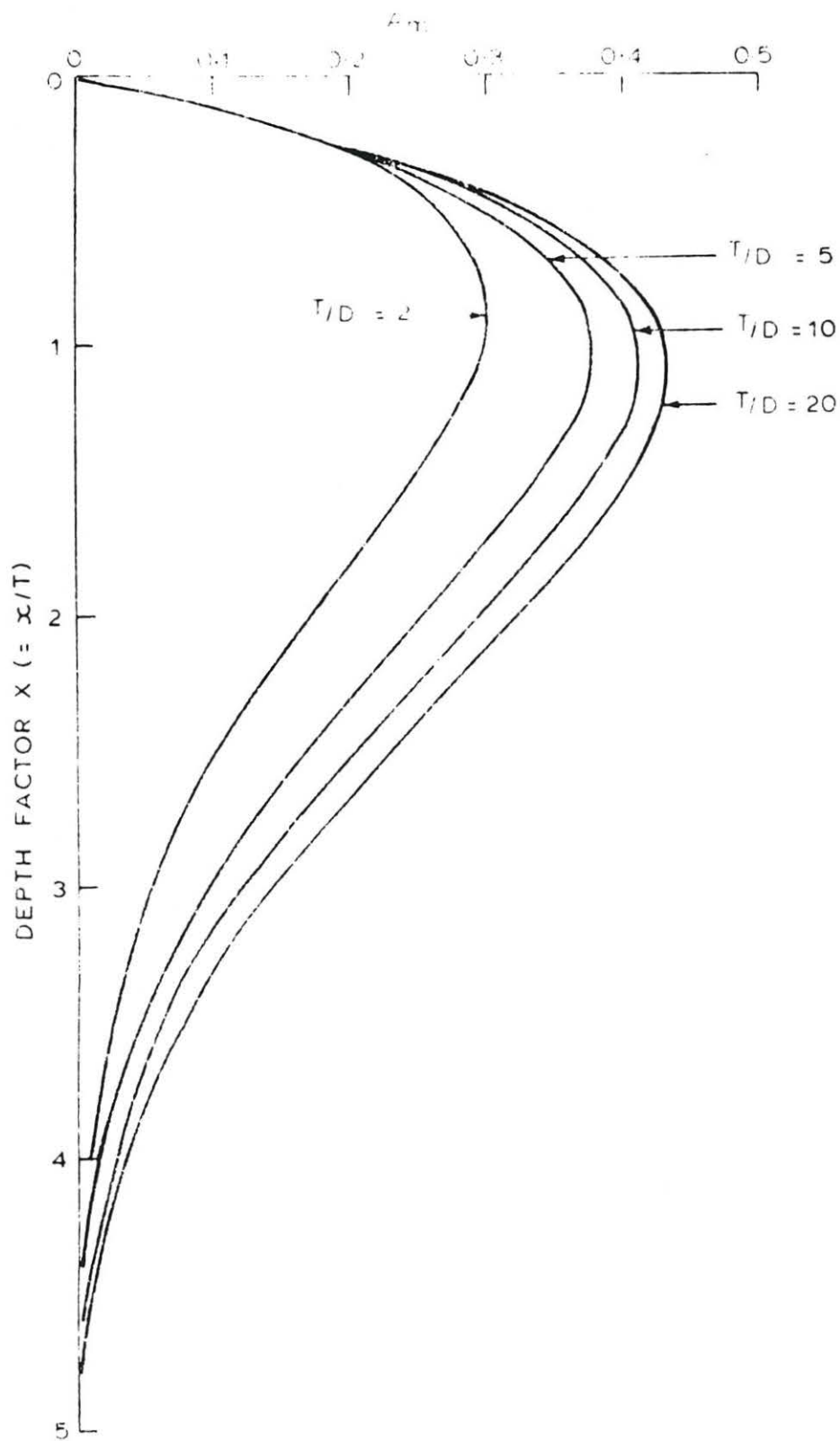

Fig.2 Variation of A_m with Depth Factor for a Homogeneous Medium

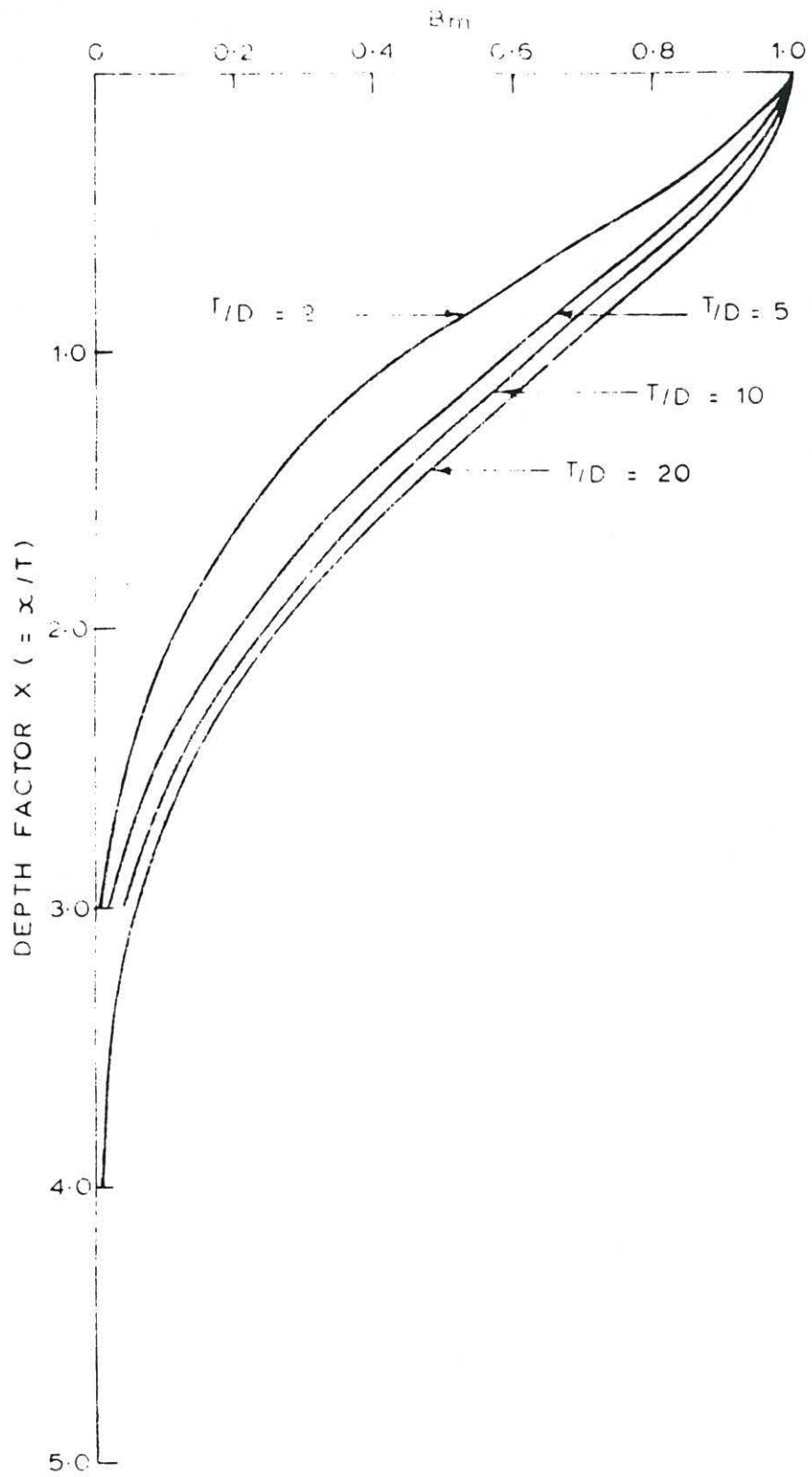

Fig.3 Variation of B_m with Depth Factor for a Homogeneous Medium

Inhomogeneous Medium

Consider a soil medium in which Young's modulus E_s varies according to the equation

$$E_s = mx \quad \dots (3)$$

where x is the depth from the soil surface. For a pile having flexural rigidity EI embedded in the medium it is convenient to define a characteristic length T , as

$$T = \sqrt[5]{\frac{EI}{m}} \quad \dots (4)$$

For given values of L/T , T/D and ν_s and for a particular depth $x = XT$, expressions for deflection y , slope θ , bending moment M , shear force V and soil pressure p can again be written by Eqs. (2) but with T given by Eq. (4).

Tables 3 and 4 give the values of A_y , A_s , B_y and B_s at the top of the pile for values of $T/D = 2, 5, 10$ and 20 for Poisson's ratio equal to 0.47 and 0.1 respectively. For Poisson's ratio equal to 0.47 the variation of A_m and B_m with depth factor X are presented in Figs. 4 and 5 respectively.

This parametric study indicates that the effect of Poisson's ratio on the behaviour of piles subjected to lateral loads is not significant and for the same flexural rigidity and soil modulus, piles of larger diameter give less deflection and bending moment.

Table 3

Dimensionless Influence Factors for Piles
in Inhomogeneous Elastic Medium with $E_s = mx$

$L/T \geq 5$ $\nu_s = 0.47$ $X = 0.0$

| T/D | A_y | A_s | B_y | B_s |
|-----|-------|---------|-------|---------|
| 2 | 1.285 | - 0.974 | 0.974 | - 1.254 |
| 5 | 1.804 | - 1.289 | 1.289 | - 1.541 |
| 10 | 2.099 | - 1.441 | 1.441 | - 1.636 |
| 20 | 2.310 | - 1.543 | 1.543 | - 1.695 |

Table 4

Dimensionless Influence Factors for Piles in
Inhomogeneous Elastic Medium with $E_s = mx$

$L/T \geq 5$ $\nu_s = 0.1$ $X = 0.0$

| T/D | A_y | A_s | B_y | B_s |
|-----|-------|---------|-------|---------|
| 2 | 1.334 | - 0.998 | 0.998 | - 1.263 |
| 5 | 1.814 | - 1.287 | 1.287 | - 1.535 |
| 10 | 2.099 | - 1.433 | 1.433 | - 1.627 |
| 20 | 2.310 | - 1.534 | 1.534 | - 1.687 |

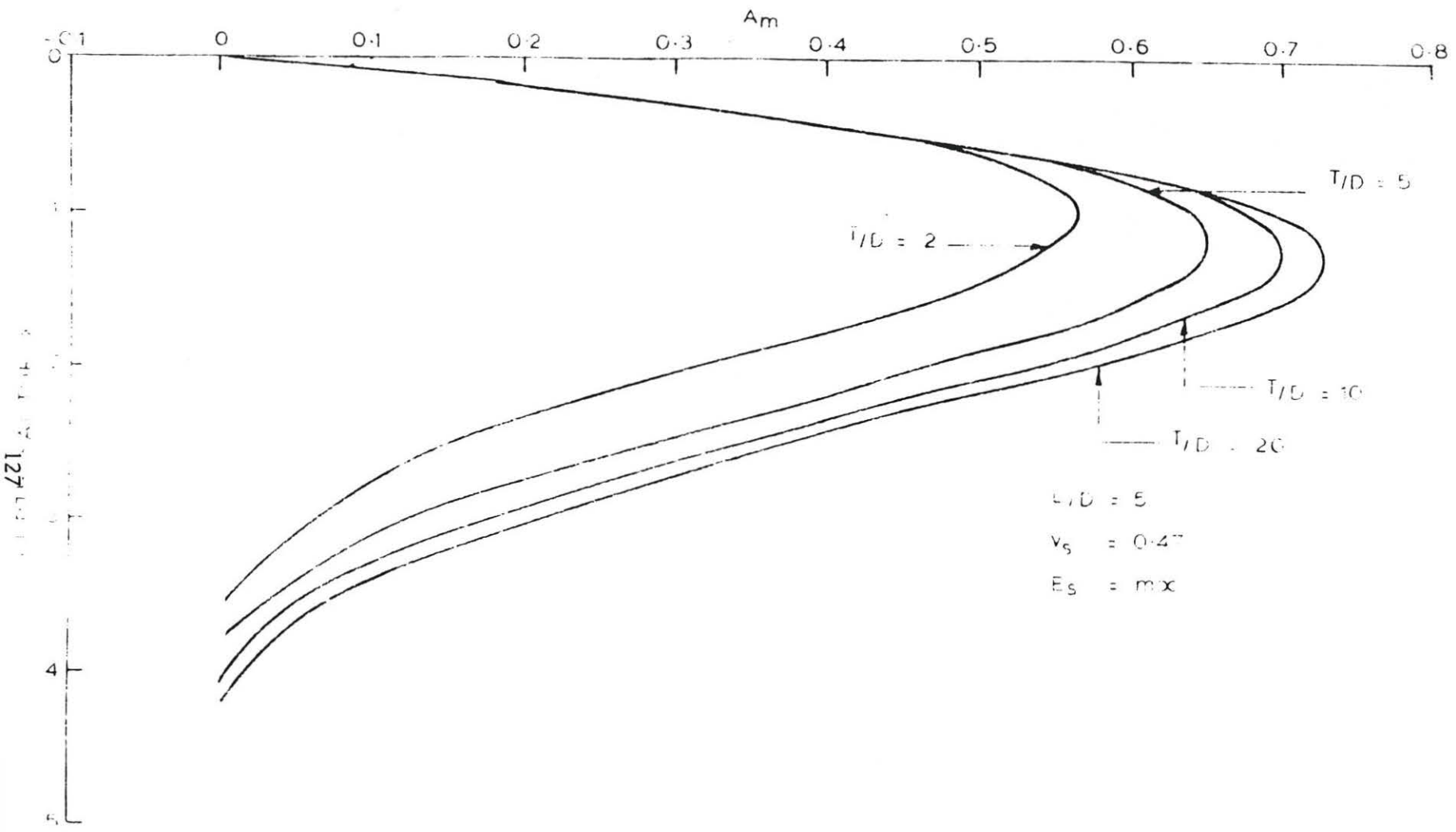

Fig.4 Variation of A_m with Depth Factor for an Inhomogeneous Medium

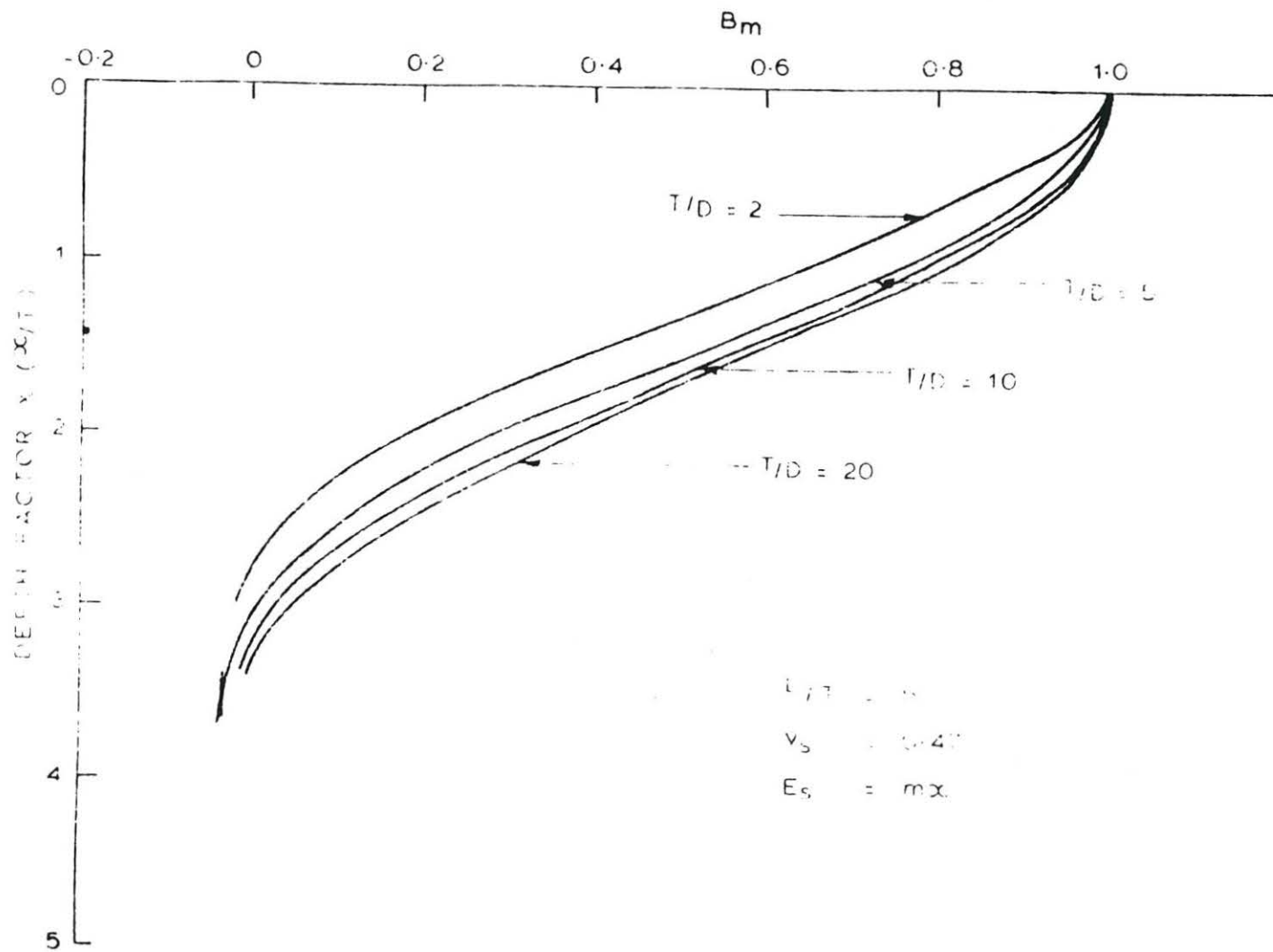

Fig.5 Variation of B_m with Depth Factor for an Inhomogeneous Medium

3. Centrifuge Experiments on Laterally Loaded Piles in Sand

3.1 Centrifuge

The behaviour of piles subjected to lateral loads may be conveniently studied by conducting experiments in centrifuge on scaled models. The modelling principle is dealt with in a number of recent publications (see for example Schofield, 1980).

The experiments were carried out in the centrifuge at Liverpool University, U.K. A detailed description of this centrifuge is given by King, et al (1984). The machine, a model G.380.3A supplied in 1974 by Triotech. Inc. of California, USA is shown diagrammatically in Fig. 6. The original fixed carriages were replaced with swinging buckets in 1979. The swinging buckets are 0.57 m long, 0.46 m wide and 0.23 m deep. The swinging buckets have an effective radius of 1.15 m and can be operated at an acceleration of 115 g.

Soil used in the Investigation

The soil used in the investigation was dry sand fine grained and uniform. It had an effective size of 150 microns and uniformity coefficient of 1.5. About 80 per cent by weight had particle sizes between 150 and 250 microns. The sand was compacted in layers of 25 to 40 mm thickness using hand vibrator with base dimensions of 100 mm x 150 mm. The unit weight of sand as compacted was 16 kN/m^3 . Reasonable reproducibility of the results was ensured.

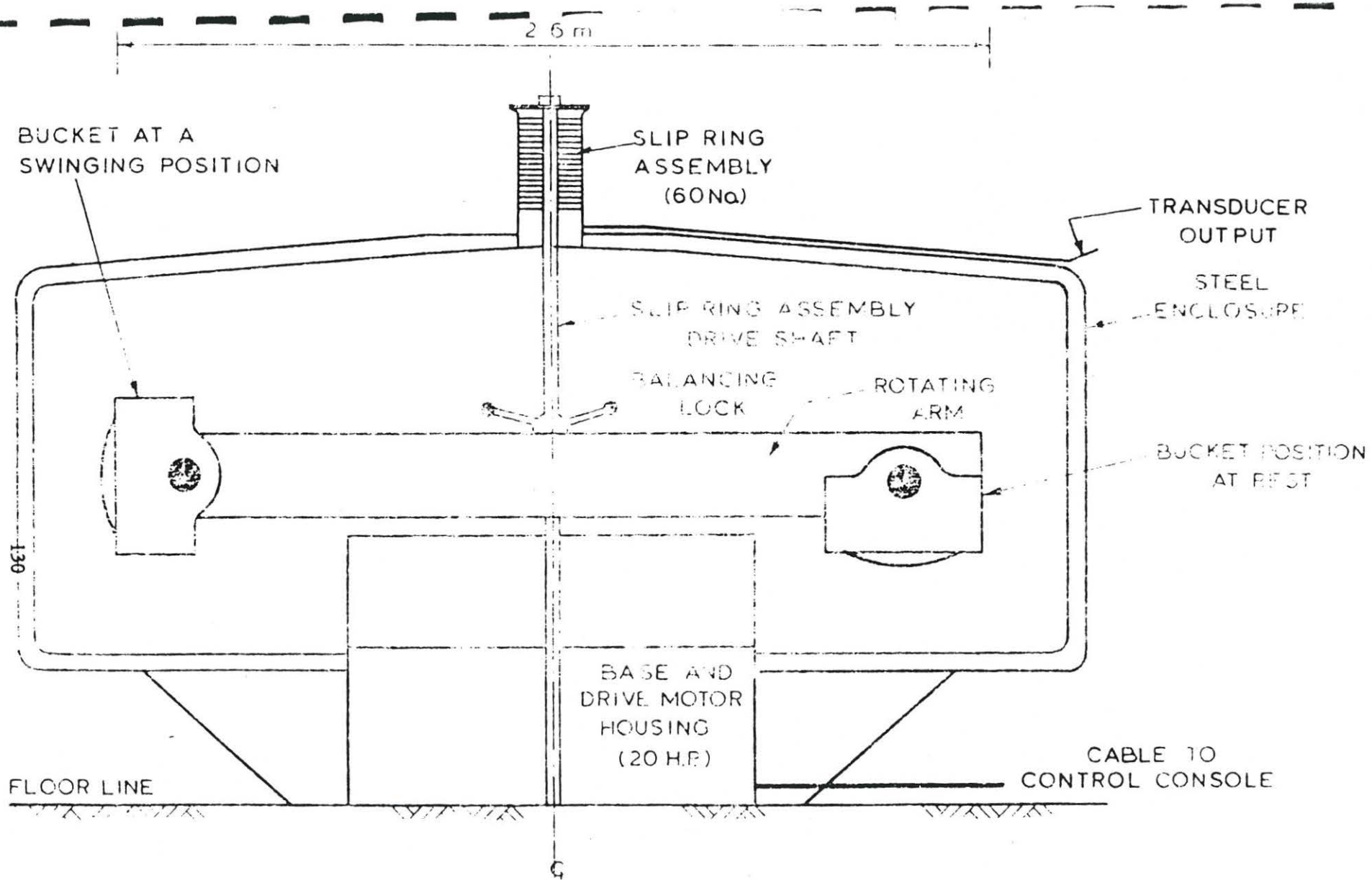

Fig.6 University of Liverpool Centrifugal Test Facility

Pile Properties

The actual dimensions adopted for the model piles were 24.5872 mm OD, 0.3048 mm wall thickness and 330 mm length. The pile had an embedded length of 180 mm. The material of the pile was 304-SS grade stainless steel with an Young's modulus value of 1.9284×10^8 kN/m².

The model piles were instrumented with 12 pairs of strain gauges. The strain gauges used were Welwyn make, type EA-125 having a gauge length of 3 mm and a resistance of 120 ohms. They were fixed internally in the tubular section according to the procedure described by King, et, al (1984). Calibration was done in cantilever position by suspending known weights at the free end and recording the half-bridge output of individual gauges. All gauges gave near perfect linear output in several cycles of loading/unloading.

Lateral Load Application

The application of lateral load to the pile cap was through a cable attached to a gear box which is operated by a 18.6 W, single phase A.C. permanent capacitor reversible motor. The gear box gives a speed reduction from 2800 to 8 rpm. The motor is operated externally through slip rings.

The applied lateral load was measured by means of a 500 lb. Novatech load cell introduced between the cap and gear. The horizontal displacement and rotation of the cap

were measured by using two LVDT's fixed as shown in Fig. 7, to a firm support on the bucket frame.

The response of the load cell, displacement transducers and strain gauges were monitored via slip rings by a Vishay-Ellis 220 recording system which is interfaced to a Commodore CBM Model 8032 computer. The processed output is obtained directly on a printer.

Results and Discussion

All tests were carried out at a speed of 206.68 rpm of the centrifuge corresponding to an acceleration of 50 g. Thus, the model pile used in this investigation represents a prototype steel pile of 1.23 m diameter, 15.2 mm thickness embedded in sand to a depth of 9 m below ground level.

Lateral load was applied in suitable increments and the corresponding displacements and strain gauge readings were recorded. Loading was continued until the head deflections reached values of about 10 per cent pile diameter i.e. about 2.5 mm. Similar observations were made during unloading. No permanent deformation was noticed in the pile.

The deflection and rotation at the load point are shown in Fig. 8. Similar readings were obtained in the repeat tests. The load deflection curve exhibit three parts : an initial linear variation upto about 8 mm deflection corresponding to about 0.6 per cent a curvilinear portion upto about

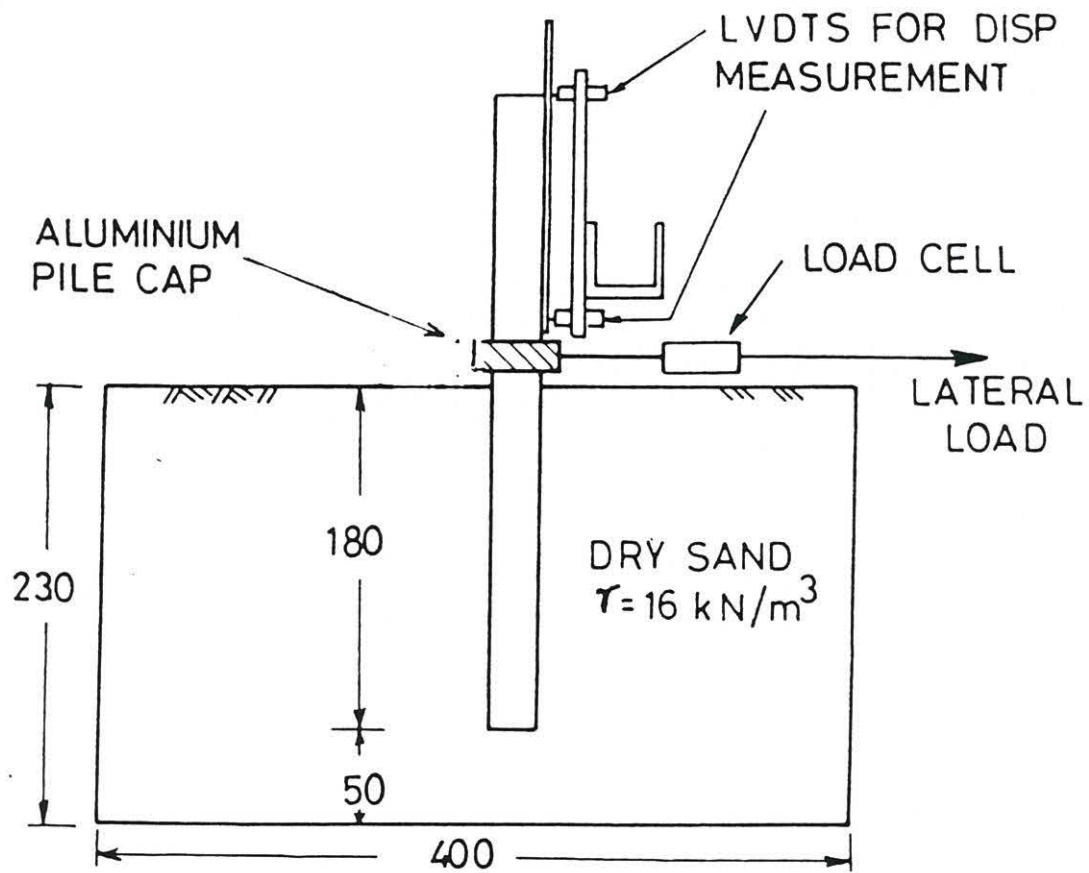

Fig.7 Experimental Set-up

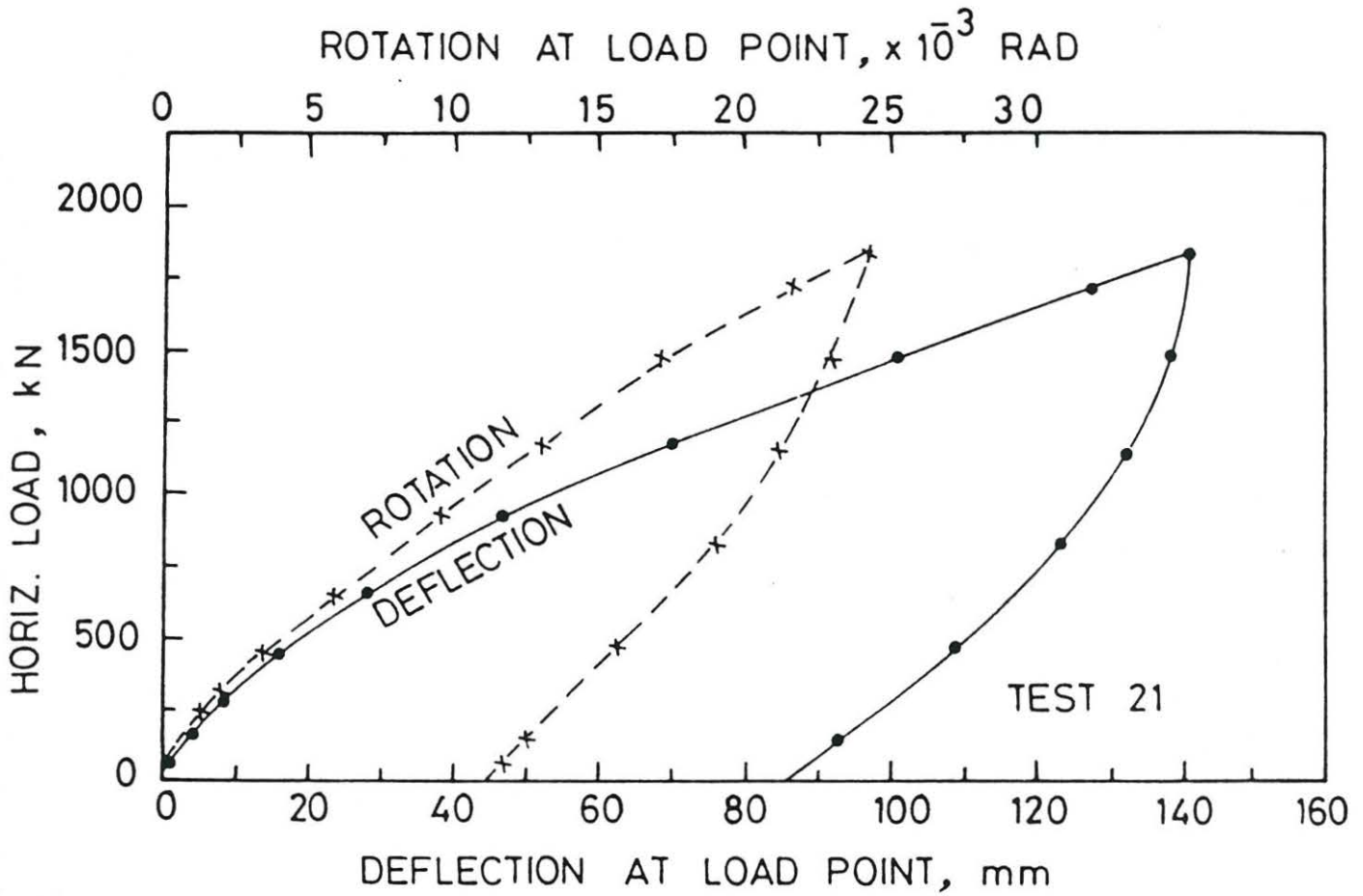

Fig.8 Load-Deflection Diagram

50 mm deflection corresponding to nearly four per cent pile diameter and a third segment which continues to be linear even upto 120 mm deflection corresponding to ten per cent pile diameter. A zone of disturbed soil (presumably failed) soil was visually observed at ground level in the immediate vicinity around the pile. The rotation of the cap also shows similar trend except that the curvilinear part occurs over a smaller range of deflection.

By back-analysis the rate of increase of horizontal subgrade reaction n_h was determined by matching the deflections at levels corresponding to one half and one per cent pile diameter with the help of coefficients developed by Reese and Matlock (1956). The corresponding n_h values worked out to 25676 kN/m^3 and 19929 kN/m^3 . The pile length to characteristic length ratios L/T at these deflections were 3.73 and 3.55 respectively. It may be noted that these values are only slightly smaller than the lower limit for long flexible piles.

The results were also back-analysed using the elastic-half space model in which the elastic modulus is proportional to depth and pile is considered to be flexible. The proportionality constant m for elastic modulus was found to have values 9246 kN/m^3 and 6987 kN/m^3 for 0.5 and 1.0 per cent deflections at the ground level. It may be seen that even within the small deflection range of one per cent, there is a large variation in the model parameters n_h and m . This indicates that linear theories have only a limited applicability in the

prediction of pile behaviour.

The bending moment distributions along the pile length computed by both the approaches are shown in Fig.9 along with the experimental values. Both the distributions agree reasonably well with the observed values in the upper half of the pile while there is some difference in the lower half. The estimates of maximum bending moment and the corresponding depths are also in reasonable agreement with the experiment.

The above analysis shows that the choice of model parameters is of importance for prediction of pile behaviour by the subgrade reaction as well as continuum models. In this respect the subgrade reaction theory is less helpful for design purposes since the n_h parameter is not unambiguously related to basic soil properties.

4. Conclusions

Dimensionless factors are presented in a convenient form for analysing flexible piles embedded in elastic half-space in which the modulus of elasticity is constant or proportional to depth.

The centrifuge experimental results show that with a judicious choice of appropriate parameters the behaviour of single piles can be predicted fairly closely at deflections less than one half per cent pile diameter. At large deflection levels the non-linearity of soils becomes increasingly important.

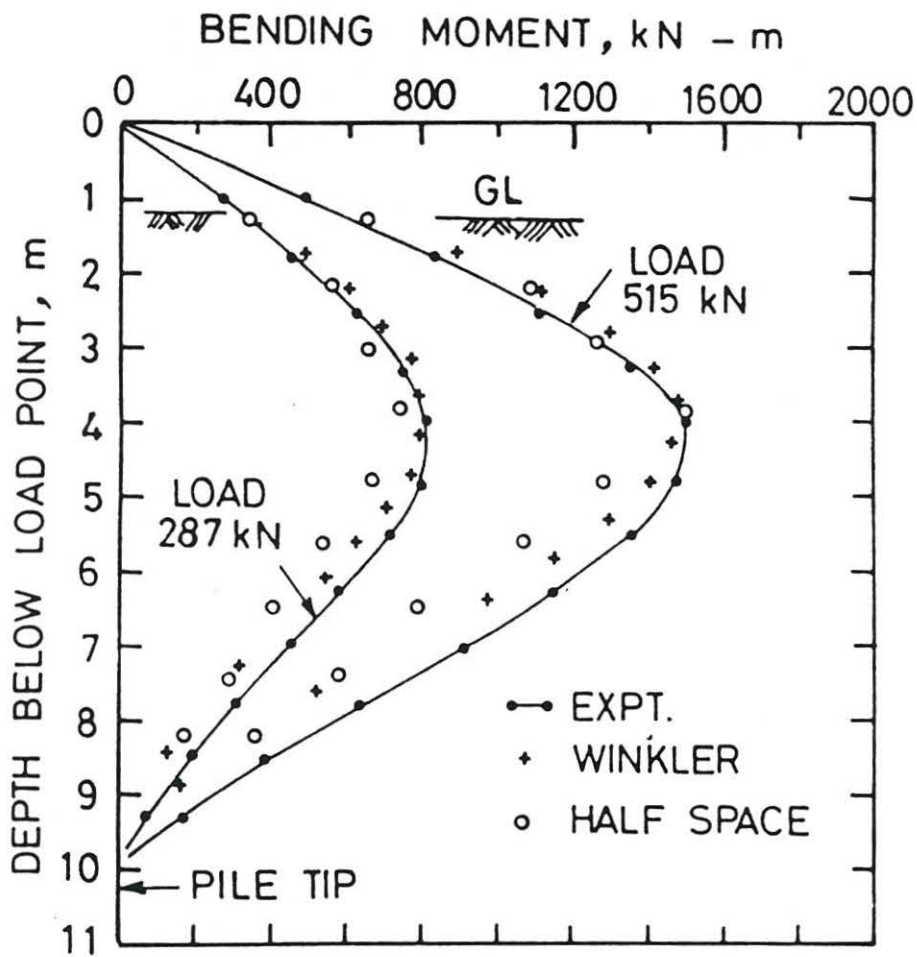

Fig.9 Bending Moment Distribution

References

- Banerjee, P.K. and Davies, T.G. (1978). The behaviour of axially and laterally loaded single piles embedded in nonhomogeneous soils. *Geotechnique* (28), 3, 309-326.
- Chandrasekaran, V.S. and King, G.J.W. (1982). Laterally loaded piles : Finite Element analysis and pile centrifugal model studies. Report submitted to the University of Liverpool, U.K.
- Davisson, M.T. and Gill, H.L. (1963). Laterally loaded piles in a layered soil system. *J. Soil Mech. and Found. Div. ASCE* (89), SM3, 66-94.
- Davisson, M.T. and Sulley, J.R. (1970). Model Study of laterally loaded piles. *J. Soil Mech. and Found. Div. ASCE* (96), SM5, 1605-1627.
- King, G.J.W., Dickin, E.A. and Lyndon, A. (1984). The development of a medium size centrifugal testing facility. *Proc. Symp. on the Application of Centrifuge Modelling to Geotechnical Design*. University of Manchester, U.K. 25-46.
- Kulkarni, K.R. and King, G.J.W. (1984). Centrifuge tests on laterally loaded pile groups in sand. Report submitted to the University of Liverpool, U.K.
- Poulos, H.G. (1971). Behaviour of laterally loaded piles : I-single piles. *J. Soil Mech. Fdn. Div., ASCE* (97), SM5, 711-731.
- Randolph, M.F. (1981). The response of flexible piles to lateral loading. *Geotechnique* (31), 2, 247-259.
- Reese, L.C. and Matlock, H. (1956). Nondimensional solutions for laterally loaded piles with soil modulus proportional to depth. *Proc. 8th Texas Conf. SMFE*, 1-41.

Reese, L.C., Cox, W.R. and Koop, F.D. (1974).
Analysis of laterally loaded piles in sand.
Sixth Annual Offshore Technology Conference (II)
OTC Paper 2080.

Schofield, A.N. (1980). Cambridge geotechnical
centrifuge operations. *Geotechnique* (30), 3, 227-268.

Terzaghi, K. (1955). Evaluation of coefficient of
subgrade reaction. *Geotechnique* (5), 4, 297-326.