

Lawrence Berkeley National Laboratory

Recent Work

Title

ELECTRICAL AND ELECTROCHEMICAL BEHAVIOUR OF FLUIDIZED BED ELECTRODES. PART II.
EFFECTIVE BED RESISTIVITIES

Permalink

<https://escholarship.org/uc/item/8905t82t>

Authors

Huh, T.
Evans, J.W.

Publication Date

1985-11-01



Lawrence Berkeley Laboratory

UNIVERSITY OF CALIFORNIA

Materials & Molecular Research Division

LAWRENCE
BERKELEY LABORATORY

MAR 6 1986

LIBRARY AND
DOCUMENTS SECTION

Submitted to the Journal of the
Electrochemical Society

ELECTRICAL AND ELECTROCHEMICAL BEHAVIOUR OF
FLUIDIZED BED ELECTRODES. PART II. EFFECTIVE
BED RESISTIVITIES

T. Huh and J.W. Evans

November 1985

TWO-WEEK LOAN COPY

*This is a Library Circulating Copy
which may be borrowed for two weeks*



ca
LBL-20841

DISCLAIMER

This document was prepared as an account of work sponsored by the United States Government. While this document is believed to contain correct information, neither the United States Government nor any agency thereof, nor the Regents of the University of California, nor any of their employees, makes any warranty, express or implied, or assumes any legal responsibility for the accuracy, completeness, or usefulness of any information, apparatus, product, or process disclosed, or represents that its use would not infringe privately owned rights. Reference herein to any specific commercial product, process, or service by its trade name, trademark, manufacturer, or otherwise, does not necessarily constitute or imply its endorsement, recommendation, or favoring by the United States Government or any agency thereof, or the Regents of the University of California. The views and opinions of authors expressed herein do not necessarily state or reflect those of the United States Government or any agency thereof or the Regents of the University of California.

Submitted to the Journal of the Electrochemical Society, January, 1986

ELECTRICAL AND ELECTROCHEMICAL
BEHAVIOUR OF FLUIDIZED BED ELECTRODES
Part II. Effective Bed Resistivities

T. Huh[†], Graduate Student
and
J. W. Evans, Professor of Metallurgy^{*}

Lawrence Berkeley Laboratory and
Department of Materials Science and Mineral Engineering
University of California
Berkeley, California 94720

Present address:

[†]Process Development Section, R & D Center, Samsung Semiconductor and
Telecommunications Company, Suwon P. O. Box 37, Kyunggi-Do, Korea

^{*}To whom correspondence should be sent.

ABSTRACT

Alternating currents were passed through fluidized beds of copper particles and zinc coated polymer particles (Sorapec particles). The sinusoidally varying potential across the bed and that across a known resistor in series with the bed were stored in a microcomputer. In the case of the copper particles the former potential showed amplitude variations thought to be due to voids ("bubbles") within the bed. These amplitude variations were dependent on bed expansion. Beds of Sorapec particles were free of these variations. Effective bed resistivities were determined and found to increase with bed expansion (rapidly in the case of copper particles).

INTRODUCTION

Part I of this two part paper has concerned itself with transients and time averaged values of particle potential, electrolyte potential and overpotential in fluidized bed electrodes. The experimental results described therein are consistent with a conductive (bipolar) mechanism wherein chains of particles are formed for brief periods of time. If a member of the chain is in contact with the current feeder then a net electrochemical reaction can be expected on the surface of each member of the chain, otherwise the chain can be expected to show bipolar behaviour. This microscopic model of a fluidized electrode can be complemented by a macroscopic view which regards a fluidized bed electrode as akin to a porous electrode; mathematical modeling based on this concept has been carried out (1,2). In the macroscopic model the electrode is regarded as two overlapping continua: the electrolyte and the "particulate phase". The (time averaged) potential distributions within each of these continua would then be dependent on their effective resistivities, as well as on the electrode kinetics of the reaction by means of which current passes from one phase to the other. Estimates of the effective resistivity of the electrolyte within the bed might be possible, for example, from the classical results of Maxwell (3) or Bruggeman (4), but estimation of the effective resistivity of the particulate phase is thought to be a much more difficult task. Limited direct measurements of particulate phase effective resistivity (1,5) have been made. One objective of the part of the investigation described in this paper was to determine the effective resistivity of beds of copper and Sorapec particles (described in Part I) and the dependence of that resistivity on bed expansion.

EXPERIMENTAL APPARATUS AND PROCEDURE

The fluidized bed used in this investigation was similar to that described in Part I except that the anode chamber was eliminated and the diaphragm replaced by a second planar current feeder. Copper current feeders were used for experiments on copper particles, graphite current feeders for Sorapec particles. By means of a sine wave generator (IG-18 Sine-Square Audio Generator, Heathkit CO.), an alternating current was passed through the bed, as well as through a resistor of 8.7 ohms (see Fig. 1). Potential differences across the known resistor and across the bed were simultaneously fed into the storage oscilloscope connected to a microcomputer (see Part I for details). Time averaged amplitudes (V_k and V_b) of these sine waves, as well as the time averaged phase angle between them (θ) were calculated by the microcomputer.

Electrolytes were prepared by adding sulfuric acid (Reagent Grade, Mallinckrodt) or potassium hydroxide (ditto) to distilled water in known amounts. The electrolyte reservoir and pump (not shown in Fig. 1) were identical with those used for the catholyte in Part I. The conductivity of the electrolyte was determined in each case using a Leeds and Northrup conductivity bridge (model 4939). Particles were prepared as in Part I prior to experimentation.

RESULTS AND DISCUSSION

Fig. 2 shows sinusoidal potential fluctuations across the known resistor (a) and across the fluidized bed of copper particles (b - f) at various bed expansions. The measurements were carried out using a sulfuric acid electrolyte of resistivity $100 \Omega\text{cm}$ and a frequency of 10 Hz. The differing vertical scales (e and f) should be noted, as should the variation in the amplitude of the sine wave (particularly evident in d and e).

The results may be explained in terms of the particle free regions ("bubbles") which were demonstrated in Part I to be responsible for the "flicker" noise of the particle potential transients. Such bubbles can be expected to greatly increase the effective resistivity of the particulate phase. At low expansion (f) the bubbles form only a small part of the bed volume and the amplitude of the sinusoidal potential across the bed is small and little affected by bubbles. At higher bed expansions (e and d) the bubbles become significant and major increases in the amplitude of the potential occur as the bubbles pass through the bed. At yet higher bed expansion (c) the bed is constantly disrupted by bubbles and the high bed resistance shows some variation that may be due to the stochastic variation of the volume of bubbles in the bed. The highest expansion (33%, b) is above that normally used in fluidized bed electrodes. It is conjectured that, at this high bed expansion, most of the alternating current is carried by the electrolyte, rather than the particulate phase and therefore the amplitude of the sine wave is nearly constant.

In Part I the particle potential transients for beds of Sorapec particles were explained in terms of the relative freedom of such beds from bubbling. This explanation was consistent with the bed behaviour diagram of Davidson and Harrison (6) and with visual observation of the beds. Fig. 3 depicts the sinusoidal potential variations across the known resistor and beds of Sorapec particles fluidized by a potassium hydroxide electrolyte of $100 \Omega\text{cm}$. In contrast with Fig. 2, no variation in amplitude is discernible in Fig. 3. The bed behaviour diagram of Davidson and Harrison predicts a maximum stable bubble size of approximately 4 mm for the Sorapec particles versus approximately 15 mm for the copper particles. These sizes should be compared to the bed width (4 - 5 mm current feeder to current feeder). In the case of

the copper particles the maximum bubble volume is more than an order of magnitude greater than that for the Sorapec particles and this size is comparable with the bed width. It appears therefore that a single bubble passing through the bed of copper particles should have a much greater effect than a single bubble in the bed of Sorapec particles. It is concluded that such bubbles as occur in the latter bed would have little effect on the effective resistivity; this explains the difference between Figs. 2 and 3.

The effective resistance of the bed can be calculated from

$$R_b = R_k \frac{V_b}{V_k} \cos\theta \quad (1)$$

where R_k is the resistance of the known resistor. Equation (1) assumes that any capacitance or inductance associated with the fluidized bed are in parallel with its resistance. For the geometry under consideration the effective resistivity of the bed can be calculated from

$$\rho_b = \frac{R_b A}{L} \quad (2)$$

where A is the active area of each current feeder and L is the current feeder separation. Equation (2) assumes that the macroscopic current flow is perpendicular to the current feeder and uniform, a situation which was thought to be approximately true in the apparatus used.

Fig. 4 shows the effective resistivity of a bed of copper particles, measured using electrolytes of various conductivities and at various bed expansions. Also included are the results of previous measurements using similar particles; the apparatus used in the present investigation is thought to be more precise than those used previously. The vertical bars on some data points represent the standard deviation of repeated measurements (each one sampling the bed for two seconds) and the stochastic nature of the conduction

in the bed is evident. Results are for 10 Hz, preliminary experiments and a prior investigation (1) revealed little dependence of the results on frequency. At the highest bed expansion the results show sensitivity to the electrolyte conductivity; at these bed expansions a significant part of the current was carried by the electrolyte and the measured resistivity is not that of the particulate phase. While the data are scattered, an overall trend is evident. As the bed is expanded the effective resistivity increases sharply. Except at the highest bed expansions the measured resistivities are well below the electrolyte resistivity for the data in Fig. 4, indicating that the major portion of the current is carried by the particulate phase. The considerable increase in bed resistivity with expansion is therefore due to a marked increase in particulate phase effective resistivity. This marked increase may be due to an increased bubble fraction in the bed. It is generally thought (7) that in bubbling beds the increase in bed volume with expansion of the bed corresponds to increased bubble volume.

Fig. 5 shows the measured resistivity of the bed of Sorapec particles at various bed expansions. The lowest curve is for an electrolyte of low resistivity and, except at low bed expansion, most of the current would be carried by the electrolyte. Regarding the other two curves, the bed resistivities of Sorapec particles are seen to be higher than those of copper particles but to increase only slightly with increasing bed expansion. A possible explanation for the former may lie in the lower electrical conductivity of zinc and the nature of the surfaces of the two particles. Although both particles appeared smooth to the naked eye, the Sorapec particles were found to have rougher surfaces than the copper particles when examined in the scanning electron microscope (8). The relatively small increase in resistivity with bed expansion for the Sorapec particles may again

be due to the relative freedom of such beds from bubbling.

CONCLUDING REMARKS

The experimental results presented in this two part paper suggest the following description of electrical and electrochemical phenomena in fluidized bed electrodes. Charge transport within the bed is both through the electrolyte and through "chains" of particles in electrical contact. The chains have only a fleeting existence as they are broken and reformed by the movement of particles in the bed. For a chain with a member in contact with the current feeder, the whole chain will approximate the current feeder potential and will, for example, be cathodic if the current feeder potential is cathodic. For a chain not in contact with the current feeder, bipolar behaviour should result. Fluctuations of potential with time and variation of time averaged potential with position therefore occur, as will both temporal and spacial variations in the rates of electrochemical reactions. These variations will be affected by the hydrodynamics of the fluidized bed and the stochastic nature of particle collisions.

In the case of dense particles (e.g. particles that are wholly metallic) one particular feature of bed hydrodynamics, namely particle free regions ("bubbles"), appears especially significant. Such bubbles have a major effect on electrolyte and particulate potentials and on the effective resistance of the particulate phase. The bubbles coalesce as they move up through the bed, in this investigation approaching dimensions comparable to the bed width, and their effective is more noticeable higher in the bed. The effects of bubbles also increase with bed expansion since they are absent at minimum fluidization velocity and increase as the electrolyte velocity (and bed expansion) are increased beyond this point.

ACKNOWLEDGMENT

Both parts of this investigation were supported by the Assistant Secretary for Conservation and Renewable Energy, Office of Energy Systems Research, Energy Storage Division of the U. S. Department of Energy under contract number DE-AC03-76SF00098.

REFERENCES

- 1 Sabacky, B. J. and J. W. Evans (1977), "The Electrical Conductivity of Fluidized Bed Electrodes - Its Significance and Some Experimental Measurements", Met. Trans. 8B, p. 5.
- 2 Sabacky, B. J. and J. W. Evans (1979), "Electrodeposition of Metals in Fluidized Bed Electrodes: Part I. Mathematical Model", J. Electrochem. Soc. 126, p. 1176.
- 3 Maxwell, J. C. (1892), "A treatise on Electricity and Magnetism", 2d ed., Clarendon Press, Oxford, p. 435-445.
- 4 Bruggemann, D. A. G. (1935), "Berechnung verschiedener physikalischer konstanten von heterogenen substanzen", Ann. Physik. 24, p. 636.
- 5 Ziegler, D. P., M. S. Thesis, University of California, Berkeley (1980).
- 6 Davidson, J. F. and D. Harrison, "Fluidized Particles", Cambridge University Press, New York (1963).
- 7 Kunni, D. and O. Levenspiel, "Fluidization Engineering", John Wiley and Sons, New York (1969).
- 8 Huh, T., Ph.D. Dissertation, University of California, Berkeley (1985).

FIGURE CAPTIONS

- 1 Schematic diagram of the apparatus used in this investigation.
- 2 Sinusoidal potential drop measured across:
(a) known resistor, (b) fluidized bed of copper particles at 33% bed expansion, (c) 25% expansion, (d) 20%, (e) 15%, (f) 10%.
- 3 Sinusoidal potential drop measured across:
(a) known resistor, (b) fluidized bed of Sorapec particles at 40% bed expansion, (c) 25%, (d) 10%.
- 4 Variation of effective resistivity of fluidized beds of copper particles with bed expansion at various electrolyte conductivities. Filled symbols are from prior investigations; ■ = ref. 1, ▲ = ref. 5.
- 5 Variation of effective resistivity of fluidized beds of Sorapec particles with bed expansion at various electrolyte conductivities.

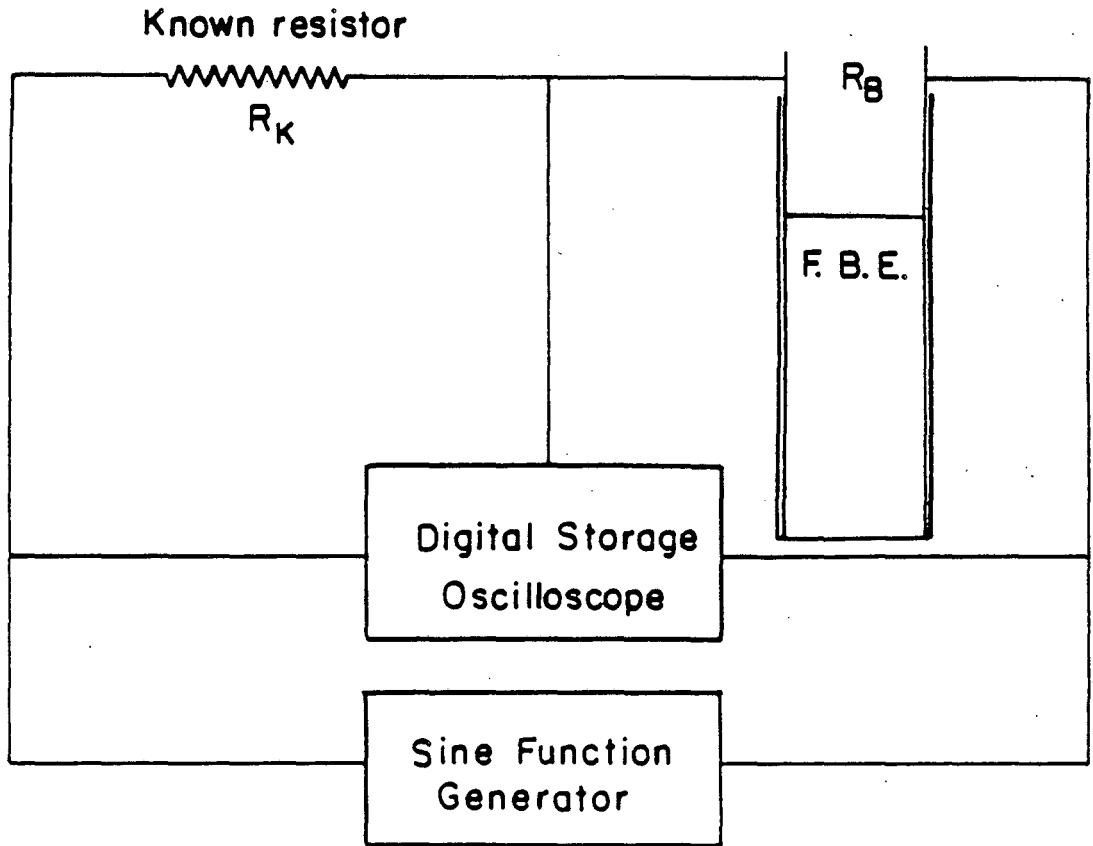

XBL 8510-4211

Fig. 1

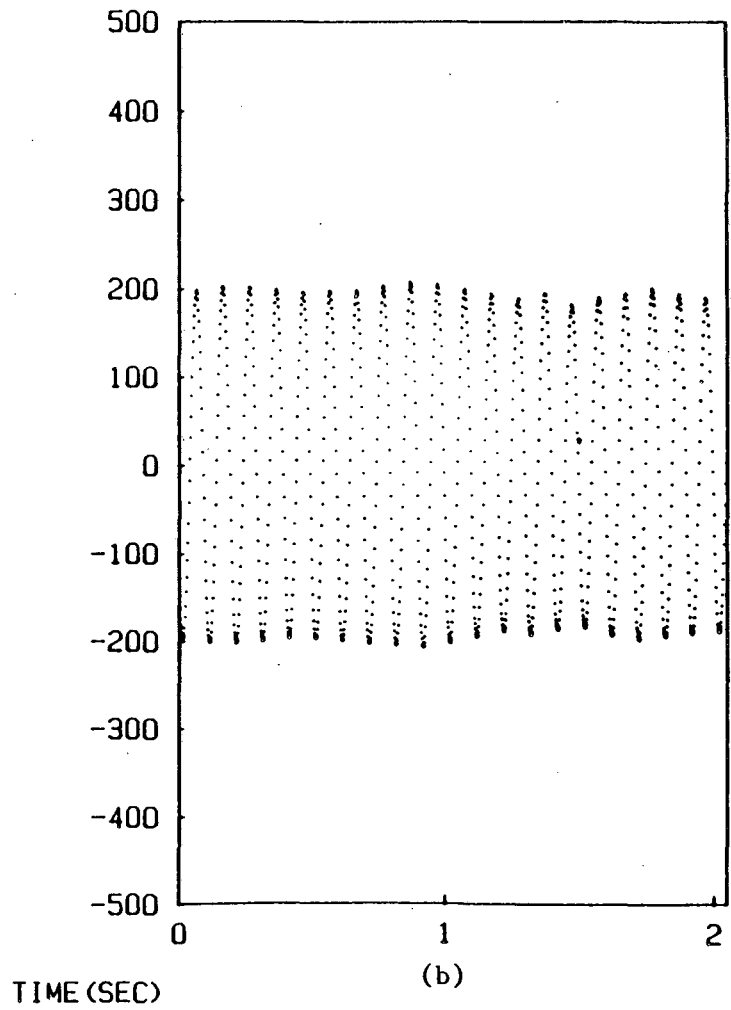
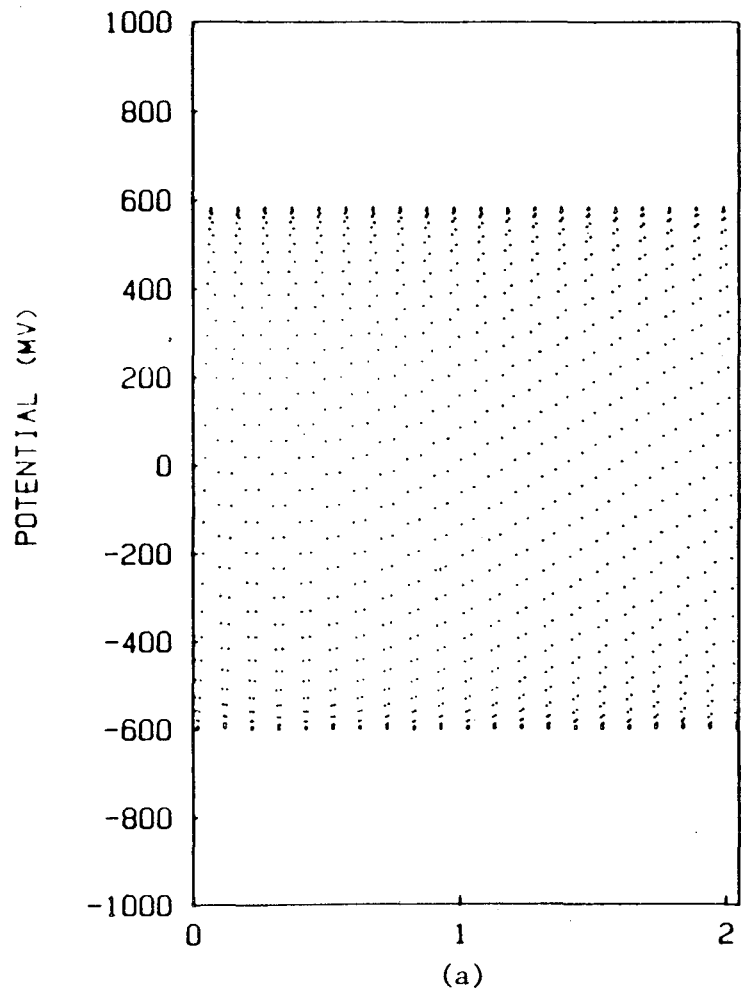
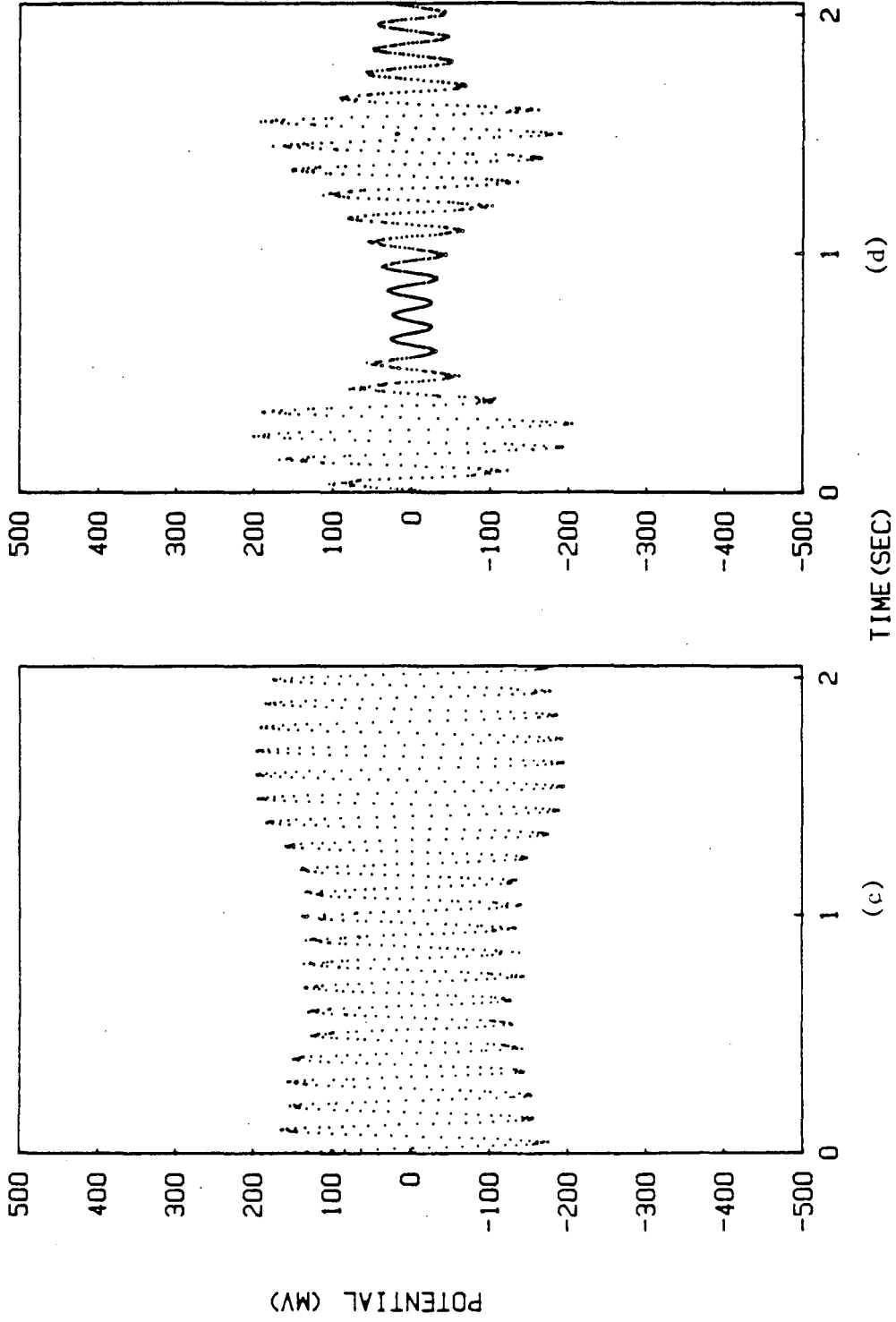

Fig. 2

XBL 8510-4210



XBL 8510-4209

Fig. 2

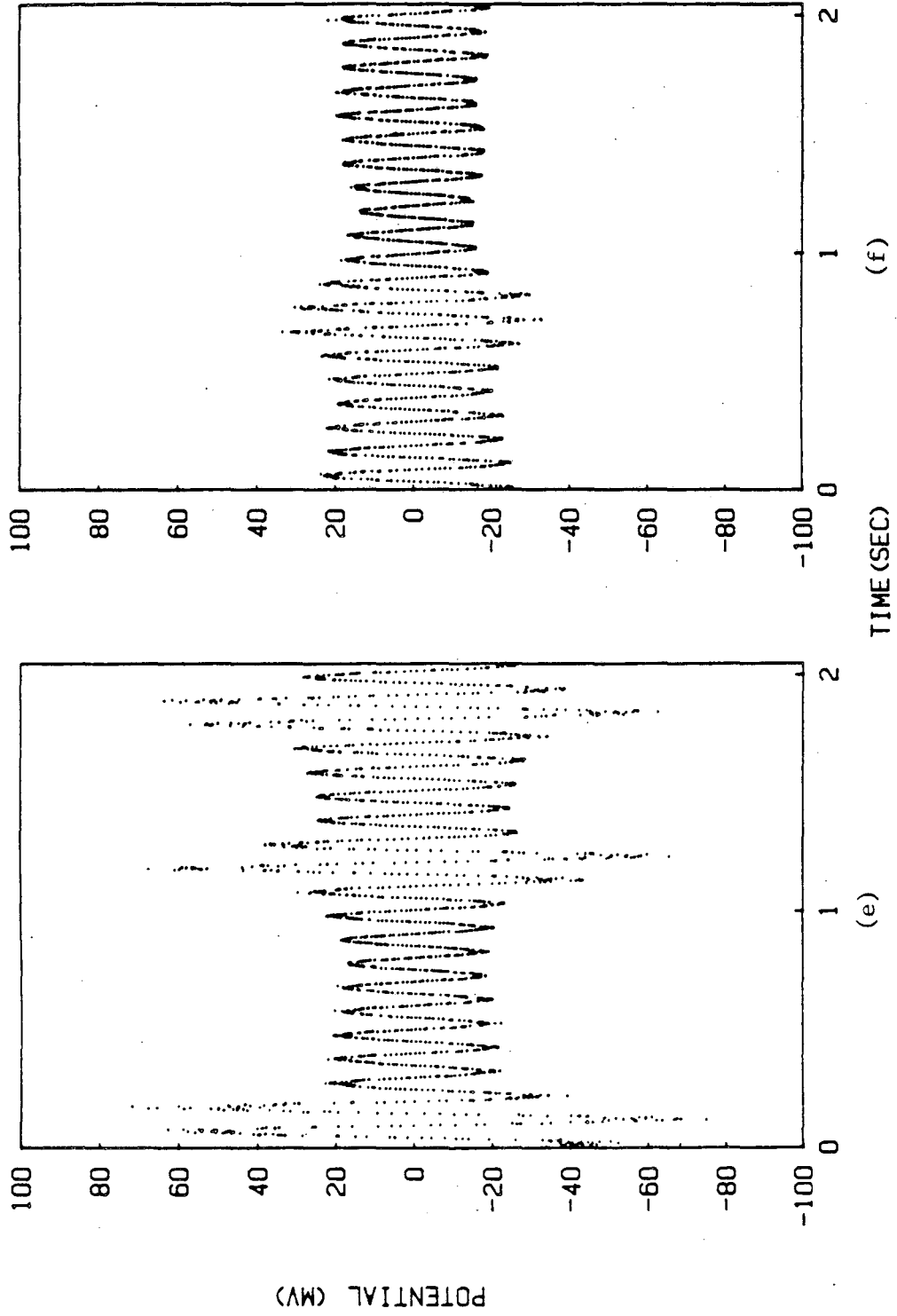

XBL 8510-4208

Fig. 2

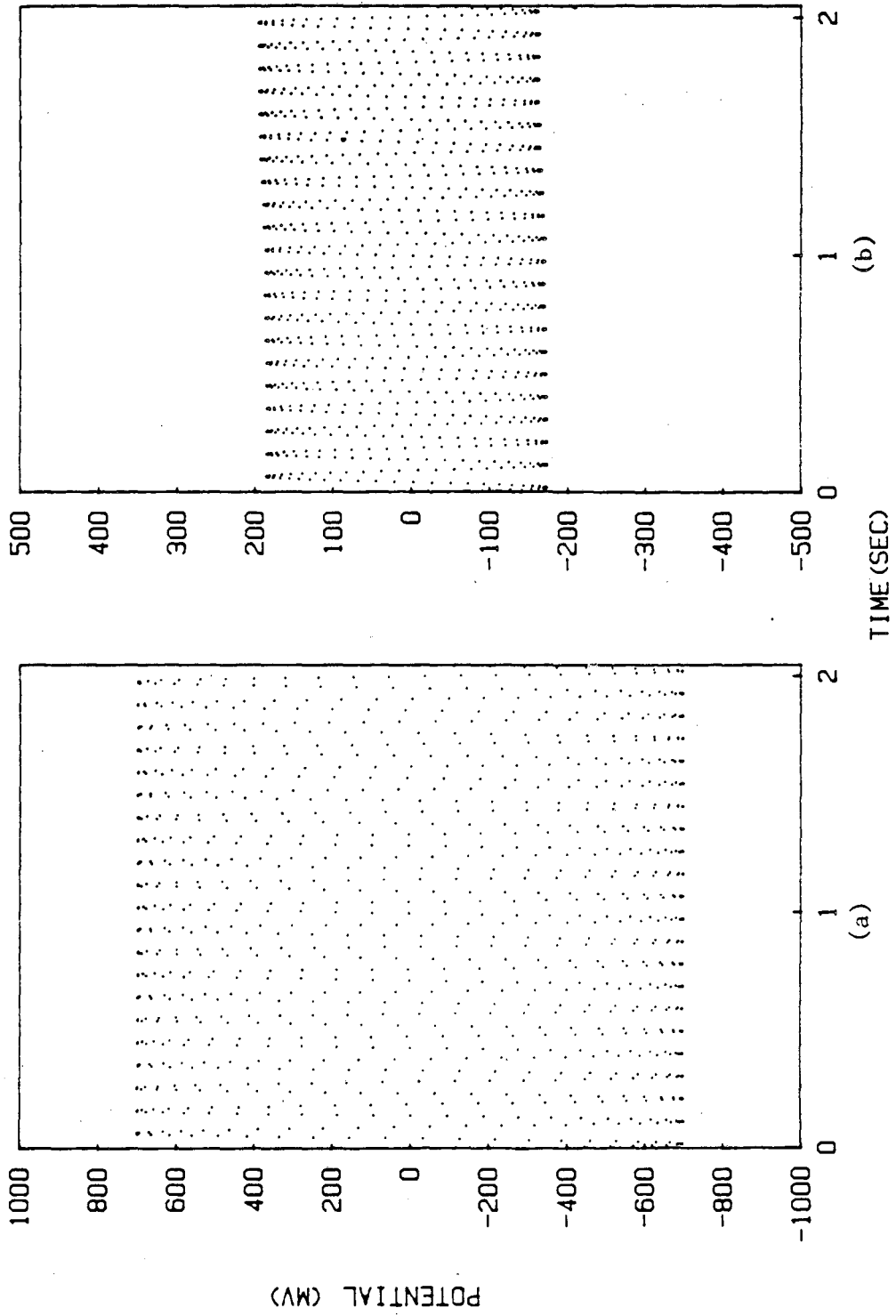
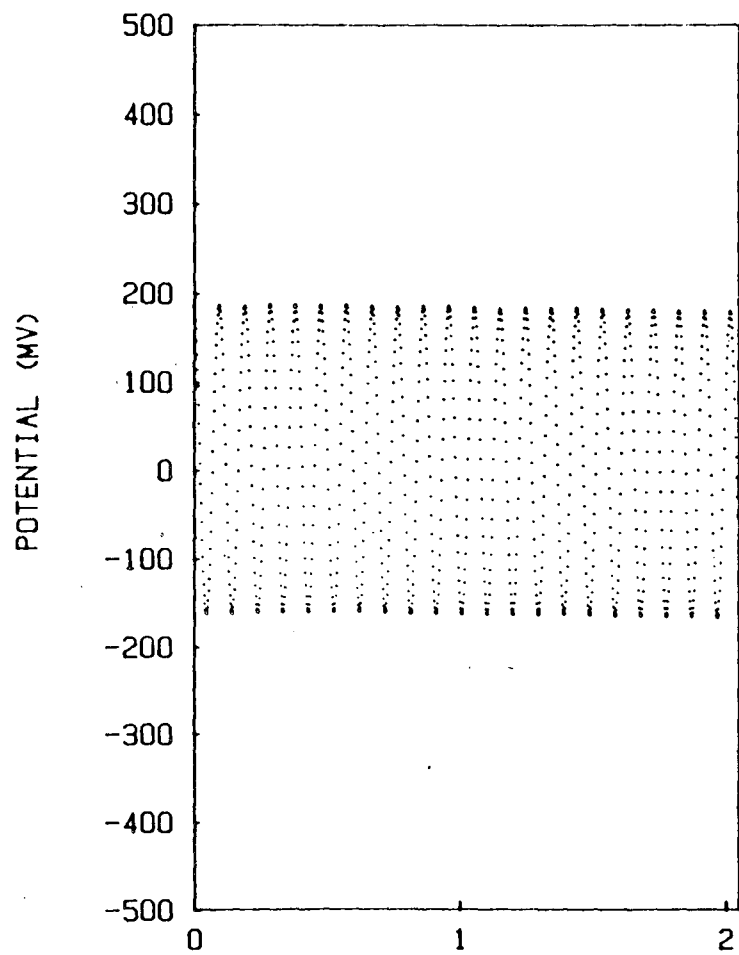
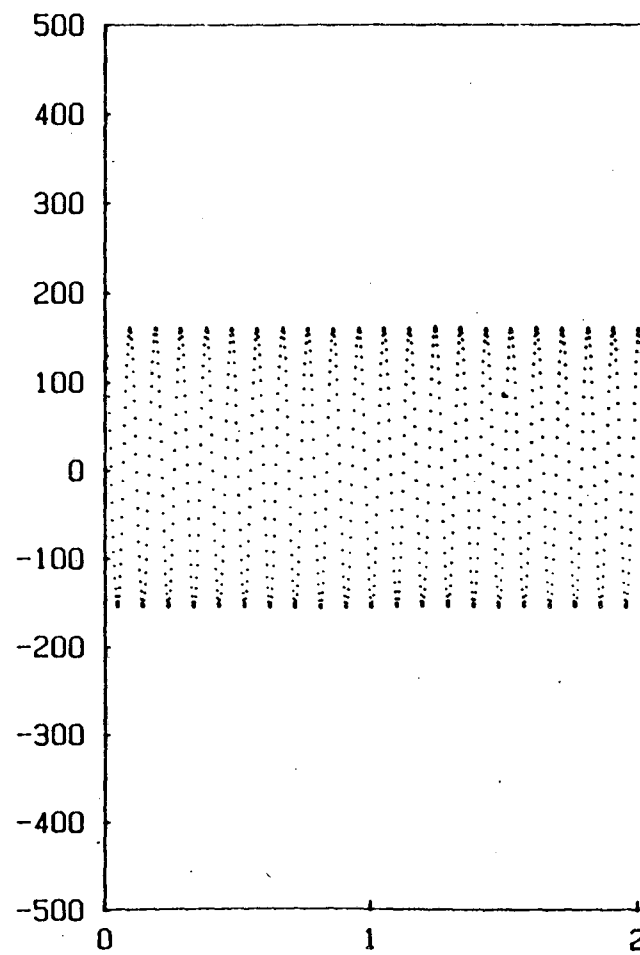

Fig. 3

XBL 8510-4207



(c)



(d)

TIME (SEC)

XBL 8510-4206

Fig. 3

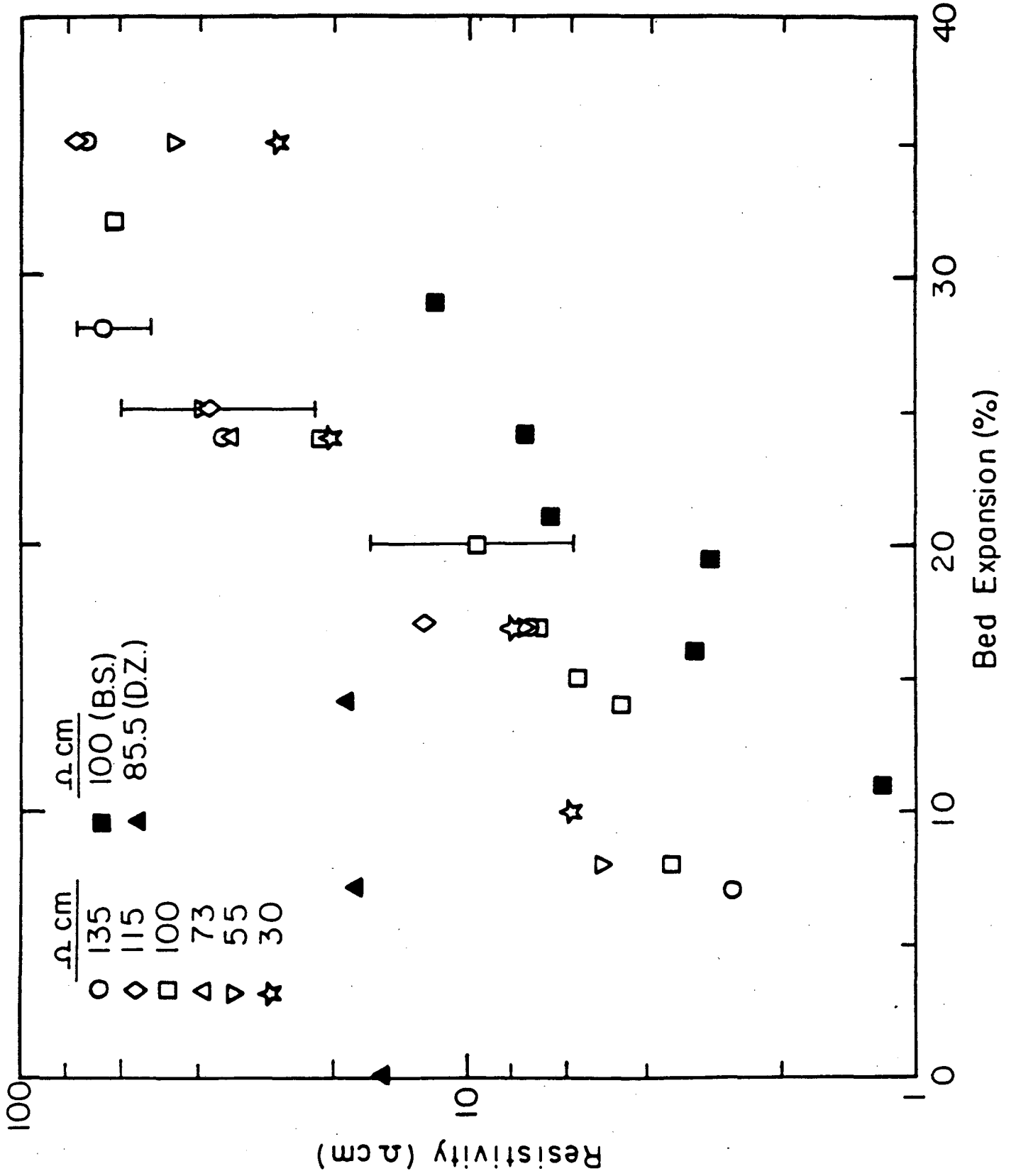

Fig. 4

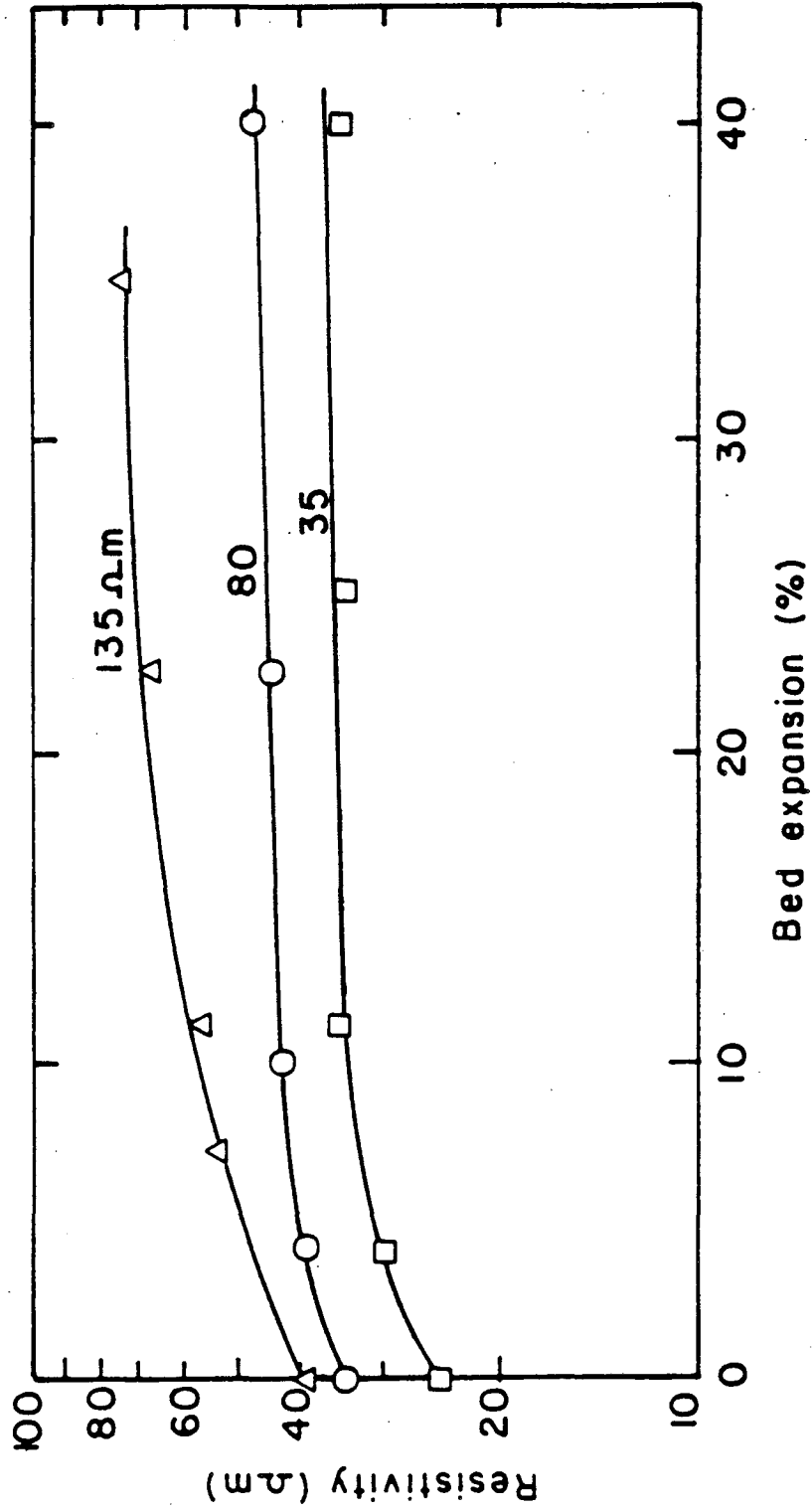

FIG. 5

This report was done with support from the Department of Energy. Any conclusions or opinions expressed in this report represent solely those of the author(s) and not necessarily those of The Regents of the University of California, the Lawrence Berkeley Laboratory or the Department of Energy.

Reference to a company or product name does not imply approval or recommendation of the product by the University of California or the U.S. Department of Energy to the exclusion of others that may be suitable.

*LAWRENCE BERKELEY LABORATORY
TECHNICAL INFORMATION DEPARTMENT
UNIVERSITY OF CALIFORNIA
BERKELEY, CALIFORNIA 94720*