

UC Berkeley

Research Reports

Title

The Potential of Using Transit Infrastructure for Air Freight Movement: A Case Study in the Bay Area

Permalink

<https://escholarship.org/uc/item/8457k7w3>

Authors

Wang, Rui
Lu, Xiao-Yun
Sivakumaran, Karthik

Publication Date

2010-10-01

CALIFORNIA PATH PROGRAM
INSTITUTE OF TRANSPORTATION STUDIES
UNIVERSITY OF CALIFORNIA, BERKELEY

The Potential of Using Transit Infrastructure for Air Freight Movement: A Case Study in the Bay Area

Rui Wang, Xiao-Yun Lu, and Karthik Sivakumaran

**California PATH Research Report
UCB-ITS-PRR-2010-38**

This work was performed as part of the California PATH Program of the University of California, in cooperation with the State of California Business, Transportation, and Housing Agency, Department of Transportation, and the United States Department of Transportation, Federal Highway Administration.

The contents of this report reflect the views of the authors who are responsible for the facts and the accuracy of the data presented herein. The contents do not necessarily reflect the official views or policies of the State of California. This report does not constitute a standard, specification, or regulation.

Phase I Report for Caltrans Contract #65A0329

October 2010

ISSN 1055-1425

The Potential of Using Transit Infrastructure for Air Freight Movement: A Case Study in the Bay Area

Phase I Report

Project Sponsored by Caltrans CT #65A0329

Authors

California PATH, Institute of Transportation Studies, U. C. Berkeley:

Rui Wang, Xiao-Yun Lu, and Karthik Sivakumaran

March 31, 2010

Revised on Sept. 26, 2010

Acknowledgements

This work was performed as part of the California PATH Program of the University of California in cooperation with the State of California Business, Transportation and Housing Agency, Department of Transportation (CT #65A0329). The contents of this report reflect the views of the authors who are responsible for the facts and the accuracy of the data presented herein. The contents do not necessarily reflect the official views or policies of the State of California. This paper does not constitute a standard, specification, or regulation.

Active Participants of the Project include: BART engineers Richard Lu and Stephen Peery; Faisal Zaman, Run Zhou, and Michael Graham of FedEx; Caltrans DRI project manager Matt Hanson.

The strong support from Tom Messer and Michele Fell in Caltrans Goods Movement, and Colette Armao in Caltrans Aeronautics, are gratefully acknowledged.

STATE OF CALIFORNIA DEPARTMENT OF TRANSPORTATION
TECHNICAL REPORT DOCUMENTATION PAGE
 TR0003 (REV. 10/98)

1. REPORT NUMBER CA10-0918	2. GOVERNMENT ASSOCIATION NUMBER	3. RECIPIENT'S CATALOG NUMBER
4. TITLE AND SUBTITLE THE POTENTIAL OF USING TRANSIT INFRASTRUCTURE FOR AIR FREIGHT MOVEMENT: A CASE STUDY IN THE BAY AREA		5. REPORT DATE October 2010
		6. PERFORMING ORGANIZATION CODE
7. AUTHOR(S) Rui Wang (GSR), Dr. Xiao-Yun Lu, and Karthik Sivakumaran (GSR)		8. PERFORMING ORGANIZATION REPORT NO. UCB-ITS-PRR-2010-38
9. PERFORMING ORGANIZATION NAME AND ADDRESS Institute of Transportation Studies University of California, Irvine Irvine, CA 92697-3600		10. WORK UNIT NUMBER
		11. CONTRACT OR GRANT NUMBER 65A0329
12. SPONSORING AGENCY AND ADDRESS California Department of Transportation Division of Research and Innovation, MS-83 1227 O Street; Sacramento CA 95814		13. TYPE OF REPORT AND PERIOD COVERED Final Report February 1 2009- December 15 2009
		14. SPONSORING AGENCY CODE
15. SUPPLEMENTAL NOTES None		
16. ABSTRACT <p>This report examines the impact and feasibility of using urban railway system for freight movement. In particular, using the Bay Area Rapid Transit (BART) system for FedEx Express air cargo movement is analyzed as a case study. Based on the framework constructed in the study of last phase, social impact (externalities), reliability, and infrastructure feasibility are considered. The social cost related to emission, energy consumption/efficiency, impact on road traffic and land use is considered. The reliability issue is examined from two aspects: transportation delay, and emergency situation handling. The infrastructure feasibility is analyzed based on the proximity and accessibility of BART yards/shops/stations and FedEx collection/distribution centers, the air freight container size, and the conceptual designs of dedicated BART freight car and transshipment equipment.</p>		
17. KEY WORDS feasibility study, mixed passenger goods movement, air freight, BART (Bay Area Rapid Transit), urban rail, reliability, emission, infrastructure feasibility		18. DISTRIBUTION STATEMENT No restrictions. This document is available to the public through the National Technical Information Service, Springfield, VA 22161
19. SECURITY CLASSIFICATION (of this report) Unclassified	20. NUMBER OF PAGES 58	21. PRICE N/A

Reproduction of completed page authorized

DISCLAIMER STATEMENT

This document is disseminated in the interest of information exchange. The contents of this report reflect the views of the authors who are responsible for the facts and accuracy of the data presented herein. The contents do not necessarily reflect the official views or policies of the State of California or the Federal Highway Administration. This publication does not constitute a standard, specification or regulation. This report does not constitute an endorsement by the Department of any product described herein.

For individuals with sensory disabilities, this document is available in Braille, large print, audiocassette, or compact disk. To obtain a copy of this document in one of these alternate formats, please contact: the Division of Research and Innovation, MS-83, California Department of Transportation, P.O. Box 942873, Sacramento, CA 94273-0001.

Keywords: feasibility study, mixed passenger goods movement, air freight, BART (Bay Area Rapid Transit), urban rail, reliability, emission, infrastructure feasibility

Abstract

This report examines the impact and feasibility of using urban railway system for freight movement. In particular, using the Bay Area Rapid Transit (BART) system for FedEx Express air cargo movement is analyzed as a case study. Based on the framework constructed in the study of last phase, social impact (externalities), reliability, and infrastructure feasibility are considered. The social cost related to emission, energy consumption/efficiency, impact on road traffic and land use is considered. The reliability issue is examined from two aspects: transportation delay, and emergency situation handling. The infrastructure feasibility is analyzed based on the proximity and accessibility of BART yards/shops/stations and FedEx collection/distribution centers, the air freight container size, and the conceptual designs of dedicated BART freight car and transshipment equipment.

Table of Contents

	Page
Abstract	2
Acknowledgements	3
Table of Contents	4
List of Figures and Tables	5
Executive Summary	7
Chapter 1 Introduction.....	10
Chapter 2 Literature Review	12
Chapter 3 Review of Economic Study	15
Chapter 4 Reliability for Air Freight Movement.....	24
4.1 Transportation Delay	25
4.2 Emergency Situation Handling.....	26
Chapter 5 Preliminary Social Impact Analysis.....	27
5.1 Road Traffic Impact.....	27
5.2 Energy Efficiency	29
5.3 Environmental Impact.....	30
5.4 Further Remarks	36
Chapter 6 Infrastructure Feasibility.....	38
6.1 Proximity of BART Access Point and FedEx Distribution Centers	38
6.2 BART Cars for Dedicated Freight Movement.....	40
6.3 Transshipment.....	45
6.4 Summary.....	50
Chapter 7 Further Thoughts for Next Step	51
Reference	56

List of Tables and Figures

Tables

Table 3-1. Origin-Destination Demand Matrix.....	16
Table 3-2. Summary of the Scenarios Considered.....	17
Table 5-1. Energy Resources and Efficiency Factors	29
Table 5-2. Pollutant Emission Factor	33
Table 5-3. Emission Unite Cost Factor	34
Table 6-1. FedEx Standard Air Freight Containers.....	45
Table 6-2. Cost (in \$) of dedicated freight lift for accessing BART aerial station(s)	47
Table 6-3. Required Modification.....	47
Table 6-4. Transshipment Capital Cost.....	48
Table 6-5. Transshipment Time.....	49

Figures

Figure 3-1. BART System Map	15
Figure 3-2. Mixed-goods BART network in Alternatives A1 and A2	18
Figure 3-3. Mixed-goods BART network in Alternatives B1 and B2	18
Figure 3-4. Truck VMT for Different Alternatives	19
Figure 3-5. CO2 Emission for Different Alternatives.....	20
Figure 3-6. FedEx Cost for Different Alternatives	20
Figure 3-7. BART Cost for Different Alternatives	21
Figure 3-8. Total Cost for BART and FedEx for Different Alternatives.....	21
Figure 3-9. Minimum Subsidy Required for Different Alternatives.....	22
Figure 3-10. Number of Accidents for Truck Operations to FedEx for Different Alternatives.....	22
Figure 3-11. Accident Cost for Truck Operations to FedEx for Different Alternatives	23
Figure 3-12 Maintenance Cost to FedEx for Different Alternatives.....	23
Figure 5-1. Emission Cost Forecast.....	36

Figure 6-1. BART stations, shops and tail track and FedEx Collection/Distribution Centers.....39

Figure 6-2. USPS Containers used by FedEx, small enough to fit in BART car.....40

Figure 6-3. Dedicated BART Freight Car Design.....41

Figure 6-4. Car Quality Comparison43

Figure 6-5. FedEx Standard Air Freight Movement Containers.....45

Figure 6-6. Roller Mat or Ball Bearing for Container Transshipment.....48

Figure 6-7. Truck-train Transshipment Solution 1: Directly Pushing.....49

Figure 6-8. Side Loading Using Flexible Crane Mounted on Rail on the Platform50

Figure 6-9. Side Loading Using a Flexible Crane on a Heavy-Duty-Vehicle51

Executive Summary

The San Francisco Bay Area has one of the most highly developed and heavily congested metropolitan corridors nationwide with still increasing demand for both passenger and freight transport. It is also a main entrance to the United States for the huge Asia market, and thus critical for the United States to play a leading role in the global economy. On one hand, traffic congestion in the main corridors through the Bay Area is severe and is becoming worse with the rapid increase of population and the development of the local economy, in which a substantial impact is created by truck-related activities such as the ever increasing air freight business (performed by companies such as Federal Express and UPS). On the other hand, the San Francisco Bay Area Rapid Transit District (BART) operates a regional environmentally-green transit system has excess capacity during non-commute periods and during the commute on some lines in some reverse-commute direction. On average, BART only uses 30% of its capacity for daily passenger movement with the other 70% unused. Here the capacity calculated is based on current full operation with 15 minutes headway and ten-car consist. If, however, BART system adopts modern technologies in sensor, communication system, and control system, the operation headway could be greatly reduced and the capacity could be doubled, or even tripled. (2) it is completely grade separated from general traffic, making its service free of cross-traffic delays, accidents, etc., and its travel times can be competitive to the automobile during congested periods; (3) it operates at higher frequencies than other train systems and has a high on-time reliability of nearly 95%; (4) it operates a system that places a high regard for safety; (5) it is electrically powered and emits no air pollution. For the interests of traveling public as well as local, regional, and state government, it would reduce truck activity and its corresponding negative impacts on traffic, road maintenance, environment, safety and land use.

If the BART system is to be used by the air-freight delivery service providers, BART could in theory provide reliable service to integrated freight carriers to meet their limited-time window delivery needs. This could lead to additional revenue generation for BART. Using BART for air freight movement as a model for combined goods and passenger movement can be generalized to other critical corridors nationwide to effectively relieve

corridor congestion problem. Improving movement through these critical metropolitan corridors could yield significant benefits in terms of reduced travel time, delays, increased reliability, and predictability of freight movement. Another benefit is increased utilization of heavily invested existing transportation infrastructure through public-private partnerships.

This work is a continuation of the preceding phase of the project sponsored by UCTC and Caltrans. Based upon the planned transportation network and schedule, this report focuses on the reliability, social cost and feasibility of the use of the Bay Area Rapid Transit (BART) system for freight movement from/to Oakland International Airport (OAK). We started from air freight simply because it has similar safety and security standard as the passenger movement. However, some other products such as high-tech manufacturer products and agricultural products can be easily made to satisfy those standards and therefore could be accounted as potential demand.

The proposal is examined both quantitatively and qualitatively, including the benefits and costs to FedEx (the carrier), the BART (urban railway), and the public. The reliability of service is a predominant interest of the integrated air freight carriers, which together with the social benefit are the main concern of the study in this phase.

The reliability issue is examined from two aspects: transportation delay, and emergency situation handling. Although there is no quantitative assessment for the reliability level, it has been justified that the BART system maintains one of the highest level of on-time reliability.

During the last phase of the project, the social cost (externalities) is presented roughly. In this work, more emphasis has been put on the social impact analysis, which is demonstrated from three aspects: road traffic congestion (delay, safety and land use), energy efficiency and environmental. The monetary cost of emission is calculated, showing significant cost by emission.

The infrastructure feasibility is analyzed based on the proximity of stations, the feasibility of container, and the transshipment feasibility. Potential approaches are presented and discussed, with their estimated cost. The overall budget of infrastructure modification is proven to be manageable.

The analysis presents the improvement of reliability of using the BART, the significant

social cost of using the current mode, and an operable implementation scheme. In the future, the analysis and the implementation scheme will be refined. With increasing demand, the social benefit can become even more significant. A high level operation scheme is also proposed, including the investment to facilitate the infrastructure for transshipment and the corresponding efficiency.

Chapter 1. Introduction

The rapid increase in traffic congestion in the contemporary world results in even more rapid rising in social cost. The road traffic congestion is the direct cause of many other problems such as traffic accidents, environmental pollution, global warming, and pavement wearing. Freight movement by trucking contributes the most significant part to those problems. The Bay area as densely populated is at particularly crucial position in facing such problems due to high level of traffic, container movement through the seaport (Port of Oakland), and air freight movement through the three international airport (OAK, SFO, and SJC).

Freight movement is a critical factor to the bay area economy. Beside the role of inputting/exporting from/to international market through seaport and airports, over 37 percent of Bay Area economic output is in manufacturing, freight transportation, and warehouse and distribution businesses. Trucking is the most frequently adopted mode in freight movement in those activities. As a consequence, congestion and pollution seems inevitable. Heavy duty diesel vehicle alone contributes to 30% of nitrogen oxide emission in 2005 (Metropolitan Transportation Commission, 2004; 2008a, 2008b). To mitigate those problems, it is urgent to find alternative transportation modes with less pollutant, less road traffic impact, and better characteristics such as safety and reliability, to accommodate high demand of transportation from economic activities and daily life without sacrificing the interests of Bay Area Community.

With those considerations, utilizing the unused capacity of BART system are in favor of all the interests. Besides, the introduction of freight movement in BART offers opportunity to improve the service and performance of the system itself. This is because 1) only 30% of BART's mainline is being used leaving 70% wasted. If BART adopts more developed technology, the current headway of 15 minutes can be largely reduced, giving double or even triple capacity; (2) it is completely grade separated from other modes of traffic, and hence not involved in traffic delays. During peak hour congestion, its travel times is especially competitive to the automobile; (3) its on-time reliability is over 95%, and the operating

frequency is higher than other transit systems; (4) the system places a high regard for safety, and is not affected by road accidents; (5) it is electrically powered and emits no air pollution during operation, and reduces road traffic load without generating induced demand. We start off from air freight because it has the most similar safety and security standard as the passenger movement. However, some other products such as high-tech manufacturer products and agricultural products can be easily made to satisfy those standards, and accounted as potential demand.

Traditionally, railway systems are considered as less efficient in terms of efficiency and cost comparing with truck. However, with the increasing concern of labor costs and rights, as well as the accelerating increasing social costs, trucking is losing its advantage rapidly in the coming era. If the idea presented in this paper can be extended and practiced in other urban rail lines, it may offer a solution for many of the existing urban transportation problems. However, there is a surprising lack of exploration in this direction, and this work hopes to spur future action in this regard.

The report is structured as follows: Chapter 2 is for relevant literature review. Chapter 3 examines the reliability issue associated with truck and rail, and the comparison. Chapter 4 reviews the work of the previous phase, especially the structure of the transportation network. Chapter 5 explores the concern of externality generated from trucking. The monetary value of emission is calculated, offering a more detailed idea of the cost of pollution. Chapter 6 discussed the infrastructure feasibility issue, and proposed operating schemes. The investment and time cost are estimated. Chapter 7 presents some final thoughts and future plans.

Chapter 2. Literature Review

There are not many literatures available on urban rail network for combined passenger and freight movement. Literatures on the three aspects that we will be investigating: urban intermodal transportation, road pricing (related to future truck operational cost), reliability, social impact, and infrastructure have been reviewed and presented below in some level of details for our analysis next.

In the recent year, the consideration of use rail network in freight movement is emerging, especially in the Europe. Existing literature shows arise of such concern is usually due to the congestion in urban area, the environmental issue, and the loss of accessibility.

Maes and Vsnelslander (2009) analyzed the feasibility of utilizing the rail transport as part of the supply chain in an urban logistic context in western Europe. In the study, they examined the case of Monoprix, an innovative French company, and achieved positive result from the test. Although the current cost-benefit balance for Monoprix is negative, taking into account the improving efficiency and the possible road charging scheme in France, the case can be increasingly profitable.

In the study of Nozzolo et al (2007), a methodology is presented for metropolitan freight distribution in railway in Italy. The work presents the methodology for the technical and economic feasibility analysis. Through the freight demand modeling system, the study shows that the new distribution system is consistent, but it needs public authority intervention in order to cover the gap between the extra costs supported by the users.

In terms of air freight demand data, the study conducted by Wei (2009) identifies the major data resources of California. He discussed the accuracy and consistency of these data, and further concluded that the data indicates the important role of air freight in California economy. Therefore, there should be a higher level investment for supporting the air cargo industry in California.

In the *Comparative Evaluation of Rail and Truck Efficiency on Competitive Corridors* conducted by Federal Railroad Administration (ICF International, 2009), it is demonstrated

that the rail system usually experience 2 to 5 times the efficiency of trucks. Although there is consistent effort on improving the truck efficiency, the rail system still maintains unbeatable advantage in terms of less emission generation.

Work by Bozicnik (2007) studied the Light-combi project in Sweden or Cargo Sprinter in Germany, and the Mobiler system in Switzerland. The analysis proved that success of intermodal transport can be achieved, going through certain barrier and provided that interdisciplinary support can be assured. The work also suggests that the ideal freight transport technology for small shipments and/or short- and medium distances would be a combination of a truck (high flexibility) on the rail (mass production).

Work in reliability of rail network by Vromansa et al (2006) suggests that the reliability of railway usually and only depends on time headway. The assessment of reliability is quite complicated, involving measurement of homogeneity, heterogeneity and headway. The degree of reliability increases with homogeneous service, and smaller time headway.

Delucchi (2000) suggested in his Environmental Externalities of Motor-vehicle Use in the US, that the marginal impact is increasing with the existing pollutant level. The perceivable impact includes human illness, visibility reduction, agricultural loss, etc. Although there remains considerable uncertainty in all stages for modeling the damage cost, the results enriches cost-benefit and pricing analyses from a larger extent. The estimation of external costs have been used for comparing the social costs of different transport technologies or modes, evaluating the trade-offs between different environmental impacts, and analyzing policies.

Holguin et al (2009a, 2009b) studied the road pricing issue and off-hour delivering strategy. It is optimal for the transportation system if more road users are using off-hour traveling, which requires a certain level of incentive for the road users to do so. The research has highlighted that delivery time decisions are jointly made between carriers and receivers. The carrier-receiver consistency is also a requirement. Without large amount of data, the discrete choice model can be calibrated and utilized for planning purposes. However, if the data is sufficient, the Behavioral micro-simulation (BMS) may have more advantage. The

approximation model clearly indicates that, for a given probability of receiving in off-hour, the joint market share is going to be determined primarily by the proportion of “short” tours as the probability of all receivers agreeing to off-hour deliveries geometrically decreases with tour length. On the other hand, Increase in vehicle size will increase the cost, pollution, and congestion per travel. However, it will also decrease the vehicle dispatching frequency, which will decrease the overall cost, pollution as well as congestion level. The paper deals with the analytical approach of searching for the tradeoff in between the positive and negative impact of increasing vehicle size. By converting all those factors into monetary value, the result is clearly comparable. Generally, with the increasing travel demand, a larger vehicle appears to be more optimal.

The study of Paaswell (2009) focuses on the elaboration of the potential benefit of transporting freight with rail, aiming at convincing the government and stake-holders of the importance of the mode conversion. At the same time, a site for the intermodal facility is chosen. But it should be noticed that while choosing the site, other negative impacts might arise, such as potential adverse environmental impacts, including possible effects on the resident and out-patient populations as well as possible environmental justice issues and limitations on space for the development of expanded warehouse capacity. It is also emphasized that the negative impacts a transfer yard might produce - especially regarding traffic - would be far outweighed by the negative impacts that would be associated with other new and planned nearby developments. The problem is especially severe for the case of the long, narrow, densely populated cul-de-sac that is Long Island. The result seems to be left in question.

Chapter 3. Review of Economic Study

In the last phase of the project, which focused on economic analysis based on some assumption on infrastructure of BART system (Figure 3-1), four alternatives – A1, A2, B1, and B2 - are proposed and compared to the status quo of truck-only transport (Lu et al, 2007; Sivakumaran, 2008, 2009a, 2009b).

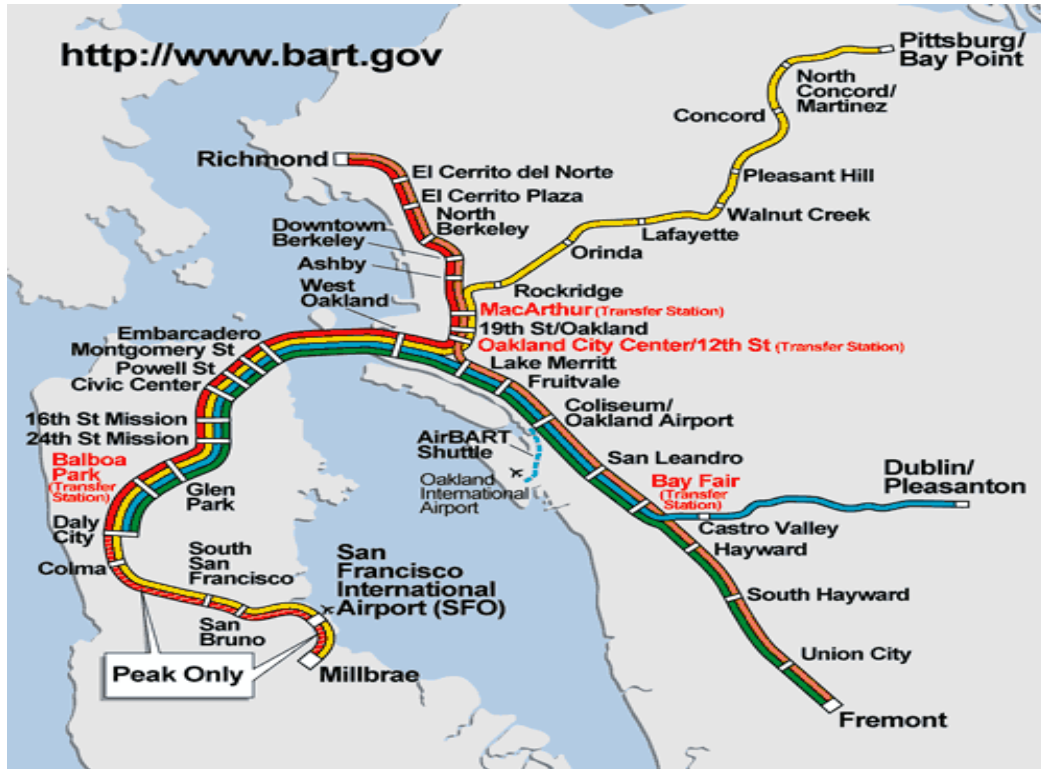

Figure 3-1. BART System Map (BART Trip Planner: www.bart.gov/)

Alternatives A1 and A2 consider only minor capital investment, while Alternatives B1 and B2 assume far greater capital investment, including a jointly operated BART/FedEx facility at another local distribution center in Oakland. However, Alternatives A1 and B1 make use of FedEx long-haul trucks for all goods movement, while Alternatives A2 and B2 utilize electric FedEx delivery trucks for local transshipments. Truck VMT, FedEx operating costs, BART operating costs, and CO₂ emissions are determined for the status quo and each alternative.

Analysis shows not only that significant truck VMT savings can be accrued from

mixed-goods service, but that upon passing a critical demand threshold, such service can both be profitable for passenger rail systems and cost-effective for air cargo carriers. If freight demand for a rail alternative is high enough, this may even lead to cross-subsidization, where in fact freight movement could help subsidize the movement of passengers. This would lead to less BART financial dependence on public subsidies, making the agency much more economically viable. Profits could potentially be used to improve connectivity to BART system for increased ridership, for example, which would lead to improvements in both passenger and freight service of BART system.

The following Table 3-1 is the preliminary estimation of FedEx demand between some OD. However, they are not the total demand since sine demand between the three airports: SFO, Oak and SJC are not included.

Table 3-1 Origin-Destination Demand Matrix (lbs)

	1a: RHV	2a: HWD	3a: LVK	5a: CCR	6a: SFO	7a: SQL
4a: From OAK	36,600	27,600	25,800	26,400	51,000	31,800
4a: To OAK	120,000	43,800	198,000	102,000	153,000	72,000

Table 3-2 Summary of the Scenarios Considered

	1	2
A	Little capital investment CTV5 Trucks for local transshipments; Existing BART yards and maintenance areas for access point; Dedicated freight train	Little capital investment Electric trucks for local transshipments; Existing BART yards, stations and maintenance areas for access point; Dedicated freight train
B	CTV5 Trucks for local transshipments; BART connection between OAK and Coliseum Station; Certain capital investment for retrofitting of existing BART stations for goods movement; Dedicated freight train	Electric trucks for local transshipments; BART connection between OAK and Coliseum Station Certain capital investment for retrofitting of existing BART stations for goods movement; Dedicated freight train

The network of BART system, its stations, yards, tail-track and shop and their schematic relationship with FedEx collection/distribution centers are depicted in Figure 3-2 for scenario A1 and A2, and in Figure 3-3 for scenario B1 and B2

R	San Jose
H	Hayward
O	Oakland Airport Hub
S	San Francisco (near
S	South San Francisco
C	Concord
L	Dublin

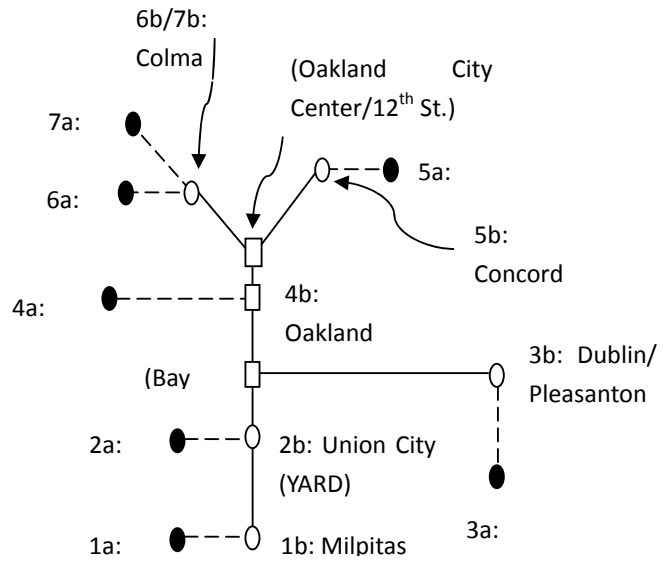

Figure 3-2. Mixed-goods BART network in Alternatives A1 and A2

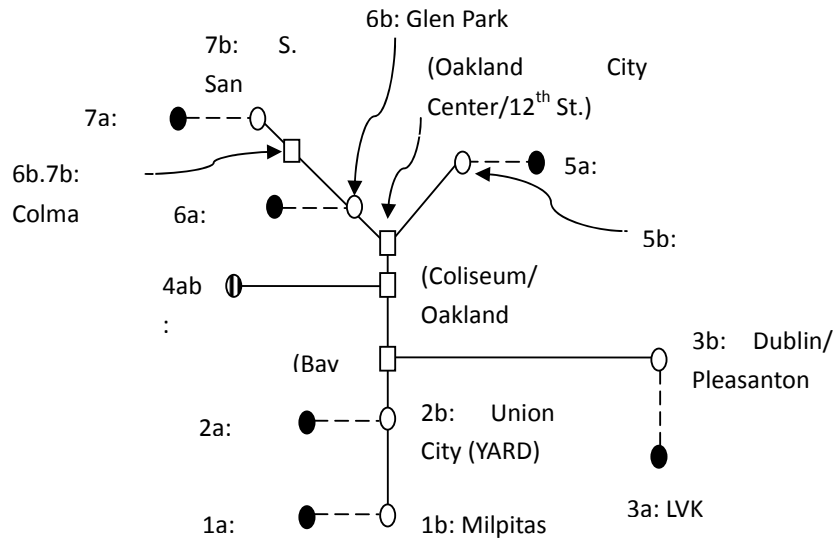

Figure 3-3. Mixed-goods BART network in Alternatives B1 and B2

The main results are plotted in Figure 3-4 ~ Figure 3-12, corresponding to the Status Quo, Alternative A, and Alternative B. The level of subsidy required will simply be the difference between the total cost of a given alternative and the total cost of the status quo. Any years which indicate a negative level of subsidy indicate that no subsidies are required; rather, opportunities arise for BART profits and FedEx savings.

For Alternative A, which requires minimal capital investment, some subsidy is required throughout the timeline, roughly \$3M each year. However, tremendous savings in truck VMT can be achieved; the cumulative truck VMT savings over the analysis period amounts to nearly 60 million VMT. This translates to more than 60,000 tons of CO₂ emission savings.

For Alternative B, which requires more significant capital investment but eliminates one of the transshipments required in Alternative A, even greater savings in truck VMT are achieved. The cumulative VMT savings amount to more than 100 million VMT, which translates to more than 110,000 tons of CO₂ emission savings. Perhaps most interestingly, no subsidy is ever required for Alternative B. Thus, if container demand is sufficient, BART mixed-goods service can both be profitable for BART and beneficial for FedEx from solely a fiscal perspective. The exact levels of profit for BART and savings for FedEx will simply depend on a mutually agreed-upon price for transported containers. Assuming a discount rate of 5%, the accumulated amount of total cost savings compared to the status quo amounts to roughly \$100M. These savings can be channeled towards recovering the initial capital investment, as well as towards improvements in passenger service, which can further incentivize transit ridership.

However, note that there exist other social benefits not included here, such as reduced congestion, noise, particulate matter reduction, and more economic land use. Government agencies must weigh all of these benefits against any required subsidies or start-up costs in order to determine whether or not mixed-goods service is worthy of pursuit.

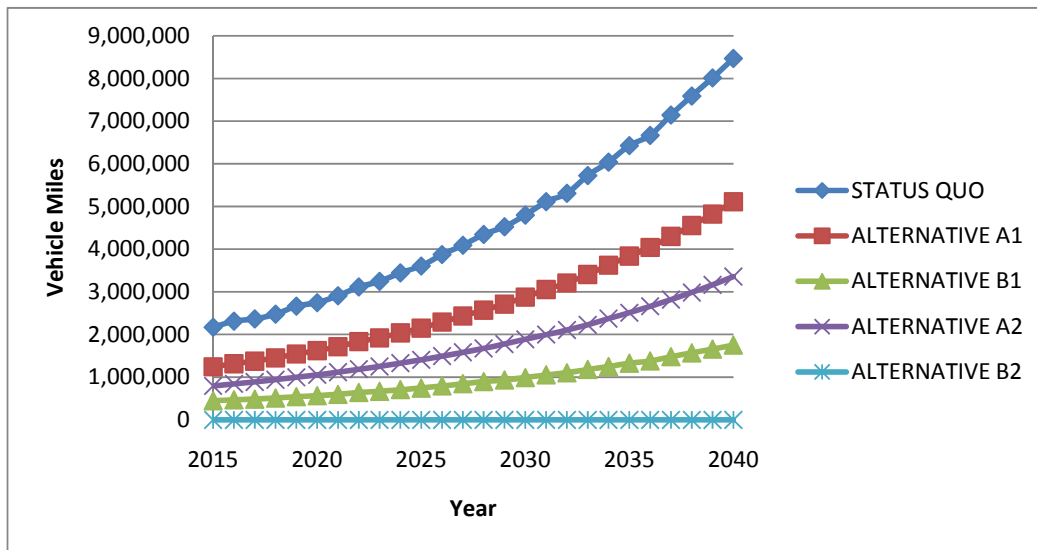

Figure 3-4 Truck VMT (Vehicle Miles Travelled) for Different Alternatives; the VMT

Reduction Can be Inferred

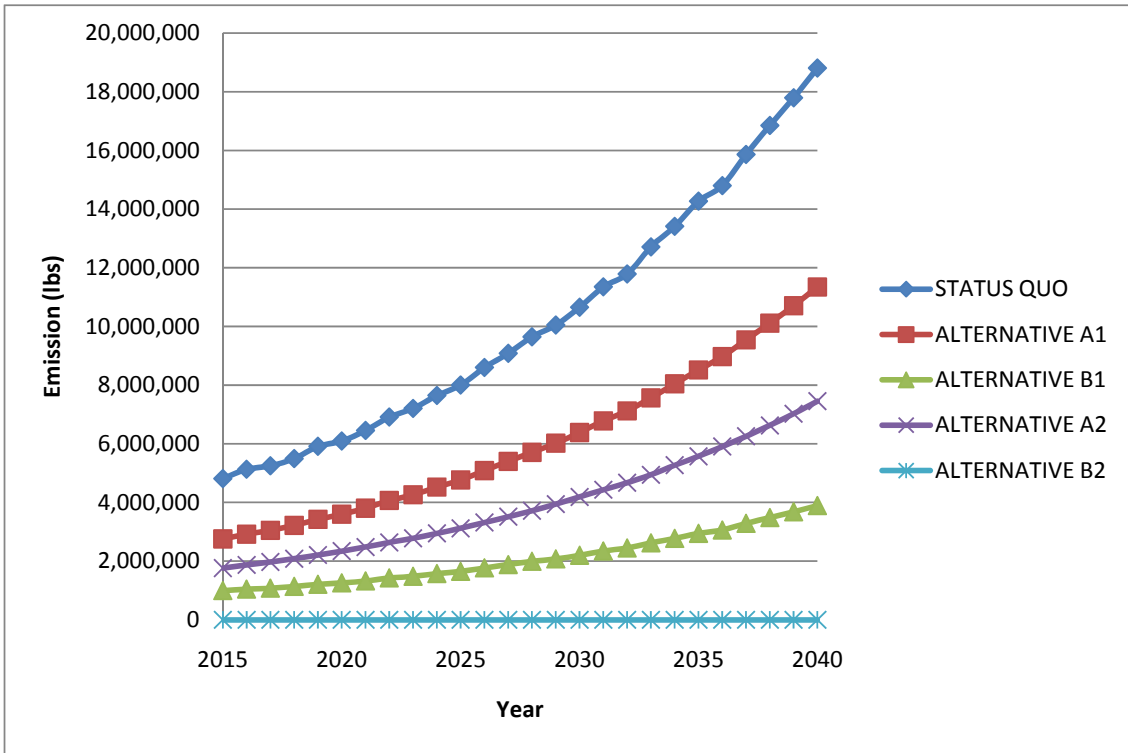

Figure 3-5. CO2 Emission for Different Alternatives; Emission Reduction Can be Inferred Accordingly.

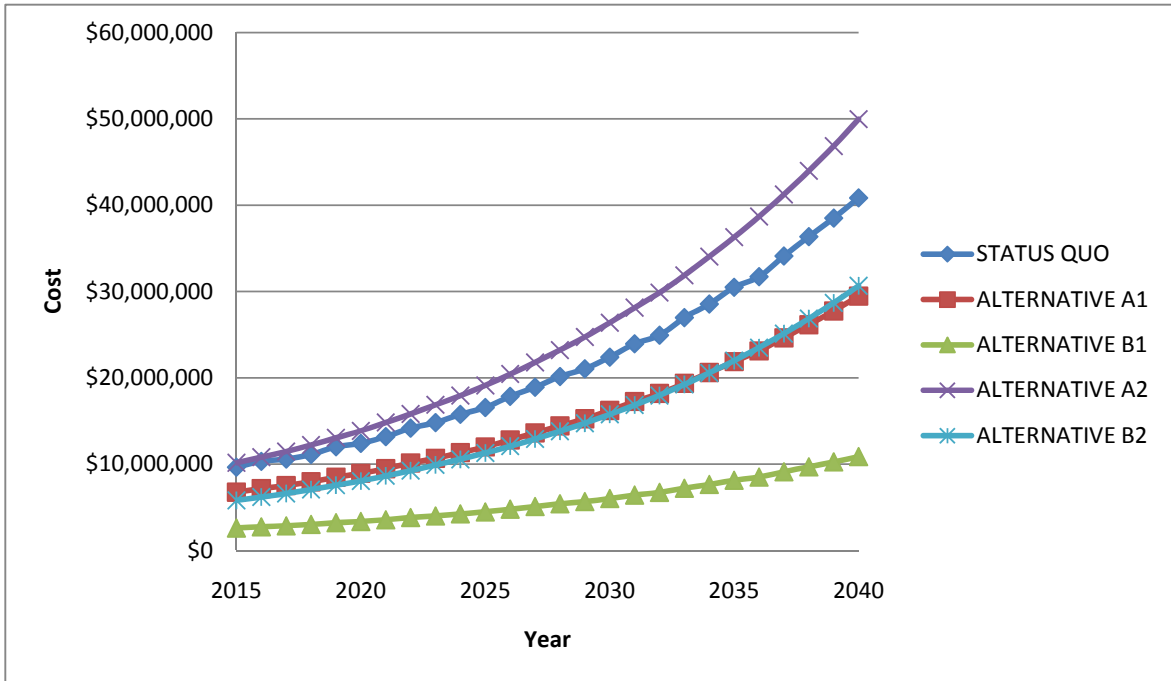

Figure 3-6 FedEx Cost for Different Alternatives

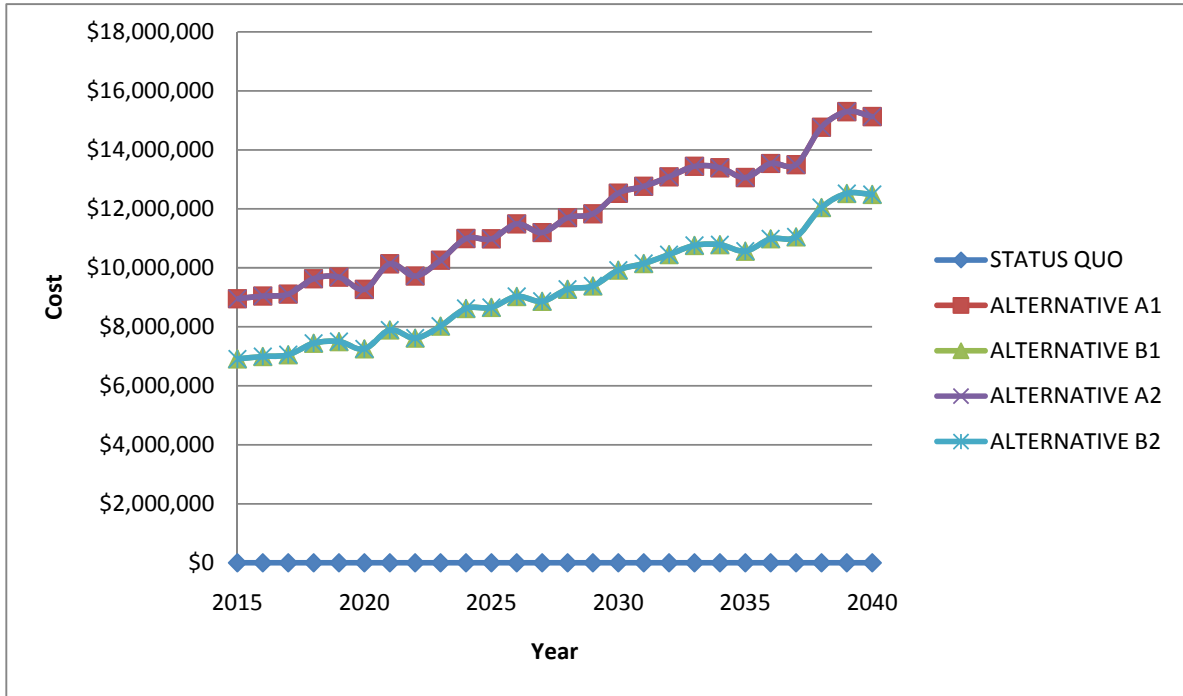

Figure 3-7 BART Cost for Different Alternatives

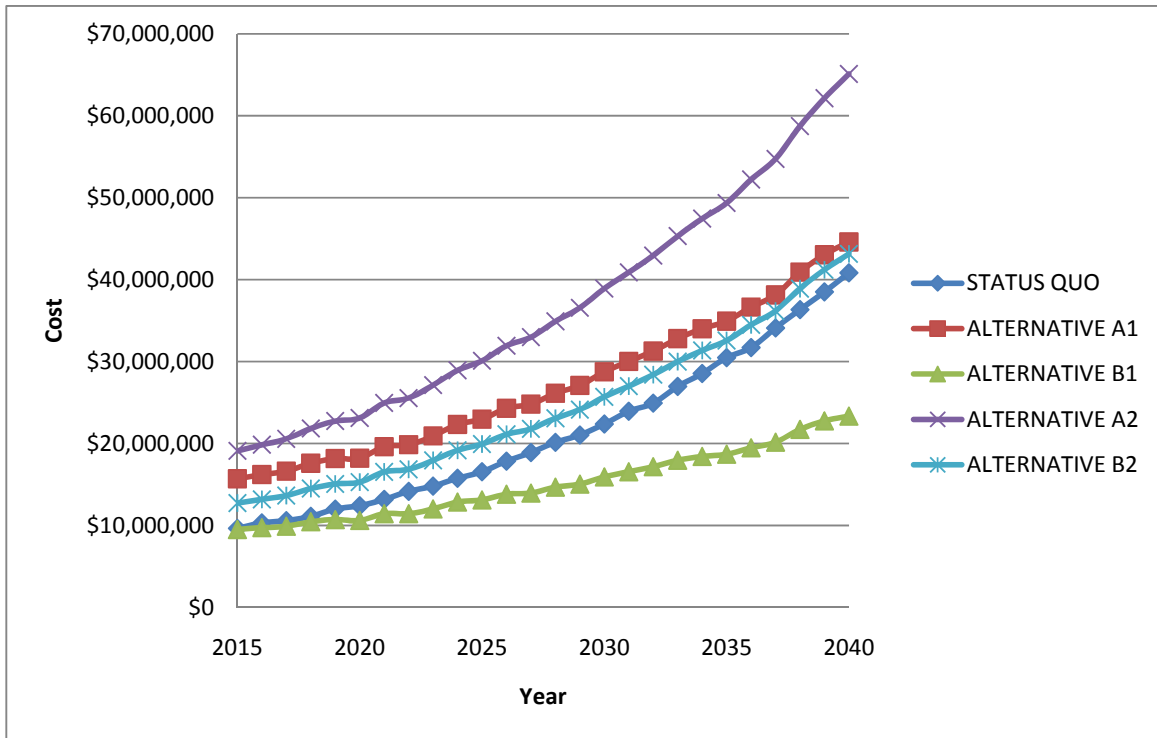

Figure 3-8 Total Cost for BART and FedEx for Different Alternatives

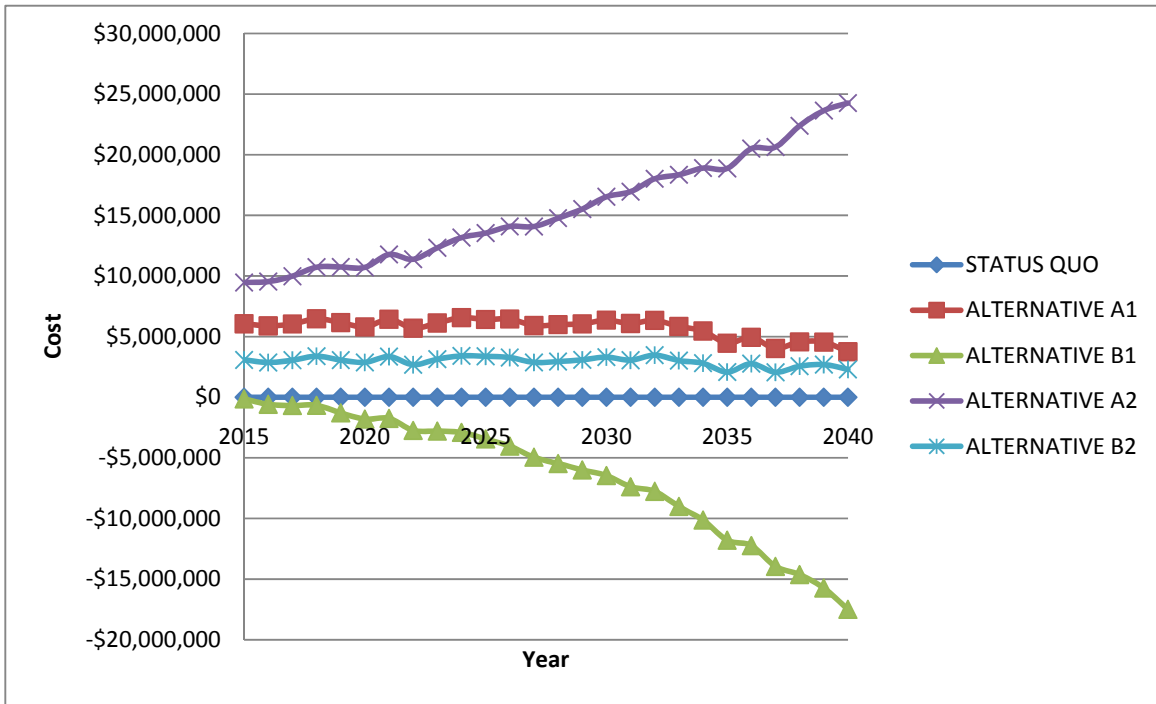

Figure 3-9 Minimum Subsidy Required for Different Alternatives (Negative Subsidy Indicating Net Revenue Gained)

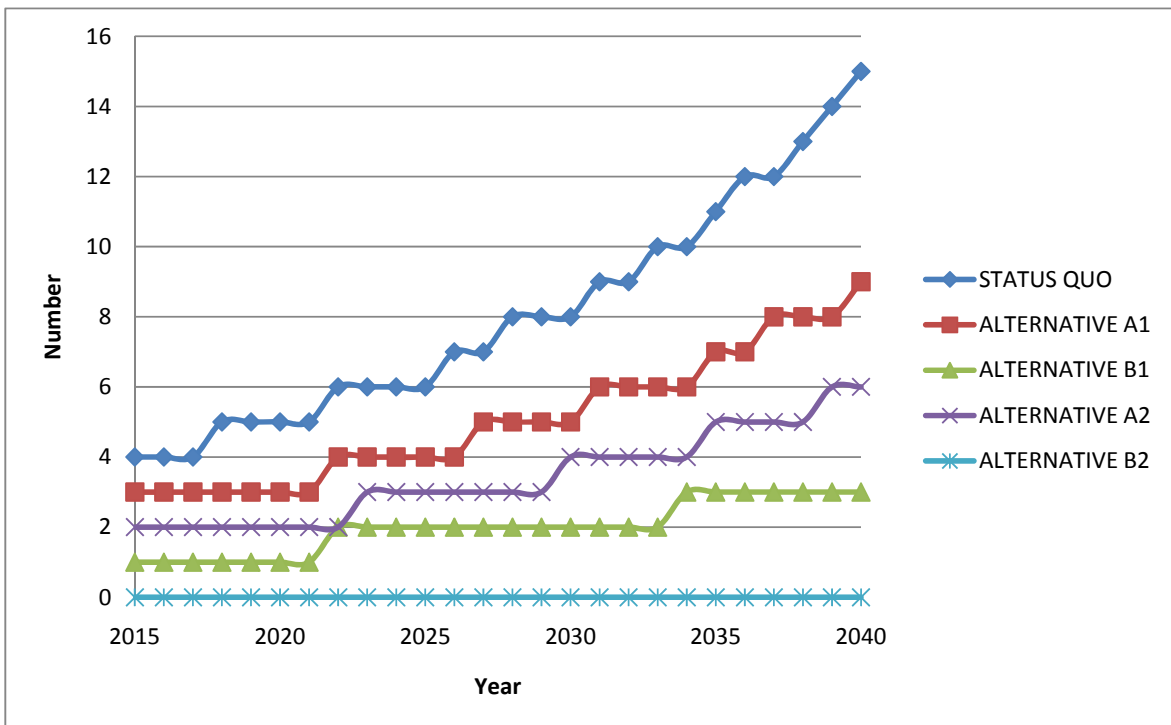

Figure 3-10 Number of Accidents for Truck Operations to FedEx for Different Alternatives

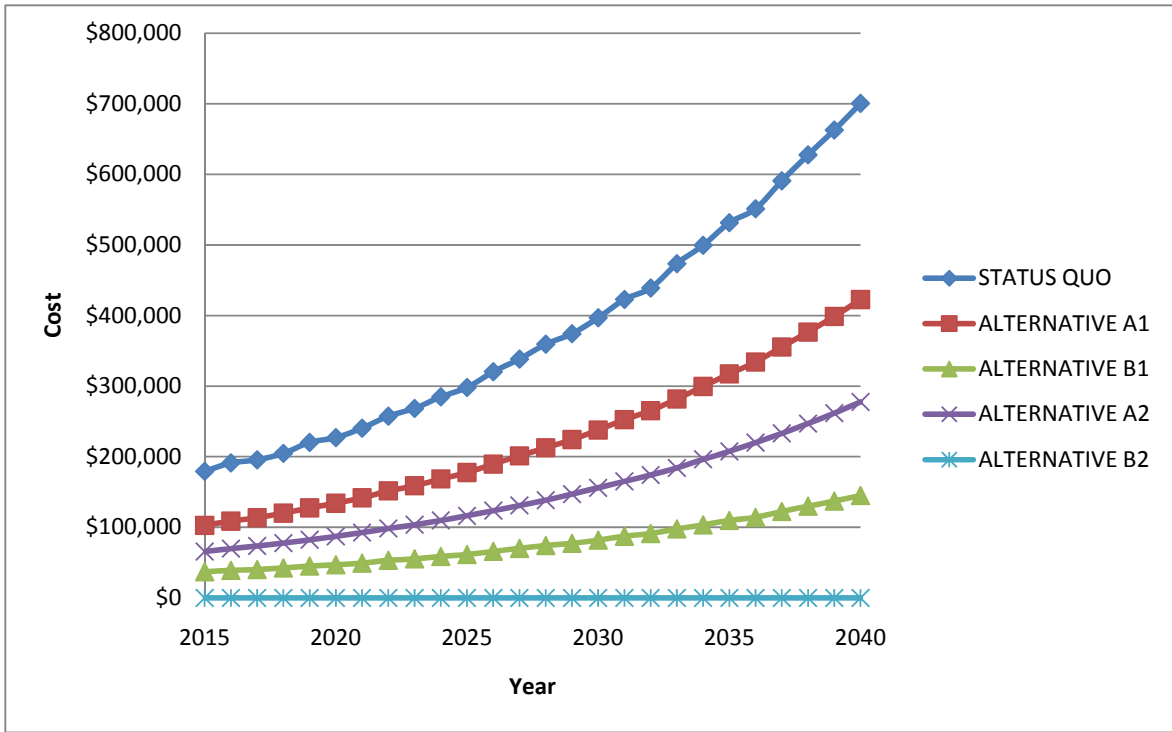

Figure 3-11 Accident Cost for Truck Operations to FedEx for Different Alternatives

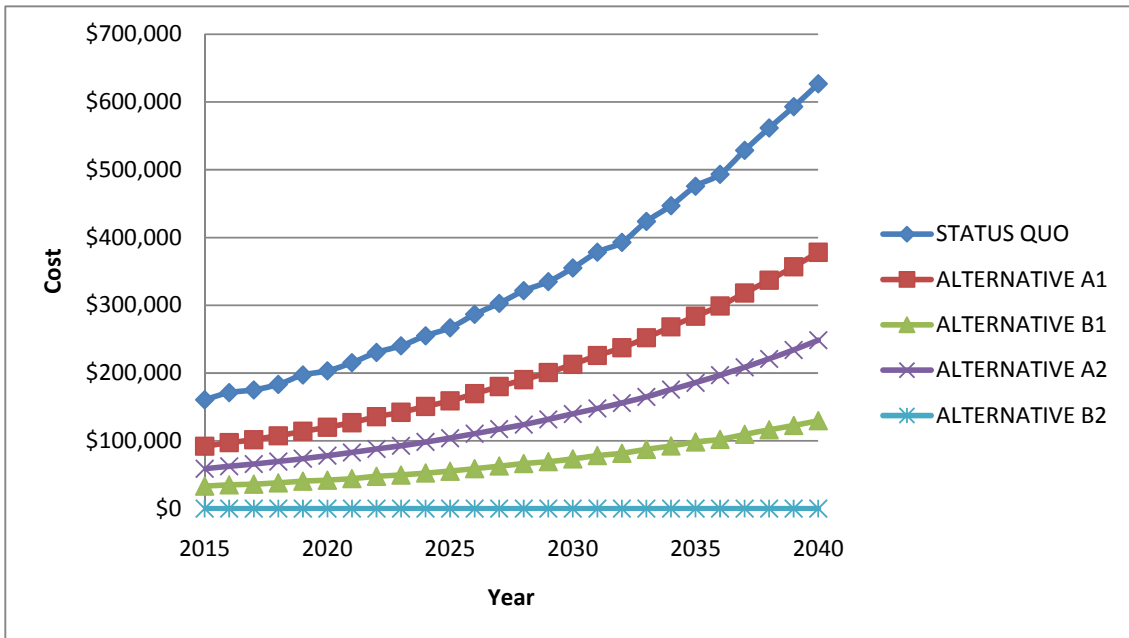

Figure 3-12 Maintenance Cost to FedEx for Different Alternatives

Chapter 4. Reliability for Air Freight Movement

The reliability of service is very critical to the integrated freight carriers, particularly for fixed time window delivery express services. The loss of reliability is very expensive to those carriers. The reliability could be quantified as percentage of services that can meet the limited or fixed time window delivery requirement. The integrated freight carriers can, in principle, to develop a good operational logistics if the products are in their side. For example, arrange their flight during the night. However, the main problem lies in the interaction with the customer through the roadways. In the Greater Bay Area traffic network, one critical links is the cross-bay bridges and the highway 24 Caldecott Tunnel. In case there is any incident/accident, the traffic will be blocked and delayed will be incurred. The bay bridge is carrying 270,000 vehicles per day, and may be closed due to serious incident and for maintenance/construction. During the closure, the crossing-bay trucks need to go all the way down to San Mateo Bridge for moving goods between San Francisco and Oakland, which induces significant cost of labor, fuel and time.

As discussed with FedEx engineers on February 22 2010, there will be some major changes to FedEx's operation scheme in the April 2010. Those will include:

- A new FedEx flight, from OAK to Tokyo, involves overnight delivery from SFO to OAK, will be operated by adding at least 3 trucks per night in addition of previous 7~8, 3 nights per week. The products will be leaving SFO at 11PM, and arrive at OAK at 3:30. The flight to Tokyo is at 4:30 AM.
- At least 6 additional trucks will travel from SFO to OAK daily, in which more than 3 deliveries will take place during peak hour at 5:00pm.

The modification can potentially provide an additional demand source for the proposed BART service, as well as present an opportunity for a small scale demo/operation. BART Millbrae Tail (to SFO) Track and Coliseum Station (to OAK) would be the preferred access points.

BART can be used to avoid the loss due to unreliable traffic due to congestion or other

factors such as incident and accident. In this chapter, we are trying to discuss the issue from the aspects of transportation delay, and emergency.

4.1 Transportation Delay

The BART system is well coordinated electronically, and free from congestion, and therefore maintains a high level of on-time rate, while the travel time of truck is of higher variability. Despite the good performance of truck during light traffic, on-time delivery is the most critical issue in mailing service. So the travel time reliability is determined by the worst case scenario, which is the delay during congestion. The scheduled travel time for truck is usually calculated as

$$\text{Scheduled Travel Time} = \text{Expected Travel Time} \times \text{Flexibility Factor}$$

The expected travel time for truck is time specific. For example, longer travel time will be expected during peak hour around 5 pm. The travel time in BART system is fixed. In regular traffic condition, similar expected travel time is required for both modes. During peak hour, time required in BART is comparatively less.

In the case of off-peak operations, we have been discussing the probability of using the BART for freight movement during non-passenger hour, such as 4-5 am. In this case, non-stop transport can be expected, and hence reinforces the advantage of the BART in travel time.

In addition, there exists high variability in travel time on truck. The FedEx is adopting a flexibility factor of about 1.35 to accommodate the potential unexpected delay, which is to say, for a 50 minutes expected travel time, a schedule of 67.5 minutes is required.

The flexibility factor does not apply to the BART. The schedule of the BART is usually accurate, especially on weekdays. The not on-schedule rate is less than 5%, a large percentage of which is on weekend operations, which is irrelevant to our case. Comparing with the unpredictable road traffic condition, the delay in BART is usually pre-scheduled, and therefore adjustable. Most of the time, the delay is 10-20 minutes, which is about a headway. As the result, departing one headway before schedule is sufficient for the flexibility

requirement.

4.2 Emergency Situation Handling

The closure of the bay bridge raises extra cost and inconvenience as discussed before. The abrupt closure has more serious impact, as the schedule and rerouting cannot be adjusted before departure. The freight may miss its flight or its promised delivery date, which is one of the most unfavorable situations for a mailing service company.

Serious as the consequence is, the frequency of bay bridge closure is higher than expected. On October 28, 2009, three pieces of an emergency repair to the bay bridge's cantilever section made over the previous Labor Day weekend snapped and crashed onto the deck of the span, striking three vehicles and forced the closure of the region's busiest bridge. The closure lasted for six days, but was still facing another closure for more permanent fix.

On the other hand, the BART system is not facing the problem with occasionally shutting down. As a matter of fact, it is keeping a good record in terms of accidental rate, which is once in 5 or up to 10 years, saving most of the effort in emergency response for traveling by road.

Although there is no quantitative assessment for the reliability level, it has been justified that the BART system maintains one of the highest level of on-time reliability. Switching to the BART system will also save the cost of rerouting as well as the loss due to unsatisfying service.

Chapter 5. Preliminary Social Impact Analysis

With the onset of the 21st century, the social cost associated with the increasingly congested traffic flow has become a significant social problem with expanding negative impacts that require instant measure to deal with. The social costs are usually referred to as externality. Negative on three aspects are discussed: road traffic congestion (delay, safety and land use), energy efficiency and environmental. The monetary cost of emission is calculated. Strictly speaking, the energy consumption and efficiency are closely related to environment, which are gradually paid more attention in transportation planning. Since the most previous study on environmental impact was focused on emission pollution, energy efficiency is discussed separately.

5.1 Road Traffic Impact

In the bay area, the road traffic is always the majority group in transportation. Therefore, improvement on the road traffic performance is a main momentum of promoting adopting another transportation mode. Relieved traffic load gives chance to improve traffic efficiency, as well as solve the long-existing land-use problem.

5.1.1 Road Traffic Relief

By converting the truck transportation into railway transportation, one major contribution is the road traffic release, especially on highway. This directly leads to the reduction in transportation time and the improvement of efficiency of the entire community.

A high percentage of improvement usually can be achieved by a relatively smaller amount of reduce in traffic load, especially during peak hour. The marginal cost of public transportation is increasing rapidly as the road approaches its capacity, which is to say, when the traffic flow is high (i.e. during peak hour), the transportation speed is highly sensitive to any additional traffic load. As the result, the improvement in transportation efficiency is much better (sometimes 5 to 6 times better) than what is forecasted on the proportion of reduced traffic load. According to the delay versus VMT during weekday

PM peak hour in 2004 throughout California, 8% VMT increase occurs at a cost of 66% delay.

Therefore, the traffic relief resulted from switching freight movement onto the BART system can benefit the entire society by a larger extent.

In the meanwhile, switching of transportation mode is one of the most cost-effective ways in reducing the freeway congestion, especially when comparing with the approach of freeway expansion, which involves large cost as well as potential induced demand. The expansion issue is also facing the difficulty of limited land resource.

5.1.2 Land Use

The reduce of road traffic load provides an alternative solution to the inadequate freeway capacity, which reduce the necessity of freeway expansion,

It should be noted here the two problems freeway expansion faces. Firstly and obviously, the availability of land resource is not sufficient. Freeways are usually surrounded by residential, commercial or municipal buildings, and farmland, which cannot be eliminated. Study based on Greater Lansing, Michigan area shows that a loss of \$300 million due to farmland loss can be expected by the year of 2010. The indirect negative impact makes the freeway expansion always a controversial issue and difficult to implement.

Secondly, the expansion of freeway seldom proves to be improving the traffic condition. This is due to the induced traffic load, which is to say with the expansion of freeway, more vehicles will tend to enter it. The improvement is not as efficient, and in some case, may work in the reverse direction.

Therefore, changing of traffic mode, into BART system in this case, is the optimal solution, which contributes to the improvement of both the transportation and land use efficiency.

5.1.3 Traffic Safety

In terms of community security, the accident risk is a concern for both transportation modes. The accidental rate of trucks is discussed previously and is presented in the appendix, which is about 1.6×10^{-6} , while with large truck quantity, this actual number of accident occurrence is significant. The number of truck crash in year 2006 is 368000. The accident rate of BART is way smaller, as the total number of accidents is about 1 in 5 years.

The social security discussed here includes two parts, the security of drivers and pedestrians. Not only is the security of driver directly related to the accident rate, of which the improvement is clearly observed. At the same time, the benefit of pedestrian for improved transportation security can be applied to a much larger scale, which is nearly every single person in the community. It is important to realize that the accidents can be fatal, so the real accidental cost cannot be expressed in monetary value. The improvement in crashing risk is, by all means, desirable. This is believed to be a great contribution to the overall social security.

5.2 Energy Efficiency

As introduced in the previous section, a comparison of energy type and amount by the two transportation modes is illustrated below. As mentioned before, the BART is motivated by electricity, while trucks are usually motivated by fuel combustion

Table 5-1. Energy Resources and Efficiency Factors

	BART	Truck	Total Fuel Used: BART/TRUCK
Energy Resource	Electricity	Fuel Combustion	
Renewable Resource	53%	0%	
Fossil Fuel	47%	100%	0.141
Energy Efficiency	1	0.3	0.3

Source: the existing energy resources in Bay Area (The California energy Commission, 2007; 2009);

$$\text{Total Fuel Used: BART/TRUCK} = \frac{\text{Percentage of Fuel concerned in BART/Energy efficiency of BART}}{\text{Percentage of Fuel concerned in truck/Energy efficiency of truck}}$$

In the table presented above, we traced back the resources of electricity in the bay areas, and break them up in to renewable resources (wind, nuclear, etc.) and fossil fuel, of which fossil fuel takes up to 47% percent, with a declining trend. The energy efficiency of truck is usually 30% that of train due to friction. As a result, the fossil fuel used to generate the same amount of motivation for the BART is about 14% that of truck, without considering route difference. In real practice, the route of the BART is shorter than truck, because it is operated underground, and serving direct route between two stations.

It can be observed that an impressive improvement of energy efficiency can be achieved by switching the transportation modes. In addition, a major part of energy resource of BART is renewable, which fits well into the current running out of energy resources, especially fossil fuels, problem.

The percentage of renewable energy is increasing for both the transportation modes. If a longer period of time is considered, it should be predicted that in recent 20, or maybe up to 50 year, the percentage of renewable energy used in electricity generation can increase significantly. The trend can be observed in the past 10 years, due to the maturing technology and the shortage of resources as impetus. On the other hand, the switch of energy resource of trucks will take a longer and slower process. This is largely because the technology has much room to be improved to put into large scale use. At the same time, the shift of energy resource leads to the replacement of cars. Considering the large amount of car ownership, the replacement is also a slow and difficult process.

As a result, the changing of traffic mode is a good solution to the energy issue at the moment, and the best time to do it is now.

5.3 Environmental Impact

Environmental impact considered here includes the pollution of noise and emission, which are the most harmful factors to human life.

5.3.1 Noise

Noise pollution affects people's living quality as well as working efficiency. Road transportation always induces the major amount of noise in urban area, especially during peak hour, due to the vehicle's engine, friction and etc. On the other hand, most of the BART system is underground or in relatively remote area, where the noise effect is minimal. At this point, the BART system almost eliminates the noise effect.

5.3.2 Green House Gas (GHG) emission

The concepts of direct GHG emission and indirect GHG emission are adopted here. As because we are trying to consider the entire picture, it is more convincing to consider the amount of emission not only due to operation, but also the part generated during energy generation process. This part of work is a further refine and improvement of previous work (Sivakumaran, 2009b).

The GHG emission due to fuel combustion is the direct emission. In particular of this study, the direct GHG emission is the CO_s emission by truck. However, because the energy resources uses to generate electricity, which is later used to operate the BART system, May also involves fuel combustion. This part of emission will be considered as the indirect CO_s emission

By simple analysis, a relationship can be obtained as below.

$$\begin{aligned} \text{Total GHG} &= \text{GHG Generating Rate} \times \text{Fossil Fuel Combusted} \\ &= \text{GHG Generating Rate} \times \frac{\text{Energy Required} \times \text{Percentage of Energy by Fossil Fuel}}{\text{Energy Efficiency}} \end{aligned}$$

From existing data, the energy efficiency of train is about 70% higher than that of truck, the percentage of fossil fuel used to generate electricity is about 45 percent. As the result, GHG emission by BART is about 13.5% that of the truck. The amount reduced (refer to appendix), is on the scale of 10⁶lbs, and 10⁷lbs in 20 years.

The details of the assessment of the emission will be presented later. It should be noted here that environmental pollution is usually irreversible. Contemporarily, increasing negative impact of social significance is emerging, which is an alarm to the community. The emission should be prevented from increasing at the current rapid rate. Measures must be taken as early as possible.

5.3.3 Particulate Matter (PM) Due to Tire

Besides GHG, the rubber particles released due to the friction is a significant source of PM in air pollution. The amount of PM due to friction is even larger than that due to diesel combustion emission. PM has effects on health (asthma, lung cancer, etc.), climate, and etc. After switching the transportation mode, the rail transportation system eliminates the friction process, which gives a zero level of PM emission. This can be a large step in reducing the negative environmental impact by transportation.

5.3.4 Quantification of Environmental Impact

This section will focus on the environmental impact of the vehicle emission. Comparison of different scenarios will be analyzed. For comparison purpose, the emission will be converted into monetary value. The respective converting rate will reflect the social impact.

Methodology

The methodology in this section is similar to that of the analysis of carbon dioxide emission in the previous section, while CO₂ is not a pollutant; its respective social cost is also calculated here. The discussion of emission of each substance is also based on direct and indirect emission, of which the emission factors is the same as that adopted in the previous section, because the indirect emission factor is calculated through energy efficiency, which is the same for all the substances.

Type of Emissions Considered

Substances discussed in this section includes:

- carbon dioxide (CO₂), as mentioned before, although carbon dioxide is not a pollutant per se, it is a green house gas which plays a role in global warming;
- Nitrogen oxides (NO_x): a precursor of smog and acid rain;
- Carbon monoxide (CO): reduces the blood's ability to carry oxygen and is dangerous to people with heart disease;
- Particulates matter (PM₁₀): causes respiratory health effects on humans and animals;
- Sulphur oxides (SO_x): also a precursor of smog and acid rain;
- Volatile organic compound (VOC): similar atmospheric and health effects.

Emission Factor

From existing documents, the emission factors adopted in this project are as following:

Table 5-2: Pollutant Emission Factor (Source: Oxford Economic Research Associates, 1999; Matches, 2009)

Pollutant	PM10	SO2	Nox	VOC	CO
Emission Factor (lbs/hp-hr)	0.0022	0.00205	0.031	0.002514	0.00668

Social and Environmental Cost Factor

A study has been conducted to analyze the cost induced per unit weight of emission. The impact of emission is not linear with respect to the emission quantity, as it is obvious that the emission cost per unit extra amount of emission is increasing. As a result, the cost can be a complicated function with respect to the environmental pollution situation at the time under discussion, the analysis of which may even involve programming. However, the overall environmental situation is not clear for the future, considering the commitment to reduce emission of almost every country in the globe and, however, the still increasing industrialization. So the social and environmental cost is calculated

separately for low and high pollution level. Representative social and environmental costs discussed here include:

Table 5-3: Emission Unit Cost Factor (Source: Delucchi, 2000)

Health (\$/lbs Emitted)			Visibility (\$/lbs Emitted)		Crop Loss (\$/lbs Emitted)		Total(\$/lbs Emitted)		
Emission	Ambient Pollutant	Vehicle emissions, US		Vehicle emissions, US		Low	High	Vehicle emissions, US	
		Low	High	Low	High			Low	High
CO	CO	0.00	0.04					0.00	0.04
NOx	Nitrate			0.09	0.50				
	PM10	0.46	7.51					0.46	7.51
	NO2	0.07	0.33					0.07	0.33
Total for NOx		0.53	7.84					0.62	8.35
PM2.5	PM2.5	4.73	72.21	0.18	1.77			4.73	72.21
PM2.5-10	PM2.5-10	3.04	8.02					3.04	8.02
Total for PM10		4.42	60.68					4.60	62.45
SOx	Sulphate			0.40	1.80				
	PM10	3.13	29.72					3.53	31.52
VOC	Organic			0.00	0.02				
	PM10	0.05	0.52					0.05	0.54
VOC+Nox	Ozone	0.00	0.05			0.10	0.15	0.00	0.05
CO2								0.00	

Health cost: derived from the value of lost work days, of restricted activity, of tolerating certain symptoms, and so on;

Reduced Visibility: derived from the diminishing enjoyment of scenic vistas and increasing danger of traveling;

Crop Loss: impact of air pollution on agricultural production.

Obviously, there are other costs such as material damage and forest damage which are not calculated here.

Analysis Result

The calculation is based on the VMT (Vehicle Miles Travelled) of truck activities of different alternatives: A1, A2, B1 and B2 (Sivakumaran et al, 2008, 2009a, 2009b) as reviewed in previous section.

The figures are only representative, as some other costs of negative impact are not included. Some of them are difficult to quantify. The results can be used to qualitatively indicate the following:

- (a) The cost to of social well-being and community life due to pollution: The difference between low and high pollutant status indicates the high risk associated with the worsening of the environment;
- (b) The cost is non-cumulative: i.e. this is to say that the rate of the cost due to emission per year is increasing (accelerating essentially Figure 5-1) at the scale of million dollars, which reveals the worrying fact that, we may be losing tens of millions of dollars without noticing;

The results shown in Figure 5-1 should be compared with that of CO₂ only in Figure 3.5.

The accelerating trend of the growth of negative impact implies that, sometime in the future, the negative impact may be out of control. Therefore before that moment, we should do everything we can to prevent it happening. The best moment to start is now. This concludes that the serious emission reduction procedures by all means are absolutely necessary and very urgent. .

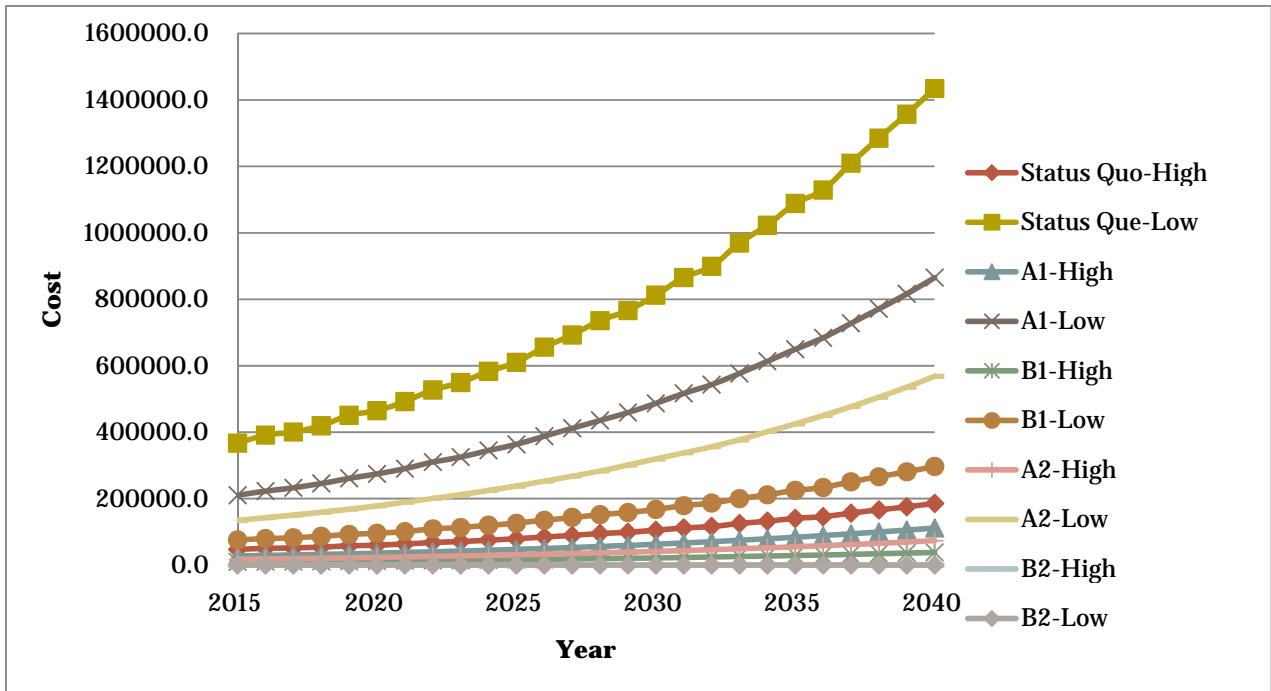

Figure 5-1. Emission Cost Forecast (California Energy Commission, 2009)

5.4 Further Remarks

All that discussed above are the direct or nearly direct effects. However, the combined effect in the long run may be of even more significant social consequences, which cannot be assessed at this stage.

On one hand,, once the freight-on-BART system is put into implementation, this transportation mode is not only applicable to FedEx, but also relevant to the products some manufacturers, which are light in weight but high in value and there is a large customer demand such as computer parts and medicine. All these companies can benefit from the new modes, and the revenue of BART may increase subsequently

On the other hand, with the economic benefit taken into consideration, and with the accumulation of revenue, the BART system can improve its customer service, and become more competitive in customer transport. There is a clear trend that with the improvement of customer service, more people may switch into the traffic mode. Hopefully, in the end, BART will get out of this negative revenue→decreased service level→losing customer→negative revenue circle.

Furthermore, with the increased revenue, the BART system can be modified to improve its working efficiency, such as:

- Improve the capacity of BART system: BART system can be improved by adding by-passing track near critical stations;
- Adopting new control and communication system and control logistics;

All the above mentioned benefit of the BART system will magnify the social benefit in turn.

As the result, after the initial investment, the social and economic benefit will be generated accordingly. The different aspects of benefit within the system are not contradictory, but complimentary. It is believed that the system will be moving into an optimal direction with increasing scale.

Chapter 6. Infrastructure Feasibility

For practical operation, the feasibility of infrastructure and equipment has to be justified. In the following session, the feasible plans regarding this issue will be proposed, and the respective budget, benefit and disadvantage will be discussed.

The main point here is to share track for both passenger and freight movement. This is very popular in the Europe but not in the US. High as the development level of the Europe, the freight movement in the European system is also in better business situation.

The main factors for infrastructure feasibility include:

- Compatibility between BART car and the containers subjected to the constraints of BART system operation, safety and security requirements
- BART system access points – yards, tail-track, and stations
- Proximity of BART access points and the source of demand, in this case is the FedEx collection/distribution centers
- Transshipment between FedEx centers and BART access points

We will discuss some preliminary considerations about those issues.

6.1 Proximity of BART Access Point and FedEx Distribution Centers

To achieve a convenient access point is crucial for the loading and unloading process of the FedEx. Firstly and most importantly is to consider the proximity of BART stations/yards/shops and FedEx collection/distribution centers. Since FedEx Western Regional Hub at Oakland Airport is the center of all the spikes, its closest access point to BART system would be the most critical one.

A general access point can be described as a location which has the following characteristics:

- Ground vehicle accessible from public road
- The proximity of the ground vehicle to the rail for loading and unloading
- Safety and security - isolated from public access

- Adequate rail for BART car loading/unloading and operation (to move out in the expected direction – ideally two directions) in the BART rail system
- FedEx collection/distribution center at the proximity its has adequate demand (However, this need to be considered in a long run in the sense that: current demand might be low but other products nearby could become the future demand as the goods-movement-on-rail business developing)

Secondly, to put the issue into realistic circumstances, it is necessary to discuss the possibility of constructing an extra segment of rail (of approximately 100 to 150 meters length), at the point of access, to realize the loading and unloading.

Furthermore, as an extension to the project, in the future, it can be beneficial to build bypass rail and accommodate direct transit service, to increase the overall efficiency of the system.

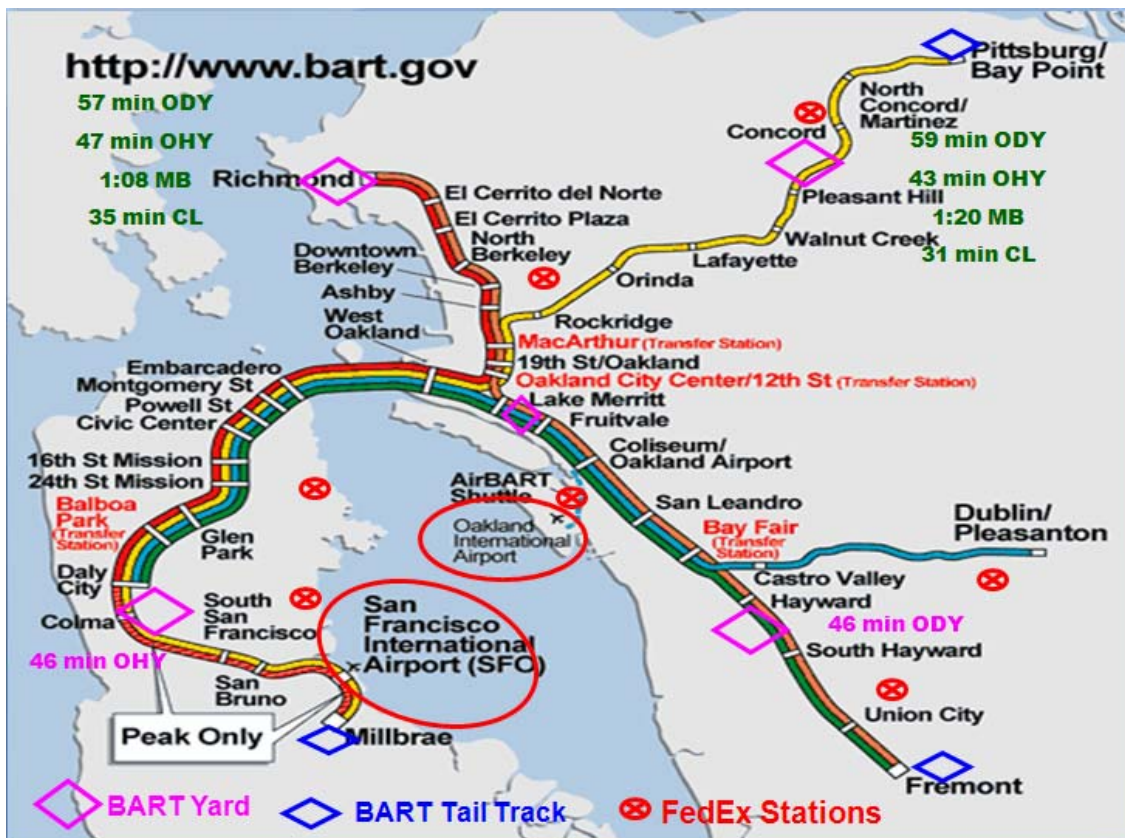

Figure 6-1. BART stations, shops and tail track and FedEx Collection/Distribution Centers

6.2 BART Cars for Dedicated Freight Movement

For non-containerized products or the products of USPS Express Service which uses smaller containers with wheels (Figure 06-2), the products could be directly put into current BART car as long it does not have seats, installed with restraints which are used fixing the containers on the car floor while traveling.



Figure 6-2. USPS Containers used by FedEx, small enough to fit in BART car

However, if we are going to use other FedEx containers, which will be discussed later, we need to find alternative solutions for BART car, either modifying from retired BART car or building from new. The following is the approximate size of BART car:

$$70[ft] (L) \times 10.5[ft] (W) \times 7[ft] (H)$$

Flat-bed cars such as those used on trains for freight movement car would be ideal for container loading and unloading. Besides, it is easy to obtain. However, for safety in operation, BART operation staff needs to be able to move from the head to the tail in case there is any fire etc in a closed passageway.

6.2.1 Suggested Modification Approach

The modification approach refers to the approach of modifying existing, but retired

cars from the BART. Procedures may involve:

- removing the seats from the car
- modifying the door to accommodate some (not all) larger containers without major modification of the enclosure
- rebuild the car (both the wall and the bed) to accommodate all the standard containers for air freight movement.

Cost for Modification

The cost of this approach is smaller compared with the others. The BART yard is capable of modifying, such as those located at Richmond and Concord.

For rebuilding the BART car, the time cost will increase. It is noted that the BART car renewal (retiring) rate is 8 cars per month, which has been planned starting from year 2016.

Expected Quantity of Retired Car

The BART is scheduling a car renewal plan, in which it is projected that 700 new cars will be put into use by year 2024.

In the schedule:

- (1) The first batch of ten pilot cars will be tested, during from January, 2014 to June, 2016;
- (2) During Phase I, the production is following to a base contract, which includes 200 cars, up to year 2017 (8 cars per month);
- (3) During Phase II, the additional 500 cars will be renewed. The renewal is to be finished in year 2024.

Comparing the scheduled renewal, and the car demanded by the FedEx freight, the following comparison is made:

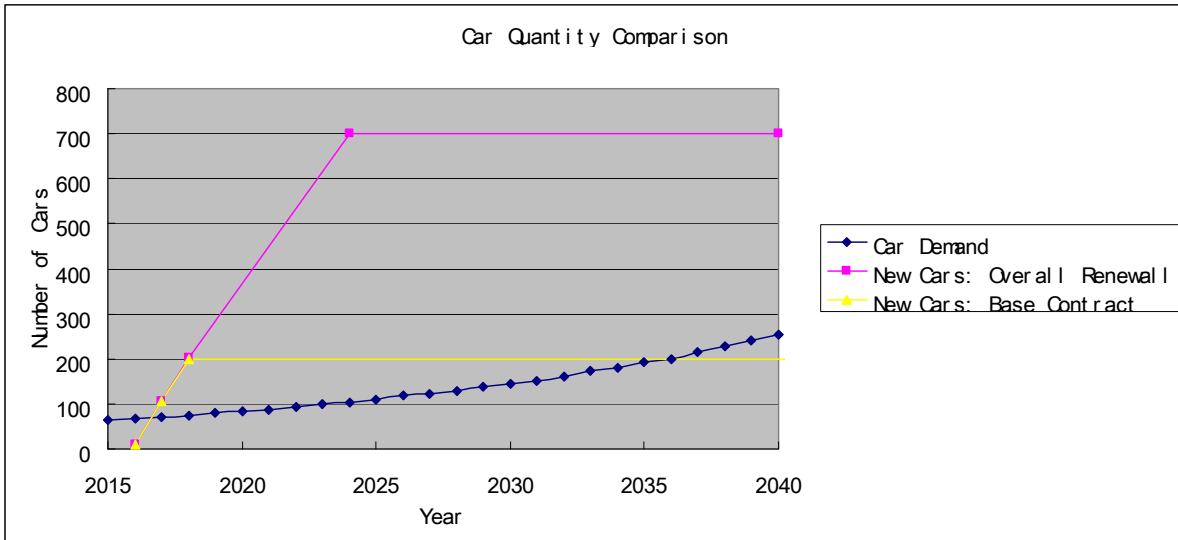

Figure 6-4. Car Quality Comparison (Resource: BART Board Workshop, New Carrier Interior Concepts, Apr. 09)

From the data, the retired cars can fulfill the FedEx demand from year 2017 onwards. Even if only the base contract is considered, the FedEx demand can be fulfilled up to year 2036. Therefore, within a twenty year horizon, the modification approach suffices even if only the base contract quantity is considered. However, this is only for the short term development and without considering other potential freight demand. The situation with all these conditions counted leads us to the consideration of purchasing new BARTs cars particularly designed for freight movement.

6.2.2 Purchasing Approach

Although contemporarily, the modification approach is optimal, considering its minimal cost, and reutilization of existing materials, design and purchase new cars is still in our consideration, especially when we place the project in a longer spectrum. There are a series of reasons to consider this:

Case study only focuses on the air freight demand from FedEx. However, our final objective is not limited to this. Once the system is adopted by freight movement, greater potential market exists in manufacture and agricultural products. The supply capacity of

the existing cars is inadequate once the service is expanded;

Although the modification cost may be lower, the cars are still subjected to the aging problem, and thus the maintenance cost will increase with time. Sometime later, the cars might become so costly to maintain such that purchasing new cars become a more viable solution.

The expense for BART car modification could be from the profit of freight movement. Once the system is in operation, the facility development can be conducted progressively according to needs.

6.2.3 Standard Air Freight Movement Containers

The equipment feasibility is part of the facility problem that concerns the container size and equipment for transshipment (loading and unloading containerized and non-containerized products).

FedEx currently utilizes the following container types to transport their items: USPS, LD3, AYY, SAA, AMJ (**Figure 6-5**), and AMJ pallets. Their respective dimensions are outlined in Table 6-1.

Note that all these container types including USPS containers as in Figure 6-2, are transported throughout the FedEx transport chain using ball-bearings; that is, items are not lifted onto pallets in order to be loaded onto trucks. Rather, containers are simply slid across platforms and aboard trucks via the casters mounted throughout loading platforms.

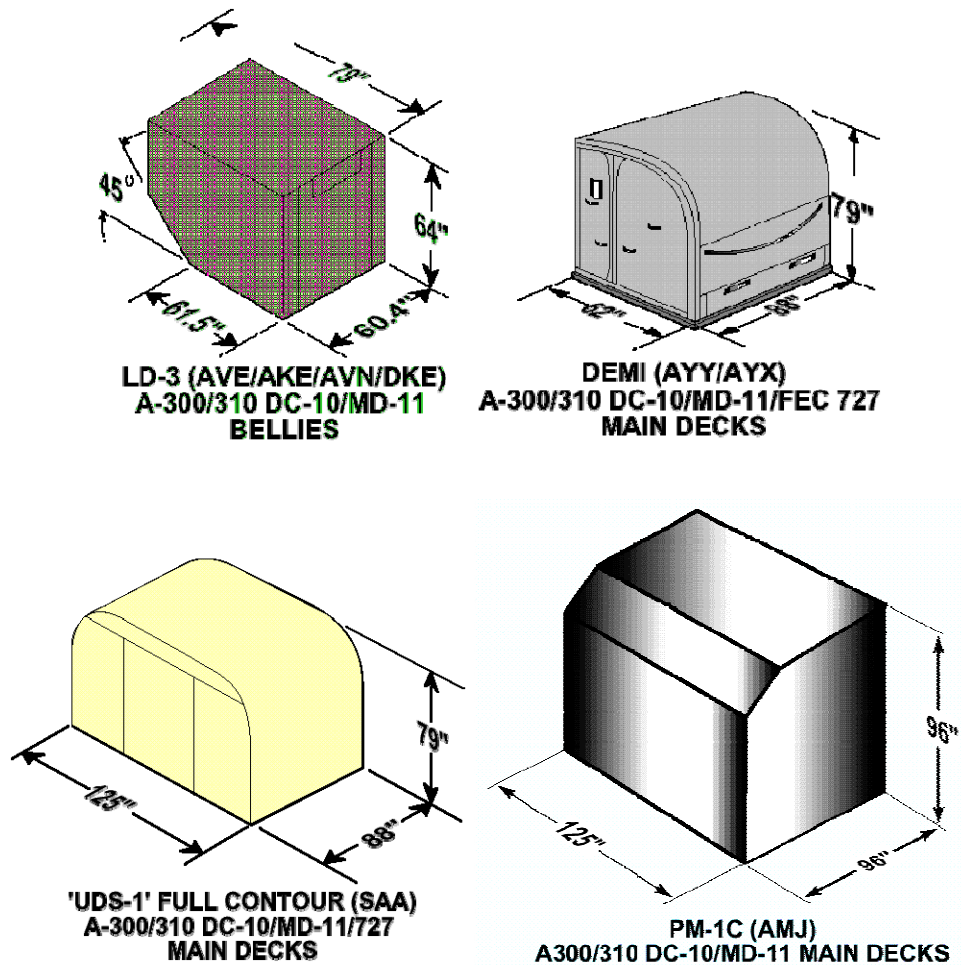

Figure 6-5: FedEx Standard Air Freight Movement Containers

Table 6-1. FedEx Standard Air Freight Container (Source: Presentation by Michael Graham of FedEx Express in June 2006)

Container	Length (in.)	Width (in.)	Height (in.)	Dry Weight (lbs)
USPS	69	42	60	550
LD-3	64	60.4	79	970
AYY	62	88	79	1270
SAA	125	88	79	2700
AMJ	125	96	96	3700
AMJ Pallet	125	96	variable	variable

6.3 Transshipment

The station accessibility problem, or can also be called as the transshipment problem, is a major obstacle in the operation. The difficulty comes from two aspects: monetary cost due to reconstruction, and time cost due to the operation delay.

Several factors need considering at terminals to allow for freight movement access.

These include

- Loading/unloading equipment
- BART access points
- Inventory space
- Security for closed operation

A critical factor in the ease of freight movement within terminals is the availability of access points – areas where freight trucks could access for container loading/unloading. Possible access points in BART system include: yards, tail-tracks, shops and stations. BART yards usually have multiple tracks for consist operation including turning around, storing cars, and building required consist. Maintenance is usually performed in shops. The yard accessibility has been discussed in more details in the report of previous phase (Sivakumaran, 2009b). The tail-tracks are also good candidate for access such as the one in Millbrae. It is could be used for truck access, parking, and for transshipment of containers between trucks and BART cars if appropriate equipment is available. However, some minor modifications might be necessary for such purpose.

6.3.1. Accessing BART Station

In the case of BART station, the freight container should have accessibility to the platform. As a result, additional modification of the platform is required to fit into freight movement.

However, most BART stations have limited loading space available for freight trucks

due to their locations within urban areas; for example, there would be little room for a 53 ft long FedEx truck to park at the BART Embarcadero Station located in downtown San Francisco. For those underground and aerial stations dedicated freight elevators will be indispensable. The former could be more expensive since the labor would be required to dig into the ground and there is need for seismic considerations which could be cost prohibitive. The cost of elevator for an aerial station is varying with its lifting distance and loading capacity. An estimation of the cost is shown in the following table.

Table 6-2. Cost (in \$) of dedicated freight lift for accessing BART aerial station(s)

Height(feet)	30	40	50	60	70	80	90	100
3,000 lb	55,900	61,300	65,900	69,800	73,400	76,600	79,500	82,200
5,000 lb	61,900	67,900	72,900	77,300	81,200	84,700	88,000	91,000
10,000 lb	82,500	90,500	97,200	103,000	108,200	112,900	117,300	121,300

At the same time, all these loading/unloading points (i.e. annex shop, BART yard, BART station) may require pallets or ball bearings (Figure 6-6), such that the freight containers can be moved over some area of the platform which should not be accessed by passengers.

Table 6-3: Required Modification

	Pallets or bearings	Elevator	Modification on platform
Annex Shop	✓		
BART yard	✓		
BART station	✓	✓	✓



Figure 6-6. Roller Mat or Ball Bearing for Container Transshipment (Source: FedEx Western Regional Hub)

To achieve higher transshipment efficiency, one crane will be introduced at each transshipment point. The equipment of rolling pad is readily available from FedEx, so only modification cost need to be considered.

Based on all the above assumptions, the cost of establishing transshipment facility is

Table 6-4. Transshipment Capital Cost

	Cost (\$)	Quantity	Sum (\$)
Annex Shop	15,000	1	15,000
BART Yard	15,000	3	45,000
BART Station	100,000	2	200,000
Total	260,000		

The time required for the transshipment per container is estimated as follows:

Table 6-5. Transshipment Time

	Time Consumed (min/truck operation)
Annex Shop	1.50
BART Yard	1.50
BART Station	2.50

6.3.2 Transshipment between BART Car and Trucks

Transshipment could be conducted in several possible ways:

- Between truck and BART Train which could be flat-bed, flat-bed on one side, or even closed on top such as those modified from retired BART cars.
- Between truck, solid platform, and BART Freight Train

The work of Bozicnik (2007) provides some possible alternatives for the consist-containers and transshipment solutions directly between BART train and Truck. This idea could also be applied to case for transshipment between truck, solid platform, and BART Freight Train. The idea has been adopted and preliminarily modified for our purpose. Basically, two ways can be used for moving container between BART car and the truck: (a) pushing over and roll-mat or ball-bearing floor; or (b) using a flexible hydraulic crane. Those two possible solutions will be discussed technically below.

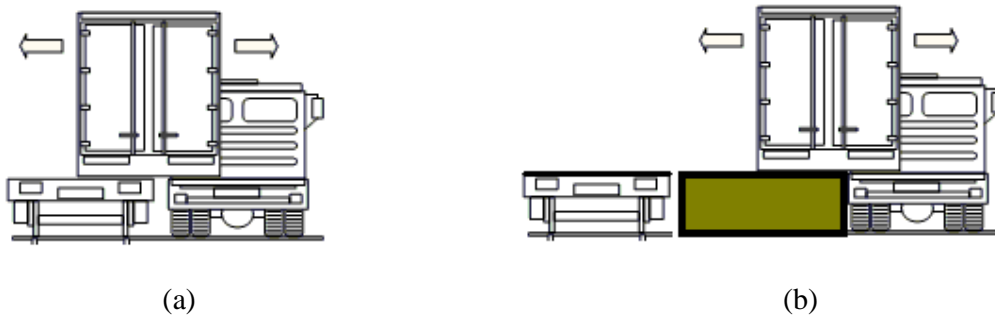

Figure 6-7. Truck-train Transshipment Solution 1: Directly Pushing if the roller-mat or ball-bearing (Figure 6-6) is installed on both BART car and the truck; (a) without a platform in between; (b) with a platform in between truck and BART car

Solution 1. As shown in Figure 6-7, if the roller-mat is installed on both truck and the flat bed BART car, the container could be directly pushed (as in the FedEx Sorting Center at OAK) by the operation staff between truck and BART provided that the truck can be parked very close to the train and they are at the same height. If not, an intermediate platform needs to be built to link the BART car and the truck. This is suitable even the transshipment truck is closed on top and on the two sides, in which case, this can be operated through back of the truck.

Solution 2. Using a Flexible Hydraulic Crane

A Flexible Hydraulic Crane is designed as in Figure 6-8. It is longitudinally movable along a rail on the platform. Besides, it is flexible in yaw motion, i.e. turning around between the truck and the BART car. It picks up the container from the train, turns 180° and put the container on the truck to finish the transshipment of one container. Then move longitudinally for one container length to do the next. Such process is completely reversible from truck to the train.

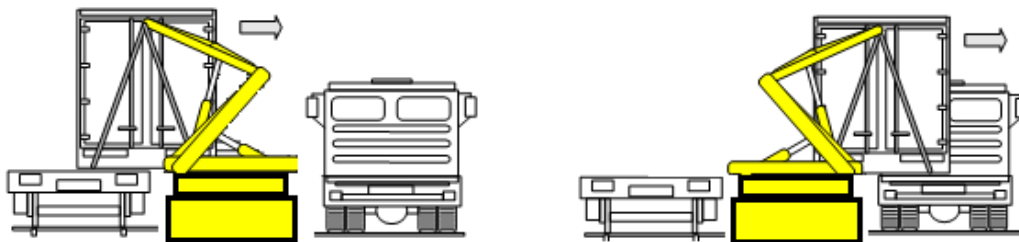

Figure 6-8. Side Loading Using Flexible Crane Mounted on Rail on the Platform

It is also possible to build a vehicle mounted crane which could move longitudinally between the truck and the BART car (Figure 6-9). The concept of operation would be the same as above. In this case, the platform in between the truck and BART would not be necessary.

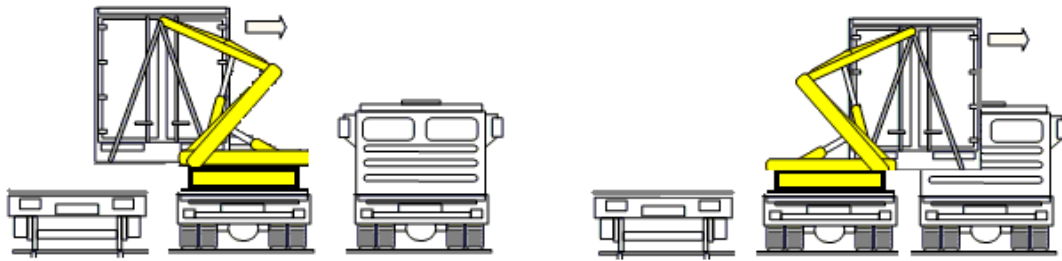

Figure 6-9. Side Loading Using a Flexible Crane on a Heavy-Duty-Vehicle

6.4 Summary

The main factors for infrastructure feasibility include:

- Compatibility between BART car and the containers subjected to the constraints of BART system operation requirement
- BART system access points
- Proximity of BART access points and the source of demand, in this case is the FedEx collection/distribution centers
- Transshipment between FedEx centers and BART access points

It has been shown that

Transshipment includes the following two main procedures: truck carries the container between FedEx center(s) and the access point; and moving container between BART car and the truck. For BART yard, shop and tail-track, truck can directly access the BART car. The transshipment can be accomplished by (a) pushing over on a roll-mat and ball-bearing; or (b) lifted with flexible hydraulic crane. It has already been showed that the transportation on BART, as well as the transshipment between truck and BART, is operationally feasible. Most of the necessary equipment, such as cars and rolling pads, are already available for modification and installation. Besides, additional infrastructure and equipment cost is manageable. However, the efficiency of the transshipment need needs further experiment to identify. The transshipment time is another critical factor for the success of the concept. It is expected that with better technology, reduced transshipment time can be achieved.

Chapter 7. Further Thoughts for Next Step

The presented analysis shows that the BART can be adopted as a reliable, social and environmental friendly mode of freight movement with a operationally feasible plan at an acceptable investment cost.

The improved reliability represents the benefit of FedEx from this project. The service of FedEx is very time sensitive, and thus improvement in the prediction of travel time can be quite beneficial. Through transporting on BART, FedEx can save the effort of rerouting during prompt events such as bay bridge closure, and avoid the risk of unexpected delay due to congestion.

The social impact analysis, especially the environmental impact, demonstrates the significant detrimental effect contributed by the current transportation mode, from the FedEx low priority goods in the bay area alone. This is also a clear indicator of the potential improvement by our proposed modification. At the same time, the scale of improvement is increasing with demand. Considering the current degrading of environmental condition, the improvement represents greater value increasing with time.

The modification can also promote people to switch to public transit mode, and hence improves freeway transportation efficiency, and provides alternative solution to congestion rather than freeway expansion. The saved investment can be given to the projects that are more urgent and more rewarding.

From the infrastructure point of view, a feasible scheme is readily operable, under a system-wise cost of about 260,000. Most of the necessary equipment involved, such as BART cars and rolling pads are existing ones, and the cost needed is only for the modification. In the future and with increasing freight demand, the modified retired cars will not suffice the demand, so we need to consider the design of new cars at this point. The low cost flat cars for freight movement can be an optimal design.

There are several future extensions to this study which will be pursued. Besides the refinement of the economics analysis, one critical issue is the potential demand lies in

manufacture and agricultural sectors. For example, there are agricultural products from central valley that are now going through Los Angeles airport due to the high inventory and operation cost of going through San Francisco airport. If this part of demand can utilize the service of the BART, the inventory cost can be reduced significantly. Another potential market lies in the expansion of the BART. The BART is planning to extend to San Jose by 2018. Considering the current high level of congestion on highway 880 and I80, the route through BART is very competitive in terms of travel time and level of service. In addition, the FedEx is going through some modification in bay area in April 2010, which involves more trucking inputs and more service frequency from SFO to OAK. Viewing from this, the demand involved in our analysis will be increasing, so does the benefit it generates.

As identified in of the previous study (Sivakumaran, 2009a, 2009b), major factors to the success of the concept for using BART for freight Movement subjected to the limit and funding for subsidy are: (a) adequate demand; (b) convenient access points in BART system by the freight carriers; and (c) the efficiency of transshipment. Of the three factors, the demand is most critical, which eventually determines the business case for BART. It is necessary to investigate further in those three aspects in the next phase of the project for a demonstration of the operational concept and/or for small scale operation.

Potential Demand for BART & Freight Movement

Potential demand for using BART for freight movement is unnecessarily to be restricted to air freight. Other industrial and agricultural products flowing around the Greater Bay Area such as those from high-tech manufacturers that could satisfy the safety and security standard of BART system are also potential demands. This could include products of electrical and electronics, biological, medical and others. The point is that, once it has been practically proved that BART system is capable of moving goods in the Greater Bay Area, other potentials could appear naturally.

As indicated in O'Connell and Mason (2007) and a recent discussion with the first author, California continues to export over one half-billion dollars in agricultural and other food

products by air each year, primarily to destinations in the Far East. Looking ahead, worldwide demand for high value-added food products of the sort produced in California is forecast to expand dramatically, especially in such fast-growing economies as China and India, where the ranks of upper middle-class consumers are rapidly expanding and where multinational food retailers are rapidly establishing a major market presence and are influencing the practices of indigenous food vendors. It identified the problem for airport ground access: In California, virtually all of the state's airborne foreign trade passes through just two gateways, Los Angeles International Airport (LAX) and San Francisco International Airport (SFO). The two airports have long maintained an effective monopoly over the state's foreign airborne trade. In 2006, for example, LAX and SFO together handled no less than 97.5 percent of all airborne international trade entering or leaving the state. The products are usually shipped first to the warehouse in the vicinity of SFO and stored there to wait for call if the flight is available. Since the warehouse rent is getting more expensive in recent years, many such exported agricultural air-cargo shipping shifted to LAX from SFO. Mr. O'Connell, the author of the report and a Consultant based at Sacramento, is interested in the concept of using BART system: to move the products to Pittsburg and/or Walnut Creek BART station which has direct line to SFO could possibility more profitable. The warehouse in those locations could be much cheaper. BART is a closed-operated system and meets with FAA's security consolidation, which may be another advantage to be a consolidated security company to bring the products into the airport. Besides, FedEx already has some shipping business for internationally exported agricultural products. In a long run, FedEx can also acts as the consolidated agency to take the products from BART system into the airport for their own flight or using other air cargo flight and they are experienced to do so.

BART Access Points

For Greater Bay Area collection and distribution of air freight products of both FedEx and UPS, to access BART at a nearest point to OAK is very critical. It is necessary to investigate the accessibility of BART shop and spur track at Oakland, as well Coliseum BART station. Arrangement are underway for a site visit to those points.

Beside the BART access points for local collection and distribution, there is a significant

demand between the three international airports: SFO, OAK and SJC. As indicated by FedEx, the freight movement between the three airports is an important part of their business due to air flight arrangement and products from/to other air cargo carriers. FedEx has strong interest in BART link to San Jose since this could be a very potential mode for moving their products between the airports instead of using truck on the congested freeway corridors Highway 101 and Interstate I-880.

Practical Equipment for Demo and Small Scale Operation

The transshipment equipment needs to be practically identified for demo and small scale operation. Due to the new FedEx flight, from OAK to Tokyo, it will require overnight delivery from SFO to OAK, which could start as early as in April 2010. As indicated by FedEx manager, this could be a chance for demo or small scale operation. However, it is necessary to identify practical equipment for transshipment and convenient access points to BART system. For SFO side, BART Millbrae Station or the redundant platform at SFO international terminal are possible alternatives.

To Improve Economic Analysis of Previous Report

It is still necessary to improve the economic analysis in previous phase report. The following are some suggestions by FedEx:

- Find load capacity per sq. foot for BART floors, since all of the weight of FedEx USPS containers will be on wheels, which is important in the specification BART car for container movement.
- Add Emeryville Distribution Center to list of possible FedEx sites connected to BART which was missed in previous analysis.
- Include low-emissions heavy duty trucks or Electric Vehicle (EV) in analysis: Ongoing projects are being carried on to develop bigger EV trucks, which can provide a transshipment alternative for our project. FedEx is also interested in using “green” trucks, such as low-emissions trucks for transshipments.

These results should be of particular interest to other urban areas such as Los

Angles, Washington D. C., New York and Chicago across the U.S. where passenger rail systems exist in close proximity to major air cargo terminals. Some of these systems may possess particularly favorable characteristics towards mixed-goods movement, such as intermodal transfer stations, containers which can interface between multiple modes, and standard gauge rails.

Reference

- Bay Area Rapid Transit (BART) (2009). *BART Trip Planner*. www.bart.gov/. Accessed April 19
- Bozicnik, S., (2007), New Innovative Intermodal Rail Freight Paradigm, Proc. of 11th World Conference on Transport Research, Berkeley, June 24-28
- Delucchi, M. (2000). "Environmental Externalities of Motor-Vehicle Use in the US." *Journal of Transport Economics and Policy* **34**(2): 135-168
- ICF International (2009), Final Report: Comparative Evaluation of Rail and Truck Fuel Efficiency on Competitive Corridors, Federal Railroad Administration;
- Holguin-Veras, J., (2009a), Urban Delivery Industry Response to Cordon Pricing, Time-Distance Pricing, and Carrier-Receiver Policies; 3rd National Urban Freight Conference, Oct. 21-23, 2009, Long Beach, California.
- Holguin-Veras, J., (2009b), Approximation Model to Estimate Joint Market Share in Off-hour Deliveries; TRB 89th Annual Meeting, Washington D. C., Jan. 10-14, 2010,
- Lu, X. Y., Hanson, M., Graham, M., Nishinaga, G., and Lu, R. (2007), Investigating the possibility of using BART for air freight movement, Proc. of the 2nd National Urban Freight Conference, Long Beach, LA, December
- Maes, J., and Thierry Vanelander, J.,(2009), The use of rail transport as part of the supply chain in an urban logistics context, METRAN National Urban Freight Conference
- Matches, Elevator Cost Estimator, <http://www.matche.com/EquipCost/Elevator.htm>, Accessed Dec, 2009
- Metropolitan Transportation Commission (MTC) (2004). *Regional Goods Movement Study for the San Francisco Bay Area: Final Summary Report*
- Metropolitan Transportation Commission, (2008a). *Change In Motion: Transportation 2035 Plan for the Bay Area*
- Metropolitan Transportation Commission, (2008b), *Travel Forecasts Data Summary: Transportation 2035 Plan for the Bay Area*.
- Nuzzolo, A., Crisalli, U., Comi, A., and Sciangula, F., (2007), Metropolitan Freight Distribution by Railway: A Methodology to Support the Feasibility Analysis, METRAN

- National Urban Freight Conference B3-886;
- O'Connell, J., and Mason, B., (2007), *The Role of Air Cargo in California's Agricultural Export Trade: A 2007 Update*; Center for Agricultural Business, California Agricultural Technology Institute, California State University, Fresno, CATI Pub. #070801
- Office of Transportation and Air Quality (2008), *Calculating Greenhouse Gas Emissions: Key Facts and Figures*. United States Environmental Protection Agency.
- Oxford Economic Research Associates (1999), *The Environmental and Social Costs of Heavy Goods Vehicles and Options for Reforming the Fiscal Regime*, English, Welsh, and Scottish Railway, (www.ews-railway.co.uk)
- Paaswell R., Herbert Levinson, Eickemeyer P., and Benjamin Miller, B., Schwartz,H., and Zerkin, A., J., (2009), Issues in Siting of a Truck Rail Intermodal Facility, *3rd National Urban Freight Conference*, Oct. 21-23, 2009, Long Beach, California.
- Sivakumaran, K., Lu, X. Y., Hanson, M., Lu, R., Zaman, F. and Zhou, R., (2009a), The Use of Passenger Transit Infrastructure for Goods Movement: A Bay Area Economic Feasibility Study, CD ROM of 3rd National Urban Freight Conference Long Beach, CA, October 21-23
- Sivakumaran, K., Lu, X. Y., Rai, R., and Wang, R., (2009b), The Potential of Using Transit Infrastructure for Air Freight Movement: A Case Study in the Bay Area, PATH Year One Report, Project sponsored by UCTC and Caltrans, Dec. 14
- Sivakumaran, K., Lu, X. Y., and Hanson, M., (2010), The Use of Passenger Transit Infrastructure for Goods Movement: A Bay Area Economic Feasibility Study, CD ROM of 89th TRB Annual Meeting, Washington D. C., Jan.10-14, 2010; *Transportation Research Record*, No. 2162, p44-52
- The California Energy Commission (2007): *Transportation Energy Forecasts for the 2007 integrated energy policy report*
- The California Energy Commission (2009): *California Energy Resources*
- Vromansa, M., Dekkerb, R. and Kroonc, L. G., (2006), European Journal of Operational Research, Vol. 172, no. 2, p647-665
- Wei, W. (2009), Exploration of Data Resources for Air Cargo Studies, MINETA

Other Literatures

FHWA (1995), Comprehensive Truck Size and Weight Study, Summary Report, Phase I - Synthesis of Truck Size and Weight (TS&W) Studies and Issues, Federal Highway Administration, March, available at: <http://ntl.bts.gov/DOCS/cts.html>

FMCSA (2009), *Motor Carrier Safety Progress Report*. Federal Motor Carrier Safety Administration, Accessed July 27, Website:

<http://www.fmcsa.dot.gov/facts-research/facts-figures/analysis-statistics/cmvmfacts.htm/>.,

National Transit Database (2009). *San Francisco Bay Area Rapid Transit District (BART)*. Accessed July 31

Parry, Ian. (2008), How should heavy-duty trucks be taxed? *Journal of Urban Economics*. Vol. 63, Issue 2, pp. 651-668.

PayScale. *Median Hourly Rate by Job, Employer: FedEx/FedEx Express Corporation*. www.payscale.com/research/US/Employer=FedEx/_Federal_Express_Corporation/Hourly_Rate>. Accessed July 29, 2009.

Small, K., et al (1999), *Valuation of Travel-Time Savings and Predictability in Congested Conditions for Highway User-Cost Estimation*, NCHRP 431, TRB

Small, K., Winston, C., and Yan, J. (2005), *Uncovering the Distribution of Motorists' Preferences for Travel Time and Reliability: Implications for Road Pricing*, Working Paper, Department of Economics, University of Irvine

Transportation Research Board (1998), Committee for Study of Policy Options to Address Intermodal Freight Transportation, *Policy Options for Intermodal Freight Transportation*, Transportation Research Board