

Lawrence Berkeley National Laboratory

Recent Work

Title

ESCA RESULTS VERSUS OTHER PHYSICAL AND CHEMICAL DATA

Permalink

<https://escholarship.org/uc/item/80m21158>

Author

Shirley, D.A.

Publication Date

1974-02-01

Presented at the International Conference
on Electron Spectroscopy, Namur, Belgium,
April 16-19, 1974

LBL-2397

c. j.

ESCA RESULTS VERSUS OTHER PHYSICAL AND
CHEMICAL DATA

D. A. Shirley

February, 1974

Prepared for the U. S. Atomic Energy Commission
under Contract W-7405-ENG-48

TWO-WEEK LOAN COPY

*This is a Library Circulating Copy
which may be borrowed for two weeks.
For a personal retention copy, call
Tech. Info. Division, Ext. 5545*

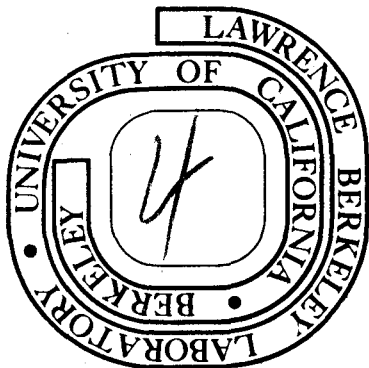

LBL-2397

c. j.

DISCLAIMER

This document was prepared as an account of work sponsored by the United States Government. While this document is believed to contain correct information, neither the United States Government nor any agency thereof, nor the Regents of the University of California, nor any of their employees, makes any warranty, express or implied, or assumes any legal responsibility for the accuracy, completeness, or usefulness of any information, apparatus, product, or process disclosed, or represents that its use would not infringe privately owned rights. Reference herein to any specific commercial product, process, or service by its trade name, trademark, manufacturer, or otherwise, does not necessarily constitute or imply its endorsement, recommendation, or favoring by the United States Government or any agency thereof, or the Regents of the University of California. The views and opinions of authors expressed herein do not necessarily state or reflect those of the United States Government or any agency thereof or the Regents of the University of California.

ESCA RESULTS VERSUS OTHER PHYSICAL AND CHEMICAL DATA*

D. A. SHIRLEY

Department of Chemistry and Lawrence Berkeley Laboratory, University of California, Berkeley, California 94720 (U.S.A.)

SUMMARY

X-ray photoemission spectra yield quantities of very direct interest in physics and chemistry. In this paper the relations of these spectra to other data and concepts are discussed. Both initial-state and final-state properties may be studied: the former are treated first. Charge distributions in molecules alter the effective (Coulomb plus exchange) potential experienced by core electrons in molecular ground states, thereby shifting their binding energies. The shifts can be calculated by ab initio methods or more directly by using potential models based on intermediate-level molecular-orbital theories such as INDO. One version, the ground-state potential model (GPM) yields good predictions of core-level shifts among atoms in similar environments. Alternatively, the measured shifts may be used to derive charges on individual atoms in molecules. It is more difficult to derive charges in solids in this way, but a characteristic splitting in the more tightly-bound valence bands yields a direct measure of ionicity in simple binary compounds of the zinc-blende and rock-salt structures. Atomic orbital composition of molecular orbitals can be deduced from photoemission spectra. In solids such as diamond and graphite comparison of photoemission spectra with x-ray emission spectra yields the atomic-orbital composition of the valence bands. Turning to final-state properties, the spectra are dominated by relaxation effects. Again a simple approach--the relaxation potential model (RPM)--predicts core-level shifts well for cases in which the atomic environments are varied substantially. Among ammonia and the methylamines, for example, the N(1s) shifts are predicted correctly by RPM, while GPM reverses the order. For paramagnetic molecules RPM predicts electron charge transfer toward the positive hole but usually spin transfer away, in agreement with experiment. Extra-atomic relaxation in metals, a many-body effect, is manifest both as a contribution to the binding energy and as line-shape asymmetry. Delocalized valence

*Work performed under the auspices of the U. S. Atomic Energy Commission.

electrons also show relaxation shifts that can be understood as polarization of the electron gas toward the "Coulomb hole". Auger lines show larger relaxation shifts. Comparison of core-level or Auger shifts in nonmetallic solids separately is questionable because there is no reference level, but intercomparison of the two is meaningful. Finally, core-level binding-energy trends in series of simple alcohols, etc., agree quantitatively with proton affinities and core-level shifts in other functional groups. This suggests extending the concept of Lewis basicity to include lone pairs of core electrons. Thus, core-level shifts measure the chemical reactivity--a quantity of great chemical importance that depends on both initial- and final-state properties--rather directly. Relaxation energies are shown to be the dominant cause of trends in the lowest ionization potentials of simple alcohols and amines.

INTRODUCTION

There comes a time in the evolution of any experimental method when its advocates must face squarely the question of whether they are studying the method itself or are in fact using it to improve their understanding of physical systems. Stated succinctly, we might ask, "Do we use our spectra to explain chemistry, or vice-versa?" In a surprising number of instances the latter alternative is the correct one. Perhaps one of the most appealing features of x-ray photoemission (ESCA) is that the spectra provided by this method often yield definitive information about the structure of matter, and it passes the above test with ease. The reason is that binding energies are themselves quantities of great physical interest, and they are closely related to the most important chemical properties of molecules and solids. X-ray photoemission studies in our laboratory have focused on the relation between binding energies of core and valence orbitals in molecules and solids and other quantities of chemical and physical interest. In this paper we shall briefly discuss some of these relationships. More detailed discussions can be found in separate publications referred to in the text.

In organizing the discussion below we have eschewed making an artificial division between studies of molecules and those of solids. It seems more important to distinguish between approaches that yield information about initial- (or ground-) state properties and those that pertain to final- (or excited-) state effects. The former include particularly charge distributions in molecules or solids (called inductive effects in chemistry)

while the latter involve charge transfer and relaxation toward hole states (the chemist's "polarization effects"). Although the two approaches are not rigorously separable, it is conceptually advantageous to treat them individually. We do so in the two sections below. At the end of the last section it is argued that a quantity of great chemical interest--the reactivity--is actually related to a combination of inductive and polarization effects.

INITIAL-STATE PROPERTIES

One of the most useful features of core-level binding-energy shifts (ESCA shifts) is that they are sensitive to charge distributions in molecules. This rather obvious fact was discovered independently by several groups, and it was later generally appreciated that earlier versions of most of the physical effects responsible for these shifts had already been worked out to explain shifts in x-ray energies. Rigorous calculations of shifts in core-level orbital energies in molecules were given by Basch and Snyder [1], while Schwartz [2] first calculated binding energies of core-level states in molecules based on total energy differences. Other early work has been reviewed previously [3].

In addition to these ab initio approaches, other less rigorous methods have been developed that depend more directly on physical intuition. These are generally known as potential model approaches, in which core-level binding-energy shifts, δE_B , are equated to the changes in the effective electrostatic potential energies experienced by the core orbitals,

$$\delta E_B^i = -\delta V^i \quad [1]$$

Here V^i is the potential energy of orbital i . A further approximation is usually made: the potential energy at the nucleus is used. This is valid because core levels are strongly localized.

Several groups discovered potential models independently, and several versions exist. The version that is favored in our laboratory employs CNDO wavefunctions but evaluates r^{-1} integrals explicitly rather than using the point-charge approximation. It also corrects for the dependence of r^{-1} integrals involving other-center p orbitals on the choice of coordinate axes. This gives the "GPM" (ground-state potential model) approach, developed with Davis [4].

The advantages of the GPM theory are: (1) It can be used by any chemist, because the calculations are simple and inexpensive, and (2) It provides excellent predictions of δE_B within groups of similar molecules (i.e. similar size and local environment). Disadvantages are: (1) The GPM theory has only been shown to work for second-row elements. Extension to transition metals, for example, would require further parameterization of the CNDO theory, and (2) It fails when binding energies of core orbitals in very different molecules are compared, as discussed in the next section.

Figure 1 shows theoretical δE_B (C 1s) values from GPM calculations plotted against experimental results, for gaseous fluorinated methanes [5] and ethanes [6]. In all these molecules the carbon atoms are tetrahedrally coordinated and--except for methane itself--the agreement with theory is excellent: better than 0.2 eV in most cases.

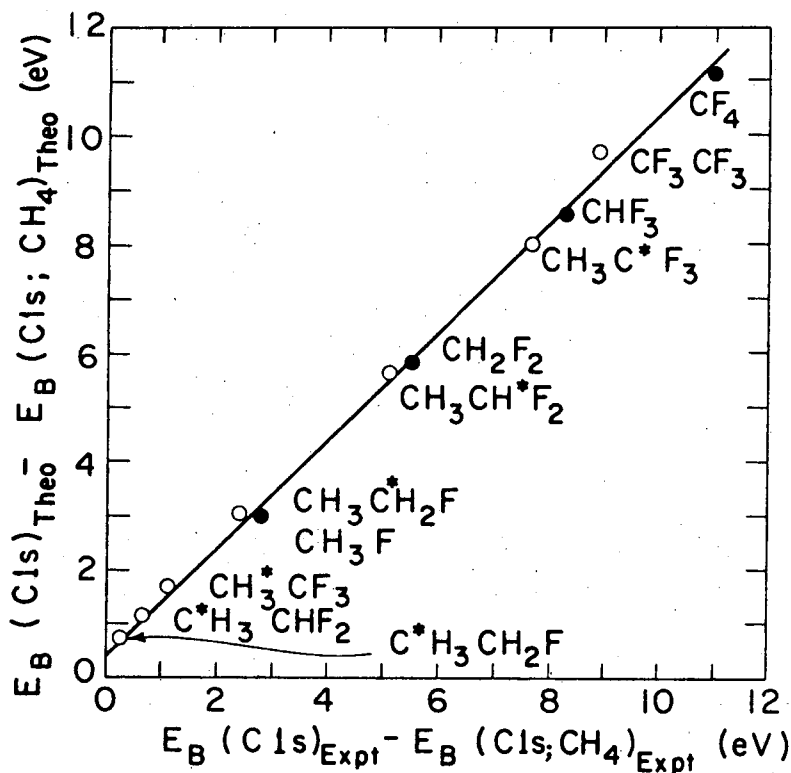

Fig. 1. Theoretical versus experimental C(1s) binding energy shifts for fluorinated methanes (filled circles) and ethanes (open circles). The experiments were performed on gaseous molecules. Theoretical points were calculated using the GPM formalism. The line has unit slope (References [4-6]).

Although the successes of potential models are gratifying, they tend to fall under the heading of predicting spectra from chemistry. It is more exciting to invert the potential models and use measured shifts to deduce

charge distributions. Again such approaches were developed independently by several groups. Three rather fully-developed, very similar applications have appeared recently [7-9]. In our version, called ACHARGE (for atomic charge) a set of linear equations relates shifts to atomic charges,

$$\vec{\delta} = A \vec{q} \quad . \quad [2]$$

The matrix A is deduced from molecular geometry and atomic constants, but no molecular-orbital models are involved. Insertion of experimental values for the components of $\vec{\delta}$ and solution of the equations yields a set of atomic charges \vec{q} that tend to agree very well with CNDO results. Of special interest is a "charge alternation" effect observed on fluorine substitution in hydrocarbons: the alpha carbon appears to take on a small negative charge. This effect is observed in ethane, ethylene, and benzene, as indicated in Fig. 2. The agreement between theory and experiment is gratifying, but it should be noted that both CNDO and ACHARGE potentials are essentially based on point-charge models, and "charge alternation" may be partly an artifact of this common approximation.

MOLECULE	Q(C*)	
	EXPT.	THEO.
H ₃ C* - CH ₂ F	-0.02	-0.04
H ₃ C* - CHF ₂	-0.05	-0.08
H ₃ C* - CF ₃	-0.09	-0.11
H ₂ C* = CHF	-0.05	-0.11
H ₂ C* = CF ₂	-0.14	-0.18
C ₆ H ₅ F, ortho C*	-0.04	-0.05

Fig. 2. Derived charges on carbons in alpha position on fluorine substitutions, relative to unsubstituted case. Experimental values are from the ACHARGE analysis, and theoretical values are from CNDO calculations (References [6 and 7]).

The deduction of atomic charges in solids from core-level shifts is very elusive. Although we suggested this possibility very early [10], we are now very skeptical of this approach. The shifts are small, there is no suitable reference level, and relaxation effects may be important. A much more promising approach lies in analysis of the most tightly-bound valence orbitals in simple solids. For binary solids such as the III-V and II-VI compounds the second and third valence peaks are separated by an "antisymmetric gap" that is closely related to the ionicity [11]. Figure 3 shows a plot of the measured gap [11,12] versus Phillips' ionicity [13] for a series of compounds. We are currently engaged in developing an ionicity scale based on the antisymmetric gap for a wide range of compounds.

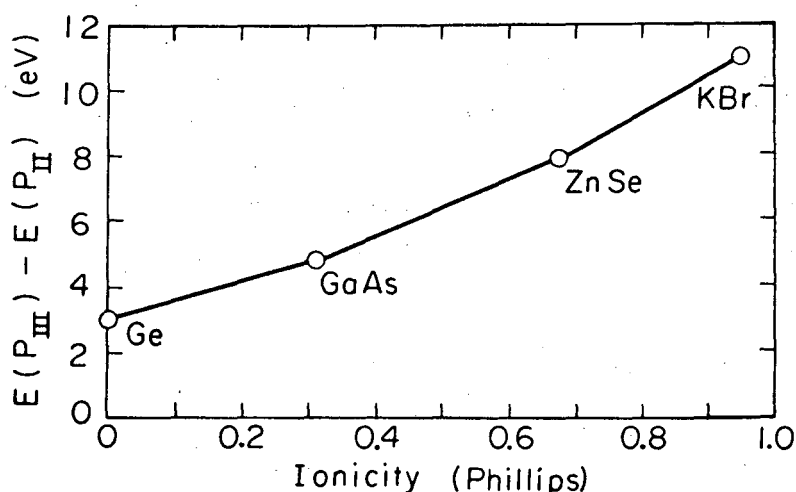

Fig. 3. Splitting between second and third valence-band peaks in Ge and in III-V, II-VI, and I-VII compounds, versus Phillips' ionicity (References [11-13]).

In an earlier conference Price [14] and Gelius [15] independently showed the connection between atomic orbital composition and intensity variation in molecular-orbital photoemission spectra. Manne [16] has discussed the comparison of x-ray photoemission (XPS) and x-ray emission (XES) spectra. By combining these ideas and applying them to solids, we have been able to deduce the atomic-orbital compositions of diamond and graphite [17]. The diamond case is illustrated in Fig. 4, in which XES [18] and XPS [17] spectra of the valence bands are plotted together with the theoretical density of states, $\rho(E)$ [19]. Because the XPS cross section ratio favors the 2s state ($\sigma(2s)/\sigma(2p) \cong 13$) while K x-ray emission from the 2s level is strictly forbidden, the XPS spectrum is most intense for the more tightly-bound s bands, and the p bands are emphasized in the XES

spectrum. Analysis of the two simultaneously and comparison with $\rho(E)$ yields the fractional p character, shown in the lower panel of Fig. 4.

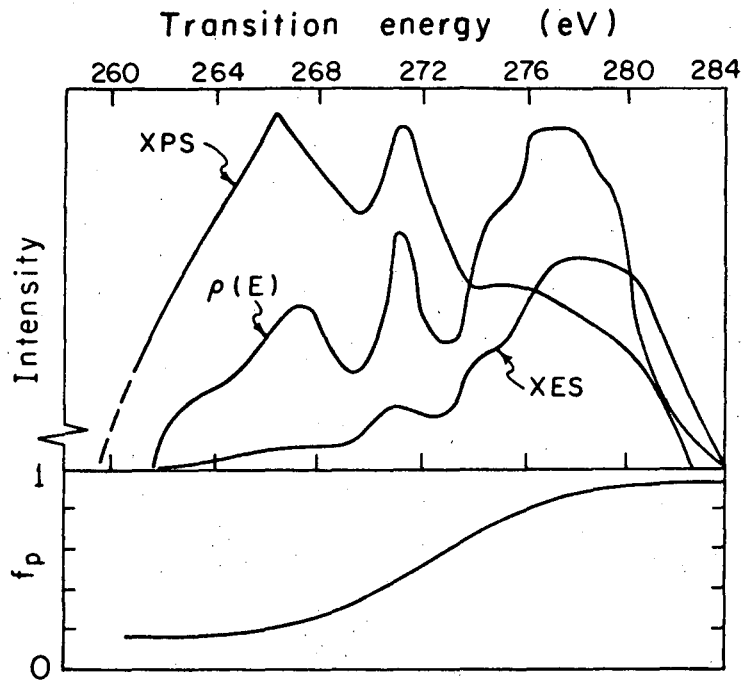

Fig. 4. Top: valence band density-of-states (Reference [19]), K x-ray emission spectrum (Reference [18]), and x-ray photoemission spectrum of diamond (Reference [17]). Bottom: derived fractional p character throughout the valence band.

FINAL STATE PROPERTIES

Photoemission is in one sense a one-electron process, but in a more profound sense many electrons are involved. The "passive" electrons that remain behind in a photoexcited atom, molecule, or solid are polarized toward the hole during photoemission (i.e. adiabatically), thus reducing the binding energy. This effect is expressed as a relaxation energy (also termed polarization or reorganization energy), E_R , and the binding energy is related to the one-electron orbital energy ϵ by

$$E_B = |\epsilon| - E_R \quad [3]$$

Clearly if two molecular environments are compared,

$$\delta E_B = \delta |\epsilon| - \delta E_R \quad [4]$$

The GPM model discussed above will work best in comparing similar molecular environments, for which E_R can be neglected, and for such cases shifts in

binding energy can properly be interpreted as measuring ground-state properties. When comparing molecules for which the ground-state properties (inductive effects) vary little ($\delta|\epsilon| \approx 0$), variations in relaxation energy may even dominate δE_B . A prototypical case in which this occurs is the series ammonia, methylamine, dimethylamine, trimethylamine. Experiment shows $E_B(N\ 1s)$ decreasing with increasing substitution [20], while chemical arguments would predict an increase in E_B because the methyl groups should be slightly electron-withdrawing in the ground state (an inductive effect). In fact the GPM model predicts an increasing E_B , in contradiction to experiment. The explanation of this dilemma is that final-state relaxation allows a methyl group to contribute much more electron density to the hole state than can a hydrogen ligand, and the δE_R term in Eq. (4) is larger by about a factor of 2 than the $\delta|\epsilon|$ term. The RPM model [4], which is based on CNDO wavefunctions and includes final-state relaxation, predicts the shifts quite accurately [6], as shown in Fig. 5.

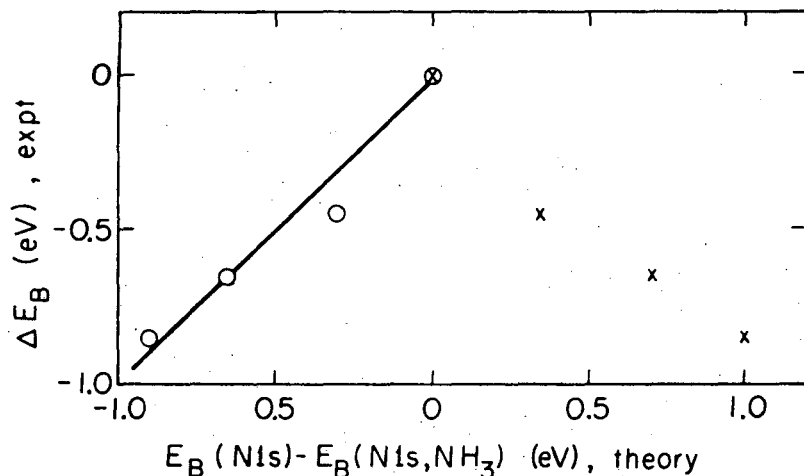

Fig. 5. Relative experimental vs theoretical N 1s binding energies for the molecules (from top): NH_3 , CH_3NH_2 , $(CH_3)_2NH$, $(CH_3)_3N$. Note that RPM theory (open circles) predicts shifts very well, while GPM predictions (x's) go in the wrong direction (References [6 and 20]).

Electron polarization during photoemission has a very important effect on multiplet splitting in small paramagnetic molecules. Early work led to the expectation that this splitting could be used directly to determine unpaired spin distribution in molecules. However RPM calculations together with experiments on a number of molecules show that, as electronic charge moves toward the core hole in bonding orbitals, the unpaired valence-electron spin (which is usually in antibonding orbitals) moves away,

reducing the multiplet splitting [21].

Extra-atomic relaxation is always a large effect for core levels in metals. Core-level binding energies in metals are always smaller than in free atoms. The difference can be described in terms of "screening" of the core hole-state charge by polarization of itinerant valence-band electrons, forming a "semi-localized exciton" [22]. Such exciton states are well-known in alloy theory and x-ray emission theory [23], but photo-emission provides very direct evidence for them. In the 3d group, for example, the extra-atomic relaxation energy should drop dramatically between nickel and copper, as d-wave screening becomes much less important. This can be understood semiquantitatively if the relaxation energy of, e.g., a 2s orbital is estimated from atomic integrals as [22]

$$\Delta E_{ea} \cong \frac{1}{2} F^0(2s \ 3d) \sim 18 \text{ eV}$$

or

$$\frac{1}{2} F^0(2s \ 4s) \sim 5 \text{ eV} ,$$

with the choice depending on whether or not the 3d shell is open. A plot of the difference $E_B(2s, \text{atomic}) - E_B(2s, \text{metal; vacuum-level reference})$ against Z for the 3d metals shows that the expected drop is indeed observed (Fig. 6).

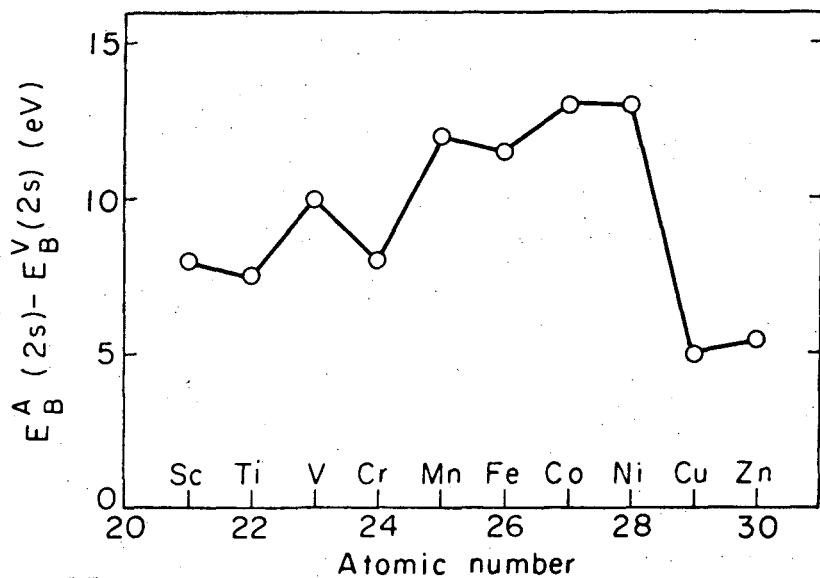

Fig. 6. Difference between binding energies of 2s orbitals in free atoms and metals (relative to the vacuum level) for the 3d series. Binding energies are lowered most in metals for which d-wave screening yields large extra-atomic relaxation energies: hence the dramatic drop between nickel (d^8 or d^9) and copper (d^{10}) (Reference [22]).

Reduction in valence-electron binding energies relative to those in free atoms has been understood since Wigner and Bardeen [24] calculated the work function, ϕ . They used a free-electron model and carried out the calculation in a way that is a little difficult to relate to Hartree-Fock calculations on molecules, for example. Because the valence electrons were delocalized in the initial state in their model, it is far from obvious how the reduction in the valence-electron binding energies in metals relative to their atomic counterparts is related to the semilocalized exciton model for core hole states. The relation must of course be very close, by continuity arguments. In fact we have found that one can also predict a reasonable value of ϕ by assuming the valence-band hole state to be localized, and using the exciton model. This yields

$$\phi \cong E_C + E_B^A - \frac{1}{2} F^0(v,v) - \Delta E_{VB} \quad , \quad [5]$$

where E_C is the cohesive energy and ΔE_{VB} is the energy difference between the average valence-band energy and the Fermi edge. An energy-level diagram is shown in Fig. 7. This approach yields an estimate of $\phi \sim 2.4$ eV for sodium, in good agreement with both experiment (2.3 eV) and the itinerant-electron-model value (2.2 eV). The reason for this agreement is not hard to discover. Comparison of Eq. (5) with the Wigner-Bardeen expression shows a 1-1 correspondence with their larger terms (exchange and correlation terms are easily added to Eq. (5)). We may understand this similarity if we regard their model in terms of the screening of an itinerant "Coulomb hole" in the final state, rather than a localized hole. Since the Wigner-Seitz sphere is about the same size as a localized atom, the screening energies are very similar in size and are largely independent of the degree of localization.

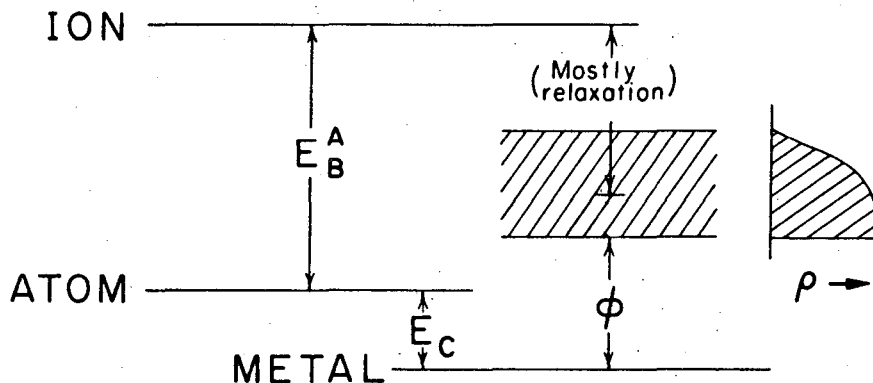

Fig. 7. Comparison of valence-electron binding energies in free atoms and metals. The average binding energy in the metal is slightly larger than the work function ϕ , but considerably lower than the free-atom value E_B^A . The difference arises largely through screening of the localized or itinerant Coulomb hole.

Screening energies are even larger for Auger transitions in metals, because there are two holes in the final state [25,26]. Again a semi-localized exciton model is applicable, and multiplet structure shows clearly that the final state is indeed localized, even for LMM spectra in copper, for example [26]. Two useful results emerge from this analysis. First, Auger shifts arise largely through final-state relaxation effects, not chemical effects. Second, while neither Auger- nor binding-energy shifts among solids can be interpreted quantitatively without knowledge of the work functions, the effect of ϕ cancels out if the two are compared. Figure 8 shows a comparison for sodium.

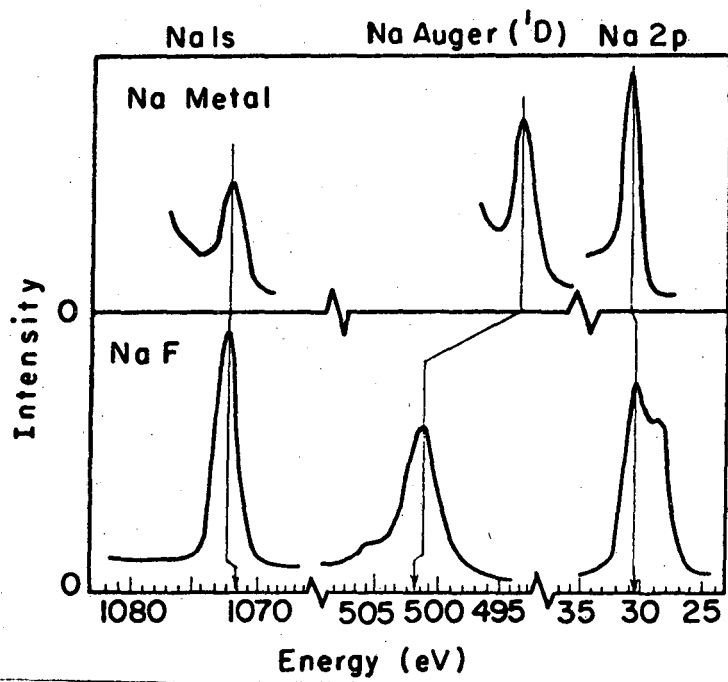

Fig. 8. Comparison of binding-energy and Auger shifts in sodium, NaF, and free sodium atoms (arrows at bottom). The K x-ray energy (i.e., 1s-2p) is nearly constant throughout, and shifts between atomic sodium and NaF are small, in spite of a change in charge state. Extra-atomic relaxation gives a relative shift of 8 eV in the Auger line for the metal (Reference [26]).

Returning now to molecules, we note that there is a very strong resemblance between certain ESCA shifts and chemical reactions [27]. For example in simple alcohols both the proton attachment reaction



and the O 1s ionization reaction



can be viewed as the addition of a positive point charge to the oxygen atom. In one case this charge goes into the proton position, in the other near the oxygen nucleus. The shifts in the energies of these two reactions should vary similarly as the R group is changed. Both shifts depend on initial-state (inductive) effects and on final-state (polarization) effects in similar ways. This suggests that the relation

$$\delta E_B(\text{O } 1s) \cong -\delta(\text{PA}) \quad [8]$$

should be obeyed, where PA is the proton affinity in Eq. (6). That Eq. (8) is obeyed for a series of "simple" alcohols is shown in Fig. 9.

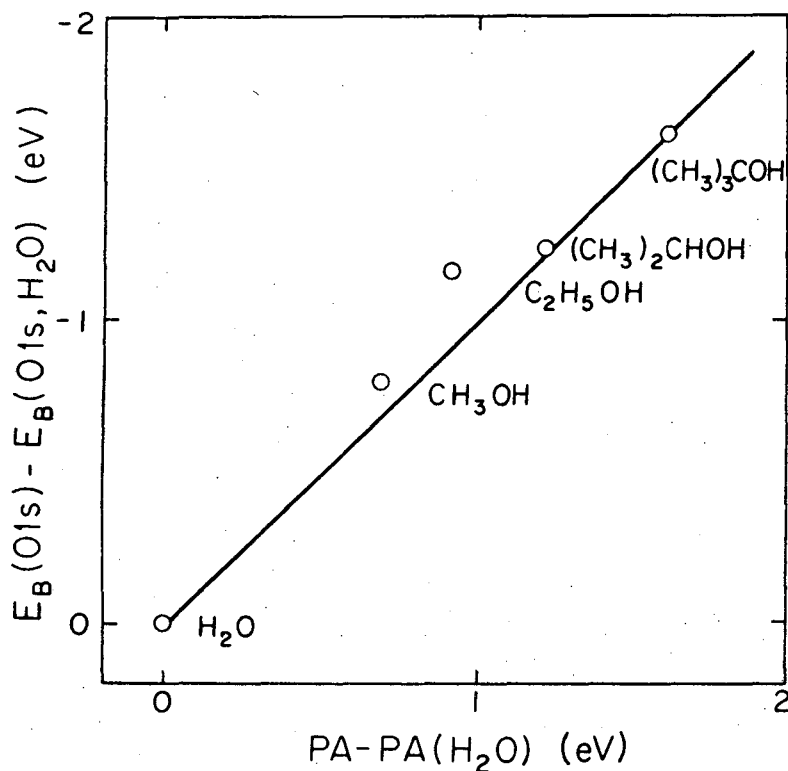

Fig. 9. Comparison of O 1s binding-energy shifts with proton affinities for simple alcohols (both in the gas phase). The line has unit slope (Reference [27]).

These concepts can be applied beyond comparison with proton attachment reactions if we generalize the concept of Lewis basicity to include lone pairs of core electrons. ESCA shifts are then seen to give a rather direct measure of changes in basicity of functional groups. This is tantamount to a measure of the chemical reactivity, at least for reactions with electrophilic reagents. Thus we find that while δE_B depends on both initial- and final-state effects, so also does the reactivity, and in the same way.

This is a positive feature of ESCA shifts, because the reactivity is, after all, the quantity of real interest to the chemist.

Finally we observe that these arguments apply with nearly equal force to lone pairs in valence orbitals. To the extent that the first ionization potential (IP_1) is truly associated with a lone-pair orbital, shifts in IP_1 should arise mostly from final state relaxation effects, in contrast to the usual explanations. In fact shifts in IP_1 in simple alcohols and amines agree very well with RPM estimates of the relaxation energies alone [27].

ACKNOWLEDGMENTS

This paper has given a capsule summary of some of the main ideas developed in our laboratory during the last two years. Most of this work will be, or has been, published in greater detail elsewhere. The "we" in this paper is not a euphemism for "I", but represents contributions in various combinations from the author's co-workers: Dr. L. Ley, Mssrs. M. S. Banna, D. W. Davis, S. P. Kowalczyk, R. L. Martin, F. R. McFeely, and R. A. Pollak. Their contributions are gratefully acknowledged.

REFERENCES

- 1 H. Basch and L. C. Snyder, *Chem. Phys. Letters*, 3(1969)333.
- 2 M. E. Schwartz, *Chem. Phys. Letters*, 5(1970)50.
- 3 D. A. Shirley, in I. Prigogine and Stuart A. Rice (Editors), *Advances in Chemical Physics*, Vol. 23, John Wiley and Sons, 1973, p. 85.
- 4 D. W. Davis and D. A. Shirley, *J. Electr. Spectrosc.*, 3(1974)137.
- 5 T. D. Thomas, *J. Am. Chem. Soc.*, 92(1970)4184.
- 6 D. W. Davis, M. S. Banna, and D. A. Shirley, *J. Chem. Phys.*, 60(1974)237.
- 7 D. W. Davis, D. A. Shirley, and T. D. Thomas, *J. Am. Chem. Soc.*, 94(1972)6565.
- 8 G. D. Stucky, D. A. Matthews, J. Hedman, M. Klasson, and C. Nordling, *J. Am. Chem. Soc.*, 94(1972)8009.
- 9 D. T. Clark, D. B. Adams, and D. Kilcast, *Chem. Phys. Letters*, 13(1972)439.
- 10 C. S. Fadley, S. B. M. Hagström, M. P. Klein, and D. A. Shirley, *J. Chem. Phys.*, 48(1968)3779.
- 11 R. A. Pollak, L. Ley, S. Kowalczyk, D. A. Shirley, J. D. Joannopoulos, D. J. Chadi, and M. L. Cohen, *Phys. Rev. Letters*, 29(1972)1103.

- 12 S. P. Kowalczyk, F. R. McFeely, L. Ley, R. A. Pollak, and D. A. Shirley, *Phys. Rev. B*, in press, June, 1974.
- 13 J. C. Phillips, *Rev. Mod. Phys.*, 42(1970)317.
- 14 W. C. Price, A. W. Potts, and D. G. Streets, in D. A. Shirley (Editor), *Electron Spectroscopy*, North-Holland, 1972, p. 187.
- 15 U. Gelius, *ibid.*, p. 311.
- 16 R. Manne, *J. Chem. Phys.*, 52(1970)5733.
- 17 F. R. McFeely, S. P. Kowalczyk, L. Ley, R. G. Cavell, R. A. Pollak, and D. A. Shirley, *Phys. Rev. B*, in press, 1974.
- 18 G. Weich and E. Zöpf, in *Electronic Density of States*, Nat. Bur. Std. Special Publication 323, 1969, p. 335.
- 19 G. S. Painter, D. E. Ellis, and A. R. Lubinsky, *Phys. Rev.*, B4(1971)3610.
- 20 P. Finn, R. K. Pearson, J. M. Hollander, and W. L. Jolly, *Inorg. Chem.*, 10(1971)378.
- 21 D. W. Davis, R. L. Martin, M. S. Banna, and D. A. Shirley, *J. Chem. Phys.*, 59(1974)4235.
- 22 L. Ley, S. P. Kowalczyk, F. R. McFeely, R. A. Pollak, and D. A. Shirley, *Phys. Rev.*, B8(1973)2392.
- 23 J. Friedel, *Phil. Mag.*, 43(1952)153; *Advan. Phys.*, 3(1954)446.
- 24 E. Wigner and J. Bardeen, *Phys. Rev.*, 48(1935)84.
- 25 C. D. Wagner and P. Biloen, *Surface Sci.*, 35(1973)82.
- 26 S. P. Kowalczyk, L. Ley, F. R. McFeely, R. A. Pollak, and D. A. Shirley, *Phys. Rev. B*, in press, 1974.
- 27 R. L. Martin and D. A. Shirley, Lawrence Berkeley Laboratory Report LBL-2341, December, 1973, in press, 1974.

LEGAL NOTICE

This report was prepared as an account of work sponsored by the United States Government. Neither the United States nor the United States Atomic Energy Commission, nor any of their employees, nor any of their contractors, subcontractors, or their employees, makes any warranty, express or implied, or assumes any legal liability or responsibility for the accuracy, completeness or usefulness of any information, apparatus, product or process disclosed, or represents that its use would not infringe privately owned rights.

TECHNICAL INFORMATION DIVISION
LAWRENCE BERKELEY LABORATORY
UNIVERSITY OF CALIFORNIA
BERKELEY, CALIFORNIA 94720