

Lawrence Berkeley National Laboratory

Recent Work

Title

ANGULAR DISTRIBUTION OF BREMSSTRAHLUNG RADIATION

Permalink

<https://escholarship.org/uc/item/7xd4z74r>

Author

Rosengren, Jack W.

Publication Date

1952-11-03

UNIVERSITY OF CALIFORNIA - BERKELEY

TWO-WEEK LOAN COPY

*This is a Library Circulating Copy
which may be borrowed for two weeks.
For a personal retention copy, call
Tech. Info. Division, Ext. 5545*

RADIATION LABORATORY

DISCLAIMER

This document was prepared as an account of work sponsored by the United States Government. While this document is believed to contain correct information, neither the United States Government nor any agency thereof, nor the Regents of the University of California, nor any of their employees, makes any warranty, express or implied, or assumes any legal responsibility for the accuracy, completeness, or usefulness of any information, apparatus, product, or process disclosed, or represents that its use would not infringe privately owned rights. Reference herein to any specific commercial product, process, or service by its trade name, trademark, manufacturer, or otherwise, does not necessarily constitute or imply its endorsement, recommendation, or favoring by the United States Government or any agency thereof, or the Regents of the University of California. The views and opinions of authors expressed herein do not necessarily state or reflect those of the United States Government or any agency thereof or the Regents of the University of California.

UNIVERSITY OF CALIFORNIA

Radiation Laboratory

Contract No. W-7405-eng-48

ANGULAR DISTRIBUTION OF BREMSSTRAHLUNG RADIATION

Jack W. Rosengren

November 3, 1952

Berkeley, California

ANGULAR DISTRIBUTION OF BREMSSTRAHLUNG RADIATION

Jack W. Rosengren*

Radiation Laboratory, Department of Physics
University of California, Berkeley, California

November 3, 1952

ABSTRACT

A measurement has been made of the angular distribution of the 322 Mev bremsstrahlung radiation from the Berkeley synchrotron. The bremsstrahlung is produced by bombarding an internal 0.020 in. thick Pt target. The photons were detected by the beta-activity induced in small Cu discs by the $\text{Cu}^{63}(\gamma, n)\text{Cu}^{62}$ reaction. This reaction would be produced mainly by that part of the bremsstrahlung spectrum of energy near 17.5 Mev.

The angular spreading (of order of $6mc^2/E$) is observed to be much greater than the spread (of order mc^2/E) intrinsic in the bremsstrahlung production process. The theory of Schiff attributes this greater spread to the multiple Coulomb scattering of the electrons in the target before radiation. The observed angular distributions is compared with some theoretically predicted distributions and found to be considerably narrower. Its full width at half maximum is 9.2 ± 0.6 milliradians. This fact could indicate an over estimate of electron scattering at 322 Mev, but the narrower distribution is more likely attributable to the special conditions present in a synchrotron.

* Now at Department of Physics, M. I. T.

ANGULAR DISTRIBUTION OF BREMSSTRAHLUNG RADIATION

Jack W. Rosengren

Radiation Laboratory, Department of Physics
University of California, Berkeley, California

November 3, 1952

Introduction

In addition to the intrinsic interest that it offers, the angular distribution of the bremsstrahlung radiation from a synchrotron is of considerable practical concern. It enters into such matters as the selection of optimum collimation, the determination of the total output of the machine, and the calculation of the bremsstrahlung spectrum passing through a collimator. The angular spread (full width at half maximum in radians) intrinsic in the bremsstrahlung radiation process is of the order of mc^2/E where E is the total electron energy and mc^2 is the rest energy. The radiation from thick targets such as those in synchrotrons has, however, a considerably broader angular distribution, the full angle at half maximum being of the order $6mc^2/E$ for the 322 Mev Berkeley synchrotron. This increased spread is believed to be caused chiefly by the multiple scattering of the electrons in the target before radiation.

Schiff¹ has given a theory for the angular distribution of thick target bremsstrahlung based on the multiple scattering of the electrons in the target. Lanzl and Hanson², in an attempt to fit their own experimental data, have calculated somewhat narrower distributions than Schiff's using a different evaluation of the electron scattering.

The angular distribution of bremsstrahlung has been measured by various experimenters at lower energies. In the cases where a specialized target (often a wire) is used, there can be no direct comparison with theory. Koch and Carter³, using a uniformly thick 0.005 inch Pt target at 19.6 Mev, found an angular distribution which within statistics agreed with Schiff's function. The distributions measured by Lanzl and Hanson² using various targets at 16.9 Mev are narrower than those predicted by Schiff but are in good agreement with their own calculations. Baldwin et al.⁴ have studied the angular distributions produced by 70 Mev electrons in synchrotron targets

of various thicknesses and Z, finding excellent agreement with Schiff's theory for low Z but narrower distributions for high Z.

The following is a report of a study made of the angular distribution of the bremsstrahlung from the 322 Mev Berkeley synchrotron.

Experimental Conditions and Procedure

Arrangement The angular distribution of the bremsstrahlung from the Berkeley synchrotron was measured under the following conditions. The so-called short beam was used, in which case the rf accelerating voltage is turned off sharply at peak field. (For the "long beam" the envelope of the rf voltage is more gradually brought to zero, producing a beam spread out much more in time.) Loss of energy by radiation causes the electron orbit to collapse, electrons striking the Pt target on the inner wall over a period of about 20 μ sec. The electron energy upon reaching the target has been estimated by Powell et al.⁵ to be 322 ± 6 Mev. During the collapse of the short beam, it is estimated that the radius of the electron orbit is reduced 3.0×10^{-4} cm per turn.

The target employed was the 0.020 inch thick Pt target that was in use in the Berkeley synchrotron during the period 1948-1951 and is the same thickness as the one now in the machine. The target was in the shape of a uniformly thick flag about 5/16 in. x 1 in. x 0.020 in. Its thickness represented 1.15 gm/cm^2 or about 0.18 radiation lengths.

Detectors The bremsstrahlung was detected by the activity produced in small, 0.035 in. thick Cu discs of 1/8 inch diameter by the $\text{Cu}^{63}(\gamma, n)\text{Cu}^{62}$ reaction. The excitation curve for this (γ, n) reaction has been extensively investigated^{6, 7}. The curve has a resonance shape with a peak at 17.5 Mev and a full-width at half-maximum of about 5.5 Mev; therefore, the photons detected in this experiment were of energy near 17.5 Mev. To maintain the detector discs in accurately determined positions during bombardment they were mounted on an Al frame in 1/8 in. diameter depressions spaced 0.15 inch apart as shown in Fig. 1. Actually, to obtain more activity, two discs, one behind the other were mounted at each point.

Since Fig. 1 is not drawn perfectly to scale it might appear that the Pb wall (usually used to collimate the beam) that is shown could produce some interference with the beam. Actually the aperture through which the beam passed subtended an angle of 62 milliradians, which is outside

the angular range in which measurements were made. Effects due to scattering at the edges of the aperture would be negligible.

Procedure The mount was centered in the bremsstrahlung beam using the relative activities induced in the Cu discs at the four positions immediately adjacent to the center. The usual method of aligning the apparatus using a transit was not sufficiently accurate. In fact, when by means of photographic film the mount had been accurately centered in the beam passing through a 1/8 inch collimator, it was found to be about 6×10^{-4} radians (about 12 percent of the half angle of the cone at half intensity) from the position of maximum intensity. Actually for no run was the mount perfectly centered in the beam, but the position of the center could easily be determined from the data.

The procedure was to expose two to four detectors at a time, a detector at center serving as a monitor for each exposure. After a 15 to 20 minute bombardment the activities of the various discs were counted simultaneously for 15 minutes, using Victoreen mica-end-window Geiger tubes. Under these conditions only the 10 min. half-life Cu^{62} beta-activity was observed. The counting efficiencies of the different Geiger counters were normalized and continually checked using two uranium β -standards. The efficiencies were observed to remain constant and differed among the tubes by less than 6 percent.

Over a period of three months three separate measurements of the distribution were made. The distances from detector mount to the synchrotron target in the three cases were 81 inches, 165 inches and 184 inches. In the first measurement, data was taken along two perpendicular diameters through the center of the radiation pattern. In the other two cases, except for data taken just around the center to fix that point, measurements were made only along the horizontal radius in the direction AB shown in Fig. 1.

Results The results of the three series of measurements are shown in Fig. 2.

The directions labeled in Fig. 2 are perhaps confusing. The direction denoted "left" refers to the horizontal direction labeled AB in the plan diagram of Fig. 1. For the electrons striking the 0.020 in. Pt target this is the direction towards the closer target edge. The angles subtended by the diameters of the detector discs are indicated in the legend and were 1.85, 0.91 and 0.92 milliradians for series 1, 2, and 3, respectively. The uncertainties shown are standard deviations based on counting statistics only.

Also shown in Fig. 2 are calculated angular distributions of bresmstrahlung produced in a 0.020 inch thick Pt target by 322 Mev electrons based on functions given by Schiff (curve A) and by Lanzl and Hanson (curve B). The theoretical basis of these two functions and an explanation of their disagreement is given in the next section. In the last section a discussion is given of the disagreement between the experimental and theoretical distributions.

Theory of the Angular Distribution of Bremsstrahlung Radiation

Intrinsic Spread (Thin Target Distributions) Sommerfeld⁸ and Schiff⁹ have derived expressions for the intrinsic spread of the bresmstrahlung radiation, which should be applicable to very thin targets. These expressions are obtained by integrating the Bethe-Heitler differential bresmstrahlung cross section over the angles of the scattered electron.* Sommerfeld's derivation does not include screening of the nuclei by their electron clouds, whereas the following expression obtained by Schiff takes screening into account:

$$\sigma(k, x) dkdx = 4\alpha Z^2 r_0^2 \frac{dk}{k} x dx F(x, k, E_0) \tag{1}$$

where $F(x, k, E_0)$ is the angular distribution function

$$F(x, k, E_0) = \frac{16x^2 E}{(x^2 + 1)^4 E_0} - \frac{(E_0 + E)^2}{(x^2 + 1)^2 E_0^2} + \left[\frac{E_0^2 + E^2}{(x^2 + 1)^2 E_0^2} - \frac{4x^2 E}{(x^2 + 1)^4 E_0} \right] \ln M(x, k) \tag{2}$$

$$\frac{1}{M(x, k)} = \left(\frac{mc^2 k}{2E_0 E} \right)^2 + \left(\frac{Z^{1/3}}{C(x^2 + 1)} \right)^2$$

where

$\alpha = 1/137 =$ fine structure constant

$E_0 =$ incident electron energy

$E =$ scattered electron energy

$k = E_0 - E =$ radiated photon energy

* These results when in turn integrated over the photon angles give the Bethe-Heitler bresmstrahlung spectrum.

- $x = E_0 \theta / mc^2$, the reduced angle
- θ = angle between incident electron and photon
- $r_0 = e^2 / mc^2$ = classical electron radius
- $C = 183 / \sqrt{\mathcal{E}} = 111$
- \mathcal{E} = base of natural logarithms

This becomes the same as Sommerfeld's result when in $M(x, k)$ Z is set to equal zero (no screening). Complete screening holds when $\left(\frac{Z^{1/3}}{C(x^2 + 1)}\right)^2 \gg \left(\frac{mc^2 k}{2E E_0}\right)^2$ i. e., k/E_0 small.

The shape of the angular distribution is given by the function $F(x, k, E_0)$, which is proportional to the photon intensity per unit solid angle. For complete screening it is seen to depend on k and E_0 as a function of k/E_0 only. Actually the shape, plotted in terms of the reduced angle $x = E_0 \theta / mc^2$ is not strongly dependent on k and E_0 . As a consequence the radiation spectrum is roughly independent of angle, although low energy quanta are slightly more peaked toward $\theta = 0$.

Thick Target Distributions The angular distribution of bremsstrahlung from thick targets was first treated by Schiff¹ with the following considerations: For small angles the William's multiple scattering theory¹⁰ predicts the following angular distribution of electrons as a function of depth, t , into a target (normalized so that the integral over all angles is unity):

$$P(\theta, t) = \frac{1}{2\pi\beta t} \exp(-\theta^2 / 2\beta t) \tag{3}$$

- where
- $\beta = \left(\frac{9.2Ze^2}{E}\right)^2 N$
- N = number of atoms per unit volume
- E_0 = electron energy

This assumes that the attenuation is negligible. Since radiation is equally probable at all depths t the effective angular distribution of the radiating electrons is the integral of Eq. (3) over the total target thickness x .

$$P(\theta) = \frac{1}{2\pi\beta} \left[-Ei(-\theta^2 / 2\beta x) \right] \tag{4}$$

where Ei is the exponential integral function given by

$$-Ei(-y) = \int_y^\infty \frac{e^{-z}}{z} dz, \quad y > 0$$

and is tabulated in Jahnke and Emde¹¹.

Since the intrinsic radiation spread is narrow, compared with the spread of the electrons, the photons will be radiated essentially in the direction of the electron's line of motion and $P(\theta)$ will also be the angular distribution of the radiation. This is not true at angles of the order mc^2/E about $\theta = 0$ since at these angles the intrinsic radiation spread becomes important in determining the distribution. (It might be noted that $P(\theta)$ given in Eq. (4) diverges at $\theta = 0$). For small angles Schiff, by numerical calculations, folded together $P(\theta)$ and an expression for the intrinsic spread which was approximately the same as that of Eq. (2). He obtained finally for the intensity of radiation at angle θ , relative to that at $\theta = 0$

$$I(\theta) = \frac{-Ei(-\theta^2/2\beta x)}{\ln \frac{2\beta x E_0^2}{m^2 c^4} - 0.5772} \quad (5)$$

$I(\theta)$ as given in Eq. (5) does not contain any dependence on k , the photon energy and represents an average over all values of k/E_0 ; however, as mentioned above, the radiation spectrum is roughly independent of angle. $I(\theta)$ evaluated for 322 Mev electrons incident on a 0.020 inch Pt target is plotted as curve A in Fig. 2.

The curve B plotted in Fig. 2 is based on a function given by Lanzl and Hanson.² Essentially the following derivation of their expression for the thick target bremsstrahlung angular distribution has been given by Lawson¹² and by Lanzl and Hanson.²

The function $F(\theta, k, E_0)$ eq. (2), for the intrinsic spread of the radiation may for small angles very accurately be approximated by the sum of two gaussians.

$$F(\theta, k, E_0) \approx a_1 \exp \left[-\left(\frac{E_0 \theta}{mc^2 \theta_1} \right)^2 \right] + a_2 \exp \left[-\left(\frac{E_0 \theta}{mc^2 \theta_2} \right)^2 \right] \quad (6)$$

The constants a_1 , a_2 , θ_1 , and θ_2 actually are slightly dependent on k , E_0 and Z .

The electron multiple scattering distribution at depth t (normalized such that the integral over all angles is unity) may, for the small angles that concern us, be expressed as a gaussian function.

$$P(\theta, E, t) \approx \frac{E_0^2}{\pi b t} \exp \left(-E_0^2 \theta^2 / b t \right) \quad (7)$$

When $F(\theta, k, E_0)$ and $P(\theta, E, t)$ are folded* together, we obtain the contribution to the angular distribution from radiation at target depth t .

$$I(\theta, k, E_0, t) = \frac{a_1 m^2 c^4 \theta_1^2}{m^2 c^4 \theta_1^2 + bt} \exp \left[-E_0^2 \theta^2 / (bt + m^2 c^4 \theta_1^2) \right] \quad (8)$$

$$+ \frac{a_2 m^2 c^4 \theta_2^2}{m^2 c^4 \theta_2^2 + bt} \exp \left[-E_0^2 \theta^2 / (bt + m^2 c^4 \theta_2^2) \right]$$

Integrating over the total target thickness T we obtain the net radiation pattern, normalized to unity at $\theta = 0$.**

$$I(\theta, k, E_0) = \frac{a_1 \theta_1^2 \left[-\text{Ei} \left(\frac{-E_0^2 \theta^2}{bT + m^2 c^4 \theta_1^2} \right) + \text{Ei} \left(\frac{-E_0^2 \theta^2}{m^2 c^4 \theta_1^2} \right) \right] + a_2 \theta_2^2 \left[-\text{Ei} \left(\frac{-E_0^2 \theta^2}{bT + m^2 c^4 \theta_2^2} \right) + \text{Ei} \left(\frac{-E_0^2 \theta^2}{m^2 c^4 \theta_2^2} \right) \right]}{a_1 \theta_1^2 \ln \left[1 + bT / m^2 c^4 \theta_1^2 \right] + a_2 \theta_2^2 \ln \left[1 + bT / m^2 c^4 \theta_2^2 \right]} \quad (9)$$

The value one obtains for the constant b in the gaussian approximation of the electron scattering distribution differs among the various multiple scattering theories. The theory of Moliere¹³ which predicts somewhat narrower spreads than do the theories of Williams¹⁰ and others, especially for large Z , appears to give the best fit to experiment¹⁴. Moliere's theory gives a very involved expression for $P(\theta, E, t)$; however, for any specific case a value of b can be obtained graphically which makes (7) a very good approximation.

Eq. 9 is plotted as curve B in Fig. 2. To evaluate this expression for the case of an incident electron energy, E_0 , of 322 Mev and a photon energy, k , of 17.5 Mev the values of the constants a_1 , a_2 , θ_1 , and θ_2 , were determined by a graphical fit of the intrinsic spread $F(x, k, E_0)$, Eq. (2), to be an $a_1 = 0.73$,

* The convolution of two two-dimensional gaussian functions (written $\exp [-\theta^2 / 2\theta_1^2]$) $\exp [-\theta^2 / 2\theta_2^2]$ is $\frac{2\pi\theta_1^2\theta_2^2}{\theta_1^2 + \theta_2^2} \exp [-\theta^2 / 2(\theta_1^2 + \theta_2^2)]$ when θ_1 and θ_2 are small.

** At $\theta = 0$ Eq. (9) is indeterminate and the asymptotic relation $-\text{Ei}(-y_1) + \text{Ei}(-y_2) \approx \ln (y_2 / y_1)$ must be used.

$a_2 = 0.27$, $\theta_1^2 = 0.340$ radian², and $\theta_2^2 = 2.37$ radian². The value of bT appropriate to the 0.020 inch Pt target was determined from Moliere's theory¹³ to be $244 \text{ m}^2 \text{ C}^4$ radian². These values give the curve B shown in the figure.

The disagreement between curves A and B is attributable to two roughly equal effects: (1) Schiff's curve is based on William's scattering formula, whereas the expression of Lanzl and Hanson was evaluated in terms of Moliere's theory which gives a narrower scattering distribution. (2) Schiff's expression represents an average over all value of k/E_0 . For the very small value of k/E_0 that we are considering here ($17.5 \text{ Mev}/322 \text{ Mev} = 0.054$) the distribution will be narrower than average. When these two effects are taken into account curve A is in agreement with curve B, which should be the true distribution for the energies and target thickness considered.

Comparison of Experimental Results with Theory

The following features of the experimental data may be noted: There is no definite asymmetry within the angles of observation; one might expect the spread to be smaller in the direction of scattering out the target's edge. There seems to be somewhat of a disagreement among the three measurements. This inconsistency might be attributable to unknown differences in the operating conditions of the synchrotron, i. e., differences in the manner in which the electrons were striking the target. The measured distribution is narrower than the theoretical predicted radiation pattern; the measured pattern has a full width at half-maximum of 9.2 ± 0.6 milliradians.

If the theoretical prediction were actually invalid it would mean that even Moliere's recent theory of multiple scattering overestimates the scattering of high energy (300. Mev) electrons in high Z materials. Eq. (9) when evaluated with a 21 percent narrower scattering distribution would agree quite well with the experimental points in Fig. 2.

A number of reasons may be listed as to why, in general, it is difficult to compare the angular distribution of bremsstrahlung from a betatron or synchrotron target with a theoretically predicted distribution.

- (1) The target may not be of uniform thickness. Actually the standard target in many machines is in the form of a wire.
- (2) Oscillations of the accelerated electrons cause them to strike the target at a variety of angles, tending to spread out the radiation distribution.

(3) The electrons because of the small pitch of their spiral path into the target strike close to the outer edge of the target. In the subsequent scattering of the electrons inside the target, the ones scattered to larger radii may be scattered out of the target through its edge. This should lead to an asymmetry in the angular distribution of radiation.

(4) If the target is not perfectly normal to the entering beam or if the target edge is not perfectly smooth and square (to within distances of the order of the pitch of the spiral electron path, 3×10^{-4} cm) the beam could nick the edge of the target without passing through the full target thickness. This condition would also lead to an asymmetry in the angular distribution of the bremsstrahlung.

(5) With thin targets multiple traversals of the electrons through the target will influence the resulting bremsstrahlung.

(6) Electrons deflected by the target through scattering or ionization loss will strike the walls of the donut accelerating chamber or elsewhere, producing radiation from secondary sources.

Of these possible objections, only (2), (3) and (4) seem to apply to this measurement, limited to the component of the bremsstrahlung around 17.5 Mev at small angles. The effect of the oscillations of the electrons would be to broaden the angular distribution; hence, it cannot account for too narrow a distribution. The most reasonable explanation of the disagreement between the theoretical and observed distributions is that the electron beam was not passing through the full target thickness. A reasonable fit, Curve C in Fig. 2, is obtained by evaluating the theoretical expression, Eq. (9), using an effective target thickness of 0.0115 inches rather than the nominal thickness of 0.020 inch.

The asymmetry which might be expected under the circumstances mentioned in (3) and (4) is not apparent in the experimental data, but probably should only be expected at larger angles.

The conclusion would seem to be that unless special precautions are taken the effective thickness of a synchrotron target can be considerably less than its nominal thickness. A knowledge of the effective target thickness is important in that the bremsstrahlung spectrum will be dependent on this effective value. For theoretical calculation of this spectrum a value of the effective thickness of the target in any individual machine can be obtained from a measurement similar to the one described here.

ACKNOWLEDGEMENTS

The author acknowledges with pleasure the encouragement and advice given by Professor A. C. Helmholz. Grateful appreciation is given Mr. George McFarland and the entire synchrotron crew for their cooperation in use of the machine.

REFERENCES

1. L. I. Schiff, Phys. Rev. 70, 87 (1946)
2. L. H. Lanzl and A. O. Hanson, Phys. Rev. 83, 959 (1951)
3. H. W. Koch and R. E. Carter, Phys. Rev. 77, 165 (1950)
4. G. C. Baldwin, F. I. Boley, and H. C. Pollack, Phys. Rev. 79, 210 (1950)
5. W. M. Powell, W. Hartsough, and M. Hill, Phys. Rev. 81, 213 (1951)
6. B. C. Diven and G. M. Almy, Phys. Rev. 80, 407 (1950)
7. H. E. Johns, L. Katz, R. A. Douglas, R. N. H. Haslam, Phys. Rev. 80, 1062 (1950)
8. A. Sommerfeld, Wellenmechanik (Ungar, New York), p. 551
9. L. I. Schiff, Phys. Rev. 83, 252 (1951)
10. E. J. Williams, Phys. Rev. 58, 292 (1940)
11. E. Jahnke and F. Emde, Tables of Functions, New York, Dover Publications 1943, p. 6
12. J. D. Lawson, Proc. Phys. Soc. A63, 653 (1950)
13. G. Moliere, Z. Naturforsch, 3a, 78 (1948)
14. A. O. Hanson, L. H. Lanzl, E. M. Lyman, and M. B. Scott, Phys. Rev. 84, 634 (1951)

FIGURE CAPTIONS

1. Experimental arrangement for measurement of the angular distribution of bremsstrahlung radiation.
2. Angular distribution of 17.5 Mev photons in the 322 Mev bremsstrahlung beam of the Berkeley Synchrotron.

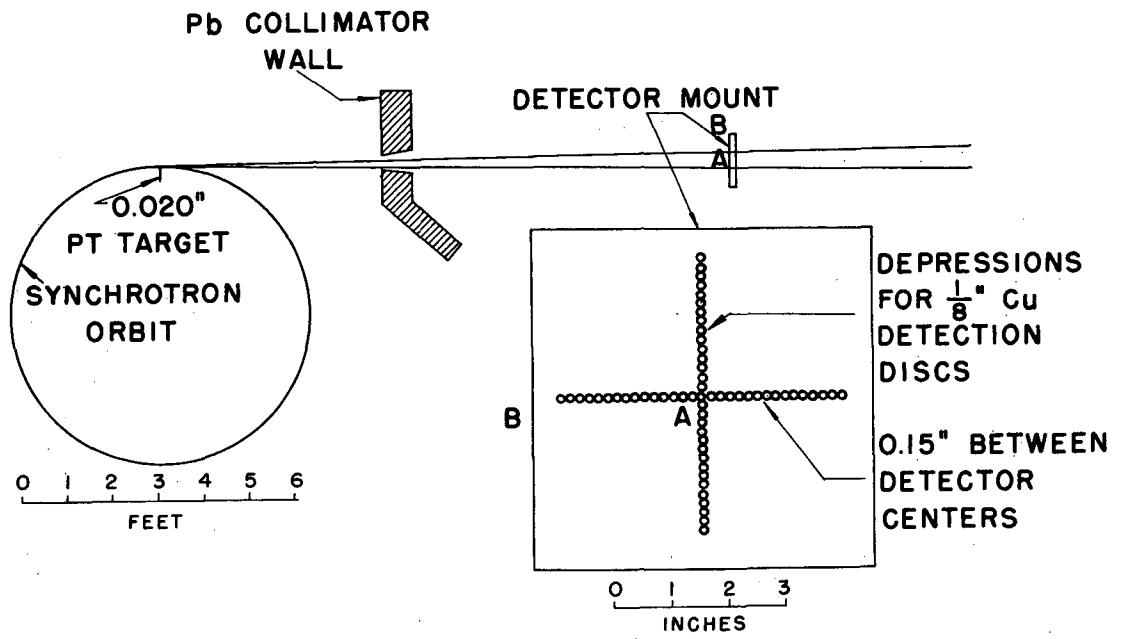

MU3996

Fig. 1

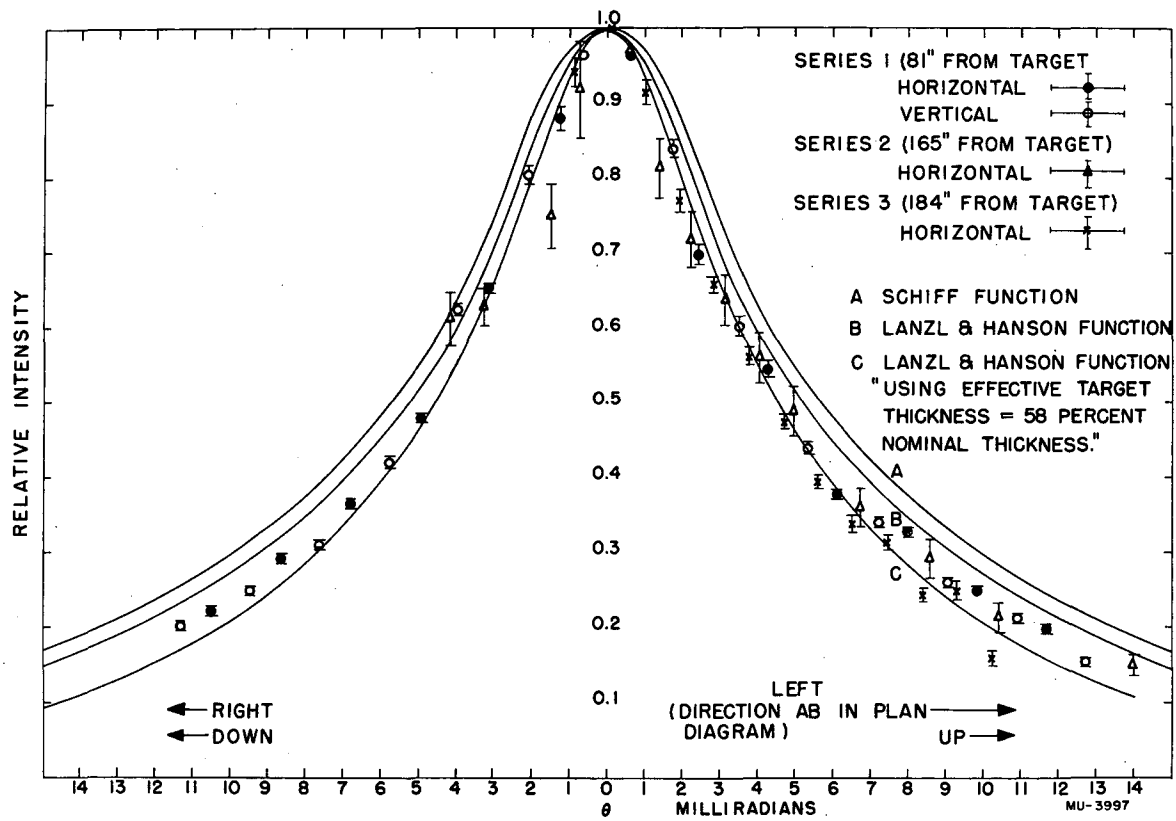

Fig. 2