

UC San Diego

SIO Reference

Title

Scour and Burial of Bottom Mines: a Primer for Fleet Use

Permalink

<https://escholarship.org/uc/item/7vz9j289>

Authors

Inman, Douglas L.
Jenkins, Scott A.

Publication Date

2002-09-01

SCOUR AND BURIAL OF
BOTTOM MINES

A PRIMER FOR FLEET USE

Douglas L. Inman and Scott A. Jenkins

Integrative Oceanography Division
Scripps Institution of Oceanography
University of California, San Diego
La Jolla, CA 92093-0209

September 2002

SIO Reference Series No. 02-8

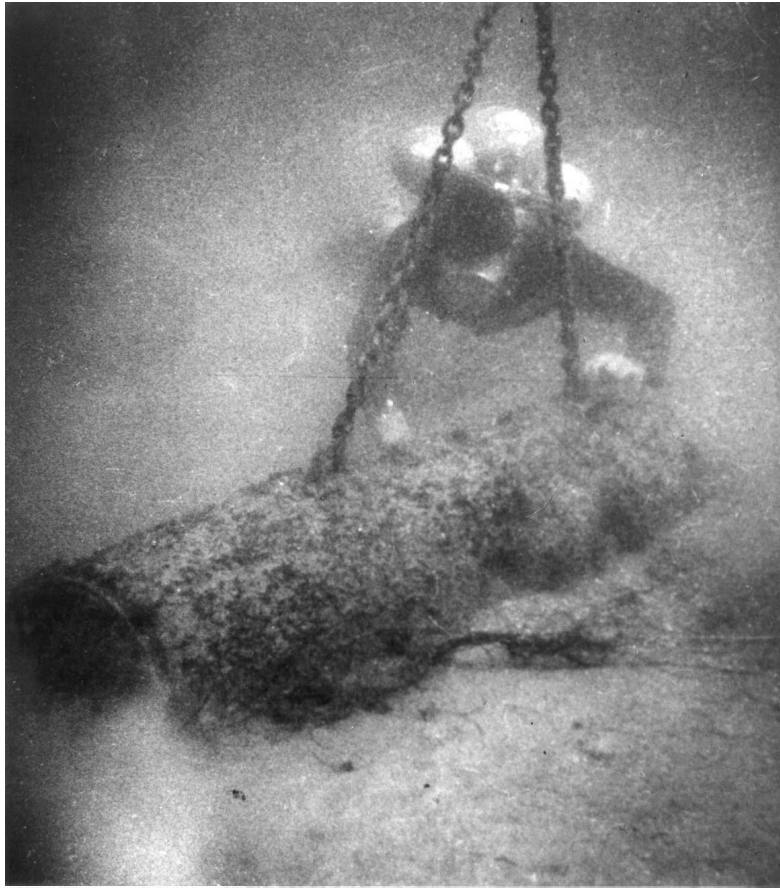

diver over partially buried mine.

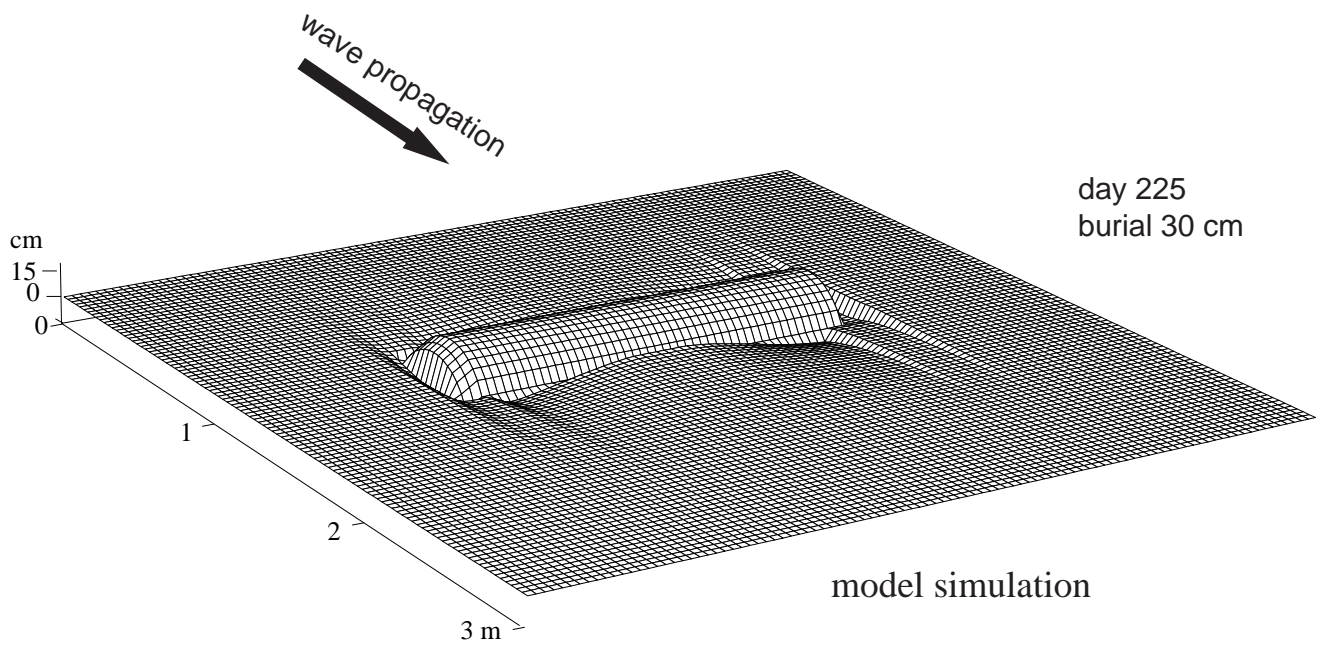

SCOUR AND BURIAL OF BOTTOM MINES

A PRIMER FOR FLEET USE

Douglas L. Inman and Scott A. Jenkins

Integrative Oceanography Division
Scripps Institution of Oceanography
University of California, San Diego
La Jolla, CA 92093-0209

September 2002

SIO Reference Series No. 02-8

Contents

PREFACE , vi

1. INTRODUCTION , 1-1

1.1 Types of Mine and Their Deployment , 1-3

1.2 Mine Size and Shape , 1-5

Table

Figures

2. REVIEW OF OBSERVATIONS ON MINE SCOUR, BURIAL, AND IMPACT , 2-1

A WAVE FORCING , 2-1

2.1 Scripps Studies of Mine Burial in the Early 1950s , 2-1

2.2 Naval Electronics Laboratory Studies of Mine Burial, 2-4

2.3 Studies of Mine Burial Near Sydney, Australia, 2-6

2.4 Naval Coastal Systems Center Studies , 2-6

B TIDAL/RIVER FORCING AND IMPACT BURIAL , 2-8

2.5 Narragansett Marine Laboratory Studies of Mine Impact and Burial , 2-8

2.6 Recent Studies of Impact Burial and Penetration , 2-10

Table

Figures

3. MECHANICS OF SCOUR AND BURIAL , 3-1

3.1 Scour Mechanics , 3-2

3.2 Other Scour Mechanisms , 3-5

3.3 Scour/Burial Mechanisms and Mine Migration , 3-6

Figures

Contents (continued)

4. PREDICTION OF MINE BURIAL: A MULTI-FACETED PROBLEM , 4-1

- 4.1 Expert Systems Modeling (ESM) , 4-2
- 4.2 Process Modeling of Mine Scour and Burial , 4-3
- 4.3 Mine Burial Predictions , 4-10
 - Some Rules of Thumb for Mine Burial , 4-10
 - Typical Rates of Mine Burial , 4-12

Tables

Figures

5. REFERENCES , 5-1

Internet Sites Relevant to Mine Burial , 5-11

APPENDIX A: Coastal Type, Littoral Cells, and Bottom Sediment , A-1

- .1 Collision coasts , A-3
- .2 Trailing-edge coasts , A-4
- .3 Marginal sea coasts , A-6
- .4 Arctic coasts , A-7
- .5 Coral reef coasts, A-10

Table

Figures

APPENDIX B: Glossary of Terms

PREFACE

This primer is for fleet use as a means of rapid access to information on scour, burial, and re-exposure of bottom mines placed in nearshore waters. The format is easily adapted to a computer slide show where sequential illustrations such as progressive mine scour and burial could be in animated form. The illustrations detail mechanisms and burial rates characteristic of coastal and sediment type. The primer also addresses the ranges of uncertainty in mine burial estimates by showing burial dependence on mine characteristics and environmental factors. By providing both burial rate estimates and the probable error of those estimates, this primer facilitates tactical use and planning, particularly in areas of denied access.

The emphasis here is on field experiments of the scour and burial of bottom mines in shallow and very shallow water (3 m - 61 m) and their comparison with simulations from computer models. However, the complexity of mine warfare and mine use makes it necessary to briefly discuss categories of mines, their basic components, and their means of delivery and planting. The reader is advised to consult the references for detailed information on these related topics. We understand that other studies of bottom mine burial have been made. Here, we report on those studies that have been declassified and made available to us.

Acknowledgments

The primer was prepared for Surface Mine Countermeasure Units and the Very Shallow Water Detachment, NAVSEA PMS-490, with funding provided by the Office of Naval Research, Code 322-MG, Marine Geosciences, Mine Burial Prediction Program. Bob Olds of the Marine Mammal Systems Branch, Code D352, SPAWAR, San Diego, CA provided information on mine detection and neutralization methods. MNCS John A. Nahra of the Mobile Mine Assembly Unit One, Seal Beach, CA, provided drawings and physical specifications of U. S. and foreign mines. David Schneider of the Naval Oceanographic Office, Code N221 provided access to the Mine Warfare Pilots through the Security Director, Robert King, University of California, San Diego. Lisa Tubridy, Naval Coastal Systems Station (NCSS), Code R-24, Panama City, FL, with assistance from Nicole Bishop, NCSS Code A-83, provided specifications for rare and unusual mines and access to archival documents. Patricia Masters, SIO Coastal Morphology Group and Lisa Tubridy, made written comments on drafts of the primer.

1. INTRODUCTION

Mines are easily deployed weapons that were first developed in 1776 and have been used extensively during the American Civil War and in the 20th Century for denying area access and as surprise deterrents in neutral waters. Originally mines were crude devices, such as a keg of gun powder, and usually depended upon contact for detonation. However during recent decades, “smart” mines have been developed that respond selectively to mass proximity, acoustic and magnetic fields, and to discrete parts of the spectrum of these fields. Mines are becoming smaller with modern explosives technology, and in the future micro mines are likely to be deployed.

Mines are the hardest to find and most difficult to neutralize of all conventional weapons. The ability to detect and neutralize bottom mines is critically dependent on the scour pattern around the mine and on the degree of mine burial. Understanding of the causative mechanisms in scour pattern and burial become the essential elements in modeling and predicting mine performance and detectability. This aspect of mine warfare has been a neglected field of research and development until the Gulf War when a MANTA bottom mine disabled the Aegis class cruiser U. S. S. PRINCETON and an Iraqi LUGM-145 moored mine damaged the light aircraft carrier U. S. S. TRIPOLI. Even the crudest mines are dangerous to modern warships. The U. S. S. SAMUEL B. ROBERTS was damaged by a World War I vintage mine while patrolling the northern Persian Gulf during the Iran-Iraq conflict in 1988.

The devastating effect of mines on ships and personnel and their low cost and ease of deployment has made them a major threat to maritime operations and amphibious warfare. As mines have become smarter, mine countermeasures have become more complex and sophisticated. Modern navies employ an array of different mine warfare countermeasures. The United States uses or has under development a total of 61 different systems (Morison, 1995). These systems include command and control, tracking, sonar detection and mine classification, various mine sweeping procedures, magnetic detection and degaussing, remote operating vehicles (ROV), and marine mammals. Recent emphasis has focused on autonomous systems including uninhabited underwater vehicles (UUV) and autonomous underwater vehicles (AUV). UUVs are the military equivalent of ROVs and are usually guided from a parent ship through a cable, while AUVs have

no attached cables and are programmed for specific tasks. In spite of this vast array of countermeasures, there is no detection system for buried mines other than the porpoises deployed by Marine Mammal System (MMS MARK 7). In an analysis of United States countermeasures, Brown (1991) concludes that the U. S. Navy's ability to conduct mine countermeasures for amphibious operations is poor.

In terms of intended emplacement, there are three basic categories of sea mine: *bottom*, *moored*, and *drifting* (Donohue, 1998; MOMAG, 2000). Bottom mines are large negative buoyancy ordnance resting on the seafloor. Moored mines are buoyant ordnance tethered to a bottom anchor by a cable. Drifting mines float freely on or near the surface of the water. Some bottom mines may be laid in deeper water, and once activated by the target, become target-seeking (homing) propelled mines. Drifting mines are outlawed by the Hague Convention of 1907 (Levie, 1992) and are no longer used by the U. S. Navy, but are deployed by some rogue nations. Also, moored mines can break away from their tether and become drifting mines. Our concern here is with bottom mines (Frontispiece).

We suggest the following axiom for mine countermeasures:

Bottom mines in shallow water are mobile, and move around on hard bottoms. With sufficient sediment thickness, mines scour and bury. Once buried, mines can re-expose.

This primer describes the processes and time scales for scour and burial of bottom mines and similar negative buoyancy devices such as mine neutralization packages and other ordnance (UXO) that have been deployed or lost in nearshore waters and remain on the seafloor. There are two basic types of mine-bottom interactions: *impact burial* associated with the momentum of the object as it impacts the bottom, and *subsequent scour, burial, and re-exposure* associated with the action of waves and currents over the object as it rests on the bottom (Figure 1-1). Impact burial is important over fluid mud bottoms of sufficient thickness to completely cover the mine. Subsequent scour, burial, and re-exposure are important in all localities where the bottom material is gravel, sand, or silty sand or where a portion of the mine protrudes from a mud bottom.

1.1 Types of Mine and Their Deployment

Mines may be used in offensive and defensive roles. As offensive weapons they may be planted in enemy waterways, harbors, entrance channels, and anchorages as deterrents to military and commercial shipping. As defensive weapons, mines and mine fields may be laid in the peripheral areas surrounding friendly harbors, channels, anchorages, and possible amphibious assault beaches. In World War II, the B-29 mine laying missions of the U. S. 21st Bomber Command represented only 5.7% of their total effort in Japanese waters. Yet the Japanese estimate that this 5.7% was as effective as the other 94.3% of the effort (Patterson, 1970). Mines have exacted heavy tolls in ships and men in all wars of the 20th century. As a consequence, the threat of mine laying causes a disproportionate response; the threat becomes as important a deterrent as the mine's presence (Donohue, 1998; MOMAG, 2000).

Mines may be delivered by aircraft, mine layers, submarines, fishing and other surface craft, broadcast by hand, and launched by truck from the beach. Mine delivery by aircraft is most versatile, permitting large numbers of mines to be rapidly placed over large areas and in places such as rivers, lakes, and harbors not usually accessible to submarine or surface craft. Where stealth is required, submarines are used, while mine laying surface craft are usually employed for planting mine fields in friendly waters. Parachutes and fins may be attached to mines dropped from aircraft, and specially configured shapes are used for mines launched from the torpedo tubes of submarines (MOMAG, 2000). In contrast to these conventional procedures, third world countries and terrorist groups are often more direct in their delivery methods. They may not trouble themselves to remove a mine from its packing crate before deployment. They set the arming (firing) device while the mine is in its case and roll mine and crate overboard from small surface vessels such as fishing boats that arouse little attention from possible observers.

Bottom mines are usually planted in water depths less than about 200 m. At present, the U. S. Navy and NATO forces use the following terminology for depth zone:

- Surf: High tide to 3 m depth.
- Very Shallow Water (VSW): 3 m to 12 m.
- Shallow Water (SW): 12 m to 61 m.

There are five essential components to a typical bottom mine: *explosive loaded case* (case with *warhead*), *arming device*, *target detecting device* (TDD), *battery*, and *explosive train*. In addition, mines to be delivered by aircraft usually have *flight gear* which may include *fins* and/or a *tail section*. The fins are used to stabilize the mine during free fall, and the tail section may deploy a parachute to retard the fall velocity of the mine. As an example, the U. S. bottom mine QUICKSTRIKE (Mine MK62), consists of general purpose Bomb MK82 with three possible tail fins and tail sections. The bomb contains the explosive loaded case with arming device, TDD, battery and explosive train (MOMAG, 2000). This type that converts bombs into mines began with the U. S. Destructor series developed during the Vietnam War, and has dramatically increased the number of easily stockpiled mines (Friedman, 1998).

The main explosive charge (warhead) is contained in the explosive loaded case which determines the mines shape and size and houses the other basic components. The arming (firing) device provides a mechanical interrupt in the explosive (firing) train, providing safety from explosion until the mine is in its operating environment. Some of the larger, modern mines have a window on the arming device that gives a visual indication of whether the mine is “safe” or “armed.” The QUICKSTRIKE mine is armed when the arming wire is pulled by release of the mine from the aircraft (MOMAG, 2000).

Originally the target detecting device (TDD) for most sea mines was a simple contact device, the horn, that activated a firing train when pressed, moved, or broken by contact with a target. Many mines now in use in the surf and VSW zones, such as the Russian MAS-22 and VS-RM-30, are *contact mines*. Later, *influence mines* were developed where the TDD was activated by an acoustic or magnetic signal emanating from a more distant target. Modern mines are becoming increasingly “smarter” as more innovative circuitry is built into their firing systems and TDDs. The TDD responds to various combinations of magnetic, acoustic, and pressure signals. Modern mines also employ non-metallic composite cases that make them more difficult to detect by acoustic and magnetic sensors (e.g., the Italian MANTA mine). In addition to these more modern devices, mines may be attached by cable to the beach or riverbank and detonated by an observer (Duncan, 1962). These *manual mines* were used by the Viet Cong in the Vietnam War, as were *drifting mines* and *limpet mines* attached to ship hulls by swimming sappers and detonated by a timing device (Fulton, 1973).

1.2 Mine Size and Shape

Mines come in all shapes and sizes according to their intended use and type of delivery (Table 1-1). Mines planted by aircraft are usually modified bombs and prolate spheroidal in shape; those laid by surface craft may be any shape but are commonly cylindrical; while those delivered by submarine are cylindrical like torpedoes. Special purpose mines like the Swedish ROCKAN are wedge shaped so that they can be launched from piers and “glide” under water to more distant parts of fiords (Figure 1-2d). Surf zone and very shallow water mines are often common land mines that have been broadcast delivered to and across the surf zone from vehicles on the beach. Morison (1995) describes 158 different mine types available for use in 19 countries. The largest number of mine types are part of the arsenals of Russia (53 types) and the United States (30 types).

It has been shown that the amount and rates of scour and burial of objects on the sea floor under the influence of waves and currents is a function of their size, weight, and shape (Inman and Jenkins, in press 2002a). Shape is an essential variable because scour is related to the intensity of the vortex system that forms around the object as the current flows past it. Thus streamlined bodies scour less rapidly than bluff (blunt) bodies. Once scour depressions develop around the mine, then mines bury incrementally by moving into the depressions formed by the scour process, either by rolling (round bottom mines) or sliding (flat bottom mines). Observations and modeling (Jenkins and Inman, 2002) show that mine shape can be usefully classified into four general categories: a) cylindrical, b) prolate spheroids (bomb shaped), c) truncated cones, and d) other shapes where (a) and (b) are round bottom and (c) and (d) are flat bottom mines (Figure 1-2). The latter shape category includes hemispheres, and wedge or box shapes like the ROCKAN and F-80 mines (Table 1-1).

Table 1-1. Dimensions and weights of bottom mines cited, listed by shape category (Figure 1-2).

Mine Name	Country	Weight, kg	Length, cm	Diameter, cm
a. Cylinder				
HM MARK 36 MDDS 1-3	USA	454, 517 w/flight gear	160, 192 w/flight gear	47
MARK 25	USA	885	211	57
MARK 39	USA	918	224	27
MARK 52				
MOD-0	USA	270	152	48
MOD-1	USA	513	160	48
MOD-2-3	USA	531-540	178	48
MARK 55	USA	961	228	59
MARK 56	USA	907	290	56
MARK-57	USA	934	308	53
MDM-2	Russia	1413	230	79
MDM-3	Russia	635	158	45
MDM-4	Russia	1420	279	65
MDM-5	Russia	1470	306	63
JAM-30 ^a	Germany	960	287	53
b. Prolate Spheroid (bomb shaped)				
DESTRUCTOR MARK 59	USA	400	224	60
DESTRUCTOR MARK 36	USA	226	154	27
QUICKSTRIKE MARK 65	USA	1086	325	
QUICKSTRIKE MARK 67	USA	754	409	48.5
SLLM MARK 67 ^b	USA	754	409	48.5
			Height, cm	Diameter, cm
c. Truncated Cone or Hemisphere				
MANTA ^c	Italy	220	47	98
MAS-22	Italy	22	46	38

Table 1-1. (Continued)

Mine Name	Shape	Country	Weight kg	Height cm	Width cm	Length cm
d. Other Shapes						
ROCKAN GMI-100	wedge	Sweden	190	38.5	80	102
SIGEEL 400	tapered cylinder w/4 legs	Iraq	535	98	85	85
LUGM-145	flat cylinder	Iraq	250	88	88 ^c	57
VS-RM-30	flat cylinder	Italy	30	15	44	44
F-80	box	Sweden	450	76	76	198
MIRAB	oblate hemisphere	Russia	29	37	50 ^c	50 ^c
PDM-2b	cylinder/box	Russia	105	51 ^d	51 ^d	91

a East German copy of Soviet MDM-1.

b submarine launched.

c MARK 75 in the U. S. inventory.

d diameter.

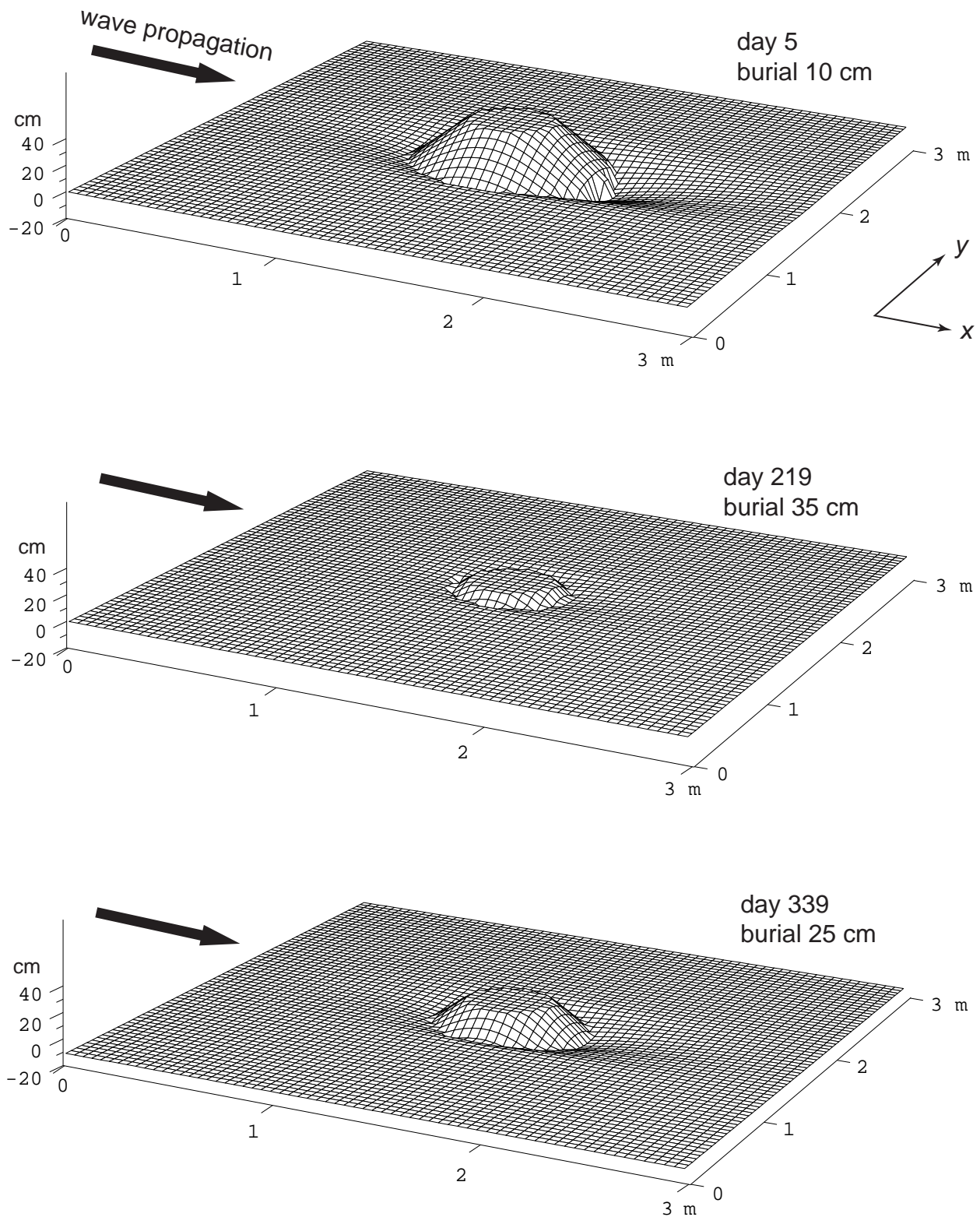
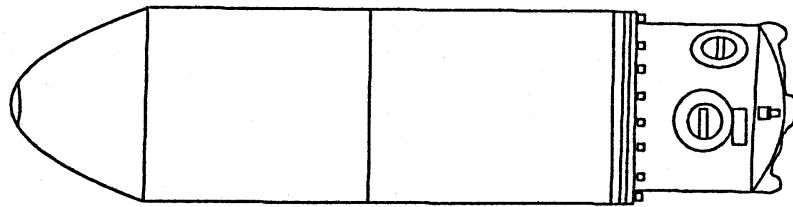
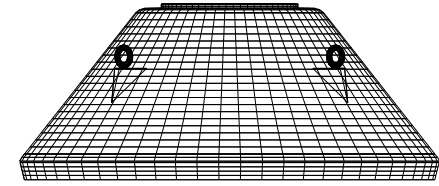

Figure 1-1. VORTEX Model simulation of nearfield scour / burial and re-exposure of a MANTA mine in water depth of 7 m subject to waves measured at Scripps Pier. [Excerpts from an animated sequence]



a. Cylinder
(Russian MDM-2)



c. Truncated Cone
(Italian MANTA)

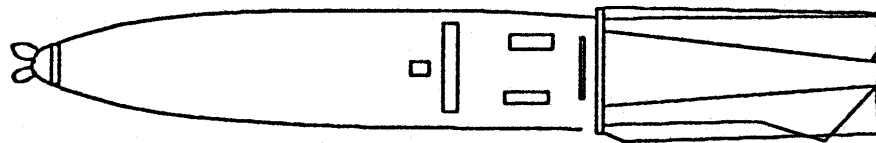

b. Prolate Spheroid With Fins
(US DESTROYER DST)

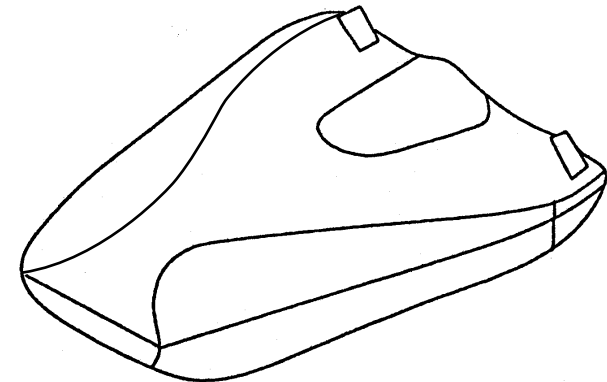

d. Wedge Shape
(Swedish ROCKAN)

Figure 1-2. General shape classes for bottom mines (not to scale). See Table 1-1 for mine dimensions.

2. REVIEW OF OBSERVATIONS ON MINE SCOUR, BURIAL, AND IMPACT

There have been relatively few detailed studies of the scour, burial and re-exposure of bottom mines. The observations that have been made show a distinct bimodal distribution with time. A number of studies were carried out in the 1950's following WW II; e.g., Scripps Institution of Oceanography (see Inman and Jenkins, 1996), Chesapeake Bay Institute (Burt et al., 1952), Naval Electronics Laboratory (Dill, 1958); and Narragansett Marine Laboratory (Donohue and Garrison, 1954; McMaster et al., 1955; Frazier and Miller, 1955). Few studies were conducted during the Cold War, but several studies were initiated following the Gulf War by Foxwell (1991), Mulhern (1993a, b; 1995), and Chu et al. (2002).

Observations show that burial is sensitive to the type of bottom sediment and the nature of the fluid forcing, and the size and shape of the object. Mines planted in areas of muddy sediments may sink upon impact and disappear into the mud. In contrast, mines planted in areas of sand, gravel, and rock undergo little burial upon impacting the bottom. This distinction has led to the two general categories of mine burial, *impact burial* and *subsequent burial*. Studies of mines placed on sandy bottoms show that subsequent burial occurs through a series of scour events followed by rolling or sliding of the mine into the scour depression. Since scour around objects is related to the shape and size of the object, classification of mines in terms of their size and shape was presented in the previous section (§1.2).

A WAVE FORCING

2.1 Scripps Studies of Mine Burial in the Early 1950s

During the early summer of 1952, an inert ground mine was placed off Scripps Institution of Oceanography (SIO) Pier in water depths of about 4 m by Bascom and Fry (1953). The bottom sediment at 4 m is a well sorted fine grained quartz sand with a median diameter that averages 200 μm with seasonal variations between 180 and 240 μm . The mine was a MARK 36, now known as HUNTING MINE (HM) MARK 36 and not to be confused with DESTRUCTOR "DST" MARK 36. HM MARK 36 is 1.6 m long, 47 cm in diameter, with a weight of 454 kg (1000 pound) in air (Figure 2-1). The mine was observed daily by divers who noted that it became buried in 3 to 5 days of summer wave action. It was unclear to what extent this was caused by scour or by seasonal changes in sand

level, but the rapid burial suggested scour. It was noted that wave action caused the mine to orient so that its long axis was always normal to the crest of the waves. On one occasion the mine orientation was rotated 60° in 3 days as the wave direction changed.

In May 1952, two HM MARK 36 mines were placed in depths of 9 m and 17 m on the shelf near the SIO pier by Mills and Jackson, SIO divers (see Inman and Jenkins, 1996). The bottom sediments were fine gray sand with median diameter of 140 μm (0.14 mm) at the 9 m depth and about 125 μm at 17 m depth. The mines were lowered from SIO's research vessel *Paolina T* on 8 May 1952. Bottom conditions and mine scour were monitored by divers supported by an amphibious DUKW (Figures 2-1). The deeper mine was observed to have a scour trough developed around it on the day of placement. Measurements two days later showed the scour around the mine to be 36 cm wide and 20 cm deep, associated with surface waves 1.2 m high and 6 second period. This was the last observation of this mine as subsequent efforts to locate it were unsuccessful.

Observations made 30 minutes after the HM MARK 36 was placed at the shallow depth (9 m) showed the mine to be buried in the sand bottom about one-third of its diameter with an actively scouring hole about 20 cm deep immediately surrounding the mine. By 11 days following deployment, the mine had buried so that only about one-quarter of its diameter was above the surrounding bottom. Observations at the mine site 27 days after deployment showed the mine to be completely buried with a covering of 15-18 cm of sand determined by probing. The scour rates for this mine are plotted in Figure 2-9.

In March 1953, two inert HM MARK 36 mines were placed on the sandy shelf off the Scripps Institution of Oceanography by lowering from the Shore Processes DUKW (Inman and Jenkins, 1996). The mines were placed at depths of 17 m and 23 m in the vicinity of stations previously selected for a controlled study of sand level changes using reference rods. The bottom sediment was fine gray sand with median diameters of about 110 μm at both sites. The procedure used arrays of 6 rods that protrude from the bottom sediment (Figure 2-2) and are periodically measured by divers (Inman and Rusnak, 1956). The mines were placed about 15 m from the array and an additional five reference rods placed 3 m on-offshore and alongshore from the mines. This procedure provided accurate data for the change in sand level at the site of the mines, and sand level was found to range over a three year period between ± 3 cm at 17 m depth and ± 2 cm at 23 m depth

(Figure 2-3). Thus mine burial at these depths (Figures 2-4, 5 and 6) was shown to be due to scour around the mine rather than seasonal changes in sand level.

The mines and reference-rod sites were intensively monitored for one year with occasional observations extending over a three year period. Both mines scoured and buried about two-thirds of their diameters during the high waves of the spring of 1953, but scour was only moderate during the lower summer waves compare (Figures 2-4, 5, 6, 7 and 8.) The onset of more intense wave action in mid-November 1953 resulted in active scour and complete burial of both mines by 28 December 1953, just over 9 months after placement. It is clear from the chronology of scour (Figures 2-9 and 10), that had the spring wave intensity continued, the mines would have buried within 2 months or less. Once buried and covered by a layer of sand 6-10 cm thick, the mines never reappeared. This is because the seasonal sand level changes at these depths (17 and 23 m) did not exceed about ± 3 cm during this period of observations (Figure 2-3).

The results of these studies of HM MARK 36 are summarized in Figures 2-9 and 10. Mine scour and burial increased with increasing wave intensity and with decreasing depth. The mine at 9 m depth on fine sand bottom scoured and buried within one month and did not reappear. The mines at 17 and 23 meter depths scoured and buried about three quarters of their depth during two spring months of 1953, remained partially exposed during the smaller waves of summer, then completely buried during the higher waves of winter. It is interesting to note that the scour depressions filled in with sand during periods of low waves (Figure 2-5 and 7), but rapidly scoured deep depressions with the onset of high waves (Figure 2-6). These deep depressions scavenge coarse material such as pebbles and sea shells that changes the acoustic signature of the mine site, while organic fouling may soften the signature of the mine itself (Figure 2-5 and 7). Other types of fouling such as clumps of surf grass and egg-case masses associated with spawning squid may completely cover and mask bottom mines optically and acoustically (Figure 2-11).

Diver observations and measurements of the distance of the mine from the adjacent reference rods show that these cylindrical mines move onshore and bury by rolling into their scour holes (Figure 2-10). Much later, measurements by Jenkins and Inman (2002) show that flat bottom mines such as the Italian MANTA

(Figure 1-2) moved into their scour holes by sliding, requiring the inclusion of a granular friction relation in modeling mine burial (refer to §4.1).

It was originally anticipated that this 1952-1954 study would lead to a published paper on scour around objects. However, although the Korean War (1950-52) was over, the national security concerns associated with the McCarthy era and Senate hearings (1953-54) still prevailed, and observations of mine scour were classified. As a result, this study was not published at that time. Fifty years later these observations are being used as ground truth for a computer model of scour, and the observations and predictive models have been published in the open literature (Inman and Jenkins, 1996; in press 2002a; Jenkins and Inman, 2002).

2.2 Naval Electronics Laboratory Studies of Mine Burial

Robert F. Dill, who participated as a Scripps graduate student and diver on the La Jolla field investigations, subsequently conducted an investigation on the shelf off Mission Beach while working at the Navy Electronics Laboratory, Point Loma. Some generalities from the La Jolla studies were included in Dill's (1958) classified report, which has now been declassified and is summarized below.

Observations of scour and burial were conducted by the Naval Electronics Laboratory (now SPAWAR), San Diego, California in 1955. These studies were carried out off Mission Beach, California, about 10 km south of the Scripps Institution of Oceanography. The study employed the cylindrical (47 cm diameter, 1.6 m long) HM MARK 36 mine in water depths of 9, 19 and 21 m, and a variety of smaller objects of different shape in depths of 4 and 9 m. The smaller objects included a hemisphere (60 cm diameter, 16 kg weight in air), a hemi-oblate spheroid (60 cm diameter, 16 kg weight), and cylinders (30 cm diameter, 60 cm length, with weights of 17 and 45 kg). The beach and near-surf bottom sediment to 4 m depth is fine gray quartz sand with median diameter of about 150 μm . Offshore in depths of 19 m the bottom sediment is very fine gray sand about 90 μm in median diameter. At the 21 m depth the bottom sediment was much coarser, consisting of well sorted brown medium size sand with a median diameter of 310 μm . The three-fold difference in sand size at these similar depths provided a comparison of burial rates in different size bottom sediment.

The study showed that the burial behavior of the HM MARK 36 mines at 9 m and 19 m depths was quite similar to that described off Scripps at similar depths

(§2.1). At 9 m depth, the HM MARK 36 mine buried about one-half of its diameter in 3 to 8 days during the spring of 1955, buried to about two-thirds its diameter during smaller summer waves, and was about 90% buried by fall, 7 months later. At 19 m depth in very fine sand, the mine burial rate was much slower but had buried about one-half its diameter after 7 months, including small summer waves. In contrast, at 21 m depth in medium size sand and under the same wave conditions, as the two mine positions were about 100 m apart, the mine had buried only about one-third of its diameter.

Under wave action, behavior and burial characteristics were quite different between the hemisphere and the hemi-oblate spheroid (compare Figure 2-12 and 13). In appearance, the latter is like a streamlined hemisphere with less height and rounded edges. The hemisphere was reasonably stable in tilt when placed flat-side down in water depth of 9 m. Scour depressions began developing as soon as the object was placed on the bottom, and within 24 hours the hemisphere resided in a circular scour depression about 4 diameters larger than the hemisphere, with its flat bottom about 20 cm below the adjacent sand level (Figure 2-12). In contrast, the hemi-oblate spheroid, when placed flat-side down on the bottom in 9 m of water, had a tendency to lift above the bottom on its upwave side (Figure 2-13). The shape of the object appeared to give it a hydrodynamic lift as the currents moved over it. "This lift caused the object to topple into its scour depression." As a result of this behavior the object moved from its original position and finally buried with its flat side at an angle to the surrounding bed. When placed in 4 m depth water just outside the surf zone these objects scoured more rapidly than in deeper water, but developed essentially the same scour patterns.

Two effective densities were used in the study of the burial of the 30 cm diameter by 60 cm long cylinders. This was accomplished by changing their internal masses so that their overall weight in air was 17 kg and 45 kg. The lighter cylinder rolled along the sea floor when planted in 9 m water depth. It rolled on and offshore with the passage of each wave, and moved about 40 m from its placement site before being trapped in one of its own scour depressions. It continued to roll around in its scour depression and by the second day, when it was removed, had enlarged the depression to over 3 m long and about 18 cm deep. In contrast, the heavy cylinder when planted in 9 m of water did not roll, but immediately developed a significant scour pattern. Within 1.5 hours, it was in a scour depression one-half of its diameter below the surrounding sand level, with a

scour radius about 25 cm wide around it. The waves at the surface had a significant height of 1.2 m and a period of 10 seconds.

2.3 Studies of Mine Burial Near Sydney, Australia

Two studies of mine burial were made off Sydney, Australia, in water depths of 11 m and 25 m. At the 11 m depth, the mine buried about 40% of its diameter in the first week, and complete burial occurred two months after emplacement during a period of rough water when 10 second period waves reached a height of about 3 m. At this depth, the bottom sediment was fine to median sand with median diameter of about 250 μm , and the mine was cylindrical with a diameter of 30.5 cm and length of 2.29 m (Mulhearn, 1995).

At the 25 m depth, the mine buried about 20% of its diameter in the first 10 days, achieved maximum burial of about 40% in 20 days under 4 m high waves, but did not attain complete burial during the three month experiment. At this depth, the bottom sediment was coarse sand with a median diameter of about 550 μm , and the mine was cylindrical, 52 cm in diameter, and 2 m long (Mulhearn, 1993a).

2.4 Naval Coastal Systems Center Studies

Measurements of the burial of cylindrical objects by wave action over fine sand bottoms in water depths of 8 m and 12 m were conducted by the Naval Coastal Systems Center, Panama City, Florida (Salsman and Tolbert, 1966). The measurements were designed to test an hypotheses “the tendency for cylindrical ground mines, under some conditions to ‘become a part’ of a seabed ripple pattern and thereby not bury completely.” The measurements showed the hypothesis to be wrong, but did show that these careful field measurements could provide valuable information on the burial characteristics of cylinders as a function of size.

Six right circular cylinders of concrete were made with diameters ranging from 15 cm to 91 cm, each with length three times its diameter. Their mass ranged from 20 kg to 4.3 metric ton, with density of 2.4 ton/m^3 . The six cylinders were placed in water depths of 12 m in January 1965 and measured 51 days later in March 1965, and then four of them were recovered and placed in water depth of 8 m on 16 March. At each depth, the cylinders were lowered to the bottom and oriented with axis parallel to the shore and prevailing wave crests. Reference rods were

driven into the bottom sand a short distance away from the cylinders to determine changes in general sand level.

At the 12 meter depth, after 51 days of Gulf Coast January to March wave action, the four smallest cylinders were completely buried, the 76 diameter cylinder was almost fully buried and the 91 cm cylinder was 70% buried. The magnitude of the burial depth increased with increasing cylinder diameter, where the burial depth is taken as the distance from the mean sand level to the bottom (keel) of the cylinder. In contrast, the percent burial, relative to the diameter of the cylinder, decreases with increasing size of cylinder. These burials were probably not associated with general changes of sand level as this change was only 4 cm, although it is possible that other changes took place over the 51 day period between observations. The measurements are likely associated with nearfield scour and burial by waves.

The first measurements at 8 m depth were made after a 3 day period of waves with height of 1.2 m and period of 7 seconds. In this case, none of the cylinders were completely buried, and the burial depth again increased progressively with cylinder size, while the percent burial varied inversely with size from 93% for the 15 cm cylinder to 45% for the 76 cm cylinder (Table 2-1). Observations continued through the spring and summer with measurements on day 35, 52, and 107, all showing practically no change associated with the small waves of this period. Small waves are typical for summer in the northern Gulf of Mexico. In September 1965 two full scale hurricanes, Betsy and Debbie, moved through the gulf, generating 4.6 m high, 11 sec waves at the 8 m deep site. Poor visibility prevented measurements until 2 November, 231 days after placement and a month and one-half after the hurricanes. Most of the reference rods were lost, but it was estimated that the general sand level in the area had accreted 13 cm. Three buried cylinders, 15 cm, 61 cm and 76 cm diameter were found and their burial depths measured (Table 2-1, after hurricanes). Again, the depth of burial to the keel of the cylinder increased with cylinder size, with a burial depth of 104 cm for the largest cylinder. The burial thickness covering this 76 cm diameter cylinder was 38 cm.

The burial measurements for these cylinders is in agreement with the mechanics of scour and burial discussed in §3.2. It is shown there that the scour depth is a function of the ratio d_o/D , where d_o is the wave orbital diameter and D is the cylinder diameter. The agreement of these field measurements with scour

phenomenon suggests that mine burial in fine sand, even under hurricane waves, follows a scour, role and burial sequence rather than one associated with liquefaction of the sand bed.

B TIDAL/RIVER FORCING AND IMPACT BURIAL

Following World War II a number of observational reports were made and some detailed field studies conducted on mine burial in the muddy and mixed sediments of tidal channels and tidal river entrances and in U. S. and British harbors (e.g., McMaster et al., 1955, p. 2-7; Exercise CURLEW, 1948). A study of the impact burial of MARK 25, HM MARK 36 and MARK 39 mines in York River, Virginia was carried out by Burt et al. (1952). These mines were dropped from aircraft in water depths of 9 to 21 m where the bottom sediment was predominantly clayey silt with some fine sand. In consistency, the material generally ranged from soft plastic on the surface of the bottom to firm mud at about 40 to 60 cm below the bottom. The mines were buried to various depths. The MARK 25 and HM MARK 36 mines released from level flight, were the least buried (about one-half), while up to about 50% of the MARK 39 mines were totally buried. Of the three types, the MARK 25 and HM MARK 36 are dropped by parachute from level flying aircraft, while the MARK 39 has a streamlined nose and is delivered without parachutes from either level flight or diving aircraft. The greater penetration resulted from MARK 39 mines released by diving aircraft at the lowest altitude (about 1500 to 2100 ft).

2.5 Narragansett Marine Laboratory Studies of Mine Impact and Burial

Beginning in May 1954 the Narragansett Marine Laboratory, University of Rhode Island, conducted studies of mines dropped from the water surface in a variety of environments in the vicinity of Rhode Island Sound and adjacent entrance channels (Donohue and Garrison, 1954; McMaster et al., 1955). Ten HM MARK 36 mines were deployed over a period of about one year. Initially a second mine was placed near that laid by free fall through the water column. However this practice was not productive and was discontinued. The mines were observed by divers at the time of placement and at later times. Determination of roll characteristics was aided by painting the mines with 15 lettered horizontal stripes. Changes in mine heading were obtained by compass bearing.

The environments of the mine lay areas are typical for the sounds and inlets along the glaciated coast of New England. The bottom sediments range from gravel through sand to mud and the details of their sedimentary and geotechnical characteristics are given in reports by Garrison and Frazier (1954) and Frazier and Miller (1955). The environments studied can be characterized in terms of exposure to waves and currents and type of bottom sediment as: 1) partially exposed coastal waters subject to moderate wave action with bottoms of fine sand to coarse gravel; 2) lee of islands and passages between islands subject to tidal currents; and 3) entrance channel to a bay subject to tidal currents. The characteristics and mine behavior for these three environments are summarized in Table 2-2 and discussed below.

Mines placed in sandy areas partially exposed to waves from the open sea, behaved in a manner similar to that described under §A (wave forcing). The first mine, dropped on very fine sand in 5 m depth, scoured and buried one-half its diameter in 6 days and was removed. The second mine was dropped and lay across the crests of coarse sand ripples in depth of 12 m. The mine changed its heading to parallel the ripple crests and was partially buried when removed after 13 months. The third mine, placed on a gravel bottom in 11 m depth, remained on the surface of the bottom. This mine occasionally rolled and changed heading, and only formed large scour depressions during a hurricane.

Two mines were placed in environment 2, characterized by strong tidal currents in depth of 11 m between and in the lee of islands. The first mine rolled 45° and then developed an asymmetrical scour pattern with a scour trough in the direction of the strongest tidal current. The mine became partially buried and was removed on day 20 (Figure 2-14). The second mine was placed during slack water in the scour hole (Quicks Hole) between two islands where the bottom consisted of tightly bound mussel shells and gravel. No visible scour occurred during 2 knot current, and the mine was removed in 24 hours.

Three mines were deployed in environment 3, the outer, mid and inner portion of the long entrance to Narragansett Bay, in the channel west of Conanicut Island. The mine in the outer channel was dropped on a bottom of muddy sand with gravel in depth of 17 m. Under 1.5 knot tidal currents scour began immediately, particularly at the ends of the mine. During slack water the scour depressions filled with a fluid mud having a density of 1.26 gm/cm³ (Figure 2-15). A second mine

was placed in the channel midway between the sound and Narragansett Bay, where the bottom at 11 m depth was cobbles, pebbles and shell. This mine gradually (about 2 weeks) developed a complex scour pattern similar to that shown in Figure 2-14.

The third mine was dropped from the water surface in the inner entrance channel at a water depth of 8 m where the bottom consisted of shell fragments over a clayey-silt mud with a wet density of about 1.45 and a moisture content of about 80%. The mine struck the bottom nose down, and the force of impact imbedded about one half of the mine's bulk in the bottom mud. The sediment displaced by the plowing action of the mine drop partially covered the mine. There was very little scour in this stiff mud and the mine remained with little modification of the initial form from day 0 until it was removed on day 372 (Figure 2-16).

2.6 Recent Studies of Impact Burial and Penetration

Bottom mines planted from ships and aircraft fall through the air, enter the water column, fall through it, and strike the bottom with an impact determined by their momentum and orientation upon striking the bottom. The fall through both media may involve tumbling and gliding unless there are tail fins or other provisions for dynamic stability. And, at each interface, air/water and water/sediment, the impact has two types of forces, the translational inertia associated with the fall to the interface and rotational inertia associated with the angle of impact (Figure 2-17). Given the initial conditions of mine size, shape, mass and initial orientation and velocity, plus the fall distances in air and water and the bottom sediment characteristics, it is possible to develop mechanical relations for the impact burial of mines.

It is also apparent that the large number of possible initial conditions makes it impractical to seek an exact solution to impact burial for all mine types. As a consequence, research must look for general solutions that apply to typical cases. Past and ongoing research on impact burial include Satkowiak (1987), Mulhearn (1993b), and Chu et al. (2002). Three basic fall patterns have been identified (Figure 2-17) *straight* with the long axis of the mine aligned with the fall trajectory, *flat* with the longitudinal axis perpendicular to the trajectory, and *spiral* where the mine orientation oscillates between the straight and flat patterns. The highest fall velocities and deepest impact burials occur when the mine falls in the straight fall pattern. Regardless of fall pattern there is little impact burial on clean sand

bottoms, while there will always be some impact burial on mud bottoms and total burial on fluid mud bottoms.

Table 2-1. Burial of cylindrical objects off Panama City, Florida. ^a

Cylinder Diameter ^b	Burial in 12 m water depth ^c		Burial in 8 m water depth ^d			
	day 51		day 3		after hurricanes ^e	
D, cm	η , cm	%	η , cm	%	η , cm	%
15	36	240	14	93	28	187
30	41	137	-	-	-	-
46	53	115	31	67	-	-
61	69	113	32	52	88	144
76	71	93	34	45	104	137
91	64	70	-	-	-	-

a Source: Salsman and Tolbert, 1966; U. S. conventional units converted to nearest cm and m. Burial is expressed as vertical distance η from the mean sand level in the vicinity of the object to the bottom (keel) of the object. Protrusion of object above sand level is $D-\eta$ where D is diameter. Burial thickness over object is $\eta-D$. Percent burial is $100 \eta/D$.

b Right circular cylinders (concrete), length 3 times diameter, density 2.4 metric ton/m³.

c 12 m depth, 0.181 mm sand; by day 51 sand level had lowered 4 cm, winter waves 20 Jan. - 12 Mar. 1965.

d 8 m depth, 0.174 mm sand, by day 3 sand level constant, waves 1.2 m high, 7 sec.

e 8 m depth following hurricanes Betsy and Debbie with 4.6 m high 11 sec waves, with an estimated sand level accretion of 13 cm.

Table 2-2. Mine burial experiments in Rhode Island Sound and adjacent channels. ^{a, b}

Environment and Forcing	Designation	Depth m	Bottom Sediment	Remarks:
1. Partially exposed coast of Rhode Island Sound in lee of Block Island. Forcing: waves	Baker beach ^b	5	very fine quartz sand	Dropped October 1954 with no penetration. When removed after 6 days mine had scoured and buried one-half its diameter.
	Baker gravel ^a	11	coarse gravel with no sand	Mine dropped May 1954 with no penetration. Remained on surface of bottom rolling, changing heading and forming, scour depressions during hurricane.
	Baker sand ^{a,b}	12	coarse quartz sand	Mine dropped June 1954 with no penetration. Initially lay across 75 cm long ripples, gradually changed heading to parallel ripple crest was partially buried when removed after 13 months.
2. Lee of Nantucket Isl. in Nantucket Sound. Forcing: tidal currents, 2 knot ^c max. Island passage between Buzzards Bay & Vineyard Sound. Forcing: tidal currents, 2 knot ^c	Fox ^a	11	fine sand w/shell	Mine dropped June 1954 with no penetration, rolled 45° and rapidly developed asymmetrical deep scour pattern. Partially buried when removed at day 20 (Figure 2-14).
	Love ^b	11	mussel shell layer over sandy gravel	Mine dropped in August 1954 and did not penetrate layer of shell. Mussel shells prevented scour under 2 knot current. Mine removed in 24 hours.
3. Entrance channel to Narragansett Bay, west of Conanicut Isl. Forcing: tidal currents ~ 1 knot ^c (with surge during Hurricane Coral Sept. 1954)	How ^b (outer channel)	17	muddy sand w/gravel	Mine dropped June 1954, no penetration, heading broadside to current. Developed large scour depression with deepest holes at mine ends. During slack water mud filled depression (Figure 2-15). Removed in 65 days.
	Mike ^b (mid channel)	11	cobbles, pebbles and shell	Mine dropped June 1954, no penetration, but developed complex scour pattern with some burial, similar to Figure 2-14.
	Able ^{a,b} (inner channel)	8	shell fragments over clayey silt	Mine dropped from surface May 1954 and penetrated one-half of mine's bulk into bed. Little change during one year (Figure 2-16).

^a Source Donohue and Garrison, 1954.

^b Source McMaster et al., 1955.

^c knot: 1 nautical mile per hour \sim 50 cm/second.



Figure 2-1. HM MARK 36 mine on stern winch of a DUKW in preparation for deployment off Scripps in 1953. The subsurface buoy is to aid in location on the seafloor. [from Inman and Jenkins, 1996]



Figure 2-2. Reference rod used to determine sand level change at mine site in depth of 9 meters on the shelf off Scripps. Brass rod is 1 cm diameter and 122 cm long, approximately 30 cm exposed. Ripple wavelength is about 7 cm in sand of median diameter 125 μ m. [from Inman and Rusnak, 1956]

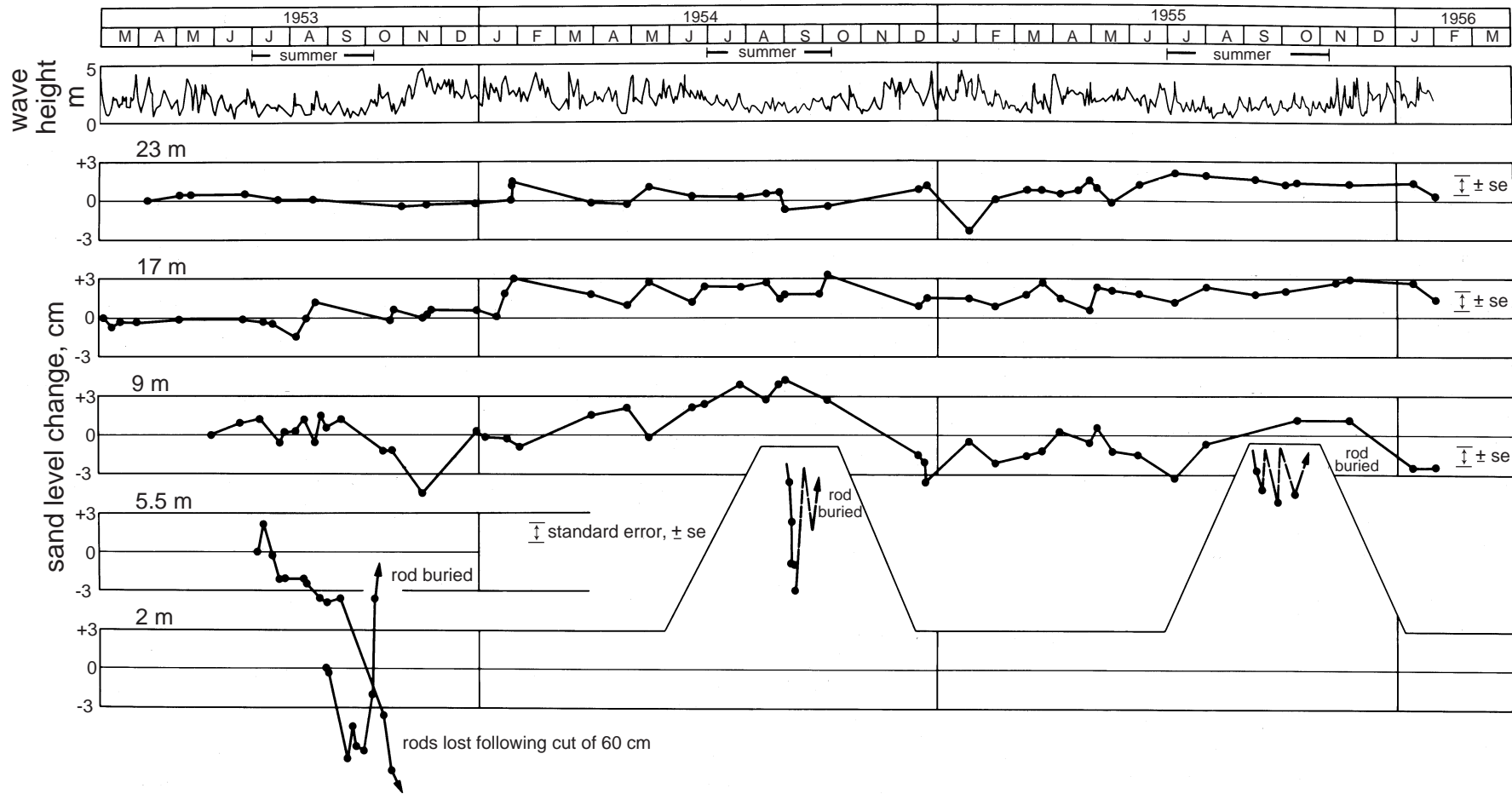

Figure 2-3. Changes in sand level on the beach and shelf off Scripps Institution of Oceanography, depths relative to MSL, wave heights are for significant breakers measured from the beach. [from Inman and Rusnak, 1956]



Figure 2-4. HM MARK 36 mine at 17 m depth, two and one-half months after laying. [Inman negative 277-42, 1953]

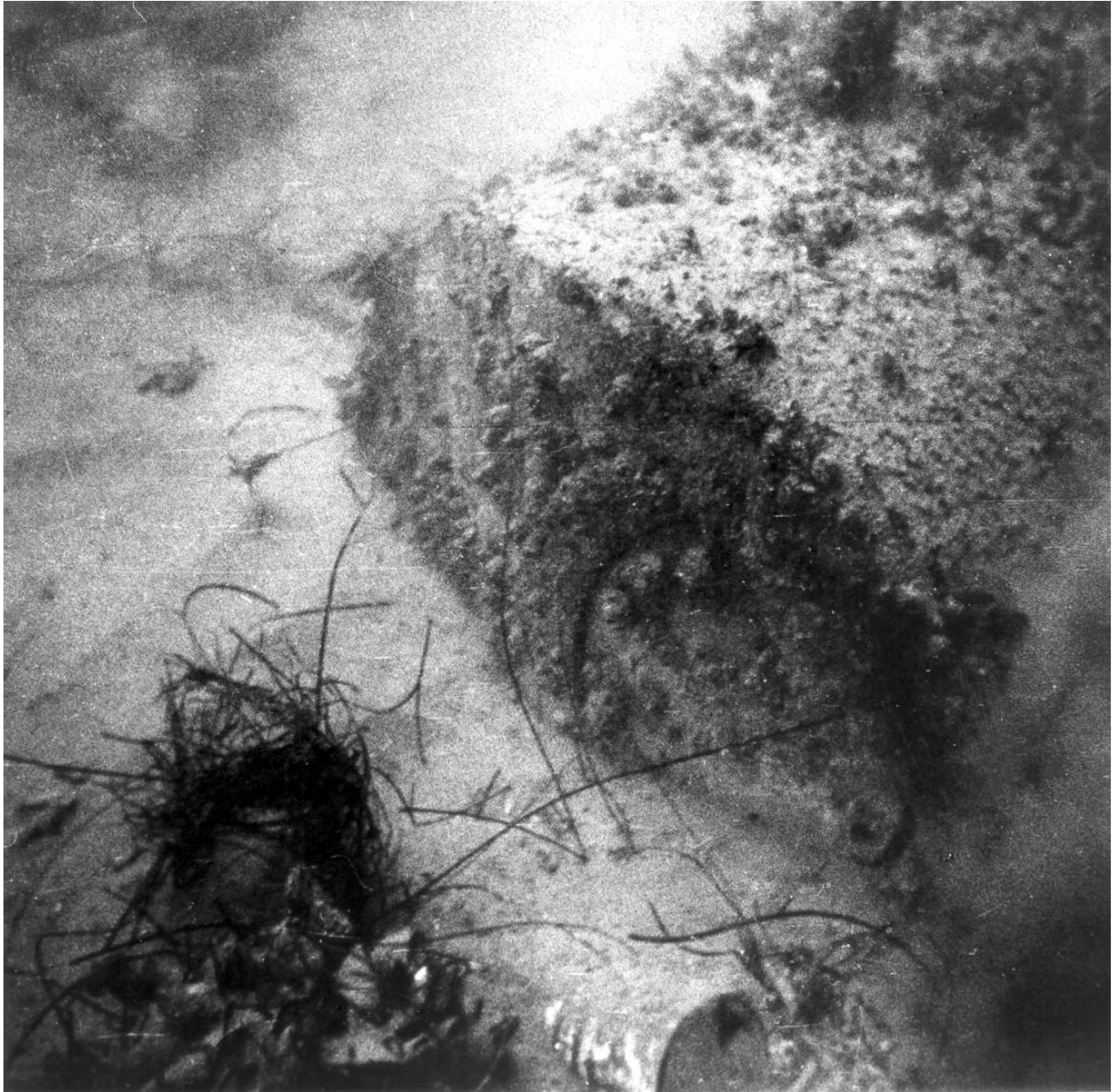

Figure 2-5. HM MARK 36 mine at 17 m depth, 4 months after laying, about one-half buried. [Inman negative 276-13, July 1953]



Figure 2-6. HM MARK 36 mine at 17 m depth, 9 months after laying, with major scour depression that has scavenged an aggregate of coarse material. Mine completely buried several days after this photograph. [Inman negative 339-3, Jan 1954]



Figure 2-7. HM MARK 36 mine at 23 m depth about three-quarters buried, nine months after laying, just before total burial as shown in Figure 2-8. [Inman negative 343-1, 1954]

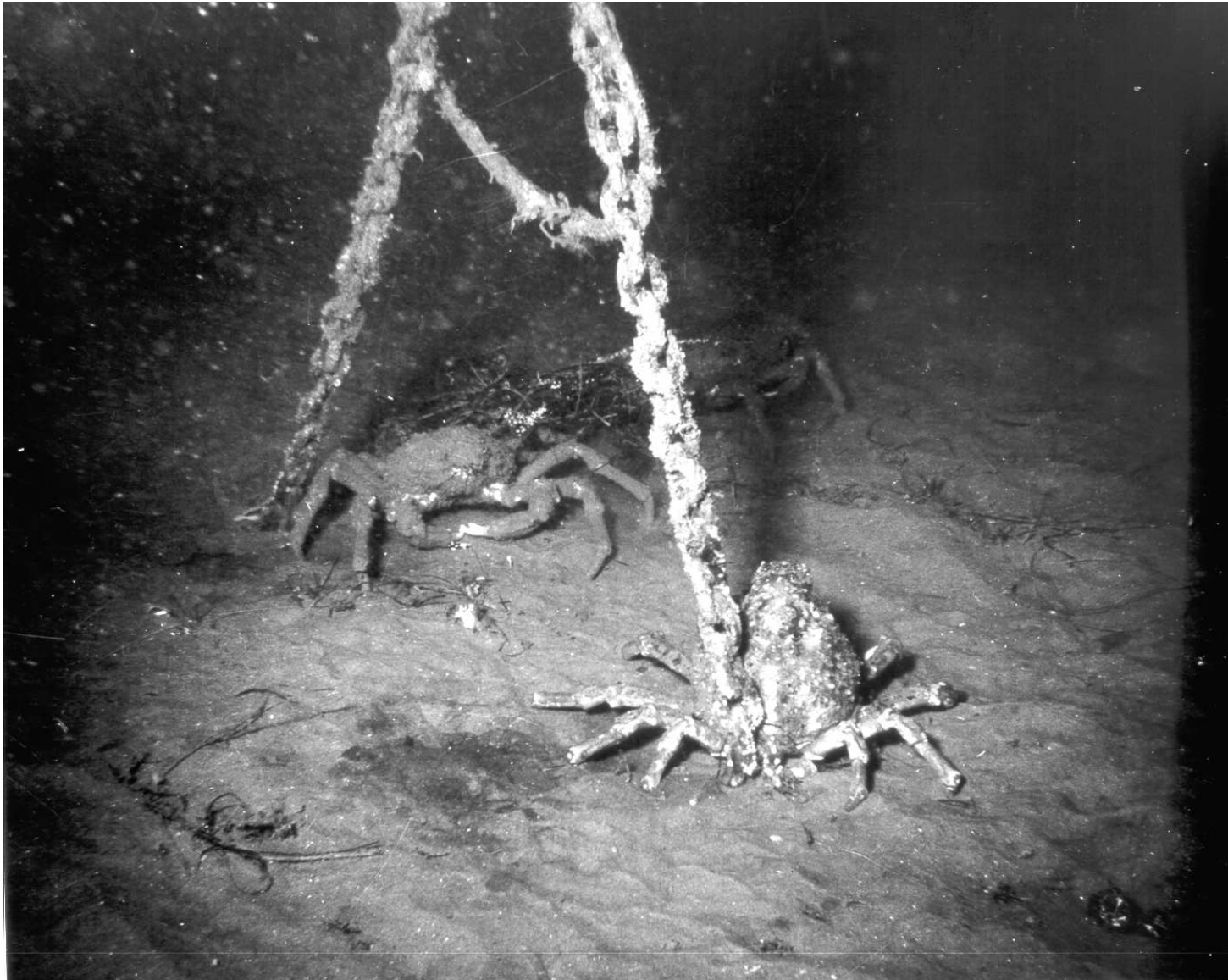

Figure 2-8. Buoy chains mark location of buried mine, HM MARK 36, water depth 23 m.
[Inman negative 483-8, Oct 1955]

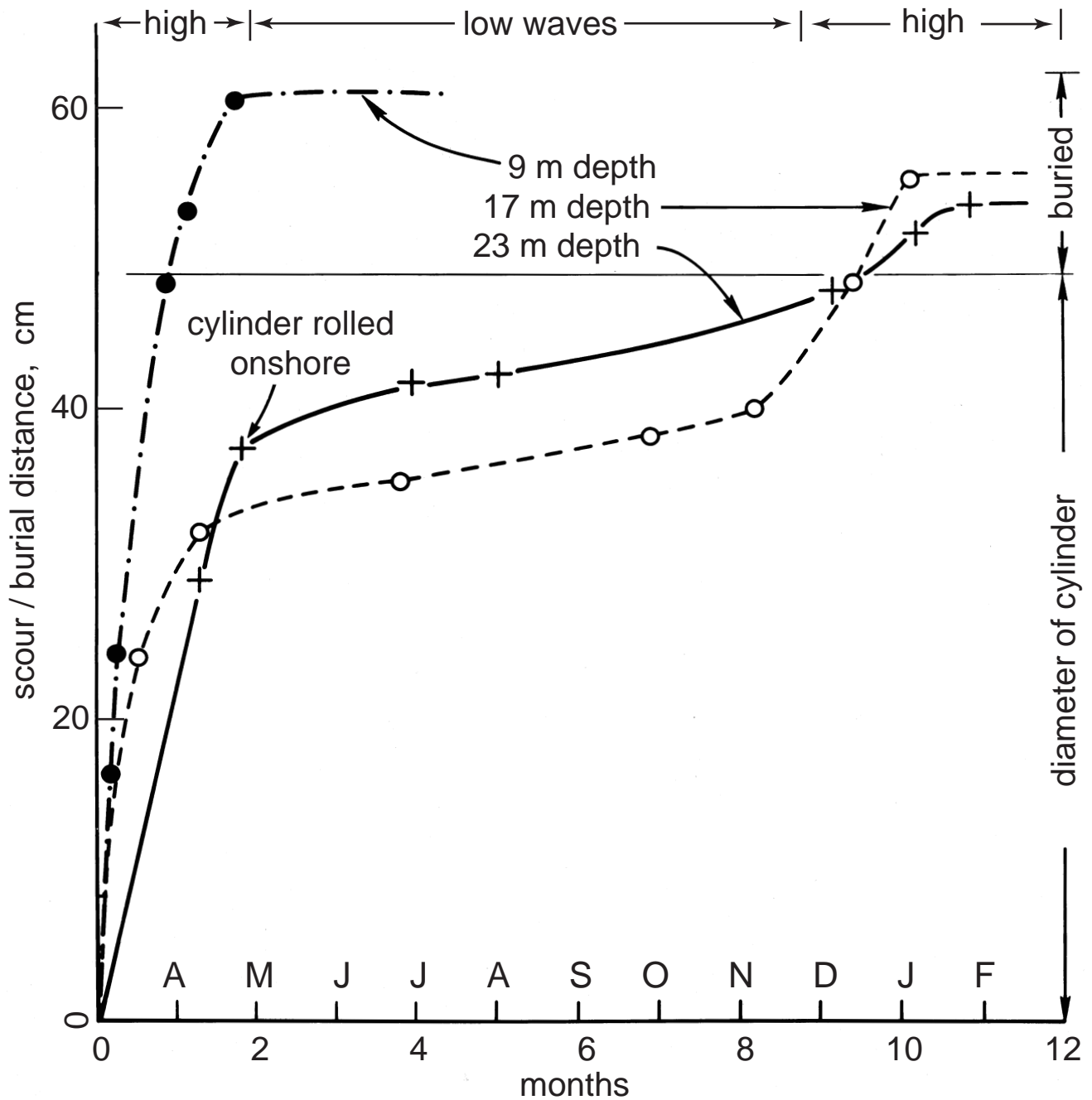

Figure 2-9. Rate of burial of HM MARK 36 mines (47 cm diameter) planted on the sandy shelf off Scripps Beach in March 1953. Burial was by scour and roll, as farfield sand level changes did not exceed ± 3 cm (see Figure 2-3). [after Inman and Jenkins, 1996]

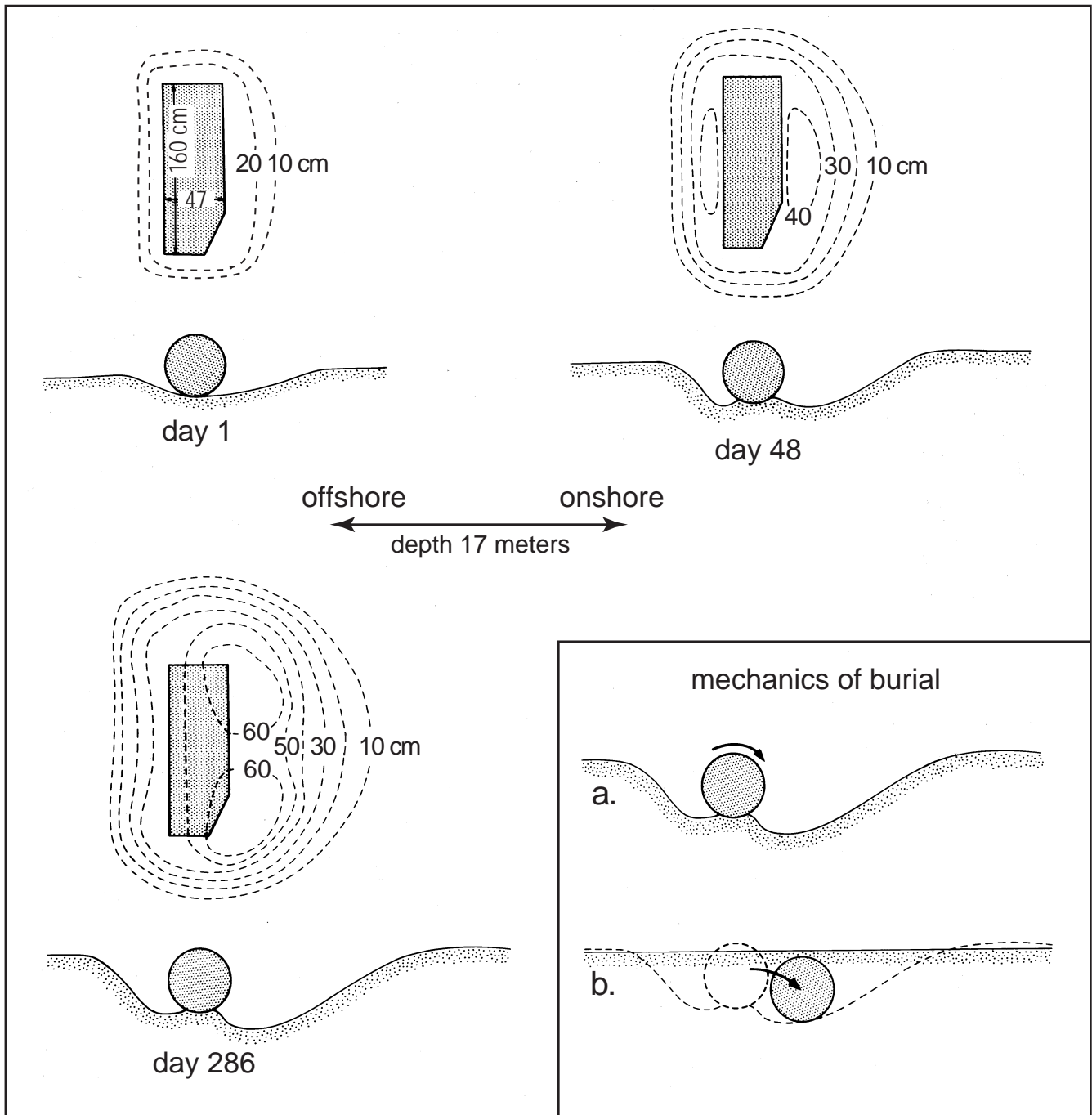

Figure 2-10. Scour and burial of cylindrical mine by wave action over a fine sand bottom off Scripps Beach, La Jolla, CA [after Inman and Jenkins, 1996]. Note vertical exaggeration in profile view.



Figure 2-11. Sandy bottom covered to thickness of 40 cm by egg casings of squid. Water depth 23 m, site of buried HM MARK 36 (cf. Figure 2-8). [Inman negative 457-20, 21 Dec 1954]

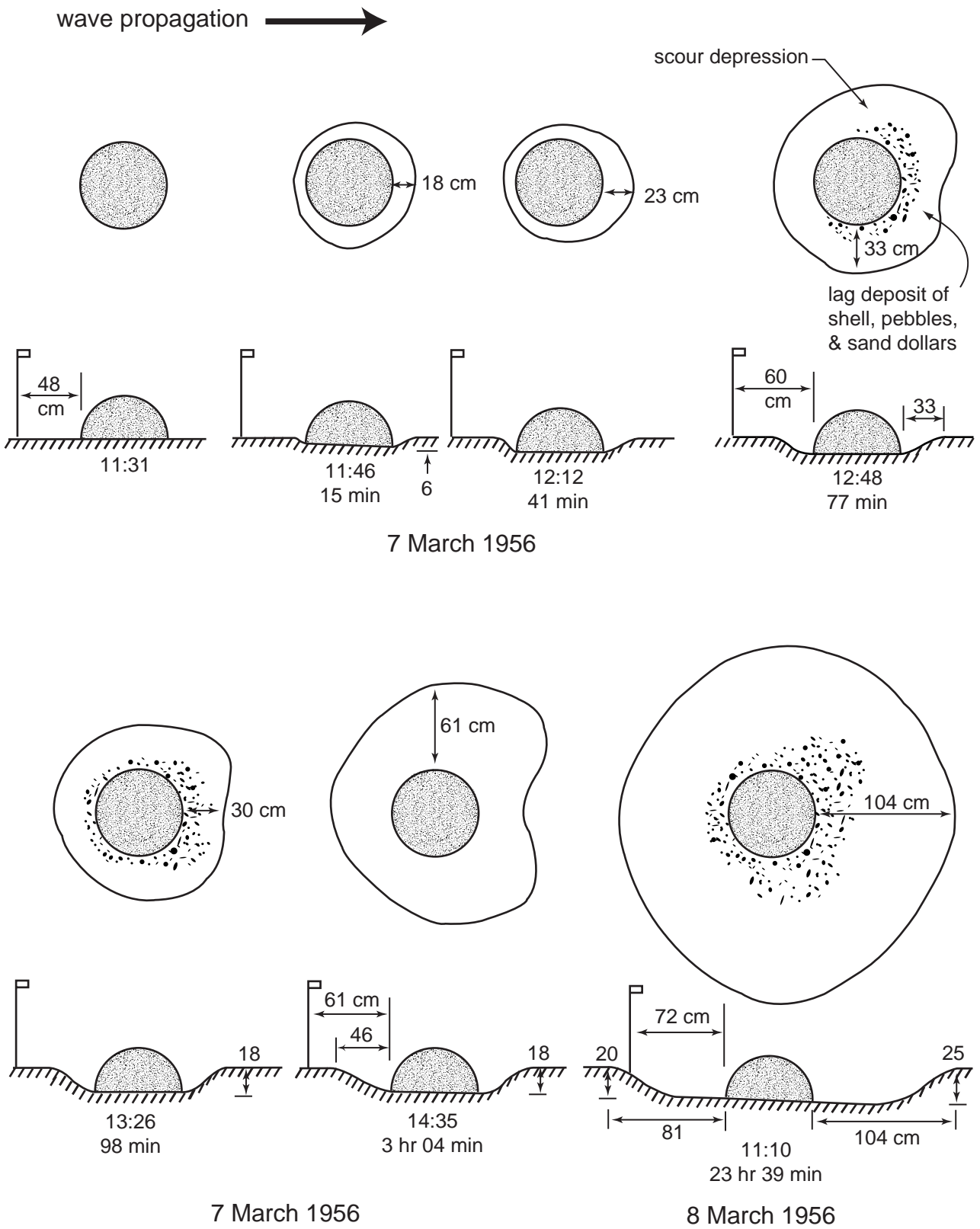

Figure 2-12. Scour and movement of a 61 cm diameter hemisphere under wave action in 9 m water depth, total interval ~ 24 hours. [modified from Dill, 1958]

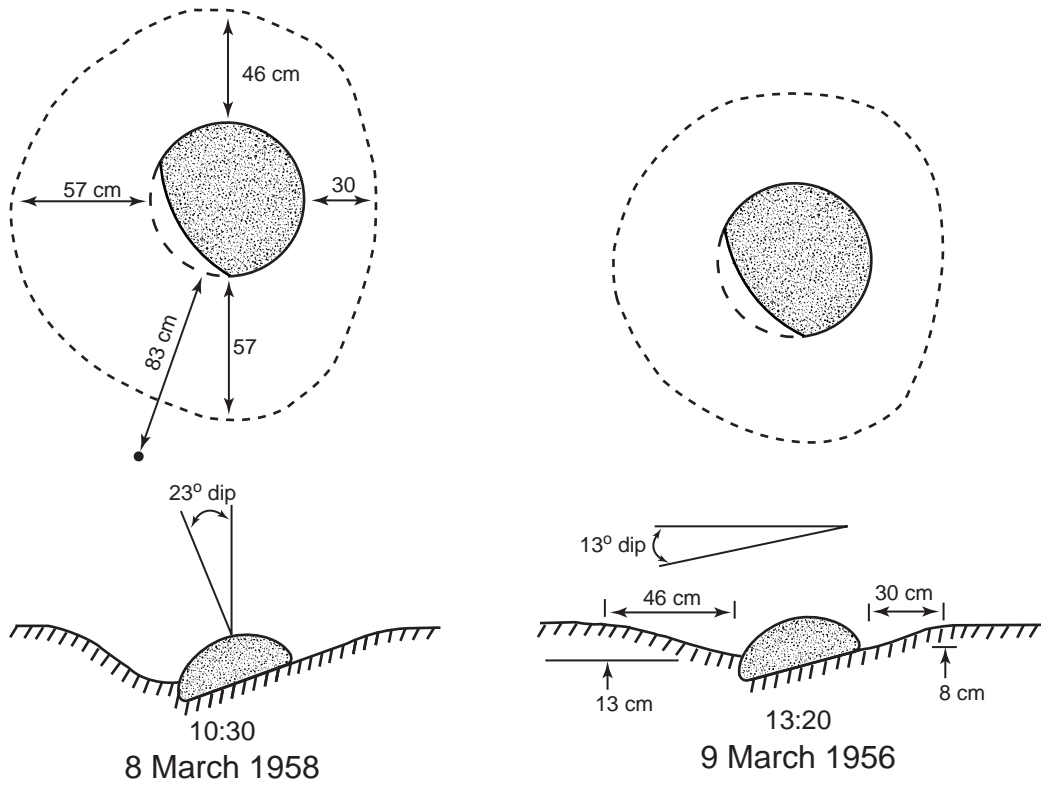
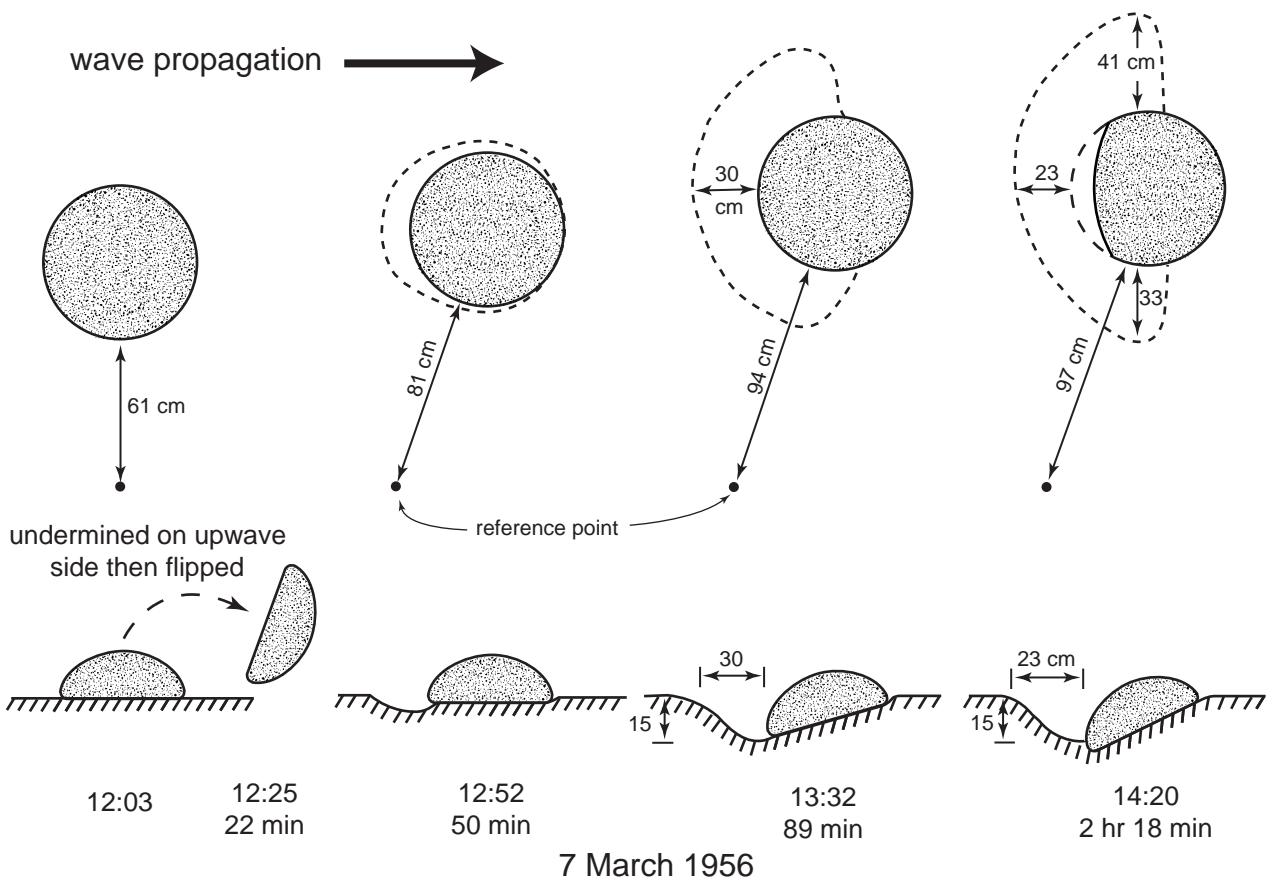
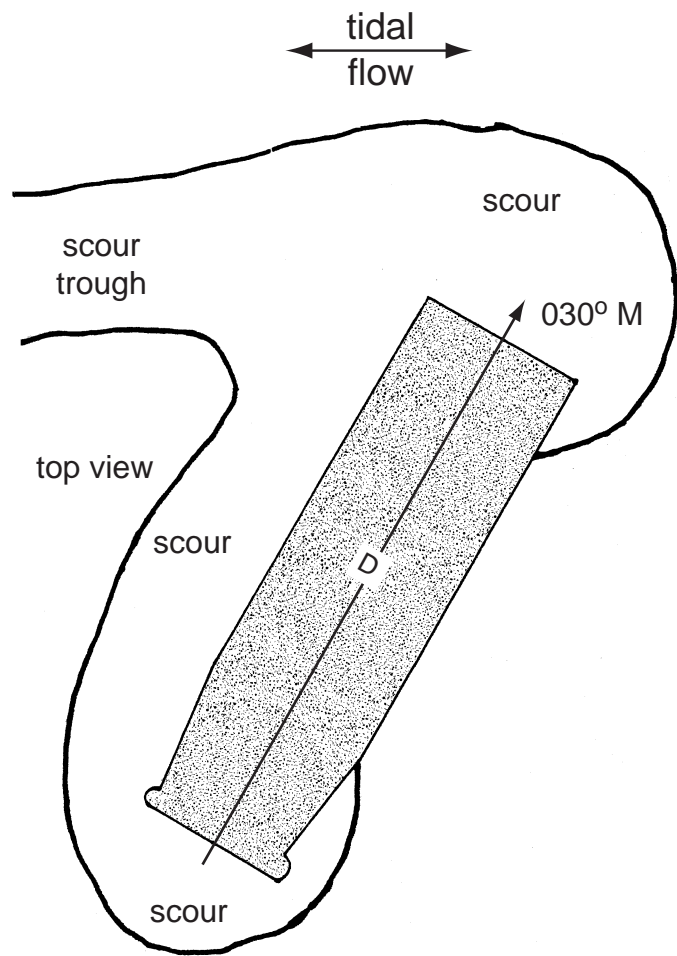

Figure 2-13. Scour and burial of a 61 cm diameter hemi-oblate spheroid under wave action in 9 m water depth, total interval ~ 49 hours. [modified from Dill, 1958]



day 20

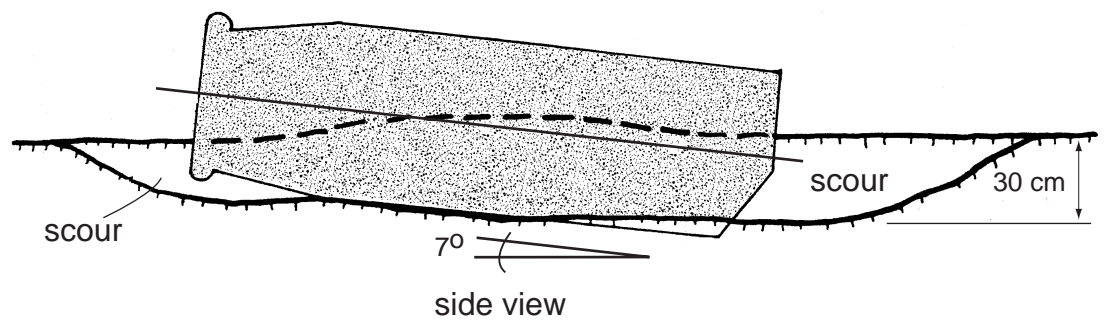
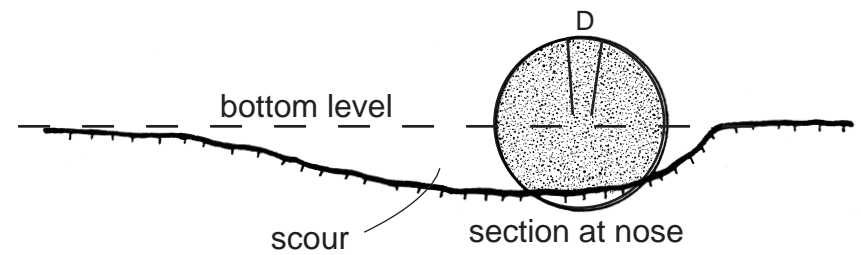
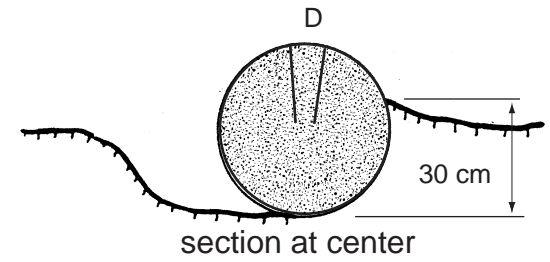

Figure 2-14. Scour pattern for HM MARK 36 mine in oscillatory tidal current, depth 11 m, bottom fine sand with shell. [after Donohue and Garrison, 1954; Fox area]

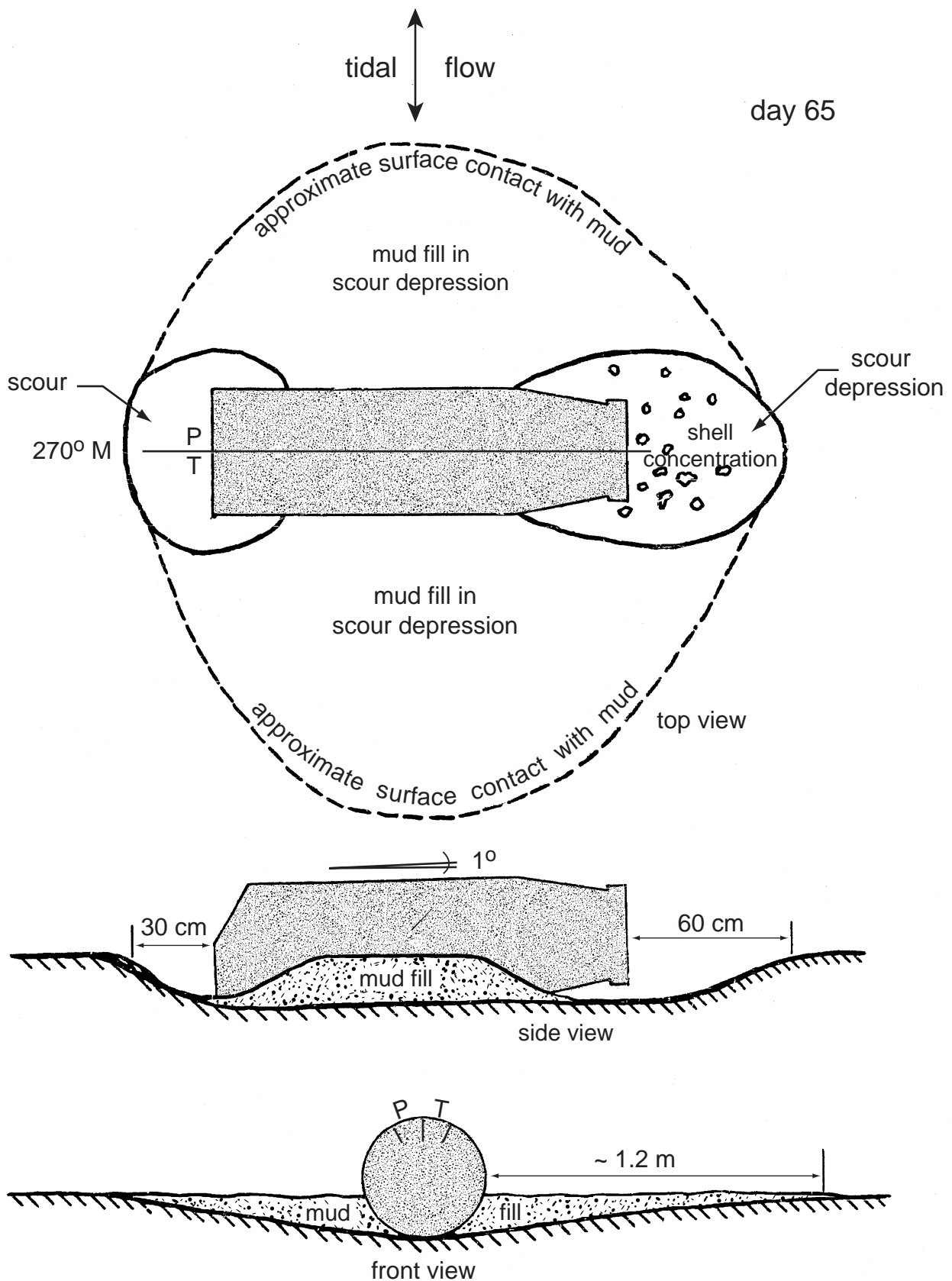

Figure 2-15. Scour pattern of HM MARK 36 mine in oscillatory tidal current, depth 16 m, bottom sand and gravel with mobile mud fill. [after McMaster, et al., 1955; How area]

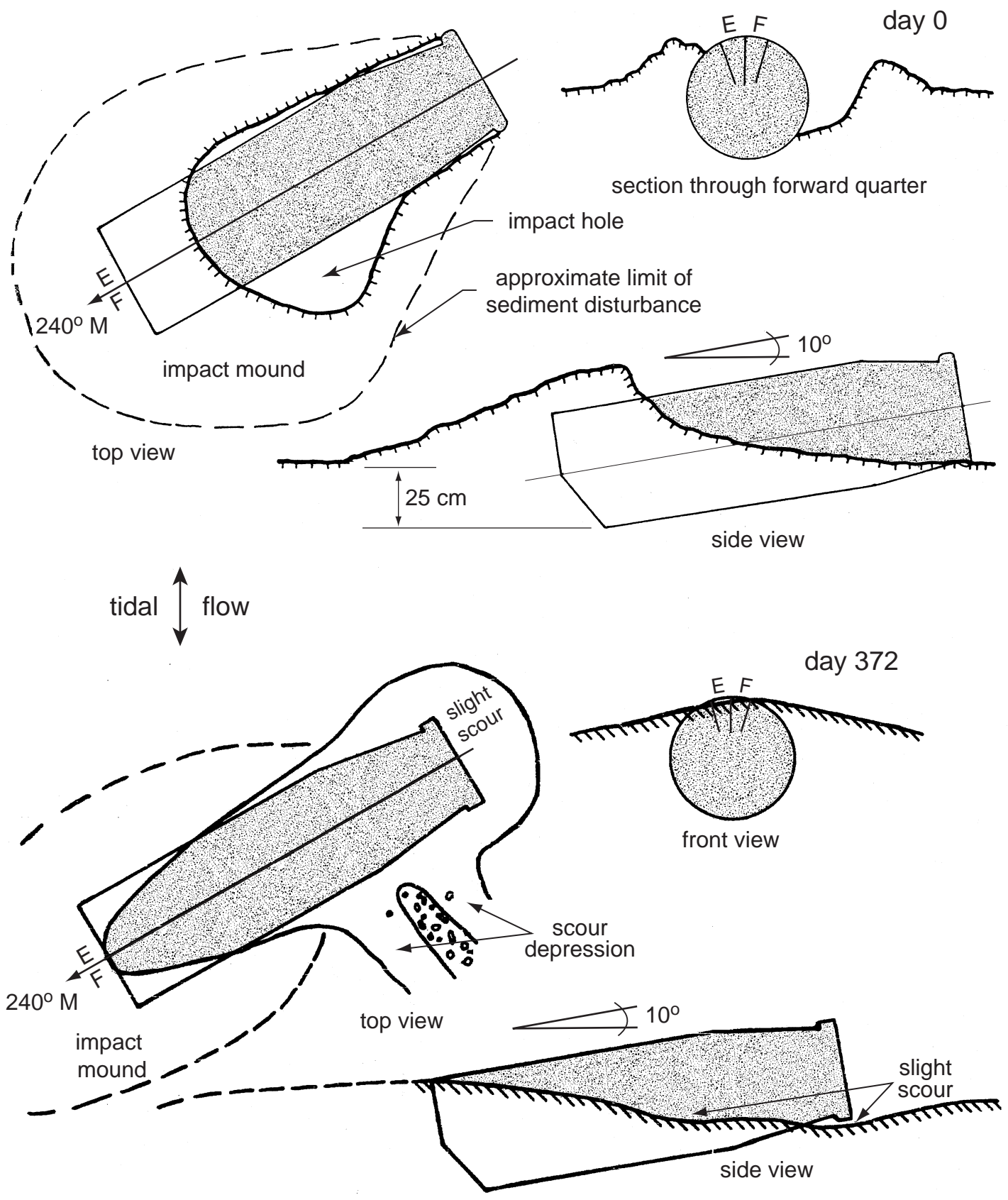
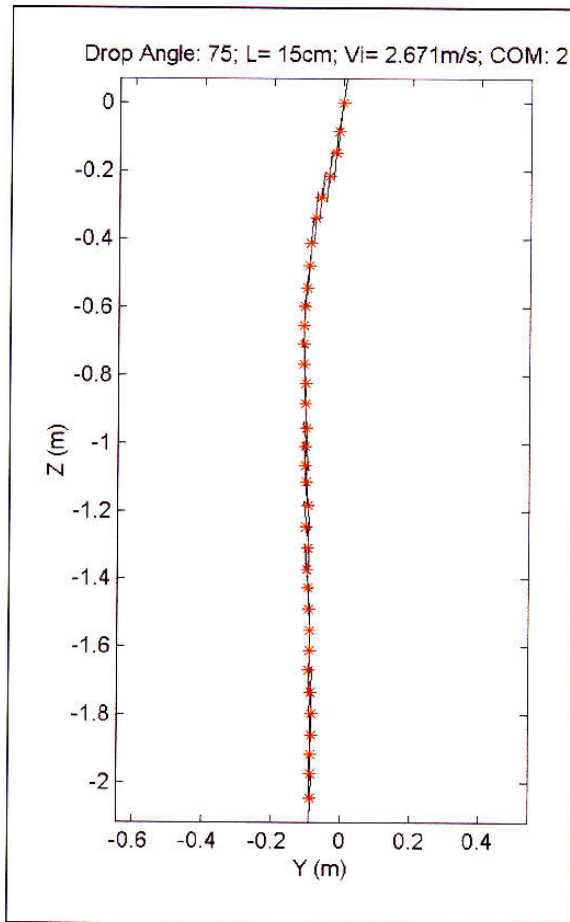
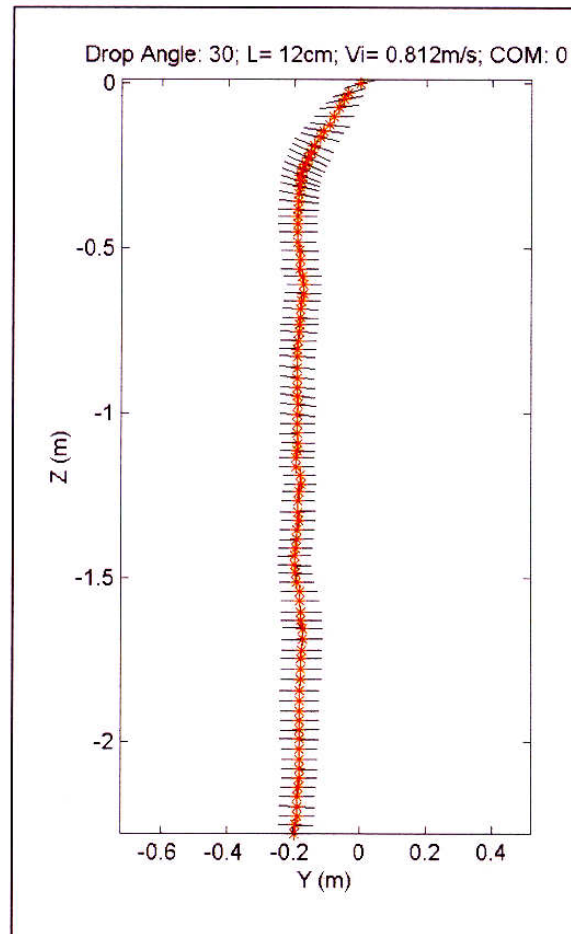

Figure 2-16. Scour pattern for HM MARK 36 mine in oscillatory tidal current, depth 8 m, bottom shell fragments over clayey silt [day 0 after Donohue and Garrison, 1954; (Able area); day 372 after McMaster et al., 1955]

a. Straight



b. Flat



c. Spiral

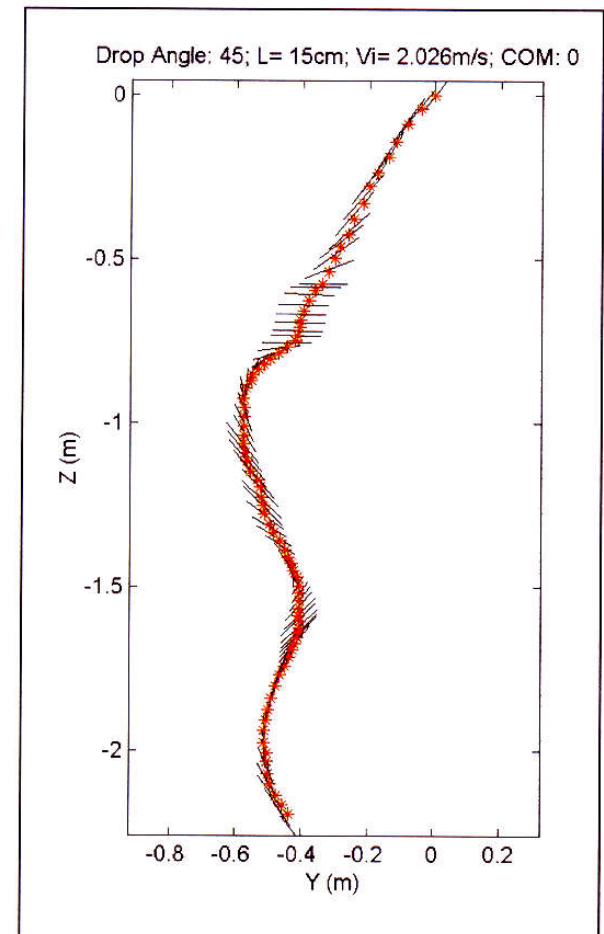

Figure 2-17. Fall patterns for a model cylindrical mine selected from the experiments of Chu et al. (2002).
[with permission]

3. MECHANICS OF SCOUR AND BURIAL

Scour is the change in bed configuration due to the change in flow pattern around an object such as a bottom mine placed on or near the surface of a movable bed. The presence of the object modifies the flow pattern around the object, generating vortices that locally increase and decrease the bottom flow stresses. The vortices cause depressions and mounds to form on the bed surface. Objects placed on beds where the flow was causing no apparent motion can locally increase the bed stress behind the object and induce bed motion and scour. The scour phenomenon occurs in unidirectional and oscillatory flow and in fluids ranging from air to water to sediment laden turbidity currents and pyroclastic flows. Obstacles producing scour range from millimeter size grains to topographic features many meters high and kilometers in length, while the resulting bedforms range from sand streaks and ripples to large desert dunes and to scour moats and sediment drifts around seamounts in the deep ocean (Inman and Jenkins, in press 2002a).

We are primarily concerned with scour around mines planted in nearshore waters and near beaches where the flow is both unidirectional and oscillatory. Scour naturally occurs wherever a larger object occurs on or protrudes from an otherwise smaller grained bed (Figure 3-1). For example, a sea shell or a kelp-rafted rock on the seabed will form scour features ranging in size from rhomboid marks around small objects to crater-like crescentic depressions twice the size of the shell or rock. Above the waterline, wind-blown scour features form around kelp clumps and rocks on the beach (Figure 3-2), while accretionary dunes and sand shadows form around outcrops on the coastal desert floor (Bagnold, 1941).

Bed irregularities that locally concentrate nearbed vorticity may elevate bed shear stress and initiate grain motion, leading to local bed scour, including bumps and depressions on the bed itself (Figure 3-3a). Once initiated, a pattern of scour may spread down current in the form of a growing field of current ripples (Figure 3-3b, c, d), while vortex ripples under wave action may spread both against and with wave propagation from a single initiating irregularity in the bed (Inman and Bowen, 1962; Tunstall and Inman, 1975).

Scour patterns associated with single bluff bodies placed on or extending from the bed are the most commonly studied. There is an extensive engineering literature of the scour around the piles of bridges and piers (e.g., Collins, 1980;

Chiew and Melville, 1987; Raudkivi, 1990). In sedimentology, the interest usually has been in the scour pattern around individual objects, referred to as *scour marks* (e.g., Pettijohn and Potter, 1964; Reineck and Singh, 1975) and as *obstacle marks* in studies by Allen (1984, 1985). Allen further subdivides obstacle marks into *current crescents*, *current shadows* and *scour-remnant ridges*. It appears that current crescent and *crescentic scour mark* are the most general terms for the crescentic feature formed around an object on the bed, and that the feature may be either erosional as in Figure 3-1, or accretional as in desert dunes. The appearance of other associated features such as current shadow, scour-remnant ridges (e.g., Figure 4-12) and ripples are wake phenomena that depend upon the height to width aspects of the object, the nature of the flow system, and the type of sediment.

Characteristics of the flow around a vertical cylinder, such as a bridge pile in steady currents, have been investigated extensively (e.g., Shen et al, 1969; Breusers et al, 1977). It has been found that a horseshoe vortex above the scoured bed is a dominant factor in the scour process, and that the vortex has a close relationship with the bed profile near the cylinder. The vortex behavior caused by the object is thus an important factor to consider in the estimation of bed scour as described under §3.1.

Relatively few studies have been conducted on scour induced by waves and currents. Nishizawa and Sawamoto (1988) and Sumer et al. (1992) have studied the flow around a slender vertical cylinder under waves using flow visualization techniques. Continued scour around objects on a sand bed usually leads to complete burial of the object. Shells and rafted objects dropped to the sea floor may eventually bury and disappear if the sand bed has sufficient thickness (e.g., Inman, 1957, Figure 20, 21). Studies most relevant to mine scour and burial are summarized in the preceding section (§2).

3.1 Scour Mechanics*

The scour phenomenon around objects differs from other types of sediment flux in that the presence of an object on or near the bed induces local changes in an otherwise uniform pattern of bed stress, thereby causing local patterns of

* Parts of this section are excerpted from Inman and Jenkins (in press 2002a)

erosion and/or accretion that may differ from the general bedform pattern. The object may be either blunt (bluff body) or streamlined and the resulting scour pattern may be erosional, depositional, or both. Scour develops from a variety of mechanisms whose relative importance depends upon the scale and intensity of the flow and the relative size and shape of the obstacle. The most common and largest bedforms result from scour around bluff bodies where the formation of a horseshoe vortex generates a scour hole that begins on the upstream side, wraps around the object, and extends downstream as trailing vortex filaments (Figure 3-4) as described below.

The mechanics of the scour around a body are inherent in the vorticity field generated when a fluid moves over a bed or solid surface (Schlichting, 1979; Raudkivi, 1990). For example consider the velocity profile above the bed and up current from an object on the bed (Figure 3-4). The shear near the bed in the bottom boundary layer generates vorticity between the layers of differing flow velocity, creating a vorticity sheet. *Vorticity* is the angular momentum of a fluid element, while a *vortex* is the arrangement of many of these fluid elements into a pattern of angular motion.

The flow disturbance of the obstacle creates a stagnation point (s') at the bed interface upstream of the obstacle. The bed vorticity in the approaching flow collects at the stagnation point forming a local excess of vorticity that organizes into a *forward bound vortex* (Figure 3-4). This moves the stagnation point (s) upstream of the vortex. The forward bound vortex initiates the scour process by causing intense velocity shear stress at the base of the obstacle. The incoming vorticity from the flow builds up in the bound vortex and the excess leaks around the base of the cylinder forming a pair of *trailing vortex filaments* on either side of the obstacle. The bound vortex with its pair of trailing filaments form a vortex system known as a *horseshoe vortex*. The trailing vortex filaments extend the region of scour from the upstream base of the obstacle, around the sides, and downstream. As the trailing filaments extend downstream, the vorticity of the filaments diffuse into the interior of the fluid thereby slowing the filament rotation and weakening the shear stress on the bed. Consequently the scour diminishes downstream of the obstacle forming a scour pattern around the obstacle known as *current crescent* or *crescentic scour mark*.

In orbital wave flow the maximum depth of scour within the scour mark is a function of the *Strouhal* number defined as

$$St = \frac{u_m}{\sigma a} \approx \frac{d_o}{D} \quad (3-1)$$

where u_m is the orbital velocity, d_o is the orbital diameter, σ is the wave radian frequency, a is the mine radius at the sand level and $D = 2a$ is the corresponding mine diameter. For 3-dimensional mine shapes such as a MANTA mine the maximum scour depth, η_s , has a power law dependence on *Strouhal* number (Figure 3-5),

$$\eta_s/a \sim St^{0.58} \quad (\text{truncated cone}) \quad (3-2)$$

Because flow disturbances are stronger for 2-dimensional bodies, scour depth for a cylindrical mine such as HM MARK 36 follows a higher power law dependence:

$$\eta_s/a \sim St^{0.71} \quad (\text{cylinder}) \quad (3-3)$$

Equations (3-2) and (3-3) indicate that scour depth is a greater percentage of the characteristic radius of a mine for a small mine than for a large mine. This follows from the fact that there is a greater degree of flow separation with stronger vortical scour when the orbital diameter of the fluid oscillation is large in comparison to the diameter of the object.

The horseshoe vortex and its associated crescent scour are nearfield bedform responses that occur over distances of about two obstacle diameters. Further downstream the trailing filaments of the horseshoe vortex begin to entwine into a helical vortex system. At each crossover of the helical pairs (e.g., Figure 3-4), the induced velocities of the vortex system approach a null on the bed, allowing for complimentary depositional features such as ripple marks in the current shadow, downstream of the crescentic scour. The fully-developed horseshoe vortex is a

consequence of the scour depression. Therefore, once the scour erodes deeply into the bed, the scour depression becomes an *interactive* part of a fluid-bedform system where the bedform interacts with and extensively modifies the flow field above it.

3.2 Other Scour Mechanisms

Other scour mechanisms become important in very shallow water typical of the swash and backwash motion of wave runup on the beach face. These mechanisms are associated with thin flows where water velocity often exceeds the critical limit for wave propagation and where capillary waves become important. Also, in thin flows common “V”-shaped ship waves are formed by small objects and induce stress perturbations on the sediment bed. As a consequence, the beach face often shows rhomboid marks caused by one or more of the mechanisms associated with thin flow (Figure 3-6).

The flow regime over the beach face may be either *sub-critical* ($u < \sqrt{gh}$) or *super critical* ($u > \sqrt{gh}$) depending on the speed of the water u relative to the shallow water wave speed \sqrt{gh} , where g is the acceleration of gravity and h is the thickness of the flow and their dimensionless ratio u/\sqrt{gh} is known as the *Froude number* (Stoker, 1957; Whitham, 1974). In either case, the height of small obstacles such as shells, pebbles, and the feathery antennae of filter feeding organisms that protrude above the bed are of the order of the flow thickness. Super critical flow is readily perturbed by an obstacle on the bed and locally slowed to sub-critical flow by small oblique hydraulic jumps (Henderson, 1966) upstream of and extending downstream from the obstacle in a V-shaped pattern. The turbulence of the hydraulic jump scours a corresponding V-shaped erosion pattern around the obstacle, often made strikingly visible by exposure of dark minerals in the laminated beach sand, similar to that shown in Figure 3-6. Intersection of adjacent V-shaped jumps form the characteristic diamond pattern of the rhomboid ripple. These marks are distinguished by their long scour trail and because the vertex of the V-shape is always upstream of the obstacle, much like the crescentic scour of larger obstacles under sub-critical flow conditions. However, the large super critical rhomboid marks are less common than would be expected because super critical flow over sand beaches rapidly develop *backwash ripples*, small scale sand waves that parallel the beach contours and obliterate the large, extensive rhomboid marks that are found on the otherwise flat beach face.

3.3 Scour/Burial Mechanisms and Mine Migration

Mine burial by scour and roll are shape dependent processes that vary in direct proportion to the degree of scour. The degree of scour is determined by the intensity of hydrodynamic forcing, the size and weight of the mine, and bed composition and slope. Mine migration for cylindrical mines proceeds by a series of scour and roll events (Figures 2-10 and 3-7a), whereby the mine successively scours a depression and then rolls into that depression (Inman and Jenkins, 1996). Flat bottom mines (e.g., MANTA, ROCKAN, etc.) bury by scour and slip sequences (Figure 3-7b) involving episodic shear failures of the sediment under the mine (Inman and Jenkins, 1997). During shear failure, the mine is in a state of sliding friction with the bed, and is moved by gravity and hydrodynamic forces.

Both of these mechanisms (scour and roll, and scour and slip) involve movement of the mine during the burial sequence. Over erosion-resistant beds, waves and currents may cause mines to migrate large distances before scour and burial arrests further mine migration. During lower energy summer condition, sand moves onshore from the shorerise, shifting the bottom profile shoreward, exposing the mines and inducing migration (e.g., Figure 4-4). On muddy seabeds during storms, both the mine and seabed may move as a unit (Figure 3-7c).

Mine migration is governed by Newton's 2nd law and the controlling relations are formulated by balancing the forces due to mine acceleration against the hydrodynamic and gravitational forces acting on it. When the moments hydrodynamic forces on the bed exceed the gravitational restoring moment on the mine (Figure 3-8) incipient mine migration results by scour and roll or scour and slip mechanisms. The threshold criteria for mine migration by cohesive bed failure (Figure 3-7c) is given by formulations for erosional stress (Aijaz and Jenkins, 1994).



Figure 3-1. Circular scour depression caused by waves and currents around pier pile.
[Inman negative, 77.102-2]



Figure 3-2. Wind formed crescentic scour pattern around a rock (~30 cm diameter) on the beach berm, Coronado, CA. Wind blows from left to right. [Inman photograph]

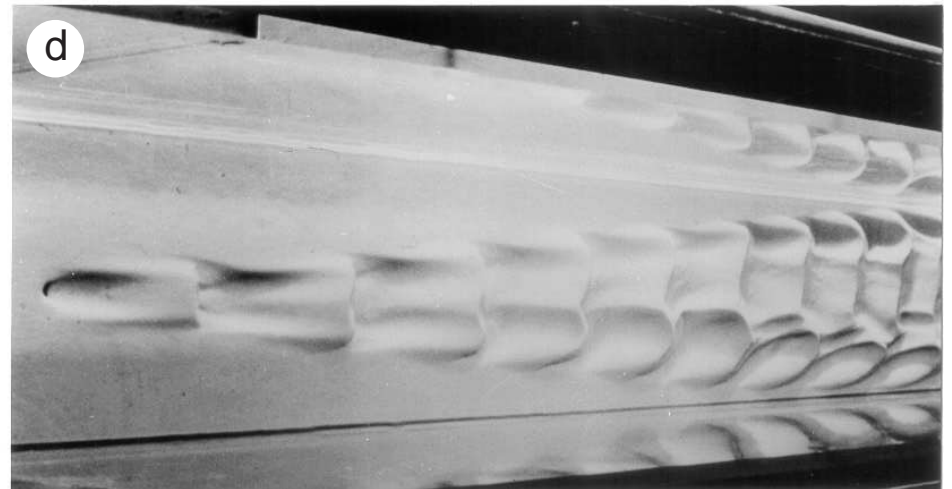
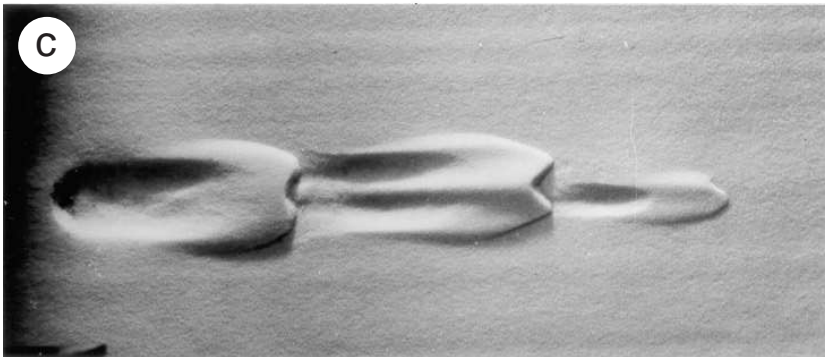
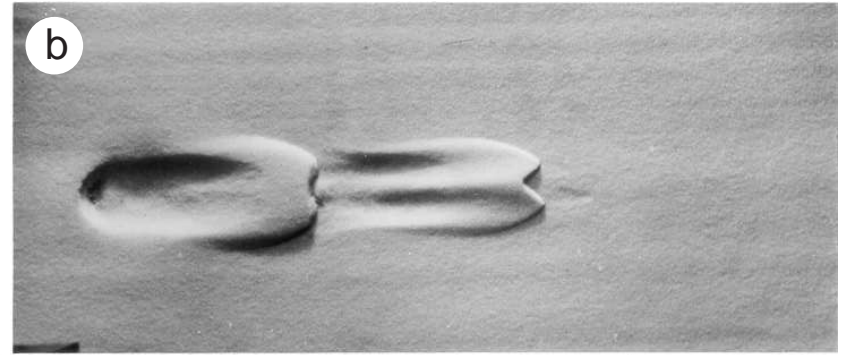
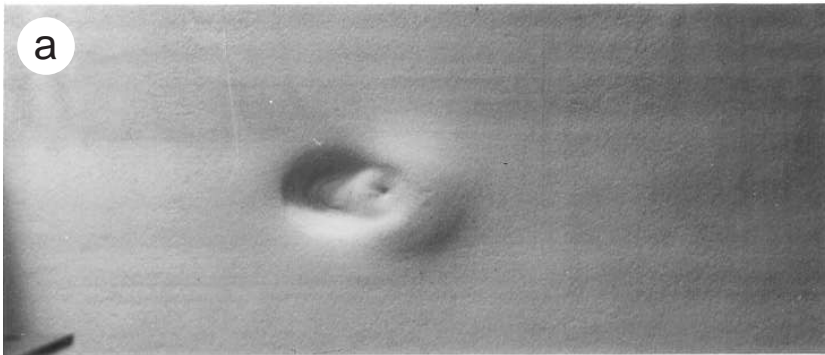

Figure 3-3. Progressive downstream propagation and lateral widening of a single perturbation (a) on a fine sand bed. Flume is 17 cm wide (sidewalls panel d) and bottom stress is near the threshold of grain motion. [photographs from Southard and Dingler, 1971]

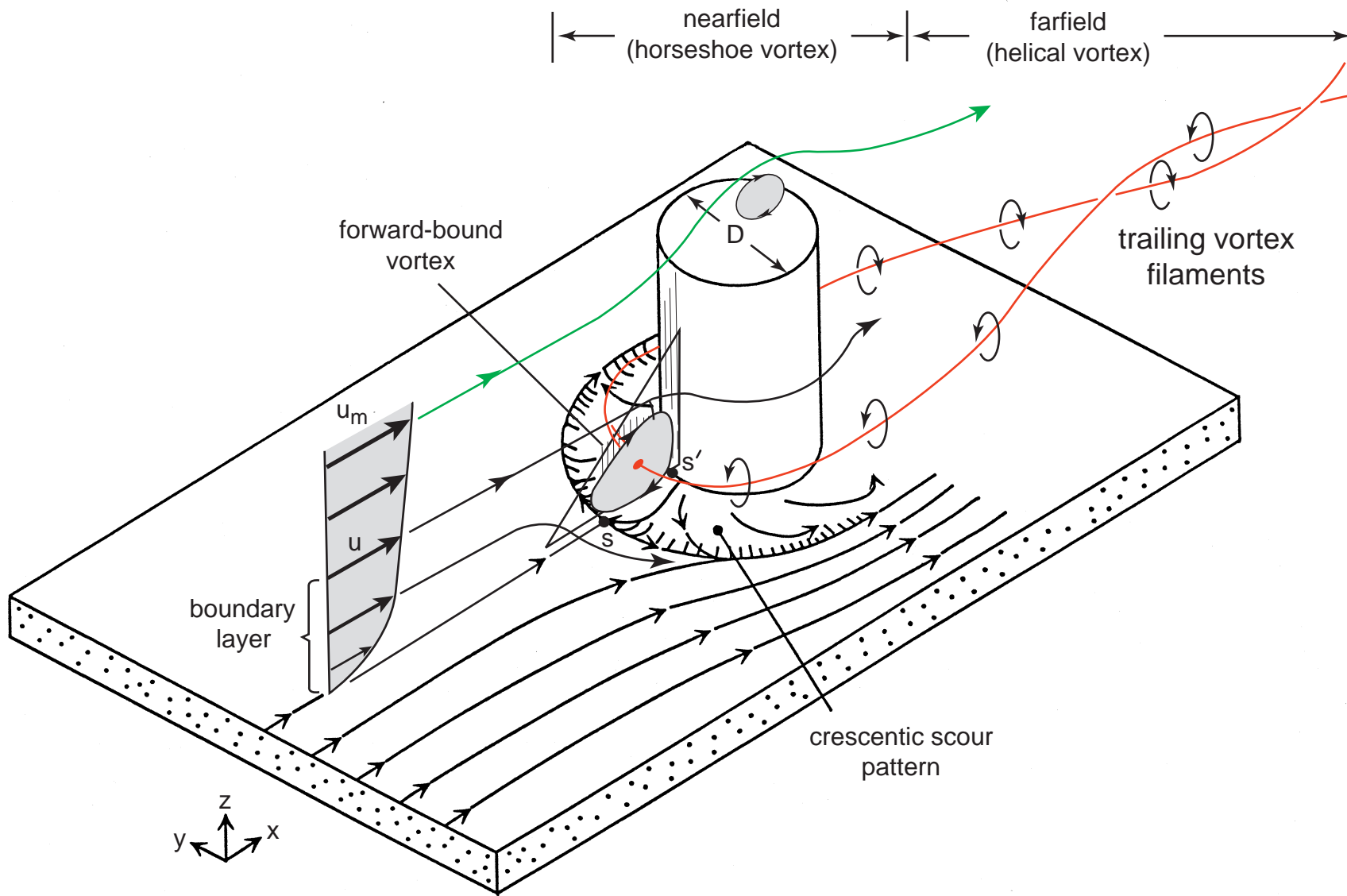

Figure 3-4. Definition sketch of fluid motion and scour features around an upright cylinder extending through the surface of a sediment bed under unidirectional flow [after Schlichting, 1979; Allen, 1984]; compare with Figure 3-1. [from Inman and Jenkins, in press 2002a]

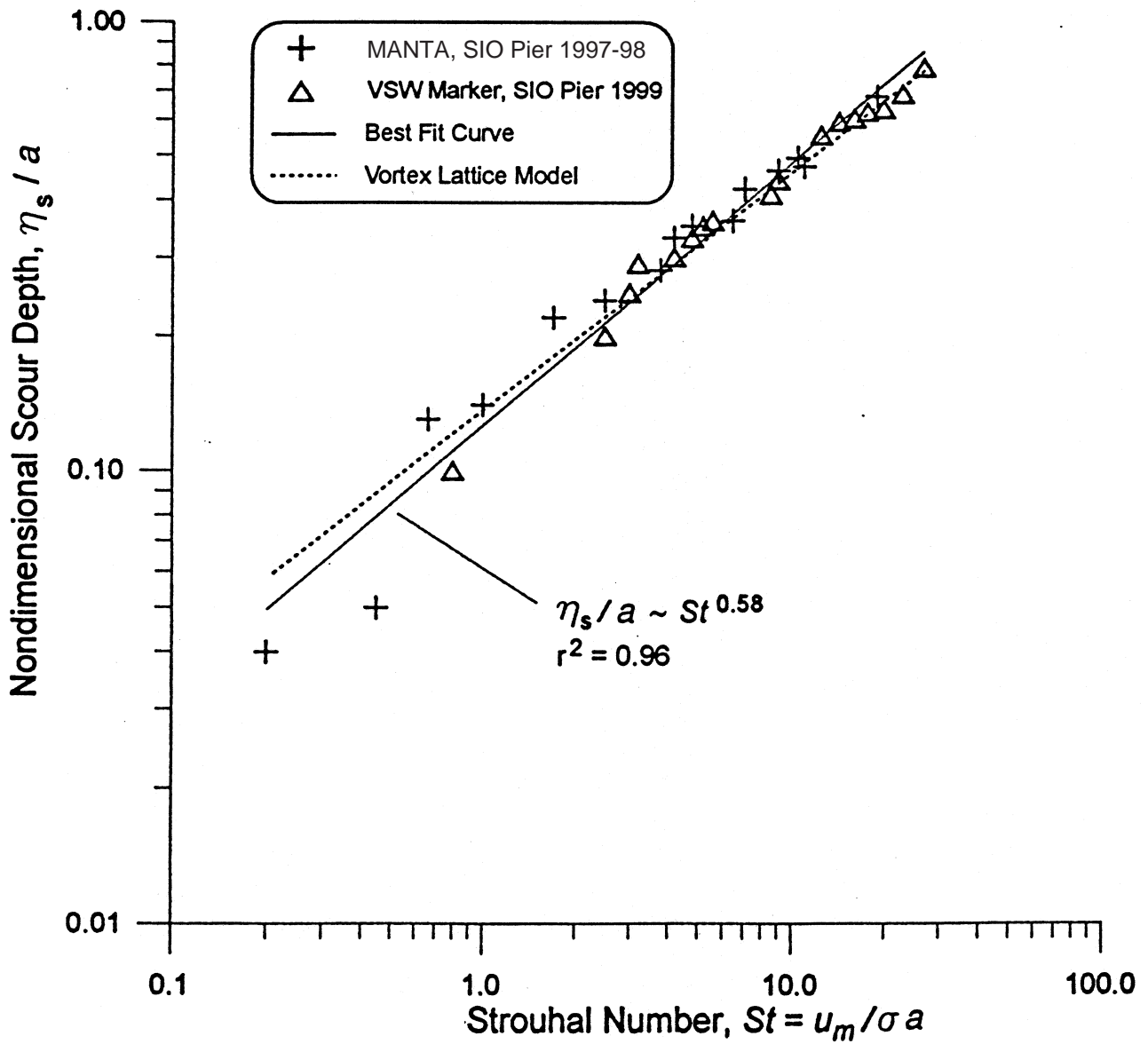
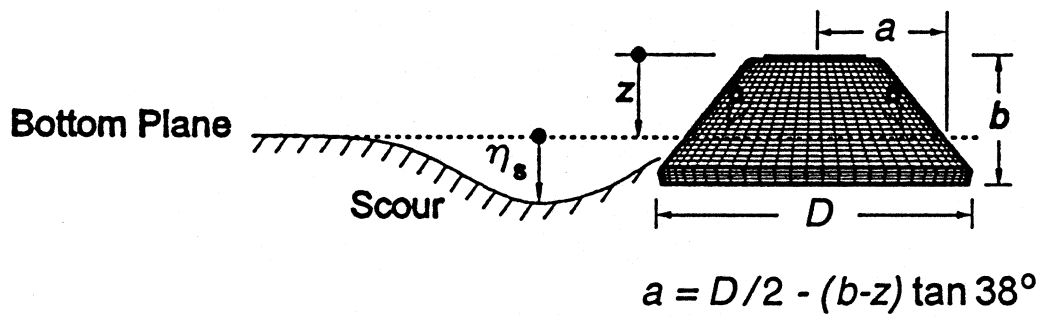

Figure 3-5. Dependence of scour depth on Strouhal number St for a MANTA mine.

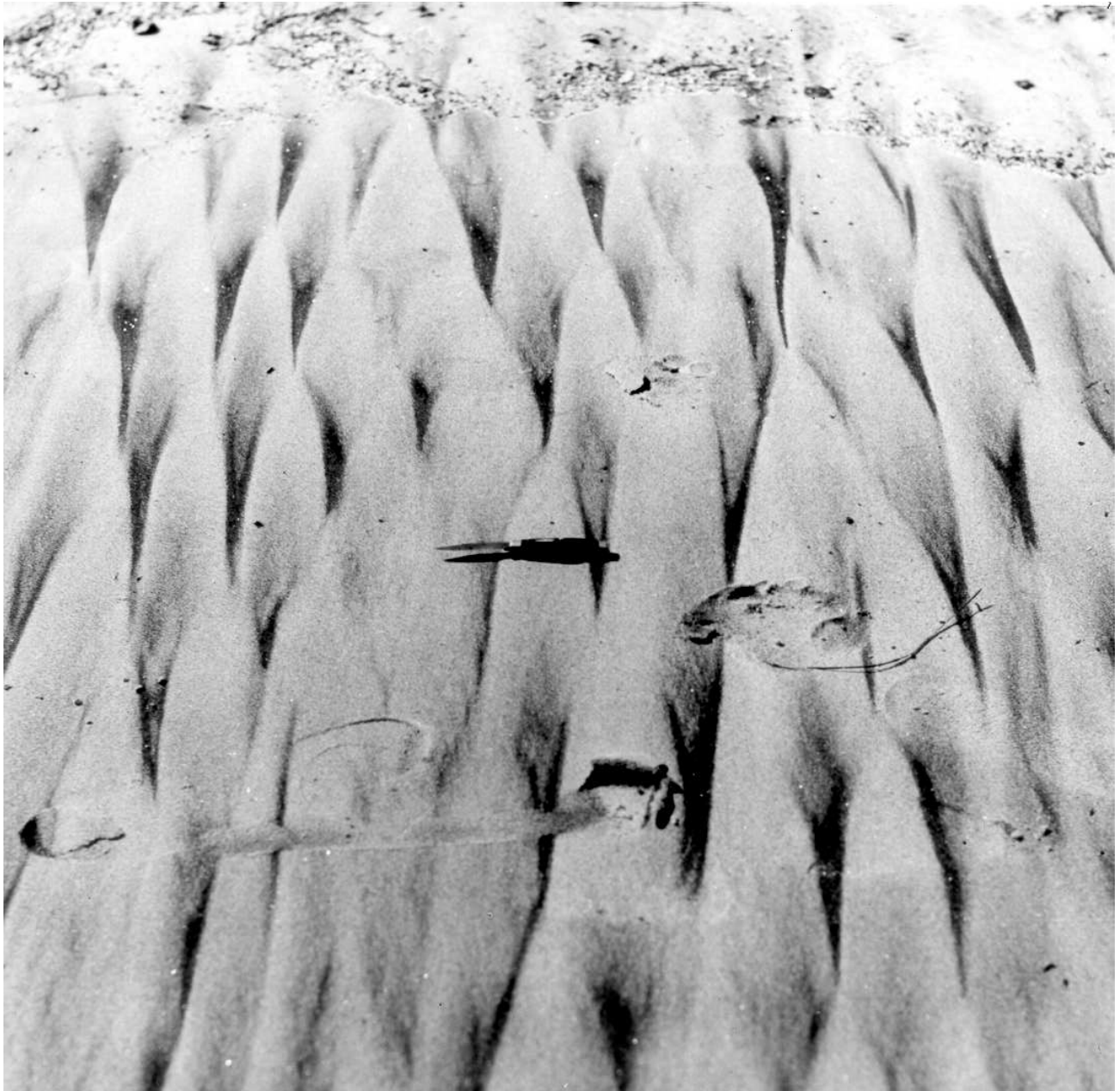

Figure 3-6. Rhomboid ripple marks on beach face at La Jolla, CA. Diamond pattern associated with flow divergence around antennae of a field of sand crabs (*Emerita analoga*). Photo looking seaward, knife (including blade) 12 cm, swash mark at top. [Inman photograph]

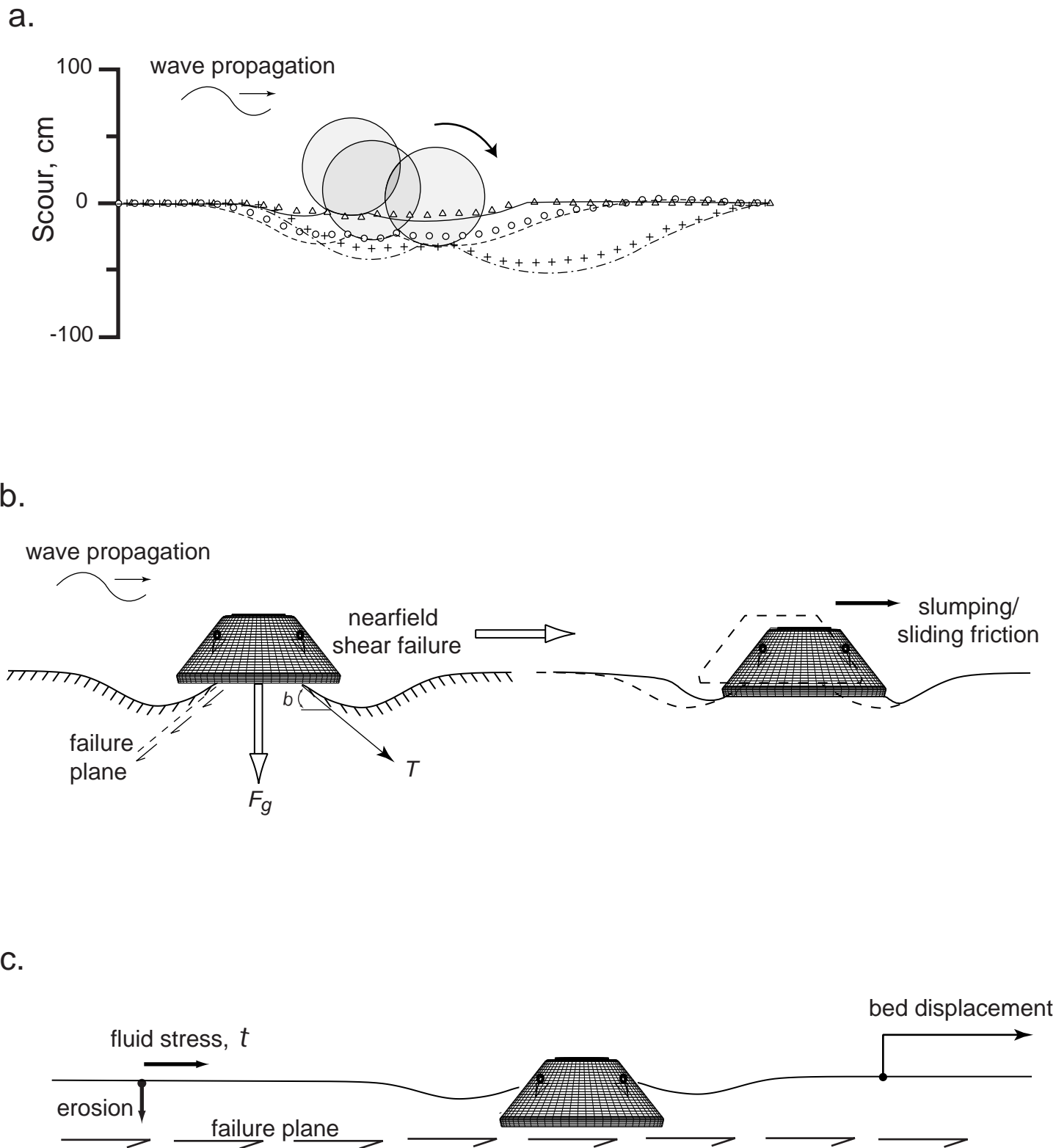
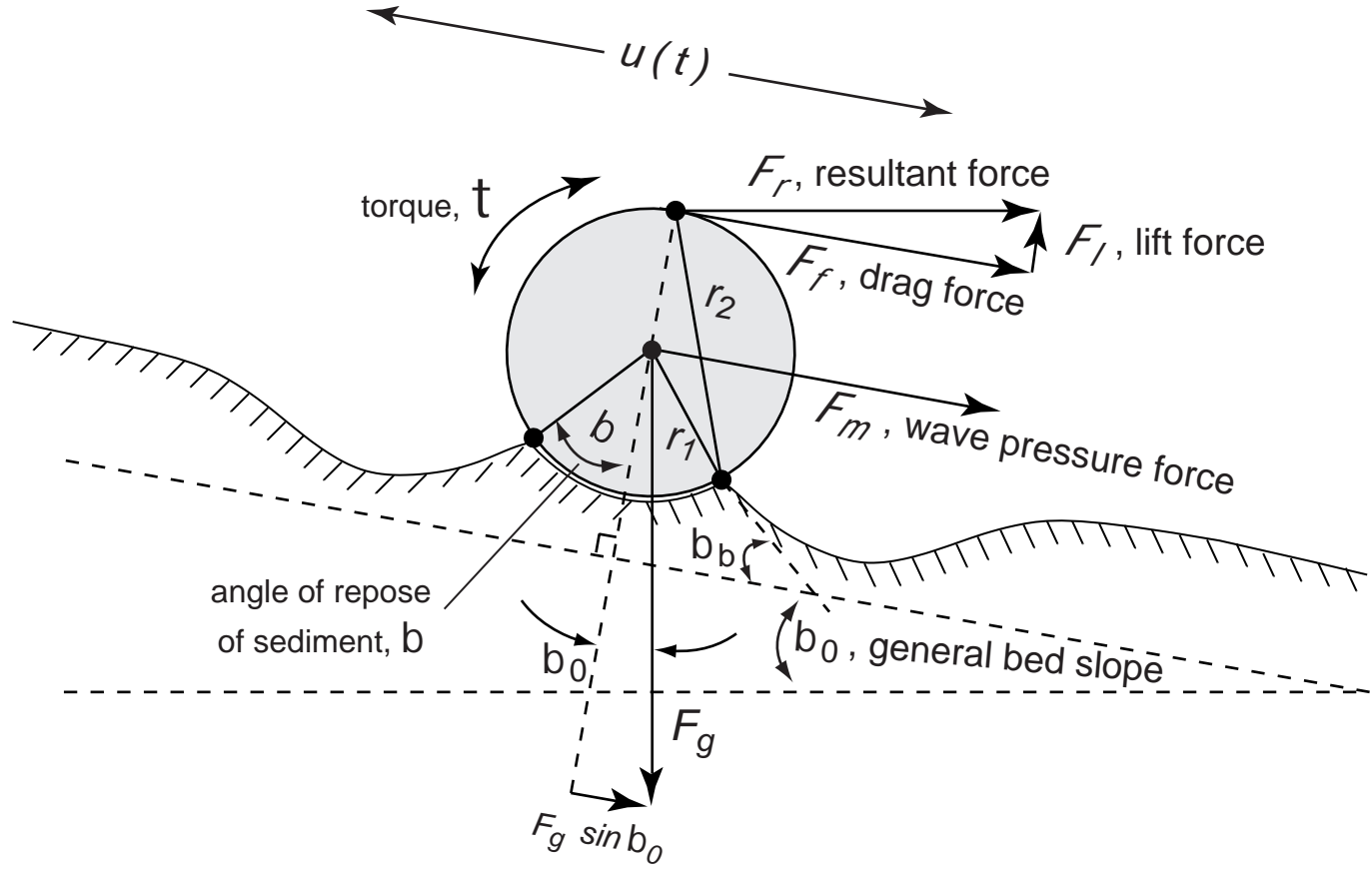

Figure 3-7. Burial and migration mechanisms: a) nearfield scour and roll, b) nearfield scour and slip, c) cohesive bed failure.



Threshold of migration criteria: $\sum \text{moments} = 0$

$$\vec{F}_g \times \vec{r}_1 = \vec{F}_m \times \vec{r}_1 + \vec{F}_r \times \vec{r}_2 + \vec{t}$$

Figure 3-8. Criteria for incipient mine migration. Mine moves when the sum of moments due to hydrodynamic forces (right side of equation) exceed the moment due to gravity (left side of equation).

4. PREDICTION OF MINE BURIAL: A MULTI-FACETED PROBLEM

The details of mine detection in coastal waters and their eventual neutralization are varied, complex, and the subject of special procedures and training programs conducted at naval installations, known generally as “mine countermeasures” and counter-mine warfare. The most up-to-date mine countermeasure procedures are described in naval warfare publications (mostly classified). However a fairly extensive literature exists on past experiences in previous wars (e.g., Duncan, 1962; Elliott, 1979; Friedman, 1982; Gregory, 1988; Hartmann, 1991; Melia, 1991; Levie, 1992; Morison, 1995).

Operationally, mine countermeasure units hunt (detect) when they can and sweep when they must. Mine sweeping by ship and cable have been effective for moored mines in sufficient water depth for sweepers to maneuver. Sweeping for bottom mines that remain on the surface of the bottom is more difficult, but influence mines on the surface of the bottom can often be neutralized with acoustic and magnetic sweeps. However mines in water depth less than about 8 m and mines that have buried into the surface sediment or have partially buried become unique exceptions to all traditional detection and sweeping techniques, as do all contact bottom mines, the most common anti-invasion mine. Under these circumstances, it is essential that there be acceptable means of predicting mine burial, given the essential information of time of deployment, size and shape of the mine, and the environmental characteristics of the lay site. Even though these essential factors may not be known with accuracy, it is important to have the capacity to make reasonable estimates of mine burial for a coastal environment, given likely times of deployment and types of mine.

A combined, two-step procedure is employed for predicting burial of bottom mines, *electronic process modeling* supplemented by the *expert systems modeling* (ESM). Properly programmed and coded electronic process modeling produces good, reliable estimates of mine scour and burial when the critical input parameters are accurately known. However, there is always some degree of uncertainty associated with the reliability of our knowledge of some input parameters. For example, are the mines actually truncated cones (e.g., Italian MANTA) as modeled, or are they or some of them, cylindrical like the Russian MDM-2 (Figure 1-2) Their different shapes make their scour and burial characteristics very different. Or was the bottom sediment fine sand as modeled or actually mud or gravel? Again

the scour/burial characteristics would be different, and so on. The expert systems model (ESM) is employed when these uncertainties in input are too large for process modeling.

4.1 Expert Systems Modeling (ESM)

The expert systems model (ESM) is a decision making procedure used where the available knowledge consists of a number of incomplete data sets of uncertain bounds and relative importance. ESM may be electronic with computer code or in hard copy form such as a manual with tables and figures. These models have been used for at least a decade to control and direct air traffic and shipping around weather systems and to provide the most efficient mixes in refineries and factories (e.g., Nemhouser et al., eds., 1989; Kirman et al., 1991; Klein et al., 1991). The data sets are formed into a set of rules of the if/then (fuzzy logic) type. The rules are assembled into a logical sequence referred to as a belief network or network topology, that represent causal relationships between key variables (e.g., Bayesian networks using wave height, sediment size, bottom roughness and, time). Since the number of possible rules and topologies are large, an expert is required to decide on the most sensible formulation of rules and topology, i.e., the *best belief network* (e.g., Santos, 1996; Zhang, 1998). Expert systems are part of the field of artificial intelligence, and where electronic modeling is involved, are in the category of synoptic or experience-based (pattern), rather than the process (deterministic) models developed to predict the physical scour and burial of mines.

All approaches to modeling sedimentary processes and mine behavior utilize essentially the same scientific and engineering input. The interaction between expert systems modeling (ESM) and process modeling is illustrated schematically by the hierarchy in the pyramid of interactive inputs for mine burial prediction shown in Figure 4-1. The types of information required (inputs) for modeling mine burial form the five vertices of the pyramid. In the beginning (top of the pyramid, $t = 0$), little information is available about the mines and mine lay area of concern, but more and more information becomes available as time increases, represented by the area of the expanding base of the pyramid with increasing time. An ESM prediction, because of its probabilistic nature, can be made at any time, although early prediction may be inaccurate (Figure 4-1a). In contrast, process modeling requires that there be specific input in all five categories of information (1-5 at base of the pyramid) before the model can make a prediction (Figure 4-1b). However, if the input information is accurately known, then the process model predictions can

be highly reliable. Since there is always some degree of assumption and uncertainty regarding the inputs to any model, a combination of processes modeling and expert systems modeling provides the best overall estimates of mine scour and burial (Figure 4-1c). This arrangement uses the process model to give solutions for possible combinations of inputs while the ESM is used to sort them for the most probable combination. The five inputs shown in Figure 4-1 will be discussed in greater detail under process modeling (§4.2) and a review of the role of coastal types and their associated littoral cells is presented in Appendix A.

The deterministic process-based model is an automated system that rapidly produces burial predictions for all desired time intervals and initial burial states, given a specific set of inputs. Each selection of variables becomes a unique problem that must be solved individually. In the ESM, all possible combinations of variables are solved as a single problem based on assumed probability of occurrence for the variables. Thus the ESM organizes the admissible solutions obtained by a process model. Since ESM does not start with a well posed problem, there are usually a number of admissible solutions to which it can assign a probability of occurrence. Thus, if all the needed information is available, a process model should be used because it would provide a definitive solution of highest accuracy. When the information is incomplete, the ESM considers all possible solutions and provides the most likely answer, but with less confidence.

An example of the type information that process models can provide as input to the ESM is illustrated in Figure 4-2. The VORTEX model (described in §4.2) was coded and calibrated for the burial state of a MANTA mine subject to wave action during a five year period (Figure 4-2a, 1995-2000). The model prediction as compared to field measurements of burial is shown in (b). From this information, the probability of the mine burial state as a function of wave height for the entire period of record (1980-2000) is provided as a useful input for an ESM prediction (c). Figure 4-2c predicts burial that would occur in a 24 hour period when the mine is initially in a state of no burial.

4.2 Process Modeling of Mine Scour and Burial

Computer simulation models are becoming increasingly popular because they are reasonably inexpensive to develop and permit easy testing of the relative importance of variables. There are two general types: synoptic (pattern) models and process (deterministic) models. Synoptic models look for trends and patterns

within vast amounts of data and then associate these patterns with future trends to make forecasts. Expert systems models are synoptic. Process models employ the mechanics of the processes (e.g., equations of motion, continuity, etc.) to compute an end product such as the scour around a mine caused by wave action. Most long term climate models are synoptic, while short term meteorological models are of the process type (Inman and Masters, 1994).

In using models, it is to be remembered that they are always simplifications of the real world. Models treat the first order (dominant) processes and neglect the higher order (weaker) processes. So we do not model the real world but rather what appear to be the most obvious parts of it. This means that omission of the less obvious parts, which are often nonlinear, may bias the simulation in serious ways, leading to closures that do not exist in nature. Models are extremely useful in testing ideas, but it is not possible to model the real world in detail. As shown by Oreskes et al., 1994, this is because natural systems are never closed and, given the same input, are often unique, whereas models are not. Further, following the Heisenberg uncertainty principle, there is a natural limit on precision so that model prediction cannot be obtained with certainty at the finest scales.

Architecture of the VORTEX Model

During the past six years a process model for the scour and burial of mines has been developed and evaluated at the Scripps Institution of Oceanography. The model is known as the Vortex Lattice Mine Scour and Burial (VORTEX) Model (Inman and Jenkins, 1996; Jenkins and Inman, 2002). The model attempts to duplicate in code the first order processes that cause mine burial. Therefore it is necessary to understand where the processes are applied, and what forces are driving them. Consequently process models are built around a number of components called *primitive models* that specify a basic relationship between *forces* that drive *processes* that act on *boundaries* and produce *responses*. Because there is usually more than one process causing a given response and that process may be driven by a number of forces that act in many places, the primitive models are often bundled together in operative units called *modules*. There are separate modules for the processes, forcing functions, boundary conditions, and response. The primitive models and modules are linked together to create the model *architecture*.

The modules in the architecture for the VORTEX model shown in Figure 4-3 are represented by shaded boxes bounded by dashed lines, and the primitive models

are the numbered boxes bounded by solid lines that are grouped within the larger shaded module boxes. The arrows connecting the boxes represent the flow of data between the primitive models and modules. Arrows pointing into a box are inputs, and arrows leaving a box are outputs. Note that the output of some primitive models and modules provide input for others thus allowing one model to drive the other so that they function in tandem as *coupled models*. Figure 4-3 is built from a number of primitive models that are grouped together in modules that define the basic elements of a process model, i.e., processes with their forcing functions, boundary conditions, and responses. The ordering of these primitive models and modules in the architecture is built around a logical sequence governed by the hierarchy of interactive inputs listed in Figure 4-1.

Burial Processes: Burial processes are divided into two general categories: nearfield and farfield (Figure 4-4). These operate on significantly different length and time scales. Nearfield burial processes occur over length scales the order of the mine dimensions and on time scales of a few seconds, primarily governed by the scour mechanics described in §3. In contrast, farfield processes involve changes in the elevation of the seabed with cross-shore distances of hundreds of meters that may extend along the coast for kilometers. Farfield time scales are typically seasonal with longer periods due to variations in climate.

Farfield: Farfield burial mechanics are associated with large scale processes including changes in beach profile, deposition from rivers (Figure 4-5), sediment loss by turbidity currents, and bottom modification by ice push. Because the farfield processes determine the elevation and slope of the seabed on which the nearfield processes operate, the farfield exerts a controlling influence on the nearfield, and these processes are considered at the beginning of the model (Figure 4-3).

Farfield processes are controlled by the balance between the amount of sediment entering the farfield and the amount leaving. This balance, known as the sediment budget, requires the identification of sediment sources and sinks, which will vary with the type of coastline. Some basic types of coastlines have been identified, and the sediment sources and sinks are listed in Table 4-1 (column 3 and 4) and discussed in greater detail in Appendix A. The Geomorphic Coastal Classification module in VORTEX (Figure 4-3, ①) selects the relative scaling and assigns the sediment sources and sinks to which a particular burial site belongs. The

classification includes three general tectonic types of coasts with their morphologic equivalents, and two types associated with latitudinal extremes: 1) collision coasts with narrow shelves and steep coastal topography resulting from collisions between two or more tectonic plates (Figure A-1a); 2) trailing edge coasts that are on the stable, passive margins of continents with broad shelves and low inland relief (Figure A-1b); 3) marginal sea coasts that are semi-enclosed by island arcs and thereby fetch limited (Figure A-3); 4) cryogenic coasts that are affected by ice processes (Figure A-4); and, 5) biogenic coasts that are formed by fringing coral reefs (Figure A-5) or mangroves, etc. Schematic examples of the leading order morphology of these coastal types is listed in the first column of Table 4-1 with characteristics and representative sites (indicated in parentheses) given in column two.

Although the relative importance of transport processes vary among coastal type, two processes are always important to mine burial. These are seasonal changes in the beach profile and fluxes of sediment into and out of the mine lay area by accretion/erosion waves (Figure 4-6). Accretion and erosion waves in some form are common along all coastlines subject to the littoral drift of sediment (Inman, 1987; Inman and Jenkins, in press 2002b). The coarse sediment from a river flood will initially cause an accretionary bulge in the form of a sand delta (Figure 4-6, t_1). The net littoral drift will perturb this deltaic accretion through a series of spit extensions (t_2). Over time, cumulative spit extensions will progressively displace the accretionary bulge in the downdrift direction while local wave refraction will cause erosion downdrift of the bulge (t_3). As the accretion and erosion migrate downdrift in unison, this shoreline disturbance takes a wave-like form. The accretion/erosion wave will in turn perturb the equilibrium position of the beach profiles throughout its path of migration causing sequential exposure followed by burial of mines along the way.

A related problem of mine burial/exposure occurs when the littoral drift impinges on tidal inlets causing them to migrate (Figure 4-7). Tidal inlets are often used for harbor entrances. Inlet migration proceeds as an accretion of the updrift bank in response to positive fluxes of sediment delivered by the net littoral drift (Figure 4-7 ① and ②), while the downdrift bank of the inlet erodes due to a reduction of drift across the inlet by sediment deposited on the islands and bars in the lagoon ②. The inlet banks and channel form an accretion/erosion sequence that travels downcoast by spit extension on the updrift side and spit erosion on the

downdrift side. Consequently mines will be either buried or exposed depending on the relation of the mine lay patterns to the migrating inlet channels and tidal bar ③.

Seasonal variations in wave climate cause changes in beach profiles (Inman et al., 1993). For example, in Figure 4-8a, a mine placed in the VSW zone in summer during low waves (solid line) may become buried by high winter waves that erode the inner portion of the beach depositing the eroded material on the outer shorerise as a sand bar (dashed line). Conversely, a mine that buries by scour during winter may be re-exposed when summer waves move sand onshore. Seasonal burial and exposure processes are treated by the primitive farfield model (Figure 4-3, (10)), as shown by the burial and exposure cycles of a MANTA mine (Figure 4-8).

Nearfield: Nearfield burial processes are related to the scour induced by the presence of the mine as described in §3. In the VORTEX model these processes are calculated by the coupled models and modules below the green line (Figure 4-3). The mine and adjacent seabed is subdivided into a set of panels (*lattice*) as shown in Figure 4-9. The vortex field induced by the mine is constructed from an assemblage of horseshoe vortices, with a horseshoe vortex similar to that shown in Figure 3-4 prescribed for each panel. This computational technique is known as the *vortex lattice method* and has been widely used in aerodynamics and naval architecture (e.g., McCormick, 1979). The strength of the vortices, Γ_i , is derived from the pressure change over each panel associated with the local wave and current velocity. The release of trailing vortex filaments from each panel causes scour of the neighboring seabed. When viewed in any cross-wake plane each pair of filaments induces a flow across the seabed that results in scour proportional to the cube of the vortex strength, Γ_i , and inversely proportional to the cube of the sediment grain size. This sensitivity of scour to grain size selectively removes the finer grained fraction of the bed material and leaves behind the coarser grained fraction in the scour depression (e.g., Figure 2-6). The coarse material that remains in the scour hole armors the bed against further scour thereby slowing the rate of scour burial.

Scour burial is a shape dependent process that varies with the intensity of hydrodynamic forcing and with bed composition and slope. For cylindrical mines on a fine sand bottom, the burial mechanism proceeds by a series of scour and roll events (Figure 2-10 and 4-4a) whereby the mine successively scours a depression

and then rolls into that depression (Inman and Jenkins, 1996). In contrast, a flat bottom mine (e.g., MANTA, ROCKAN, etc.) buries by scour and slip sequences involving episodic shear failures (avalanches) of the slopes of the scoured depression (Jenkins and Inman, 2002). During these shear failures, the mine is in a state of sliding friction with the bed and is easily moved by the hydrodynamic forces of waves and currents. Both of these mechanisms (scour and roll or scour and slip) may be arrested by large scale changes in the bed elevation due to either seasonal profile changes or influx of material by accretion/erosion waves.

Forcing Functions: The farfield and nearfield burial processes are driven by a set of forcing functions that are common to all coastal types, but like processes, vary in relative importance among coastal types. The Geomorphic Coastal Classification System (Figure 4-3, ①) is used to assign dominant forcing functions for the model based on the characteristics detailed in Appendix A. Forcing for the VORTEX model includes waves ②, coastal and tidal currents ③, and precipitation that drives river sediment flux ④. All calculations are time stepped, so that calculations of mine burial/exposure require elapsed time since initial impact burial. Ideally, bottom velocity measurements of waves and currents give the most accurate burial predictions, but such data is not usually available. In the absence of direct measurements, the model generates the bottom velocity from predictions of wave height, period, and direction generated by forecast models of the Fleet Numerical Meteorological and Oceanographic Center (FNMOC) or from seasonal estimates derived from the coastal classification system in Table A-1. For tidally dominated environments, the model requires harmonic tidal constituents to compute tidal currents. Burial from river sediment flux requires river flow rates and sediment rating curves. The sediment rating curve can be user specified or pre-configured from selection of coastal type.

Boundary Conditions: The farfield defines the outer boundaries of the geographic area that the model considers when making predictions. The farfield is subdivided into many smaller, locally-uniform areas (usually small rectangles) referred to as control cells (Figure 4-6). Collectively these control cells make up the *farfield grid*. The model computations are performed directly on each control cell, and the solutions of all the control cells are assembled to give the complete

solution for the processes in the farfield. This subdivision of the model's computational space according to process is referred to as *nested gridding*.

The outer boundaries of the farfield are determined by a littoral cell. A littoral cell is a geomorphic compartment that includes the sediment sources, transport paths, and sinks that can potentially accrete or erode the seabed around a mine field. Everything above the orange line in Figure 4-3 treats processes and forces bounded by the littoral cell. The cell boundaries delineate the geographical area wherein the budget of sediment is balanced, providing the framework for the quantitative analysis of farfield burial processes. The farfield grid must be tailored to fit the littoral cell boundaries and to include all important sediment sources such as rivers, relict offshore shoals, bluffs, and coastal dunes. Sediment sinks include submarine canyons, lagoons, barrier rollover and, wind-blown losses. The transport pathways between these sources and sinks vary in a systematic manner according to coastal type as described by the coastal classification system in Appendix A.

The characteristic dimensions and sedimentary properties of the littoral cell also vary systematically according to coastal type, and these relationships are used to specify the control cell requirements and scale factors for the farfield. For example, the collision (Figure A-1) and coral reef coasts (Figure A-5) have relatively steep bottom gradients with small cross-shore dimensions (Table 4-1, column 6) and a high degree of longshore compartmentalization by coastal headlands. This leads to fairly compact farfield grid domains with grid resolution set for long fetch, high energy waves. This in turn dictates relatively deep closure depths (depth of vanishing net on-offshore transport, column 5). On the other hand, marginal seas are fetch limited and the resulting short period waves dictate small grid scales and shallow closure depths. However the longshore dimensions of littoral cells in marginal seas may be quite extensive (e.g., Figure A-3), which in combination with fine scale grid resolution requires grid domains with large numbers of points (sometimes presenting data storage and model run time problems). The most extensive modeling challenge due to large grids, however, is encountered for the trailing-edge coasts (e.g., Figure A-2) where the low relief shelf and deep closure depth leads to very large cross-shore dimensions in the farfield domain. In addition the trailing-edge littoral cells typically extend 100 km or more alongshore, producing farfield grid arrays of about 10^8 points; where the

grid array size is on the order of the littoral cell area divided by the square of the half wavelength of the characteristic wave.

Response: Farfield burial of a MANTA mine subject to seasonal beach profile changes is shown in Figure 4-8b. The crosses are from diver observations and the solid lines are model predictions. Mines placed at about the mid range of the VSW zone are found to bury beneath as much as 20 cm of sand when the beach erodes and the sand is transported offshore during high waves. The mine becomes re-exposed during low waves when the sand is transported onshore to the beach. Only farfield changes in the bottom elevation can cause further deposition of the mine once it is buried. This is because no scour is possible once the mine is buried. Nearfield burial is therefore regulated by the farfield, because the farfield determines the change in sand level.

4.3 Mine Burial Predictions

Process models are particularly useful in identifying trends or cause and effect relationships that can form a basis for predictive rules of thumb. Repeated trial runs with these models making sequential changes in input variables, show the relation between forcing and mine burial. The VORTEX model is especially powerful in this regard because it provides a complete 3-dimensional image of the nearfield burial as illustrated in Figure 4-10 through 4-12. When model results are compared with observations described in §2, a number of generalities are found that can be formulated into rules of thumb for mine burial.

Some Rules of Thumb For Mine Burial

1. Cylindrical mines will bury by a scour and roll sequence, during which the axis of the cylinder will align itself parallel to wave crests (Figure 4-10a).
2. The cylindrical mine may move a number of mine diameters in the direction of wave propagation during the burial sequence (Figures 2-10 and 4-4a).
3. Scour holes formed by cylindrical mines are deepest at the ends of the mine. During burial, cylindrical mines are buried more in the middle and become exposed at the ends (Figure 4-10).
4. Three-dimensional shapes (cones and hemispheres) bury more slowly than two-dimensional (cylindrical) shapes (Figure 4-10).

5. Small mines scour and bury deeper relative to their diameters than large mines, while absolute burial as measured from sediment surface to mine keel is greater for large mines (Table 2-1).

6. Scour burial rates decrease as burial depth increases (Figure 4-11). This is because a partially buried mine presents a smaller silhouette to the flow.

7. Flat bottom mines (cones and hemispheres) will move less than 1 diameter during a burial sequence (Figure 4-10, 4-11). However, hemi-oblate spheroids may flip over and move farther (cf. Figure 2-12 and 13).

8. Burial rates due to scour by wave action are faster in the shallow water portion of the VSW zone.

9. Burial rates due to current action are usually faster in the offshore portion of the VSW zone (about 10-12 m depth) where coastal currents are more concentrated. However, longshore and rip currents may cause rapid burial and/or re-exposure in and near the surf zone (high tide to 3 m depth).

10. Impact burial is not a significant burial process in sandy environments (collision coasts, trailing edge coasts removed from river mouths, coral reef coasts). Impact burial is typically less than 10% in these environments.

11. Impact burial is the dominant burial process in muddy environments (deltaic marginal sea coasts and in estuaries and near river mouths of all coasts). Impact burial is typically 75% to more than 100% in these environments.

The nearfield burial response computed by the VORTEX model can also be used to assess other features important to mine detection and neutralization. Figure 4-12 gives the scour pattern for a MANTA mine on a fine sand bottom in a 40 cm/sec current. The simulation reveals bedforms unique to the presence of a mine, such as *stagnation crescents* and *shadow ridge pairs*. Such bedforms undoubtedly have unique acoustic scattering properties important to mine hunting that are different from the indigenous bed roughness. Also, the VORTEX model solves for the interactive effects of multiple and/or different shaped objects in close proximity. For example, placement of the VSW marker on the down-wave side of a MANTA mine was found to increase stationkeeping time (i.e., time that a

neutralization charge remains within an effective kill radius of a mine). This is due to the scour shadow effect provided by the presence of the mine (Figure 4-10c). These examples illustrate one of the great advantages of a process model; it has the ability to discover cause and effect relationships between process and response that are not easily or frequently observed.

Typical Rates of Mine Burial

In general, burial rates of mines in the VSW zone will vary according to the characteristics that coastal type places on the key variables that affect burial. These variables were identified in Tables 4-1 and elaborated in Table A-1. The variables include the sediment grain size, bed roughness due to bedform, wave climate (energy flux and characteristic period), closure depth, and littoral cell dimensions. The mid-range for each of these variables was selected from Tables 4-1 and A-1 according to coastal type and used to initialize the free parameters of the VORTEX model. The variation of model prediction with parametric assignment is referred to as *sensitivity analysis*.

The sensitivity analyses were done for 7 m depth (the mid-depth range of the VSW zone) using a cylindrical mine (Figure 4-13) and a truncated conical mine (Figure 4-14). Both cases were run for a 1 month burial period. These two mine examples show the general difference in scour characteristics between a 2-dimensional shape (cylinder) and a 3-dimensional shape (truncated cone) of equivalent weight. Comparison of Figures 4-13 and 4-14 shows that the cylindrical shape buries faster than the truncated cone for all coastal types with the possible exception of the deltaic tideless marginal sea. In that case, burial is total for both shapes and is dominated by impact mechanics.

In general, marginal sea environments have the slowest burial rates for local waves of moderate height (less than 1.5 meters) because the short fetches produce shorter, less intense waves. However, the narrow-shelf marginal sea with its finer silty sands and shallow closure depth is prone to the development of large bedforms that may accelerate burial during high waves. Since high waves are generally rare along these marginal seas, the curves in Figure 4-13 and 4-14 do not extend beyond 2 m heights. High energy collision coasts have the highest burial rates following impact. This is due to the well sorted fine sand typical for these coasts. Also, the narrow shelf and long wave periods of these high energy coasts yield maximum onshore orbital velocities to induce scour. The burial rates along trailing edge

coasts are similar to those on collision coasts, but the tendency for coarser sands along some of the former coasts lead to decreased rates. Similarly, the coarse carbonate sediments of the biogenic coasts also have lower burial rates than the collision coast in spite of similar wave climate.

A summary of burial rates over time periods ranging from days to several months is given in Table 4-2 for cylinder and truncated cone mine shapes. Both shapes show that burial is progressive over time but tends to decrease in rate with time as the mine silhouette decreases. The only exception to this rule of thumb occurs in the deltaic marginal sea where nearly all the burial occurs during impact. The results in Table 4-2 generalize the farfield burial based on long term mean values for forcing and littoral cell scales. Burial rates can be quite different if extreme events such as storms, river floods, landslides, or tsunamis occur.

Table 4-1. Coastal classification system with synthesized model input parameters, cf Table A-1.
[from Jenkins and Inman, 2002]



Coastal Type	Boundary Conditions					Model Parameters		
	Morphology (Example)	Sediment Source	Sediment Sink	Closure Depth	Littoral Cell Dimensions	Grid Cell	Grain Size	Bed Roughness, h_0
 <p>A. Collision</p>	Narrow-Shelf Mountainous Coastal Bluffs (California)	Rivers & Bluff Erosion	Submarine Canyons	15 - 18 m	Longshore: 50 km Cross Shore: 1 - 5 km	Farfield: 70 - 90 m Nearfield: 1 - 4 cm	Beach: 0.2 - 0.3 mm Shelf: 0.06 - 0.10 mm	0.5 - 3 cm
 <p>B. Trailing Edge</p>	Wide-Shelf Plains (Duck, NC)	Headlands & Shelves	Roll-Over Shoals Spit-Extension	10 - 13 m	Longshore: 100 km Cross Shore: 30 - 50 km	Farfield: 40 - 80 m Nearfield: 2 - 7 cm	Beach: 0.2 - 0.4 mm Shelf: 0.06 - 0.15 mm	0.8 - 5 cm
 <p>C. Marginal Sea</p>	a) Narrow-Shelf Mountainous (Korea) b) Wide-Shelf Plains (Corpus Christi) c) Deltaic tideless (Mississippi) d) Deltaic tidal (Bangladesh) Wide-Shelf	Rivers & Deltas	a) Canyons b) Beaches & Barriers c) Delta & Shelf d) Delta Islands, flats, canyons	Narrow shelf: 7 - 10 m Wide shelf: 4 - 7 m Delta: 3 m	Longshore: a) 5-10 km b) 100 km c) 5-200 km d) var Cross Shore: a) 1 - 5 km b) 50 km c) 20-80 km d) var	Farfield: 10 - 20 m Nearfield: 1 - 3 cm	Beach: 0.06 - 0.21 mm Shelf: 0.01 - 0.09 mm Delta: .005 - .05 mm	a-d) 0.1 - 1 cm d) sand waves
 <p>D. Arctic Form of Cryogenic</p>	Plains Permafrost Tundra & Pack Ice (Flaxman Barrier)	Rivers Ice-Push Thaw Erosion	Coast Retreat Spit-Extension & Ice Rafting	5 - 7 m for Waves 10 - 25 m for Stamuki Zone 0 - 60 m for Ice-gouge	Longshore: 50 - 100 km Cross Shore: 10 - 20 km	Farfield: 200 - 300 m Nearfield: 1 - 15 cm for Stamuki 10 - 30 cm	Beach: 0.1 - 0.13 mm Shelf: 0.01 - 0.03 mm	for Waves 1 - 10 cm for Stamuki 1 - 2 m
 <p>E. Coral Reef Form of Biogenic</p>	Coral Reef Island (Hawaii)	Carbonate Reef Material Volcanic Headlands	Pocket Beaches & Awa Channels to the Shelf	Reef Platform	Longshore: ~2 km Cross Shore: 0.5 km	Farfield: 100 - 150 m Nearfield: 1 - 20 cm	Beach: 0.2 - 0.4 mm Shelf: 0.03 - 0.1 mm	Reef Platform ~1 m Offshore 1 - 15 cm

Table 4-2. Rules of thumb for mine burial rates. ^a

Coastal Type	Morphology (Example)	Cylindrical Mines ^b (MARK 52)				Truncated Cones ^b (MANTA)			
		1 day	7 day	30 day	90 day	1 day	7 day	30 day	90 day
1. Collision	Narrow-Shelf Mountainous (California)	15%	35%	60%	80%	10%	25%	50%	65%
2. Trailing- Edge	Wide-Shelf Plains (Duck, NC)	12%	30%	50%	65%	8%	25%	45%	55%
3. Marginal Sea	a) Narrow-Shelf Mountainous (Korea)	10%	22%	40%	59%	6%	18%	38%	46%
	b) Wide-Shelf Plains (Corpus Christi)	5%	15%	19%	33%	3%	8%	12%	27%
	c) Deltaic Tideless (Mississippi)	75%	95%	100%	100%	70%	90%	100%	100%
	d) Deltaic Tidal (Bangladesh)	75%	85%	90%	100%	70%	80%	85%	100%
4. Arctic Form of Cryogenic	Wide-Shelf Plains Ice-push & gouging (Flaxman Barrier)	10% to 100%	10% to 100%	10% to 100%	10% to 100%	5% to 100%	5% to 100%	5% to 100%	5% to 100%
5. Coral Reef Form of Biogenic	Fringing Reef (Hawaii)	12%	28%	48%	60%	7%	20%	40%	50%

a Based on depth of 7.5 m (mid VSW zone 3-12 m) and assumed mine specific gravity of 1.55.

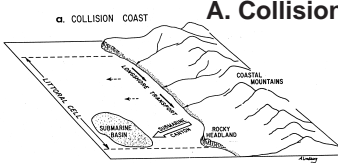
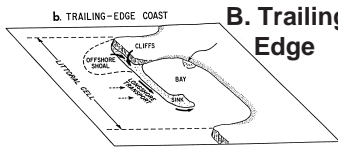
b Refer to Table 1-1 and Figure 1-1 for mine description.

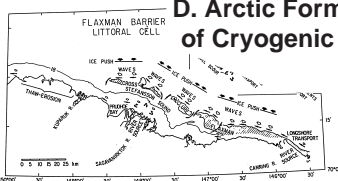
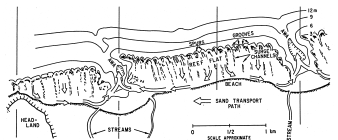
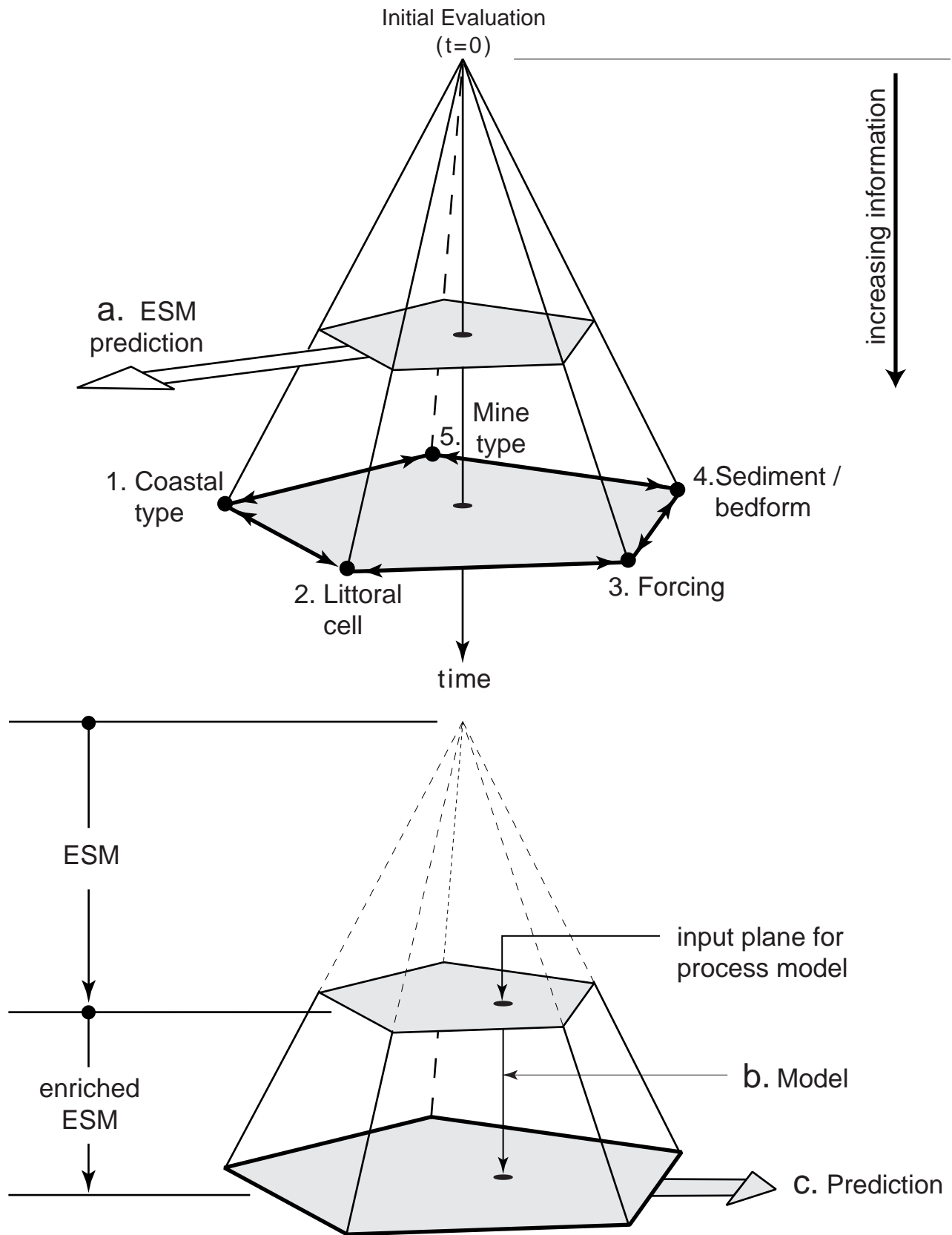

Figure 4-1. Hierarchy in the pyramid of interactive inputs for mine burial prediction using a combination of process and expert systems modeling (ESM).

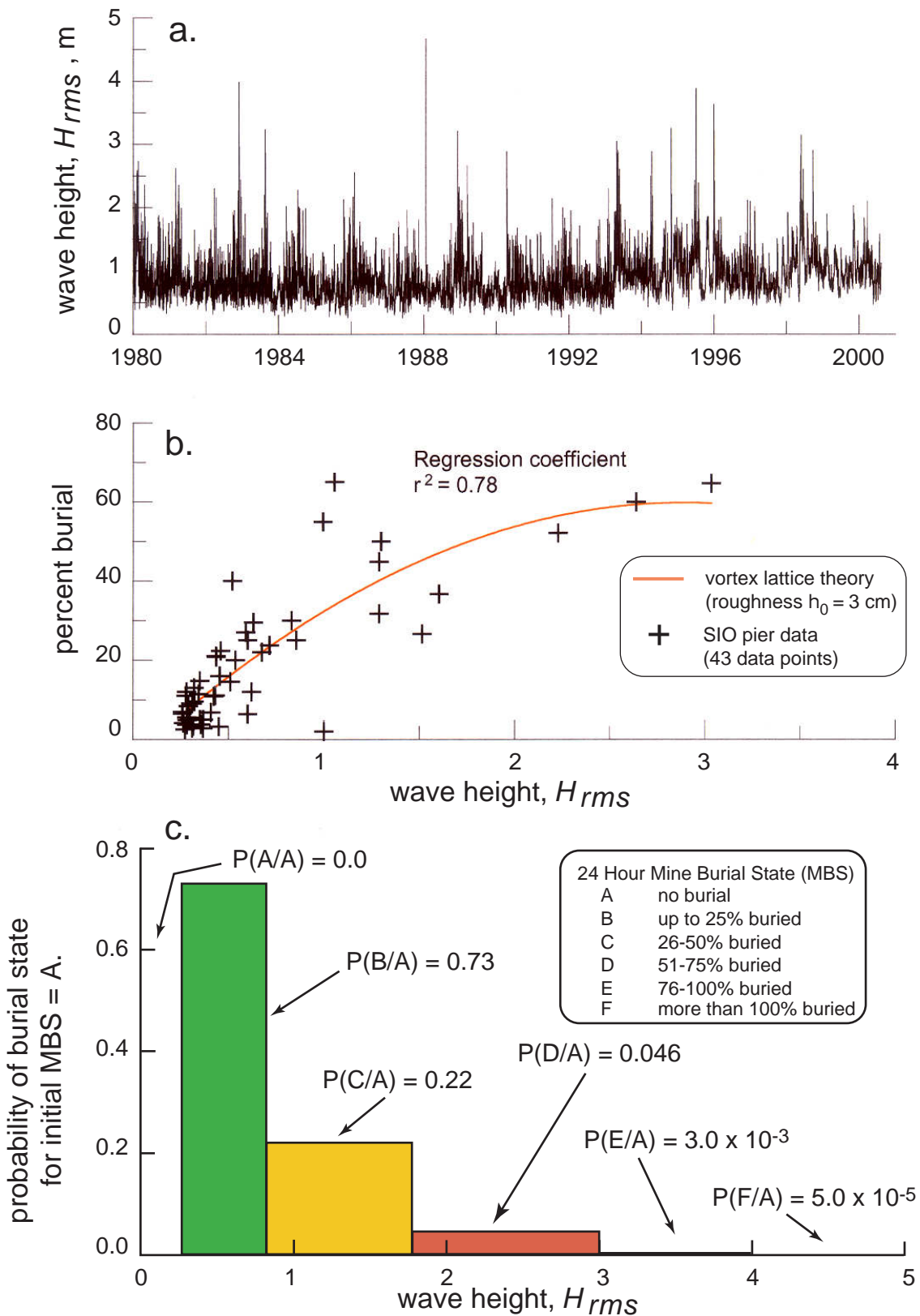

Figure 4-2. Probability of mine burial state (MBS) of MANTA mine, depth 7m. a) Wave climate history at Scripps Pier test site; b) twenty-four hour burial vs wave height; c) conditional probability of mine burial states A-F given initial burial state A. [after Jenkins and Inman, 2002]

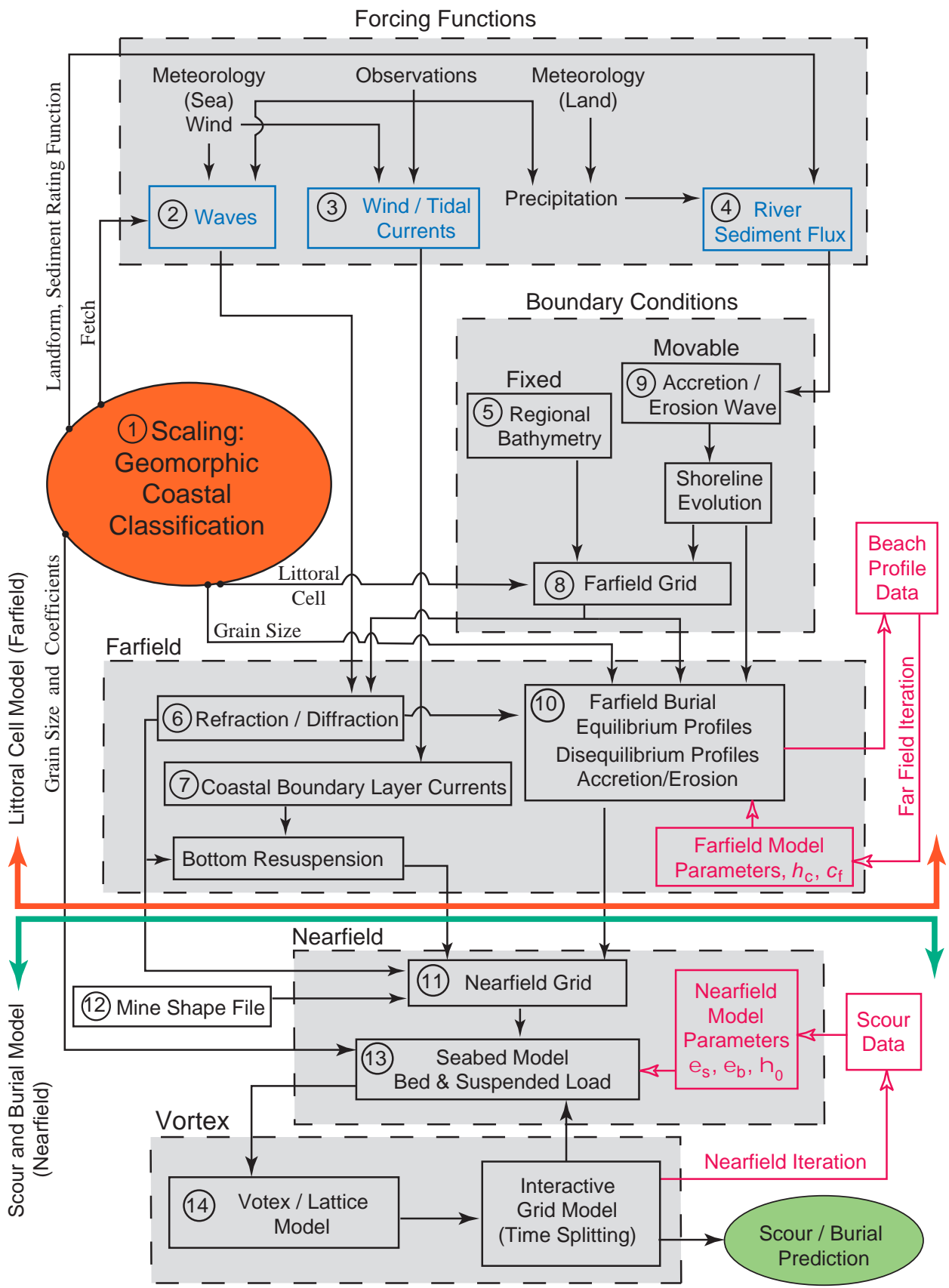
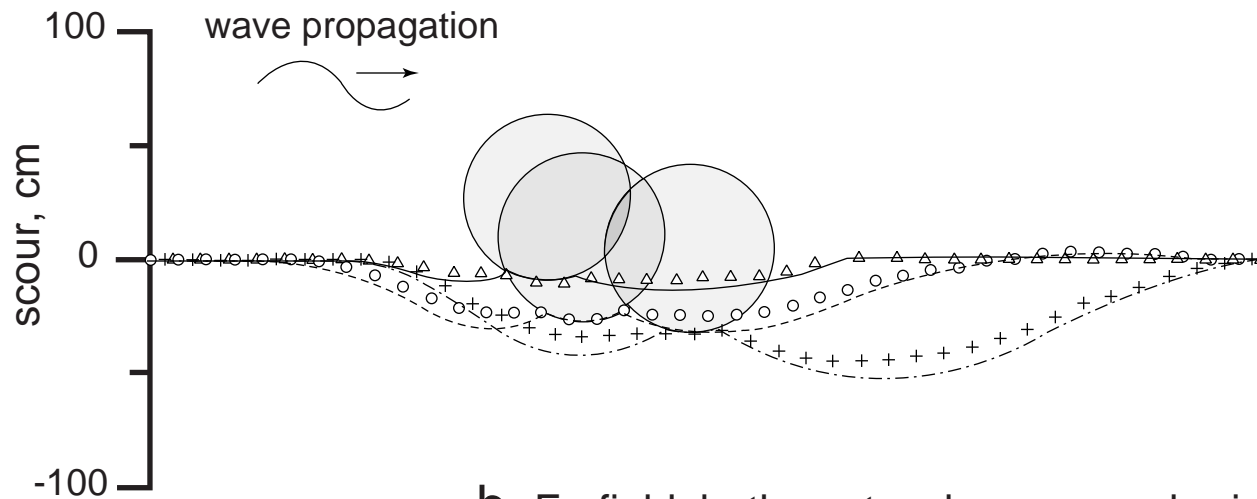

Figure 4-3. Architecture of the Vortex Lattice Mine Scour/Burial (VORTEX) Model. Model details are discussed in the text. [from Jenkins and Inman, 2002]

a. Nearfield: scour & burial



b. Farfield: bathymetry change → burial & exposure

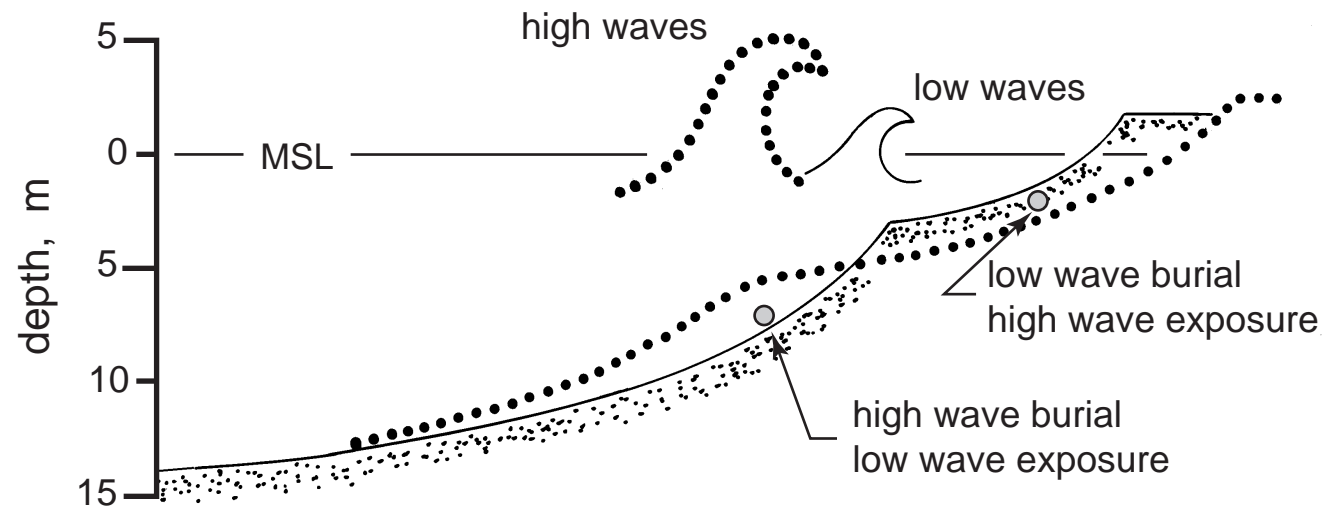

Figure 4-4. Mechanics of burial and exposure of seafloor objects. (a) Nearfield scour and burial, and (b) farfield bathymetry changes due to seasonal profile changes and/or net decrease/increase in source material.



Figure 4-5. Streams carry erosion products from the land to the sea; El Moreno, Gulf of California, Mexico (cf Figure 4-6). [from Inman and Jenkins, in press 2002c].

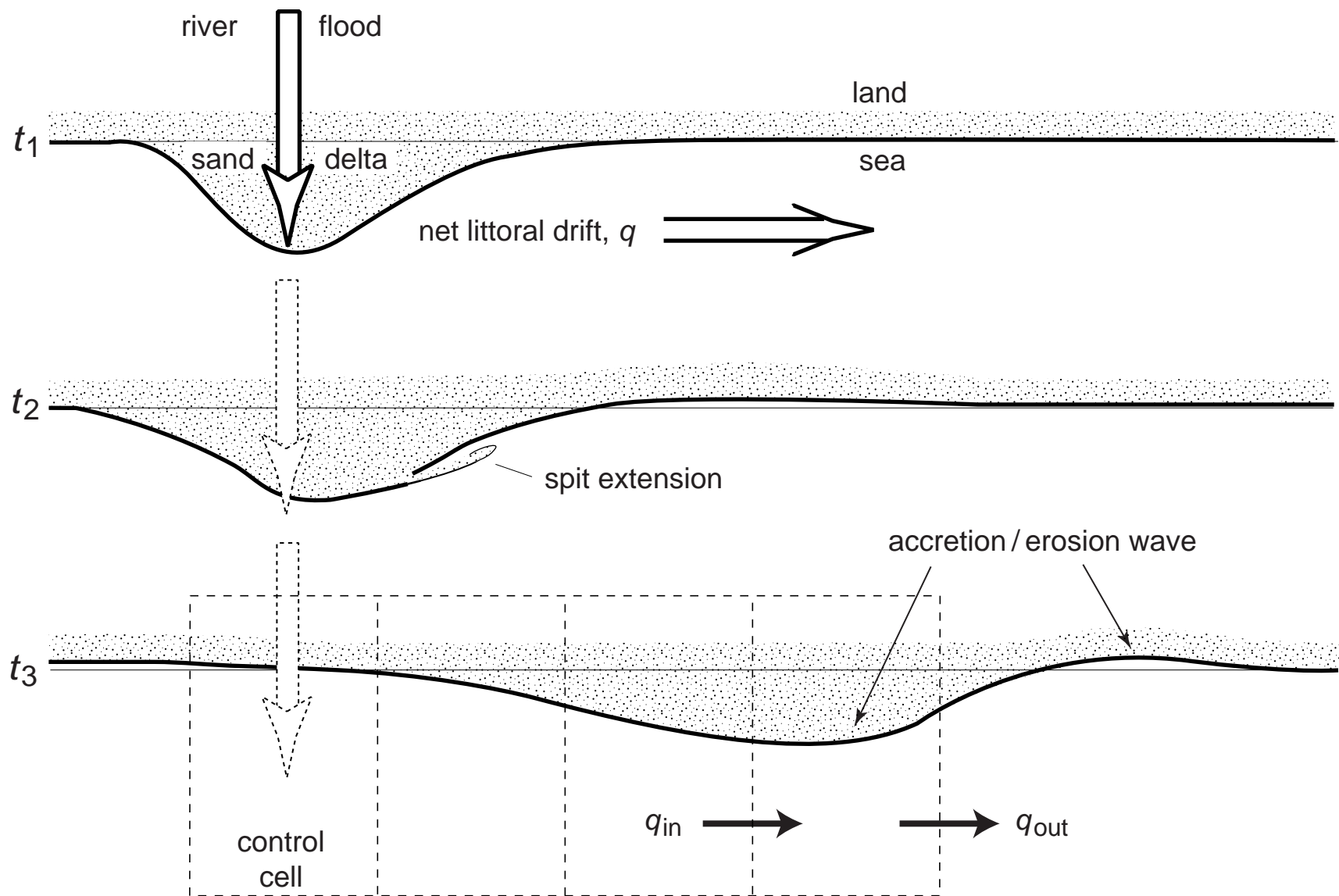

Figure 4-6. Formation of accretion/erosion wave down-drift from an episodically formed sand delta at time t_1 , where $t_1 < t_2 \ll t_3$. Control cells shown by dashed lines with local balance of sediment flux q_{in} vs q_{out} . [after Inman, in press 2002]

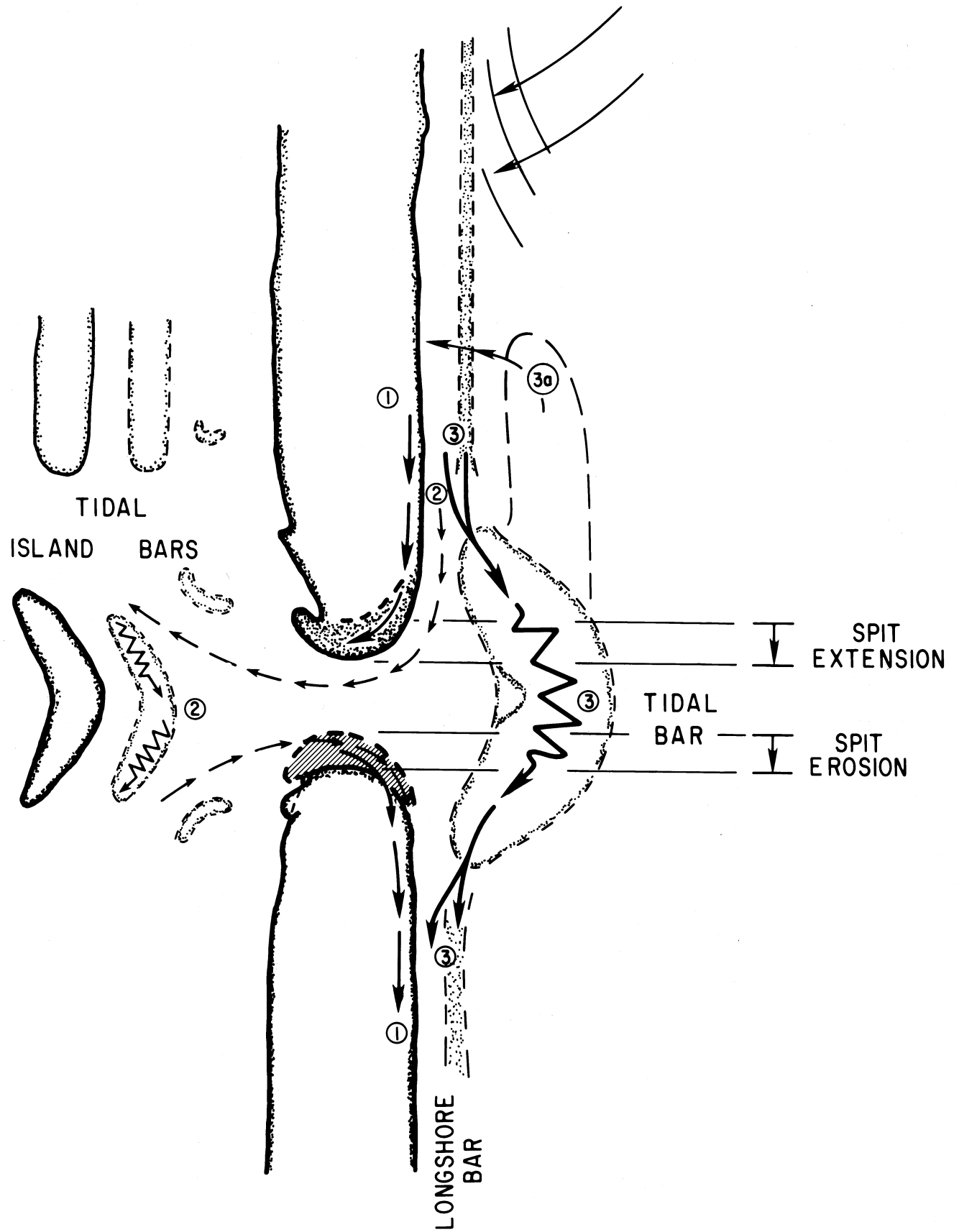

Figure 4-7. Schematic diagram of sediment transport paths across a migratory inlet. See text for explanation. [after Inman and Dolan, 1989]

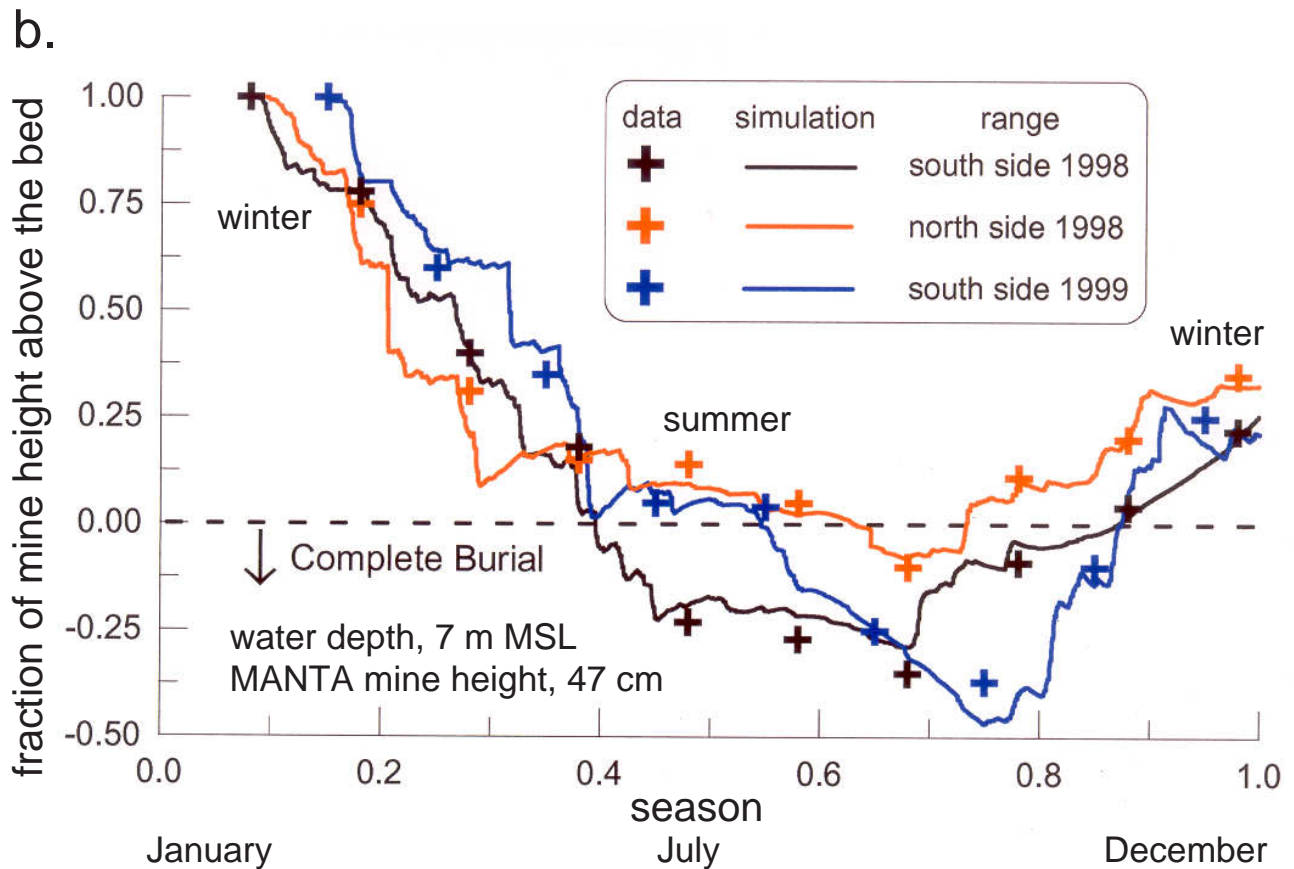
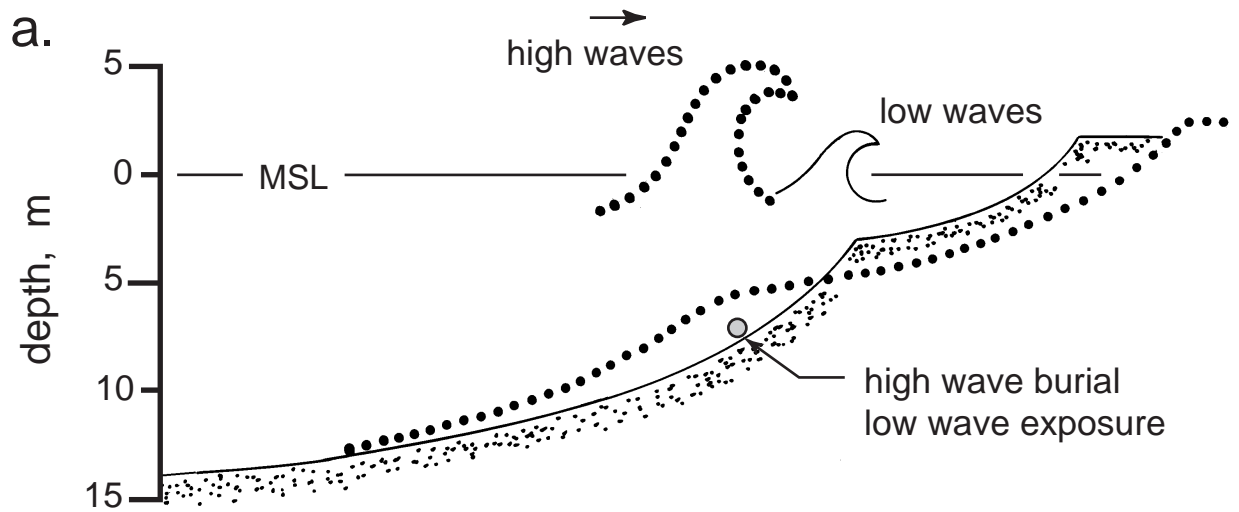

Figure 4-8. Farfield effects on mine burial. (a) Beach profile changes due to seasonal wave climate. (b) Burial and exposure of MANTA mine associated with seasonal profile changes off Scripps Pier. [from Jenkins and Inman, 2002]

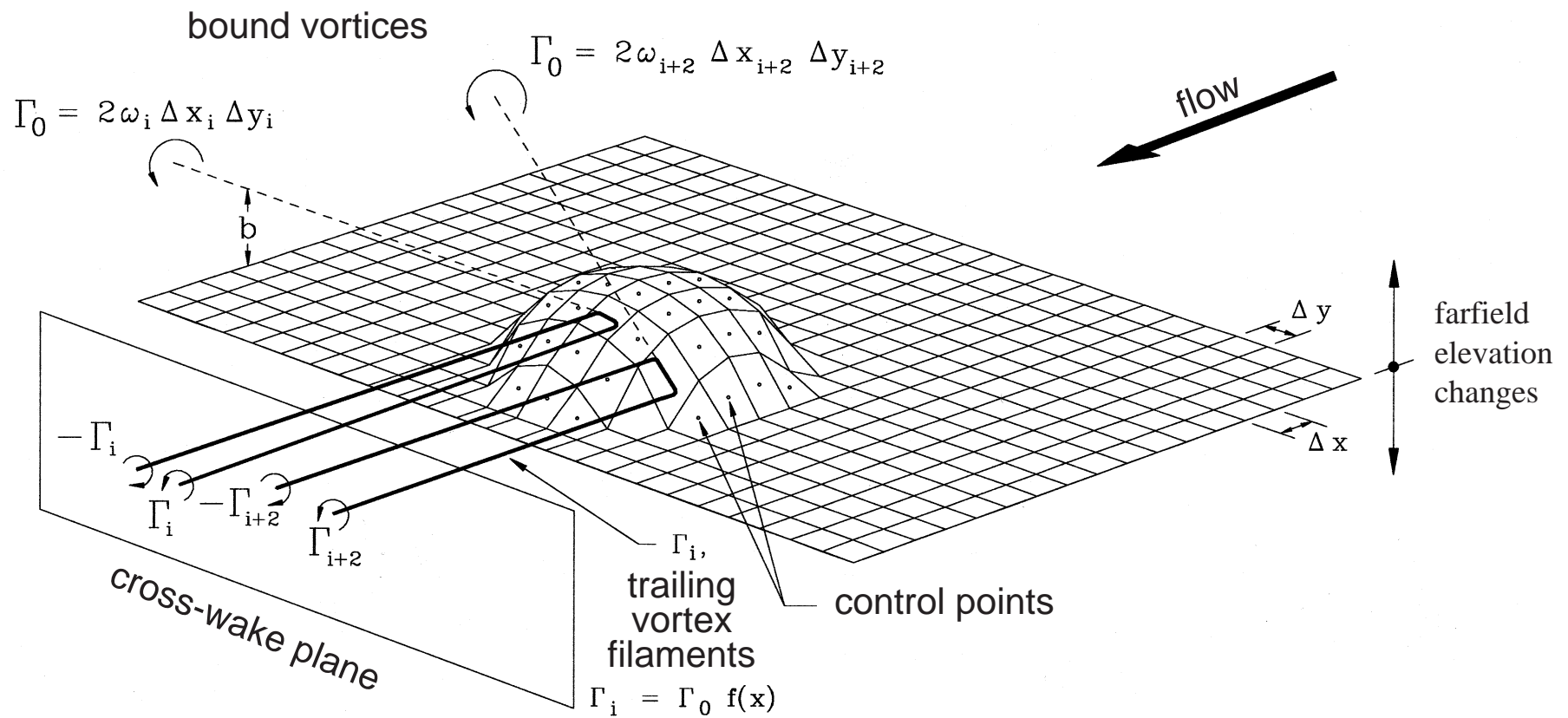

Figure 4-9. Vortex lattice method for predicting the vortex field of a body of arbitrary shape resting on the seabed (cf Figure 4-3, (14)). [after Inman and Jenkins, 1996]

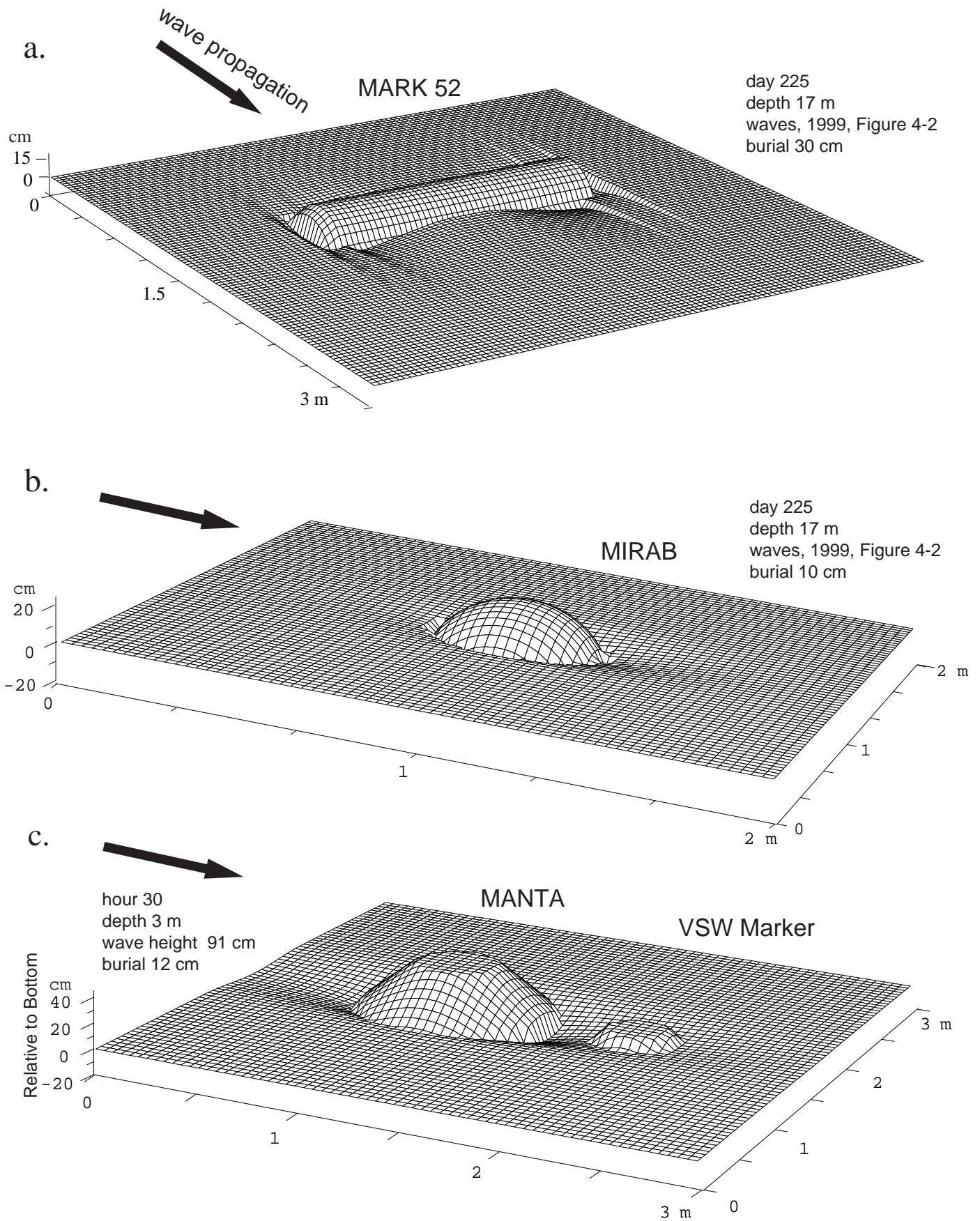

Figure 4-10. Examples of shape resolution by the VORTEX Model. Scour burial for a) cylinder, b) oblate hemispheroid, and c) truncated cones.

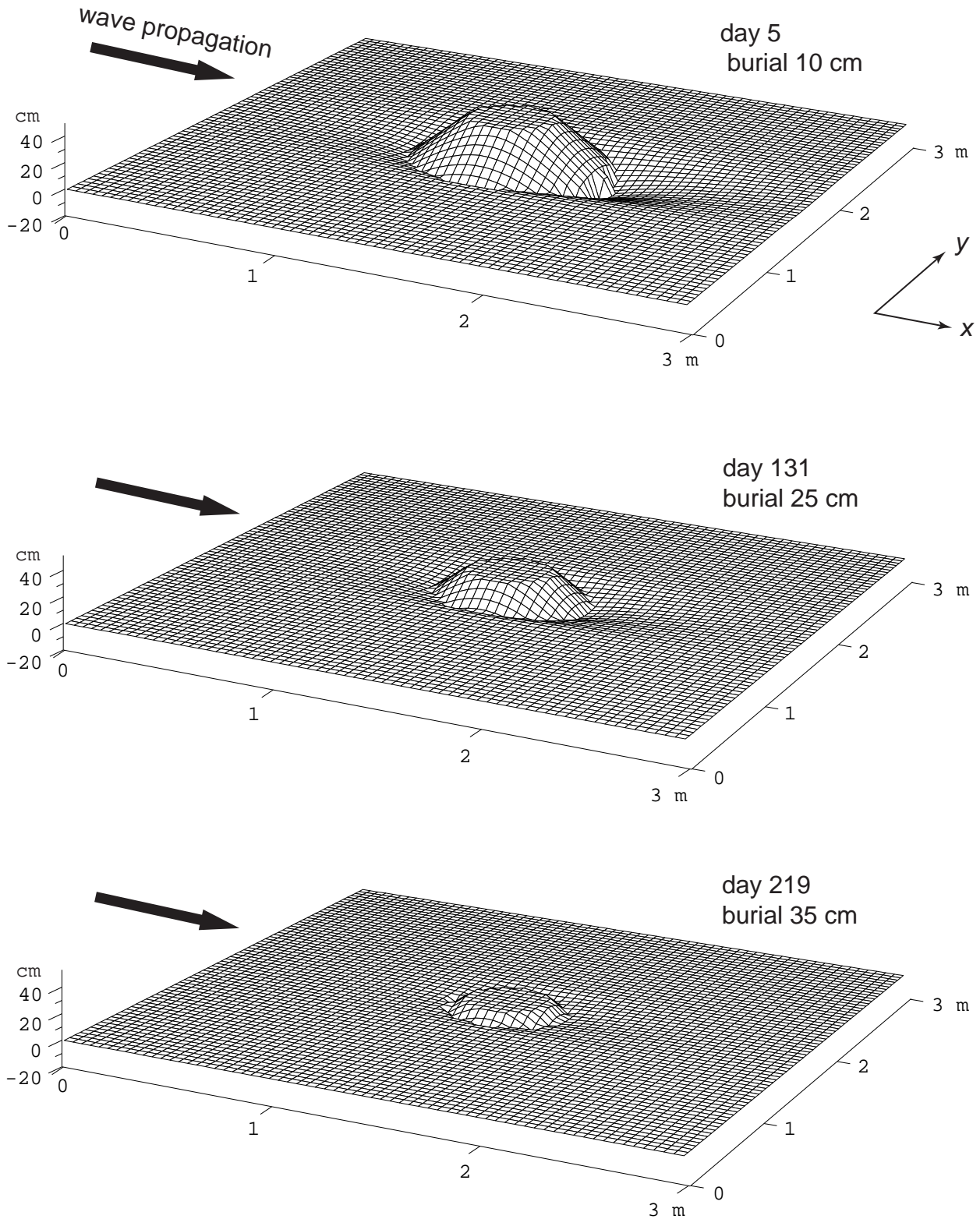

Figure 4-11. VORTEX model simulation of burial of a MANTA mine in waterdepth of 7 m subject to waves measured at Scripps Pier. [from Jenkins and Inman, 2002]

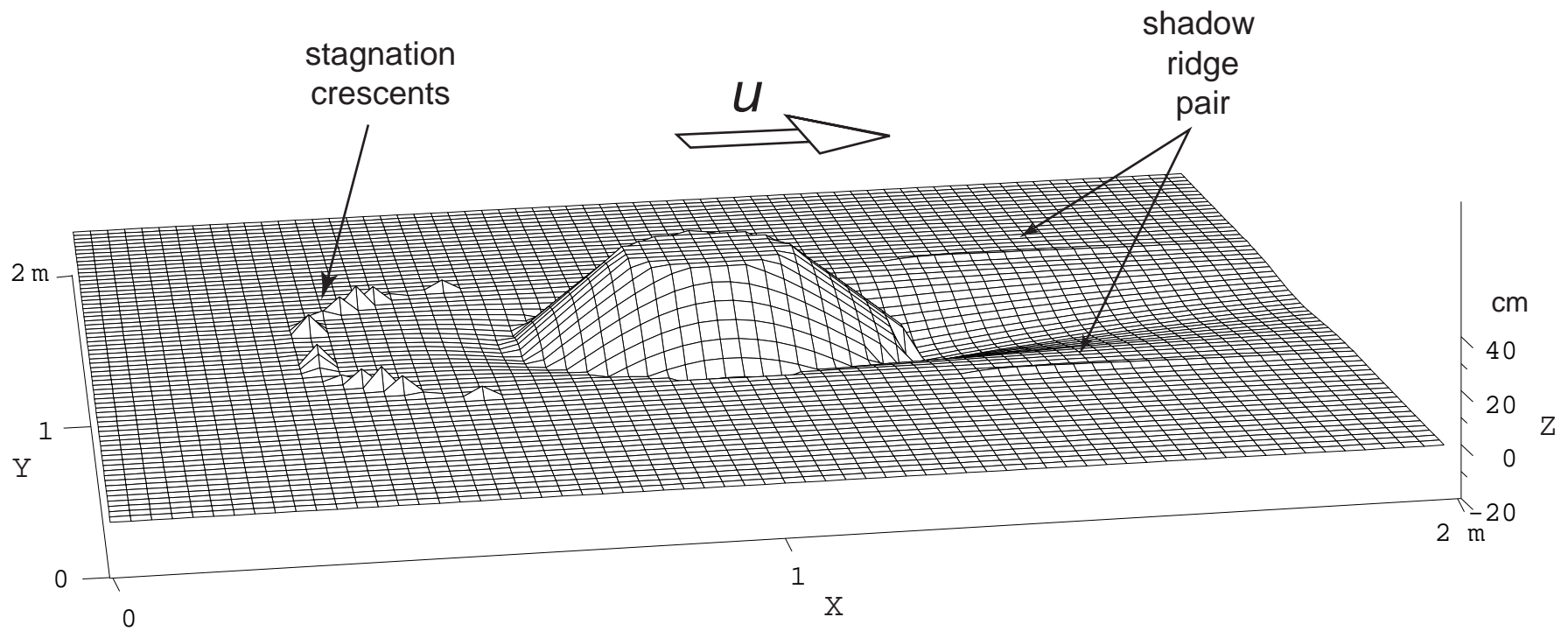

Figure 4-12. VORTEX model simulation of MANTA mine buried by unidirectional water flow with associated bedforms; current 40 cm/sec, median grain size 250 mm. [from Jenkins and Inman, 2002]

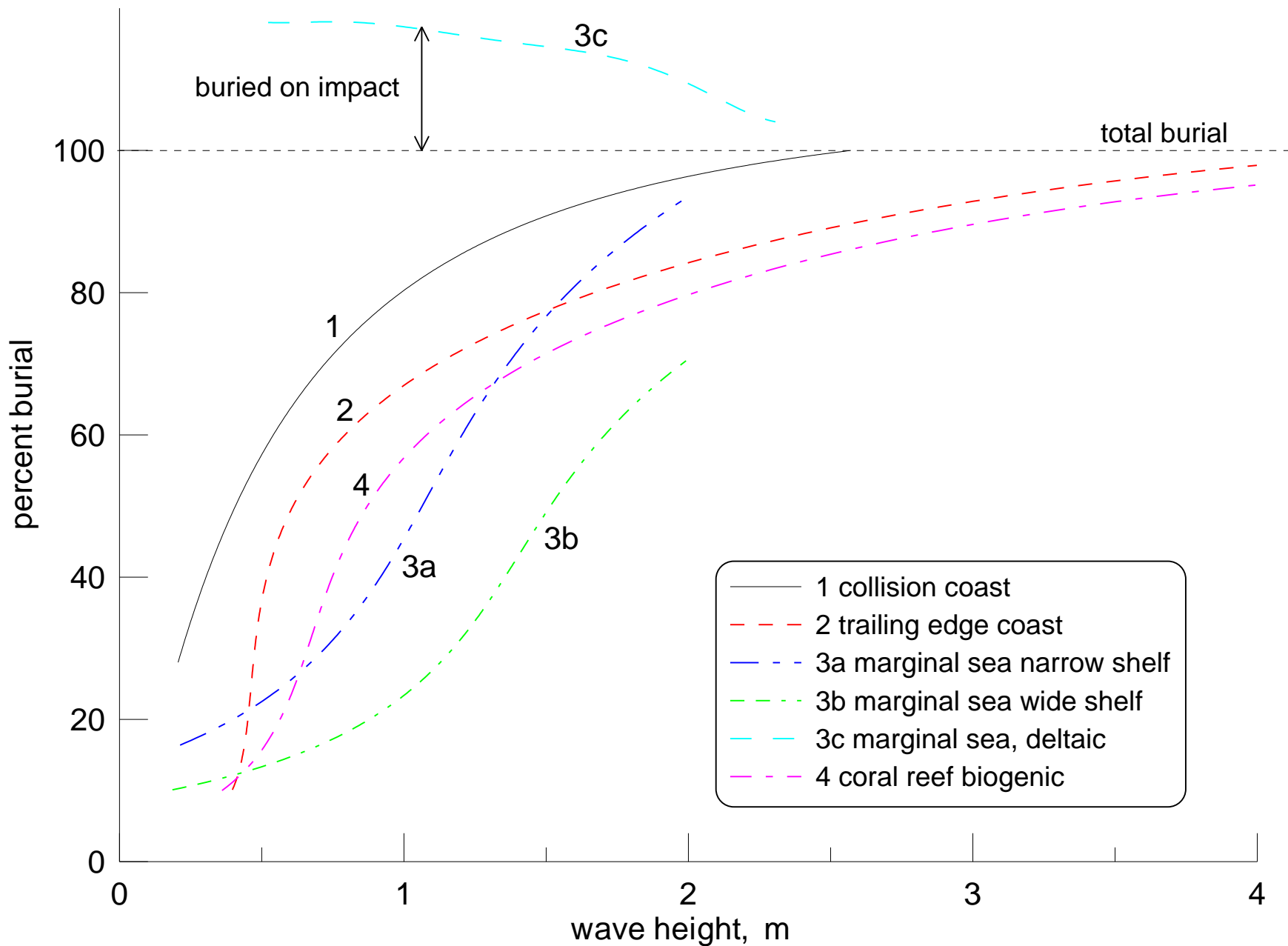

Figure 4-13. Predicted 30-day burial by waves of a MARK 52 mine in water depth of 7 m along various types of exposed coast. Closure depth, sediment type and bottom roughness from Table 4-1, wave forcing from Table A-1.

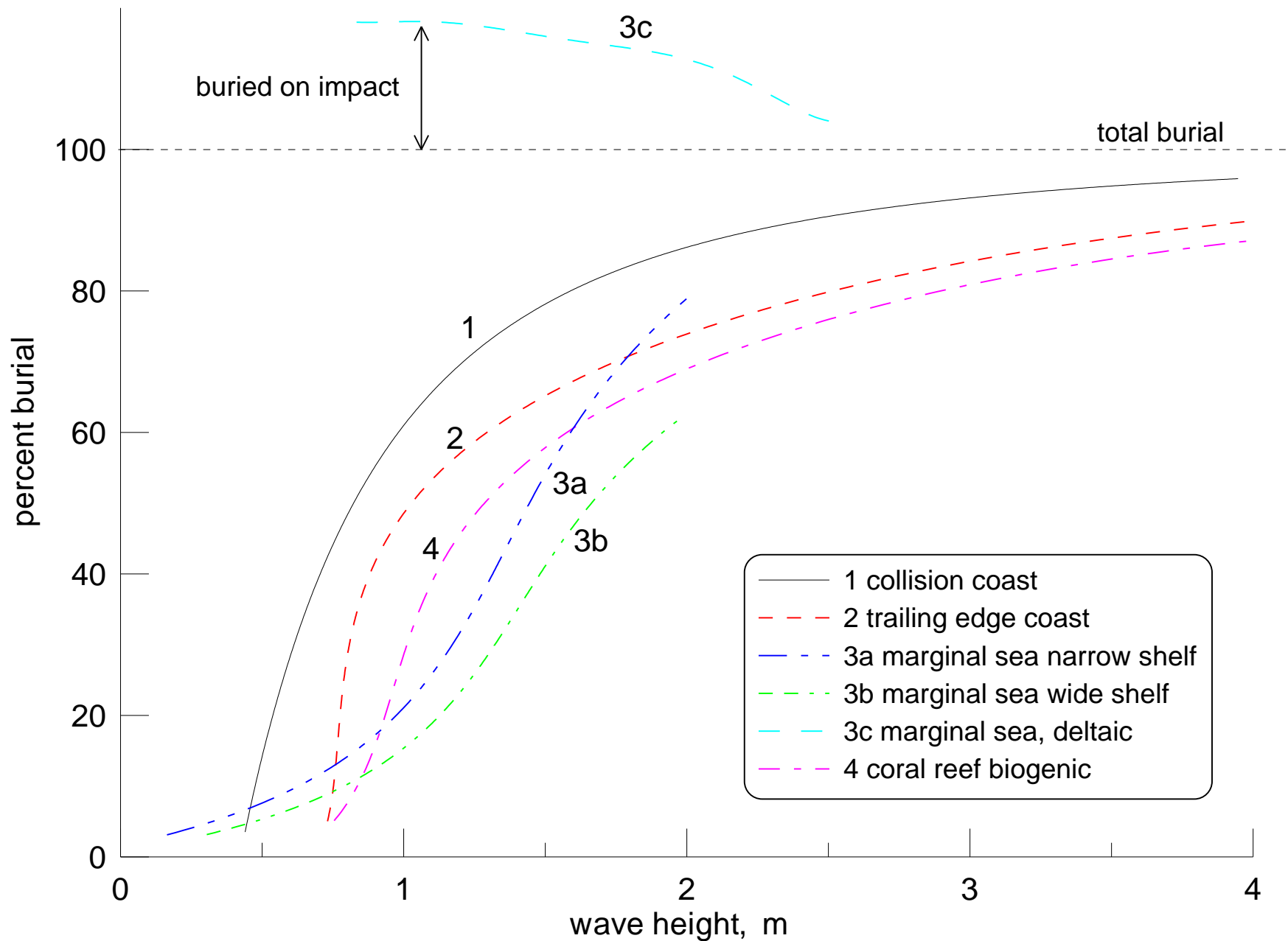

Figure 4-14. Predicted 30-day burial by waves of a MANTA mine in water depth of 7 m along various types of exposed coast. Closure depth, sediment type and bottom roughness from Table 4-1, wave forcing from Table A-1.

5. REFERENCES

- Aijaz, S. and S. A. Jenkins, 1994, On the electrokinetics of the dynamic shear stress in fluid mud suspensions, *Jour. Geophys. Res.*, v. 99, n. C6, p.12,697-706.
- Allen, J. R. L., 1984, *Sedimentary Structures, Their Character and Physical Basis*, Elsevier, Amsterdam.
- Allen, J. R. L., 1985, *Principles of Physical Sedimentology*, George Allen & Unwin, London, Boston.
- Bagnold, R. A., 1941, *The Physics of Blown Sand and Desert Dunes*, William Morrow & Company, New York.
- Barnes, P. W., E. Reimnitz and D. M. Schell, (eds.), 1984, *The Alaskan Beaufort Sea-Ecosystems and Environments*, Academic Press, Orlando, FL.
- Bascom, W. and J. Fry, 1953, The movement and burial of cylindrical ground mines on sandy bottoms, *University of California, San Diego*, Scripps Institution of Oceanography, Ref. No. 53-17.
- Bennett, R. H. and R. Dolan (with 6 contributing authors), January 2001, Mine burial assessment state-of-the-art science, technology, and modeling: A review of coastal research, modeling, and Naval Operational needs in shallow water environments with recommendations, *Seaprobe Inc.*, Technical Report No. 51-0099-05, 99 pp.
- Breusers, H. N. C., G. Nicollet and H. W. Shen, 1977, Local scour around cylindrical piers, *Journal of Hydraulic Research*, v. 15, p. 211-52.
- Brown, L. K., 1991, *Mine Countermeasures and Amphibious Operations: A Line in the Sea?*, Naval War College, Newport, RI, 32 pp.
- Burt, W. V., M. C. Powers and D. W. Pritchard, 1952, Operation Mud - results of studies of mine penetration in the York River, *Johns Hopkins Univ.*, Chesapeake Bay Institute, Ref. No. 52-25.

- Chiew, Y. M. and B. W. Melville, 1987, Local scour around bridge piers, *Journal of Hydraulic Research*, v. 25, p. 15-26.
- Chu, P. C., A. F. Gilles, C. Fan and P. Fleischer, 2002, Hydrodynamics of falling mine in water column, *Jour. Counter-Ordnance Technology*, 5th Int. Symposium on Technology and Mine Problem, e-journal@
<http://www.demine.org/SCOT/Papers/pdfpapers.html>, p. 1-9.
- Collins, T. J., 1980, Investigating bridge scour, *Railway Track and Structure*, 76 pp.
- Davis, R. A. Jr., 1996, *Coasts*, Prentice Hall, Upper Saddle River, NJ.
- Dill, R. F., 1958, The burial and scouring of ground mines on a sandy bottom, *U. S. Navy Electronics Laboratory*, San Diego, CA, Research Report NEL 861, 32 pp. (now unclassified)
- Donohue, H., 1998, Mine warfare operations in tomorrow's Asia-Pacific, p. 166-79 in J. McCaffrie and A. Hinge (eds.), *Sea Power in the New Century: Maritime Operations in Asia-Pacific Beyond 2000*, Australian Defence Studies Centre, University College, ADFA, 225 pp.
- Donohue, J. J. and L. E. Garrison, 1954, An evaluation of mine behavior observations in four test areas, *Univ. Rhode Island, Narragansett Marine Laboratory*, Reference 54-13, 79 pp.
- Duncan, R. C., 1962, *America's Use of Sea Mines*, U. S. Naval Ordnance Laboratory, White Oak, MD, 173 pp.
- Elliott, P., 1979, *Allied Minesweeping in World War 2*, Naval Institute Press, Annapolis, MD, 201 pp.
- Exercise Curlew, 1948, *Great Britain*, First Mine sweeping experimental flotilla, Report of Exercise CURLEW, 2 May - 11 November 1948.
- Foxwell, D., 1991, New technology takes on the sea mine, *International Defense Review*, October, p. 1097-99/1101-102.

- Frazier, D. E. and C. E. Miller, 1955, Geological and engineering characteristics at mine behavior test sites, *Univ. Rhode Island, Narragansett Marine Laboratory*, Reference 55-16, 22 pp. + appen.
- Friedman, N., 1982, *U. S. Naval Weapons: Every Gun, Missile, Mine and Torpedo Used by the U. S. Navy From 1883 to the Present Day*, Naval Institute Press, Annapolis, 287 pp.
- Friedman, N., 1998, Operational and technological developments in underwater warfare, p. 158-65 in J. McCaffrie and A. Hinge (eds.), *Sea Power in the New Century: Maritime Operations in Asia-Pacific Beyond 2000*, Australian Defence Studies Centre, University College, ADFA, 225 pp.
- Fulton, W. B., 1973, *Vietnam Studies Riverine Operations, 1966-1969*, Department of the Army, Washington, DC, 210 pp.
- Garrison, L. E. and D. E. Frazier, 1954, Geology of mine behavior test areas (Addendum-Charlie Area), *Univ. Rhode Island, Narragansett Marine Laboratory*, Reference 54-21, 18 pp.
- Gregory, B., 1988, *Vietnam Coastal and Riverine Forces Handbook*, Patrick Stephens, Irthlingborough, UK, 135 pp.
- Hartmann, G. K., 1991, *Weapons That Wait: Mine Warfare in the U. S. Navy*, Naval Institute Press, Annapolis, MD, 294 pp.
- Henderson, F. M., 1966, *Open Channel Flow*, The Macmillan Company, New York.
- Inman, D. L., 1953, Areal and seasonal variations in beach and nearshore sediments at La Jolla, California, *U. S. Army Corps of Engineers*, Beach Erosion Board, Tech. Memo 39, 134 pp.
- Inman, D. L., 1957, Wave-generated ripples in nearshore sands, *U. S. Army Corps of Engineers*, Beach Erosion Board, Technical Memo 100, 65 pp.

- Inman, D. L., 1987, Accretion and erosion waves on beaches, *Shore & Beach*, v. 55, n. 3/4, p. 61-66.
- Inman, D. L., 1994, Types of coastal zones: similarities and differences, p. 67-84 in *Environmental Science in the Coastal Zone*, National Research Council, Washington, D. C., 172 pp.
- Inman, D. L., in press 2002, Littoral cells, in M. Schwartz, ed., *Encyclopedia of Coastal Science*, Kluwer Academic Publishers, Dordrecht, Netherlands.
- Inman, D. L. and G. A. Rusnak, 1956, Changes in sand level on the beach and shelf at La Jolla, California, *U. S. Army Corps of Engineers*, Beach Erosion Board, Tech. Memo. 82, 64 pp.
- Inman, D. L. and A. J. Bowen, 1962, Flume experiments on sand transport by waves and currents, *Proc. 8th Conf. Coastal Engineering*, Council on Wave Research, University of California, p. 137-150.
- Inman, D. L. and R. A. Bagnold, 1963, Littoral processes, p. 529-553 in M. N. Hill (ed.), *The Sea*, v. 3, *The Earth Beneath the Sea*, Interscience, John Wiley and Sons, New York, London, 963 pp.
- Inman, D. L. and C. E. Nordstrom, 1971, On the tectonic and morphologic classification of coasts, *Jour. of Geology*, v. 79, n. 1, p. 1-21.
- Inman, D. L. and B. M. Brush, 1973, The Coastal Challenge, *Science*, v. 181, n. 4094, p. 20-32.
- Inman, D. L. and S. A. Jenkins, 1984, The Nile littoral cell and man's impact on the coastal zone of the southeastern Mediterranean, p. 1600-17 in *Proc. 19th Coastal Engineering Conf.*, v. 2, Amer. Soc. Civil Engineering.
- Inman, D. L. and R. Dolan, 1989, The Outer Banks of North Carolina: Budget of sediment and inlet dynamics along a migrating barrier system, *Jour. Coastal Research*, v. 5, n. 2, p. 193-237.

- Inman, D. L. and P. M. Masters, 1991, Budget of sediment and prediction of the future state of the coast, Chapter 9, (105 pp.) in *State of the Coast Report, San Diego Region, Coast of California Storm and Tidal Waves Study*, U. S. Army Corps of Engineers, Los Angeles District, Chapters 1-10, Appen. A-Q.
- Inman, D. L. and P. M. Masters, 1994, Status of research on the nearshore, *Shore & Beach*, v. 62, n. 3, p. 11-20.
- Inman, D. L. and S. A. Jenkins, 1996, A chronology of ground mine studies and scour modeling in the vicinity of La Jolla, *University of California, San Diego*, Scripps Institution of Oceanography, SIO Reference Series 96-13, 26 pp.
- Inman, D. L. and S. A. Jenkins, 1997, Changing wave climate and littoral drift along the California coast, p. 538-549 in O. T. Magoon et al., eds., *California and the World Ocean '97*, ASCE, Reston, VA, 1756 pp.
- Inman, D. L. and S. A. Jenkins, in press 2002a, Scour and burial of objects in shallow water, in M. Schwartz, ed., *Encyclopedia of Coastal Science*, Kluwer Academic Publishers, Dordrecht, Netherlands.
- Inman, D. L. and S. A. Jenkins, in press 2002b, Accretion and erosion waves on beaches, in M. Schwartz, ed., *Encyclopedia of Coastal Science*, Kluwer Academic Publishers, Dordrecht, Netherlands.
- Inman, D. L. and S. A. Jenkins, in press 2002c, Energy and sediment budgets of the global coastal zone, in M. Schwartz, ed., *Encyclopedia of Coastal Science*, Kluwer Academic Publishers, Dordrecht, Netherlands.
- Inman, D. L., W. R. Gayman and D. C. Cox, 1963, Littoral sedimentary processes on Kauai, a subtropical high island, *Pacific Science*, v. 17, n. 1, p. 106-130.
- Inman, D. L., M. H. S. Elwany, A. A. Khafagy and A. Golik, 1992, Nile Delta profiles and migrating sand blankets, *Proc. 23rd Coastal Engineering Conf.*, ASCE, New York, p. 3273-84, v. 3.

Inman, D. L., M. H. S. Elwany and S. A. Jenkins, 1993, Shorerise and bar-berm profiles on ocean beaches, *Jour. Geophysical Res.*, v. 98, n. C10, p. 18,181-199.

Jenkins, S. A. and D. L. Inman, 2002, Model for mine scour and burial: an illustrated abstract with technical appendix, *University of California, San Diego*, Scripps Institution of Oceanography, SIO Reference Series 02-2, 42 pp.

Kirman, J., K. Basye and T. Dean, 1991, Sensor abstractions for control of navigation, p. 2812-7 in *Proceedings of the IEEE International Conference on Robotics and Automation*, IEEE, New York.

Klein, P., S. A. Plotkin, C. Stein and E. Tardos, 1991, Faster approximation algorithms for the unit capacity concurrent flow problem with applications to routing and finding sparse cuts, *Cornell Univ.*, Schools of Operations Research and Industrial Engineering, Technical Report 961.

Levie, H. S., 1992, *Mine Warfare at Sea*, M. Nijhoff, Boston, MA, 216 pp.

McCormick, B. W., 1979, *Aerodynamics, Aeronautics and Flight Mechanics*, John Wiley & Sons, New York, 652 pp.

McLeroy, E. G. and G. G. Salsman, 1987, Sensitivity to environmental inputs and effectiveness of mine burial prediction models, prepared for Naval Coastal Systems Center, Panama City, Florida 32407, by *Planning Systems Inc.*, #3 Miracle Strip Loop, Panama City, Florida, 43 pp.

McMaster, R. L., L. E. Garrison and S. D. Hicks, 1955, Marine sedimentation project; mine behavior studies, *Univ. Rhode Island, Narragansett Marine Laboratory*, Reference 55-15, 38 pp. + 5 photos.

Melia, T. M., 1991, *Damn the Torpedoes, A Short History of U. S. Naval Mine Countermeasures, 1777-1991*, Naval History Center, Dept. of the Navy, Washington, DC, 209 pp.

- MOMAG, Sept. 2000, U. S. Navy Mine Familiarizer, *Mobile Mine Assembly Group, NAVSEA (Naval Sea Systems Command)*.
www.comomag.navy.mil/famil_his_frame.htm
- Morison, S. L., 1995, *Guide to Naval Mine Warfare*, Pasha Publications, Arlington, VA, 432 pp.
- Mulhearn, P. J., 1993a, Experiment on mine burial by scour, *Materials Research Laboratory*, Maribyrnong, Victoria 3032, Australia, MRL-TN-632, 24 pp.
- Mulhearn, P. J., 1993b, Experiments on mine burial on impact-Sydney Harbour, *U. S. Navy Journal of Underwater Acoustics*, v. 43, n. 3, p. 1271-81.
- Mulhearn, P. J., 1995, An experiment on mine burial by seabed scouring under wave action, *Aeronautical and Maritime Research Laboratory*, Melbourne, Victoria 3001, Australia, DSTO-TN-0006, 13 pp.
- Murray, S., J. M. Coleman, H. H. Roberts and M. Salama, 1981, Accelerated currents and sediment transport off the Damietta Nile promontory, *Nature*, 293, 51-54.
- Naidu, A. S., T. C. Mowatt, S. E. Rawlinson, and H. V. Weiss, 1984, Sediment characteristics of the lagoons of the Alaskan Beaufort Sea coast and evolution of Simpson Lagoon, in P. W. Barnes et al. (eds.), *The Alaskan Beaufort Sea, Ecosystems and Environments*, Academic Press, Orlando, FL, p. 275-292.
- NAVO, 1996, *Mine Warfare Pilot, East China Sea*, Naval Oceanographic Office, Stennis Space Center, Special Publication SP-813, CONFIDENTIAL.
- Neelin, J. D., M. Latif, and F.-F. Jin, 1994, Dynamics of coupled ocean-atmosphere models: The tropical problem, *Annu. Rev. Fluid Mech.*, p. 617-59.
- Nemhauser, G. L., A. H. G. Rinnooy Kan and M. J. Todd, (eds.), 1989, *Optimization: Handbooks in Operations Research and Management Science*, vol. 1, North-Holland, Amsterdam, The Netherlands.

- Nishizawa, M. and M. Sawamoto, 1988, Local scour around a vertical cylinder under the wave action, p. 121-8, in *Proceedings of the 6th Congress of Advanced Ports Design*, International Association of Harbor Research.
- Oreskes, N., K. Shrader-Frechette and K. Belitz, 1994, Verification, validation, and confirmation of numerical models in the earth sciences, *Science*, v. 263, p. 641-26.
- Patterson, A., 1970, *A Brief History of Mine Warfare*, National Academy of Sciences, Mine Advisory Committee, Washington, DC, 49 pp.
- Pettijohn, F. J. and P. E. Potter, 1964, *Atlas and Glossary of Primary Sedimentary Structures*, Springer-Verlag, New York.
- Raudkivi, A. J., 1990, *Loose Boundary Hydraulics*, Pergamon Press, Oxford.
- Reimnitz, E. and E. Kempema, 1983, High rates of bedload transport measured from infilling rate of large strudel-scour craters in the Beaufort Sea, Alaska, *Continental Shelf Res.*, v. 1, p. 237-251.
- Reineck, H.-E. and I. B. Singh, 1975, *Depositional Sedimentary Environments*, Springer-Verlag, New York.
- Salsman, G. G. and W. H. Tolbert, 1962, A summary of ground mine behavior characteristics, *U. S. Navy Mine Defense Laboratory (now Naval Coastal Systems Station)*, Panama City, Florida, 54 pp.
- Salsman, G. G. and W. H. Tolbert, 1966, A seafloor burial experiment conducted off Panama City, Florida, *U. S. Navy Mine Defense Laboratory (now Naval Coastal Systems Station)*, Technical Note 75, 11 pp.
- Santos, Jr., E., 1996, On linear potential functions for approximating Bayesian computations, *Jour Assoc. Computing Machinery*, v. 43, n. 3, p. 399-430.
- Satkowiak, L. J., 1987, User's guide for the modified impact burial prediction Model, *Naval Coastal Systems Center*, Panama City, FL, TN884-87.

- Schlichting, H., 1979, (7th ed.) *Boundary-Layer Theory*, McGraw-Hill Book Co., New York.
- Shen, H. W., V. R. Schneider, and S. Karaki, 1969, Local scour around bridge piers, *Journal of the Hydraulics Division*, American Society of Civil Engineers, v. 95, p. 1919-40.
- Southard, J. B. and J. R. Dingler, 1971, Flume study of ripple propagation behind mounds on flat sand beds, *Sedimentology*, v. 16, p. 251-63.
- Stoker, J. J., 1957, *Water Waves, the Mathematical Theory with Applications*, Interscience Publishers, Inc., New York.
- Subgroup 31, 1999, *Mine Burial Prediction, Analysis and Final Report*, Subgroup 31, North Atlantic Treaty Organization (NATO), 100 pp. + Appen A & B.
- Sumer, B. M., J. Fredsoe, and N. Christiansen, 1992, Scour around vertical pile in waves, *Journal of Waterways, Port, Coastal and Ocean Engineering*, American Society of Civil Engineers, v. 118, p. 15-31.
- Tunstall, E. B. and D. L. Inman, 1975, Vortex generation by oscillatory flow over rippled surfaces, *Jour. Geophysical Res.*, v. 80, n. 24, p. 3475-84.
- U. S. Congress, 1988, House Committee on Armed Services, Seapower and Strategic and Critical Materials Subcommittee, *Mine Warfare*, 100th Congress 1st Session, Hearing Held September 17th 1987, U. S. Government Printing Office, 50 pp.
- Vincent, L. and R. Dolan, 2000, An expert systems approach to modeling mine behavior in coastal sedimentary environments, distributed 29-30 August 2000 at *Expert Systems Modeling Workshop*, Office of Naval Research-International Field Office, London, UK, 11 pp.
- Whitham, G. B., 1974, *Linear and Nonlinear Waves*, John Wiley & Sons, New York.

- Wiseman, W. J. Jr., J. M. Colema, A. Gregory, S. A. Hsu, A. D. Short, J. N. Suhayda, C. D. Walters and L. D. Wright, 1973, Alaskan arctic coastal processes and morphology, *Louisiana State University*, Technical Report 145, 171 pp.
- Zhang, N. L. and L. Yan, 1998, Independence of causal influence and clique tree propagation, *Int. Jour. Approximate Reasoning*, v. 19, p. 335-349.

Internet Sites Relevant to Mine Burial

The Airborne Mine Countermeasures [AMCM] Website

<http://members.aol.com/helmineron/>

[AMCM] Naval Mines

<http://members.aol.com/helmineron/min>

COMINEWARCOM Home Page

<http://www.cnsl.spear.navy.mil/cmwc/>

COMNAVSURFPAC Regional

<http://www.surfpac.navy.mil/pressrele>

Detection and Remediation Technologies for Mines and Mine

<http://www.spie.org/web/meetings/prog>

5th International Symposium on Technology and the Mine Problem

<http://www.demine.org/SCOT/Papers/pdfpapers.html>

Google Directory - Society Military Weapons and Equipment

<http://directory.google.com/Top/Socie>

Korean War--Wonsan Mine Clearance, October-November 1950

<http://www.history.navy.mil/photos/ev>

Littoral Sea Mine

http://www.ratheon.com/systems_integ

(MCM Mine Countermeasures Dets) Explosive Ordnance Disposal Units

<http://www.cnsl.spear.navy.mil/cmwc/E>

Mine Detection, Neutralization and Amphibious Assault

<http://www.chinfo.navy.mil/navpalib/c>

Mobile Mine Assembly Group (MOMAG)

<http://www.comomag.navy.mil>

ONR Mine Burial Prediction Program

<http://www.mbp.unh.edu>

Robo Lobster, Organic Mine Countermeasures

http://www.onr.navy.mil/sci_tech/futurenaval.htm

Sea Mines Countermeasures in the 20th Century

<http://web.nps.navy.mil/~library/bibs>

The Unofficial Mine Warfare

<http://www.ae.utexas.edu/~industry/mine/>

USA Mines

<http://www.warships1.com/Weapons/WAMU>

US Merchant Ships Sunk or Damaged by Mines in World War II

<http://www.usmm.org/mineships.html>

U. S. Naval Mine Warfare Plan, Fourth Addition

<http://www.exwar.org/mwp/contents.htm>

U. S. Navy Mines

<http://www.chinfo.navy.mil/navpalib/factfile/weapons/wep-mine.html>

APPENDIX A: Coastal Type, Littoral Cells, and Bottom Sediment

In §4 it was shown that mine scour and burial is a two step procedure involving scour processes that work directly on the mine and its close surroundings (nearfield), and more general accretion and erosion processes that act over larger areas (farfield) and result in local changes in sediment level at the mine site. Details of the mechanics of scour and burial in the nearfield are described in §3. Typical farfield processes include the seasonal changes in beach profile associated with high and low waves (Inman, et al., 1993) and the changing rates of the littoral drift of sediment into and out of the mine area in the form of accretion and erosion waves (Figure 4-6).

The global diversity of these near and farfield processes and the types of sediment that they act upon is simplified by ordering the worlds coastal areas into coastal types with similar coastal morphologies, fluid forcing, and kind of sediment. It is found that the morphological coastal classification described here functions well in the ordering process when applied to littoral cells and kinds of sediment found on open coasts. However, *riverine deltaic* and *estuarine* sediments occur in unique environments that may occur along all coasts (e.g., Bennett and Dolan, 2001). Here, these environments are described under marginal sea coasts where their occurrence is most common.

Littoral Cells*

The boundaries of the mine burial process in the farfield always coincide with those of coastal compartments known as *littoral cells*. A littoral cell is a coastal compartment that contains a complete cycle of sedimentation including sources, transport paths, and sinks. The cell boundaries delineate the geographical area within which the budget of sediment is balanced, providing the framework for the quantitative analysis of coastal erosion and accretion. The sediment sources are commonly streams, seacliff erosion, onshore migration of sand banks, and material of biological origin such as shells, coral fragments, and skeletons of small marine organisms. The usual transport path is along the coast by waves and currents (longshore transport, longshore drift, or littoral drift). Cross-shore (on/offshore) paths may include windblown sand, overwash, and ice-push. The sediment sinks

* Parts of this section are excerpted from Inman (in press 2002).

are usually offshore losses at submarine canyons and shoals or onshore dune migration, rollover, and deposition in bays and estuaries (Figure A-1).

The boundary between cells is delineated by a distinct change in the longshore transport rate of sediment. For example, along mountainous coasts with submarine canyons, cell boundaries usually occur at rocky headlands that intercept transport paths. For these coasts, streams and cliff erosion are the sediment sources, the transport path is along the coast and driven by waves and currents, and the sediment sink is generally a submarine canyon adjacent to the rocky headland. In places, waves and currents change locally in response to complex shelf and nearshore bathymetry, giving rise to subcells within littoral cells (e.g., Figure A-2). The nearfield area of the mine burial problem is a control cell within the larger littoral cell.

The longshore dimension of a littoral cell may range from one to hundreds of kilometers whereas the cross-shore dimensions are determined by the landward and seaward extent of the sediment sources and sinks. Littoral cells take a variety of forms depending on the type of coast. Cell forms are distinctive of the following coastal types: collision (mountainous, leading edge), trailing edge, marginal sea, arctic, and coral reef. The first three types are determined by their position on the world's moving plates while the latter two are latitude dependent.

The configuration of littoral cells depends on the magnitude and spatial relations among the sediment sources, transport paths, and sinks. These in turn have been shown to vary systematically with coastal type. Because the large-scale features of a coast are associated with its position relative to the margins of the earth's moving plates, plate tectonics provides a convenient basis for the first-order classification of coasts (Inman and Nordstrom, 1971; Davis, 1996). This classification leads to the definition of three tectonic types of coast: (1) collision coasts that occur on the leading edge of active plate margins where two plates are in collision or impinging on each other, for example, the west coasts of the Americas; (2) trailing-edge coasts that occur on the passive margin of continents and move with the plate, for example, the east coasts of the Americas; and (3) marginal sea coasts that develop along the shores of seas enclosed by continents and island arcs, for example, coasts bordering the Mediterranean Sea and the South and East China Seas.

It is apparent that the morphologic counterparts of collision, trailing-edge, and

marginal sea coasts become, respectively, narrow-shelf mountainous coasts, wide-shelf plains coasts, and wide-shelf hilly coasts. However, some marginal sea coasts such as those bordering the Red Sea, Gulf of California, Sea of Japan and the Sea of Okhotsk are narrow-shelf hilly to mountainous coasts. Also more complete coastal classification includes the latitudinal effects of climate and other coastal forming processes such as ice-push and scour and reef-building organisms. The additional examples of the latter two coastal types described here are (4) arctic form of cryogenic coasts and (5) coral reef form of biogenic coasts. The kinds of source, transport path, and sink commonly associated with littoral cells along various types of coast were summarized in Table A-1.

A.1 Collision coasts *

Collision coasts form at the active margins of the earth's moving plates and are illustrated by the mountainous west coasts of the Americas. These coasts are erosional and characterized by narrow shelves and beaches backed by wave-cut seacliffs. Along these coasts with their precipitous shelves and submarine canyons, as in California, the principal sources of sediment for each littoral cell are the rivers, which periodically supply large quantities of sandy material to the coast. The sand is transported along the coast by waves and currents primarily within the surf zone like a *river of sand* until intercepted by a submarine canyon. The canyon diverts and channels the flow of sand into the adjacent submarine basins and depressions (Figure A-1a).

Wave action contains sand against the coast and, when sediment sources are available, results in accretion of the shorezone. However, cluster storms associated with El Niño-Southern Oscillation events that occurred along the California coast in 1982/83 produced beach disequilibrium by downwelling currents that carried sand onto the shelf (Inman and Masters, 1991). The downwelled sediment is lost to the shorezone when deposited on a steep shelf such as that off Oceanside, California, or it may be returned gradually from a more gently sloping shelf to the shorezone by wave action. The critical value of slope for onshore transport of sand by wave action varies with sand size, depth, and wave climate, but for depths of about 15 to 20 m it is approximately 1.5 percent (1.0 degree).

* Parts of §A.1 - §A.5 are excerpted from Inman (in press 2002).

Sediments

Sediments along collision coasts are generally uniformly distributed because they are the product of a single source, namely the coastal watersheds. They are primarily granitic sediments derived from the hydraulic weathering of coastal mountains. The steep gradients of the coastal drainage basins produce episodic floods that yield large quantities of sediment over a wide range of grain size fractions, including cobbles, gravels, sand, silt, and clay. Flood deposits are rapidly sorted by the high energy waves along collision coasts causing a progressive change of grain size in both the seaward and longshore directions away from river mouths. Additional sediment sources along collision coasts are provided by the wave erosion of sea cliffs and bluffs, most of which are comprised of the alluvial deposits of ancient rivers.

Coarse gravel and cobble material remains localized to the bar-berm section of beach profiles and the back beach areas in the neighborhood of river mouths or eroding sea cliffs. Over time, cobble berms and cobble benches are buried by sand and become the basal conglomerate beneath the bar-berm section of the beach profile. The sand size fraction is well sorted into a narrow size range of mostly fine sand that may extend along the width of the VSW zone. There is a moderate degree of fining between the bar-berm section of the beach profile and closure depth. There is additional fining of the sand with increasing distance along the beach away from the river or bluff sources. This fining is biased toward the downdrift sections of the littoral cell. Seaward of the closure depth the wave stresses on the seabed diminish sufficiently for the silt and clay fractions to settle following initial flood discharge as a turbid plume. This settling process results in a gradation seaward of closure depth from fine sand to silty-sand and eventually to beds of silt on the middle and outer shelf.

A.2 Trailing-edge coasts

Trailing-edge coasts occur along the passive plate margins of continents and include the coasts of India and the east coasts of the Americas. The mid-Atlantic coast of the United States, with its characteristic wide shelf bordered by coastal plains, is a typical trailing-edge coast where the littoral cells begin at headlands or inlets and terminate at embayments and capes (Figures A-1b and A-2). This low-lying barrier island coast has large estuaries occupying drowned river valleys. River sand is trapped in the estuaries and does not usually reach the open coast. For these coasts, the sediment source is from erosion of transgressing beaches and

shelf sediments deposited at a lower stand of the sea, whereas the sinks are sand deposits that tend to close and fill estuaries and form shoals off headlands. Under the influence of a rise in relative sea level, the barriers are actively migrating landward by a rollover process in which the volume of beach face erosion is balanced by rates of overwash and fill from migrating inlets (e.g., Inman and Dolan, 1989).

The Outer Banks of North Carolina, made up of the Hatteras and Ocracoke Littoral Cells, extend for 320 kilometers and are the largest barrier island chain in the world (Figure A-2). The Outer Banks are barrier islands separating Pamlico, Albemarle, and Currituck Sounds from the Atlantic Ocean. These barriers are transgressing landward, with average rates of shoreline recession of 1.4 m/yr between False Cape and Cape Hatteras. Oregon Inlet, the only opening in the nearly 200 km between Cape Henry and Cape Hatteras, is migrating south at an average rate of 23 m/yr and landward at a rate of 5 m/yr. The net southerly longshore transport of sand in the vicinity of Oregon Inlet is between one-half million and one million m³/yr.

Sediments

Sediments along trailing-edge coasts are often the product of multiple sources and frequently show anomalies in their gradation patterns. Typically these sediments are derived from the remnant deposits left behind by a sea that is transgressing over the adjacent low-lying coastal plains, exposing a variety of sedimentary environments (Inman and Dolan, 1989). Sediments north of Long Island on the eastern coast of the U. S. are predominantly glacial in origin. These distinctly different sources cause discontinuities in sediment type and in the tendencies for sediments to be progressively coarser away from river sources. Also, the watersheds of trailing-edge coasts have much smaller gradients than collision coasts and consequently the percentage of sands and coarser material comprising river sediment yield is less. It is common to find muddy deposits in embayments and in the inshore regions around river mouths. These muddy deposits will co-mingle with the offshore deposits that are typically medium to coarse sand. Just offshore of the barrier beaches are complex arrays of large bedforms including migrating sand waves and bars.

It is typical for sediment type to vary radically over short distances (e.g., boulders to clay) in formerly glaciated regions like the New England coast and the

Strait of Juan de Fuca on the Pacific coast. In contrast, bottom sediments typically occur in regular patterns off the coasts of non-glaciated areas, particularly along the Pacific coasts of the Americas (e.g., Salsman and Tolbert, 1962).

A.3 Marginal sea coasts

Marginal sea coasts front on smaller water bodies and are characterized by more limited fetch and reduced wave energy. Accordingly, river deltas are more prominent and are often important sources of sediment within the littoral cell. Elsewhere, barrier island rollover processes are similar to those for trailing edge coasts. Examples of marginal sea coasts include the shores of the Gulf of Mexico with the prominent Mississippi River delta, the seas bordering southeast Asia and China with the Mekong, Huang (Yellow) and Luan river deltas, the Mediterranean Sea coasts with the Ebro, Po, and Nile river deltas, and the Red Sea, Gulf of Aden, Persian Gulf, and Gulf of Oman.

Although the Mediterranean area is associated with plate collision, the sea is marginal due to restricted wave fetch and prominent river deltas. The Nile littoral cell extends 700 km from Alexandria on the Nile Delta to Akziv Submarine Canyon near Akko (Acre), Israel, one of the world's longest littoral cells (Figure A-3). Before construction of the High Aswan Dam, the Nile Delta shoreline was in a fluctuating equilibrium between sediment supplied by the river and the transport along the coast. Now the sediment source is erosion from the delta, particularly the Rosetta promontory, in excess of 10 million m³/yr. The material is carried eastward in part by wave action, but predominantly by currents of the east Mediterranean gyre which sweep across the shallow delta shelf with speeds up to 1 m/s. Divergence of the current downcoast from Rosetta and Burullus promontories forms accretionary blankets of sand that episodically impinge on the shoreline. The sand blankets move progressively downcoast at rates of 0.5 to 1 km/yr in the form of accretion/erosion waves. Along the delta front, coastal currents augmented by waves transport over 10 million m³/yr, while the longshore sand transport by waves near the shore is about 1 million m³/yr (Inman and Jenkins, 1984; Inman et al., 1992).

The Damietta promontory causes the coastal current from the east Mediterranean gyre to separate from the coast and form a large stationary eddy that extends offshore of the promontory, locally interrupting the sediment transport path. The jet of separated flow drives a migrating field of sand ribbons

northeasterly across the delta (Figure A-3). The ribbons arc easterly then southeasterly towards the coast between Port Said and Bardawil Lagoon (Murray et al., 1981). The Damietta sand ribbons form the eastern edge of a subcell within the Nile Littoral Cell. Coastal currents and moving accretion/erosion waves would alternatively cover and expose mines and other solid objects placed along the beaches and nearshore areas of this coast.

Off Bardawil Lagoon, the longshore sand transport is about 500 thousand m³/yr and gradually decreases to the north with the northerly bend in coastline. This divergence in the littoral drift of sand results in the build up of extensive dune fields along the coasts of the delta, Sinai, and Israel. This sediment loss by wind blown sand constitutes a major “dry” sink for sand in the Nile Littoral Cell.

Sediments

Although estuarine and other muddy environments are most common along marginal sea coasts, they may occur along any coast where streams enter large embayments. For example, along trailing-edge coasts muddy sediments predominate at Kings Bay Harbor, Georgia; Charleston Harbor, South Carolina; Pamlico Sound, North Carolina; Chesapeake Bay, etc. Along collision coasts muddy sediments predominate in San Francisco Bay, San Pedro and San Diego Bay California, and Puget Sound, Washington.

In the tidal deltaic marginal seas however, a certain degree of ordering is imparted to the sediment deposition patterns due to sorting action and large bedforms induced by strong tidal currents. In the intertidal areas, mud flats predominate. Further offshore, subtidal sand bars and sand ribbons of homogeneous fine sand may extend downcoast for hundreds of miles as reported along the coast of the East China Sea (NAVO, 1996). The high tidal ranges that occur in these marginal seas will often form large tidal bores that propagate up river inlets, sometimes scouring the local seabed down to the country rock.

A.4 Arctic coasts

Arctic coasts are those near and above the Arctic Circle (66° 34' North Latitude) that border the Arctic Ocean and whose littoral cells have drainage basins in North America, Europe, and Asia. Tectonically, Arctic coasts are of the stable, trailing-edge type, with wide shelves backed by broad coastal plains built from fluvial and cryogenic processes. The coastal plains are permafrost with

tundra and thaw lakes. A series of barrier island chains extends along the Beaufort Sea coast of Alaska (Figure A-4). For these coasts, cryogenic processes such as ice-push and permafrost thaw compete with river runoff, waves, and currents as important sources, transport paths, and sinks for sediment. Ice-push is a general term for the movement of sediment by the thrust of ice against it. Some common features include ice-push ridges and mounds, ice-gouge, ice pile-up, ride-up rubbing, and bulldozing.

During the nine months of winter, arctic coasts are frozen solid and coastal processes are entirely cryogenic. Wind stress and ocean currents buckle and fracture the frozen pack ice into extensive, grounded, nearshore, pressure-ridge systems known as stamukhi zones. The stamukhi zone is a shear zone of ice grounded in 10-25 m depth that molds and moves shelf and barrier island sediment. The keels from the individual pressure ridges groove and rake the bottom, plowing sediment toward the outer barrier islands. Ice-gouge relief up to 2 m occurs across the shelf to depths of about 60 m (Barnes et al., 1984).

Winter is terminated by a very active transitional period of a few days to a few weeks during spring breakup when a combination of factors associated with ice movement, waves, currents, and extensive fluvial runoff all work in concert along the coast. The grounded ridges in the stamukhi zone break up and move, producing ice-push features and vortex scour by currents flowing around the grounded ice, creating an irregular bottom known as ice-wallow topography. Closer to shore, vertical drainage of river flood water and sediment through cracks in the shorefast ice form large strudel-scour craters in the bottom (Reimnitz and Kempema, 1983).

Finally, a short summer period occurs in which the ice pack withdraws from the Beaufort Sea coast forming a 25-km to 50-km wide coastal waterway. Although the summer season is short, storm waves generated in the band of ice-free water transport relatively large volumes of sand, extending barrier islands and eroding deltas and headlands. The summer processes are classical nearshore phenomena driven by waves and currents as shown by the beaches and barrier island chain beginning with Flaxman Island in the vicinity of Prudhoe Bay (Figure A-4). The sediment sources include river deltas, onshore ice-push of sediment, and thaw-erosion of the low-lying permafrost seacliffs. Thaw-erosion rates of the shoreline are typically 5 to 10 m/yr in arctic Russia and, over a 30-year period, averaged 7.5

m/yr for a 23-km coastal segment of Alaska's Beaufort Sea coast midway between Point Barrow and Flaxman Barrier Islands (Reimnitz and Kempema, 1987).

The Flaxman Barrier Island chain extends westward from the delta of the Canning River. It appears to be composed of sand and gravel from the river, supplemented by ice-push sediments from the shelf (Figure A-4). The prevailing easterly waves move sediment westward from one barrier island to the next. The channels between islands are maintained by setdown and setup currents associated with the Coriolis effect on the wind-driven coastal currents. The lagoons behind the barrier islands appear to have evolved in part from collapse and thaw-erosion of tundra lakes (Wiseman et al., 1973; Naidu et al., 1984).

However, even the summer period is punctuated by occasional "Arctic events," including ice-push phenomena and unusually high and low water levels associated with storm surges and with Coriolis setup and setdown, a phenomenon whose intensity increases with latitude. The active summer season ends with the beginning of fall freeze-up.

Sediments

Sediments of cryogenic coasts are transported and deposited by two distinct forcing phenomena, dictated by the freeze-thaw cycle between winter and summer. In winter (75% of the year), freezing locks down the sediments and no redistribution occurs. With the onset of the summer melt, coastal rivers flow at flood intensity and deliver vast amounts of cobbles, gravels, and sands to the arctic beaches, while glacial melt disperses silts and clays over large distances. As the pack ice breaks up early in the summer thaw, ice push will drive shoreward long sections of shore parallel ridges consisting of the silty sand and muddy offshore deposits. Later during the short summer season when the pack ice has moved away from the shore, the littoral transport and deposition redistributes coarse and sandy river deposits in a manner similar to that described for collision coasts. While this occurs, large blocks of pack ice can raft quantities of river deposits to distant locations. Therefore the cryogenic sediment gradations can exhibit discontinuities very similar to those found on trailing-edge coasts and tideless marginal seas.

A.5 Coral reef coasts

Coral reef coasts are a subset of the broader category of biogenous coasts where the source of sediment and/or the sediment retaining mechanism is of biogenous origin as in coral reef, algal reef, oyster reef, and mangrove coasts.

Coral reefs occur as fringing reef, barrier reef, and atolls, and they are common features in tropical waters of all oceans at latitudes within the 20°C isotherm.

Although the concept of the littoral cell applies to all types of coral reef coast, the most characteristic are littoral cells along fringing reef coasts bordering high islands, where both terrigenous and biogenous processes become important. Reefs may be continuous along the coast or occur within embayments. In either case, the configuration of the fringing reef platforms themselves incorporates the nearshore circulation cell into a unique littoral cell (Figure A-5). The circulation of water and sediment is onshore over the reef and through the surge channels, along the beach toward the awas (return channels), and offshore out the awas. An awa is equivalent to a rip channel on the sandy beaches of other coasts (Inman et al., 1963).

Sediments

Along coral reef coasts, the corals, foraminifera, and calcareous algae are the sources of sediment. The overall health of the reef community determines the supply of beach material. Critical growth factors are light, ambient temperature, salinity, and nutrients. Turbidity and excessive nutrients are deleterious to the primary producers of carbonate sediments. On a healthy reef, grazing reef fishes bioerode the coral and calcareous algae and contribute sand to the transport pathway onto the beach.

The beach behind the fringing reef acts as a capacitor, storing sediment transported onshore by the reef-moderated wave climate. It buffers the shoreline from storm waves, and releases sediment to the awas. In turn, the awas direct runoff and turbidity away from the reef flats and out into deep water.

Table A-1. Typical source, transport path, and sink for littoral cells of various coastal types.

Coastal Features	Collision	Trailing-Edge	Marginal Sea		Arctic Form of Cryogenic	Coral Reef Form of Biogenic
Morphology	Narrow-shelf mountainous	Wide-shelf plains	Narrow-shelf mountainous	Wide-shelf hilly	Wide-shelf ^a plains	Coral reef
Latitude/ climate	Temperate & subtropical	Temperate & subtropical	Temperate & subtropical	Temperate & subtropical	Arctic	Tropical
Forcing ^b	Waves: 1-10 kw/m, period 10-18 s	Waves: 1-5 kw/m, period 8-15 s	Fetch-limited waves: 1-2 kw/m, period 3-5 s Tides ^c	Fetch-limited waves: 1-2 kw/m period 4-6 s Tides ^c	Winters ice-push Summer waves: 1-3 kw/m period 6-10 s	Waves 1-10 kw/m, period 8-18 s
Littoral Cell						
Sediment source	Rivers Cliffs Blufflands	Headlands Cliffs Shelves	Rivers Deltas	Rivers Deltas	Shelf Rivers Thaw-erosion	Reef material
Transport path	Longshore (river of sand)	Longshore & rollover ^d (braided river of sand)	Longshore	Longshore & rollover ^d	Ice-push Rafting Longshore	Reef surge channels to beach, longshore to awa
Sink	Submarine canyons Embayments Dune migration	Estuaries Shoals Rollover Dune migration	Various including submarine canyons	Embayments Shoals Rollover Dune migration	Shoals Spit-extension	Awa channels to shelf

a All high latitude coasts appear to be trailing-edge coasts.

b Average incident wave energy-flux per m of coastline (Inman and Brush, 1973).

c Tides may be important along any ocean coast, but are sometimes amplified in marginal seas.

d Rollover processes include overwash and dune migration.

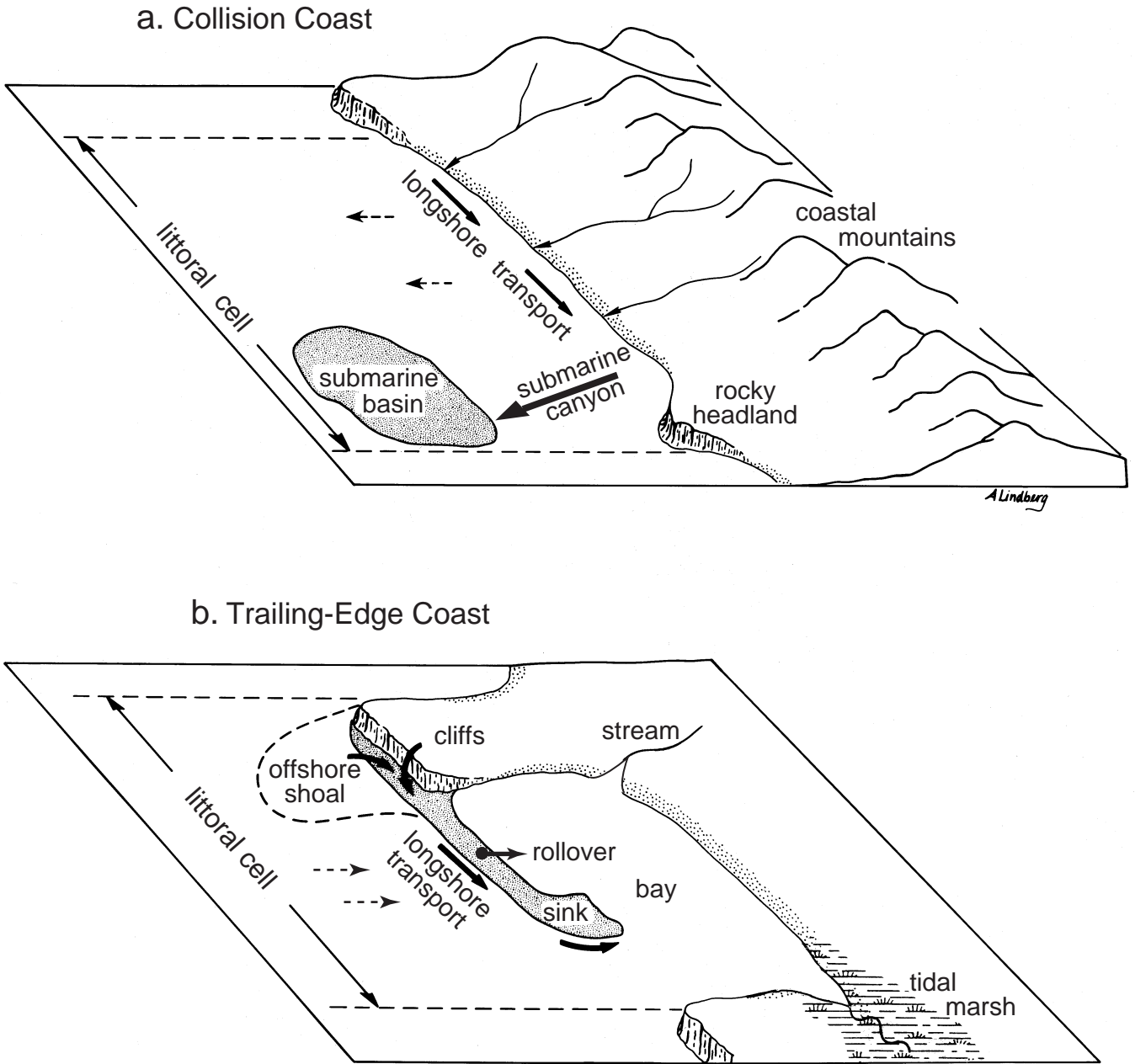

Figure 1. Typical (a) collision and (b) trailing-edge coasts and their littoral cells. Solid arrows show sediment transport paths; broken arrows indicate occasional onshore and offshore transport modes. [after Inman, 1994]

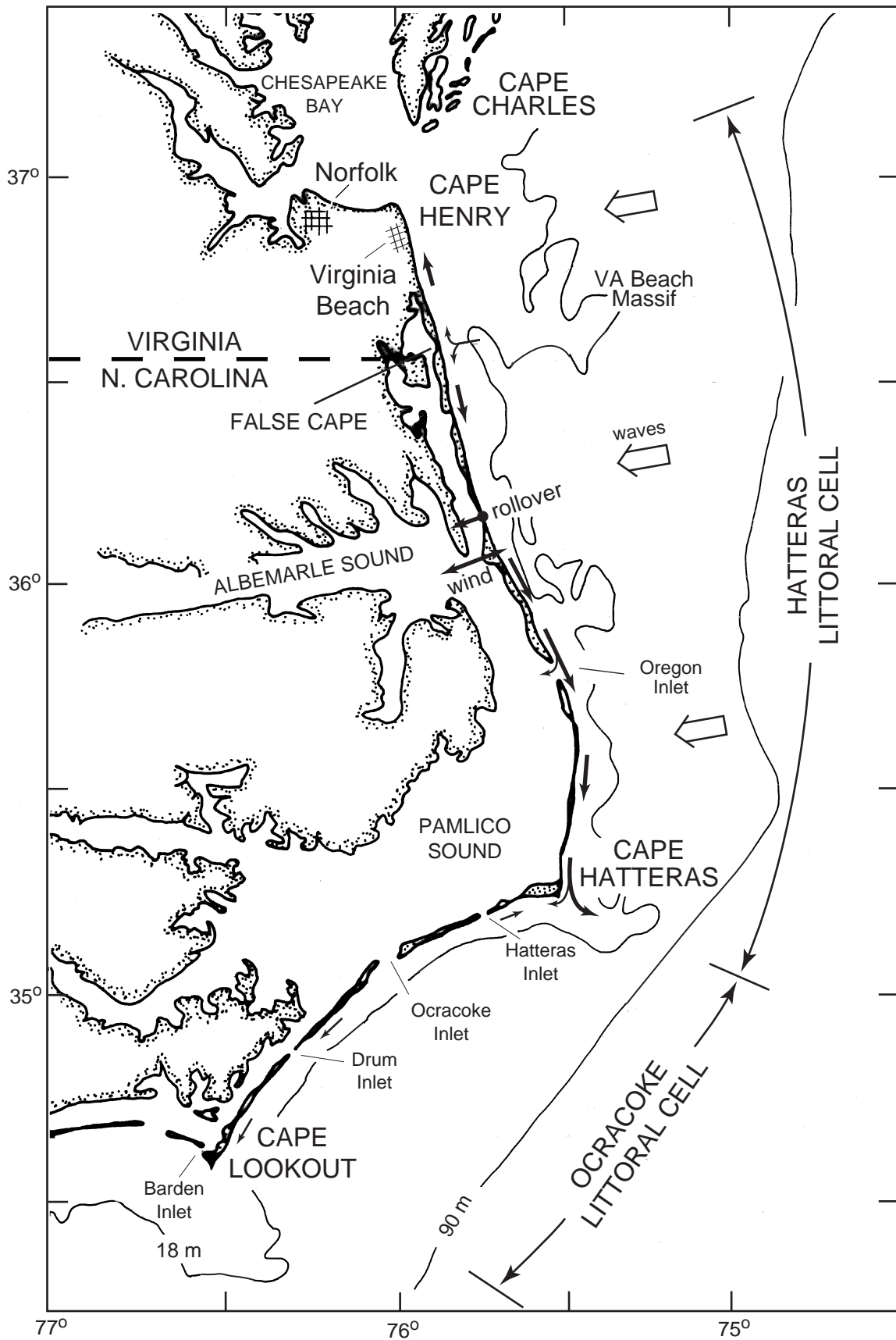

Figure 2. Hatteras and Ocracoke littoral cells along the Outer Banks of North Carolina. [after Inman and Dolan, 1989]

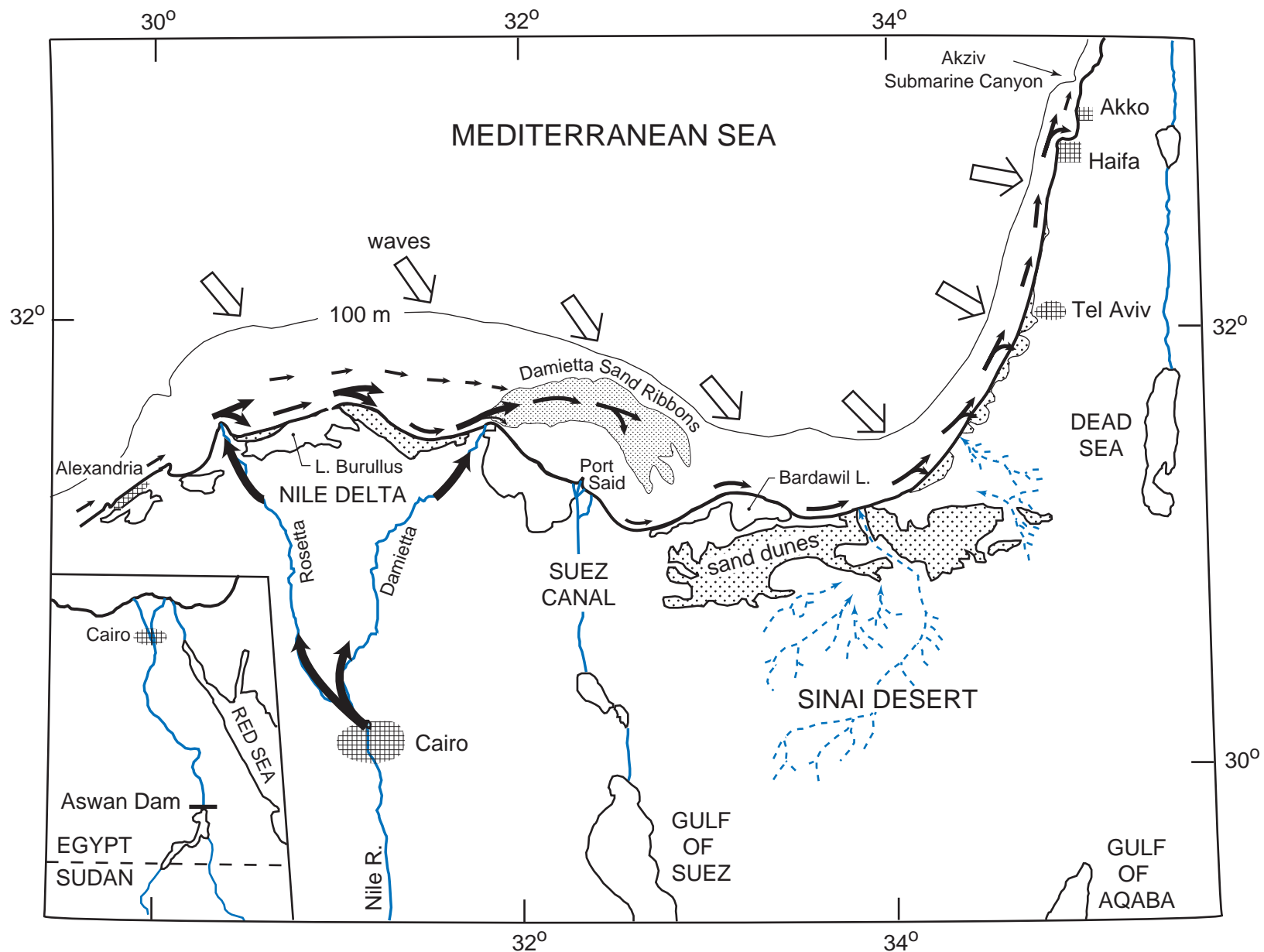

Figure 3. The Nile littoral cell extends along the southeastern Mediterranean coast from Alexandria, Egypt to Akziv Submarine Canyon off Akko, Israel. Sediment transport paths shown by solid arrows. [after Inman and Jenkins, 1984]

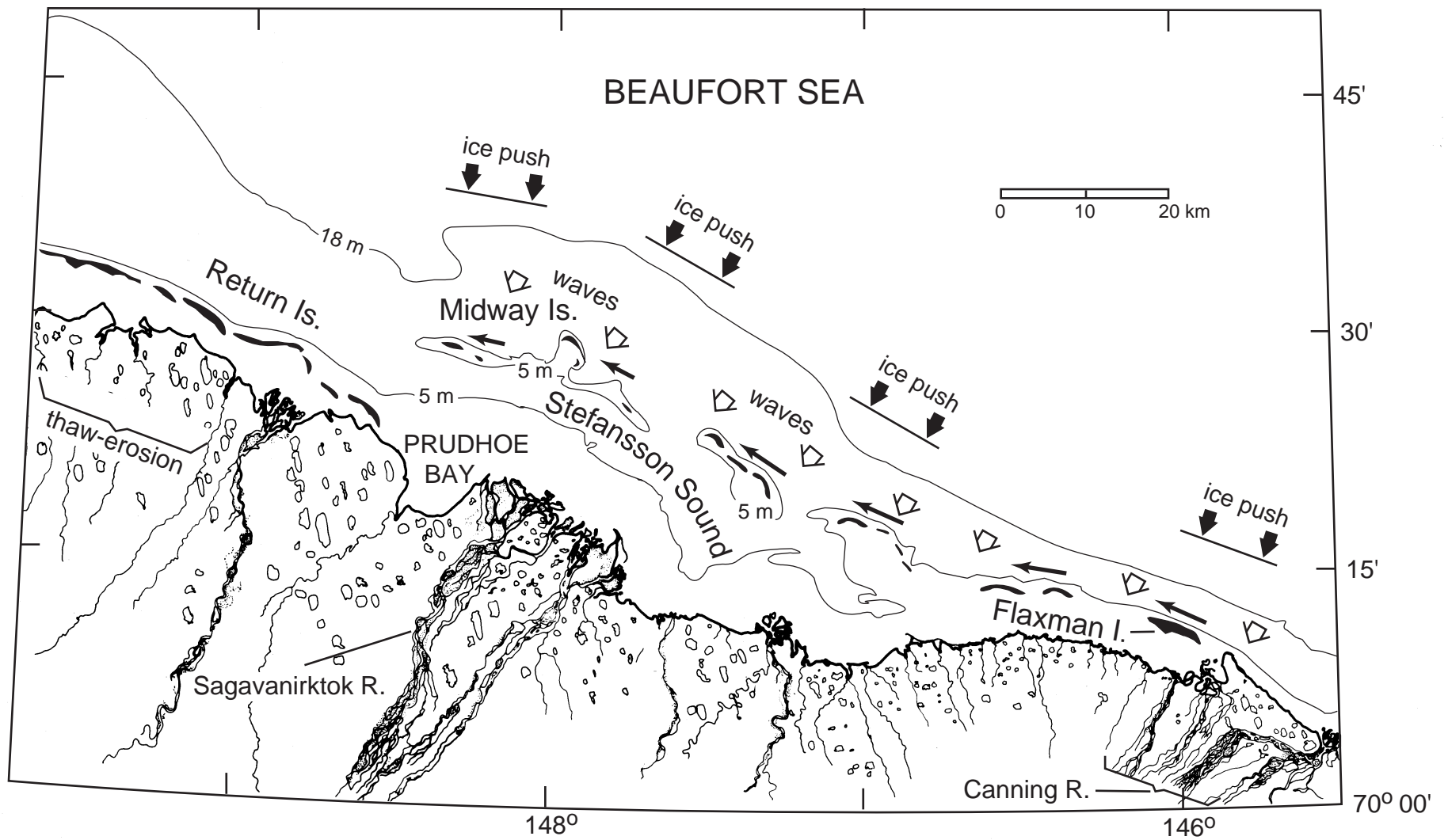

Figure 4. Flaxman Littoral Cell extends 100 km from the mouth of Canning River to the Midway Islands. The chain of barrier islands is enclosed by the 5 m depth contours. Major axes of thaw lakes are oriented normal to the direction of summer winds. [after Inman, 1994]

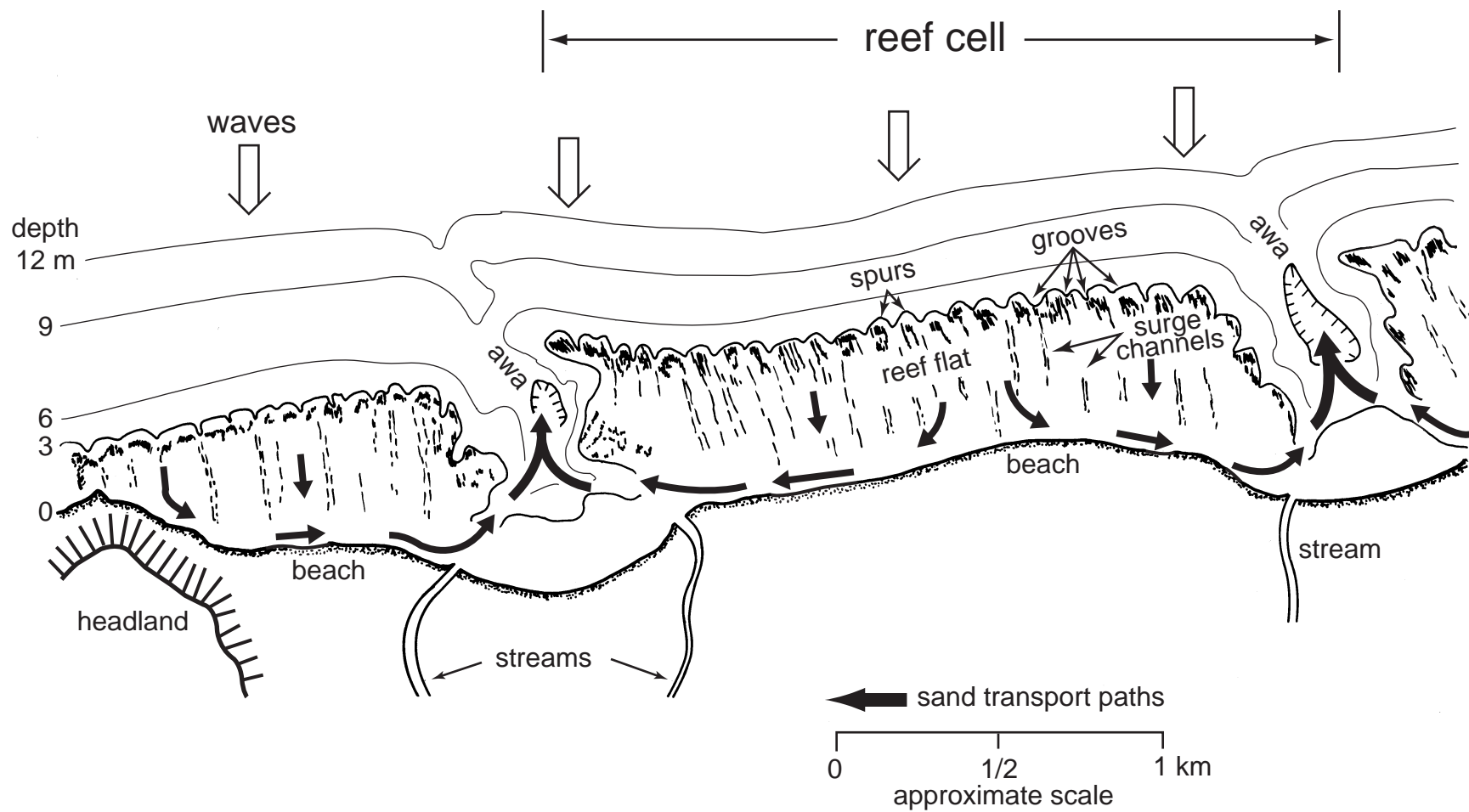

Figure 5. Schematic diagram of littoral cells along a fringing reef coast. [after Inman, 1994]

APPENDIX B: GLOSSARY

[Abbreviations: cf, compare with; syn, synonym; usu, usual or usually]

accretion/erosion wave: a periodic disturbance in the shoreline position caused by pulses of sediment flux to the shore from the land or by longshore variations in littoral drift rates. Accretion/erosion waves are common features near river mouths, coastal landslide sites, tidal inlets, harbor and shoreline structures, or along coasts with periodic variations in wave climate.

acoustic mine: a mine activated by the sound of a ship's propeller and engines.

antenna mine: a contact mine fitted with an antenna that, when touched by a steel ship, sets up galvanic action to fire the mine. The antenna generally takes the form of a special section in the mooring cable and/or a wire suspended above the mine by a float.

antisweeper mine: a mine that is laid or whose mechanism is designed or adjusted with the specific objective of damaging mine countermeasure (MCM) vehicles.

Arctic coasts: coasts facing the Arctic Ocean where winter processes are entirely cryogenic and dominated by *ice-push* phenomena.

autonomous systems: systems employing uninhabited aerial, ground, and underwater vehicles (UAV, UGV, and UUV) and their associated control and operating systems. UUVs are usually guided from a parent ship through a cable attached to the UUV. Autonomous underwater vehicles (AUVs) have no attached cables and are programmed for specific tasks.

awa: channel through a fringing coral reef that carries the seaward return flow (rip current) of a reef circulation cell.

bar-berm: bottom area between the breakpoint-bar and the berm above the beach face; the bottom area under the surf zone [syn: foreshore]

Bayes' theorem: a theorem that gives the conditional probability of a hypothesis, given the original data and some new data.

beach: a zone covered by broken waves and wave deposits extending from the *breakpoint-bar* to the effective limit of attack by storm waves; it consists of the *foreshore* or bar-berm and the *backshore*. [syn: *shore*]

beach face: the sloping section of the *beach* normally exposed to wave swash; it occurs between the *beach* (low-tide) *terrace* and the *berm crest*.

beach field: a minefield in the shallow water approaches to a possible amphibious landing beach.

bedrock: general term for the rock, usu solid, that underlies soil or other unconsolidated, superficial material.

berm: the nearly horizontal part of a *beach* that is adjacent to and above the *beach face*.

berm crest: break in slope between the *beach face* and the *berm*; a position marking the highest *runup* of the *swash*.

biogenic coasts: coasts where organic processes and organic growth dominate the shorezone. Typical examples include: shorezones formed by coral reefs, serpulid reefs, oyster reefs, mangrove plants, and marsh grass. [cf coral reef coast]

bomblet: explosive charge for mine neutralization.

bottom mine: mine of negative buoyancy resting on the bottom of a sea, river, or lake. [syn: *ground mine*]

boundary conditions: requirements set at the boundaries of a system that insure that the flow of mass, momentum, and energy across those boundaries match with the gains or losses of those properties in the environment that surrounds the system. When the system boundaries are deformable, boundary conditions also require an accounting for the change in shape of the boundaries.

breakpoint-bar: a bar that is commonly at or near the breakpoint of the waves.

closed loop sweep: a magnetic sweep in which the sweep current is carried entirely by the insulated electrical conductors and does not depend on seawater to complete the electrical circuit.

closure depth: seaward extent of the changes in depth between winter storm (high wave) and summer (low wave) beach profiles; seaward extent of the *shorerise*.

code: transformation of conceptual model into language used by a computer.

collision coasts: coasts that occur along active continental margins where two plates are in collision or impinging on each other. Morphologically, collision coasts have narrow shelves and are hilly and mountainous. [syn: *leading-edge coasts*]

combination influence mine: a mine whose firing circuit requires actuation by two or more influences, either simultaneously or at a predetermined interval, before the firing circuit is satisfied. In this connection, acoustic systems working on different frequency ranges may be

considered separate influences.

command mine: syn for controlled mine.

computer simulation: illustrations and data produced by programmed with executable code.

conceptual model: an assemblage of processes that reproduce a concept. It includes types of processes ranging from ideas, text, schematic drawings, to block diagrams and how they interact.

contact mine: a mine fired by physical contact between the target and the mine case or its appendages.

control cell: subdivision of a littoral cell used to obtain the local sediment budget at a specific place in the littoral cell. [cf. *littoral cell*]

controlled mine: mine designed to be detonated by command from a remote station syn: command mine.

coral reef coasts: the type of biogenic coast formed by algae and corals; typical of tropical waters surrounding land masses with low sediment yield.

Coriolis effect: the deflection of the trajectory of a moving body or fluid due to the rotation of the earth. The Coriolis effect will deflect trajectories of motion to the right in the northern hemisphere and to the left in the southern hemisphere. The Coriolis effect is zero at the equator and maximum at the poles.

Coriolis setup/setdown: the rise/fall of sea level when the Coriolis force acts along shorelines that are to the right/left of the wind in the northern hemisphere and to the left/right in the southern hemisphere.

creeping mine: a buoyant mine held below the surface by a weight (usually in the form of a chain) and free to creep along the seabed under the influence of stream or current (e.g., into an estuary off which it was laid).

critical slope: the slope at which wave-induced onshore transport of sand ceases. The critical slope varies with depth and wave climate but for depths of about 15-20 m, with moderate wave climate, is about 1.5% (1.0 degree) [Inman, 1994, p. 78].

damage radius: the average distance from a ship within which a mine containing a given weight and type of explosive must detonate if it is to inflict a specified amount of damage to the

ship. The actual distance will not be the same in all directions because the explosive effect of a mine varies with depth and other factors, and the damage likely to be sustained will vary with the relative position of the explosion with respect to the ship target.

dan buoy: a buoy used to mark positions or objects in relatively shallow water. Dan buoys are carried by mine countermeasures ships to support navigation and mark mine fields.

dan runner: a ship guiding on or running a line of dans whether it is sweeping or being used for reference by a minesweeping formation.

dead mine: mine that has been neutralized, sterilized, or rendered safe.

deep minefield: an antisubmarine minefield that is safe for surface ships to cross.

defensive MCM: countermeasures intended to reduce the effect of enemy minelaying once the mines are in the water.

defensive minefield: a minefield laid in international waters or international straits with the declared intention of controlling shipping in the defense of sea communications.

degaussing: the reduction of a ship's magnetic field by the use of electromagnetic coils, permanent magnets, or other means.

Destructor Mine: a mine developed for use in Vietnam against junks and sampans. It uses the Mk 80 series general-purpose low-drag bomb as its warhead. The destructor mine can be used either on land or in water. [cf Quickstrike Mine].

deterministic model: syn for process model.

drifting mine: mine that floats freely on or near the surface of the water. It could resemble timber or some other innocent appearing object. Drifting mines are outlawed by the Hague Convention of 1907 and are no longer used by the U. S. Navy, but are commonly deployed by rogue groups.

electrode sweep: a magnetic cable sweep in which the water forms part of the electric circuit as opposed to a closed-loop sweep where the electric current is carried entirely by electric conductor cables.

estuarine: pertaining to or formed in an estuary.

estuary: the seaward, widened, portion of a river basin where fresh and seawater are in contact and/or where tidal effects are evident.

executable code: a coded computer program that is functional.

expert systems approach and/or model (ESM): a decision making procedure used where the available knowledge consists of a number of incomplete data sets of uncertain bounds and relative importance. The data sets are formed into a set of rules of the if/then (fuzzy logic) type. The rules are assembled into a belief network or network topology. Since the number of possible rules and topologies are large, an expert is required to decide on the most sensible formulation of rules and topology, i.e., the *best belief network*. Expert systems are part of the field of artificial intelligence, and where modeling is involved, are in the category of synoptic (i.e., experience-based) rather than process (deterministic) modeling.

exploratory sweeping: minesweeping accomplished to determine whether mines are present and, if possible, the limits of the mined area. Normally accomplished on a routine basis, it is much less intensive than clearance sweeping.

explosive ordnance disposal (EOD): EOD divers and porpoise are primary means of neutralizing mines detected by minehunting sonars.

explosive train: the circuitry and detonator within the mine case that explodes the warhead upon receiving an activation signal from the target detecting device (TDD).

firing train: syn for explosive train.

floating mine: a mine visible on the surface. Whenever possible, it should be more exactly defined by the terms *watching mine* or *free mine*.

forcing function: time series of forces that cause the movement of water and sediment within the littoral cell. Common examples are wind, wave, and tidal forces in addition to precipitation and streamflow.

free mine: a moored mine whose mooring has parted or been cut. Also known as a floater or drifter.

Froude number: dimensionless rates u/\sqrt{gh} where u is the water velocity, \sqrt{gh} is the shallow water wave speed, g is the acceleration of gravity and h is the water depth.

fuzzy logic: rules of the “if/then” type where a probability of occurrence is assigned to the “if statement” of each rule, resulting in a degree of uncertainty with the “then” outcome of the rule.

Global Positioning System (GPS): a worldwide satellite-based navigation system capable of providing precise navigation data adequate for AMCM and MCM forces.

going high order: neutralizing a mine by causing it to explode.

going low order: neutralizing a mine by disabling the firing device.

ground mine: syn for bottom mine.

Hague Convention (1907): a series of rules governing the use of sea mines was reached at the Hague Conferences in the early 1900's. These rules represent the only international law or agreement that covers naval mines and mining.

holiday: an unswept, unsearched, or unclear gap left unintentionally during sweeping or minehunting, due to errors in navigation, stationkeeping, dan-laying, breakdowns, or other causes.

homing mine: a mine with propulsion equipment that homes to a target. The mine normally rests on the seabed and once activated by the target, becomes a target-seeking propelled mine. syn: *propelled mine*.

horn: a projection from the mine case of a contact mine that, when broken or bent by contact, causes the mine to fire.

hydrostatic arming device: a device that withholds the detonator from the explosive components until the mine has reached a preselected depth.

ice-push: a general term for the movement of sediment by the thrust of ice against it. Some common features include ice-push ridges and mounds, ice-gouge, ice pile-up, ride-up, rubbling, and bulldozing.

impact burial: bottom penetration by a mine or other object that has fallen through the water column and impacted the seabed.

influence mine: mine that is detonated by detecting a magnetic, acoustic or pressure signal emanating from a target.

influence sweep: a sweep designed to produce an influence similar to that of a ship and, thus, to activate mines.

initial path sweeping: sweeping to clear a path through a mined area to reduce danger to the following sweepers. It may be accomplished by helicopters, drones, or small craft.

kite: NATO term for the depressor in a mechanical sweep. A towed planing device that causes the inboard end of the sweep to reach a determined depth.

limpet mine: an explosive charge with a timer, designed to be attached to the hull of a ship.

littoral cell: a coastal compartment that contains a complete cycle of sedimentation including sources, transport paths, and sinks.

magnetic mine: mine activated by the magnetic properties of the target.

manual mine: a bottom or moored mine that is detonated by an observer on the shore through a cable attached to the mine (Duncan, 1962).

marginal sea coasts: coasts that develop along the shores of seas enclosed by continents, peninsulas and islands. Typically they are hilly, have wide shelves, limited wave fetch, and large deltas.

mechanical sweep: any sweep used with the objective of physically contacting the mine or its appendages.

mine countermeasures (MCM): this term includes all measures for countering a mine, including the prevention of enemy minelaying.

minefield: a number of mines laid, or declared to be laid, in a land, marine or amphibious landing area for any purpose.

mine laying: the arming and placement of mines in the ocean.

mine planting: usu. precision mine laying. [also syn: mine laying]

minesweeping: clearing mines by minesweepers using mechanical or explosive gear, which physically removes or destroys the mine, or by producing in the area the influence field necessary to activate them. Minesweeping affects all mines covered by the sweep employed, not just one at a time.

mine warfare: the field of designing, producing, and laying mines and parallel effort of designing, producing, and operating all forms of mine countermeasures to combat the enemy's mining campaign.

moored mine: buoyant mine retained in position by cable attached to an anchor on the sea bottom. [syn: *volume mine*]

munitions and explosives of concern (MEC): syn for unexploded ordnance (UXO).

neutralization: a mine is neutralized when it has been rendered, by external means, incapable of firing on passage of a ship or sweep. The explosive may remain dangerous to striking or severe handling, and the mine case may remain virtually intact.

orbital diameter (d_o): the back and forth excursion distance of a particle of water near the bottom due to surface waves.

otter: a towed hydrodynamic planing device that displaces itself sideways when towed through the water.

pattern model: syn for synoptic model.

phi (ϕ): a logarithmic scale for sediment size, $\phi = -\log_2 D$, where D is the grain diameter in mm.

pressure mine: mine activated by the change in water pressure caused by the passage of a ship.

process model: computer model coded to employ the mechanics of the process (e.g., equations of motion, continuity, etc.) to compute an end product such as the littoral drift of sand. [syn: deterministic model]

process: the physics that governs cause and effect relationships observed in nature. The physics almost always represent specific formulations of Newton's Laws of Motion, the Laws of Thermodynamics, and the Principles of Mass Conservation (continuity).

proud: a state of mine exposure where the mine rests upright on the seabed with no burial. (after the nautical term, "proud on the horizon," in reference to a ship in bold outline with no curvature effect on its silhouette).

Quickstrike Mine: an aircraft-delivered family of bottom mines that are an improved follow-on to the Destructor MARK 36 and MARK 40.

remotely operated vehicle (ROV): syn for uninhabited underwater vehicle (UUV).
[cf *autonomous systems*]

response: the reaction of a system to a given action on that system, typically in accordance with Newton's 3rd Law of Motion. In *process modeling* the response is the system's reaction to the *forcing functions* that act on the system through *boundary conditions*.

riverine: pertaining to or formed by a river, or situated along the banks of a river; eg., a riverine harbor.

sapper: a person employed in mine laying.

sea mine: mine used in naval warfare and emplaced in deep or shallow waters, coastal areas, harbor entrances, rivers, canals, and estuaries. In terms of use, sea mines include *bottom*, *moored* and *drifting* mines. [syn: *naval mine*]

self-destruct circuit: a timing circuit in a mine that causes the mine to detonate after a set period.

shakedown: subsidence and burial of a mine associated with rocking motion that is thought to cause (?) liquifaction of granular bed material.

shallow water (SW): tactical term for the nearshore area between 12 m and 61 m depths. [cf, surf, very shallow water]

shoreface: a zone between the shore and the storm wave depth, usu about 10 m. [cf shorerise]

shorerise: the transition between the *continental shelf* and the *beach*, marked by the increase in slope leading from the gently sloping shelf up to the beach proper. It extends from the *closure depth* to the *breakpoint-bar*. [cf. *shoreface*]

stationkeeping time: time that a demolition charge remains in effective range of the targeted mine.

strudel-scour: craters scoured on the sea floor by vertical drainage through cracks in the shorefast ice that occur during the yearly spring flooding over fast ice surrounding Arctic deltas. Craters may be as much as 20 m wide and 4 m deep. [Reimnitz et al., 1974]

subsequent burial: scour and burial of an object resting on the seabed, subsequent to impact burial.

surf: wave activity in the surf zone. As a tactical terminology, the area between the high tide line and 3 m depth (cf shallow water, very shallow water).

surf zone: the area traversed by breaking waves and their bores and swash; it extends from the wave breakpoint to the maximum runup of the swash. [cf bar-berm]

synoptic model: computer model coded to look for trends and patterns within vast amounts of data and then associate these patterns with future trends to make forecasts. [syn: pattern model]

target detecting device (TDD): the device and/or circuitry attached to or within a mine case that detects the presence of a target and activates the firing train that detonates the mine. *Contact mines* have TDDs that activate upon physical contact with a target, while *influence mines* respond to acoustic, magnetic, or pressure signals emanating from a target.

trailing-edge coasts: coasts that occur on the trailing-edge of a land mass that moves with the plate. Typically these are wide-shelf plains coasts as along the Atlantic coasts of North and South America.

unexploded ordnance (UXO): munitions and explosives of various kinds that require sweeping measures before areas can be traversed in safety. [syn: munitions and explosives of concern, MEC]

uninhabited underwater vehicle (UUV): syn for *remotely operated vehicle (ROV)*, cf *autonomous systems*.

very shallow water (VSW): tactical term for the nearshore area between 3 m and 12 m depths. [cf, surf, shallow water]

volume mine: syn for moored mine.

vortex: a collection of fluid particles that rotate around a common axis. Typical examples are tornados, hurricanes, and cyclones in the atmosphere, and current eddies and wake eddies in water.

vortex filament: a vortex with infinitesimally small rotational diameter (core). Vortex filaments have simple mathematical formulations that can be superimposed in various arrangements to represent complex vortex structures.

warhead: explosive package within the mine case.

watching mine: a mine secured to its mooring but showing on the surface, possibly only in certain tidal conditions.