

# Lawrence Berkeley National Laboratory

## Recent Work

### Title

VISUALIZATION OF GAMMA-RAY-EMITTING ISOTOPES IN THE HUMAN BODY

### Permalink

<https://escholarship.org/uc/item/7v18m4rc>

### Authors

Anger, H.O.  
Mortimer, R.K.  
Tobias, C.A.

### Publication Date

1955-03-01

UNIVERSITY OF  
CALIFORNIA

*Radiation  
Laboratory*

TWO-WEEK LOAN COPY

*This is a Library Circulating Copy  
which may be borrowed for two weeks.  
For a personal retention copy, call  
Tech. Info. Division, Ext. 5545*

BERKELEY, CALIFORNIA

## **DISCLAIMER**

This document was prepared as an account of work sponsored by the United States Government. While this document is believed to contain correct information, neither the United States Government nor any agency thereof, nor the Regents of the University of California, nor any of their employees, makes any warranty, express or implied, or assumes any legal responsibility for the accuracy, completeness, or usefulness of any information, apparatus, product, or process disclosed, or represents that its use would not infringe privately owned rights. Reference herein to any specific commercial product, process, or service by its trade name, trademark, manufacturer, or otherwise, does not necessarily constitute or imply its endorsement, recommendation, or favoring by the United States Government or any agency thereof, or the Regents of the University of California. The views and opinions of authors expressed herein do not necessarily state or reflect those of the United States Government or any agency thereof or the Regents of the University of California.

May, 1955

UCRL-

## VISUALIZATION OF GAMMA-RAY-EMITTING ISOTOPES IN THE HUMAN BODY

By

H. O. Anger, R. K. Mortimer, and C. A. Tobias

Donner Laboratory of Biophysics and Medical Physics  
and Radiation Laboratory  
University of California, Berkeley, California

When a compound labeled with a radioactive isotope is administered to a human or animal, the material is distributed to various organs and sites in the subject according to the material administered and the metabolic state of the subject. It would be useful to be able to visualize on a map or photograph the distribution of the active isotope. This can be done for gamma-ray-emitting isotopes by means of the instruments described here.

### THE GAMMA-RAY PINHOLE CAMERA

The gamma-ray pinhole camera is an instrument that provides a picture of the distribution of radioactivity. As described by Copeland and Benjamin,<sup>1)</sup> it consists essentially of a lead shield, with a small aperture through which gamma rays can pass, and a gamma-ray-sensitive material such as a radiographic film located a few inches behind the aperture. Some of the gamma rays from the subject pass through the aperture and form an image of the gamma-ray-emitting areas of the subject behind the pinhole. The image can be made visible by exposing and developing the radiographic film.

The very low sensitivity of this instrument can be improved by replacing the radiographic film with a suitable phosphor and a light-sensitive photographic plate as described by Anger.<sup>2)</sup> The phosphor converts the gamma rays to light and the resulting light exposes the photographic plate. A suitable material for this purpose is thallium-activated sodium iodide. When gamma rays impinge on this phosphor, recoil electrons are produced, which in turn produce scintillations of light. The high density of sodium iodide and the large thickness that can be used result in more efficient blackening of the photographic plate.

A working model of a gamma-ray pinhole camera using this principle is shown in Fig. 1. Some of the gamma rays from the subject below the camera travel through the pinhole and reach the large flat sodium iodide crystal at the top. The gamma rays cause the crystal to emit light, some of which reaches and exposes a photographic plate placed just above the crystal. The spreading

of the light before it reaches the photographic plate and the consequent loss of definition are limited by the inverse-square law and by total reflection at the boundary between the crystal enclosure and the photographic plate.

Because thick transparent intensifying screens are used, it is not possible to obtain good definition, but this can be tolerated in a gamma-ray pinhole camera because the definition of the camera is inherently low. Even if the pinhole is made very small some gamma rays travel through the lead adjacent to the pinhole, and the effective size of the aperture is still fairly large.

The use of this technique allows the sensitivity of the camera assembly to be about 20 times as great as it would be if Kodak No-Screen X-ray film were used with the usual lead foil intensifying screens. Thus it is possible to obtain a faint image of a source containing 1 millicurie of  $I^{131}$  per square centimeter with an exposure time of 1 hour when the pinhole size is 1/8 inch, the thickness of the thallium-activated sodium iodide crystal used as the intensifying screen is 5/16 inch, and Kodak type 103a-0 spectrographic plates are used as the light-sensitive material.

Although this sensitivity is quite low, it has been possible to obtain an in-vivo gamma-ray autoradiograph of a metastatic thyroid tumor containing 20 millicuries of  $I^{131}$ . It was possible to take this picture only because the patient required a therapeutic dose of  $I^{131}$ . The gamma-ray autoradiograph and a corresponding X-ray radiograph are shown in Fig. 2. The tumor was located at the patient's elbow. The radioactive iodine is shown to be taken up in two main areas in the tumor.

#### THE PINHOLE CAMERA AND IMAGE AMPLIFIER

The sensitivity of the gamma-ray pinhole camera can be increased by use of an image-amplifier tube similar to those used for the intensification of fluoroscopic X-ray images. A drawing of the instrument as described by Mortimer, Anger, and Tobias<sup>3)</sup> is shown in Fig. 2. The subject is at the left of the camera. Gamma rays from the subject pass through the pinhole and form an image of the gamma-ray-emitting areas of the subject on the mosaic of fluorescent crystals. Each crystal is surrounded with a reflector which directs the light produced in the crystal to the photocathode of the image-amplifier tube. Light falling on the photocathode causes electrons to be emitted. The electrons are accelerated by a 25-kv potential and are focused by an electron lens on a small zinc sulphide-zinc selenide screen at the other end of the tube. The image formed here can be viewed through a magnifying lens system or it can be photographed.

The tube increases the light intensity by a factor of 600. The gain is due both to the acceleration of the photoelectrons by the 25-kv potential and to the reduction of the image size by the electron lens. The size of the image on the fluorescent screen is 1/9 the size of the photocathode, thus gaining by a factor of 81 in brightness because of the reduction in size of the electron image. With this apparatus it is possible, after dark-adapting the eyes, to view on the screen sources of radioactivity as small as about 200 microcuries per square centimeter.

The useful gain of the image-amplifier tube--and therefore the sensitivity of the system--is limited by the background glow of the viewing screen when no light falls on the photocathode. This glow is caused by thermal and field emission of electrons from the photocathode surface, and also by electrons knocked out by cesium ions migrating to the photocathode. The background due to the latter cause can be reduced by a factor of 5 by cooling the tube to 0°C.

However, even with the image-amplifier tube cooled to 0°C and with the image photographically integrated, the sensitivity is about 10 microcuries per square centimeter with a 30-minute exposure time. This sensitivity is great enough for some in vivo tracer experiments. Greater sensitivity would increase the usefulness of the instrument considerably.

A photograph of an image obtained on the screen of the image-amplifier tube from a radioactive source is shown in Fig. 3. The source was a V-shaped groove in a lucite block filled with  $I^{131}$  solution. The activity of the source was 4 mc/cm<sup>2</sup>. The diameter of the pinhole aperture was 3 millimeters and the exposure time to obtain this picture was 8 minutes with Super XX film at f/6.

The sensitivity would be considerably greater if the photographic film could be placed in contact with the fluorescent screen. In the tube used for these tests the screen was located at an appreciable distance inside the envelope, thus making it necessary to photograph it with a camera. This caused a considerable loss in light and sensitivity. The ultimate in sensitivity would be reached if each scintillation produced in one of the fluorescent crystals by a gamma ray were amplified so as to be visible to the eye and so that it would appear as a dot if a photograph were taken. This sensitivity might be achieved if a two- or three-stage image amplifier were used. Further work along these lines is indicated.

## THE MULTIPLE-SCINTILLATION COUNTER SCANNER

Another method of determining the distribution of radioactivity in a subject is to scan over the subject with one or more directional gamma-ray counters and indicate by some means the relative counting rate over the area scanned. Scanners employing a single scintillation counter have been described by Cassen<sup>4)</sup> and Mayneord<sup>5)</sup>.

If more than one scintillation counter is used, the area that can be covered in a given time is proportionately increased. A scanner employing 10 scintillation counters is shown in Fig. 4. This instrument can produce a picture of the distribution of radioactivity in the whole body of a human subject in about 45 minutes and can detect less than 1/4 microcurie per square centimeter. It is a modification of a 10-counter scanner described previously.<sup>6)</sup>

The instrument consists essentially of 10 scintillation counters in a lead shield, 10 glow lamps connected to the counters through amplifiers so that a count from each of the counters produces a flash of light in the corresponding glow lamp, a mirror system, and a Polaroid Land camera that records the flashes from the glow lamps as spots on a photographic film.

Each scintillation counter consists of an end-window photomultiplier tube 1.5 inches in diameter which is coupled optically to a thallium-activated sodium

iodide crystal 0.5 inch in diameter by 1 inch long. The counters are positioned along two straight parallel lines as shown in Fig. 4. Below each counter is an aperture in the lead shield which points straight down. Various sizes of apertures are used, depending on the sensitivity and definition required. To scan an area for gamma-emitting isotopes, the counters are moved slowly by means of a motor in a direction perpendicular to the two lines along which the counters are located. An area 8 inches wide and any desired length (usually 24 inches) is covered by each scan.

When a person is to be scanned, the subject lies on a table and the counters move over him from left to right for a distance of 24 inches and then return to the starting point. To scan the whole subject, about 10 or 11 scans are taken. The first scan covers the subject's head; then the table on which the patient lies is moved so that the second scan covers his neck; the third scan covers his upper chest; and so on. Four minutes are required for each scan and 45 minutes are required to scan in this manner from head to toe. The resulting separate pictures are joined together to form a composite head-to-toe picture.

The distribution of activity is recorded by means of the 10 glow lamps, the mirror system, and the camera. The glow lamps and 10-channel amplifier are connected so that each gamma ray detected by any of the scintillation counters produces a flash of light in the corresponding glow lamp. For instance, gamma rays detected by the first counter produce flashes in the first glow lamp, and so on. The glow lamps and mirror system are contained in a dark box, and are so arranged that while the counters are moving over the subject, the rotating mirror in front of the camera lens causes the glow lamps to appear to move in synchronism before the camera. During each scanning period a time exposure of the glow lamps is taken with the Polaroid Land camera. This camera develops and delivers a finished print one minute after each scan is taken.

Each flash of a glow lamp appears as a dot on the photograph. Where the activity is greatest in the subject, the greatest number of dots appears on the corresponding part of the photograph. Therefore, a map of the distribution of activity is obtained with concentrations of dots indicating where the activity is greatest. The natural background due to cosmic rays and stray radioactivity appears as a few dots randomly distributed over the print.

A single scan results in a picture with 10 rows of dots having what might be called 10-line definition. In practice, increased definition is obtained by interlacing scans in the following way. The counters first move from left to right over the subject. Then the shield is moved, in a direction perpendicular to the original direction of motion, just one-half the distance between the apertures. Then the counters scan from right to left over the same area of the subject. At the same time the images from the glow lamps are interlaced optically by an adjustment in the mirror system. The result is a scan with 20-line definition. This is the type of scan usually taken on all large subjects.

Test images obtained with the scanner are shown in Fig. 5. The scans were taken of a radioactive test pattern made by filling an X-shaped groove in a lucite block with  $I^{131}$  solution. The test pattern contained a total of 10 microcuries of  $I^{131}$  or about 0.25 microcurie per square centimeter. It was located one inch from the scanner shield, and apertures  $3/8$  inch in diameter were used. The thickness of the shield was 1 inch. A 10-line image made by a single scan is shown at (A), a 20-line interlaced image at (B), and a 40-line interlaced image

at (C). The increase in definition obtained by interlacing is clearly demonstrated.

The same radioactive test pattern was scanned when it was located 0.25 inch away from the shield in (D) and 3 inches away in (E). These pictures show the decrease in definition obtained as the distance to the radioactive source is increased.

The result of increasing the scanning time without changing the interlacing is shown by comparing (E), which is a regular 4-minute, 20-line interlaced scan, with (F), which was made by recording two 4-minute scans over the same area on the same print. The repeated scan gives a more definite image because of the larger number of counts recorded.

The scanner is sufficiently sensitive that it can detect one microcurie of  $I^{131}$  if the activity is concentrated in an area 1 inch or less in diameter. This sensitivity is for a 20-line interlaced scan with apertures  $3/8$  inch in diameter and with material equivalent to 2 inches of tissue between the scanner and the radioactive source. Slightly weaker sources can be detected with no loss in definition by taking repeated scans of the same area, each scan being recorded on the same print.

Some examples of in vivo gamma-ray pictures are shown in Fig. 6. The four pictures show the liver and spleen of human subjects who have received an intravenous injection of 50 to 100 microcuries of colloidal gold-198. Nearly all of this material is taken up by the liver and spleen. In each case, the liver is at the left of the picture and the spleen, sometimes considerably enlarged over the normal size, is shown more faintly on the right. The radioactivity present in these organs was as little as 0.1 microcurie per square centimeter of area as seen by the scanner. Each picture covers an area 16 by 24 inches and the total scanning time for each was 16 minutes. From these pictures the size and shape of the organs can be estimated. Stirreft, Yuhl, and Cassen<sup>7)</sup> have used similar surveys of the liver to detect tumors large enough to displace an appreciable amount of liver tissue.

An example of head-to-toe scanning of a thyroid carcinoma patient is shown in Fig. 7. The patient's thyroid had been removed 2 years previously and he had a large metastatic lesion near his left elbow for which he had been given therapeutic doses of  $I^{131}$ . No other lesions were evident before the scanner pictures were taken. The patient was given an oral dose of 5 millicuries of  $I^{131}$  and a series of three head-to-toe scanner pictures was taken. The first was taken 1 hour after the dose was administered, and it shows that the  $I^{131}$  was distributed throughout his body. The second was taken 48 hours later and shows some points of concentration of iodine, but they are inconclusive except for the elbow because of the high body background. An outline of the patient's body is still visible because of the slow disappearance of iodine in this patient from the blood and intercellular space. The third picture was taken at 96 hours and shows 6 points where iodine was taken up in significant amounts. They are at the sternum, the right pelvic region, the lower right chest, the left arm near the shoulder, the jaw region near the front teeth, and the left elbow. The locations are indicated on the outline drawing at the right.

X-ray radiographs were taken of the points where iodine was taken up after they were found with the scanner. On the sternum near the third rib a



calcified area was found, and in the right pelvic region a small spur of bone was found on the ilium. Neither of these artifacts as seen on an X-ray radiograph was abnormal enough to be considered as the site of a metastatic lesion on the basis of the X-ray evidence alone. However, on the basis of the findings with the scanner, all six points, with the possible exception of the jaw region, can be identified with relative certainty as the site of a metastatic thyroid lesion.

The use of gamma-ray scanning in combination with X-ray radiographs provides maximum information in locating thyroid lesions, since the X-ray radiograph, if the lesion is visible on it, shows with greater accuracy where the lesion is located, and also indicates the depth. However, thyroid lesions that are not visible by means of X-ray radiographs can be detected and located by means of gamma-ray scanning.

### CONCLUSION

The pinhole camera with an improved image amplifier and the scintillation-counter scanner both show promise of increasing usefulness in tracer research and in diagnosis involving gamma-ray-emitting radioisotopes. The scanner is useful at the present time for locating thyroid lesions and for outlining the liver and spleen. Other uses will be found as new tracer compounds and techniques are developed.

### REFERENCES

- 1) Copeland, D. E., and E. W. Benjamin, Pinhole Camera for Gamma-Ray Sources, *Nucleonics* 5, No. 2:44 (1949)
- 2) Anger, H. O., Use of a Gamma-Ray Pinhole Camera for in-vivo Studies, *Nature* 170:200 (1952)
- 3) Mortimer, R. K., H. O. Anger, and C. A. Tobias, The Gamma-Ray Pinhole Camera and Image Amplifier, University of California Radiation Laboratory Report No. UCRL-2524 (1954)
- 4) Cassen, B., L. Curtis, C. Reed, and R. Libby, Instrumentation for  $I^{131}$  Use in Medical Studies, *Nucleonics* 9, No. 2:46 (1951)
- 5) Mayneord, W. V., R. C. Turner, S. P. Newberry, and H. J. Hodt, A Method of Making Visible the Distribution of Activity in a Source of Ionizing Radiation, *Nature* 168:762 (1951)
- 6) Anger, H. O., A Multiple Scintillation Counter in-vivo Scanner, *Am. J. Roentgenol. Rad. Therapy and Nuclear Med.* 70, No. 4:605-612 (1953)
- 7) Stirret, L. A., E. T. Yuhl, B. Cassen, Clinical Applications of Hepatic Radioactivity Surveys, *Am. J. Gastroenterology* 21, No. 4:310 (1954)

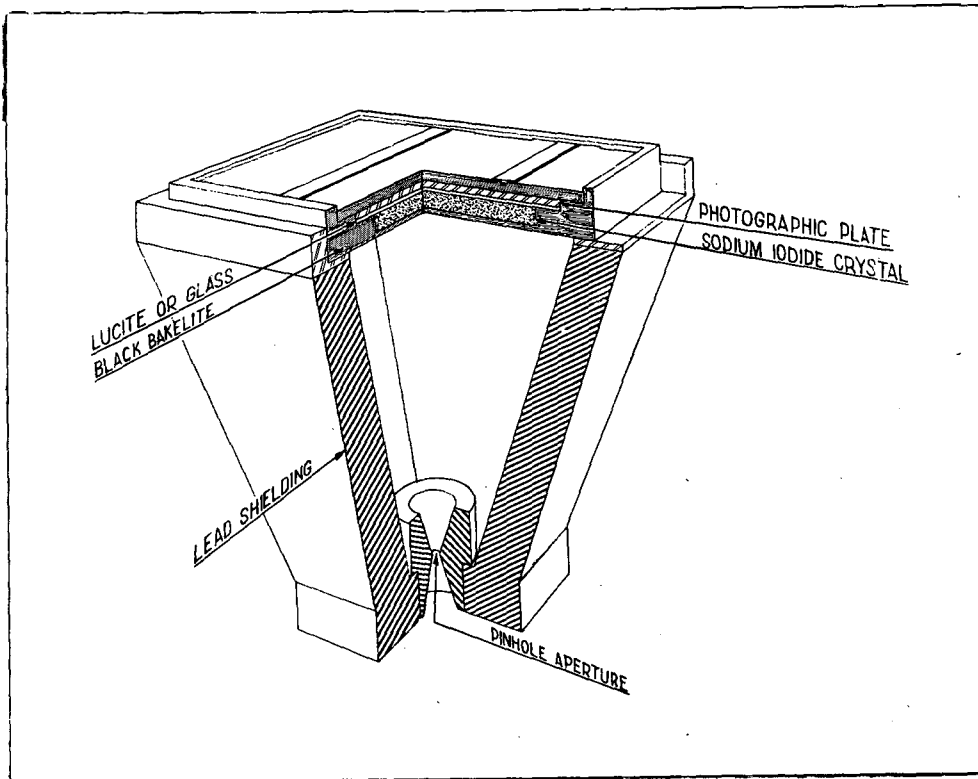

Fig. 1

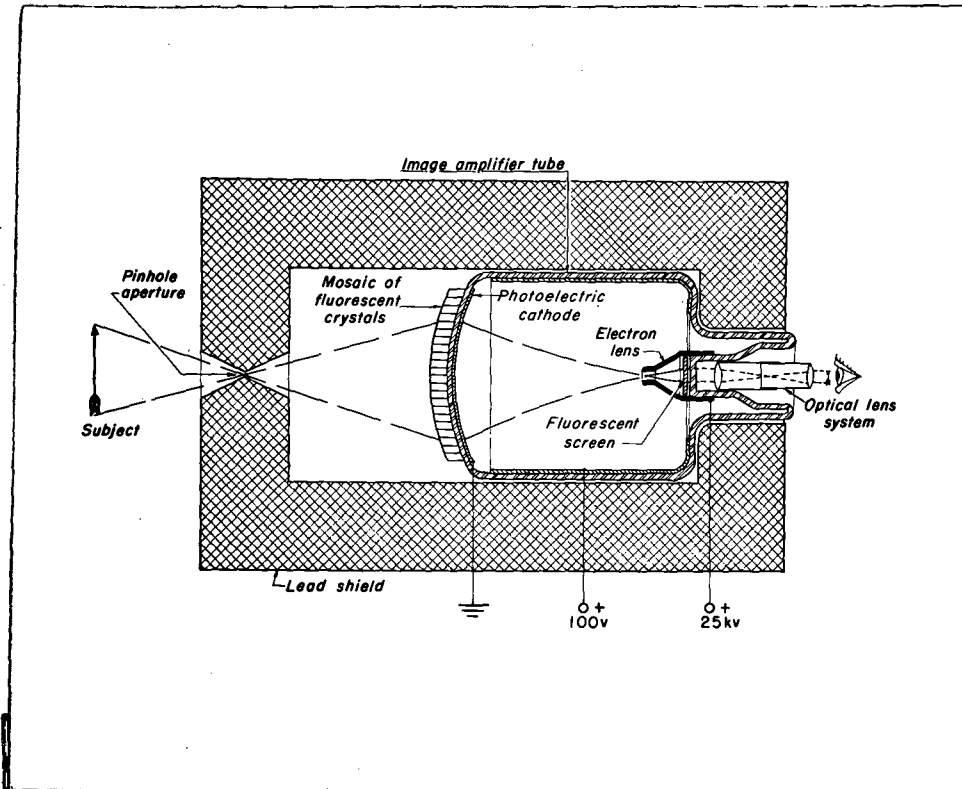

Fig. 2



Fig. 3

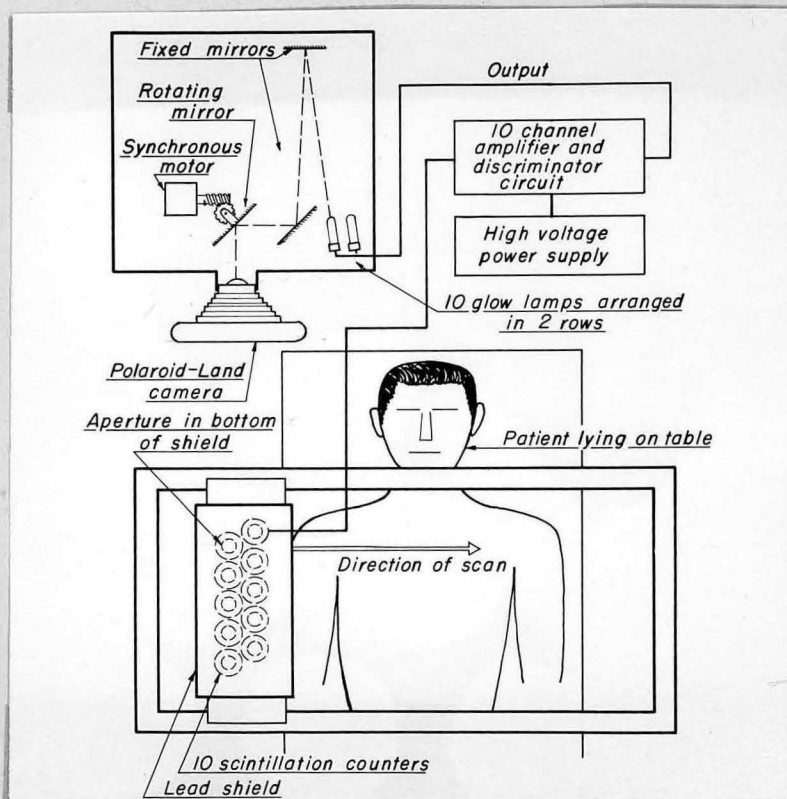

Fig. 4

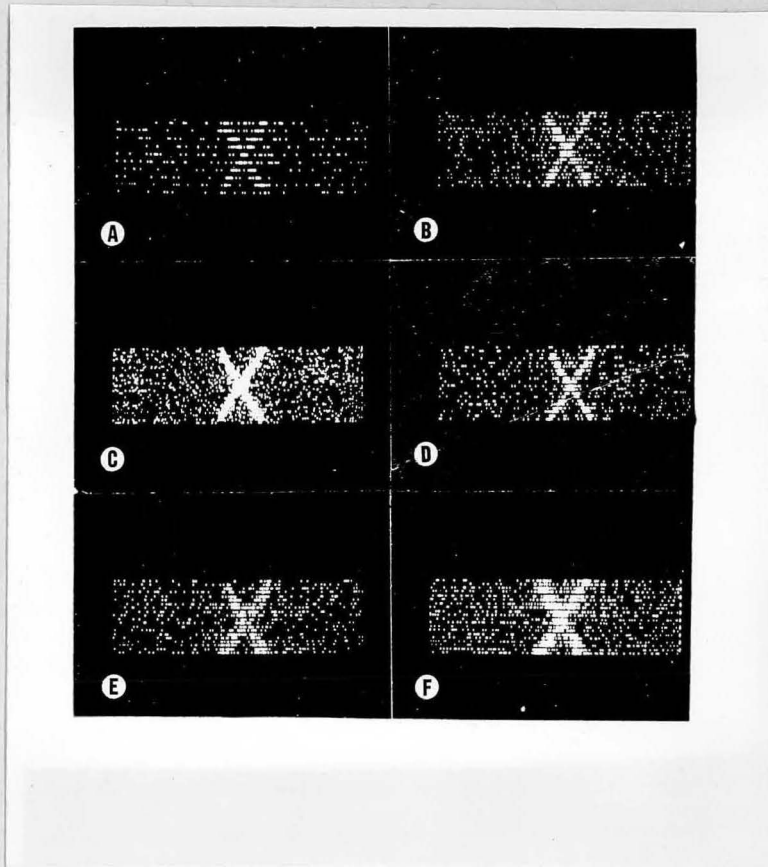

Fig. 5

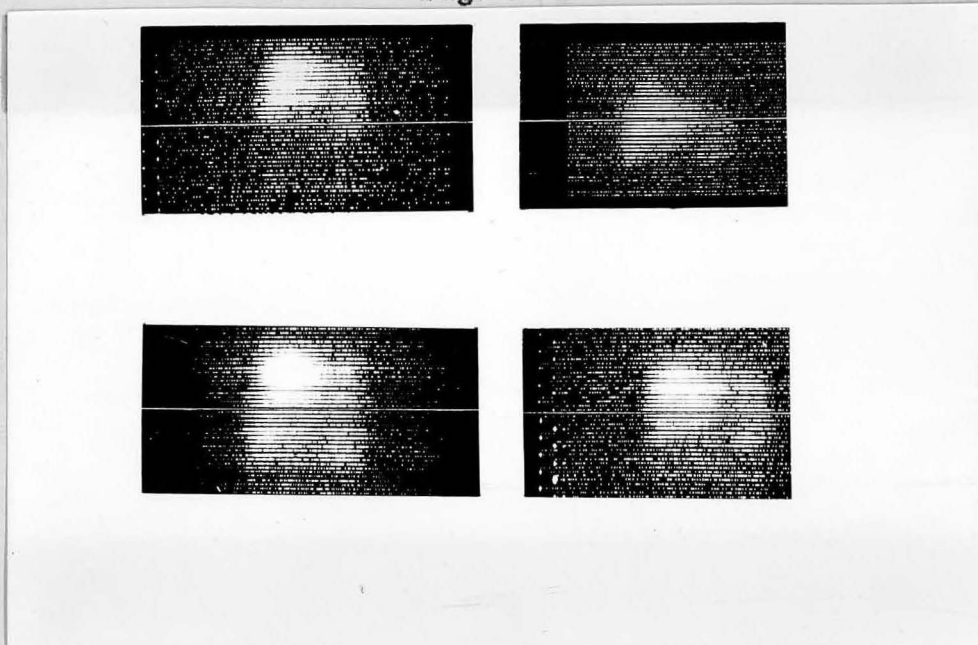
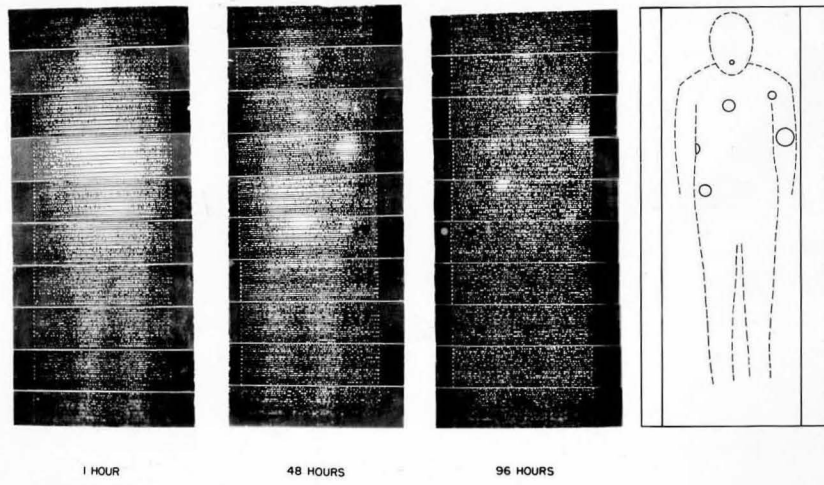

Fig. 6



1 HOUR

48 HOURS

96 HOURS

FRONT VIEW

Fig. 7