

UC Irvine

UC Irvine Electronic Theses and Dissertations

Title

Interference Alignment : Beyond Generic Channels

Permalink

<https://escholarship.org/uc/item/7rh4n787>

Author

Krishnamurthy, Sundar Rajan

Publication Date

2014

Peer reviewed|Thesis/dissertation

UNIVERSITY OF CALIFORNIA,
IRVINE

Interference Alignment : Beyond Generic Channels

DISSERTATION

submitted in partial satisfaction of the requirements
for the degree of

DOCTOR OF PHILOSOPHY

in Electrical and Computer Engineering

by

Sundar Rajan Krishnamurthy

Dissertation Committee:
Professor Syed Ali Jafar, Chair
Professor Hamid Jafarkhani
Professor Ender Ayanoglu

2014

DEDICATION

To my family

TABLE OF CONTENTS

	Page
LIST OF FIGURES	v
LIST OF TABLES	vii
ACKNOWLEDGMENTS	viii
CURRICULUM VITAE	ix
ABSTRACT OF THE DISSERTATION	xi
1 Introduction	1
1.1 Prior Art	2
1.1.1 Non-asymptotic schemes	2
1.1.2 Asymptotic schemes	3
1.2 Non-generic channels : Overview	5
1.3 Notation	7
2 Single-hop Rank-deficient Interference Channels	8
2.1 Motivations	8
2.1.1 Background	8
2.2 Summary of Contributions	11
2.3 System Model	12
2.4 2-user channel	14
2.4.1 Theorem 2.1: Proof of Achievability	15
2.4.2 Theorem 2.1: Proof of Outer Bound	18
2.5 3-user channel	20
2.5.1 Theorem 2.2: Proof of Achievability	21
2.5.2 Theorem 2.2: Proof of Outer Bound	29
2.6 K -user channel	34
2.6.1 Alignment with Spatial dependencies	37
2.6.2 Theorem 2.3: Proof of Achievability	42
2.6.3 Theorem 2.3: Proof of Outer Bound	61
2.7 Summary	68

3	Two-hop Rank-deficient Interference Channels	70
3.1	Motivations	70
3.2	System Model	72
3.3	Results	73
3.3.1	Rank-Mismatch Outer Bound	73
3.3.2	Tightness of Rank-Mismatch Outer Bounds	74
3.4	Proofs	75
3.4.1	Theorem 3.1 : Proof of Outer Bound	75
3.4.2	Theorem 3.2 : Proof of Achievability	79
3.5	Summary	88
4	Constant Finite field channels over \mathbb{F}_{p^n}	90
4.1	Motivations	90
4.2	X Channel	93
4.2.1	Prior Work	93
4.2.2	Finite Field X Channel Model	95
4.2.3	Zero Channels	96
4.2.4	X Channel Normalization	97
4.2.5	Capacity of the Finite Field X Channel	97
4.2.6	Achievability over \mathbb{F}_{p^2}	104
4.2.7	Achievability over \mathbb{F}_{p^3}	107
4.2.8	Achievability over \mathbb{F}_{p^n}	109
4.3	Interference Channel	115
4.3.1	Prior Work	115
4.3.2	Finite Field Interference Channel Model	117
4.3.3	Interference Channel Normalization	119
4.3.4	Linear-scheme Capacity of the Finite Field Interference Channel	120
4.3.5	Achievability	125
4.3.6	Linear outer bound	138
4.4	Summary	143
5	Conclusions	145
	Bibliography	147
A	Constant finite field channels : Proofs	152
A.1	Zero Channels in 3-user Interference channel	152

LIST OF FIGURES

	Page
2.1 K User MIMO Interference Network with Rank Deficient Channels	13
2.2 2-user Rank Deficient Interference Channel	15
2.3 Achievability for 2-user Rank deficient channel	16
2.4 3-user Rank Deficient Interference Channel	21
2.5 M -dimensional signal space in 3-user interference channel	24
2.6 Alignment in 3-user interference channel	27
2.7 Basis change for 3-user channel: $D_1 + D_2 > M$	31
2.8 Basis change for 3-user channel: $D_1 + D_2 \leq M$	33
2.9 DoF of K -user Rank Deficient Interference Channel with $M = 10$: Comparison with result of Chae at al. in [15]	35
2.10 DoF of K -user Rank Deficient Interference Channel	36
2.11 K -user interference channel: Decomposition	37
2.12 Example setting for $(K - 1)D \leq M$	44
2.13 Asymptotic alignment for K -user rank deficient channel with $M = 2$	55
2.14 Outer bound: K -user rank deficient interference channel, $(K - 1)D < M$	62
2.15 Outer bound: K -user rank deficient interference channel, $(K - 2)D \leq M <$ $(K - 1)D$	65
3.1 $2 \times 2 \times 2$ MIMO interference channel with M antennas at each node where all channels in the first hop have rank D_1 and all channels in the second hop have rank D_2	71
3.2 Change of Basis for Region 1. $D_1 > \frac{M}{2}, D_2 > \frac{M}{2}$	77
3.3 Change of Basis for Region 2. $D_1 \leq \frac{M}{2}, D_2 > \frac{M}{2}$	78
3.4 Change of Basis for Region 3. $D_1 > \frac{M}{2}, D_2 \leq \frac{M}{2}$	79
3.5 2-hop interference channel : 4 Regimes	80
3.6 Constructed channel for Regime 1	81
3.7 Constructed channel for Regimes 2 and 3	82
3.8 Constructed channel for Regime 4.	84
4.1 Wired network modeled as 2-user X channel	92
4.2 Normalization in X channel	93
4.3 An instance of the X channel over \mathbb{F}_{33} and its capacity optimal solution represented in scalar notation.	103
4.4 The same example and solution as Fig. 4.3, illustrated in vector notation.	103
4.5 Algorithm for the construction of precoding vectors.	111
4.6 Wired network modeled as 3-user interference channel	116

4.7	Normalization in 3-user Interference Channel	118
4.8	3-user Interference channel over \mathbb{F}_{p^3}	126
4.9	3-user Interference channel over $\mathbb{F}_{p^n}, n = 2l + 1$	128
4.10	3-user Interference channel over \mathbb{F}_{p^2}	133
4.11	Alignment depth in 3-user Interference channel	140
4.12	Distinct channel structures with 3 cross channels as 0	142

LIST OF TABLES

	Page
1.1 Results Overview	6
2.1 Achievable DoF in 3-user channel for different D_1, D_2 with $D_0 = M$	23
3.1 DoF achieved by each scheme in different regimes	84
4.1 Summary — 2-user X channel over finite fields	100
4.2 Summary — 3-user Interference channel over finite fields	124

ACKNOWLEDGMENTS

First, I consider myself very fortunate to be advised by Prof. Syed Ali Jafar. His ingenuity, passion, and attention to detail have motivated me tremendously to find and push my boundaries. His insightful approach and perseverance when solving complex problems, clarity of thought, and an unyielding emphasis on precision and conciseness will inspire me throughout my life. I'm very grateful for his patience when advising me. I have significantly benefitted from the numerous meetings and his courses, when he would surprise many of us with his invaluable insights and intuitions. I hope I can meet some of his high professional standards, during the course of my life.

I would like to thank Prof. Hamid Jafarkhani and Prof. Ender Ayanoglu for serving in my dissertation committee and reviewing my Thesis. I've enjoyed learning Space time coding and Digital communications from them. I'm highly indebted to Prof. A. Lee Swindlehurst for bringing me to U.C. Irvine, and for his research support and guidance during my first year. I would like to thank Prof. Yaming Yu for solving a tough problem that helped us change our direction.

Special thanks to all the staff in the EECS department office for helping me in various stages of my work - especially Susan, Amy and Loretta.

My gratitude extends to Prof. Chari (late) and Mr. Vijaykumar, who shaped my early interests in applied mathematics in school. I would also like to acknowledge Prof. J.C. Pant at BITS for being a motivating Math professor. My special gratitude goes to Prasad VTSV, research lead at Samsung R & D Institute India, for his clarity of thought and for inspiring me to pursue research in my field.

I would like to thank Dr. Viveck Cadambe, Dr. Tiangao Gou and Dr. Chenwei Wang, for the countless discussions on Interference Alignment. I'm thankful to Abinesh Ramakrishnan and Hua Sun for collaborating and co-authoring some of our papers. I thank Dr. Hamed Maleki and Chunhua Geng for many interesting discussions. It has been a very rewarding experience interacting with each one of them.

I'm glad to have found a great circle of friends who have made my time in U.C. Irvine a very memorable one - Viveck, Sneha, Janice, Nilopa, Avi, Vivek, Rama, Sravanthi, Sridevi, Subhanshu, Jie and Feng. I'm short of words to thank Sai for being with me through thick and thin.

Last but not the least, I'm extremely grateful to have my parents, siblings and Pavitra in my life, and for their unfailing strength and support.

CURRICULUM VITAE

Sundar Rajan Krishnamurthy

EDUCATION

Doctor of Philosophy in Electrical Engineering	2014
University of California, Irvine	<i>Irvine, CA</i>
Master of Science in Electrical Engineering	2011
University of California, Irvine	<i>Irvine, CA</i>
B.E. (Honors) in Electrical Engineering	2003
Birla Institute of Technology & Science, Pilani	<i>Rajasthan, India</i>

RESEARCH EXPERIENCE

Graduate Student Researcher	2009–2014
University of California, Irvine	<i>Irvine, CA</i>
Intern	Summer 2011
Broadcom Corporation	<i>Matawan, NJ</i>
Intern	Spring 2010
Powerwave Technologies	<i>Santa Ana, CA</i>
Lead Engineer	2004–2009
Samsung R & D Institute, India	<i>Bangalore, India</i>
Software Engineer	2003–2004
Intel Corporation, India	<i>Bangalore, India</i>

TEACHING EXPERIENCE

Teaching Assistant	2010–2011
University of California, Irvine	<i>Irvine, CA</i>
Courses: Computational Methods in ECE & Engineering Probability	

REFEREED JOURNAL PUBLICATIONS

Sundar R. Krishnamurthy, Abinesh Ramakrishnan, Syed A. Jafar, “Degrees of Freedom of Rank Deficient MIMO Interference Networks” **Oct 2013**

IEEE Transactions in Information Theory - In review

Sundar R. Krishnamurthy, Syed A. Jafar, “On the Capacity of the Finite Field Counterparts of Wireless Interference Networks” **July 2014**

IEEE Transactions in Information Theory, Vol. 60, no. 7, pp. 4101- 4124 (Arxiv: 1304.7745)

Hua Sun, Sundar R. Krishnamurthy, Syed A. Jafar, “Rank-Matching for Multihop Multiflow” **May 2014**

IEEE Transactions in Information Theory - In review (Arxiv: 1405.0724)

SELECTED CONFERENCE PUBLICATIONS

Sundar R. Krishnamurthy, Syed A. Jafar, ”Rank-Matching for Multihop Multiflow” **Dec 2014**

IEEE Global Telecommunications Conference (GLOBECOM), Austin

Abinesh Ramakrishnan, Sundar R. Krishnamurthy, Syed A. Jafar, Yaming Yu, “Degrees of Freedom of Interference channel with Rank-Deficient Transfer matrix” **July 2014**

IEEE International Symposium on Information Theory (ISIT), Honolulu

Sundar R. Krishnamurthy, Syed A. Jafar, “Precoding Based Network Alignment and Capacity of a Finite Field X Channel” **July 2013**

IEEE International Symposium on Information Theory (ISIT), Istanbul

Sundar R. Krishnamurthy, Syed A. Jafar, ”Degrees of Freedom of 2-user and 3-user Rank-Deficient MIMO Interference Channels” **Dec 2012**

IEEE Global Telecommunications Conference (GLOBECOM), Anaheim

SOFTWARE

Matlab, C, C++

WEBSITE

<https://sites.google.com/site/sundarrkrish/>

ABSTRACT OF THE DISSERTATION

Interference Alignment : Beyond Generic Channels

By

Sundar Rajan Krishnamurthy

Doctor of Philosophy in Electrical and Computer Engineering

University of California, Irvine, 2014

Professor Syed Ali Jafar, Chair

Capacity characterization of communication networks is the most fundamental problem in Information Theory, that underlies the design of various wireless and wired networks. The radical idea of “Interference alignment” has enabled Capacity or Degrees of Freedom characterization (DoF, a first order approximation) for many interference networks. Various alignment schemes developed have provided new and fundamental insights into the number of accessible signal dimensions in communication networks where the output signals are linear functions of the input signals. Most of the prior art deal with generic channels wherein the channel coefficients are assumed to be independent and drawn from a continuous distribution, continuous alphabet with infinite diversity, and the network is often single-hop. These assumptions are challenged due to the following reasons : 1) In MIMO systems, poor scattering environment and network topology lead to spatial dependencies that are manifested as rank deficient channels, 2) Multi-hop dependencies arise due to the presence of relays, and 3) Linear network coding applications (as in wired networks) act as finite field counterparts of wireless networks, with limited diversity.

In this thesis, Capacity / DoF of linear communication networks are characterized for “Non-generic channels”. One of the significant problems considered is the DoF of the K -user MIMO rank deficient interference channel, with different ranks for the direct and the cross channels. For this rank deficient interference channel, it is shown that the rank deficiency of direct channels does not help

DoF and the rank-deficiency of cross-channels does not hurt DoF. The main challenge is to account for the spatial dependencies introduced by rank deficiencies in the interference alignment schemes that typically rely on the independence of channel coefficients. Another interesting problem is the DoF of Two-hop MIMO rank deficient interference channel with different channel ranks in the first and the second hops, for which a rank-matching principle is identified reminiscent of impedance matching in circuit theory. For this channel, the DoF loss is shown to be the rank-mismatch between the two hops. Finally, capacity results for the finite field counterparts of wireless networks are presented, exploring the implications of channels being from a finite alphabet with limited diversity. By characterizing the capacity of constant finite field channels over \mathbb{F}_p^n for 2-user X channel and 3-user interference channel, interesting parallels are drawn between p and SNR, and n and Channel Diversity.

Chapter 1

Introduction

Capacity characterization of communication networks is the central problem in network information theory. While exact capacity characterizations remain open for several multi-user interference networks, *Interference alignment* has enabled characterization of the Degrees of Freedom (DoF, a first order approximation of capacity) for a broad array of wireless and wired communication networks. The idea of interference alignment originated out of the studies of the index coding problem [4] and the degrees of freedom (DoF) of X channels [35, 28] and K -user interference channels [9]. The rationale behind interference alignment is to consolidate the interference into a smaller subspace at all receivers, while keeping the desired signals separable from interference so that they can be recovered free of interference. For example, in the case of interference channel, interference is aligned at every receiver within one half of the total signal space available at that receiver, leaving the other half interference-free for the desired signals (*Half the cake* result of [9]).

Signal space alignment based on linear precoding (beamforming) schemes is the simplest form of alignment, and is called *Linear interference alignment*. Such alignment could be performed over different signal dimensions - time / frequency / space. The use of multiple antennas is widely known to provide higher throughput in wireless networks. Alignment through spatial precoding /

multiplexing is significant since it combines the benefits of both interference alignment and MIMO (Multiple Input Multiple Output). Hence, extensive research efforts have been dedicated to the study of Interference Alignment over MIMO interference networks.

We will now briefly discuss the relevant prior art.

1.1 Prior Art

Linear alignment schemes may be broadly classified into non-asymptotic and asymptotic schemes, based on whether the size of the linear precoding vector space required to approach the optimal DoF value is finite or infinite, respectively. Non-asymptotic schemes typically suffice for under-constrained systems, where the number of spatial dimensions (antennas) is sufficiently large relative to the number of alignment constraints (users). This is the case, e.g., in the 2-user and 3-user MIMO interference channels, studied in [27] and [55], respectively. Asymptotic schemes, based on a construction proposed by Cadambe and Jafar in [9] for the K -user interference channel with time-varying/frequency-selective channel coefficients (CJ scheme), are typically needed when the number of alignment constraints (users) dominates the number of spatial dimensions (antennas).

1.1.1 Non-asymptotic schemes

2-user and 3-user Interference Channels

The DoF of the 2-user MIMO interference channel with arbitrary number of antennas at each node are characterized in [27]. The DoF of the 3-user MIMO interference channel where all nodes have the same number of antennas are characterized by Cadambe and Jafar in [9]. The DoF of 3-user MIMO interference channel with M antennas at each transmitter and N antennas at each receiver are characterized in parallel works by Wang et al. in [55] and by Bresler et al. in [5].

X Channel

The DoF of the 2-user X channel were characterized in [35, 28], for a system with two transmitters, two receivers, each equipped with multiple antennas, wherein independent messages are sent from each transmitter to each receiver. When each node has M antennas, sum DoF was found to be $\frac{4M}{3}$. To this end, signal spaces are aligned at receivers where they constitute interference while they are separable at receivers where they are desired.

2-hop Interference Channel

The $2 \times 2 \times 2$ interference channel, which is a layered network comprised of two source nodes, two relay nodes and two destination nodes, is an elemental model for the study of the information theoretic foundations of multihop multifold networks. Many of the key ideas behind multihop multifold networks, such as interference neutralization [39], aligned interference neutralization [22], aligned interference diagonalization [48], opportunistic scheduling [1], network condensation and manageable interference [49, 54] have been discovered through the degrees of freedom (DoF) studies of the $2 \times 2 \times 2$ interference channel and its natural extensions to more than 2 sources/relays/destinations/hops, arbitrary topologies, and even non-layered settings [23].

1.1.2 Asymptotic schemes

K -user Interference Channel

The CJ scheme introduced by Cadambe and Jafar in [9] showed that the K user interference channel with a single antenna at each node (SISO setting) has a total of $\frac{K}{2}$ DoF almost surely. The key to this result was aligning interference almost perfectly in half of the received signal space by precoding over an asymptotically large number of channel uses, over *independently* time-varying

or frequency-selective channels. Achieving DoF of $\frac{1}{2}$ per user (*Half the cake*) is a remarkable improvement over orthogonalization approaches for which DoF are $\frac{1}{K}$ per user (*cake-cutting*), especially for large number of users. When there are M antennas at each node, DoF per user are known to be $\frac{M}{2}$, achievable by decomposition of the antennas at all transmitters and receivers (treat as separate nodes). The CJ scheme forms the basis of many, if not most, asymptotic schemes encountered in a variety of settings ranging from X networks [10], cooperative and cognitive communications [53, 56, 57], to distributed storage exact repair [13] and multiple unicast network coding [37], and translates, quite remarkably, into the rational dimensions framework for constant channels as well [40, 31].

M, N -user X Channel

The DoF of $M \times N$ user X networks were found by Cadambe and Jafar in [10]. Here, there are M transmitters, N receivers and each transmitter has an independent message for every receiver. For the SISO channel, when all channel coefficients vary in time or frequency, sum DoF was shown to be $\frac{MN}{M+N-1}$ per signal dimension. Achievability was shown using an asymptotic interference alignment scheme similar to [9], wherein interference is aligned within a $N - 1$ dimensional space at each receiver and desired signals of M dimensions are decoded. Later, Sun et al. showed in [51] that the sum DoF to be $A \frac{MN}{M+N-1}$ for similar network with A antennas at each node. This resolved a discrepancy between the spatial scale invariance conjecture (scaling number of antennas at each node by a constant factor will scale total DoF by the same factor - [55]) and a decomposability property of overconstrained networks. The new insight was that the MIMO X network is only one-sided decomposable without loss of DoF.

1.2 Non-generic channels : Overview

Most of the prior art assume that the channels are *generic*. With few exceptions, the studies of interference alignment schemes assume that the

- Channels are drawn from a continuous distribution with some form of independence (linear, probabilistic, algebraic, rational) of channel realizations (e.g., i.i.d.)
- Network is single-hop
- Channels are drawn from a continuous alphabet with infinite diversity

We consider the above 3 characteristics to be representative of generic channels. These characteristics of generic channels are challenged due to the presence of some form of *dependencies* or *diversity constraints*, resulting in *non-generic* channels. Understanding the implications of such non-generic channels on the signaling dimensions of interference networks is a significant and challenging problem. To study non-generic channels, we assume that each of the above 3 generic channel characteristics fail to hold, in the following manner.

- Channels are algebraically dependent, due to the presence of rank deficiencies
- Network dependencies arise due to a multi-hop topology
- Channels belong to a finite alphabet with limited diversity

Above 3 aspects of non-generic channels and their impact on signaling dimensions of interference networks can be understood through the study of the following categories of *non-generic* channels, respectively.

1. Single-hop rank deficient interference channels

2. Multi-hop rank deficient interference channels

3. Finite field channels over \mathbb{F}_{p^n}

We study the impact of channel dependencies by considering rank-deficient channels in MIMO interference networks. Rank deficient channels are frequently encountered in MIMO networks, due to poor scattering, presence of single or very few paths, insufficient antenna-spacing, keyhole effects and network topology. While the implications of rank deficient channels are well understood for the single user point to point setting, much less is known for interference networks. In order to understand the impact of additional network dependencies, we consider relay networks with MIMO, modeled through multi-hop rank-deficient channels wherein the channel ranks in the various hops are different. Interference networks with backhaul links of different capacities can also be modeled as multi-hop rank-deficient channels. Finite field channels arise in linear network coding applications in wired networks wherein the intermediate nodes perform arbitrary linear operations and the intelligence resides mainly at the sources and the destinations. Overview of the DoF or capacity results is provided in Table 1.1.

Table 1.1: Results Overview

Channel	Parameters	DoF / Capacity
Single-hop rank deficient interference channel		
2-user channel	M_i, N_j, D_{ji}	DoF = $\min(D_{11} + D_{22}, M_1 + N_2 - D_{21}, M_2 + N_1 - D_{12})$
3-user channel	M, D_0, D_1, D_2	DoF = $3 \min \left(D_0, M - \frac{\min(M, D_1 + D_2)}{2} \right)$
K -user channel	M, D_0, D	DoF = $K \min \left(D_0, M - \frac{\min(M, (K-1)D)}{2} \right)$
Multi-hop rank deficient interference channel		
2-hop channel	M, D_1, D_2	DoF = $\min(4D_1, 4D_2, 2M - D_1 - D_2)$
Constant Finite field channels over \mathbb{F}_{p^n}		
2-user X channel	\mathbf{h}	Capacity, $C = C_{linear} = \frac{4}{3}$, $h \notin \mathbb{F}_p$
3-user interference channel	$\mathbf{h}, \mathbf{h}_{11}, \mathbf{h}_{22}, \mathbf{h}_{33}$	Linear-scheme Capacity, $C_{linear} = \frac{3l+1}{2l+1}$, $n = 2l + 1$

In Section 2, DoF results are presented for single-hop rank deficient MIMO interference channels, with different direct and cross channel ranks. It is shown that the direct channel rank deficiencies cannot help DoF and could only hurt, while the cross channel rank deficiencies cannot hurt DoF and could improve. In Section 3, we discuss the DoF results for 2-hop rank deficient MIMO interference channel with different channel ranks in 2 hops. A rank matching principle is identified similar to impedance matching in circuit theory, where the goal is to match channel ranks over the 2 hops. Under moderate rank deficiencies, DoF loss is found to be rank mismatch between the two hops. Section 4 explains the capacity results for 2-user finite field X channel and 3-user finite field interference channel with constant channels from \mathbb{F}_{p^n} . Scalar SISO \mathbb{F}_{p^n} channels are noted to be equivalent to $n \times n$ MIMO channels over \mathbb{F}_p , using which DoF optimal results of wireless networks are translated to capacity or linear-scheme capacity optimal results for their finite field counterparts. Through the study of finite field channel \mathbb{F}_{p^n} , interesting parallels are drawn between p and SNR, and n and diversity.

1.3 Notation

\mathbb{Z}_+ denotes the set of positive integers, and \mathbb{C} denotes the set of complex numbers. For the matrix \mathbf{H} , $\mathbf{H}(i, :)$ and $\mathbf{H}(:, j)$ denote its i th row and j th column vector, respectively. When dealing with $\mathbf{H}_{k(k+1)}$ and $\mathbf{H}_{k(k-1)}$, indexing is interpreted in a circular wrap-around manner, modulo the number of users, e.g., the k -th user is same as the 0-th user. We use the notation $o(x)$ to represent any function $f(x)$ such that $\lim_{x \rightarrow \infty} \frac{f(x)}{x} = 0$. We denote the number of columns of matrix \mathbf{V} as $|\mathbf{V}|$, and \mathbf{V}^\dagger is used to denote the conjugate transpose of matrix \mathbf{V} . The term nullspace refers to the right nullspace, unless otherwise explicitly mentioned. $(x)^+$ indicates $\max(0, x)$. \mathbf{I}_M denotes the $M \times M$ identity matrix and \otimes denotes the Kronecker product. Matrices are notated using bold font while vectors are denoted with normal font.

Chapter 2

Single-hop Rank-deficient Interference Channels

2.1 Motivations

In this section, we study the degrees of freedom (DoF) of rank-deficient MIMO interference networks. To isolate the impact of *spatial* dependencies, we allow channels to vary independently across time and frequency. This also allows us to exploit the well-developed machinery of *linear* interference alignment schemes, which are appealing not only for their simplicity and robustness, but also because they tend to be DoF-optimal for time-varying channels.

2.1.1 Background

Our study of non-asymptotic schemes will focus on 2-user and 3-user MIMO interference channels, whereas asymptotic schemes will be studied through the K -user MIMO interference channel setting. The relevant background is summarized in this section.

Non-asymptotic schemes: 3-user MIMO Interference Channels

The DoF of 3-user MIMO interference channel with M antennas at each transmitter and N antennas at each receiver are characterized in parallel works by Wang et al. in [55] and by Bresler et al. in [5]. While the achievability results are the same in the two works, the outer bounds presented by Wang et al. are strictly stronger. The outer bounds of Bresler et al. are restricted to the linear feasibility of [19, 60] where only linear precoding schemes are considered, and precoding across multiple channel uses is not allowed. However, Wang et al. present information theoretic outer bounds that are also applicable to non-linear schemes, arbitrary channel extensions, and time-varying channels. Remarkably, in spite of the more general setting, the information theoretic bounds of [55] match the linear outer bounds of [5]. Since information theoretic bounds directly imply linear outer bounds, the linear outer bounds of Bresler et al. are immediately recovered as special cases of the information theoretic outer bounds of Wang et al. Comparing achievability and outer bounds, the two coincide in the sense of a spatially normalized DoF metric. Whether the achievability matches the outer bound without the spatial normalization is subject to the validity of the spatial invariance conjecture of Wang et al. [55], which essentially states that time, frequency and space dimensions are equivalent from a DoF perspective (so that there is no loss of generality in a spatial normalization). Remarkably, with the exception of the single-antenna setting, only non-asymptotic interference alignment schemes are used in [55, 5] to achieve the DoF outer bounds.

Asymptotic schemes

Originally proposed for the SISO setting, the CJ scheme was directly extended to the K user MIMO interference channel in [9] by a decomposition approach, viewing a K user interference channel where each node has M antennas, as a KM user interference channel where each node has a single antenna. The decomposition approach achieves the optimal DoF value of $\frac{KM}{2}$ for this

network. Applying the CJ scheme to the SISO setting obtained by the decomposition of a MIMO interference channel, is also shown to be a DoF optimal strategy in [18, 58] for K user MIMO interference networks where each transmitter has M antennas and each receiver has N antennas, provided that the number of users exceeds a threshold that depends on M, N . The need for a SISO decomposition for the CJ scheme can be understood as follows: The CJ scheme requires commutativity of matrix multiplication, which is not satisfied by the generic channel matrices in MIMO networks (which produce non-commuting block diagonal channels). However, decomposing the MIMO network into a SISO network and allowing channel extensions over time/frequency creates diagonal channel matrices, which satisfy the commutative property. While at first, the limitation of having to decompose MIMO channels, may appear to be a limitation of the CJ scheme, it is remarkable that the CJ scheme remains DoF optimal in spite of the decomposition. The decomposability property is further discussed in [51, 58, 50].

Rank-Deficient MIMO Interference Networks

For rank deficient MIMO interference networks, much less is known. A study of achievable DoF is initiated by Chae et al. in [15] under the assumption that there are M antennas at each transmitter, N antennas at each receiver, and that the $N \times M$ channel matrix from each transmitter to each receiver is of rank D . However, in the absence of outer bounds for rank-deficient channels, the optimality of the achieved DoF is not settled. Following the preliminary version of this work [33], Zeng et al. have found the DoF for the 3-user rank deficient interference channel independently and in parallel work [62], with M_T antennas at all transmitters and M_R antennas at all receivers and with channel matrices of rank $D_i, i \in \{1, 2, 3\}$. Other studies of rank-deficient wireless networks include the DoF characterization of 2-user rank deficient MIMO X channel under arbitrary antenna configurations by Agustin and Vidal in [2].

2.2 Summary of Contributions

First, let us consider settings that correspond to non-asymptotic schemes. Interference alignment and zero-forcing through spatial beamforming are the core principles of non-asymptotic linear interference management schemes. Interestingly, rank-deficiencies impact the two in opposite ways, favoring one and limiting the other. Rank-deficiencies create *more* opportunity for zero-forcing because the channel null-space size is increased. However, there is *less* opportunity for interference alignment because reduced range spaces imply reduced overlaps between range spaces. Given the contrasting effects on alignment and zero-forcing, it is not clear a-priori whether the overall impact of rank-deficiencies should be positive or negative. Our results for rank-deficient 2-user and 3-user MIMO interference channels shed light on this tradeoff. For both 2-user and 3-user rank deficient MIMO interference channels, our focus is mainly on achievable schemes for constant channels, which can also be used for time-varying channels. For the 2-user rank deficient MIMO interference channel, we (i) provide a tight outer bound to show that the previously known achievable DoF found by Chae et al. in [15] in the *symmetric* case are optimal, and (ii) we generalize the result to fully asymmetric settings. For the 3-user rank deficient MIMO channel, we characterize the DoF of a cyclically symmetric setting where all nodes have the same number of antennas (M). Our DoF results for the 3-user case are consistent with those derived in parallel work by Zeng et al. if we set $M_T = M_R$ in [62], however while the achievable scheme of [62] requires asymptotic number of symbol extensions when $M_T = M_R$, we present a non-asymptotic achievable scheme that requires at most two symbol extensions.

Next, let us consider asymptotic schemes, and in particular, the idea of decomposing the MIMO network into a SISO network where the CJ scheme is applicable. If the MIMO channels were comprised of independent channel coefficients, then the decomposition of the MIMO network into a SISO network preserves the channel independence requirements of the CJ scheme. With rank-deficiencies, however, this is no longer the case. The direct and cross channels are dependent in the decomposed SISO network and it is easy to see that the basic requirements of the CJ scheme

are violated. If the CJ scheme is directly applied there must be a loss of DoF due to the channel dependencies. This observation is particularly ominous given that viable alternatives to the CJ scheme are not known for over-constrained interference networks. Our results for rank-deficient K -user MIMO interference channels shed light on this conundrum. For K -user rank deficient MIMO interference channel, we study achievable schemes for time-varying channels, which often serve as stepping stones to translate DoF results to constant channels. In particular, we show that for the K -user rank deficient interference channel, when all nodes have M antennas, all direct channels have rank D_0 , all cross channels are of rank D , and the channels are otherwise generic, the optimal DoF value per user is $\min(D_0, M - \frac{\min(M, (K-1)D)}{2})$. Our result improves upon the best known achievable DoF from prior work, and we present a tight outer bound to prove its optimality.

Remarkably, our results indicate that for interference channels, the rank-deficiency of direct channels does not help and the rank-deficiency of cross-channels does not hurt. The main technical challenge in the paper is to account for the spatial dependencies introduced by rank deficiencies in the interference alignment schemes that typically rely on the independence of channel coefficients.

We start with a general system model which will be specialized in later sections for different settings.

2.3 System Model

The K -user MIMO interference channel is comprised of K transmitters, K receivers, and K independent messages. Transmitter k denoted as T_k , is equipped with M_k antennas and has message W_k intended for its corresponding receiver, Receiver k denoted as R_k , which is equipped with N_k antennas. At time index $t \in \mathbb{Z}^+$, Receiver j observes the vector $Y_j(t) \in \mathbb{C}^{N_j \times 1}$ given by

$$Y_j(t) = \sum_{i=1}^K \mathbf{H}_{ji}(t)X_i(t) + Z_j(t) \quad (2.1)$$

wherein $X_i(t) \in \mathbb{C}^{M_i \times 1}$ is the vector sent from Transmitter i , $\mathbf{H}_{ji}(t) \in \mathbb{C}^{N_j \times M_i}$ is the channel matrix between Transmitter i and Receiver j and $Z_j(t) \in \mathbb{C}^{N_j \times 1}$ is the i.i.d. zero mean unit variance circularly symmetric complex additive white gaussian noise (AWGN) vector. Each transmitter must satisfy an average power constraint $\mathbb{E}(\|X_i(t)\|^2) \leq \rho$, where ρ is referred to as the Signal-to-Noise Power Ratio, or the SNR. Global channel knowledge is assumed to be perfectly available at all nodes, and the transmitters are assumed to know the channels instantaneously.

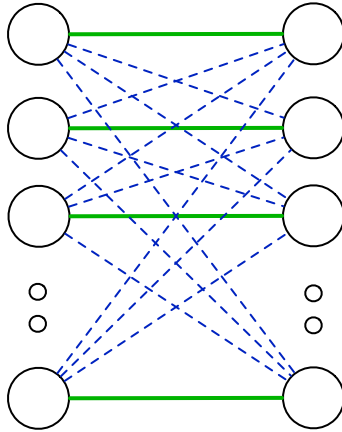

Figure 2.1: K User MIMO Interference Network with Rank Deficient Channels

The most important aspect of the system model for this work is the assumption that channels matrices are rank-constrained, so that the channel matrix $\mathbf{H}_{ji}(t)$ has rank D_{ji} almost surely. Aside from the rank-constraint, the channel matrices are generic, i.e., they possess no special structure. Mathematically, an $N_j \times M_i$ generic matrix subject to a rank-constraint D_{ji} may be defined as the product of a pair of independently generated matrices of dimensions $N_j \times D_{ji}$ and $D_{ji} \times M_i$, each of which has its elements drawn from a continuous distribution with support bounded away from zero and infinity.

Achievable rates, capacity region, and DoF are defined in the standard sense (see, e.g., [9]). In this work we are primarily interested in the sum-DoF value for almost all channel realizations, defined as $d_\Sigma = \lim_{\rho \rightarrow \infty} R_\Sigma(\rho) / \log(\rho)$, wherein $R_\Sigma(\rho)$ is the maximum sum rate of the channel at Signal-to-noise ratio, ρ . We also denote the sum DoF as $\text{DoF}_\Sigma(M_i, N_j, D_{ji})$, and the sum DoF

normalized by the spatial dimension as

$$\overline{\text{DoF}}_{\Sigma}(M_i, N_j, D_{ji}) = \max_{q \in \mathbb{Z}_+} \frac{\text{DoF}_{\Sigma}(qM_i, qN_j, qD_{ji})}{q} \quad (2.2)$$

2.4 2-user channel

The DoF of the 2-user rank deficient interference channel is presented in the following theorem.

THEOREM 2.1. *For the 2-user rank deficient MIMO interference channel, the sum-DoF value is given by*

$$\text{DoF}_{\Sigma} = \min\{D_{11} + D_{22}, M_1 + N_2 - D_{21}, M_2 + N_1 - D_{12}\} \quad (2.3)$$

Placing the result in perspective with prior work, recall that in [15] Chae et al. have considered a symmetric version of the 2-user MIMO interference channel, for which they have established an achievable DoF value. Theorem 2.1 shows that the achievable DoF value of Chae et al. is optimal in the symmetric setting, and generalizes the result to arbitrary antenna configurations and arbitrary rank-constraints, shown in Figure 2.2. Above DoF result holds for both time-varying and constant channel coefficients.

Note that rank-deficiency of direct channels does not help the DoF and the rank-deficiency of cross-channels does not hurt. Since interference-alignment is not a possibility, the achievability is based on simple zero-forcing, which benefits from the increased null-space of cross channel matrices.

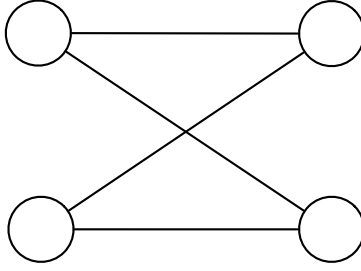

Figure 2.2: 2-user Rank Deficient Interference Channel

2.4.1 Theorem 2.1: Proof of Achievability

Since the proof is similar to that of the 2-user full rank interference channel [27], we do not repeat all the details. Transmitter i has M_i antennas, Receiver j has N_j antennas and the channel between Transmitter i and Receiver j is of rank D_{ji} . Figure 2.3 illustrates the proof setting with an example where $M_1 = 5$, $M_2 = 4$, $N_1 = 4$, $N_2 = 4$, $D_{11} = 3$, $D_{22} = 3$, $D_{12} = 2$ and $D_{21} = 4$, where a total of 5 DoF are achieved.

Step 1: We consider a singular value decomposition (SVD) of the interference channels $\mathbf{H}_{12} = \mathbf{U}_1 \mathbf{\Lambda}_{12} \mathbf{V}_1^\dagger$ and $\mathbf{H}_{21} = \mathbf{U}_2 \mathbf{\Lambda}_{21} \mathbf{V}_2^\dagger$ wherein $\mathbf{U}_1, \mathbf{U}_2, \mathbf{V}_1, \mathbf{V}_2$ are $N_1 \times N_1, N_2 \times N_2, M_2 \times M_2, M_1 \times M_1$ unitary matrices, respectively. $\mathbf{\Lambda}_{12}$ and $\mathbf{\Lambda}_{21}$ are $N_1 \times M_2, N_2 \times M_1$ diagonal matrices with singular values of $\mathbf{H}_{12}, \mathbf{H}_{21}$ respectively on the main diagonal and zeros elsewhere. Using the standard MIMO SVD diagonalization approach as in [27], we absorb the unitary matrices into the corresponding input and output vectors as:

$$\bar{Y}_1 = \bar{\mathbf{H}}_{11} \bar{X}_1 + \mathbf{\Lambda}_{12} \bar{X}_2 + \bar{Z}_1 \quad (2.4)$$

$$\bar{Y}_2 = \bar{\mathbf{H}}_{22} \bar{X}_2 + \mathbf{\Lambda}_{21} \bar{X}_1 + \bar{Z}_2 \quad (2.5)$$

where $\bar{Y}_1 = \mathbf{U}_1^\dagger Y_1$, $\bar{Y}_2 = \mathbf{U}_2^\dagger Y_2$, $\bar{X}_1 = \mathbf{V}_2^\dagger X_1$, $\bar{X}_2 = \mathbf{V}_1^\dagger X_2$, $\bar{Z}_1 = \mathbf{U}_1^\dagger Z_1$, $\bar{Z}_2 = \mathbf{U}_2^\dagger Z_2$, $\bar{\mathbf{H}}_{11} = \mathbf{U}_1^\dagger \mathbf{H}_{11} \mathbf{V}_2$ and $\bar{\mathbf{H}}_{22} = \mathbf{U}_2^\dagger \mathbf{H}_{22} \mathbf{V}_1$. Here, $\bar{Y}_j, \bar{Z}_j, \forall j \in \{1, 2\}$ are $N_j \times 1$ vectors and

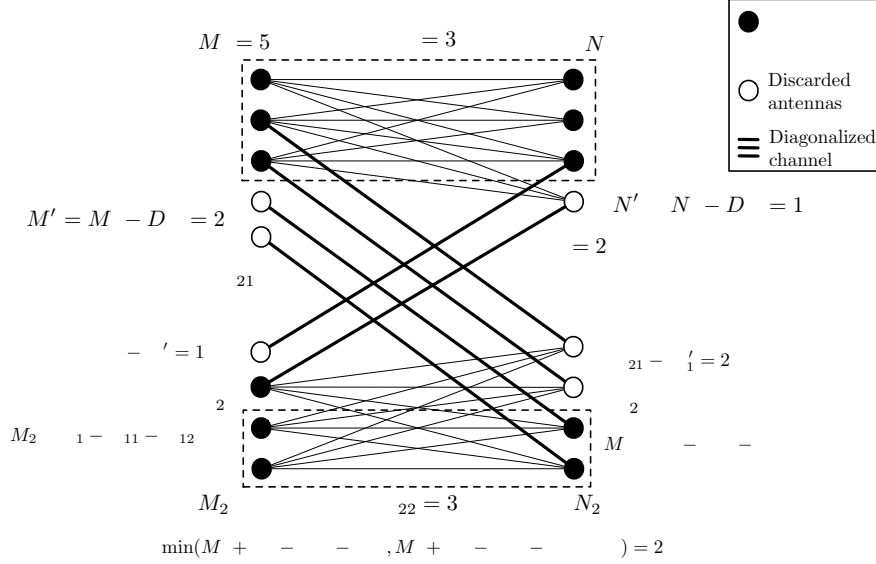

Figure 2.3: Achievability for 2-user Rank deficient channel

$\bar{X}_i, \forall i \in \{1, 2\}$ are $M_i \times 1$ vectors. Element m (m -th row) of \bar{X}_i, \bar{Y}_i are represented as \bar{X}_i^m, \bar{Y}_i^m , respectively. Since first D_{12} columns of Λ_{12} have nonzero values on the diagonal and other columns are zeros, only $\bar{X}_2^1, \bar{X}_2^2, \dots, \bar{X}_2^{D_{12}}$ present interference from T_2 at R_1 . Similarly only $\bar{X}_1^1, \bar{X}_1^2, \dots, \bar{X}_1^{D_{21}}$ present interference from T_1 at R_2 . Thick lines in Figure 2.3 represent interference links after diagonalization, and there are 2 parallel paths from T_2 to R_1 and 4 parallel paths from T_1 to R_2 .

Step 2: At Transmitter T_1 , inputs $\bar{X}_1^1, \bar{X}_1^2, \dots, \bar{X}_1^{(M_1 - D_{11})}$ are set to zero, i.e., we do not transmit on these inputs, denoted as $M'_1 = M_1 - D_{11}$. This leaves D_{11} available inputs, $\bar{X}_1^{(M_1 - D_{11} + 1)}, \dots, \bar{X}_1^{M_1}$ at T_1 . In Figure 2.3, 2 transmit antennas have inputs set to zero (white circles) and remaining 3 dark circles indicate the available inputs at T_1 .

Step 3: At Receiver R_1 , $D_{11} = 3$ is the dimension of desired signal received from T_1 . Hence we consider only outputs $\bar{Y}_1^1, \bar{Y}_1^2, \dots, \bar{Y}_1^{D_{11}}$ and discard remaining outputs $\bar{Y}_1^{(D_{11} + 1)}, \dots, \bar{Y}_1^{N_1}$ marked in white circles. Receiver R_1 uses D_{11} dimensions for its desired signal since its desired channel rank is D_{11} . Hence $N'_1 = N_1 - D_{11}$ is the number of tolerable interference dimensions at R_1 . Receiver

R_1 is exposed to D_{12} dimensions from the M_2 dimensional space available to Transmitter T_2 since the channel between T_2 and R_1 is of rank D_{12} . Since R_1 can tolerate only N'_1 dimensions of interference, T_2 uses only N'_1 of these D_{12} dimensions, transmitting nothing on (zero forcing) the remaining $D_{12} - N'_1$ dimensions. In addition, T_2 is free to transmit on the $M_2 - D_{12}$ dimensions that are not seen by R_1 . Thus, T_2 transmits its message using $M_2 - D_{12} + N'_1 = M_2 - (D_{11} + D_{12} - N_1)$ dimensions. Figure 2.3 illustrates such an example.

Step 4: Discarding $(D_{12} + D_{11} - N_1)$ inputs at T_2 ensures that at Receiver R_1 , interference is eliminated and R_1 can decode the message from Transmitter T_1 to achieve D_{11} DoF.

Step 5: Receiver R_2 receives interference from Transmitter T_1 over channel of rank D_{21} . In Step 2, M'_1 inputs have been set to zero, hence remaining $(D_{21} - M'_1)^+$ inputs cause interference at R_2 . In order to eliminate interference from T_1 , Receiver R_2 discards $(D_{21} - M'_1)^+$ outputs. Therefore, R_2 receives signal from T_2 only on its $N_2 - (D_{21} - M'_1)^+$ remaining outputs. In Figure 2.3, Transmitter T_1 sets $M'_1 = 2$ of its inputs to zero, and Receiver R_2 discards $(D_{21} - M'_1)^+ = 2$ outputs. R_2 decodes its signal using remaining $N_2 - (D_{21} - M'_1)^+ = 2$ outputs.

Step 6: From step 3, we have $M_2 - (D_{11} + D_{12} - N_1)$ inputs available at T_2 so that no interference is caused at R_1 . From step 5, we have $N_2 - (D_{11} + D_{21} - M_1)^+$ outputs available at R_2 that are interference-free. Channel between T_2 and R_2 is of rank D_{22} . Hence communication between T_2 and R_2 takes place with DoF of $\min(M_2 - (D_{11} + D_{12} - N_1), N_2 - (D_{11} + D_{21} - M_1)^+, D_{22})$.

Combining Steps 4 and 6, we have established achievability of $D_{11} + \min(M_2 - (D_{11} + D_{12} - N_1), N_2 - (D_{11} + D_{21} - M_1)^+, D_{22})$ total DoF for 2-user channel. This expression can be evaluated to be equal to $\min\{D_{11} + D_{22}, M_1 + N_2 - D_{21}, M_2 + N_1 - D_{12}\}$. Setting inputs or outputs to zero is equivalent to performing zero-forcing at transmitter or receiver.

2.4.2 Theorem 2.1: Proof of Outer Bound

Trivial outer bound on total DoF of $D_{11} + D_{22}$ is known for this channel. Following converse proof is similar to that of full rank channels (refer Theorem 1 in [27]), and so, we only present a proof sketch for rank-deficient channels.

For sum capacity of this channel to be bounded above by 2 constituent MAC channels, each receiver must be able to decode messages from both transmitters. For this, receiver must have access to the full interference signal space, i.e., it does not get zero-forced at the transmitters. Similar to Theorem 1 in [27], we replace the original additive noise at one receiver, say R_1 , with noise having different statistics. Note that this does not make the capacity region smaller since the original noise statistics can be obtained by locally generating and adding noise at R_1 . Hence, if R_1 was originally able to decode its intended message, it is still capable of decoding its message with modified noise statistics. In this sense, noise is modified at Receiver R_1 , if needed, so that it sees a better channel than Receiver R_2 , and message intended for Receiver R_2 becomes decodable at Receiver R_1 .

In the 2-user rank deficient MIMO interference channel, Receiver R_1 can access only a D_{12} dimensional signal space of Transmitter T_2 in its M_2 dimensional space. This implies, T_2 can zero-force part of its signal to R_1 and R_1 cannot decode message from T_2 by reducing noise. Hence only through additional antennas at R_1 can it access full signal space of T_2 . Additional receiver antennas cannot hurt, so the converse argument is not violated. To this end, we add $M_2 - D_{12}$ antennas at R_1 . Since channel coefficients corresponding to new antennas are drawn i.i.d. from a continuous distribution, interference channel between T_2 and R_1 , now a matrix of size $(N_1 + M_2 - D_{12}) \times M_2$, will be full rank. With this, R_1 can obtain a stronger channel to input of T_2 , so that if R_2 can decode the message of T_2 , so can R_1 . R_1 can locally generate noise and add to its received signal which is statistically equivalent noise signal as seen by R_2 . R_1 has less noisy channel to T_2 and can decode the message sent by T_2 . Similarly, additional antennas are added at Receiver R_2 , so that it can access full signal space of Transmitter T_1 . Interference channel between T_1 and R_2 , a

matrix of size $(N_2 + M_1 - D_{21}) \times M_1$, is full rank. With this, R_2 can obtain a stronger channel to input of T_1 , so that if R_1 can decode the message of T_1 , so can R_2 . R_2 can locally generate noise and add to its received signal which is statistically equivalent noise signal as seen by R_1 . R_2 has less noisy channel to T_1 and can decode the message sent by T_1 .

Now, we argue that the sum capacity is bounded above by corresponding MAC channels $(M_1, M_2, N_1 + M_2 - D_{12})$ and $(M_1, M_2, N_2 + M_1 - D_{21})$ with modified additive noise. Since $(N_2 + M_1 - D_{21}) \geq M_1$ and $(N_1 + M_2 - D_{12}) \geq M_2$, it can be seen that Theorem 1 in [27] holds true for above argument with N_1 modified as $N_1 + M_2 - D_{12}$ and N_2 modified as $N_2 + M_1 - D_{21}$. R_1 can decode its message and subtract from its received signal vector, and we assume a genie provides X_1 to R_2 , so that R_2 can subtract out interference from T_1 . While initial output vectors Y_1 and Y_2 are of size $(N_1 + M_2 - D_{12}) \times 1$ and $(N_2 + M_1 - D_{21}) \times 1$ respectively, after noise reduction and SVD operations, output vectors Y_{1new} and Y_{2new} are both of size $M_2 \times 1$. With these changes, R_1 and R_2 would be able to decode both messages. Hence, total DoF is upper-bounded as $\text{DoF} \leq \min(D_{11} + D_{22}, N_2 + M_1 - D_{21})$ and $\text{DoF} \leq \min(D_{11} + D_{22}, N_1 + M_2 - D_{12})$. This is because DoF expressions of 2 rank-deficient MAC channels have sum of channel ranks instead of that of number of transmit antennas. Combining these 2 bounds, we get the converse result of Theorem 2.1. ■

Remark 1: Reciprocity holds true for rank deficient channels similar to full rank channels, i.e., DoF is unaffected if M_1 and M_2 are switched with N_1 and N_2 respectively.

Remark 2: For the symmetric special case, i.e., the (M, N, D) MIMO interference channel where each transmitter has M antennas, each receiver has N antennas and all channel matrices are of rank D , optimal DoF can be calculated as $\min(M + N - D, 2D)$, which is same the achievable DoF value established by Chae et al. [15], now proved to be optimal.

2.5 3-user channel

To avoid an explosion of parameters when considering more than 2 users, we impose certain assumptions of symmetry. For the 3-user rank deficient interference channel, we assume that all transmitters and receivers have M antennas, and channels $\mathbf{H}_{(j+k)j}$ are of rank $D_k, k \in \{0, 1, 2\}$. Thus, at each receiver, the desired signal arrives through a channel of rank D_0 , interference from the ‘previous’ transmitter arrives through a channel of rank D_1 and the interference from the ‘next’ transmitter arrives through a channel of rank D_2 , where transmitter and receiver indices are circularly wrapped around modulo 3. Under this assumption of symmetry, the DoF result is presented in the following theorem.

THEOREM 2.2. *For the 3-user rank deficient MIMO interference channel with M antennas at each node, and channels $H_{(j+k)j}$ restricted to rank $D_k, j, k \in \{0, 1, 2\}$, the spatially normalized DoF value per user is given by*

$$\frac{\overline{\text{DoF}}_{\Sigma}}{3} = \min \left\{ D_0, M - \frac{\min(M, D_1 + D_2)}{2} \right\} \quad (2.6)$$

Placing the result into perspective, we note that the DoF value in Theorem 2.2 represents a strict improvement over the achievable DoF previously established by Chae et al. in [15], and matches the achievable DoF value established in parallel work by Zeng et al. in [62]. Although the results are consistent with those of [62], our achievable scheme requires atmost 2 symbol extensions while [62] involves large number of symbol extensions for the symmetric $M_T = M_R$ case. We also present a tight information theoretic outer bound that establishes the optimality of this DoF value.

The spatially normalized DoF result holds for both time-varying and constant channel coefficients. This follows similar to Theorem 1 of [55], by scaling the number of antennas by $q = 2$, when DoF is non-integer. For channel with time-varying coefficients, Theorem 2.2 is also the DoF value,

achievable with symbol extensions. Based on the spatial-scale invariance property [55], which is consistent for a wide variety of networks, we conjecture that the result is also the DoF for the 3-user rank-deficient channel with constant coefficients.

The result of Theorem 2.2 is consistent with the observation that the rank-deficiency of cross-channels does not hurt and the rank-deficiency of direct channels does not help. Since the rank-deficiency of cross-channels increases opportunities for zero-forcing and reduces the opportunities for interference alignment, it is evident that the gain from increased zero-forcing more than offsets the loss from reduced interference alignment. Compared to the full-rank case where everyone achieves half the cake, it is remarkable that half-the-cake (i.e., $M/2$ DoF per user) remains achievable as long as the direct channels support it.

We consider the setting shown in Figure 2.4.

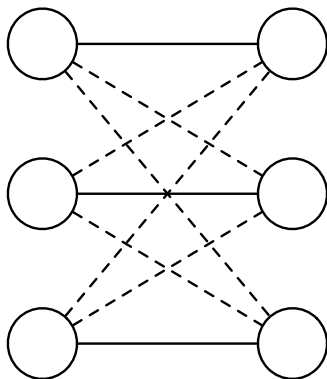

Figure 2.4: 3-user Rank Deficient Interference Channel

2.5.1 Theorem 2.2: Proof of Achievability

Achievability proof for 3-user rank deficient interference channel is first presented for cases where direct channels are full rank. Later, achievability with rank deficient direct channels is discussed.

We categorize beamforming vectors used at Transmitter k to 4 types:

\mathbf{V}_k^{Za} - Zero-forcing vectors in the nullspace of $\mathbf{H}_{(k-1)k}$, maximum number of linearly independent vectors chosen can be $M - D_1$. Vectors used at Transmitter k will not cause interference at Receiver $k - 1$.

\mathbf{V}_k^{Zb} - Zero-forcing vectors in the nullspace of $\mathbf{H}_{(k+1)k}$, maximum number of linearly independent vectors chosen can be $M - D_2$. Vectors used at Transmitter k will not cause interference at Receiver $k + 1$.

\mathbf{V}_k^{Zc} - Zero-forcing vectors in the common nullspace of $\mathbf{H}_{(k-1)k}$ and $\mathbf{H}_{(k+1)k}$ (overlapping dimensions in the 2 nullspaces). Maximum number of linearly independent vectors chosen can be $M - D_1 - D_2$ since $M - D_1$ and $M - D_2$ dimensional generic nullspaces overlap in a $M - D_1 - D_2$ dimensional space at each transmitter. Vectors chosen in these overlapping dimensions do not cause interference at either of the 2 unintended receivers.

\mathbf{V}_k^A - Alignment vectors that align signal at a receiver in the span of interference from other unintended transmitter. Maximum number of linearly independent vectors chosen can be $D_1 + D_2 - M$ since D_1 and D_2 dimensional generic interference subspaces overlap in $D_1 + D_2 - M$ dimensional space at each receiver.

Different cardinalities are chosen for these 4 types of beamforming vectors to form the transmit beamforming matrix. The beamforming matrix at each transmitter is then of the form $\mathbf{V}_k = [\mathbf{V}_k^{Za} \ \mathbf{V}_k^{Zb} \ \mathbf{V}_k^{Zc} \ \mathbf{V}_k^A]$. We now discuss achievability by analyzing the beamforming vector cardinalities listed in Table I and by using linear dimension counting arguments.

Using Table 2.1, we first analyze the setting in which direct channels are full rank and cross channels are rank deficient. First 2 cases correspond to zero-forcing based achievability schemes, and last case involves interference alignment. For convenience, only sum cardinality of the chosen zero-forcing vectors \mathbf{V}_k^{Za} and \mathbf{V}_k^{Zb} is specified, i.e., $|\mathbf{V}_k^{Za}| + |\mathbf{V}_k^{Zb}|$. This is because each of these vectors chosen at a transmitter helps in cancelling interference at one receiver but causes interference at another receiver. Since we have 2 unintended transmitters causing interference, these

Table 2.1: Achievable DoF in 3-user channel for different D_1, D_2 with $D_0 = M$

Case	$D_1 + D_2$	$ \mathbf{V}_k^{Za} + \mathbf{V}_k^{Zb} $	$ \mathbf{V}_k^{Zc} $	$ \mathbf{V}_k^A $	$dim(\text{Int})$	$dim(\text{Des})$	Total
1	$0 < D_1 + D_2 \leq M$	$\frac{D_1+D_2}{2}$	$M - (D_1 + D_2)$	0	$\frac{D_1+D_2}{2}$	$\frac{M}{2}$	M
2	$\frac{M}{3} < D_1 + D_2 \leq \frac{2M}{3}$	$\frac{M}{2}$	0	0	$\frac{M}{2}$	$\frac{M}{2}$	M
3	$\frac{2M}{3} < D_1 + D_2 \leq M$	$2M - D_1 - D_2$	0	$\frac{D_1 + D_2}{2}$	$\frac{M}{2}$	$\frac{M}{2}$	M

zero-forcing vectors can be treated in same manner. $dim(\text{Desired})$ and $dim(\text{Interference})$ are the number of desired and interference signal dimensions seen at each receiver respectively. Then we have,

$$dim(\text{Desired}) = |\mathbf{V}_k^{Za}| + |\mathbf{V}_k^{Zb}| + |\mathbf{V}_k^{Zc}| + |\mathbf{V}_k^A|$$

$$dim(\text{Interference}) = |\mathbf{V}_k^{Za}| + |\mathbf{V}_k^{Zb}| + |\mathbf{V}_k^A|$$

While the first relation is trivial, the second one can be explained as follows: \mathbf{V}_k^{Zc} at Transmitter k do not cause interference at both unintended receivers. Therefore $dim(\text{Interference})$ does not contain that term. Further, both zero-forcing (using non-overlapping nullspace) and interference alignment are similar in the sense that, vector chosen for zero-forcing one receiver causes interference at other receiver, and vector chosen for aligning interference at one receiver causes interference at another. Hence at each receiver, $dim(\text{Interference})$ is the sum of the number of zero-forcing vectors (using non-overlapping nullspace) and the number of Interference alignment vectors.

For the first case of Table I, $|\mathbf{V}_k^A| = 0$ since interference alignment is not possible ($D_1 + D_2 \leq M$). $|\mathbf{V}_k^{Zc}|$ is chosen to be the maximum possible overlapping nullspace dimensions. Remaining vectors are chosen from the non-overlapping nullspace and chosen number of vectors $|\mathbf{V}_k^{Za}| +$

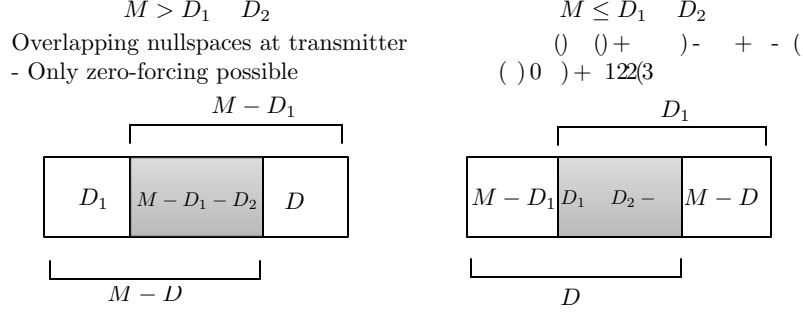

Figure 2.5: M -dimensional signal space in 3-user interference channel

$|\mathbf{V}_k^{Zb}| < D_1 + D_2$, maximum number of non-overlapping nullspace dimensions. At each receiver, interference occupies $|\mathbf{V}_k^{Za}| + |\mathbf{V}_k^{Zb}|$ dimensions.

For the second and third cases, $|\mathbf{V}_k^{Zc}| = 0$ since there are no overlapping nullspace dimensions at the transmitters ($D_1 + D_2 > M$). For case 2, though alignment is possible, beamforming matrix can be formed with the zero-forcing vectors only, i.e., $|\mathbf{V}_k^{Za}| + |\mathbf{V}_k^{Zb}|$ can be chosen as $\frac{M}{2}$. This is because $\frac{M}{2} \leq 2M - D_1 - D_2$, dimensions in the nullspaces of $\mathbf{H}_{(k-1)k}$ and $\mathbf{H}_{(k+1)k}$.

Case 3 involves both zero forcing and interference alignment. At Transmitter $k \in \{1, 2, 3\}$, $M - D_1$ symbols are sent along the $M - D_1$ dimensional null space of the channel to Receiver $k - 1$ and $M - D_2$ symbols are sent along the $M - D_2$ dimensional null space of the channel to Receiver $k + 1$. This is performed by choosing columns of a full rank linear transformation \mathbf{T}_k to be beamforming vectors \mathbf{V}_k^{Za} of size $M - D_1$ and \mathbf{V}_k^{Zb} of size $M - D_2$.

$$\mathbf{H}_{(k-1)k} \mathbf{V}_k^{Za} = 0, \quad \mathbf{H}_{(k+1)k} \mathbf{V}_k^{Zb} = 0 \quad k \in \{1, 2, 3\} \quad (2.7)$$

The remaining $D_1 + D_2 - M$ dimensional space at the transmitter will be used to send the remaining $M/2 - (M - D_1) - (M - D_2) = D_1 + D_2 - 3M/2$ symbols that participate in interference alignment. Since the cross channel matrices are rank-deficient, eigen vector solution of [9] cannot be used directly, since inverse of the matrices do not exist. Hence, one of the challenging aspects is to align

vectors using rank deficient channel matrices. We will now show that using appropriate linear transformations at the transmitters and the receivers, interference alignment can be performed.

Within the M dimensions available to Receiver k , the D_1 dimensional signal space accessible from Transmitter $k - 1$ overlaps with the D_2 dimensional signal space accessible from Transmitter $k + 1$ in a $M \times (D_1 + D_2 - M)$ dimensional subspace. If these overlapping spaces can be accessed at all the transmitters and the receivers, interference alignment can be performed. Note that at the transmitters, we consider both zero-forcing and alignment vectors to access the $M \times D_1$ or $M \times D_2$ dimensional subspaces.

At the 3 receivers, matrices $\hat{\mathbf{R}}_k, k \in \{1, 2, 3\}$ of size $M \times (D_1 + D_2 - M)$ are constructed, that represent the signal space overlap of $M \times D_1$ or $M \times D_2$ dimensional subspaces seen from Transmitter $k - 1$ and $k + 1$ respectively.

$$\hat{\mathbf{R}}_k = \mathbf{H}_{k(k-1)} \cap \mathbf{H}_{k(k+1)} \quad k \in \{1, 2, 3\} \quad (2.8)$$

wherein $A \cap B$ denotes the intersection of A and B , which can be identified as $\mathcal{N}(\mathcal{N}(A) \cup \mathcal{N}(B))$, and $\mathcal{N}(X)$ denotes the nullspace of X . Interference will be aligned in these receiver signal spaces $\hat{\mathbf{R}}_k$. These overlapping signal spaces $\hat{\mathbf{R}}_k$, are projected back to the transmitters, such that the following equations are satisfied.

$$\mathbf{H}_{(k+1)k} \tilde{\mathbf{T}}_k^1 = \hat{\mathbf{R}}_{k+1} \quad \& \quad \mathbf{H}_{(k-1)k} \tilde{\mathbf{T}}_k^2 = \hat{\mathbf{R}}_{k-1} \quad k \in \{1, 2, 3\} \quad (2.9)$$

wherein the matrices $\tilde{\mathbf{T}}_k^1, \tilde{\mathbf{T}}_k^2$ are of size $M \times (D_1 + D_2 - M)$, and do not include vectors from the nullspaces of channels $\mathbf{H}_{(k+1)k}$ and $\mathbf{H}_{(k-1)k}$, respectively. After projecting back the signal spaces, they are combined with zero-forcing vectors to identify the signal space seen from Transmitter k at the receivers $k - 1$ and $k + 1$. With this, Transmitter k has $M \times D_1$ dimensional space seen at Receiver $k + 1$ and $M \times D_2$ dimensional space seen at Receiver $k - 1$, which overlap in a

$M \times (D_1 + D_2 - M)$ dimensional space, denoted as $\hat{\mathbf{T}}_k$.

$$\hat{\mathbf{T}}_k = [\tilde{\mathbf{T}}_k^1 \quad \mathbf{V}_k^{Zb}] \cap [\tilde{\mathbf{T}}_k^2 \quad \mathbf{V}_k^{Za}] \quad k \in \{1, 2, 3\} \quad (2.10)$$

In order to align interference, above $M \times (D_1 + D_2 - M)$ submatrix, $\hat{\mathbf{T}}_k$ will be constructed, such that the same space is seen at both unintended receivers $k - 1$ and $k + 1$. Linear transformations $\hat{\mathbf{T}}_k, \hat{\mathbf{R}}_k$ represent the signal space overlap at the transmitters and the receivers, identification of which enables us to perform one-one alignment of vectors, as follows.

Transmitter k uses the following $M \times M$ linear transformation \mathbf{T}_k using the signal space overlap matrix, $\hat{\mathbf{T}}_k$ and zero-forcing vectors.

$$\mathbf{T}_k = \begin{bmatrix} \mathbf{V}_k^{Za} & \hat{\mathbf{T}}_k & \mathbf{V}_k^{Zb} \end{bmatrix} \quad k \in \{1, 2, 3\} \quad (2.11)$$

Receiver k sees $M - D_1$ dimensional interference from Transmitter $k - 1$ and $M - D_2$ dimensional interference from Transmitter $k + 1$. These $(M - D_1) + (M - D_2)$ interference symbols are zero-forced by projecting the M dimensional received space into the $M - (M - D_1) - (M - D_2)$ dimensional space that is orthogonal to the interference symbols. This is performed using full-rank linear transformation \mathbf{R}_k of size $(D_1 + D_2 - M) \times M$ at Receiver k .

$$\mathbf{R}_k [\mathbf{H}_{k(k-1)} \mathbf{V}_{k-1}^{Za} \quad \mathbf{H}_{k(k+1)} \mathbf{V}_{k+1}^{Zb}] = 0, \quad k \in \{1, 2, 3\} \quad (2.12)$$

With this, residual interference at Receiver k due to zero-forcing beamforming vectors chosen at all transmitters are zero-forced. For the remaining symbols, i.e., for the remaining interference alignment problem, the zero forcing operations at the transmitters and receivers, described thus far leave us with a 3-user MIMO interference channel with $D_1 + D_2 - M$ input dimensions at each transmitter and $D_1 + D_2 - M$ dimensions at each receiver, with the following channel matrices.

This is illustrated in Figure 2.6.

$$\bar{\mathbf{H}}_{kj} = \mathbf{R}_k \mathbf{H}_{kj} \mathbf{T}_j \quad (2.13)$$

We have constructed $\bar{\mathbf{H}}'_{ji}$ by considering $D_1 + D_2 - M$ columns of matrix $\bar{\mathbf{H}}_{ji}$ after excluding first $M - D_1$ and last $M - D_2$ columns. Since $D_1 + D_2 - M$ is not larger than D_1, D_2 , these channels are full rank, generic channels over which the eigenvectors-based interference alignment solution of [9] can be directly applied to send the remaining $D_1 + D_2 - 3M/2$ symbols (Note that 2 channel uses are needed for the aligned symbols if M is an odd number, each corresponding to a new set of zero-forcing symbols). Thus, the effective receiver sees a $D_1 + D_2 - M$ dimensional generic space within which $D_1 + D_2 - 3M/2$ aligned interference dimensions and $(M - D_1) + (M - D_2) + (D_1 + D_2 - 3M/2)$ desired dimensions are resolved.

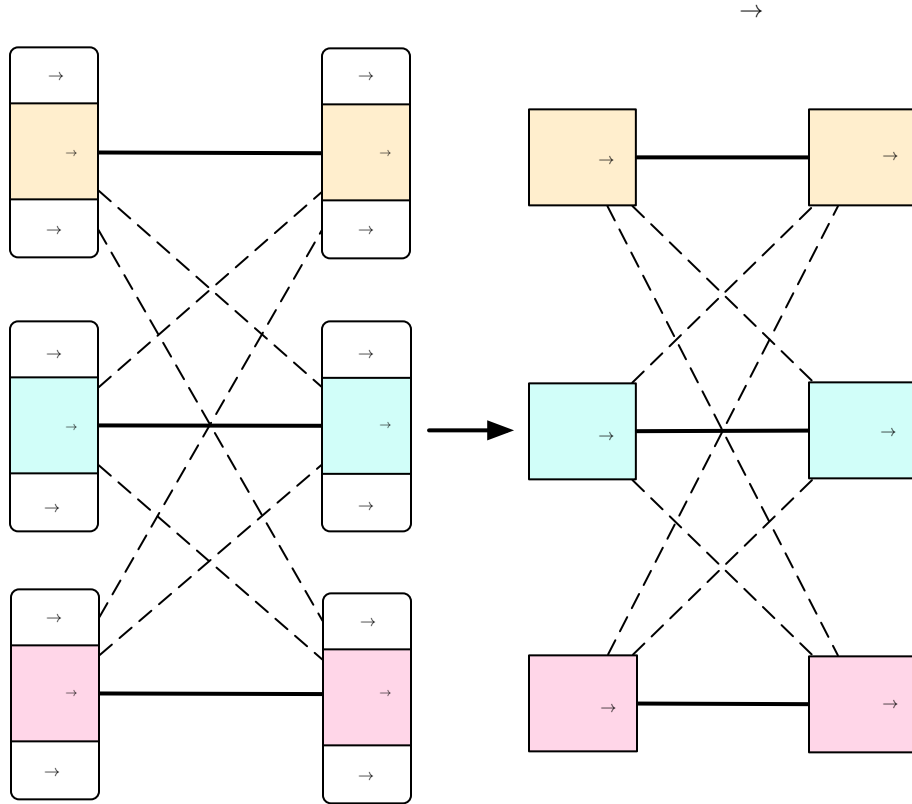

Figure 2.6: Alignment in 3-user interference channel

The beamforming matrices $\bar{\mathbf{V}}_k$ have $(M - D_1) + (M - D_2)$ columns of the identity matrix, shown on the leftmost and the rightmost column in the example below. Remaining columns of $\bar{\mathbf{V}}_k$ are based on the eigen-vector solution of dimension $D_1 + D_2 - M$ and rows of zeros above and below. Suppose $M = 6$ and $D_1 = D_2 = 5$, $\bar{\mathbf{V}}_k$ constructed with 2 zero-forcing vectors and 1 alignment vector, have the following structure.

$$\bar{\mathbf{V}}_k = \begin{bmatrix} 1 & 0 & 0 \\ 0 & v_{k1}^a & 0 \\ 0 & v_{k2}^a & 0 \\ 0 & v_{k3}^a & 0 \\ 0 & v_{k4}^a & 0 \\ 0 & 0 & 1 \end{bmatrix}$$

wherein $\bar{\mathbf{V}}_k^A = [v_{k1}^a \ v_{k2}^a \ v_{k3}^a \ v_{k4}^a]^T$ is the interference alignment vector constructed as in [9], which is then extended with $M - D_1$ rows of zeros above and $M - D_2$ rows of zeros below to form \mathbf{V}_k^A . Due to the construction of \mathbf{T}_k using the signal space overlap $\hat{\mathbf{T}}_k$, vectors $\bar{\mathbf{V}}_k^A$ align one-one at the receivers. The resultant beamforming matrix \mathbf{V}_k used at Transmitter k is then

$$\mathbf{V}_k = \mathbf{T}_k \bar{\mathbf{V}}_k = [\mathbf{V}_k^{Za} \ \mathbf{V}_k^A \ \mathbf{V}_k^{Zb}] \quad (2.14)$$

Linear transformations at all transmitters and receivers $\mathbf{T}_k, \mathbf{R}_k$ are full rank matrices based on construction described. It can be noted that matrices $\bar{\mathbf{V}}_k$ and \mathbf{V}_k are full rank since columns are linearly independent due to orthogonal construction of $\bar{\mathbf{V}}_k$. Note that desired channels are not used in the design of precoding vectors, which maintains their generic character and thereby the linear independence of desired signal vectors from the interference. We also note that a similar layered precoding approach is presented in [62] as well.

When direct channels are rank deficient, no more than D_0 vectors can be used for beamforming. For all values of D_0 such that $D_0 \geq M - \frac{\min(M, D_1 + D_2)}{2}$, same DoF can be obtained as in Table I by choosing specified number of beamforming vectors. When $D_0 < M - \frac{\min(M, D_1 + D_2)}{2}$, we send only D_0 beamforming vectors corresponding to all 3 cases, choosing first the zero-forcing vectors and then the alignment vectors as needed. In all cases, $\dim(\text{Interference}) + \dim(\text{Desired}) \leq M$ since both desired and interference dimensions reduce with these changes.

Combining the DoF results for the 3 cases of Table I, achievability of $\min(D_0, M - \frac{\min(M, D_1 + D_2)}{2})$ DoF per user has been proved. ■

2.5.2 Theorem 2.2: Proof of Outer Bound

Converse proofs are described separately for two cases: $D_1 + D_2 > M$ and $D_1 + D_2 \leq M$. For both cases, we first present the change of basis operations similar to [55], and then discuss the genie-aided outer bounds. We first present a lemma which is used for proving the outer bounds.

Lemma 1. *For the K -user rank deficient interference channel, if a genie provides a subset of the noisy transmitted signals, denoted as \mathcal{G} , to Receiver k , such that it can decode all K messages from the observation (Y_k^n, \mathcal{G}) , then we can always outer bound the mutual information term $I(W_1, W_2, \dots, W_K; Y_k^n, \mathcal{G})$ as follows:*

$$I(W_1, W_2, \dots, W_K; Y_k^n, \mathcal{G}) = I(W_1, W_2, \dots, W_K; Y_k^n) + I(W_1, W_2, \dots, W_K; \mathcal{G} | Y_k^n) \quad (2.15)$$

$$\leq Mn \log \rho + I(W_1, W_2, \dots, W_K; \mathcal{G} | Y_k^n) + n o(\log \rho) \quad (2.16)$$

$$\leq Mn \log \rho + h(\mathcal{G} | Y_k^n) h(\mathcal{G} | W_1, W_2, \dots, W_K, Y_k^n) + n o(\log \rho) \quad (2.17)$$

$$= Mn \log \rho + h(\mathcal{G} | Y_k^n) + n o(\log \rho) + o(n) \quad (2.18)$$

Proof: In the derivations above, (2.15) follows from the mutual information chain rule. (2.16) is obtained because Receiver k has only M antennas. (2.17) follows from the entropy chain rule, and (2.18) is obtained from Lemma 3 since given all K messages, we can reconstruct the genie signals \mathcal{G} subject to noise distortion.

Outer bound when $D_1 + D_2 > M$

Change of Basis:

Step 1: For each receiver, a linear transformation \mathbf{R}_k is designed such that the first $M - D_2$ antennas of Receiver k do not hear Transmitter $k - 1$ (left nullspace of $\mathbf{H}_{k(k-1)}$) and the last $M - D_1$ antennas of Receiver k do not hear Transmitter $k + 1$ (left nullspace of $\mathbf{H}_{k(k+1)}$). Corresponding signals seen at Receiver k are denoted as S_{ka} and S_{kc} , respectively. This is possible since $\text{rank}(\mathbf{H}_{k(k+1)})=D_1$ and $\text{rank}(\mathbf{H}_{k(k-1)})=D_2$.

Step 2: In the M -dimensional space at Transmitter k , there is a D_1 -dimensional subspace orthogonal to $M - D_1$ receiver antennas $(k - 1)a$ and D_2 -dimensional subspace orthogonal to $M - D_2$ receiver antennas $(k + 1)c$. These two subspaces overlap in $I = D_1 + D_2 - M$ dimensions within the M -dimensional space seen by the transmitter, and these I columns are chosen for matrix \mathbf{T}_k at the transmitter, and the signal transmitted is denoted as X_{kb} . Other columns of \mathbf{T}_k are chosen such that the first $M - D_2$ antennas of Transmitter k are not heard by Receiver $k + 1$ (right nullspace of $\mathbf{H}_{k(k-1)}$) and the last $M - D_1$ antennas of Transmitter k are not heard by Receiver $k - 1$ (right nullspace of $\mathbf{H}_{k(k+1)}$). Corresponding signals sent by Transmitter k are denoted as X_{ka} and X_{kc} , respectively.

Step 3: Remaining $D_1 + D_2 - M$ rows for linear transformation \mathbf{R}_k are chosen so that they are linearly independent of other rows. Corresponding received signal is denoted as S_{kb} . Resulting network connectivity is shown in Figure 2.7.

Outer bound proof:

	$ X = M \rightarrow D$			$S(X)$		$ S = M \rightarrow D$
$ X = D + D \rightarrow M > 0$				$S(X, X, X, X)$		$ S = D + D \rightarrow M > 0$
	$ X = M \rightarrow D$			$S(X)$		$ S = M \rightarrow D$

	$ X = M \rightarrow D$			$S(X)$		$ S = M \rightarrow D$
$ X = D + D \rightarrow M > 0$				$S(X, X, X, X)$		$ S = D + D \rightarrow M > 0$
	$ X = M \rightarrow D$			$S(X)$		$ S = M \rightarrow D$

	$ X = M \rightarrow D$			$S(X)$		$ S = M \rightarrow D$
$ X = D + D \rightarrow M > 0$				$S(X, X, X, X)$		$ S = D + D \rightarrow M > 0$
	$ X = M \rightarrow D$			$S(X)$		$ S = M \rightarrow D$

Figure 2.7: Basis change for 3-user channel: $D_1 + D_2 > M$

Desired signal is assumed to be decodable and can be removed. Genie information to be given to Receiver 1 should include $2M - (D_1 + D_2)$ dimensions - X_{2c}^n, X_{3a}^n which are not heard by receiver 1. Receiver 1 has M equations with $D_1 + D_2$ unknowns. Hence only if genie information includes another $D_1 + D_2 - M$ dimensions, then at Receiver 1, there will be M equations resolvable using M unknowns.

Hence a genie provides $\mathcal{G}_1 = \{X_{2b}^n, X_{2c}^n, X_{3a}^n\}$ to Receiver 1. Number of dimensions available to Receiver 1 is $M + |\mathcal{G}_1| = 2M$. With $2M$ dimensions, Receiver 1 will be able to resolve both interfering signals and can decode all three messages. Over n channel uses, sum rate can be bounded as follows.

$$nR_\Sigma \leq Mn \log \rho + h(X_{2b}^n, X_{2c}^n, X_{3a}^n | \bar{Y}_1^n) + n o(\log \rho) + o(n) \quad (2.19)$$

$$\leq Mn \log \rho + h(X_{3a}^n | \bar{Y}_1^n) + h(X_{2b}^n | \bar{Y}_1^n) + h(X_{2c}^n | \bar{Y}_1^n, X_{2b}^n, X_{3a}^n) + n o(\log \rho) + o(n) \quad (2.20)$$

$$\leq Mn \log \rho + h(X_{3a}^n) + h(X_{2b}^n | X_{2a}^n) + h(X_{2c}^n | X_{2a}^n, X_{2b}^n) + n o(\log \rho) + o(n) \quad (2.21)$$

$$= Mn \log \rho + h(X_{3a}^n) + nR_2 - h(X_{2a}^n) + n o(\log \rho) + o(n) \quad (2.22)$$

where (2.19) follows from Fano's inequality and Lemma 1. (2.20) follows from applying the chain rule. (2.21) follows since dropping condition terms cannot decrease differential entropy. Thus, we only keep S_{1a}^n as the condition term which is X_{2a}^n . (2.22) is obtained because from the observations of $(X_{2a}^n, X_{2b}^n, X_{2c}^n)$ we can decode W_2 subject to the noise distortion. By advancing user indices, we have:

$$3nR \leq Mn \log \rho + nR + n o(\log \rho) + o(n) \quad (2.23)$$

which implies that $d \leq \frac{M}{2}$. Since D_0 is a known outer bound, we get $\frac{\text{DoF}}{K} \leq \min(D_0, \frac{M}{2})$.

Outer bound when $D_1 + D_2 \leq M$

Change of Basis:

Step 1: For each receiver, a linear transformation \mathbf{R}_k is designed such that the first D_1 antennas of Receiver k do not hear Transmitter $k - 1$ (left nullspace of $\mathbf{H}_{k(k-1)}$) and the last D_2 antennas of Receiver k do not hear Transmitter $k + 1$ (left nullspace of $\mathbf{H}_{k(k+1)}$). Corresponding signals seen at Receiver k are denoted as S_{ka} and S_{kc} , respectively. This is possible since $\text{rank}(\mathbf{H}_{k(k+1)})=D_1$ and $\text{rank}(\mathbf{H}_{k(k-1)})=D_2$.

Step 2: In the M -dimensional space at Transmitter k , there is a $M - D_1$ dimensional subspace orthogonal to D_1 receiver antennas $(k - 1)a$ and another $M - D_2$ dimensional subspace orthogonal to D_2 receiver antennas $(k + 1)c$. These two subspaces have $I = M - (D_1 + D_2)$ dimensional intersection at the transmitter, wherein I columns are chosen for matrix \mathbf{T}_k , and the signal transmitted is denoted as X_{kb} . Then, we choose other columns of \mathbf{T}_k such that D_1 antennas of Transmitter k are not heard by Receiver $k + 1$ (right nullspace of $\mathbf{H}_{k(k-1)}$) and D_2 antennas of Transmitter k are not heard by Receiver $k - 1$ (right nullspace of $\mathbf{H}_{k(k+1)}$). Corresponding signals sent by Transmitter k are denoted as X_{ka} and X_{kc} , respectively.

Step 3: We consider only $D_1 + D_2$ antennas at each receiver, remaining antennas are discarded since no signal is received (denoted as S_{kb}). Resulting network connectivity is shown in Figure 2.8.

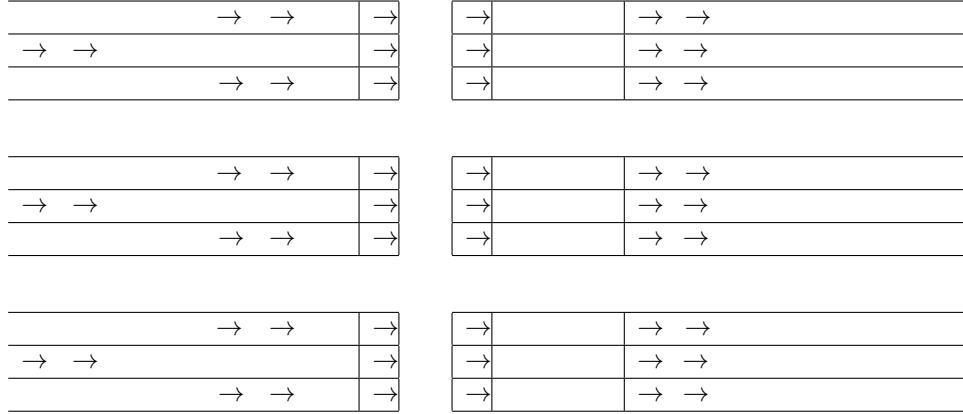

Figure 2.8: Basis change for 3-user channel: $D_1 + D_2 \leq M$

Outer bound proof:

Desired signal is assumed to be decodable and can be removed. Genie information to be given to Receiver 1 should include $2M - (D_1 + D_2)$ dimensions - $X_{2b}^n, X_{2c}^n, X_{3a}^n, X_{3b}^n$ which are not heard by Receiver 1. Receiver 1 has M equations with $D_1 + D_2$ unknowns. Since $D_1 + D_2 < M$, choosing signal from only $D_1 + D_2$ antennas results in $D_1 + D_2$ equations becoming resolvable.

Hence a genie provides $\mathcal{G}_1 = \{X_{2b}^n, X_{2c}^n, X_{3a}^n, X_{3b}^n\}$ to Receiver 1. Since Receiver 1 considers only $D_1 + D_2$ antennas, number of dimensions available to Receiver 1 is $D_1 + D_2 + |\mathcal{G}_1| = 2M$. With $2M$ dimensions, Receiver 1 will be able to resolve both interfering signals and can decode all three

messages.

$$nR_\Sigma \leq Mn \log \rho + h(X_{2b}^n, X_{2c}^n, X_{3a}^n, X_{3b}^n | \bar{Y}_1^n) + no(\log \rho) + o(n) \quad (2.24)$$

$$\leq Mn \log \rho + h(X_{3a}^n | \bar{Y}_1^n) + h(X_{3b}^n | \bar{Y}_1^n) + h(X_{2b}^n, X_{2c}^n | \bar{Y}_1^n, X_{3a}^n, X_{3b}^n) + no(\log \rho) + o(n) \quad (2.25)$$

$$\leq Mn \log \rho + h(X_{3a}^n) + h(X_{3b}^n) + h(X_{2b}^n, X_{2c}^n | X_{2a}^n) + no(\log \rho) + o(n) \quad (2.26)$$

$$= Mn \log \rho + h(X_{3a}^n) + h(X_{3b}^n) + nR_2 - h(X_{2a}^n) + no(\log \rho) + o(n) \quad (2.27)$$

$$\leq (2M - (D_1 + D_2))n \log \rho + h(X_{3a}^n) + nR_2 - h(X_{2a}^n) + no(\log \rho) + o(n) \quad (2.28)$$

where (2.24) follows from Fano's inequality and Lemma 1. (2.25) follows from applying the chain rule. (2.26) follows since dropping condition terms cannot decrease differential entropy. Thus, we only keep S_{1a}^n as the condition term which is X_{2a}^n . (2.27) is obtained because from the observations of $(X_{2a}^n, X_{2b}^n, X_{2c}^n)$ we can decode W_2 subject to the noise distortion, (2.28) follows since the entropy of X_{3b}^n is constrained by $M - (D_1 + D_2)$ antennas. By advancing user indices:

$$3nR \leq (2M - (D_1 + D_2))n \log \rho + nR + no(\log \rho) + o(n) \quad (2.29)$$

which implies that $d \leq \frac{2M - (D_1 + D_2)}{2}$. Since D_0 is known outer bound, we get $\frac{\text{DoF}}{K} \leq \min(D_0, M - \frac{D_1 + D_2}{2})$. Converse result of Theorem 2.2 follows from two cases described above. ■

2.6 K -user channel

For the K -user rank deficient interference channel, we assume all transmitters and receivers have M antennas, all direct channels have rank D_0 and all cross channels have rank D . The DoF result is presented in the following theorem for time-varying channels.

THEOREM 2.3. For the K -user rank deficient MIMO interference channel with M antennas at each node, where the direct channels have rank D_0 , cross channels have rank D with time-varying channel coefficients, the DoF value per user is given by

$$\frac{\text{DoF}_\Sigma}{K} = \min \left\{ D_0, M - \frac{\min(M, (K-1)D)}{2} \right\} \quad (2.30)$$

Similar to the 3-user rank deficient interference channel, we note that for the K -user rank deficient interference channel, the rank-deficiency of direct channels does not help and the rank-deficiency of cross-channels does not hurt. Half-the-cake remains achievable as long as the direct channels support it.

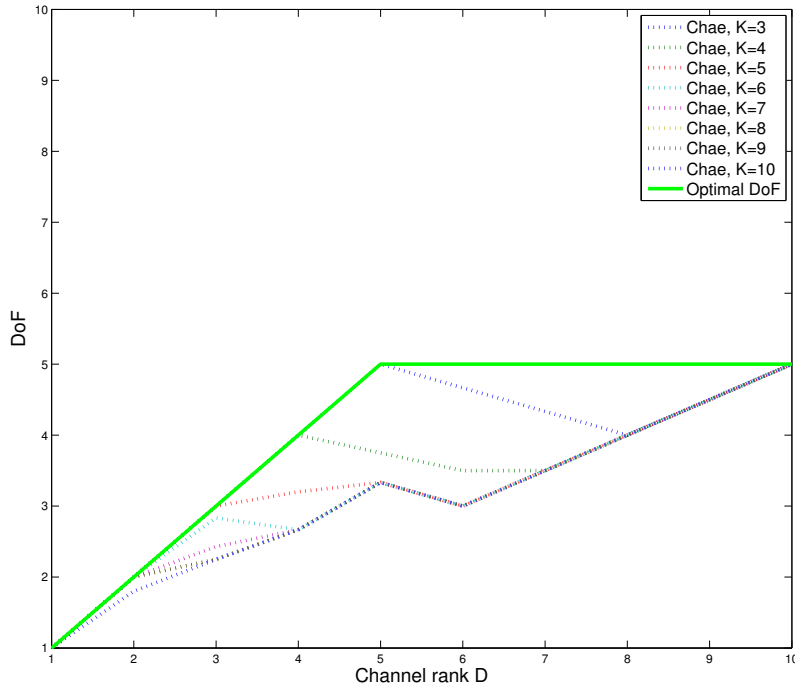

Figure 2.9: DoF of K -user Rank Deficient Interference Channel with $M = 10$: Comparison with result of Chae at al. in [15]

In Figure 2.9, the optimal DoF value presented in Theorem 2.3 are compared with the achievable DoF established by Chae et al. in [15], assuming that each node has $M = 10$ antennas and all direct and cross channels are of rank D . The green line corresponds to the optimal DoF while various dotted lines represent achievable DoF of [15] for different K . It can be noted that for this setting, optimal DoF per user being $\min(D, \frac{M}{2})$ indicates that there is no DoF loss as number of users (K) increases, which is not true for the result in [15].

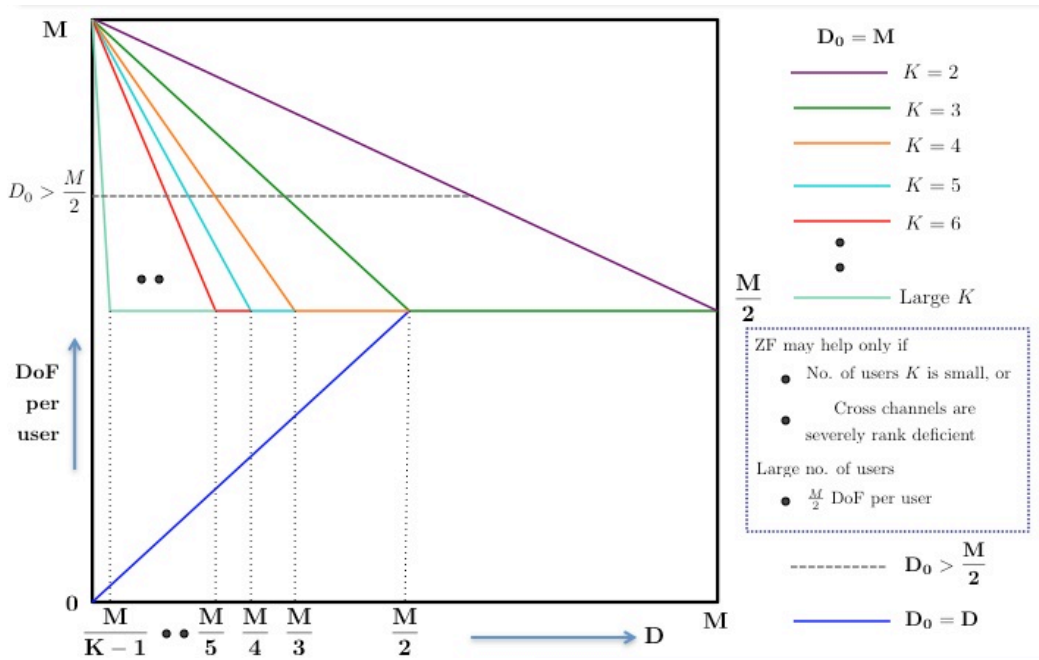

Figure 2.10: DoF of K -user Rank Deficient Interference Channel

In Figure 2.10, optimal DoF per user are plotted against the cross channel rank D . When the direct channels are full rank, there are significant DoF gains above $\frac{M}{2}$ due to zero-forcing. Zero-forcing helps improve DoF either if the number of users, K , is small or if the cross channels are severely rank deficient. As the number of users, K , become large, DoF becomes $\frac{M}{2}$ for almost all cross channel ranks.

While the nature of the DoF result remains consistent across rank-deficient 2-user, 3-user and K -user MIMO settings, the increasing complexity of achievable schemes requires increasingly

sophisticated arguments to counter channel dependencies. The details of these arguments as well as the corresponding outer bounds are provided in the remainder of this work.

2.6.1 Alignment with Spatial dependencies

When all MIMO channels are full rank, K -user MIMO channel can simply be decomposed to a KM user SISO interference channel as shown in Figure 2.11. However, in the presence of rank deficiencies, there are spatial dependencies between some of the channels, due to which decomposition of the channel does not benefit and CJ scheme cannot be used directly. Hence, we perform one-sided decomposition of antennas at the transmitters, as in [51], while allowing joint processing at the receivers. We first discuss the CJ scheme tailored for channels with spatial dependencies and show that the DoF can be made arbitrarily close to half per user. Then we use the presented scheme for the K -user rank deficient channel with one-sided decomposition, to establish achievable DoF.

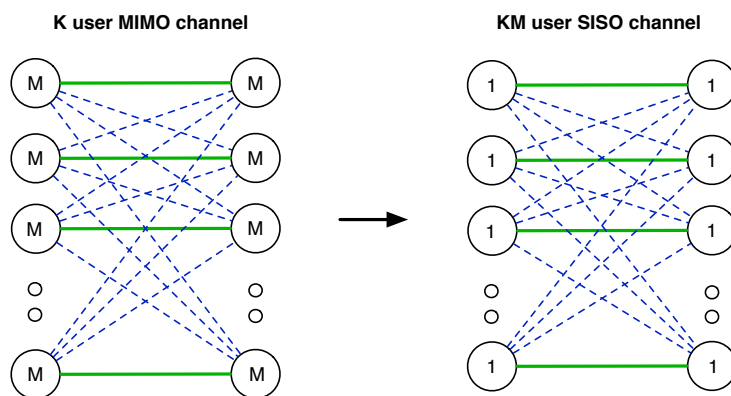

Figure 2.11: K -user interference channel: Decomposition

Let us consider the CJ scheme for K -user SISO channel $M_k = N_k = 1, k \in \{1, \dots, K\}$, with symbol extended channel over n channel uses, such that all channel matrices \mathbf{H}_{ji} are diagonal. We consider physical channels wherein the spatial dependencies do not change over time. Therefore, a spatial dependency which relates a set of channels, through an expression involving few

generic channel variables, holds for all realizations of those generic channel variables. We denote the $N = K(K - 1)$ linear transformations corresponding to the cross channels $\mathbf{H}_{ji}, i \neq j$ as $\mathbf{T}_1, \mathbf{T}_2, \dots, \mathbf{T}_N$. Due to presence of rank deficient channels in the original network, there could be spatial dependencies between few of the cross channels. This could result in precoding matrix \mathbf{V}_n not being full rank. In this section, we will show that spatial dependencies involving cross channels do not affect the achievable DoF adversely.

Interference Alignment

Let us denote the precoding matrix used at each transmitter in the original scheme as \mathbf{V}_n , and that used at each transmitter in presence of spatial dependencies by $\bar{\mathbf{V}}$ or $\bar{\mathbf{V}}_n$. Similar to construction in [26], we construct a precoding matrix $\bar{\mathbf{V}}$ such that it is invariant to the scaling factors $\mathbf{T}_1, \mathbf{T}_2, \dots, \mathbf{T}_N$. Note that the commutative property of linear transformations \mathbf{T}_i holds even in presence of spatial dependencies, which is necessary for aligning interference. This is because all \mathbf{T}_i are diagonal channels resulting from symbol extensions.

We will now construct the precoding matrix $\bar{\mathbf{V}}_n$ by just removing dependent columns of \mathbf{V}_n . Similar to $\bar{\mathbf{V}}_n, \mathbf{V}_n$, we will use $\bar{\mathcal{I}}_n, \mathcal{I}_n$ to denote interference space at the receivers, with and without linearly dependent columns removed, respectively. Similar to [26], all transmitters use the same set of signaling vectors $\bar{\mathbf{V}}_n$ and all receivers approximately set aside the same subspace $\bar{\mathcal{I}}_n$ for interference.

$$\mathbf{V}_n = \left\{ (\mathbf{T}_1)^{\alpha_1} (\mathbf{T}_2)^{\alpha_2} \dots (\mathbf{T}_N)^{\alpha_N} \mathbf{1} \quad \text{s.t.} \quad \sum_{i=1}^N \alpha_i \leq n, \quad \alpha_1, \alpha_2, \dots, \alpha_N \in \mathbb{Z}_+ \cup \{0\} \right\}$$

$$\bar{\mathbf{V}}_n = \text{Linearly independent columns of } \mathbf{V}_n \text{ (Reordered)} \quad (2.31)$$

wherein $\mathbf{1}$ refers to all-one column vector, and we choose $\mathcal{I}_n = \mathbf{V}_{n+1}$, and $\bar{\mathcal{I}}_n = \bar{\mathbf{V}}_{n+1}$.

In order to choose linearly independent columns, we first impose a lexicographic order on the columns of \mathbf{V}_n and \mathcal{I}_n , similar to that in [51]. All columns are arranged from left to right in increasing order of α_1 . Then columns corresponding to same order of α_1 are arranged in increasing order of α_2 , and so on till α_N . This ordering has the property that a tuple $(\alpha_1, \alpha_2, \dots, \alpha_N)$ appears before the tuple $(\beta_1, \beta_2, \dots, \beta_N)$, if and only if the first α_i , which is different from β_i , is smaller than β_i . After reordering the columns in \mathbf{V}_n and \mathcal{I}_n , each column is added sequentially starting from left to right, to $\bar{\mathbf{V}}_n$ and $\bar{\mathcal{I}}_n$, only if they are linearly independent with the columns that have been added already, in $\bar{\mathbf{V}}_n$ and $\bar{\mathcal{I}}_n$. Note that above reordering is only an exemplary choice for choosing linearly independent columns, and other choices exist.

Since we have removed only the dependent columns from $\mathbf{V}_n, \mathcal{I}_n$ to form $\bar{\mathbf{V}}_n, \bar{\mathcal{I}}_n$, the column spans of the precoding matrices remain the same.

$$\text{span}(\bar{\mathbf{V}}_n) = \text{span}(\mathbf{V}_n) \quad (2.32)$$

$$\text{span}(\bar{\mathcal{I}}_n) = \text{span}(\mathcal{I}_n) \quad (2.33)$$

Construction of precoding matrices $\mathbf{V}_n, \mathcal{I}_n$ similar to that in [9, 26] ensures that

$$\text{span}(\mathbf{T}_i \mathbf{V}_n) \subseteq \text{span}(\mathcal{I}_n) \quad (2.34)$$

$$\text{span}(\mathbf{T}_i \bar{\mathbf{V}}_n) = \text{span}(\mathbf{T}_i \mathbf{V}_n) \quad (2.35)$$

Thus, we have aligned interference from all unintended transmitters at the receivers in space $\bar{\mathcal{I}}_n$,

$$\text{span}(\mathbf{T}_i \bar{\mathbf{V}}_n) = \text{span}(\mathbf{T}_i \mathbf{V}_n) \subseteq \text{span}(\mathcal{I}_n) = \text{span}(\bar{\mathcal{I}}_n) \quad (2.36)$$

In the original construction, number of precoding vectors was given by $|\mathbf{V}_n| = \binom{n+N}{N}$ and $|\mathcal{I}_n| = \binom{n+N+1}{N}$. While we do not specify the number of precoding vectors in $\bar{\mathbf{V}}_n, \bar{\mathcal{I}}_n$, we know that $|\bar{\mathbf{V}}_n| < |\bar{\mathcal{I}}_n| = |\bar{\mathbf{V}}_{n+1}|$.

We have so far shown that all interference signals align in the span of $\bar{\mathcal{I}}_n$ at the receivers, in the presence of spatial dependencies. Note that this is possible because we assume all spatial dependencies to involve only the cross channels. Now we will show that desired and interference signal spaces can occupy half the dimensions each at all receivers, almost surely.

Half the cake

In following proofs, we use limit infimum as defined below, since for sequences whose convergence is not guaranteed, limits may not exist. Also, sequences considered are bounded, since the number of columns in precoding matrices are finite.

Definition: Limit infimum

The limit infimum (\liminf) of a sequence x_n is the largest real number b that, for any positive real number ϵ , there exists a natural number N such that $x_n > b - \epsilon$ for all $n > N$.

Property: For sequence x_n , if $a > \liminf x_n$, then there is an infinite subsequence x_{n_k} of x_n such that $a > x_{n_k} \forall k$.

Lemma 2. For the K -user interference channel with spatial dependencies, and precoding matrices with linearly independent columns, denoted as $\bar{\mathbf{V}}_n$ and $\bar{\mathcal{I}}_n = \bar{\mathbf{V}}_{n+1}$,

$$i. \liminf_{n \rightarrow \infty} \frac{|\bar{\mathbf{V}}_{n+1}| - |\bar{\mathbf{V}}_n|}{|\bar{\mathbf{V}}_n|} = 0 \quad (2.37)$$

$$ii. \text{There exist a subsequence of } n \text{ such that } \frac{|\bar{\mathbf{V}}_n|}{|\bar{\mathbf{V}}_n| + |\bar{\mathcal{I}}_n|} \text{ can be made arbitrarily close to } \frac{1}{2} \quad (2.38)$$

Proof: i. We will prove this by contradiction. Suppose the contrary is true, i.e., there exists a positive number $\epsilon > 0$ such that

$$\liminf_{n \rightarrow \infty} \frac{|\bar{\mathbf{V}}_{n+1}| - |\bar{\mathbf{V}}_n|}{|\bar{\mathbf{V}}_n|} > \epsilon \quad (2.39)$$

which can be written as

$$\liminf_{n \rightarrow \infty} \frac{|\bar{\mathbf{V}}_{n+1}|}{|\bar{\mathbf{V}}_n|} > (1 + \epsilon) \quad (2.40)$$

Considering the definition of limit infimum, above relation implies that there exists a positive integer n_0 such that for all $n > n_0$, following holds.

$$\frac{|\bar{\mathbf{V}}_{n+1}|}{|\bar{\mathbf{V}}_{n_0}|} > (1 + \epsilon)^{n+1-n_0} \quad (2.41)$$

Above is a recursive relation that holds for all positive integers n . Therefore we deduce

$$|\bar{\mathbf{V}}_n| > (1 + \epsilon)^{n-n_0} |\bar{\mathbf{V}}_{n_0}| \quad (2.42)$$

Based on construction of precoding vectors in the CJ scheme, we know that

$$|\bar{\mathbf{V}}_{n+1}| \leq \binom{n+N+1}{N} \quad (2.43)$$

Hence, we have the following

$$\frac{|\bar{\mathbf{V}}_{n+1}|}{|\bar{\mathbf{V}}_n|} \leq \frac{\binom{n+N+1}{N}}{(1 + \epsilon)^{n-n_0} |\bar{\mathbf{V}}_{n_0}|} \quad (2.44)$$

It can be seen that for large n , term on right goes to zero since it is a ratio of a polynomial over an exponential in n . However, this cannot be true since $|\bar{\mathbf{V}}_n| \leq |\bar{\mathbf{V}}_{n+1}|$, leading to a contradiction.

Hence the assumption in (2.39) cannot hold, and we have proved (2.37), i.e., growth rate of size of precoding matrix after removing the dependent columns, reaches zero asymptotically for large n . In other words, $\bar{\mathbf{V}}_{n+1}$ and $\bar{\mathbf{V}}_n$ are “almost” of the same size.

ii. From i., note that

$$\liminf_{n \rightarrow \infty} \frac{|\bar{\mathbf{V}}_{n+1}|}{|\bar{\mathbf{V}}_n|} = 1 \quad (2.45)$$

Also, for sequence x_n , if $a > \liminf x_n$, then there is an infinite subsequence x_{n_k} of x_n such that $a > x_{n_k} \forall k$. Using this, we can choose n, δ such that following holds

$$\frac{|\bar{\mathbf{V}}_{n+1}|}{|\bar{\mathbf{V}}_n|} < 1 + \delta \quad (2.46)$$

From above relation, we can deduce the best value of

$$\frac{|\bar{\mathbf{V}}_n|}{|\bar{\mathbf{V}}_n| + |\bar{\mathcal{I}}_n|} = \frac{|\bar{\mathbf{V}}_n|}{|\bar{\mathbf{V}}_{n+1}| + |\bar{\mathbf{V}}_n|} \approx \frac{1}{1 + (1 + \delta)} = \frac{1}{2 + \delta} \quad (2.47)$$

Hence with appropriate choice for δ , ratio of desired signal dimensions and total signal dimensions can be made arbitrarily close to $\frac{1}{2}$ for large n . ■

We will now use above lemma to show achievable DoF for K -user rank deficient interference channel.

2.6.2 Theorem 2.3: Proof of Achievability

Achievability proofs for K -user rank deficient channel with time-varying channel coefficients, are presented separately for two regions -

- Sum of cross channel ranks, $(K - 1)D \leq \text{Number of antennas, } M$

- Sum of cross channel ranks, $(K - 1)D > \text{Number of antennas, } M$

Achievable scheme involves only zero-forcing when $(K - 1)D \leq M$ (Region 1) and CJ scheme with one-sided decomposition is involved when $(K - 1)D > M$ (Region 2).

Region 1: Interference spans part of the receiver signal space: $(K - 1)D \leq M$

We will first consider all direct channels to be full rank, and show that zero-forcing is sufficient to achieve DoF of $M - \frac{(K-1)D}{2}$ per user.

Since all cross channels are of rank D , common nullspace of all cross channels at each transmitter has $M - (K - 1)D$ dimensions. Hence, each transmitter can choose $M - (K - 1)D$ zero-forcing beamforming vectors from the common nullspace such that these vectors do not cause interference at any of the $K - 1$ unintended receivers. For example, Transmitter 1 chooses $M - (K - 1)D$ vectors from the following nullspace so that no interference is caused at the receivers $2, 3, \dots, K$.

$$\text{null}([\mathbf{H}_{21} \ \mathbf{H}_{31} \ \cdots \ \mathbf{H}_{K1}])$$

Additionally, $\frac{(K-1)D}{2}$ vectors can be chosen from the common nullspaces of $K - 2$ cross channels. This is possible because apart from $M - (K - 1)D$ dimensions already chosen, there are $(K - 1)D$ dimensions in the set of common nullspaces of $K - 2$ cross channels at each transmitter. For example, Transmitter 1 chooses $\frac{(K-1)D}{2}$ vectors, with $\frac{D}{2}$ vectors from each of the following nullspaces.

$$\begin{aligned} & \text{null}([\mathbf{H}_{31} \ \mathbf{H}_{41} \ \cdots \ \mathbf{H}_{K1}]) \\ & \text{null}([\mathbf{H}_{21} \ \mathbf{H}_{41} \ \cdots \ \mathbf{H}_{K1}]) \\ & \quad \vdots \\ & \text{null}([\mathbf{H}_{21} \ \mathbf{H}_{31} \ \cdots \ \mathbf{H}_{(K-1)1}]) \end{aligned}$$

$(K - 1)D = 6 < M$. 4 beamforming vectors can be chosen from common nullspace of all 3 cross channels at each transmitter, denoted as NS_k . Another 3 dimensions are chosen at Transmitter 1 as follows : Common nullspace of channels $\mathbf{H}_{21}, \mathbf{H}_{31}$ has 2 dimensions (vectors linearly independent from 4 chosen earlier), and we choose one vector from this space. Common nullspace of channels $\mathbf{H}_{31}, \mathbf{H}_{41}$ has 2 dimensions, and we choose one vector from this space. Common nullspace of channels $\mathbf{H}_{21}, \mathbf{H}_{41}$ has 2 dimensions, and we choose one vector from this space. Similarly 3 vectors can be chosen at transmitters 2, 3, 4 from corresponding common nullspaces. Hence at each transmitter, we choose 4 beamforming vectors such that they will not cause interference at any receiver, and 3 beamforming vectors are chosen so that each receiver sees only 3-dimensional interference. Hence desired signal occupying 7 dimensions is resolvable from 3-dimensional interference at all receivers. When D is odd, 2 symbol extensions of the channel are considered to achieve DoF of $M - \frac{(K-1)D}{2}$.

Note that the above result holds for other direct channel ranks when $D_0 \geq M - \frac{(K-1)D}{2}$. When direct channels are of rank $D_0 < M - \frac{(K-1)D}{2}$, it can be shown that D_0 DoF per user are achievable. Hence for the region $(K - 1)D \leq M$, $\min\left(D_0, M - \frac{(K-1)D}{2}\right)$ DoF per user are achievable.

Region 2: Interference spans the full receiver signal space: $(K - 1)D > M$

Ergodic Interference Alignment

For the region $(K - 1)D > M$, we first discuss the achievable scheme through ergodic interference alignment with time-varying channel coefficients, similar to the scheme in [29]. All symbols are repeated by the K transmitters over 2 channel uses t_1 and t_2 , where all cross-channels remain the same $\mathbf{H}_{ji}(t_1) = \mathbf{H}_{ji}(t_2), i \neq j$, but all direct channels are different $\mathbf{H}_{ii}(t_1) \neq \mathbf{H}_{ii}(t_2)$. All receivers subtract the symbols received at channel use t_1 from the symbols received at channel use t_2 . Interference is eliminated since it was the same during both channel uses t_1 and t_2 . Desired signals remain because direct channels changed into new generic channels between the 2 channel

uses. Note that the ranks of the cross channels do not impact this achievable scheme. Thus, M independent equations in M desired variables are obtained over 2 channel uses, achieving $\frac{M}{2}$ DoF per user, when direct channel rank $D_0 \geq \frac{M}{2}$. This scheme is similar to coding over a channel matrix and its complement, like in ergodic interference alignment of [41], but is more general since there are no assumptions on the channel phase. It is straightforward to extend the scheme to other direct channel ranks, i.e., when $D_0 < \frac{M}{2}$, and show that achievable DoF per user is $\min(D_0, \frac{M}{2})$.

While the ergodic interference alignment scheme helps in establishing DoF of the rank deficient channel, it does so only for channel coefficients exhibiting the ergodic nature, which stem from the requirement for all cross channel coefficients to repeat. Hence, we avoid making such restrictive assumptions and consider channels without the ergodic nature, since in practice, channel fading distribution could change over time. With this premise, henceforth, we prove the same DoF result using asymptotic interference alignment (CJ) scheme. Further, asymptotic schemes often serve as stepping stones to translate DoF results obtained for time-varying channels to constant channels, using real alignment schemes, as described in [40, 61].

Asymptotic Interference Alignment

We now discuss CJ scheme over symbol extended channel with time-varying channel coefficients, by performing decomposition of antennas only at the transmitters (i.e., no joint processing) for the region $(K - 1)D > M$. The idea of one-sided decomposability was earlier used by Sun et al. in [51] for X channel to prove linear independence of desired and interfering signals at the receivers. From Section 2.6.1, we infer that the precoding matrix $\bar{\mathbf{V}}_n$ could be made full rank, by discarding the linearly dependent columns of \mathbf{V}_n . Also, Lemma 2 implies that the ratio of desired signal dimensions over total signaling dimensions can be made arbitrarily close to $\frac{1}{2}$, after discarding the linearly dependent columns.

To establish achievable DoF, we also need to show that the desired and interfering signals are linearly independent at all receivers, i.e., we need to show $[\mathbf{H}_{kk}\bar{\mathbf{V}}_n \quad \mathbf{H}_{kj}\bar{\mathbf{V}}_n]$ is full rank for all

$k, j \in \{1, \dots, KM\}, j \neq k$ wherein \mathbf{H}_{kj} represents the channel between Transmitter j and Receiver k . Decomposition of antennas at all nodes would not help if direct channels are rank deficient, since there are dependencies between the direct and the cross channels. Hence, we perform one-sided decomposition of the channel, wherein we treat antennas of each transmitter node separately while allowing joint processing at the receivers. We first consider all direct channels to be of rank $D_0 \geq \frac{M}{2}$, and show that DoF of $\frac{M}{2}$ per user can be achieved. When $D_0 < \frac{M}{2}$, it can be shown that DoF of D_0 per user can be achieved, establishing that the achievable DoF per user is $\min(D_0, \frac{M}{2})$ for the region $(K-1)D > M$. We describe the proofs for even M , and symbol extensions are used if necessary, for odd M or other cases.

Let us consider the K -user rank deficient interference channel wherein all direct channels are of rank $D_0 \geq \frac{M}{2}$. With one-sided decomposition of the channel, there are MK transmitters each with single antenna, sending messages to K receivers each with M antennas. Consider n symbol extension of the original channel so that each transmitter sees an n -dimensional signal space while each receiver has nM dimensional signal space. The value of n will be specified later. The input-output relationship of the symbol-extended channel is

$$Y^{[j]}(\kappa) = \sum_{i=1}^{MK} \mathbf{H}^{[ji]}(\kappa) X^{[i]}(\kappa) + Z^{[j]}(\kappa) = \sum_{i=1}^{MK} \begin{bmatrix} \tilde{\mathbf{H}}_1^{[ji]}(\kappa) \\ \vdots \\ \tilde{\mathbf{H}}_M^{[ji]}(\kappa) \end{bmatrix} X^{[i]}(\kappa) + Z^{[j]}(\kappa), \quad j \in \{1, 2, \dots, K\}$$

where $X^{[i]}(\kappa) \in \mathbb{C}^{n \times 1}$ is the signal vector sent by the i^{th} transmitter and $Y^{[j]}(\kappa) \in \mathbb{C}^{nM \times 1}$ is the received signal vector at Receiver j over extended channel-use index κ . $\tilde{\mathbf{H}}_m^{[ji]}(\kappa) \in \mathbb{C}^{n \times n}$ represents the diagonal channel matrix from Transmitter i to the m^{th} receive antenna of Receiver

j where $m \in \{1, \dots, M\}$, i.e.,

$$\tilde{\mathbf{H}}_m^{[ji]}(\kappa) = \begin{bmatrix} H_m^{[ji]}(n(\kappa-1)+1) & 0 & \dots & 0 \\ 0 & H_m^{[ji]}(n(\kappa-1)+2) & \dots & 0 \\ \vdots & \dots & \ddots & \vdots \\ 0 & 0 & \dots & H_m^{[ji]}(n\kappa) \end{bmatrix}. \quad (2.48)$$

The channel-use index is suppressed for compactness. Each transmitter selects the same beamforming matrix \mathbf{V} to precode its message for Receiver $j \in \{1, \dots, K\}$. Specifically, $\mathbf{X}^{[i]} = \mathbf{V}\mathbf{x}^{[i]}$, $i \in \{1, \dots, MK\}$, where \mathbf{V} is the $n \times \binom{n+N}{N}$ precoding matrix and $\mathbf{x}^{[i]}$ is the $|\mathbf{V}| \times 1$ data stream vector from Transmitter i . In order to consolidate the interference caused by \mathbf{V} at all receivers $j \in \{1, \dots, K\}$ as much as possible, we set the interference space brought by \mathbf{V} at receivers $1, \dots, K$ to roughly $\underbrace{\mathbf{V} \times \dots \times \mathbf{V}}_{M \text{ times}}$, in which interference will be aligned

$$\text{span} \left[\tilde{\mathbf{H}}^{[ji]} \mathbf{V} \right] = \text{span} \begin{bmatrix} \tilde{\mathbf{H}}_1^{[ji]} \mathbf{V} \\ \tilde{\mathbf{H}}_2^{[ji]} \mathbf{V} \\ \vdots \\ \tilde{\mathbf{H}}_M^{[ji]} \mathbf{V} \end{bmatrix} \approx \text{span} \begin{bmatrix} \mathbf{V} & \mathbf{0} & \dots & \mathbf{0} \\ \mathbf{0} & \mathbf{V} & \dots & \mathbf{0} \\ \vdots & \vdots & \ddots & \vdots \\ \mathbf{0} & \mathbf{0} & \dots & \mathbf{V} \end{bmatrix}_{nM \times |\mathbf{V}|M} \quad (2.49)$$

$i \in \{1, \dots, MK\}, j \in \{1, \dots, K\}, j \neq \lfloor \frac{i-1}{M} \rfloor + 1$

All of the above conditions can be written as

$$\mathbf{V} \approx \tilde{\mathbf{H}}_m^{[ji]} \mathbf{V}, \quad i \in \{1, \dots, MK\}, j \in \{1, \dots, K\}, \quad j \neq \lfloor \frac{i-1}{M} \rfloor + 1, m \in \{1, \dots, M\} \quad (2.50)$$

where \approx, \approx are used to denote that \mathbf{V} is approximately invariant to the scaling factors $\tilde{\mathbf{H}}_m^{[ji]}$. To paraphrase, messages for Receiver j are sent along the same signal space \mathbf{V} and aligned into $\mathbf{V} \times \dots \times \mathbf{V}$ space at all receivers $l \in \{1, \dots, j-1, j+1, \dots, K\}$.

Let us define $\mathcal{I} = \text{span} \left(\bigcup_{i,l,m} \text{span}(\tilde{\mathbf{H}}_m^{[li]} \mathbf{V}) \right)$, which is the span of union of interference terms caused by \mathbf{V} on antenna m at all receivers other than the intended receiver, and condition (2.50) becomes $\mathbf{V} \approx \mathcal{I}$ which essentially states that \mathbf{V} scales invariantly by the interference-carrying links. It can be satisfied simultaneously with the CJ scheme using beamforming vectors:

$$\mathbf{V} = \left\{ \left(\prod_{i,j,m} (\tilde{\mathbf{H}}_m^{[ji]})^{\alpha_m^{[ji]}} \right) \mathbf{1}, \text{ s. t. } \sum_{i,j,m} \alpha_m^{[ji]} \leq n, \alpha_m^{[ji]} \in \{0\} \cup \mathbb{Z}_+, \right. \\ \left. i \in \{1, \dots, MK\}, j \in \{1, \dots, K\}, j \neq \lfloor \frac{i-1}{M} \rfloor + 1, m \in \{1, \dots, M\} \right\} \quad (2.51)$$

$$\mathcal{I} = \left\{ \left(\prod_{i,j,m} (\tilde{\mathbf{H}}_m^{[ji]})^{\alpha_m^{[ji]}} \right) \mathbf{1}, \text{ s. t. } \sum_{i,j,m} \alpha_m^{[ji]} \leq n + 1, \alpha_m^{[ji]} \in \{0\} \cup \mathbb{Z}_+, \right. \\ \left. i \in \{1, \dots, MK\}, j \in \{1, \dots, K\}, j \neq \lfloor \frac{i-1}{M} \rfloor + 1, m \in \{1, \dots, M\} \right\} \quad (2.52)$$

where $\mathbf{1}$ is the $n \times 1$ all ones column vector.

Thus \mathbf{V} contains product terms up to degree n and interference term \mathcal{I} contains product terms up to degree $n+1$. Note that the original network had rank deficient channels which introduces spatial dependencies, however, we discard all linearly dependent columns of \mathbf{V} and \mathcal{I} after reordering the columns in a lexicographic order, as discussed in Section 2.6.1. We represent the resultant matrices after discarding all linearly dependent columns, as $\bar{\mathbf{V}}$ and $\bar{\mathcal{I}}$. Unlike in Section 2.6.1, some of the cross channels are not included in the construction of precoding matrix above, which is beneficial for the linear independence proofs. However, this does not violate the result of Lemma 2.

At each receiver, desired signals occupy $M|\bar{\mathbf{V}}|$ dimensions and aligned interference occupies $M|\bar{\mathcal{I}}|$ dimensions. To accommodate both desired signals and interference, the size of receive signal space, nM , should be as big as the sum of the dimensions of desired signals and interference. Therefore, we set $nM = M|\bar{\mathbf{V}}| + M|\bar{\mathcal{I}}|$, i.e., $n = |\bar{\mathbf{V}}| + |\bar{\mathcal{I}}|$. To ensure decodability, we should guarantee the linear independence of the desired signals from interference.

Due to symmetry, we only prove linear independence of signals at Receiver 1. Let us define

$$\mathbf{D}_m^{[1]} = \begin{bmatrix} \tilde{\mathbf{H}}_m^{[11]} \bar{\mathbf{V}} & \tilde{\mathbf{H}}_m^{[12]} \bar{\mathbf{V}} & \dots & \tilde{\mathbf{H}}_m^{[1M]} \bar{\mathbf{V}} \end{bmatrix}, \quad m \in \{1, \dots, M\} \quad (2.53)$$

which corresponds to the desired signal at the m^{th} antenna of Receiver 1. Then the desired signal at Receiver 1 correspond to the columns of $\mathbf{D}^{[1]}$.

$$\mathbf{D}^{[1]} = \begin{bmatrix} \mathbf{D}_1^{[1]} \\ \mathbf{D}_2^{[1]} \\ \vdots \\ \mathbf{D}_M^{[1]} \end{bmatrix} = \begin{bmatrix} \tilde{\mathbf{H}}_1^{[11]} \bar{\mathbf{V}} & \tilde{\mathbf{H}}_1^{[12]} \bar{\mathbf{V}} & \dots & \tilde{\mathbf{H}}_1^{[1M]} \bar{\mathbf{V}} \\ \tilde{\mathbf{H}}_2^{[11]} \bar{\mathbf{V}} & \tilde{\mathbf{H}}_2^{[12]} \bar{\mathbf{V}} & \dots & \tilde{\mathbf{H}}_2^{[1M]} \bar{\mathbf{V}} \\ \vdots & \vdots & & \vdots \\ \tilde{\mathbf{H}}_M^{[11]} \bar{\mathbf{V}} & \tilde{\mathbf{H}}_M^{[12]} \bar{\mathbf{V}} & \dots & \tilde{\mathbf{H}}_M^{[1M]} \bar{\mathbf{V}} \end{bmatrix} \quad (2.54)$$

At Receiver 1, interference from transmitters $j \in \{2, \dots, K\}$, are aligned in the column span of

$$\mathbf{E}^{[1]} = \begin{bmatrix} \bar{\mathcal{I}} & \mathbf{0} & \dots & \mathbf{0} \\ \mathbf{0} & \bar{\mathcal{I}} & \dots & \mathbf{0} \\ \vdots & \vdots & \ddots & \vdots \\ \mathbf{0} & \mathbf{0} & \dots & \bar{\mathcal{I}} \end{bmatrix} = \mathbf{I}_M \otimes \bar{\mathcal{I}} \quad (2.55)$$

We need to show that the $nM \times nM$ matrix $\mathbf{F}^{[1]} = [\mathbf{D}^{[1]} \ \mathbf{E}^{[1]}]$ has full rank almost surely. We will first show that the desired signals are linearly independent among themselves and then prove that the desired signal space does not overlap with the interference space.

Step 1: We first prove that the desired signals are linearly independent, i.e., the $nM \times |\bar{\mathbf{V}}|M$ matrix $\mathbf{D}^{[1]}$ has full rank, almost surely. To do this, it is sufficient to prove the following $M|\bar{\mathbf{V}}| \times M|\bar{\mathbf{V}}|$ submatrix of $\mathbf{D}^{[1]}$ is full rank.

$$\bar{\mathbf{D}}^{[1]} = \begin{bmatrix} \bar{\mathbf{D}}_a^{[1]} \\ \bar{\mathbf{D}}_b^{[1]} \end{bmatrix}_{M|\bar{\mathbf{V}}| \times M|\bar{\mathbf{V}}|} \quad (2.56)$$

where

$$\bar{\mathbf{D}}_a^{[1]} \text{ has the top } |\bar{\mathbf{V}}| \text{ rows of each } \mathbf{D}_m^{[1]}, m \in \{1, \dots, \frac{M}{2}\} \quad (2.57)$$

$$\bar{\mathbf{D}}_b^{[1]} \text{ has the bottom } |\bar{\mathbf{V}}| \text{ rows of each } \mathbf{D}_m^{[1]}, m \in \{\frac{M}{2} + 1, \dots, M\} \quad (2.58)$$

and so, $\bar{\mathbf{D}}^{[1]}$ can be written as

$$\bar{\mathbf{D}}^{[1]} = \begin{bmatrix} \tilde{\mathbf{H}}_{1a}^{[11]} \bar{\mathbf{V}}_a & \tilde{\mathbf{H}}_{1a}^{[12]} \bar{\mathbf{V}}_a & \cdots & \tilde{\mathbf{H}}_{1a}^{[1M]} \bar{\mathbf{V}}_a \\ \vdots & \vdots & & \vdots \\ \tilde{\mathbf{H}}_{\frac{M}{2}a}^{[11]} \bar{\mathbf{V}}_a & \tilde{\mathbf{H}}_{\frac{M}{2}a}^{[12]} \bar{\mathbf{V}}_a & \cdots & \tilde{\mathbf{H}}_{\frac{M}{2}a}^{[1M]} \bar{\mathbf{V}}_a \\ \tilde{\mathbf{H}}_{(\frac{M}{2}+1)b}^{[11]} \bar{\mathbf{V}}_b & \tilde{\mathbf{H}}_{(\frac{M}{2}+1)b}^{[12]} \bar{\mathbf{V}}_b & \cdots & \tilde{\mathbf{H}}_{(\frac{M}{2}+1)b}^{[1M]} \bar{\mathbf{V}}_b \\ \vdots & \vdots & & \vdots \\ \tilde{\mathbf{H}}_{Mb}^{[11]} \bar{\mathbf{V}}_b & \tilde{\mathbf{H}}_{Mb}^{[12]} \bar{\mathbf{V}}_b & \cdots & \tilde{\mathbf{H}}_{Mb}^{[1M]} \bar{\mathbf{V}}_b \end{bmatrix} \quad (2.59)$$

wherein $\tilde{\mathbf{H}}_{ma}^{[1i]}$ is a diagonal square matrix of dimension $|\bar{\mathbf{V}}| \times |\bar{\mathbf{V}}|$ obtained from the first $|\bar{\mathbf{V}}|$ rows and columns of matrix $\mathbf{H}_m^{[1i]}$, $\tilde{\mathbf{H}}_{mb}^{[1i]}$ is a diagonal square matrix of dimension $|\bar{\mathbf{V}}| \times |\bar{\mathbf{V}}|$ obtained from the last $|\bar{\mathbf{V}}|$ rows and columns of matrix $\mathbf{H}_m^{[1i]}$. $\bar{\mathbf{V}}_a$ is the $|\bar{\mathbf{V}}| \times |\bar{\mathbf{V}}|$ matrix obtained from the first $|\bar{\mathbf{V}}|$ rows of matrix $\bar{\mathbf{V}}$ and $\bar{\mathbf{V}}_b$ is the $|\bar{\mathbf{V}}| \times |\bar{\mathbf{V}}|$ matrix obtained from the last $|\bar{\mathbf{V}}|$ rows of matrix $\bar{\mathbf{V}}$. Note that $\bar{\mathbf{D}}^{[1]}$ has $M|\bar{\mathbf{V}}|$ rows corresponding to M receiver antennas and $M|\bar{\mathbf{V}}|$ columns corresponding to the desired signals from M transmitters.

We will prove that $\det(\bar{\mathbf{D}}^{[1]}) \neq 0$ almost surely. The determinant of the matrix $\bar{\mathbf{D}}^{[1]}$ is a polynomial function of its entries. This polynomial is either identically a zero polynomial i.e., zero for all realizations, such as $x - x$, or it is not identically a zero polynomial, i.e., there exist some realizations for which the polynomial takes non-zero values. If a polynomial is not identically a zero polynomial, then it is not equal to zero almost surely for randomly generated channel coefficients, see e.g., the Schwartz Zippel Lemma [47, 63, 53]. Therefore, in order to show that a polynomial is almost surely non-zero for random realizations it suffices to show that it is not identically a zero-

polynomial, i.e., that it is non-zero for at least one realization. So we show that the polynomial is not a zero polynomial by finding one specific set of channel coefficients such that the polynomial is not equal to zero.

We will set the channel coefficients such that $\bar{\mathbf{D}}^{[1]}$ becomes a block diagonal matrix with M full rank blocks, which implies that $\bar{\mathbf{D}}^{[1]}$ is full rank, almost surely.

$$\bar{\mathbf{D}}^{[1]} = \begin{bmatrix} \tilde{\mathbf{H}}_{1a}^{[11]} \bar{\mathbf{V}}_a & \cdots & 0 & \cdots & 0 \\ \vdots & \ddots & \vdots & \ddots & \vdots \\ 0 & \cdots & \tilde{\mathbf{H}}_{\frac{M}{2}a}^{[1\frac{M}{2}]} \bar{\mathbf{V}}_a & \cdots & 0 \\ \vdots & \ddots & \vdots & \ddots & \vdots \\ 0 & \cdots & 0 & \cdots & \tilde{\mathbf{H}}_{Mb}^{[1M]} \bar{\mathbf{V}}_b \end{bmatrix} \quad (2.60)$$

$\bar{\mathbf{D}}^{[1]}$ corresponds to the desired signal from transmitters $1, \dots, M$ to Receiver 1. We set all rows except rows $(i-1)|\bar{\mathbf{V}}|+1, \dots, i|\bar{\mathbf{V}}|$ of $\bar{\mathbf{D}}^{[1]}$ to zero by choosing corresponding channel coefficients in the matrices $\bar{\mathbf{H}}_{ma}^{[1k]}, \bar{\mathbf{H}}_{mb}^{[1k]}, m \neq k$ to zero. Choosing these channel coefficients to be zero does not violate the rank constraints in the original network since $D_0 \geq \frac{M}{2}$. It is for this reason that we choose top $|\bar{\mathbf{V}}|$ rows for first $\frac{M}{2}$ antennas and last $|\bar{\mathbf{V}}|$ rows for last $\frac{M}{2}$ antennas, corresponding to different timeslots. Note that this can be done because $\bar{\mathbf{V}}$ does not contain the desired channel coefficients associated with Receiver 1. We have converted $\bar{\mathbf{D}}^{[1]}$ into a block diagonal matrix wherein each block is of size $|\bar{\mathbf{V}}| \times |\bar{\mathbf{V}}|$. We now show that each block is full rank almost surely. From the construction of $\bar{\mathbf{V}}_a$ and $\bar{\mathbf{V}}_b$, note that they are full rank matrices since linearly dependent columns have been discarded in $\bar{\mathbf{V}}$, as in Section 2.6.1, and various rows correspond to cross channel coefficients of different timeslots. Further, since $\bar{\mathbf{H}}_m^{[1i]}, m \in \{1, \dots, M\}$ are all full rank diagonal matrices with elements independent of $\bar{\mathbf{V}}_a$ and $\bar{\mathbf{V}}_b$, and so, each block matrix is full rank. Therefore, the desired signal matrix $\bar{\mathbf{D}}^{[1]}$ is full rank almost surely. Similarly, it can be shown that desired signal matrices $\bar{\mathbf{D}}^{[k]}$ are full rank, almost surely, at other receivers $k \in \{2, \dots, K\}$.

Step 2: We will now prove that the interference space does not overlap with the desired signal space at the receivers. To this end, we first reorder the rows of matrix $\mathbf{F}^{[1]} = [\mathbf{D}^{[1]} \ \mathbf{E}^{[1]}]$, arranging them according to the channel use slots. Desired signal received at channel index κ is given by

$$\mathbf{D}^{[1]}(\kappa) = \begin{bmatrix} H_1^{[11]}(\kappa) & H_1^{[12]}(\kappa) & \cdots & H_1^{[1M]}(\kappa) \\ H_2^{[11]}(\kappa) & H_2^{[12]}(\kappa) & \cdots & H_2^{[1M]}(\kappa) \\ \vdots & \vdots & \vdots & \vdots \\ H_M^{[11]}(\kappa) & H_M^{[12]}(\kappa) & \cdots & H_M^{[1M]}(\kappa) \end{bmatrix} \otimes \bar{\mathbf{V}}(\kappa, :) \quad (2.61)$$

At Receiver 1, interference caused by signals intended for receivers $j = 2, \dots, K$ at channel index κ , is given as

$$\mathbf{E}^{[1]}(\kappa) = \mathbf{I}_M \otimes \bar{\mathbf{I}}(\kappa, :) \quad (2.62)$$

As a result, signals received at channel use index κ is

$$\mathbf{F}^{[1]}(\kappa) = \begin{bmatrix} \mathbf{D}^{[1]}(\kappa) & \mathbf{E}^{[1]}(\kappa) \end{bmatrix} \quad (2.63)$$

After rearranging the rows of $\mathbf{F}^{[1]}$ as above, it can be written as

$$\mathbf{F}^{[1]} = \begin{bmatrix} \mathbf{F}^{[1]}(1) \\ \vdots \\ \mathbf{F}^{[1]}(n) \end{bmatrix} \quad (2.64)$$

We now describe the proofs for the matrix $\mathbf{F}^{[1]}$ containing desired and interference signals being full rank, first for $M = 2$, followed by that for arbitrary M .

A. Linear independence proof for $M = 2$

Consider the signal space at Receiver 1, represented by matrix $\mathbf{F}^{[1]}$ of size $2n \times 2n$, wherein $n = |\bar{\mathbf{V}}| + |\bar{\mathcal{I}}|$. In this matrix, the first $2|\bar{\mathbf{V}}|$ columns correspond to the desired signal, and the last $2|\bar{\mathcal{I}}|$ columns correspond to the interference signal.

$$\mathbf{F}^{[1]} = \begin{bmatrix} \mathbf{D}^{[1]} & \mathbf{E}^{[1]} \end{bmatrix}_{2n \times 2n} \quad (2.65)$$

wherein the columns corresponding to the desired signals are represented using $\mathbf{D}^{[1]}$

$$\mathbf{D}^{[1]} = \begin{bmatrix} \mathbf{D}^{[1]}(1) \\ \mathbf{D}^{[1]}(2) \\ \vdots \\ \mathbf{D}^{[1]}(n) \end{bmatrix}_{2n \times 2|\bar{\mathbf{V}}|} \quad (2.66)$$

$$\mathbf{D}^{[1]}(\kappa) = \mathbf{H}_{11}(\kappa) \otimes \bar{\mathbf{V}}(\kappa, :) = \begin{bmatrix} \bar{\mathbf{H}}_1^{[11]}(\kappa) \bar{\mathbf{V}}(\kappa, :) & \bar{\mathbf{H}}_1^{[12]}(\kappa) \bar{\mathbf{V}}(\kappa, :) \\ \bar{\mathbf{H}}_2^{[11]}(\kappa) \bar{\mathbf{V}}(\kappa, :) & \bar{\mathbf{H}}_2^{[12]}(\kappa) \bar{\mathbf{V}}(\kappa, :) \end{bmatrix}_{2 \times 2|\bar{\mathbf{V}}|} \quad (2.67)$$

and the columns corresponding to the interference signals are represented using $\mathbf{E}^{[1]}$

$$\mathbf{E}^{[1]} = \begin{bmatrix} \bar{\mathcal{I}}(1,1) & \bar{\mathcal{I}}(1,2) & \cdots & \bar{\mathcal{I}}(1,|\bar{\mathcal{I}}|) & 0 & 0 & \cdots & 0 \\ 0 & 0 & \cdots & 0 & \bar{\mathcal{I}}(1,1) & \bar{\mathcal{I}}(1,2) & \cdots & \bar{\mathcal{I}}(1,|\bar{\mathcal{I}}|) \\ \bar{\mathcal{I}}(2,1) & \bar{\mathcal{I}}(2,2) & \cdots & \bar{\mathcal{I}}(2,|\bar{\mathcal{I}}|) & 0 & 0 & \cdots & 0 \\ 0 & 0 & \cdots & 0 & \bar{\mathcal{I}}(2,1) & \bar{\mathcal{I}}(2,2) & \cdots & \bar{\mathcal{I}}(2,|\bar{\mathcal{I}}|) \\ \vdots & \vdots & \vdots & \vdots & \vdots & \vdots & \vdots & \vdots \\ \bar{\mathcal{I}}(|\bar{\mathbf{V}}|,1) & \bar{\mathcal{I}}(|\bar{\mathbf{V}}|,2) & \cdots & \bar{\mathcal{I}}(|\bar{\mathbf{V}}|,|\bar{\mathcal{I}}|) & 0 & 0 & \cdots & 0 \\ 0 & \cdots & 0 & 0 & \bar{\mathcal{I}}(|\bar{\mathbf{V}}|,1) & \bar{\mathcal{I}}(|\bar{\mathbf{V}}|,2) & \cdots & \bar{\mathcal{I}}(|\bar{\mathbf{V}}|,|\bar{\mathcal{I}}|) \\ \vdots & \vdots & \vdots & \vdots & \vdots & \vdots & \vdots & \vdots \\ \bar{\mathcal{I}}(n,1) & \bar{\mathcal{I}}(n,2) & \cdots & \bar{\mathcal{I}}(n,|\bar{\mathcal{I}}|) & 0 & 0 & \cdots & 0 \\ 0 & \cdots & 0 & 0 & \bar{\mathcal{I}}(n,1) & \bar{\mathcal{I}}(n,2) & \cdots & \bar{\mathcal{I}}(n,|\bar{\mathcal{I}}|) \end{bmatrix}_{2n \times 2|\bar{\mathcal{I}}|} \quad (2.68)$$

where $\bar{\mathbf{V}}(\kappa, :)$ denotes κ -th row of $\bar{\mathbf{V}}$, and $\bar{\mathcal{I}}(k, l)$ denotes the element in the k -th row and l -th column of $\bar{\mathcal{I}}$. Note that 2 consecutive rows correspond to same timeslot, and signals correspond to n timeslots.

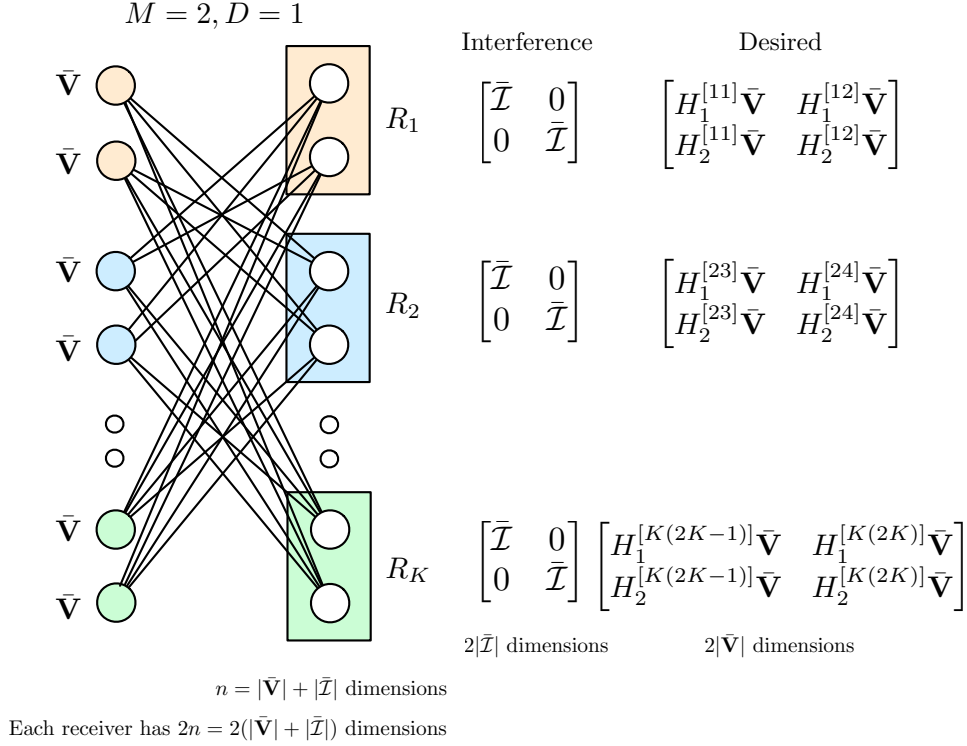

Figure 2.13: Asymptotic alignment for K -user rank deficient channel with $M = 2$

Suppose the 2×2 direct channel between Transmitter 1 and Receiver 1 is of rank 1, then without loss of generality, the desired signal matrix corresponding to channel use index κ , $\mathbf{D}^{[1]}(\kappa)$ can be written as

$$\mathbf{D}^{[1]}(\kappa) = \mathbf{H}_{11}(\kappa) \otimes \bar{\mathbf{V}}(\kappa, :) = \begin{bmatrix} \bar{\mathbf{H}}_1^{[11]}(\kappa) \bar{\mathbf{V}}(\kappa, :) & \bar{\mathbf{H}}_1^{[12]}(\kappa) \bar{\mathbf{V}}(\kappa, :) \\ \alpha_\kappa \bar{\mathbf{H}}_1^{[11]}(\kappa) \bar{\mathbf{V}}(\kappa, :) & \alpha_\kappa \bar{\mathbf{H}}_1^{[12]}(\kappa) \bar{\mathbf{V}}(\kappa, :) \end{bmatrix}_{2 \times 2|\bar{\mathbf{V}}|} \quad (2.69)$$

We will now show that the determinant of matrix $\mathbf{F}^{[1]}$ has a unique monomial which implies that $\det(\mathbf{F}^{[1]}) \neq 0$, almost surely. Expanding the determinant of $\mathbf{F}^{[1]}$ along the interference signal columns corresponding to \mathbf{E}^1 , it can be noted that $\det(\mathbf{F}^{[1]})$ contains the polynomial $\mathcal{I}_P \det(\mathbf{X})$

with $\mathcal{I}_P = \mathcal{I}_A \mathcal{I}_B$ and

$$\mathcal{I}_A = \left(\prod_{i=1}^{|\bar{\mathbf{V}}|} \bar{\mathcal{I}}_i(i) \right) \times \left(\prod_{i=|\bar{\mathbf{V}}|+1}^{|\bar{\mathcal{I}}|} \bar{\mathcal{I}}_{i-|\bar{\mathbf{V}}|}(i) \right) \quad (2.70)$$

$$\mathcal{I}_B = \prod_{i=|\bar{\mathbf{V}}|+1}^n \bar{\mathcal{I}}_{i-|\bar{\mathbf{V}}|}(i) \quad (2.71)$$

wherein \mathcal{I}_A is the product of interference terms from even rows of $\mathbf{F}^{[1]}$, \mathcal{I}_B is the product of interference terms from odd rows of $\mathbf{F}^{[1]}$, $\mathcal{I}_P = \mathcal{I}_A \mathcal{I}_B$ represents the product of interference terms from the columns of $\mathbf{E}^{[1]}$ described above, and the matrix \mathbf{X} is given as

$$\mathbf{X} = \begin{bmatrix} \alpha_1 \bar{\mathbf{H}}_1^{[11]}(1) \bar{\mathbf{V}}(1, :) & \alpha_1 \bar{\mathbf{H}}_1^{[12]}(1) \bar{\mathbf{V}}(1, :) \\ \alpha_2 \bar{\mathbf{H}}_1^{[11]}(2) \bar{\mathbf{V}}(2, :) & \alpha_2 \bar{\mathbf{H}}_1^{[12]}(2) \bar{\mathbf{V}}(2, :) \\ \vdots & \vdots \\ \alpha_{|\bar{\mathbf{V}}|} \bar{\mathbf{H}}_1^{[11]}(|\bar{\mathbf{V}}|) \bar{\mathbf{V}}(|\bar{\mathbf{V}}|, :) & \alpha_{|\bar{\mathbf{V}}|} \bar{\mathbf{H}}_1^{[12]}(|\bar{\mathbf{V}}|) \bar{\mathbf{V}}(|\bar{\mathbf{V}}|, :) \\ \bar{\mathbf{H}}_1^{[11]}(|\bar{\mathcal{I}}|+1) \bar{\mathbf{V}}(|\bar{\mathcal{I}}|+1, :) & \bar{\mathbf{H}}_1^{[12]}(|\bar{\mathcal{I}}|+1) \bar{\mathbf{V}}(|\bar{\mathcal{I}}|+1, :) \\ \vdots & \vdots \\ \bar{\mathbf{H}}_1^{[11]}(n) \bar{\mathbf{V}}(n, :) & \bar{\mathbf{H}}_1^{[12]}(n) \bar{\mathbf{V}}(n, :) \end{bmatrix}_{2|\bar{\mathbf{V}}| \times 2|\bar{\mathbf{V}}|} \quad (2.72)$$

$$\text{and } \det(\mathbf{X}) = \left(\prod_{i=1}^{|\bar{\mathbf{V}}|} \alpha_i \right) \det(\bar{\mathbf{X}}) \quad (2.73)$$

$$\text{wherein } \bar{\mathbf{X}} = \begin{bmatrix} \bar{\mathbf{H}}_1^{[11]}(1) \bar{\mathbf{V}}(1, :) & \bar{\mathbf{H}}_1^{[12]}(1) \bar{\mathbf{V}}(1, :) \\ \bar{\mathbf{H}}_1^{[11]}(2) \bar{\mathbf{V}}(2, :) & \bar{\mathbf{H}}_1^{[12]}(2) \bar{\mathbf{V}}(2, :) \\ \vdots & \vdots \\ \bar{\mathbf{H}}_1^{[11]}(|\bar{\mathbf{V}}|) \bar{\mathbf{V}}(|\bar{\mathbf{V}}|, :) & \bar{\mathbf{H}}_1^{[12]}(|\bar{\mathbf{V}}|) \bar{\mathbf{V}}(|\bar{\mathbf{V}}|, :) \\ \bar{\mathbf{H}}_1^{[11]}(|\bar{\mathcal{I}}|+1) \bar{\mathbf{V}}(|\bar{\mathcal{I}}|+1, :) & \bar{\mathbf{H}}_1^{[12]}(|\bar{\mathcal{I}}|+1) \bar{\mathbf{V}}(|\bar{\mathcal{I}}|+1, :) \\ \vdots & \vdots \\ \bar{\mathbf{H}}_1^{[11]}(n) \bar{\mathbf{V}}(n, :) & \bar{\mathbf{H}}_1^{[12]}(n) \bar{\mathbf{V}}(n, :) \end{bmatrix}_{2|\bar{\mathbf{V}}| \times 2|\bar{\mathbf{V}}|} \quad (2.74)$$

Different choice for interference terms in \mathcal{I}_P ($\mathcal{I}_P \neq \mathcal{I}_A \mathcal{I}_B$), result in either a different matrix $\tilde{\mathbf{X}}$ (instead of \mathbf{X}) corresponding to rows from different timeslots, or another distinct product of α_i in the determinant expression of same \mathbf{X} , instead of that in (2.73). Choosing a different row for

each term $\bar{\mathcal{I}}_k(\kappa)$ than from one above, results in either a different matrix \mathbf{X} or a different product of α_i coefficients. Note that $\det(\mathbf{X})$ is a non-zero polynomial since rows correspond to different timeslots, and elements can be chosen such that one instance of the determinant polynomial is non-zero. Also, each element of matrix \mathbf{X} has direct channels which are not present in all elements of $\bar{\mathcal{I}}$. Elements of $\bar{\mathcal{I}}$ are distinct powers of the cross channels with non-zero entries. Thus, we have a unique non-zero polynomial $\mathcal{I}_A \mathcal{I}_B \det(\mathbf{X})$ in the determinant expression of $\mathbf{F}^{[1]}$ and so the determinant of $\mathbf{F}^{[1]}$ is non-zero, almost surely. Similarly, we can show that all matrices $\mathbf{F}^{[k]}, k \in \{2, \dots, K\}$ are full rank, corresponding to signal space at different receivers. Suppose the 2×2 direct channel between Transmitter 1 and Receiver 1 is full rank, matrix $\mathbf{F}^{[1]}$ can be similarly shown to be full rank, almost surely.

Thus the desired signal is linearly independent from the interference at each receiver and therefore, the total accessible DoF for Receiver j equals $M \frac{2|\bar{\mathcal{V}}|}{2n} = M \frac{2|\bar{\mathcal{V}}|}{2|\bar{\mathcal{V}}|+2|\bar{\mathcal{I}}|} \rightarrow \frac{M}{2}$ as $n \rightarrow \infty$, resulting in DoF of $\frac{M}{2}$ per user, as desired.

B. Linear independence proof for arbitrary M

For arbitrary M , signal space containing desired signal and interference is represented as:

$$\mathbf{F}^{[1]} = \begin{bmatrix} \mathbf{D}^{[1]} & \mathbf{E}^{[1]} \end{bmatrix}_{nM \times nM} \quad (2.75)$$

wherein the columns corresponding to the desired signals are represented using $\mathbf{D}^{[1]}$

$$\mathbf{D}^{[1]} = \begin{bmatrix} \mathbf{D}^{[1]}(1) \\ \mathbf{D}^{[1]}(2) \\ \vdots \\ \mathbf{D}^{[1]}(n) \end{bmatrix}_{nM \times M|\bar{\mathbf{V}}|} \quad (2.76)$$

$$\mathbf{D}^{[1]}(\kappa) = \mathbf{H}_{11}(\kappa) \otimes \bar{\mathbf{V}}(\kappa, :) = \begin{bmatrix} \bar{\mathbf{H}}_1^{[11]}(\kappa)\bar{\mathbf{V}}(\kappa, :) & \bar{\mathbf{H}}_1^{[12]}(\kappa)\bar{\mathbf{V}}(\kappa, :) & \cdots & \bar{\mathbf{H}}_1^{[1M]}(\kappa)\bar{\mathbf{V}}(\kappa, :) \\ \bar{\mathbf{H}}_2^{[11]}(\kappa)\bar{\mathbf{V}}(\kappa, :) & \bar{\mathbf{H}}_2^{[12]}(\kappa)\bar{\mathbf{V}}(\kappa, :) & \cdots & \bar{\mathbf{H}}_2^{[1M]}(\kappa)\bar{\mathbf{V}}(\kappa, :) \\ \vdots & \vdots & \ddots & \vdots \\ \bar{\mathbf{H}}_M^{[11]}(\kappa)\bar{\mathbf{V}}(\kappa, :) & \bar{\mathbf{H}}_M^{[12]}(\kappa)\bar{\mathbf{V}}(\kappa, :) & \cdots & \bar{\mathbf{H}}_M^{[1M]}(\kappa)\bar{\mathbf{V}}(\kappa, :) \end{bmatrix}_{M \times M|\bar{\mathbf{V}}|} \quad (2.77)$$

and the columns corresponding to the interference signals are represented using $\mathbf{E}^{[1]}$

$$\mathbf{E}^{[1]} = \begin{bmatrix} \bar{\mathbf{x}}(1,1) & \cdots & \bar{\mathbf{x}}(1,|\bar{\mathbf{I}}|) & 0 & \cdots & 0 & 0 & \cdots & 0 & 0 & \cdots & 0 \\ 0 & \cdots & 0 & \bar{\mathbf{x}}(1,1) & \cdots & \bar{\mathbf{x}}(1,|\bar{\mathbf{I}}|) & 0 & \cdots & 0 & 0 & \cdots & 0 \\ \vdots & \vdots & \vdots & \vdots & \vdots & \vdots & \vdots & \ddots & \vdots & \vdots & \vdots & \vdots \\ 0 & \cdots & 0 & 0 & \cdots & 0 & 0 & \cdots & 0 & \bar{\mathbf{x}}(1,1) & \cdots & \bar{\mathbf{x}}(1,|\bar{\mathbf{I}}|) \\ \bar{\mathbf{x}}(2,1) & \cdots & \bar{\mathbf{x}}(2,|\bar{\mathbf{I}}|) & 0 & \cdots & 0 & 0 & \cdots & 0 & 0 & \cdots & 0 \\ 0 & \cdots & 0 & \bar{\mathbf{x}}(2,1) & \cdots & \bar{\mathbf{x}}(2,|\bar{\mathbf{I}}|) & 0 & \cdots & 0 & 0 & \cdots & 0 \\ \vdots & \vdots & \vdots & \vdots & \vdots & \vdots & \vdots & \ddots & \vdots & \vdots & \vdots & \vdots \\ 0 & \cdots & 0 & 0 & \cdots & 0 & 0 & \cdots & 0 & \bar{\mathbf{x}}(2,1) & \cdots & \bar{\mathbf{x}}(2,|\bar{\mathbf{I}}|) \\ \vdots & \vdots & \vdots & \vdots & \vdots & \vdots & \vdots & \ddots & \vdots & \vdots & \vdots & \vdots \\ \bar{\mathbf{x}}(|\bar{\mathbf{V}}|,1) & \cdots & \bar{\mathbf{x}}(|\bar{\mathbf{V}}|,|\bar{\mathbf{I}}|) & 0 & \cdots & 0 & 0 & \cdots & 0 & 0 & \cdots & 0 \\ 0 & \cdots & 0 & \bar{\mathbf{x}}(|\bar{\mathbf{V}}|,1) & \cdots & \bar{\mathbf{x}}(|\bar{\mathbf{V}}|,|\bar{\mathbf{I}}|) & 0 & \cdots & 0 & 0 & \cdots & 0 \\ \vdots & \vdots & \vdots & \vdots & \vdots & \vdots & \vdots & \ddots & \vdots & \vdots & \vdots & \vdots \\ 0 & \cdots & 0 & 0 & \cdots & 0 & 0 & \cdots & 0 & \bar{\mathbf{x}}(|\bar{\mathbf{V}}|,1) & \cdots & \bar{\mathbf{x}}(|\bar{\mathbf{V}}|,|\bar{\mathbf{I}}|) \\ \vdots & \vdots & \vdots & \vdots & \vdots & \vdots & \vdots & \ddots & \vdots & \vdots & \vdots & \vdots \\ \bar{\mathbf{x}}(n,1) & \cdots & \bar{\mathbf{x}}(n,|\bar{\mathbf{I}}|) & 0 & \cdots & 0 & 0 & \cdots & 0 & 0 & \cdots & 0 \\ 0 & \cdots & 0 & \bar{\mathbf{x}}(n,1) & \cdots & \bar{\mathbf{x}}(n,|\bar{\mathbf{I}}|) & 0 & \cdots & 0 & 0 & \cdots & 0 \\ \vdots & \vdots & \vdots & \vdots & \vdots & \vdots & \vdots & \ddots & \vdots & \vdots & \vdots & \vdots \\ 0 & \cdots & 0 & 0 & \cdots & 0 & 0 & \cdots & 0 & \bar{\mathbf{x}}(n,1) & \cdots & \bar{\mathbf{x}}(n,|\bar{\mathbf{I}}|) \end{bmatrix}_{nM \times M|\bar{\mathbf{I}}|} \quad (2.78)$$

where $\bar{\mathbf{V}}(\kappa, :)$ denotes κ -th row of $\bar{\mathbf{V}}$, and $\bar{\mathcal{I}}(k, l)$ denotes the element in the k -th row and l -th column of $\bar{\mathcal{I}}$. When desired channels are of rank $D_0 > \frac{M}{2}$, above matrix can be written as

$$\mathbf{D}^{[1]}(\kappa) = \mathbf{H}_{11}(\kappa) \otimes \bar{\mathbf{V}}(\kappa, :) = \begin{bmatrix} \mathbf{a}_1 & \mathbf{b}_1 & \mathbf{c}_1 & \cdots \\ \vdots & \vdots & \vdots & \vdots \\ \mathbf{a}_{\frac{M}{2}} & \mathbf{b}_{\frac{M}{2}} & \mathbf{c}_{\frac{M}{2}} & \cdots \\ \sum_{i=1}^{\frac{M}{2}} \alpha_i a_i & \sum_{i=1}^{\frac{M}{2}} \alpha_i b_i & \sum_{i=1}^{\frac{M}{2}} \alpha_i c_i & \cdots \\ \vdots & \vdots & \vdots & \cdots \\ \sum_{i=1}^{\frac{M}{2}} \beta_i a_i & \sum_{i=1}^{\frac{M}{2}} \beta_i b_i & \sum_{i=1}^{\frac{M}{2}} \beta_i c_i & \cdots \end{bmatrix}_{M \times M|\bar{\mathbf{V}}|} \quad (2.79)$$

Expanding the determinant of $\mathbf{F}^{[1]}$ along the columns carrying interference, note that the determinant contains the polynomial $\mathcal{I}_P \det(\mathbf{X})$ with $\mathcal{I}_P = \mathcal{I}_A \mathcal{I}_B$ and

$$\mathcal{I}_A = \left(\prod_{i=1}^{|\bar{\mathbf{V}}|} \bar{\mathcal{I}}_i^{\frac{M}{2}}(i) \right) \times \left(\prod_{i=|\bar{\mathbf{V}}|+1}^{|\bar{\mathcal{I}}|} \bar{\mathcal{I}}_{i-|\bar{\mathbf{V}}|}^{\frac{M}{2}}(i) \right) \quad (2.80)$$

$$\mathcal{I}_B = \prod_{i=|\bar{\mathbf{V}}|+1}^n \bar{\mathcal{I}}_{i-|\bar{\mathbf{V}}|}^{\frac{M}{2}}(i) \quad (2.81)$$

wherein \mathcal{I}_A is the product of interference terms from the middle $\frac{M}{2}$ rows of each M -row matrix corresponding to same channel use, in $\mathbf{F}^{[1]}$, \mathcal{I}_B is the product of interference terms from the top $\lceil \frac{M}{4} \rceil$ and the bottom $\lfloor \frac{M}{4} \rfloor$ rows of each M -row matrix corresponding to same channel use, in $\mathbf{F}^{[1]}$, and the matrix \mathbf{X} is given as:

$$\mathbf{X} = \begin{bmatrix} \tilde{\mathbf{X}}(1) \\ \tilde{\mathbf{X}}(2) \\ \vdots \\ \tilde{\mathbf{X}}(|\tilde{\mathcal{I}}|) \\ \mathbf{X}'(|\tilde{\mathcal{I}}| + 1) \\ \vdots \\ \mathbf{X}'(n) \end{bmatrix}_{M|\tilde{\mathcal{V}}| \times M|\tilde{\mathcal{V}}|} \quad (2.82)$$

$$\tilde{\mathbf{X}}(k) = \begin{bmatrix} \bar{\mathbf{H}}_1^{[11]}(k)\bar{\mathbf{V}}(k,:) & \bar{\mathbf{H}}_1^{[12]}(k)\bar{\mathbf{V}}(k,:) & \cdots & \bar{\mathbf{H}}_1^{[1M]}(k)\bar{\mathbf{V}}(k,:) \\ \vdots & \vdots & \ddots & \vdots \\ \bar{\mathbf{H}}_{\lceil \frac{M}{4} \rceil}^{[11]}(k)\bar{\mathbf{V}}(k,:) & \bar{\mathbf{H}}_{\lceil \frac{M}{4} \rceil}^{[12]}(k)\bar{\mathbf{V}}(k,:) & \cdots & \bar{\mathbf{H}}_{\lceil \frac{M}{4} \rceil}^{[1M]}(k)\bar{\mathbf{V}}(k,:) \\ \bar{\mathbf{H}}_{\lceil \frac{3M}{4} \rceil}^{[11]}(k)\bar{\mathbf{V}}(k,:) & \bar{\mathbf{H}}_{\lceil \frac{3M}{4} \rceil}^{[12]}(k)\bar{\mathbf{V}}(k,:) & \cdots & \bar{\mathbf{H}}_{\lceil \frac{3M}{4} \rceil}^{[1M]}(k)\bar{\mathbf{V}}(k,:) \\ \vdots & \vdots & \ddots & \vdots \\ \bar{\mathbf{H}}_M^{[11]}(k)\bar{\mathbf{V}}(k,:) & \bar{\mathbf{H}}_M^{[12]}(k)\bar{\mathbf{V}}(k,:) & \cdots & \bar{\mathbf{H}}_M^{[1M]}(k)\bar{\mathbf{V}}(k,:) \end{bmatrix} \quad (2.83)$$

$$\mathbf{X}'(k) = \begin{bmatrix} \bar{\mathbf{H}}_{\lceil \frac{M}{4} \rceil + 1}^{[11]}(k)\bar{\mathbf{V}}(k,:) & \bar{\mathbf{H}}_{\lceil \frac{M}{4} \rceil + 1}^{[12]}(k)\bar{\mathbf{V}}(k,:) & \cdots & \bar{\mathbf{H}}_{\lceil \frac{M}{4} \rceil + 1}^{[1M]}(k)\bar{\mathbf{V}}(k,:) \\ \vdots & \vdots & \ddots & \vdots \\ \bar{\mathbf{H}}_{\lceil \frac{3M}{4} \rceil - 1}^{[11]}(k)\bar{\mathbf{V}}(k,:) & \bar{\mathbf{H}}_{\lceil \frac{3M}{4} \rceil - 1}^{[12]}(k)\bar{\mathbf{V}}(k,:) & \cdots & \bar{\mathbf{H}}_{\lceil \frac{3M}{4} \rceil - 1}^{[1M]}(k)\bar{\mathbf{V}}(k,:) \end{bmatrix} \quad (2.84)$$

When determinant of \mathbf{X} is evaluated, we get terms of the form $a_k(\sum_{i=1}^{D_0} \beta_i b_i)$, $k \in \{1, \dots, D_0\}$ when $D_0 > \frac{M}{2}$ corresponding to channel use κ , by considering (2.79). For obtaining same product of interference terms in \mathcal{I}_A and \mathcal{I}_B by choosing different rows, different linear combinations of $a_i, b_i, i \in \{1, \dots, D_0\}$ are involved. Choosing a different row for each term $\bar{\mathcal{I}}_k(\kappa)$ in \mathcal{I}_P than from one above, results in either a different matrix \mathbf{X} or a different linear combination of $a_i, b_i, i \in \{1, \dots, D_0\}$. Also, each element of matrix \mathbf{X} has direct channels which are not present in all elements of $\bar{\mathcal{I}}$. Thus we have a unique non-zero polynomial $\mathcal{I}_A \mathcal{I}_B \det(\mathbf{X})$ in the determinant of $\mathbf{F}^{[1]}$, since any other choices for interference terms cannot result in the same polynomial, and so, $\det(\mathbf{F}^{[1]}) \neq 0$, almost surely. Similarly, we can show that all matrices $\mathbf{F}^{[k]}, k \in \{2, \dots, K\}$ are full rank, corresponding to signal space at different receivers.

Hence the matrix $\mathbf{F}^{[k]}$ is full rank and we have proved the linear independence of desired and interfering signals, for all M . This implies that for the region $(K - 1)D > M$, achievable DoF per user are $\min(D_0, \frac{M}{2})$. ■

2.6.3 Theorem 2.3: Proof of Outer Bound

We first prove that the DoF outer bound per user for region $(K - 1)D \leq M$ is given by $M - \frac{(K-1)D}{2}$, and then prove that $\frac{M}{2}$ is the DoF outer bound per user for regions $(K - 2)D \leq M < (K - 1)D$ and $(K - 2)D > M$.

K -user channel with $(K - 1)D \leq M$:

Change of Basis:

Step 1: For Receiver k , we design a $M \times M$ square matrix \mathbf{R}_k . First, we determine $(K - 1)D$ rows at Receiver k . The linear transformation is designed such that first D antennas of Receiver k hears only Transmitter $k + 1$, next D antennas of Receiver k hears only Transmitter $k + 2$, and so on till D antennas of Receiver k hears only Transmitter $k + K - 1$. This operation is guaranteed since $\text{rank}(\mathbf{H}_{k(k+i)}) = D, i \neq 0$, and vectors can be chosen from the corresponding common nullspaces. For Receiver k , these are denoted as $S_{ka_1}, \dots, S_{ka_{K-1}}$. Remaining $M - (K - 1)D$ rows are chosen so that they do not hear all $K - 1$ interferers, denoted as S_{kc} , which is also possible since the common nullspace of $K - 1$ cross channels has $M - (K - 1)D$ dimensions.

Step 2: Within the M -dimensional signal space at Transmitter k , there is $M - (K - 1)D$ dimensional subspace orthogonal to $(K - 1)D$ receiver antennas $(k - i)a_i, \forall i = \{1, \dots, K - 1\}$. These $K - 1$ subspaces have $M - (K - 1)D$ dimensional intersection as seen by Transmitter k . We will choose $M - (K - 1)D$ columns of a $M \times M$ matrix \mathbf{T}_k at Transmitter k , from this intersection. These will not be seen at any of unintended receivers, and are denoted as X_{kc} at Transmitter k .

$ X_{1a_1} = D$	X_{1a_1}	○		○ $S_{1a_1}(X_{2a_1})$	$ S_{1a_1} = D$		
$ X_{1a_2} = D$	X_{1a_2}	○		○ $S_{1a_2}(X_{3a_2})$	$ S_{1a_2} = D$		
○	○	○		○ ○	○		
$ X_{1a_{K-1}} = D$	$X_{1a_{K-1}}$	○		○ $S_{1a_{K-1}}(X_{Ka_{K-1}})$	$ S_{1a_{K-1}} = D$		
$ X_{1c} = M - (K - 1)D \geq 0$	X_{1c}	○		○ $S_{1c}()$	$ S_{1c} = M - (K - 1)D \geq 0$		
$ X_{2a_1} = D$	X_{2a_1}	○		○ $S_{2a_1}(X_{3a_1})$	$ S_{2a_1} = D$		
$ X_{2a_2} = D$	X_{2a_2}	○		○ $S_{2a_2}(X_{4a_2})$	$ S_{2a_2} = D$		
○	○	○		○ ○	○		
$ X_{2a_{K-1}} = D$	$X_{2a_{K-1}}$	○		○ $S_{2a_{K-1}}(X_{1a_{K-1}})$	$ S_{2a_{K-1}} = D$		
$ X_{2c} = M - (K - 1)D \geq 0$	X_{2c}	○		○ $S_{2c}()$	$ S_{2c} = M - (K - 1)D \geq 0$		
$ X_{3a_1} = D$	X_{3a_1}	○		○ $S_{3a_1}(X_{4a_1})$	$ S_{3a_1} = D$		
$ X_{3a_2} = D$	X_{3a_2}	○		○ $S_{3a_2}(X_{5a_2})$	$ S_{3a_2} = D$		
○	○	○		○ ○	○		
$ X_{3a_{K-1}} = D$	$X_{3a_{K-1}}$	○		○ $S_{3a_{K-1}}(X_{2a_{K-1}})$	$ S_{3a_{K-1}} = D$		
$ X_{3c} = M - (K - 1)D \geq 0$	X_{3c}	○		○ $S_{3c}()$	$ S_{3c} = M - (K - 1)D \geq 0$		
$ X_{Ka_1} = D$	X_{Ka_1}	○		○ $S_{Ka_1}(X_{1a_1})$	$ S_{Ka_1} = D$		
$ X_{Ka_2} = D$	X_{Ka_2}	○		○ $S_{Ka_2}(X_{2a_2})$	$ S_{Ka_2} = D$		
○	○	○		○ ○	○		
$ X_{Ka_{K-1}} = D$	$X_{Ka_{K-1}}$	○		○ $S_{Ka_{K-1}}(X_{(K-1)a_{K-1}})$	$ S_{Ka_{K-1}} = D$		
$ X_{Kc} = M - (K - 1)D \geq 0$	X_{Kc}	○		○ $S_{Kc}()$	$ S_{Kc} = M - (K - 1)D \geq 0$		

Figure 2.14: Outer bound: K -user rank deficient interference channel, $(K - 1)D < M$

Step 3: Then, we choose other columns of \mathbf{T}_k such that D antennas of Transmitter k are heard only by receiver antennas $(k - i)a_i, \forall i = \{1, \dots, K - 1\}$. This operation is guaranteed since $\text{rank}(\mathbf{H}_{k(k+i)}) = D, i \neq 0$, and we can choose vectors from the corresponding common nullspaces. For Transmitter k , these are denoted as $X_{ka_1}, \dots, X_{ka_{K-1}}$. Note that invertibility of these linear transformations is guaranteed. Resulting network connectivity after the change of basis operations is shown in Figure 2.14.

Outer bound:

Genie information given to Receiver 1 should include $(K - 1)(M - D)$ dimensions -

$X_{2a_2}^n, \dots, X_{2a_{K-1}}^n, X_{2c}^n, X_{3a_1}^n, X_{3a_3}^n, \dots, X_{3a_{K-1}}^n, X_{3c}^n, X_{Ka_1}^n, \dots, X_{Ka_{K-2}}^n, X_{Kc}^n$ which are not heard by

Receiver 1. Receiver 1 has M equations with $(K - 1)D$ unknowns. Since $(K - 1)D \leq M$, by processing signal using $(K - 1)D$ antennas, we can resolve $(K - 1)D$ unknowns.

Hence a genie provides $\mathcal{G}_1 = \{X_{2a_2}^n, \dots, X_{2a_{K-1}}^n, X_{2c}^n, X_{3a_1}^n, X_{3a_3}^n, \dots, X_{3a_{K-1}}^n, X_{3c}^n, X_{Ka_1}^n, \dots, X_{Ka_{K-2}}^n, X_{Kc}^n\}$ to Receiver 1. Receiver 1 processes signal only from the first $(K - 1)D$ antennas. Then the total number of dimensions available to Receiver 1 (including those provided by the genie) is equal to:

$$(K - 1)D + |\mathcal{G}_1| = (K - 1)D + (K - 1)(M - D) = (K - 1)M \quad (2.85)$$

With these $(K - 1)M$ dimensions, Receiver 1 will be able to resolve all $K - 1$ interfering signals and can decode all K messages. For example, $\mathcal{G}_1 = \{X_{2a_2}^n, X_{2a_3}^n, X_{2c}^n, X_{3a_1}^n, X_{3a_3}^n, X_{3c}^n, X_{4a_1}^n, X_{4a_2}^n, X_{4c}^n\}$ for $K = 4$. Therefore, we have:

$$nR_\Sigma \leq Mn \log \rho + h(\mathcal{G}_1 | \bar{Y}_1^n) + n o(\log \rho) + o(n) \quad (2.86)$$

$$\begin{aligned} &\leq Mn \log \rho + h(X_{Ka_1}^n | \bar{Y}_1^n) + \dots + h(X_{Ka_{K-2}}^n | \bar{Y}_1^n) + h(X_{Kc}^n | \bar{Y}_1^n) + \\ &\quad h(X_{2a_2}^n, \dots, X_{2a_{K-1}}^n, X_{2c}^n | \bar{Y}_1^n) + h(X_{3a_1}^n, X_{3a_3}^n, \dots, X_{3a_{K-1}}^n, X_{3c}^n | \bar{Y}_1^n) + \dots + \\ &\quad h(X_{(K-1)a_1}^n, \dots, X_{(K-1)a_{K-3}}^n, X_{(K-1)a_{K-1}}^n, X_{(K-1)c}^n | \bar{Y}_1^n) + n o(\log \rho) + o(n) \end{aligned} \quad (2.87)$$

$$\begin{aligned} &\leq Mn \log \rho + h(X_{Ka_1}^n) + \dots + h(X_{Ka_{K-2}}^n) + h(X_{Kc}^n) + \\ &\quad h(X_{2a_2}^n, \dots, X_{2a_{K-1}}^n, X_{2c}^n | X_{2a_1}^n) + h(X_{3a_1}^n, X_{3a_3}^n, \dots, X_{3a_{K-1}}^n, X_{3c}^n | X_{3a_2}^n) + \dots + \\ &\quad h(X_{(K-1)a_1}^n, \dots, X_{(K-1)a_{K-3}}^n, X_{(K-1)a_{K-1}}^n, X_{(K-1)c}^n | X_{(K-1)a_{K-2}}^n) + n o(\log \rho) + o(n) \end{aligned} \quad (2.88)$$

$$\begin{aligned} &= Mn \log \rho + h(X_{Ka_1}^n) + \dots + h(X_{Ka_{K-2}}^n) + h(X_{Kc}^n) + nR_2 - h(X_{2a_1}^n) + \\ &\quad nR_3 - h(X_{3a_2}^n) + \dots + nR_{K-1} - h(X_{(K-1)a_{K-2}}^n) + n o(\log \rho) + o(n) \end{aligned} \quad (2.89)$$

$$\begin{aligned} &\leq Mn \log \rho + h(X_{Ka_1}^n) + \dots + h(X_{Ka_{K-2}}^n) + (M - (K - 1)D)n \log \rho + nR_2 - h(X_{2a_1}^n) + \\ &\quad nR_3 - h(X_{3a_2}^n) + \dots + nR_{K-1} - h(X_{(K-1)a_{K-2}}^n) + n o(\log \rho) + o(n) \end{aligned} \quad (2.90)$$

where (2.86) follows from Fano's inequality and Lemma 1. (2.87) follows from applying chain rule and dropping some condition terms. (2.88) follows from the fact that dropping condition terms cannot decrease the differential entropy. Thus, we only keep $S_{1a_1}^n, S_{1a_2}^n, \dots, S_{1a_{K-1}}^n$ as the condition terms which are $X_{2a_1}^n, X_{3a_2}^n, \dots, X_{Ka_{K-1}}^n$ respectively. (2.89) is obtained because from the observations of $(X_{ka_1}^n, X_{ka_2}^n, \dots, X_{ka_{K-1}}^n, X_{kc}^n)$ we can decode $W_k, \forall k \in \{1, \dots, K\}$ subject to the noise distortion, (2.90) follows since entropy of X_{Kc}^n is constrained by $M - (K - 1)D$ antennas.

By advancing user indices considering all receivers, we have:

$$KnR \leq (2M - (K - 1)D)n \log \rho + (K - 2)nR + n o(\log \rho) + o(n). \quad (2.91)$$

which implies that

$$d \leq M - \frac{(K - 1)D}{2} \quad (2.92)$$

Thus, DoF per user is outer bounded as $d \leq M - \frac{(K-1)D}{2}$ when $D \leq \frac{M}{K-1}$.

K -user channel with $(K - 2)D \leq M < (K - 1)D$:

Change of Basis:

Step 1: For Receiver k , we design a $M \times M$ square matrix \mathbf{R}_k . First, we determine $(K - 2)D$ rows at Receiver k . The linear transformation is designed such that first D antennas of Receiver k hears only Transmitter $k + 1$, next D antennas of Receiver k hears only Transmitter $k + 2$, and so on till D antennas of Receiver k hears only Transmitter $k + K - 2$. This operation is guaranteed since $\text{rank}(\mathbf{H}_{k(k+i)}) = D, i \neq 0$, and vectors can be chosen from corresponding common nullspaces. For Receiver k , these are denoted as $S_{ka_1}, \dots, S_{ka_{K-2}}$. Remaining $M - (K - 2)D$ rows are chosen

so that they hear Transmitter $k + K - 1$ only, denoted as S_{kc} , which is possible since the common nullspace of $K - 2$ cross channels has $M - (K - 2)D$ dimensions.

Step 2: Within the M -dimensional signal space at Transmitter k , there is $M - (K - 2)D$ dimensional subspace orthogonal to $(K - 2)D$ receiver antennas $(k - i)a_i, \forall i = \{1, \dots, K - 2\}$. These $K - 2$ subspaces have $M - (K - 2)D$ dimensional intersection as seen by Transmitter k . We will choose $M - (K - 2)D$ columns of a $M \times M$ matrix \mathbf{T}_k at Transmitter k from this intersection. These are denoted as X_{kc_1} at Transmitter k .

$ X_{1a_1} = D$	X_{1a_1}	\circ	\circ	$S_{1a_1}(X_{2a_1})$	$ S_{1a_1} = D$
		\circ	\circ	\circ	
$ X_{1a_{K-2}} = D$	$X_{1a_{K-2}}$	\circ	\circ	\circ	
$ X_{1c_1} = M - (K - 2)D$	X_{1c_1}	\circ	\circ	$S_{1a_{K-2}}(X_{(K-1)a_{K-2}})$	$ S_{1a_{K-2}} = D$
$ X_{1c_2} = (K - 1)D - M \geq 0$	X_{1c_2}			$S_{1c}(X_{Kc_1}, X_{Kc_2})$	$ S_{1c} = M - (K - 2)D$
$ X_{2a_1} = D$	X_{2a_1}	\circ	\circ	$S_{2a_1}(X_{3a_1})$	$ S_{2a_1} = D$
		\circ	\circ	\circ	
$ X_{2a_{K-2}} = D$	$X_{2a_{K-2}}$	\circ	\circ	\circ	
$ X_{2c_1} = M - (K - 2)D$	X_{2c_1}	\circ	\circ	$S_{2a_{K-2}}(X_{Ka_{K-2}})$	$ S_{2a_{K-2}} = D$
$ X_{2c_2} = (K - 1)D - M \geq 0$	X_{2c_2}			$S_{2c}(X_{1c_1}, X_{1c_2})$	$ S_{2c} = M - (K - 2)D$
$ X_{3a_1} = D$	X_{3a_1}	\circ	\circ	$S_{3a_1}(X_{4a_1})$	$ S_{3a_1} = D$
		\circ	\circ	\circ	
$ X_{3a_{K-2}} = D$	$X_{3a_{K-2}}$	\circ	\circ	\circ	
$ X_{3c_1} = M - (K - 2)D$	X_{3c_1}	\circ	\circ	$S_{3a_{K-2}}(X_{1a_{K-2}})$	$ S_{3a_{K-2}} = D$
$ X_{3c_2} = (K - 1)D - M \geq 0$	X_{3c_2}			$S_{3c}(X_{2c_1}, X_{2c_2})$	$ S_{3c} = M - (K - 2)D$
$ X_{Ka_1} = D$	X_{Ka_1}	\circ	\circ	$S_{Ka_1}(X_{1a_1})$	$ S_{Ka_1} = D$
		\circ	\circ	\circ	
$ X_{Ka_{K-2}} = D$	$X_{Ka_{K-2}}$	\circ	\circ	\circ	
$ X_{Kc_1} = M - (K - 2)D$	X_{Kc_1}	\circ	\circ	$S_{Ka_{K-2}}(X_{(K-2)a_{K-2}})$	$ S_{Ka_{K-2}} = D$
$ X_{Kc_2} = (K - 1)D - M \geq 0$	X_{Kc_2}			$S_{Kc}(X_{(K-1)c_1}, X_{(K-1)c_2})$	$ S_{Kc} = M - (K - 2)D$

Figure 2.15: Outer bound: K -user rank deficient interference channel, $(K - 2)D \leq M < (K - 1)D$

Step 3: Other columns of \mathbf{T}_k are chosen such that D antennas of Transmitter k are heard only by receiver antennas $(k - i)a_i, \forall i = \{1, \dots, K - 2\}$. This operation is guaranteed since $\text{rank}(\mathbf{H}_{k(k+i)})$

$= D, i \neq 0$, and we can choose vectors from corresponding common nullspaces. For Transmitter k , these are denoted as $X_{ka_1}, \dots, X_{ka_{K-2}}$. Note that invertibility of these linear transformations is guaranteed. Resulting network connectivity after the change of basis operations is shown in Figure 2.15.

In this setting, note that X_{kc_2} at all transmitters k do not represent actual antennas, but are just linear combinations of $X_{ka_1}, \dots, X_{ka_{K-2}}$. While $X_{ka_1}, \dots, X_{ka_{K-2}}$ dimensions are each seen by one of the $K - 2$ unintended receivers, X_{kc_1}, X_{kc_2} with D dimensions, will be seen only by $(K - 1)$ th unintended receiver.

Outer bound:

Genie information given to Receiver 1 should include signals not seen by Receiver 1, i.e., $(K - 1)(M - D)$ dimensions. This is because Receiver 1 sees only D dimensions each from $K - 1$ unintended transmitters, nullspace of each has $M - D$ dimensions. Additionally, $(K - 1)D - M$ dimensions corresponding to Kc_2 is also provided as part of Genie information to Receiver 1. Then the total number of dimensions available to Receiver 1 (including those provided by the genie) is:

$$M + |\mathcal{G}_1| = M + ((K - 1)(M - D)) + ((K - 1)D - M) = (K - 1)M \quad (2.93)$$

With these $(K - 1)M$ dimensions, Receiver 1 will be able to resolve all $K - 1$ interfering signals and can decode all K messages. Therefore, we have:

$$nR \leq I(Y_1, G; W_1) + n o(\log \rho) + o(n) \quad (2.94)$$

$$\leq M - h(Y_1|W_1, X_{Kc_2}) + n o(\log \rho) + o(n) \quad (2.95)$$

$$\leq M - h(X_{2a_1}, \dots, X_{(K-1)a_{K-2}}, X_{Kc_1}|X_{Kc_2}) + n o(\log \rho) + o(n) \quad (2.96)$$

$$\leq M - h(X_{2a_1}) - \dots - h(X_{(K-1)a_{K-2}}) - h(X_{Kc_1}|X_{Kc_2}) + n o(\log \rho) + o(n) \quad (2.97)$$

where (2.94) follows from Fano's inequality, (2.95) follows by expressing mutual information as entropies, (2.96) and (2.97) follows from the fact that dropping condition terms cannot decrease the differential entropy. Advancing user indices, we have:

$$nR \leq M - h(X_{a_1}) - \dots - h(X_{a_{K-2}}) - h(X_{c_1}) + n o(\log \rho) + o(n) \quad (2.98)$$

$$\leq M - nR + n o(\log \rho) + o(n) \quad (2.99)$$

$$d \leq \frac{M}{2} \quad (2.100)$$

Thus, DoF per user is outer bounded as $d \leq \frac{M}{2}$ when $(K-2)D \leq M < (K-1)D$.

K -user channel with $(K-2)D > M$:

Here, DoF per user are outer bounded by $\frac{M}{2}$ since $\frac{M}{2}$ is the outer bound per user for similar channel with only $K-1$ users. This is because adding one user to the $K-1$ user channel does not violate the converse argument. This is a recursive proof, in the sense that 4-user channel uses the known outer bound of $\frac{M}{2}$ for 3-user channel for the region $2D > M$. Similarly, 5-user channel uses the known outer bound of $\frac{M}{2}$ for 4-user channel for the region $3D > M$ and so on.

For example, let us consider the 4-user rank deficient channel in which sum of 3 cross channel ranks $3D > \frac{3M}{2}$. Within this channel, 3-user interference channel corresponding to first 3 users have sum of cross channel ranks $2D > M$, a region for which outer bound per user is known to be $\frac{M}{2}$. Adding the fourth user to this 3-user network does not violate the converse argument. Hence $\frac{M}{2}$ is an outer bound for the 4-user rank deficient channel. Similar argument can be extended to K user channels to show that $\frac{M}{2}$ is the DoF outer bound per user.

$$\frac{\text{DoF}}{K} \leq \min \left(D_0, M - \frac{\min(M, (K-1)D)}{2} \right) \quad (2.101)$$

Combining DoF outer bound results of all 3 regions along with min-cut bound of D_0 (direct channel rank), we get above outer bound on DoF per user for K -user rank deficient interference channel, as stated in Theorem 2.3. ■

2.7 Summary

Spatial dependencies often arise in MIMO interference networks, that impact their signaling dimensions. In this work, we studied spatial dependencies that are manifested as rank deficiencies of the MIMO channel matrices. 2-user and 3-user interference channels were studied involving non-asymptotic schemes for both constant and time-varying channels. While 2-user channel could only involve zero forcing, 3-user channel involves both zero-forcing and interference alignment. For 3-user channel with rank deficiencies, although there is more opportunity for zero-forcing and less opportunity for interference alignment, the increased opportunity for zero-forcing more than compensates for the lost opportunity in interference alignment.

More challenges are involved for the K -user interference channels with rank deficiencies. Both asymptotic interference alignment (CJ) and ergodic alignment schemes were studied in the context of K -user rank deficient interference channels with time-varying channel coefficients ($K > 3$). For K -user interference channel with individual channels of size $M \times M$ being rank deficient, optimal DoF per user was characterized as $\min\left(D_0, M - \frac{\min(M, (K-1)D)}{2}\right)$ where D_0 is the rank of direct channels, and $(K-1)D$ is the sum of ranks of cross channels at each receiver. When using CJ scheme, one of the remarkable aspects is that rank deficiencies in cross channels lead to columns of the precoding matrix being linearly dependent, however, by discarding those linearly dependent columns, DoF per user can be made arbitrarily close to $\frac{1}{2}$. We expect that the insights presented in this work would serve as stepping stones to translating DoF result to K -user rank deficient interference channels with constant channel coefficients. It could be noted that the achievable scheme involves joint processing of signals (one-sided decomposition) at the receivers,

for both ergodic and asymptotic interference alignment schemes. This is due to presence of spatial dependencies involving certain direct channels and cross channels in the fully decomposed network, because of rank deficient direct channels in the original network. While joint processing is sufficient to achieve optimal DoF using either ergodic or CJ scheme, whether it is also necessary is an intriguing open problem. Problem remains intriguing even if we consider single user ($K = 1$) MIMO channel with rank deficient channel matrix of size $M \times M$ with rank D .

Chapter 3

Two-hop Rank-deficient Interference Channels

3.1 Motivations

In this section, we explore a generalization of the $2 \times 2 \times 2$ interference network to the multiple-input-multiple-output (MIMO) setting with different channel ranks in the two hops. The goal is to shed light on the information theoretic implications of the dimensionality constraints of the sub-networks comprising a multihop multiflow network. Parameterizing the problem in terms of the ranks of each of the constituent channels, allows us to go beyond the basic min-cut arguments to identify an intriguing “*rank matching*” property, somewhat reminiscent of “*impedance matching*” in circuit theory. It is well known that the maximum power transfer in a circuit is achieved not for the maximum or minimum load impedance but for the load impedance that matches the source impedance. Similarly, the maximum DoF in the elementary $2 \times 2 \times 2$ MIMO interference network is achieved not for the maximum or minimum ranks of the destination hop, but when the ranks of

the destination hop match the ranks of the source hop. In fact, for mismatched settings of interest, the loss in DoF turns out to be precisely equal to the rank-mismatch between the two hops.

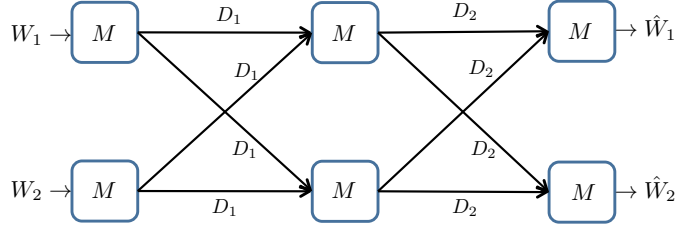

Figure 3.1: $2 \times 2 \times 2$ MIMO interference channel with M antennas at each node where all channels in the first hop have rank D_1 and all channels in the second hop have rank D_2 .

As an example, consider the $2 \times 2 \times 2$ MIMO interference channel illustrated in Fig. 3.1 where all nodes are equipped with M antennas, all channels in the first hop have rank D_1 , and all channels in the second hop have rank D_2 . Aside from the rank-constraints, the channels can take arbitrary values. The min-cut max-flow bound for this network simply states that the sum-DoF, $d_\Sigma \leq \min(4D_1, 4D_2, 2M)$. However, as we show in this work, the rank-constraints enforce the following rank-mismatch bound on the sum-DoF.

$$d_\Sigma \leq 2M - \Delta D \tag{3.1}$$

where $\Delta D = |D_1 - D_2|$ is the rank-mismatch term. Combined with the min-cut max-flow bounds, this produces the tightest possible bound for the given rank-constraints,

$$d_\Sigma \leq \min(4D_1, 4D_2, 2M - \Delta D) \tag{3.2}$$

This is the tightest bound possible in the sense that 1) it holds for *all* channels that satisfy the given rank-constraints, and 2) there exist channels that satisfy the given rank-constraints for which the bound is tight. In fact, the bound is tight for *almost all* channels that satisfy the rank-constraints. Remarkably, except for severely rank-deficient scenarios when the min-cut max-flow bounds are active, for moderately rank-deficient settings that are of main interest, it is the rank-mismatch

bound that is active. Also note that the best possible outcome, $d_\Sigma = 2M$, sometimes referred to as “everyone gets the entire cake” [22, 1, 48], is possible only if $\Delta D = 0$, i.e., ranks in the two hops are matched.

The rank matching phenomenon persists even in further generalized settings with arbitrary antenna configurations and/or redundant dimensions, i.e., when certain signal dimensions at a node may be inaccessible to/from any other node.

3.2 System Model

The $2 \times 2 \times 2$ MIMO interference channel is comprised of 3 layers and there are two nodes in each layer. Layer 1 contains the two source nodes $\mathcal{S}_1, \mathcal{S}_2$, layer 2 contains the two relay nodes $\mathcal{R}_1, \mathcal{R}_2$, and layer 3 contains the two destination nodes, $\mathcal{D}_1, \mathcal{D}_2$. All nodes are equipped with M antennas. At time index $t \in \mathbb{N}$, the various inputs and outputs are related as follows.

$$\mathbf{Y}_j^{l+1}(t) = \sum_{i=1}^2 \mathbf{H}_{ji}^l(t) \mathbf{X}_i^l(t) + \mathbf{Z}_j^{l+1}(t), \quad j \in \{1, 2\}, l \in \{1, 2\} \quad (3.3)$$

where $\mathbf{Y}_j^{l+1}(t)$ is the $M \times 1$ received signal vector observed at node j in layer $l + 1$, $\mathbf{X}_i^l(t)$ is the $M \times 1$ transmitted signal vector sent by node i in layer l and $\mathbf{Z}_j^{l+1}(t)$ is the $M \times 1$ vector of independent and identically distributed (i.i.d.) zero mean unit variance circularly symmetric complex Gaussian noise terms, respectively. $\mathbf{H}_{ji}^l(t)$ is the $M \times M$ channel matrix from node i in layer l to node j in layer $l + 1$. In other words, $\mathbf{H}_{ji}^l(t)$ is the channel matrix between node i and node j over the l -th hop. All symbols are complex and noise processes are i.i.d over time. \mathcal{S}_i has an independent message W_i for $\mathcal{D}_i, i \in \{1, 2\}$. Each transmitting node is subject to average power constraint P . The encoding functions at the relays are assumed to be known everywhere. The time index, t , will occasionally be suppressed for concise notation, when no ambiguity would

be caused. The rank-constraints are stated as follows, $\forall t \in \mathbb{N}$.

$$\text{rank}(\mathbf{H}_{ji}^1(t)) = D_1 \qquad \text{rank}(\mathbf{H}_{ji}^2(t)) = D_2 \qquad (3.4)$$

The channel coefficients can take arbitrary values and are also allowed to vary in time as long as the rank-constraints are satisfied and the non-zero singular values of each channel matrix are bounded away from zero and infinity. Unless stated explicitly, we do not require that the channels be in general position. Perfect channel knowledge is assumed everywhere. Finally, the definitions of codebooks, achievable rates, capacity, and degrees of freedom are all used in the standard sense.

3.3 Results

In this section we present our two main results — the rank mismatch outer bound, and a proof that (along with the min-cut max-flow bound) it is tight, in this symmetric setting.

3.3.1 Rank-Mismatch Outer Bound

THEOREM 3.1. *For the rank-constrained $2 \times 2 \times 2$ MIMO interference channel defined in Section 3.2, the sum-DoF, d_Σ , satisfy the following outer bound for all $i, j \in \{1, 2\}$.*

$$d_\Sigma \leq \min(4D_1, 4D_2, 2M - |D_1 - D_2|) \qquad (3.5)$$

Remark: Note that the bounds have a dual character, i.e., the same bounds hold for the reciprocal network obtained by reversing the direction of communication.

Theorem 3.1 has profound implications in terms of the rank-matching phenomenon. However, we note that the theorem is obtained based only on arguments that are fairly standard for DoF bounds,

similar to, e.g., [39]. As such, this is a remarkable case of simple arguments leading to surprising insights. The proof of Theorem 3.1 is presented in Section 3.4.1.

3.3.2 Tightness of Rank-Mismatch Outer Bounds

Having presented the rank-mismatch outer bounds in Theorem 3.1, we next consider the natural question ‘How tight are these bounds?’. This seems to be a difficult question to answer in full generality due to the abundance of parameters. Nevertheless, for the symmetric setting illustrated in Fig. 3.1, where all channels in the first hop have rank D_1 and all channels in the second hop have rank D_2 , and all nodes have M antennas, we are able to prove that (combined with min-cut max-flow bounds) the rank-mismatch bounds are the best possible bounds for the given rank-constraints. By best possible we mean that 1) the bounds are satisfied by all channels that satisfy the rank-constraints, and 2) there exist channels that satisfy the given rank-constraints for which the bounds are tight. Not only that, but the bounds are tight for *almost all* channels that satisfy the rank-constraints, i.e., they are tight almost surely for generic channels, where by generic channels we mean that the channels are drawn according to a continuous distribution over the algebraic variety defined by the rank-constraints. For instance, one may assume that each $M \times M$ channel over the l -th hop is a product of an $M \times D_l$ channel matrix and a $D_l \times M$ channel matrix, each of which is generated randomly and independently of the others across space and time, according to a continuous distribution. We state this result as the following theorem.

THEOREM 3.2. *For the rank-constrained symmetric $2 \times 2 \times 2$ MIMO interference channel illustrated in Fig. 3.1 the sum-DoF outer bound $d_\Sigma \leq \min(4D_1, 4D_2, 2M - |D_1 - D_2|)$ is the best possible for the given rank-constraints. For generic time-varying channels, the bound is tight almost surely.*

The proof is presented in Section 3.4.2.

Note that the rank-mismatch bounds may no longer be tight if additional structure is imposed, e.g., through additional rank-constraints. However, subject only to the rank-constraints stated in (3.4), these bounds appear to be the best possible. In fact, for all the cases that we have considered so far, we have found these bounds to be the best possible when combined with min-cut max-flow bounds.

3.4 Proofs

3.4.1 Theorem 3.1 : Proof of Outer Bound

Proof: We begin with a change of basis operation (an invertible linear transformation that does not affect the DoF) along the lines of [55]. The subsequent genie-aided dimension counting arguments used for information theoretic outer bounds are consistent with the frameworks developed in [55].

Change of basis operation

The outcome of the change of basis operation is illustrated in Fig. 3.2 for the case where $D_l > \frac{M}{2}$. The change of basis for the case where $D_l \leq \frac{M}{2}$ is trivial because there is no overlap between the signal spaces accessed by channels from different nodes, so a complete orthogonalization of all 4 channels is possible. Here we describe the change of basis operation for the first hop, where $D_1 > \frac{M}{2}$. The change of basis for the second hop is very similar, with D_2 replacing D_1 , relays replacing transmitters, and destinations replacing relays.

Step 1: At each relay, the received signal is rotated such that the first $M - D_1$ antennas of relay k (denoted by ka) do not hear Transmitter $j, j \neq k$ and the last $M - D_1$ antennas of relay k (denoted

by kc) do not hear Transmitter k . This operation is guaranteed because of the rank-deficiency assumptions. The remaining $2D_1 - M$ antennas are denoted as kb .

Step 2: At transmitter k , $k \in \{1, 2\}$, there is a D_1 -dimensional transmit subspace orthogonal to $M - D_1$ relay antennas ka and another D_1 -dimensional subspace orthogonal to $M - D_1$ relay antennas $jc, j \neq k$. These two D_1 -dimensional subspaces have $2D_1 - M$ dimensional intersection within the M -dimensional space seen from the transmitter. The change of basis at transmitter k maps these $2D_1 - M$ dimensions to the $2D_1 - M$ antennas denoted as kb . Then, the first $M - D_1$ antennas of transmitter k are mapped to the space that is not heard by Relay $j, j \neq k$ and the last $M - D_1$ antennas of Transmitter k are mapped to the space not heard by Relay k . This operation is guaranteed again because of the rank deficiency assumptions.

Outer Bound

Region 1: $D_1 > \frac{M}{2}, D_2 > \frac{M}{2}$

(1.1) When $D_1 \leq D_2$: Let a genie provide $\mathcal{G}_1 = \{X_{2b}^n, X_{2c}^n, R_{2a}^n\}$ to Receiver 1, which has M antennas. The total number of dimensions available to Receiver 1 (including genie) is:

$$M + |\mathcal{G}_1| = M + |X_{2b}^n| + |X_{2c}^n| + |R_{2a}^n| = 2M - (D_2 - D_1) \quad (3.6)$$

Receiver 1 can decode its desired message W_1 and can obtain $X_{1a}^n, X_{1b}^n, X_{1c}^n$. Using genie information X_{2b}^n, X_{2c}^n , Receiver 1 can reconstruct the received signal at Relay 1 and obtain $R_{1a}^n, R_{1b}^n, R_{1c}^n$. This enables receiver 1 to remove $R_{1a}^n, R_{1b}^n, R_{1c}^n$ from the received signal and decode R_{2b}^n, R_{2c}^n . With additional genie information R_{2a}^n , Receiver 1 would be able to decode X_{2a}^n and as a result, decodes message W_2 (subject to noise distortion) sent from Transmitter 2. Hence, the sum DoF is bounded as $d_\Sigma \leq M + |\mathcal{G}_1| = 2M - (D_2 - D_1)$.

$M - D_1$	X_{1a}	o	o	$S_{1a}(X_{1a})$	$M - D_1$	$M - D_2$	R_{1a}	o	o	$Y_{1a}(R_{1a})$	$M - D_2$
$2D_1 - M$	X_{1b}	o	o	$S_{1b}(X_{1a}, X_{1b}, X_{2b}, X_{2c})$	$2D_1 - M$	$2D_2 - M$	R_{1b}	o	o	$Y_{1b}(R_{1a}, R_{1b}, R_{2b}, R_{2c})$	$2D_2 - M$
$M - D_1$	X_{1c}	o	o	$S_{1c}(X_{2c})$	$M - D_1$	$M - D_2$	R_{1c}	o	o	$Y_{1c}(R_{2c})$	$M - D_2$
$M - D_1$	X_{2a}	o	o	$S_{2a}(X_{2a})$	$M - D_1$	$M - D_2$	R_{2a}	o	o	$Y_{2a}(R_{2a})$	$M - D_2$
$2D_1 - M$	X_{2b}	o	o	$S_{2b}(X_{2a}, X_{2b}, X_{1b}, X_{1c})$	$2D_1 - M$	$2D_2 - M$	R_{2b}	o	o	$Y_{2b}(R_{2a}, R_{2b}, R_{1b}, R_{1c})$	$2D_2 - M$
$M - D_1$	X_{2c}	o	o	$S_{2c}(X_{1c})$	$M - D_1$	$M - D_2$	R_{2c}	o	o	$Y_{2c}(R_{1c})$	$M - D_2$

Figure 3.2: Change of Basis for Region 1. $D_1 > \frac{M}{2}, D_2 > \frac{M}{2}$

(1.2) When $D_1 > D_2$: Let a genie provide $\mathcal{G}_1 = \{X_{2c}^n, R_{2a}^n, R_{2b}^n\}$ to Receiver 1, which has M antennas. The total number of dimensions at Receiver 1 (including genie) is:

$$M + |\mathcal{G}_1| = M + |X_{2c}^n| + |R_{2a}^n| + |R_{2b}^n| = 2M - (D_1 - D_2) \quad (3.7)$$

Receiver 1 can decode its desired message W_1 and can obtain $X_{1a}^n, X_{1b}^n, X_{1c}^n$. Receiver 1 can decode R_{2c}^n using $M - D_2$ antennas. Using genie information R_{2a}^n, R_{2b}^n and decoded R_{2c}^n , Receiver 1 can reconstruct the received signal at Relay 2 and obtain X_{2a}^n, X_{2b}^n . With additional genie information X_{2c}^n , Receiver 1 would be able to decode message W_2 (subject to noise distortion) sent from Transmitter 2. Hence, the sum DoF is bounded as $d_\Sigma \leq M + |\mathcal{G}_1| = 2M - (D_1 - D_2)$.

Combining bounds of (1.1) and (1.2), we get the bound:

$$d_\Sigma \leq 2M - |D_1 - D_2| \quad (3.8)$$

Region 2: $D_1 \leq \frac{M}{2}, D_2 > \frac{M}{2}$

Let a genie provide $\mathcal{G}_1 = \{X_{2c}^n, R_{2a}^n\}$ to Receiver 1, which has M antennas. The total number of dimensions at Receiver 1 (including genie) is:

$$M + |\mathcal{G}_1| = M + |X_{2c}^n| + |R_{2a}^n| = 2M - (D_2 - D_1) \quad (3.9)$$

D_1	X_{1a}	\circ	\circ	$S_{1a}(X_{1a})$	D_1	$M - D_2$	R_{1a}	\circ	\circ	$Y_{1a}(R_{1a})$	$M - D_2$
$M - 2D_1$	X_{1b}	\circ	\circ	$S_{1b}()$	$M - 2D_1$	$2D_2 - M$	R_{1b}	\circ	\circ	$Y_{1b}(R_{1a}, R_{1b}, R_{2b}, R_{2c})$	$2D_2 - M$
D_1	X_{1c}	\circ	\circ	$S_{1c}(X_{2c})$	D_1	$M - D_2$	R_{1c}	\circ	\circ	$Y_{1c}(R_{2c})$	$M - D_2$
D_1	X_{2a}	\circ	\circ	$S_{2a}(X_{2a})$	D_1	$M - D_2$	R_{2a}	\circ	\circ	$Y_{2a}(R_{2a})$	$M - D_2$
$M - 2D_1$	X_{2b}	\circ	\circ	$S_{2b}()$	$M - 2D_1$	$2D_2 - M$	R_{2b}	\circ	\circ	$Y_{2b}(R_{2a}, R_{2b}, R_{1b}, R_{1c})$	$2D_2 - M$
D_1	X_{2c}	\circ	\circ	$S_{2c}(X_{1c})$	D_1	$M - D_2$	R_{2c}	\circ	\circ	$Y_{2c}(R_{1c})$	$M - D_2$

Figure 3.3: Change of Basis for Region 2. $D_1 \leq \frac{M}{2}, D_2 > \frac{M}{2}$

Receiver 1 can decode its desired message W_1 and can obtain $X_{1a}^n, X_{1b}^n, X_{1c}^n$. Using genie information X_{2c}^n , Receiver 1 can reconstruct the received signal at Relay 1 and obtain $R_{1a}^n, R_{1b}^n, R_{1c}^n$. This enables receiver 1 to remove $R_{1a}^n, R_{1b}^n, R_{1c}^n$ from the received signal and decode R_{2b}^n, R_{2c}^n . With additional genie information R_{2a}^n , Receiver 1 would be able to decode X_{2a}^n and as a result, decodes message W_2 (subject to noise distortion) sent from Transmitter 2. Hence, the sum DoF is bounded as $d_\Sigma \leq M + |\mathcal{G}_1| = 2M - (D_2 - D_1)$.

When $M > D_1 + D_2$, outer bound on the sum DoF is the same as the cutset bound, $d_\Sigma \leq 4D_1$. Hence, outer bound on the sum DoF for Region 2, is:

$$d_\Sigma \leq \min\{4D_1, 2M - (D_2 - D_1)\} \quad (3.10)$$

Region 3: $D_1 > \frac{M}{2}, D_2 \leq \frac{M}{2}$

Let a genie provide $\mathcal{G}_1 = \{X_{2c}^n, R_{2a}^n, R_{2b}^n\}$ to Receiver 1, which uses only $2D_2$ antennas. The total number of dimensions (including genie):

$$2D_2 + |\mathcal{G}_1| = 2D_2 + |X_{2c}^n| + |R_{2a}^n| + |R_{2b}^n| = 2M - (D_1 - D_2) \quad (3.11)$$

Receiver 1 can decode its desired message W_1 and can obtain $X_{1a}^n, X_{1b}^n, X_{1c}^n$. Receiver 1 can decode R_{2c}^n using D_2 antennas. Using genie information R_{2a}^n, R_{2b}^n and known R_{2c}^n , Receiver 1 can decode the received signal at Relay 2 and obtain X_{2a}^n, X_{2b}^n . With additional genie information

$M - D_1$	X_{1a}	\circ	\circ	$S_{1a}(X_{1a})$	$M - D_1$	D_2	R_{1a}	\circ	\circ	$Y_{1a}(R_{1a})$	D_2
$2D_1 - M$	X_{1b}	\circ	\circ	$S_{1b}(X_{1a}, X_{1b}, X_{2b}, X_{2c})$	$2D_1 - M$	$M - 2D_2$	R_{1b}	\circ	\circ	$Y_{1b}()$	$M - 2D_2$
$M - D_1$	X_{1c}	\circ	\circ	$S_{1c}(X_{2c})$	$M - D_1$	D_2	R_{1c}	\circ	\circ	$Y_{1c}(R_{2c})$	D_2
$M - D_1$	X_{2a}	\circ	\circ	$S_{2a}(X_{2a})$	$M - D_1$	D_2	R_{2a}	\circ	\circ	$Y_{2a}(R_{2a})$	D_2
$2D_1 - M$	X_{2b}	\circ	\circ	$S_{2b}(X_{2a}, X_{2b}, X_{1b}, X_{1c})$	$2D_1 - M$	$M - 2D_2$	R_{2b}	\circ	\circ	$Y_{2b}()$	$M - 2D_2$
$M - D_1$	X_{2c}	\circ	\circ	$S_{2c}(X_{1c})$	$M - D_1$	D_2	R_{2c}	\circ	\circ	$Y_{2c}(R_{1c})$	D_2

Figure 3.4: Change of Basis for Region 3. $D_1 > \frac{M}{2}, D_2 \leq \frac{M}{2}$

X_{2c}^n , Receiver 1 can decode the message W_2 (subject to noise distortion) sent from Transmitter 2.

Hence, the sum DoF is bounded as $d_\Sigma \leq M + |\mathcal{G}_1| = 2M - (D_1 - D_2)$.

When $M > D_1 + D_2$, outer bound on the sum DoF is the same as the cutset bound, $d_\Sigma \leq 4D_2$.

Hence, outer bound on the sum DoF for Region 3, is :

$$d_\Sigma \leq \min\{4D_2, 2M - (D_1 - D_2)\} \quad (3.12)$$

Region 4: $D_1 \leq \frac{M}{2}, D_2 \leq \frac{M}{2}$

In this region, DoF outer bound is the same as the min-cut, $d_\Sigma \leq \min(4D_1, 4D_2)$.

3.4.2 Theorem 3.2 : Proof of Achievability

First, notice that the outer bound $\min(4D_1, 4D_2, 2M - |D_1 - D_2|)$ is valid. The first two terms are min-cut max-flow bounds and the last term follows from Theorem 3.1.

As we will use linear schemes, which satisfy duality, we may assume $D_1 \leq D_2$ without any loss of generality. In this case, the outer bound simplifies to $\min(4D_1, 2M - (D_2 - D_1))$.

For different configurations of M, D_1, D_2 , both the outer bound and the channel constructed may vary. As such, based on relationship between M, D_1 and D_2 , we divide the total parameter space into 4 disjoint regimes (see Fig. 3.5). We will first show for each regime, that there exist channels

that satisfy all rank-constraints, for which the outer bound is tight. We will conclude with the generalization that the bound is tight almost surely for generic channels.

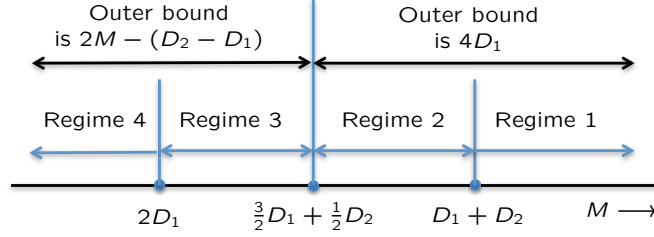

Figure 3.5: 2-hop interference channel : 4 Regimes

The real axis is partitioned into 4 intervals, $(-\infty, 2D_1)$, $(2D_1, \frac{3}{2}D_1 + \frac{1}{2}D_2)$, $(\frac{3}{2}D_1 + \frac{1}{2}D_2, D_1 + D_2)$, $(D_1 + D_2, +\infty)$. Depending on which interval M falls into, we have 4 regimes. For Regimes 1 and 2, the outer bound is $4D_1$ and for Regimes 3 and 4, the outer bound is $2M - (D_2 - D_1)$. Note that by the definition of rank, $M \geq D_2 \geq D_1$, so we only consider those parameter regimes where this condition is true.

- **Regime 1** ($D_1 + D_2 \leq M$): The constructed channel appears in Fig. 3.6. The connectivity is simple. The sources are connected to the relays with 4 orthogonal links. The relays are connected to the destinations with 4 orthogonal links and possibly a fully connected 2×2 subnetwork. For the channels that are shown as connected, one may choose the coefficients to be generic, that is, each non-zero channel coefficient is drawn independently from some continuous distribution bounded away from zero and infinity to avoid degenerate scenarios. For example, the first D_1 antennas of \mathcal{S}_1 are connected to the first D_1 antennas of \mathcal{R}_1 with a generic $D_1 \times D_1$ (specifically, rank D_1) MIMO channel. We keep this assumption that every connected channel coefficient is generic for other regimes as well. Note that all rank conditions are satisfied. Over such a channel, it is easy to achieve the outer bound, $4D_1$, as $\min(D_2, M - D_2) \geq D_1$ such that we can always route the messages over orthogonal links, by standard point to point MIMO capacity achieving schemes.
- **Regime 2** ($\frac{3}{2}D_1 + \frac{1}{2}D_2 \leq M < D_1 + D_2$): The channel we construct is shown in Fig. 3.7. The connectivity is same as Fig. 3.6. The outer bound is still $4D_1$. In order to achieve that, pure routing will not suffice as each orthogonal link on the second hop only has DoF

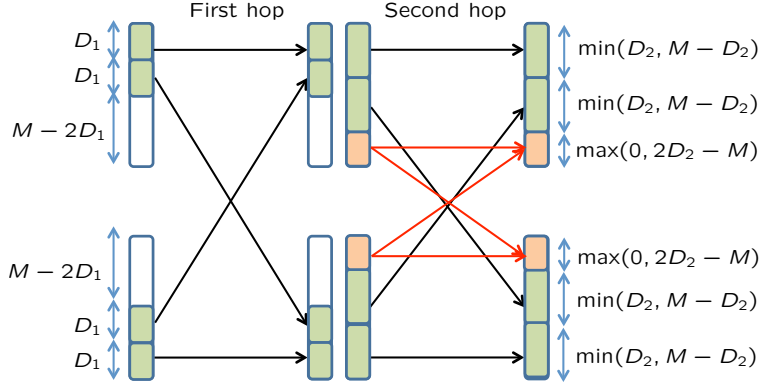

Figure 3.6: Constructed channel for Regime 1

For clarity, the relay nodes are shown twice, one for the channels (receive side) of the first hop, the other for the channels (transmit side) of the second hop.

$M - D_2$, which can not support D_1 DoF, as in this regime, $D_1 > M - D_2$. As a result, we have to use the fully connected 2×2 subnetwork on the second hop. The new idea here is viewing that as a 2×2 X network with $2D_2 - M$ antennas at each node, whose sum-DoF value is given by $\frac{4}{3}(2D_2 - M)$ [28]. Then as long as $4[D_1 - (M - D_2)]$, the total DoF that we fail to route to desired destinations, is smaller than $\frac{4}{3}(2D_2 - M)$, we are able to utilize the interference alignment scheme over X network to send the remaining $4[D_1 - (M - D_2)]$ DoF. We have

$$4[D_1 - (M - D_2)] \leq \frac{4}{3}(2D_2 - M) \Leftrightarrow 2M \geq 3D_1 + D_2 \quad (3.13)$$

which is satisfied in Regime 2. Therefore the scheme works.

- **Regime 3** ($2D_1 \leq M < \frac{3}{2}D_1 + \frac{1}{2}D_2$): The channel is same as that used in Regime 2 (see Fig. 3.7). Here the outer bound is $2M - (D_2 - D_1) < 4D_1$. Note that in Regime 2, we have already saturated the fully connected 2×2 subnetwork by employing it as an X network to the most. It may seem impossible to get something more. But thanks to the outer bound, we are not achieving $4D_1$ DoF, which means that the first hop has left capability. If we send same information from a source to both relays, the second hop can be employed as a broadcast channel (BC). Thus there exists a tradeoff, between employing the second hop

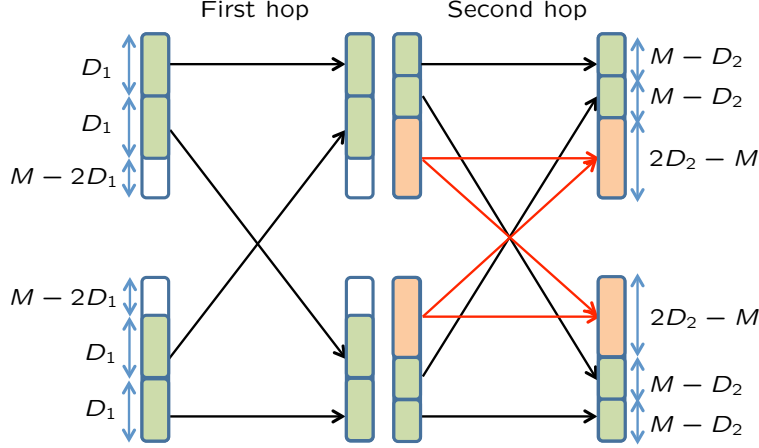

Figure 3.7: Constructed channel for Regimes 2 and 3

The channel is almost the same that in Fig. 3.6, where the only difference is that $M - D_2$ is smaller instead of bigger than D_1 . To highlight such an important distinction which demands the use of X scheme, we redraw the channel here.

as an X network or a BC. X scheme costs less on first hop but achieves fewer DoF on the second hop, while broadcast scheme achieves more DoF on the second hop but consumes more on the first hop. To determine the optimal ratio between them, we assume the second hop uses the X scheme for f_X fraction of time and the broadcast scheme for f_{BC} fraction of time. Naturally, we have

$$f_X + f_{BC} = 1. \quad (3.14)$$

Note that for the fully connected 2×2 subnetwork, broadcast scheme has $2(2D_2 - M)$ DoF and X scheme has $\frac{4}{3}(2D_2 - M)$ DoF. Then by using X scheme f_X fraction of time and broadcast scheme f_{BC} fraction of time, we need to have $2f_{BC}(2D_2 - M) + \frac{4}{3}f_X(2D_2 - M)$ DoF to send at the relays, which are received from the first hop. The broadcast messages need to be present at both relays and X messages need only be at one relay, so we need to send a total of $4f_{BC}(2D_2 - M) + \frac{4}{3}f_X(2D_2 - M)$ DoF over the first hop, which should equal its capability, $4D_1 - 4(M - D_2)$. Note that $4(M - D_2)$ DoF are occupied for routing

messages to be sent over orthogonal links on the second hop. Therefore, we have

$$4f_{BC}(2D_2 - M) + \frac{4}{3}f_X(2D_2 - M) = 4D_1 - 4(M - D_2). \quad (3.15)$$

Combining (3.14)(3.15), we have

$$f_X = \frac{\frac{3}{2}(D_2 - D_1)}{2D_2 - M}, f_{BC} = \frac{\frac{1}{2}(3D_1 + D_2 - 2M)}{2D_2 - M},$$

such that the DoF value achieved by X and broadcast schemes in total is

$$2f_{BC}(2D_2 - M) + \frac{4}{3}f_X(2D_2 - M) = 3D_1 + D_2 - 2M + 2(D_2 - D_1) = D_1 + 3D_2 - 2M.$$

Adding up with $4(M - D_2)$ routing DoF, we get $2M - (D_2 - D_1)$, as desired.

- **Regime 4 ($M < 2D_1$):** The constructed channel appears in Fig. 3.8. We want to show that the outer bound, $2M - (D_2 - D_1)$, is achievable. The new element here is that the first hop itself contains a fully connected subnetwork. To utilize this, we pair it with the second hop to get a $2 \times 2 \times 2$ MIMO full rank interference channel with $2D_1 - M$ antennas everywhere. By aligned interference neutralization (AIN), we achieve $2(2D_1 - M)$ DoF [22]. Then the fully connected subnetwork on the second hop is split into 2 parallel subnetworks. Similar as before, we route $4(M - D_2)$ DoF which saturates the orthogonal links on the second hop. We are left to use the fully connected 2×2 subnetwork with $2(D_2 - D_1)$ antennas at each node on the second hop. The first hop has unused DoF $4(M - D_1) - 4(M - D_2) = 4(D_2 - D_1)$, after AIN and routing. Here we also need to decide how to share the second hop with X and broadcast schemes. Then following similar logic, we have

$$f_X + f_{BC} = 1 \quad (3.16)$$

$$\frac{8}{3}(D_2 - D_1)f_X + 8(D_2 - D_1)f_{BC} = 4(D_2 - D_1) \quad (3.17)$$

Table 3.1: DoF achieved by each scheme in different regimes

Regimes	AIN	BC	X	Routing	Total DoF
$D_1 + D_2 \leq M$	0	0	0	$4D_1$	$4D_1$
$\frac{3}{2}D_1 + \frac{1}{2}D_2 \leq M < D_1 + D_2$	0	0	$4(D_1 + D_2 - M)$	$4(M - D_2)$	$4D_1$
$2D_1 \leq M < \frac{3}{2}D_1 + \frac{1}{2}D_2$	0	$3D_1 + D_2 - 2M$	$2(D_2 - D_1)$	$4(M - D_2)$	$2M - (D_2 - D_1)$
$M < 2D_1$	$2(2D_1 - M)$	$D_2 - D_1$	$2(D_2 - D_1)$	$4(M - D_2)$	$2M - (D_2 - D_1)$

from which we can solve $f_X = \frac{3}{4}, f_{BC} = \frac{1}{4}$ such that the DoF value achieved is $D_2 - D_1$ by broadcast scheme and $2(D_2 - D_1)$ by X scheme. Adding up with those achieved by AIN and routing, we get $2(2D_1 - M) + 4(M - D_2) + (D_2 - D_1) + 2(D_2 - D_1) = 2M - (D_2 - D_1)$, as desired.

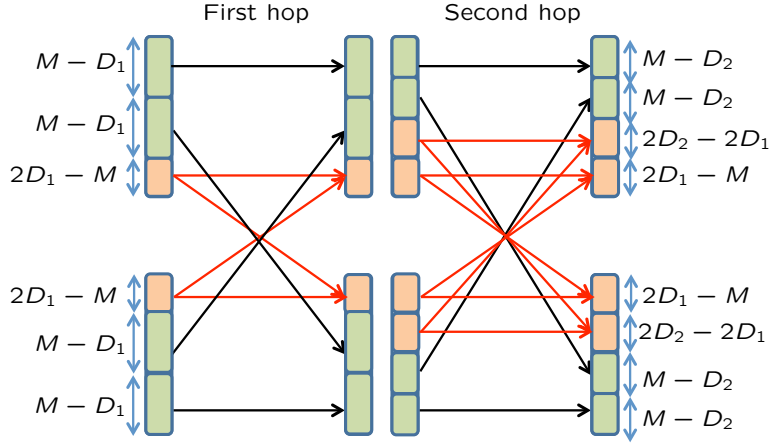

Figure 3.8: Constructed channel for Regime 4.

As a summary, we list the achievable scheme used and corresponding DoF achieved in Table 3.1.

Finally, we consider fully generic channels, guided by insights from specific channel constructions presented for each of the regimes. In particular, we will show that through proper precoding, we can essentially create the specific channel constructed above such that the achievable scheme with DoF allocation as specified in Table I obtains the outer bound. Similarly, we have 4 regimes.

- Regime 1 ($D_1 + D_2 \leq M$): We consider the first hop. Referring to Fig. 3.6, we want to create 4 orthogonal links, one from each source to each relay. Towards this end, we will

choose 4 $M \times D_1$ precoding matrices, \mathbf{V}_{ZF11}^1 , \mathbf{V}_{ZF21}^1 , \mathbf{V}_{ZF12}^1 and \mathbf{V}_{ZF22}^1 as follows.

$$\mathbf{V}_{ZF11}^1 \subseteq \mathcal{N}(\mathbf{H}_{21}^1), \mathbf{V}_{ZF21}^1 \subseteq \mathcal{N}(\mathbf{H}_{11}^1) \quad (3.18)$$

$$\mathbf{V}_{ZF12}^1 \subseteq \mathcal{N}(\mathbf{H}_{22}^1), \mathbf{V}_{ZF22}^1 \subseteq \mathcal{N}(\mathbf{H}_{12}^1) \quad (3.19)$$

where $\mathcal{N}(\mathbf{A})$ denotes the right null space of matrix \mathbf{A} . Note that $\mathbf{V}_{ZFji}^1, i \in \{1, 2\}, j \in \{1, 2\}$ is used by \mathcal{S}_i , for \mathcal{R}_j in the sense $\mathcal{R}_{\bar{j}}$ is zero forced. As the generic channel \mathbf{H}_{ji}^1 has rank D_1 such that $\dim(\mathcal{N}(\mathbf{H}_{ji}^1)) = M - D_1$ and $2D_1 \leq D_1 + D_2 \leq M$, such \mathbf{V}_{ZFji}^1 exist. Moreover, at \mathcal{S}_i , the precoding matrix $[\mathbf{V}_{ZF1i}^1 \ \mathbf{V}_{ZF2i}^1]$ has full rank as the two components are null spaces of generic channel matrices and the sum of their dimensions, $2D_1$ is smaller than the total space size, M . At \mathcal{R}_j , the receive signal space $[\mathbf{H}_{j1}^1 \mathbf{V}_{ZFj1}^1 \ \mathbf{H}_{j2}^1 \mathbf{V}_{ZFj2}^1]$ also has full rank as $\mathbf{H}_{ji}^1 \mathbf{V}_{ZFji}^1$ is a subspace of \mathbf{H}_{ji}^1 and the column spaces of two generic matrices \mathbf{H}_{j1}^1 and \mathbf{H}_{j2}^1 (with rank D_1 each) do not intersect in an M dimensional space, since $2D_1 \leq M$. This process creates 4 orthogonal links.

The second hop is similar to the first hop. We choose precoding matrices at the relays such that undesired destination is zero forced. The linear independence of vectors of precoding matrix at the relay and receive signal space at the destination can be similarly proved. After creating such orthogonal links as in Fig. 3.6, we can use routing to achieve the desired $4D_1$ DoF.

- Regime 2 ($\frac{3}{2}D_1 + \frac{1}{2}D_2 \leq M < D_1 + D_2$): The first hop is same as Regime 1, using null spaces to create orthogonal links. On the second hop, \mathcal{R}_i uses following precoding matrix

\mathbf{V}_i^2 of size $M \times 2D_1$.

$$\mathbf{V}_1^2 = [\mathbf{V}_{ZF11}^2 \quad \mathbf{V}_{ZF21}^2 \quad \mathbf{V}_{X11}^2 \quad \mathbf{V}_{X21}^2] \quad (3.20)$$

$$\mathbf{V}_2^2 = [\mathbf{V}_{ZF12}^2 \quad \mathbf{V}_{ZF22}^2 \quad \mathbf{V}_{X12}^2 \quad \mathbf{V}_{X22}^2] \quad (3.21)$$

$$\dim(\mathbf{V}_{ZFji}^2) = M - D_2 \quad (3.22)$$

$$\dim(\mathbf{V}_{Xji}^2) = D_1 + D_2 - M \quad (3.23)$$

wherein $\mathbf{V}_{ZFji}^2 = \mathcal{N}(\mathbf{H}_{ji}^2)$, and \mathbf{V}_{Xji}^2 are chosen such that the following X network alignment conditions are satisfied.

$$\mathbf{H}_{11}^2 \mathbf{V}_{X21}^2 = -\mathbf{H}_{12}^2 \mathbf{V}_{X22}^2 \subseteq \mathbf{H}_{11}^2 \cap \mathbf{H}_{12}^2 \quad (3.24)$$

$$\mathbf{H}_{21}^2 \mathbf{V}_{X11}^2 = -\mathbf{H}_{22}^2 \mathbf{V}_{X12}^2 \subseteq \mathbf{H}_{21}^2 \cap \mathbf{H}_{22}^2 \quad (3.25)$$

Note that

$$\dim(\mathbf{H}_{11}^2 \cap \mathbf{H}_{12}^2) = \dim(\mathbf{H}_{21}^2 \cap \mathbf{H}_{22}^2) = 2D_2 - M \geq D_1 + D_2 - M = \dim(\mathbf{V}_{Xji}^2) \quad (3.26)$$

then \mathbf{V}_{Xji}^2 exist. With vectors chosen in this way, at \mathcal{R}_i , the precoding matrix \mathbf{V}_i^2 has $2D_1 \leq M$ linear independent columns. The signal space matrix at \mathcal{D}_1 is given as

$$[\mathbf{H}_{11}^2 \mathbf{V}_1^2 \quad \mathbf{H}_{12}^2 \mathbf{V}_2^2] = [\mathbf{H}_{11}^2 \mathbf{V}_{ZF11}^2 \quad \mathbf{H}_{12}^2 \mathbf{V}_{ZF12}^2 \quad \mathbf{H}_{11}^2 \mathbf{V}_{X11}^2 \quad \mathbf{H}_{12}^2 \mathbf{V}_{X12}^2 \quad \mathbf{H}_{11}^2 \mathbf{V}_{X21}^2 \quad \mathbf{H}_{12}^2 \mathbf{V}_{X22}^2] \quad (3.27)$$

which has $2(M - D_2) + 3(D_1 + D_2 - M) = 3D_1 + D_2 - M \leq M$ vectors such that it has full rank, since the transmitted vectors are independent and pass through channels that are generic. Similarly, the signal space matrix at \mathcal{D}_2 also has full rank. We can now use the first hop to transmit $4D_1$ DoF to the relays which then use a combination of zero forcing and X scheme with precoding matrices as above to send these DoF to the destinations.

- **Regime 3** ($2D_1 \leq M < \frac{3}{2}D_1 + \frac{1}{2}D_2$): The first hop is still the same and we have 4 orthogonal links with sum-DoF $4D_1$. According to Table I, to each relay, we will send $3D_1 + D_2 - 2M$ DoF of common message, $(D_2 - D_1)$ DoF which will utilize X scheme and $2(M - D_2)$ DoF which will be sent by zero forcing, over the second hop. This is possible since $2(3D_1 + D_2 - 2M) + 2(D_2 - D_1) + 4(M - D_2) = 4D_1$, which is supportable on the first hop. At each relay, the zero forcing and X precoding vectors will be chosen the same as Regime 2. The precoding vectors for broadcast scheme are the same as X , by noting that for the solution of (3.24)(3.25), if we are transmitting the same message out, the interference caused to the undesired destination is nulled (instead of aligned as in X network). At each destination, the received signal consists of $2(M - D_2)$ zero forcing vectors, $\frac{3}{2}(D_2 - D_1)$ X beamformed vectors ($\frac{2}{3}$ of which are desired and the other $\frac{1}{3}$ interfering) and $\frac{1}{2}(3D_1 + D_2 - 2M)$ broadcast vectors, for a total of M . Linear independency at the relays and destinations follow similarly.
- **Regime 4** ($M < 2D_1$): On the first hop, in order to create the fully connected 2×2 sub-network as in Fig. 3.8, we prove that there exist two $M \times (2D_1 - M)$ matrices $\mathbf{U}_1^1, \mathbf{U}_2^1$ such that

$$\mathbf{H}_{11}^1 \mathbf{U}_1^1 = \mathbf{H}_{12}^1 \mathbf{U}_2^1 \quad (3.28)$$

$$\mathbf{H}_{21}^1 \mathbf{U}_1^1 = \mathbf{H}_{22}^1 \mathbf{U}_2^1 \quad (3.29)$$

Note the difference with (3.24) (3.25) where the precoding vectors are different in the two equations. For the solution of (3.28), the basis of \mathbf{U}_1^1 has rank D_1 , $D_1 - M$ of which will have $\mathbf{H}_{11}^1 \mathbf{U}_1^1 = 0$ and the remaining $2D_1 - M$ will produce $\mathbf{H}_{11}^1 \mathbf{U}_1^1 = \mathbf{H}_{11}^1 \cap \mathbf{H}_{12}^1$. Similarly, for the solution of (3.29), \mathbf{U}_1^1 has rank D_1 . These two D_1 dimensional spaces will intersect in a $2D_1 - M$ dimensional space, which is the solution that we seek since it satisfies both equations. Similar solution can be found for \mathbf{U}_2^1 as well. Thus, we have found two $2D_1 - M$ dimensional spaces, one at each relay, that are accessible by the same space at each source. This gives us a fully connected subnetwork. Inside such a $2D_1 - M$ dimensional space, we

design an AIN solution as proposed in [22], where \mathcal{S}_1 sends $p \triangleq 2D_1 - M$ symbols with p precoding vectors $\mathbf{v}_{AIN1,1}^1, \dots, \mathbf{v}_{AIN1,p}^1$ and \mathcal{S}_2 sends $2D_1 - M - 1 = p - 1$ symbols with $p - 1$ precoding vectors $\mathbf{v}_{AIN2,1}^1, \dots, \mathbf{v}_{AIN2,p-1}^1$. Each precoding vector has size $M \times 1$. The alignment relationship is same as that used in [22] (see Table I of [22]). At \mathcal{R}_1 , we have

$$\mathbf{H}_{11}^1 \mathbf{v}_{AIN1,q+1}^1 = \mathbf{H}_{12}^1 \mathbf{v}_{AIN2,q}^1, \quad q = 1, \dots, p - 1 \quad (3.30)$$

and at \mathcal{R}_2

$$\mathbf{H}_{21}^1 \mathbf{v}_{AIN1,q}^1 = \mathbf{H}_{22}^1 \mathbf{v}_{AIN2,q}^1, \quad q = 1, \dots, p - 1 \quad (3.31)$$

Here to find a solution, we will start from a random 1 dimensional subspace of \mathbf{U}_1^1 and set it as $\mathbf{v}_{AIN1,1}^1$, then go through (3.30)(3.31) to find all other vectors. Note that as $p = 2D_1 - M$, we are guaranteed to find such independent vectors. By a similar aligned neutralization design on the second hop (see Table II of [22]), we are able to send $2p - 1 = 2(2D_1 - M) - 1$ DoF with AIN. By considering a k -symbol extension, we can send $2k(2D_1 - M) - 1$ symbols over such symbol-extended network by AIN, resulting in $2(2D_1 - M)$ DoF asymptotically. All other symbols are sent by BC, X and routing (over zero forced orthogonal links) as specified in Table I. The operations that create these equivalent channels are the same as Regime 3. This completes the description of the achievable scheme for generic channels.

3.5 Summary

Rank-matching principle was identified for the 2-hop rank deficient interference channel, similar to impedance matching, wherein $2M$ DoF are achievable when channel ranks across both hops are the same. Under moderate rank deficiencies, DoF loss was found to be rank mismatch between the two hops. Although the focus of this work is primarily on the 2-hop rank deficient interference channel,

its fundamental nature leads to broad applicability in general multiframe multihop networks, as evident from the various extensions considered in the previous section. Furthermore, note that the rank-matching bounds are not limited to wireless networks. Indeed, as is the case with most DoF results, the same bounds are applicable to the deterministic counterparts of wireless networks over finite fields [34, 24, 30]. As such, they seem particularly useful to go beyond the Precoding-Based-Network-Alignment (PBNA) paradigm considered in [43, 37]. In PBNA a multiple unicast network is reduced to a single hop deterministic counterpart of a wireless interference network by allowing only linear operations (e.g., random linear network coding) at intermediate nodes, whereas all the intelligence lies at the source and destination nodes. As a step beyond PBNA one could allow some intelligence at a subset of the intermediate relay nodes. For example, in a 2-unicast PBNA framework, (or a K -unicast setting which is reduced to 2-unicast by clustering of nodes) one could select 2 MIMO relay nodes, either because these nodes exist as such or by clustering, such that the network reduces to a $2 \times 2 \times 2$ layered MIMO interference network. Since the structure of the network is reflected in the rank deficiencies of the constituent channels, the rank-matching bounds are applicable and may lead to new insights.

Chapter 4

Constant Finite field channels over \mathbb{F}_{p^n}

4.1 Motivations

Precoding based network alignment (PBNA) is a network communication paradigm inspired by linear network coding and interference alignment principles [43, 38, 16]. While intermediate nodes only perform arbitrary linear network coding operations which transform the network into a one-hop linear finite field network, all the intelligence resides at the source and destination nodes where information theoretically optimal encoding (precoding) and decoding is performed to achieve the capacity of the resulting linear network. The two restricting assumptions — restricting the intelligence to the source and destination nodes, and restricting to linear operations at intermediate nodes — are motivated by the reduced complexity of network optimization and also by the potential to apply the insights and techniques developed for one-hop wireless networks. Indeed, the PBNA paradigm gives rise to settings that are analogous to 1-hop wireless networks, albeit over finite fields. To highlight this distinction, we simply refer to these networks as finite field networks. There is a finite field counterpart to every 1-hop wireless network and vice versa. A number of interesting interference alignment techniques have been developed for 1-hop wireless networks and

shown to be optimal from a degrees of freedom (DoF) perspective. Translating the DoF optimal schemes for wireless networks into capacity optimal schemes for finite field networks is therefore a promising research avenue. For example, the CJ scheme originally conceived for the K user *time-varying* wireless interference channel in [9] is applied to the 3 unicast problem by Das et al. in [43, 38, 16]. While the CJ scheme has also been applied successfully to the constant channel setting in wireless networks by using the rational dimensions framework of Motahari et al. in [40], the constant channel setting remains much less understood. In this work, we study constant channel settings, but over the finite field \mathbb{F}_{p^n} .

The main contributions of this work are general insights into the correspondence between degrees of freedom of wireless networks and capacity or linear capacity results for their finite field counterparts. In the wireless setting, constant scalar (SISO) channels are challenging because they lack the diversity needed for linear interference alignment schemes. Constant finite-field channels over \mathbb{F}_{p^n} however, can be naturally treated as non-trivial $n \times n$ MIMO channels. A single link over \mathbb{F}_{p^n} has capacity $n \log(p)$, similar to n channels of capacity $\log(p)$ each. There is an immediate analogy to n parallel wireless channels which would have a first order capacity $\approx n \log(\text{SNR})$, establishing a correspondence between n and “diversity” (number of parallel channels) and between p and SNR. Indeed, while scalar channels in \mathbb{F}_{p^n} can be treated as $n \times n$ MIMO channels over the base field \mathbb{F}_p , these channels exist in a space with diversity limited to n , i.e., any $n + 1$ of these $n \times n$ channel matrices are linearly dependent over \mathbb{F}_p . Also, because of their special structure these channel matrices satisfy the commutative property of multiplication (inherited from the commutative property of multiplication in \mathbb{F}_{p^n}). Contrast this with generic $n \times n$ MIMO channels in \mathbb{F}_p , which occupy a space of diversity n^2 and generally do not commute. The difference is consistent with the interpretation of \mathbb{F}_{p^n} channels as similar to diagonal channels which have diversity only n , and are also commutative. These insights are affirmed by translating the DoF results from fixed diversity wireless networks to their \mathbb{F}_{p^n} counterparts. Especially in the 3 user interference channel, the role of n as the channel diversity becomes clear.

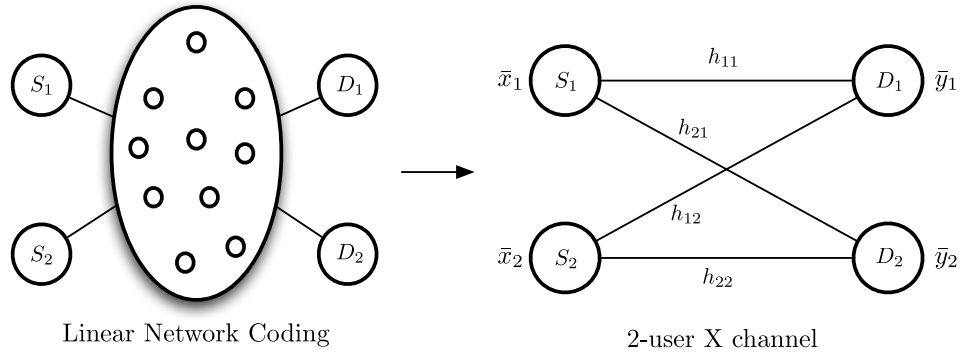

Figure 4.1: Wired network modeled as 2-user X channel

Other interesting aspects of this work are finer insights into linear interference alignment and the techniques used to prove resolvability of desired signals from interference. Whereas in wireless networks, linear interference alignment is feasible for either almost all channel realizations or almost none of them and is relevant primarily to the slope of the capacity curve in the infinite SNR (DoF) limit, in the finite field setting the fraction of channels where linear alignment is feasible can be a non-trivial function of p , so that not only we have the $p \rightarrow \infty$ behavior which corresponds to the wireless DoF results, but also we have an explicit dependence of linear alignment feasibility on p for finite values of p . By analogy to finite SNR, this is intriguing for its potential implications, even if the analogy is admittedly tenuous at this point. Since these finer insights are a priority in this work, we will not rely only on $p \rightarrow \infty$ assumptions to establish the capacity of the finite field networks. Instead, our goal will be to identify the capacity for all p as much as possible. Because of this focus on constant channels and finite p , the linear independence arguments required to show resolvability of desired and interfering signals, become a bit more challenging for finite p , and require a different, somewhat novel approach. Finally, while we focus primarily on the X channel and 3 user interference channel to reveal the key insights, the insights seem to be broadly applicable and sufficient for extensions beyond these settings.

We begin with the X channel.

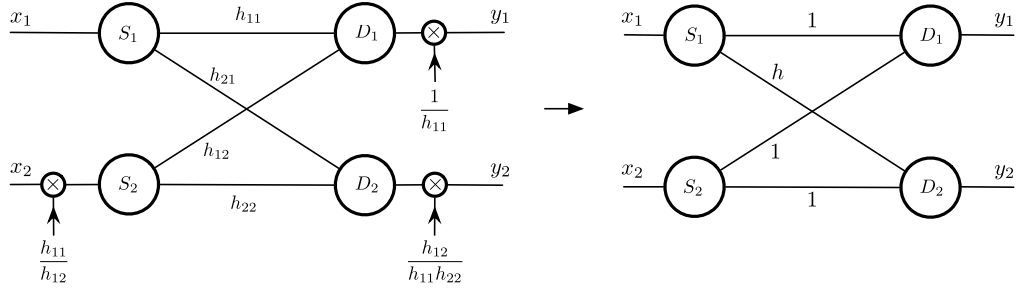

Figure 4.2: Normalization in X channel

4.2 X Channel

An X network is an all-unicast setting, i.e., there is an independent message from each source node to each destination node. In this work we study an X network with 2 source nodes, 2 destination nodes, and 4 independent messages as illustrated in Fig. 4.1, also known simply as the X channel.

4.2.1 Prior Work

The X channel, which contains broadcast, multiple access and interference channels as special cases, is one of the simplest, and also one of the earliest settings for interference alignment in wireless networks [35, 28]. With A antennas at each node, and constant channels, the achievability of $\lfloor \frac{4A}{3} \rfloor$ DoF was shown by Maddah-Ali, Motahari and Khandani in [35]. Jafar and Shamai showed in [28] that $\frac{4A}{3}$ DoF were achievable when $M > 1$ for constant channels, and also proved that this was the information theoretic outer bound for all M . For the scalar (SISO) case, i.e., $M = 1$, Jafar and Shamai showed that $\frac{4}{3}$ DoF were achievable when the channels were time-varying. The DoF of the SISO case with constant and complex channels were settled in [12] by Cadambe, Jafar and Wang, who introduced asymmetric complex signaling, also known as improper Gaussian signaling and showed that it achieves the optimal value of $\frac{4}{3}$ for the complex SISO X channel. The SISO case with constant and real coefficients was shown to achieve the optimal value of $\frac{4}{3}$ DoF in [40] by Motahari, Gharan and Khandani, who introduced a real interference alignment framework based

on rational-independence and diophantine approximation theory. Generalized degrees of freedom (GDoF) results for a symmetric SISO real constant X channel were obtained in [25] by Huang, Jafar and Cadambe, who also found a sufficient condition under which treating interference as noise is capacity optimal in the fully asymmetric case. A capacity approximation for the real SISO constant X channel within a constant gap, subject to a small outage set, was obtained by Niesen and Maddah-Ali in [42] using a novel deterministic channel model. For X networks, i.e., with arbitrary number (M) of transmitters and arbitrary number (N) of receivers, Cadambe and Jafar show in [10] that the SISO setting with time-varying channel coefficients has $\frac{MN}{M+N-1}$ DoF. The result is extended to the real constant SISO setting using the rational independence framework by Motahari et al. in [40]. Partial characterizations of the DoF region are found by Wang in [59]. Cadambe and Jafar show in [14] that the DoF value remains unchanged when relays and feedback are included. DoF of the time-varying MIMO X channel with $A > 1$ antennas at each node are settled in [51] by Sun et al. who identify a one-sided decomposability property of X networks, and show that the spatial scale invariance conjecture of Wang, Gou and Jafar [55] (that the DoF scale with the number of antennas) holds in this case. The DoF of a layered multihop SISO X channel with 2 source nodes and 2 destination nodes are characterized in [54] by Wang, Gou and Jafar, who show that the DoF can only take the values $1, \frac{4}{3}, \frac{3}{2}, \frac{5}{3}, 2$ and identify the networks that correspond to each value. Note that all the DoF results mentioned above are meant in the ‘almost surely’ sense, i.e., they hold for almost all channel realizations but in every case there are channels for which the DoF remain unknown. The problem is particularly severe for rational alignment and diophantine approximation based schemes for real constant channels, where while the DoF value applicable to almost all channels is known, the DoF of any given channel realization is unknown for almost all channel realizations.

For wired networks, if intermediate nodes are intelligent, i.e., operations at intermediate nodes can be optimized, then the sum-capacity of an all-unicast network, i.e., an X network, has been shown to be achievable by routing [54]. However, due to practical limitations, optimization of intermediate nodes may not be possible. While the overhead and complexity of learning and

optimizing individual coding coefficients at all intermediate nodes may be excessive, it is much easier to learn only the end-to-end channel coefficients, e.g., through network tomography, with no knowledge of the internal structure of the network or the individual coding coefficients at the intermediate nodes. This is the setting that we explore in this work.

4.2.2 Finite Field X Channel Model

Consider the finite field X channel

$$\bar{y}_1(t) = h_{11}\bar{x}_1(t) + h_{12}\bar{x}_2(t) \quad (4.1)$$

$$\bar{y}_2(t) = h_{22}\bar{x}_2(t) + h_{21}\bar{x}_1(t) \quad (4.2)$$

where, over the t^{th} channel use, $\bar{x}_i(t)$ is the symbol sent by source i , h_{ji} represents the channel coefficient between source i and destination j and \bar{y}_j represents the received symbol at destination j . All symbols $\bar{x}_i(t), h_{ji}, \bar{y}_j(t)$ and addition and multiplication operations are in a finite field \mathbb{F}_{p^n} . The channel coefficients h_{ji} are constant and assumed to be perfectly known at all sources and destinations. There are four independent messages, with W_{ji} denoting the message that originates at source i and is intended for destination j .

A coding scheme over T channel uses, that assigns to each message W_{ji} a rate R_{ji} , measured in units of \mathbb{F}_{p^n} symbols per channel use, corresponds to an encoding function at each source i that maps the messages originating at that source into a sequence of T transmitted symbols, and a decoding function at each destination j that maps the sequence of T received symbols into decoded

messages \hat{W}_{ji} .

$$\text{Encoder 1: } (W_{11}, W_{21}) \rightarrow \bar{x}_1(1)\bar{x}_1(2) \cdots \bar{x}_1(T) \quad (4.3)$$

$$\text{Encoder 2: } (W_{12}, W_{22}) \rightarrow \bar{x}_2(1)\bar{x}_2(2) \cdots \bar{x}_2(T) \quad (4.4)$$

$$\text{Decoder 1: } \bar{y}_1(1)\bar{y}_1(2) \cdots \bar{y}_1(T) \rightarrow (\hat{W}_{11}, \hat{W}_{12}) \quad (4.5)$$

$$\text{Decoder 2: } \bar{y}_2(1)\bar{y}_2(2) \cdots \bar{y}_2(T) \rightarrow (\hat{W}_{21}, \hat{W}_{22}) \quad (4.6)$$

Each message W_{ji} is uniformly distributed over $\{1, 2, \dots, [p^{nTR_{ji}}]\}$, $\forall i, j \in \{1, 2\}$. An error occurs if $(\hat{W}_{11}, \hat{W}_{12}, \hat{W}_{21}, \hat{W}_{22}) \neq (W_{11}, W_{12}, W_{21}, W_{22})$. A rate tuple $(R_{11}, R_{12}, R_{21}, R_{22})$ is said to be achievable if there exist encoders and decoders such that the probability of error can be made arbitrarily small by choosing a sufficiently large T . The closure of all achievable rate pairs is the capacity region and the maximum value of $R_{11} + R_{12} + R_{21} + R_{22}$ across all rate tuples that belong to the capacity region, is the sum-capacity, that we will refer to as simply the capacity, denoted as C , for brevity. Since we are especially interested in linear interference alignment, we will also define C_{linear} as the highest sum-rate possible through vector linear coding schemes (see, e.g., [36]), also known as linear beamforming schemes, over the base field \mathbb{F}_p .

4.2.3 Zero Channels

First, let us deal with trivial cases where some of the channel coefficients are zero.

THEOREM 4.1. *If one or more of the channel coefficients h_{ji} is equal to zero, the capacity is given as follows.*

1. *If $h_{12} = h_{21} = 0$ and $h_{11}, h_{22} \neq 0$, then $C = C_{\text{linear}} = 2$.*
2. *If $h_{11} = h_{22} = 0$ and $h_{12}, h_{21} \neq 0$, then $C = C_{\text{linear}} = 2$.*
3. *If $h_{11} = h_{12} = h_{21} = h_{22} = 0$, then $C = C_{\text{linear}} = 0$.*

4. In all other cases where at least one channel coefficient is zero, $C = C_{linear} = 1$.

Proof: Cases 1, 2, 3 are trivial. The resulting channel for Case 4 is a MAC, BC or Z channel. MAC and BC have capacity 1 by min-cut max-flow theorem, and the proof for the Z channel follows from the corresponding DoF result presented in [28] (Theorem 1, 2) for the wireless setting.

4.2.4 X Channel Normalization

Based on Theorem 4.1, henceforth we will assume that all channel coefficients are non-zero. Without loss of generality, let us normalize the channel coefficients at the sources and destinations as shown in Fig. 4.2. Since these are invertible operations, they do not affect the channel capacity.

The normalized X channel is represented as

$$y_1 = x_1 + x_2 \tag{4.7}$$

$$y_2 = hx_1 + x_2 \tag{4.8}$$

wherein we have reduced the channel parameters to a single channel coefficient h , defined as

$$h = \frac{h_{12}h_{21}}{h_{11}h_{22}} \tag{4.9}$$

4.2.5 Capacity of the Finite Field X Channel

As mentioned in the review of prior work, the multiple input multiple output (MIMO) wireless X channel where each node is equipped with n antennas has $\frac{4n}{3}$ DoF [28, 12]. For almost all channel realizations in the wireless setting, the DoF are achieved through a linear vector space interference alignment scheme. If n is a multiple of 3, no symbol extensions are needed and spatial beamforming is sufficient. For example, if each node is equipped with 3 antennas, then it

suffices to send 1 symbol per message, each along its assigned 3×1 signal vector. The vectors are chosen such that the two undesired symbols at each destination align in the same dimension leaving the remaining 2 dimensions free to resolve the desired signals. If n is not a multiple of 3 then 3 symbol extensions (i.e., coding over 3 channel uses) are needed to create a vector space within which a third of the dimensions are assigned to each message. When translating these insights into the finite field X channel with only scalar inputs and scalar outputs (SISO) we are guided by the main insight presented below.

Insight: MIMO interpretation

The main insight that forms the basis of this work is that *a SISO network over \mathbb{F}_{p^n} is analogous to a $n \times n$ MIMO network, albeit with a special structure imposed on the channel matrix due to finite field arithmetic.*

To appreciate this insight, let us briefly review the fundamentals. The finite field \mathbb{F}_{p^n} can be used to generate an n -dimensional vector space as follows. Each element of \mathbb{F}_{p^n} can be represented in the form

$$z = x_{n-1}s^{n-1} + x_{n-2}s^{n-2} + \dots + x_1s^1 + x_0 \tag{4.10}$$

wherein $z \in \mathbb{F}_{p^n}$, $x_i \in \mathbb{F}_p$.

As an example consider \mathbb{F}_{3^3} which contains 27 elements $\{0, 1, \dots, 26\}$ and each element $a \in \mathbb{F}_{3^3}$ is of the form $3^2a_2+3a_1+a_0$, wherein $a_2, a_1, a_0 \in \mathbb{F}_3$ with values from $\{0, 1, 2\}$. Hence every element can be written in a vector notation with coefficients $[a_2; a_1; a_0]$, e.g., $a = 22$ can be written as $[2; 1; 1]$.

Next, let us see how multiplication with the channel coefficient $h \in \mathbb{F}_{3^3}$ is represented as a multiplication with a 3×3 matrix with elements in \mathbb{F}_3 . Consider the monic irreducible cubic polynomial

$s^3 + 2s + 1$ which is treated as zero in the field. The field itself consists of all polynomials with coefficients in \mathbb{F}_3 , modulo $s^3 + 2s + 1$. Since $s^3 + 2s + 1 = 0$ in \mathbb{F}_{3^3} , it follows that

$$s^3 = -2s - 1 = (3 - 2)s + (3 - 1) = s + 2 \quad (4.11)$$

$$s^4 = s(s^3) = s(s + 2) = s^2 + 2s \quad (4.12)$$

Since $h, x \in \mathbb{F}_{3^3}$ they can be represented as $h = h_2s^2 + h_1s + h_0$, $x = x_2s^2 + x_1s + x_0$ where $h_i, x_i \in \mathbb{F}_3$. The product $y = hx \in \mathbb{F}_{3^3}$ can be written as

$$\begin{aligned} y &= hx \equiv (h_2s^2 + h_1s + h_0)(x_2s^2 + x_1s + x_0) \\ &= s^4(h_2x_2) + s^3(h_2x_1 + h_1x_2) + s^2(h_2x_0 + h_0x_2 + h_1x_1) + s(h_1x_0 + h_0x_1) + (h_0x_0) \\ &= s^2(h_2x_2 + h_2x_0 + h_0x_2 + h_1x_1) + s(2h_2x_2 + h_2x_1 + h_1x_2 + h_1x_0 + h_0x_1) \\ &\quad + (h_0x_0 + 2h_2x_1 + 2h_1x_2) \end{aligned}$$

Equivalently,

$$\mathbf{y} = \mathbf{H}\mathbf{x} = \begin{bmatrix} h_2 + h_0 & h_1 & h_2 \\ 2h_2 + h_1 & h_2 + h_0 & h_1 \\ 2h_1 & 2h_2 & h_0 \end{bmatrix} \begin{bmatrix} x_2 \\ x_1 \\ x_0 \end{bmatrix} \quad (4.13)$$

wherein \mathbf{x}, \mathbf{y} are 3×1 vector with entries from \mathbb{F}_3 and \mathbf{H} is a 3×3 matrix with its 9 entries from \mathbb{F}_3 . Here the equivalence of SISO channel over \mathbb{F}_{3^3} and MIMO channel over \mathbb{F}_3 is established through the 3×3 linear transformation, \mathbf{H} . Note also the structure inherent in the matrix representation \mathbf{H} . While there are 3^9 possible 3×3 matrices over \mathbb{F}_3 , there are only 27 valid \mathbf{H} matrices, because \mathbb{F}_{3^3} has only 27 elements. This leads us to the main challenge that remains.

Table 4.1: Summary — 2-user X channel over finite fields

Finite field	# Symbol extensions	# \mathbb{F}_p Input symbols*	Result
\mathbb{F}_{p^3}	1	1	Capacity = Linear capacity = $\frac{4}{3}$, for all p
\mathbb{F}_{p^n}	3	n	Capacity = Linear capacity = $\frac{4}{3}$, for $p > 2$
\mathbb{F}_{p^2}	3	2	Capacity = Linear capacity = $\frac{4}{3}$, for all p

* — # \mathbb{F}_p Input symbols denotes the number of input symbols from the field \mathbb{F}_p , per message and per extended channel use.

Challenge: Channel Structure

Given the main insight, the challenge that remains is dealing with the structural constraints on the MIMO channels that arise due to finite field arithmetic. Structured channels are also encountered in the wireless setting — channels obtained by symbol extensions have a block diagonal structure [28], asymmetric complex signaling based schemes used for the SISO X channel have a unitary matrix structure [12]. Channel structure can be destructive, e.g., loss of capacity in rank deficient channels. However, channel structure can also be constructive, e.g., diagonal channel matrices enable the CJ scheme in [9], and certain types of rank deficiencies have been shown to facilitate simpler alternatives to interference alignment schemes [32]. On the one hand, the MIMO channels, which arise by viewing \mathbb{F}_{p^n} as an n dimensional vector space over \mathbb{F}_p , have a structure that is neither diagonal nor unitary. On the other hand, diagonal channel matrices, unitary channel matrices, as well as the finite field channel matrices, all have the property that matrix multiplication is commutative, which can be a very useful property for interference alignment schemes. The impact of channel structure in the SISO constant finite field X channel setting is therefore an intriguing question.

Main Result

The capacity result for the finite field X channel is presented in the following theorem.

THEOREM 4.2. *For the fully connected X channel over \mathbb{F}_{p^n} , with $p > 2$, if*

$$h = \frac{h_{12}h_{21}}{h_{11}h_{22}} \notin \mathbb{F}_p \quad (4.14)$$

then

$$C = C_{linear} = \frac{4}{3} \quad (4.15)$$

in units of \mathbb{F}_{p^n} symbols per channel use. If $h \in \mathbb{F}_p$, then $C_{linear} = 1$.

Proof: The information theoretic outer bound of $\frac{4}{3}$ follows immediately from the DoF outer bound for the wireless setting presented in [28] (Theorem 5, 6), a combination of the Z channel bounds, with minor adjustments to account for finite field channels. The linear capacity bound of 1 when $h \in \mathbb{F}_p$ is also straightforward because in this case, regardless of the number of channel extensions, all channel matrices are simply scaled identity matrices. Since the scaling factors are irrelevant for vector spaces, i.e., beamforming schemes, the linear capacity is not changed if we replace all channel gains with unity. But such a channel has only rank 1 (equivalently min-cut value of 1) per channel use, so its sum-rate is bounded by 1, which is therefore also an outer bound for linear capacity on the original channel. Achievability of rate 1 is trivial in a fully connected X channel. So this leaves us only to prove that a sum rate of $\frac{4}{3}$ is achievable through vector linear schemes when $h \notin \mathbb{F}_p$. The achievability scheme is the simplest, i.e., no symbol extensions are required and only scalar linear coding (one stream per message) is sufficient, when n is 3. Proof of achievability involves showing that there exist choices for beamforming vectors such that the desired signals are resolvable from interference at all destinations. Whereas in wireless setting the resolvability of desired signals from interference is guaranteed “almost surely” due to the generic properties of channels drawn from continuous distributions, in the finite field setting it needs an explicit constructive proof. This is the main source of added difficulty in dealing with the finite field counterparts of wireless networks. For ease of exposition, the achievability proof for this case,

i.e., for the X channel over \mathbb{F}_{p^3} is presented first, in Section 4.2.7. The achievability proof over \mathbb{F}_{p^2} , which requires a slightly different approach, is presented in Appendix I. The proofs over \mathbb{F}_{p^3} and \mathbb{F}_{p^2} are *not restricted* to $p > 2$. The achievability proof for the remaining general case, over \mathbb{F}_{p^n} , $p > 2$, is presented in Section 4.2.8. Note that the proof over \mathbb{F}_{p^n} is for $p > 2$ because of the technique used, and we expect the same capacity result to hold for all p . The achievable scheme is summarized in Table 4.1.

Remark 1. The setting where $h \in \mathbb{F}_p$ corresponds to the real constant SISO wireless X channel. Linear DoF collapse in this setting because even with symbol extensions, the channel matrices are simply scaled identity matrices so that the alignment of vector spaces is identical at both destinations, making it impossible to have signals align at one destination where they are undesired and remain resolvable at the other destination where they are desired. Since $h \in \mathbb{F}_p$ is the only exception where the capacity falls short of $4/3$, it is evident from Theorem 4.2 that the capacity results for the 2 user finite field constant X over \mathbb{F}_{p^n} closely mirror the corresponding DoF results for the real MIMO X channel where each user has n antennas. Remarkably, even though the channels in the finite field setting are highly structured, the structural constraints do not impact the capacity result. The significance of channel structure will become transparent when we study the 3 user interference channel later in this paper.

Remark 2. Note that there are $p^n - 1$ possible non-zero values for h , out of which all but $p - 1$ have the capacity value of $\frac{4}{3}$ which is achieved by linear beamforming. The fraction of degenerate fully connected channel instances, for which $C_{\text{linear}} = 1$, is therefore as follows.

$$\frac{(p - 1)}{(p^n - 1)} = \frac{1}{1 + p + p^2 + \dots + p^{n-1}} \quad (4.16)$$

which approaches 0 as $p \rightarrow \infty$. Note the similarity with the constant X channel in the wireless setting for which Cadambe et al. have shown in [12] for the complex case and Motahari et al. have shown in [40] for the real case, that interference alignment scheme achieves $4/3$ DoF for *almost all* channel realizations. Remarkably, in the finite field case the fraction of channels with

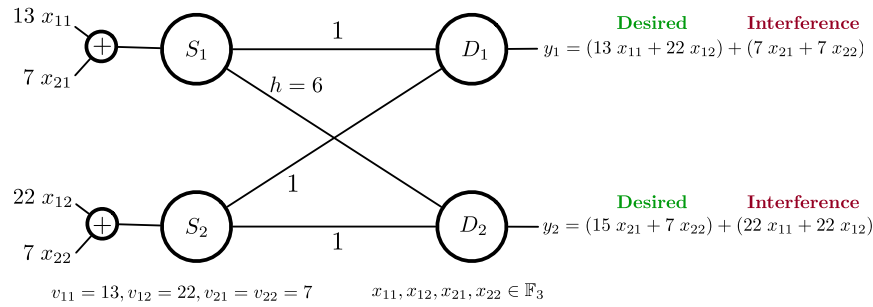

Figure 4.3: An instance of the X channel over \mathbb{F}_{3^3} and its capacity optimal solution represented in scalar notation.

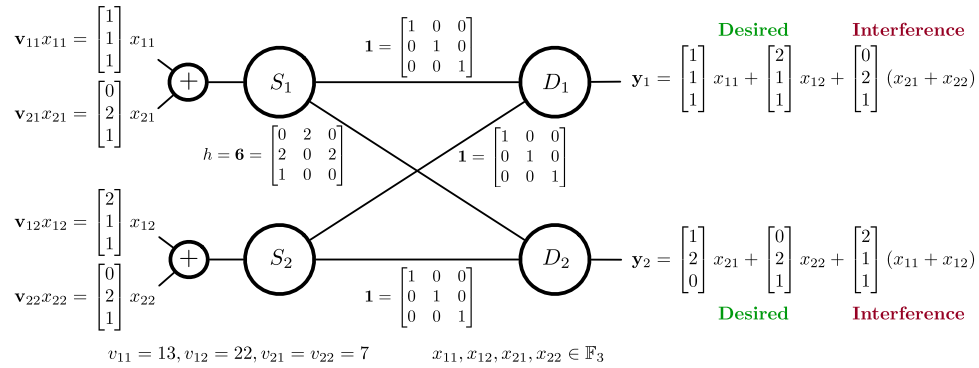

Figure 4.4: The same example and solution as Fig. 4.3, illustrated in vector notation.

linear capacity $4/3$ is non-trivial and still precisely computable. While a tangible connection seems elusive, it is an intriguing thought, whether interpreting p and n in (4.16) as analogous to finite SNR and finite diversity in the wireless setting might lead to finer insights there that are not available directly from the coarse DoF metric.

4.2.6 Achievability over \mathbb{F}_{p^2}

\mathbb{F}_{p^2} can be viewed as a 2-dimensional vector space over subfield \mathbb{F}_p , much like the field of complex numbers can be viewed as a 2-dimensional vector space over reals (\mathbb{R}), which is also the essential idea behind the asymmetric complex signaling scheme used in [12] to achieve $4/3$ DoF for the constant SISO wireless X channel with complex coefficients. We can represent each element of \mathbb{F}_{p^2} as

$$z = x + y\sqrt{c} \quad \text{or} \quad x + ys \tag{4.17}$$

wherein $z \in \mathbb{F}_{p^2}$, $x, y \in \mathbb{F}_p$ and c is a quadratic non-residue (an element that does not have a square root in \mathbb{F}_p) similar to -1 (which does not have a square root over reals) in the field of complex numbers. ($s = \sqrt{c} \equiv j$).

For example, consider \mathbb{F}_{3^2} with prime subfield \mathbb{F}_3 which has $c = -1(\text{mod } 3) = 2$ as the quadratic non-residue, since $\sqrt{2}$ does not exist in \mathbb{F}_3 . Field \mathbb{F}_{3^2} contains 9 elements and every element $a_1s + a_0$ can be written in a vector notation with coefficients $[a_1; a_0]$ wherein $a_1, a_0 \in \mathbb{F}_3 = \{0, 1, 2\}$ and assigned a scalar integer label $\{0, 1, \dots, 8\}$ as $3a_1 + a_0$. For example, the field element labeled $a = 7$ can be represented as $[2; 1]$ in vector notation, and as $2s + 1$ in polynomial notation. Here, product with h can be represented using a 2×2 linear transformation (MIMO equivalent). Let $h = h_1s + h_0$, $x = x_1s + x_0$ and $h_i, x_i \in \mathbb{F}_3$. Then the product $y = hx \in \mathbb{F}_{3^2}$ can be written as

$$y = hx = (h_1s + h_0)(x_1s + x_0) = s^2(h_1x_1) + s(h_1x_0 + h_0x_1) + (h_0x_0) \tag{4.18}$$

and in vector notation as

$$\mathbf{y} = \mathbf{H}\mathbf{x} = \begin{bmatrix} h_0 & 2h_1 \\ h_1 & h_0 \end{bmatrix} \begin{bmatrix} x_1 \\ x_0 \end{bmatrix} \quad (4.19)$$

wherein $\mathbf{x} \in \mathbb{F}_3^{2 \times 1}$ and $\mathbf{H} \in \mathbb{F}_3^{2 \times 2}$. It can be noted that above 2×2 linear transformation is equivalent to complex multiplication and stacking the resulting real and imaginary parts in a 2×1 vector.

Achievability for \mathbb{F}_{p^2}

Proof: Now we prove that sum rate of $\frac{4}{3}$ is achievable (part of Theorem 4.2 proof) for 2-user X-channel over \mathbb{F}_{p^2} . We consider the X channel with 3 symbol extensions, wherein we can represent the channel between source i and destination j as $H_{ji} = h_{ji}I_3$ where I_3 is the 3×3 identity matrix and h_{ji} is the scalar channel coefficient from \mathbb{F}_{p^2} . The inputs x_{ji} are chosen from \mathbb{F}_p and outputs y_j over \mathbb{F}_{p^2} and three channel uses can be seen as a 6 dimensional vector space over \mathbb{F}_p within which 4 desired symbols and 4 interference symbols are present at each destination. In order to achieve capacity, interference should be aligned within 2 dimensions at each destination. Received symbols at the destinations, in vector notation, are given by

$$\mathbf{y}_1 = V_{11}\mathbf{x}_{11} + V_{12}\mathbf{x}_{12} + V_{22}\mathbf{x}_{22} + V_{21}\mathbf{x}_{21} \quad (4.20)$$

$$\mathbf{y}_2 = V_{22}\mathbf{x}_{22} + \bar{\mathbf{H}}V_{21}\mathbf{x}_{21} + \bar{\mathbf{H}}V_{11}\mathbf{x}_{11} + V_{12}\mathbf{x}_{12} \quad (4.21)$$

Here $\mathbf{y}_j \in \mathbb{F}_p^{6 \times 1}$, $V_{ji} \in \mathbb{F}_p^{6 \times 2}$, and $\mathbf{x}_{ji} \in \mathbb{F}_p^{2 \times 1}$ represents the symbols sent by source i for destination j . $\bar{\mathbf{H}} \in \mathbb{F}_p^{6 \times 6}$ is the linear transformation which is equivalent to multiplication by $h \in \mathbb{F}_{p^2}$. Over 3 symbol extensions of the channel, linear transformation for $p > 2$, is given by $\bar{\mathbf{H}} = [h_0I_3 \ c h_1I_3; h_1I_3 \ h_0I_3]$, wherein I_3 is the 3×3 identity matrix, and c is the quadratic non-residue which exists for all $p > 2$. In order to achieve sum rate of $\frac{4}{3}$, interference should be aligned at both

destinations, similar to \mathbb{F}_{p^n} . We choose beamforming vectors as

$$V_{22} = V_{21} = \begin{bmatrix} 1 & 1 & 1 & 0 & 1 & 1 \\ 0 & 0 & 1 & 0 & 1 & 1 \end{bmatrix}^T \quad (4.22)$$

$$V_{11} = \begin{bmatrix} 1 & 1 & 0 & 1 & 0 & 0 \\ 1 & 0 & 0 & 1 & 1 & 1 \end{bmatrix}^T \quad V_{12} = \bar{\mathbf{H}}V_{11} \quad (4.23)$$

At each destination, signal space can be represented using 6×6 matrices, S_1 and S_2 .

$$S_1 = [V_{11} \ V_{12} \ V_{21}] = [V_{11} \ \bar{\mathbf{H}}V_{11} \ V_{21}] \quad (4.24)$$

$$S_2 = [V_{22} \ \bar{\mathbf{H}}V_{21} \ V_{12}] = [V_{21} \ \bar{\mathbf{H}}V_{21} \ \bar{\mathbf{H}}V_{11}] \quad (4.25)$$

Determinant polynomials of matrices S_1 and S_2 are given as: $|S_1| = ch_1^2$ and $|S_2| = h_1^2(ch_1^2 - h_0^2)$. Determinant of matrix S_1 is non-zero since $h_1 \neq 0$ when $h \notin \mathbb{F}_p$, and a non-zero quadratic non-residue exists for all $p > 2$. When considering determinant polynomial of matrix S_2 , since $h_1^2 \neq 0$ ($h \notin \mathbb{F}_p$), $|S_2| = 0$ only if $c = \frac{h_0^2}{h_1^2}$. But this is clearly not possible since the quadratic non-residue, c cannot be a square of any element in \mathbb{F}_p ($\frac{h_0}{h_1} \in \mathbb{F}_p$). Hence, columns of matrices S_1 and S_2 are linearly independent over \mathbb{F}_p , implying that the desired and interference signals do not overlap.

Note that \mathbb{F}_{2^2} is a special case because there is no quadratic non-residue, where the scheme is equivalent to having a 2×2 MIMO channel, but not to asymmetric complex signaling. For \mathbb{F}_{2^2} , we are able to solve numerically using MATLAB by constructing beamforming matrices V_{11} and V_{21} . Thus, when $h \notin \mathbb{F}_p$, we have shown that the desired signals are resolvable, and sum rate of $\frac{4}{3}$ is achievable for channels over \mathbb{F}_{p^2} for all p .

4.2.7 Achievability over \mathbb{F}_{p^3}

Proof: Consider the normalized X channel which can be characterized by single channel coefficient $h = \frac{h_{12}h_{21}}{h_{11}h_{22}}$ from \mathbb{F}_{p^3} . We use superposition coding at the sources, wherein messages from source 1, (W_{11}, W_{21}) are independently encoded into symbols x_{11}, x_{21} , respectively, and added to obtain the transmitted symbol $x_1 = x_{11} + x_{21}$ and messages from source 2, (W_{12}, W_{22}) are similarly encoded as $x_2 = x_{21} + x_{22}$. Symbols x_{ji} are from the subfield \mathbb{F}_p . Field \mathbb{F}_{p^3} can be split into a 3-dimensional space over subfield \mathbb{F}_p so that the output has 3 dimensions (each over \mathbb{F}_p) within which 2 desired symbols and 2 interference symbols are present at each destination. To achieve capacity, the 2 interference symbols should be aligned at each destination such that they occupy only one dimension at that destination while remaining distinguishable at the other destination where they are desired. To this end, we will assign a precoding “vector” $v_{ji} \in \mathbb{F}_{p^3}$ to each symbol x_{ji} . Received symbols at the destinations are given as

$$y_1 = v_{11}x_{11} + v_{12}x_{12} + v_{22}x_{22} + v_{21}x_{21} \quad (4.26)$$

$$y_2 = v_{22}x_{22} + hv_{21}x_{21} + hv_{11}x_{11} + v_{12}x_{12} \quad (4.27)$$

wherein $h, y_j \in \mathbb{F}_{p^3}$. Equivalently, using vector notation,

$$\mathbf{y}_1 = \mathbf{v}_{11}x_{11} + \mathbf{v}_{12}x_{12} + \mathbf{v}_{22}x_{22} + \mathbf{v}_{21}x_{21} \quad (4.28)$$

$$\mathbf{y}_2 = \mathbf{v}_{22}x_{22} + \mathbf{H}\mathbf{v}_{21}x_{21} + \mathbf{H}\mathbf{v}_{11}x_{11} + \mathbf{v}_{12}x_{12} \quad (4.29)$$

wherein $\mathbf{y}_j, \mathbf{v}_{ji} \in \mathbb{F}_p^{3 \times 1}$ are 3×1 vectors with \mathbb{F}_p elements and $\mathbf{H} \in \mathbb{F}_p^{3 \times 3}$ is a structured 3×3 matrix with \mathbb{F}_p elements, representing $h \in \mathbb{F}_{p^3}$. For ease of exposition, an instance of the problem and its solution are illustrated in Fig. 4.3 using scalar notation and again in Fig. 4.4 using vector notation. At each destination, interference can be aligned along one dimension by choosing

$$\mathbf{v}_{22} = \mathbf{v}_{21} \quad \& \quad \mathbf{v}_{12} = \mathbf{H}\mathbf{v}_{11} \quad (4.30)$$

At the destinations, the spaces occupied by the two desired symbols and the aligned interference symbol are represented using matrices S_1 (destination 1) and S_2 (destination 2).

$$S_1 = [v_{11} \ v_{12} \ v_{21}] = [v_{11} \ hv_{11} \ v_{21}] \quad (4.31)$$

$$S_2 = [v_{22} \ hv_{21} \ v_{12}] = [v_{21} \ hv_{21} \ hv_{11}] \quad (4.32)$$

When $h \notin \mathbb{F}_p$, we will now show that we can choose v_{11} and v_{21} such that elements of S_1 and S_2 are linearly independent over \mathbb{F}_p . Set $v_{21} = 1$. Then S_1 and S_2 can be written as

$$S_1 = [v_{11} \ hv_{11} \ 1] \quad \& \quad S_2 = [1 \ h \ hv_{11}] \quad (4.33)$$

Consider S_1 . Note that v_{11} and hv_{11} , are linearly independent over \mathbb{F}_p since $h \notin \mathbb{F}_p$, i.e., \mathbf{H} is not a scaled identity matrix. Hence elements of S_1 are linearly independent if $\frac{1}{v_{11}}$ is not a linear combination (with coefficients from \mathbb{F}_p) of 1 and h . This is guaranteed if

$$v_{11} \notin A \triangleq \left\{ \frac{1}{\alpha + \beta h} : \alpha, \beta \in \mathbb{F}_p, (\alpha, \beta) \neq (0, 0) \right\} \cup \{0\} \quad (4.34)$$

Similarly, consider S_2 . Note that 1 and h are linearly independent over \mathbb{F}_p , since \mathbf{H} is not a scaled identity matrix. Hence, elements of S_2 are linearly independent if v_{11} is not a linear combination of $\frac{1}{h}$ and 1 over \mathbb{F}_p . This is guaranteed if

$$v_{11} \notin B \triangleq \left\{ \alpha + \frac{\beta}{h} : \alpha, \beta \in \mathbb{F}_p, (\alpha, \beta) \neq (0, 0) \right\} \cup \{0\} \quad (4.35)$$

Since $|A| \leq p^2$ and $|B| \leq p^2$, and all p constant polynomials are contained in both A and B , we must have

$$|A \cup B| \leq 2p^2 - p \quad (4.36)$$

Unless $A \cup B$ contains all p^3 elements of \mathbb{F}_{p^3} there is at least one choice of v_{11} that satisfies both (4.34) and (4.35). In other words, the scheme works if

$$p^3 > 2p^2 - p \tag{4.37}$$

which is true for all $p \geq 2$. Thus, we have proved the achievability of rate $\frac{1}{3}$ per message, and a sum-rate of $\frac{4}{3}$, which matches the capacity outer bound. Note that a \mathbb{F}_p symbol represents $\frac{1}{3}$ of a \mathbb{F}_{p^3} symbol and the capacity is measured in \mathbb{F}_{p^3} units because the original channel alphabet is from \mathbb{F}_{p^3} . Also note that the achievability proof applies to $p = 2$ as well.

Similar to splitting a field \mathbb{F}_{p^3} to form a 3-dimensional space in field of order p , other fields of order p^n can be split to a n -dimensional field of order p . However, in order to achieve the optimal capacity of $\frac{4}{3}$, symbol extensions would be required when n is not a multiple of 3. The capacity result for the general case is presented in the next section.

4.2.8 Achievability over \mathbb{F}_{p^n}

Proof: Achievability proof for channels over field \mathbb{F}_{p^2} is presented in Appendix I. Here, we discuss achievability proof for channels over field \mathbb{F}_{p^n} , $n > 3$.

Let us use 3 symbol extensions, so that we operate in a $3n$ dimensional vector space over \mathbb{F}_p . Each message W_{ji} is encoded into n streams represented by the elements of the column vector $\mathbf{x}_{ji} \in \mathbb{F}_p^{n \times 1}$, and the n streams are sent along the n column vectors of the precoding matrix $V_{ji} \in \mathbb{F}_p^{3 \times n}$. Thus, the sum data rate is $\frac{4}{3}$ in units of \mathbb{F}_{p^n} symbols per channel use, and it remains to be shown that the desired symbols are resolvable from interference. Over each extended channel use, the

received signals, $\mathbf{y}_1, \mathbf{y}_2 \in \mathbb{F}_p^{3 \times 1}$ at 2 destinations are expressed as:

$$\mathbf{y}_1 = V_{11}\mathbf{x}_{11} + V_{12}\mathbf{x}_{12} + V_{22}\mathbf{x}_{22} + V_{21}\mathbf{x}_{21} \quad (4.38)$$

$$\mathbf{y}_2 = V_{22}\mathbf{x}_{22} + hV_{21}\mathbf{x}_{21} + hV_{11}\mathbf{x}_{11} + V_{12}\mathbf{x}_{12} \quad (4.39)$$

Note that similar to \mathbb{F}_p^3 , above relations can also be represented using vector notation. At each destination, interference can be aligned along n dimensions by choosing

$$V_{22} = V_{21} \quad \& \quad V_{12} = hV_{11} \quad (4.40)$$

At each destination, $2n$ desired symbols and n aligned interference symbols are represented using matrices $S_1 \in \mathbb{F}_p^{3 \times 3n}$ (for destination 1) and $S_2 \in \mathbb{F}_p^{3 \times 3n}$ (for destination 2).

$$S_1 = [V_{11} \ V_{12} \ V_{21}] = [V_{11} \ hV_{11} \ V_{21}] \quad (4.41)$$

$$S_2 = [V_{22} \ hV_{21} \ V_{12}] = [V_{21} \ hV_{21} \ hV_{11}] \quad (4.42)$$

We will now show that when $h \notin \mathbb{F}_p$, we can choose V_{11} and V_{21} such that the columns of S_1 and S_2 are linearly independent over \mathbb{F}_p . Let us denote V_{21} as just V and choose $V_{11} = gV_{21} = gV$ with a non-zero $g \in \mathbb{F}_p$ and $V \in \mathbb{F}_p^{3 \times n}$. Then S_1 and S_2 can be written as

$$S_1 = [gV \ hgV \ V] \quad (4.43)$$

$$S_2 = [V \ hV \ hgV] \quad (4.44)$$

wherein beamforming matrix V has n columns, denoted as $\mathbf{v}_1, \dots, \mathbf{v}_n \in \mathbb{F}_p^{3 \times 1}$. In Fig. 4.5, we illustrate the recursive proof described hereafter.

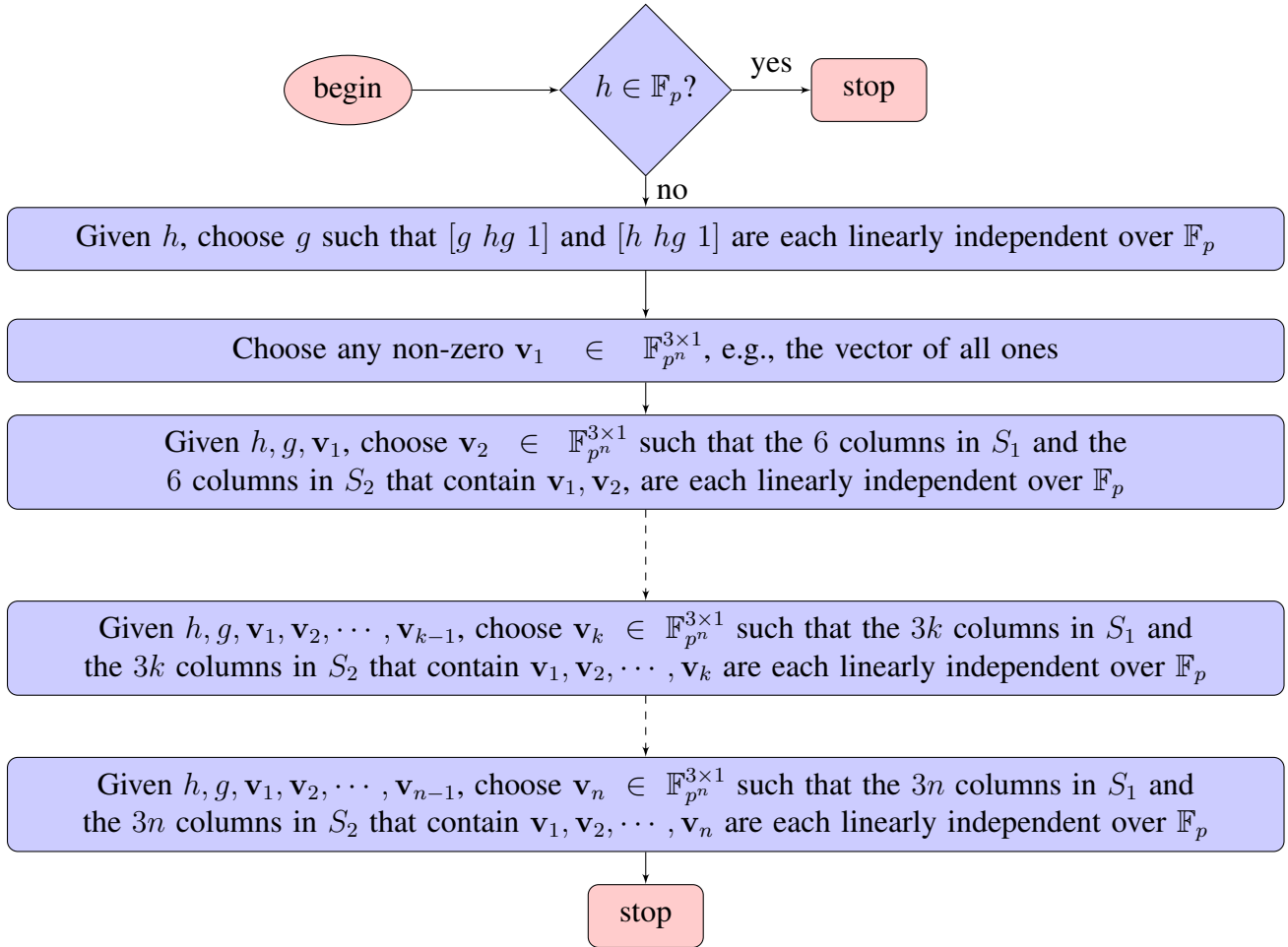

Figure 4.5: Algorithm for the construction of precoding vectors.

Choose \mathbf{v}_1 as the all-ones vector. We first consider columns containing \mathbf{v}_1 . There are three such columns, and they need to be linearly independent over \mathbb{F}_p , in both S_1 and S_2 .

$$\text{From } S_1 : [g\mathbf{v}_1 \quad hg\mathbf{v}_1 \quad \mathbf{v}_1] \quad (4.45)$$

$$\text{From } S_2 : [\mathbf{v}_1 \quad h\mathbf{v}_1 \quad hg\mathbf{v}_1] \quad (4.46)$$

Consider columns of S_1 . Note that $g\mathbf{v}_1$ and $hg\mathbf{v}_1$ are linearly independent over \mathbb{F}_p , since $h \notin \mathbb{F}_p$, i.e., h is not a constant polynomial, and $g, \mathbf{v}_1 \neq 0$. Hence, elements of S_1 are linearly independent over \mathbb{F}_p if $\frac{1}{g}$ is not a linear combination of 1 and h over \mathbb{F}_p . Similarly, elements of S_2 are linearly independent over \mathbb{F}_p if g is not a linear combination of 1 and $\frac{1}{h}$ over \mathbb{F}_p . These are guaranteed if

$$g \notin A \quad \& \quad g \notin B \quad (4.47)$$

wherein A, B are defined as in 4.34 and 4.35. Since $|A| \leq p^2, |B| \leq p^2$ and A and B both contain all p elements of \mathbb{F}_p , we must have $|A \cup B| \leq 2p^2 - p$. Therefore, a choice of g that satisfies both conditions of (4.47) is guaranteed to exist if $p^n > 2p^2 - p$ which is true $\forall n \geq 3$.

If $\mathbf{v}_k \neq 0$, the same choice of g ensures that the following columns from S_1 and S_2 are linearly independent over $\mathbb{F}_p, \forall k \in \{1, \dots, n\}$.

$$\text{From } S_1 : [g\mathbf{v}_k \quad hg\mathbf{v}_k \quad \mathbf{v}_k] \quad (4.48)$$

$$\text{From } S_2 : [\mathbf{v}_k \quad h\mathbf{v}_k \quad hg\mathbf{v}_k] \quad (4.49)$$

We now present the recursive proof for linear independence over \mathbb{F}_p of desired and interference symbols at destinations. At iteration k , column vector \mathbf{v}_{k+1} will be chosen based on previously chosen columns $\mathbf{v}_1, \dots, \mathbf{v}_k$ and g . We already chose \mathbf{v}_1 to be the vector of ones. So now \mathbf{v}_2 will

be chosen such that following columns are linearly independent over \mathbb{F}_p in S_1 and S_2 :

$$\text{From } S_1 : [g\mathbf{v}_1 \quad hg\mathbf{v}_1 \quad \mathbf{v}_1 \quad g\mathbf{v}_2 \quad hg\mathbf{v}_2 \quad \mathbf{v}_2] \quad (4.50)$$

$$\text{From } S_2 : [h\mathbf{v}_1 \quad hg\mathbf{v}_1 \quad \mathbf{v}_1 \quad h\mathbf{v}_2 \quad hg\mathbf{v}_2 \quad \mathbf{v}_2] \quad (4.51)$$

Linear independence over \mathbb{F}_p for (4.50) and (4.51) is guaranteed, respectively, if

$$\mathbf{v}_2 \notin A \triangleq \left\{ \left(\frac{\alpha_1 g + \alpha_2 hg + \alpha_3}{\alpha_4 g + \alpha_5 hg + \alpha_6} \right) \mathbf{v}_1 : \alpha_1, \dots, \alpha_6 \in \mathbb{F}_p, (\alpha_4, \alpha_5, \alpha_6) \neq (0, 0, 0) \right\} \quad (4.52)$$

$$\mathbf{v}_2 \notin B \triangleq \left\{ \left(\frac{\beta_1 h + \beta_2 hg + \beta_3}{\beta_4 h + \beta_5 hg + \beta_6} \right) \mathbf{v}_1 : \beta_1, \dots, \beta_6 \in \mathbb{F}_p, (\beta_4, \beta_5, \beta_6) \neq (0, 0, 0) \right\} \quad (4.53)$$

Now we note that

$$A \cap B \supseteq \left\{ \left(\frac{\beta_2 hg + \beta_3}{\beta_5 hg + \beta_6} \right) \mathbf{v}_1 : \beta_2, \beta_3, \beta_5, \beta_6 \in \mathbb{F}_p, (\beta_5, \beta_6) \neq (0, 0) \right\} \quad (4.54)$$

$$|A| \leq \frac{(p^3 - 1)p^3}{p - 1} = p^5 + p^4 + p^3 \quad (4.55)$$

$$|B| - |A \cap B| \leq \frac{(p^3 - 1)p^3}{p - 1} - \frac{(p^2 - 1)p^2}{p - 1} = p^5 + p^4 - p^2 \quad (4.56)$$

$$|A \cup B| = |A| + |B| - |A \cap B| \leq 2p^5 + 2p^4 + p^3 - p^2 \quad (4.57)$$

Since there are p^{3n} possible choices for \mathbf{v}_2 , there must exist at least one choice that satisfies both (4.52) and (4.53) if

$$p^{3n} > 2p^5 + 2p^4 + p^3 - p^2 \quad (4.58)$$

which is true for all $p > 2$. Similarly this recursion is carried out for choosing vectors $\mathbf{v}_3, \dots, \mathbf{v}_{n-1}$.

We will now describe the last stage of recursion, i.e., choosing vector \mathbf{v}_n for given $h, g, \mathbf{v}_1, \dots, \mathbf{v}_{n-1}$.

We want to design \mathbf{v}_n such that all $3n$ columns are linearly independent over \mathbb{F}_p in S_1 and S_2 :

$$S_1 : [g\mathbf{v}_1 \ hg\mathbf{v}_1 \ \mathbf{v}_1 \ g\mathbf{v}_2 \ hg\mathbf{v}_2 \ \mathbf{v}_2 \ \dots \ g\mathbf{v}_n \ hg\mathbf{v}_n \ \mathbf{v}_n] \quad (4.59)$$

$$S_2 : [h\mathbf{v}_1 \ hg\mathbf{v}_1 \ \mathbf{v}_1 \ h\mathbf{v}_2 \ hg\mathbf{v}_2 \ \mathbf{v}_2 \ \dots \ h\mathbf{v}_n \ hg\mathbf{v}_n \ \mathbf{v}_n] \quad (4.60)$$

The linear independence over \mathbb{F}_p is guaranteed if

$$\mathbf{v}_n \notin A \triangleq \left\{ \sum_{l=1}^{n-1} \left(\frac{\alpha_{3l-2}g + \alpha_{3l-1}hg + \alpha_{3l}}{\alpha_{3n-2}g + \alpha_{3n-1}hg + \alpha_{3n}} \right) \mathbf{v}_l : \alpha_1, \dots, \alpha_{3n} \in \mathbb{F}_p, \right. \\ \left. (\alpha_{3n-2}, \alpha_{3n-1}, \alpha_{3n}) \neq (0, 0, 0) \right\} \quad (4.61)$$

$$\mathbf{v}_n \notin B \triangleq \left\{ \sum_{l=1}^{n-1} \left(\frac{\beta_{3l-2}h + \beta_{3l-1}hg + \beta_{3l}}{\beta_{3n-2}h + \beta_{3n-1}hg + \beta_{3n}} \right) \mathbf{v}_l : \beta_1, \dots, \beta_{3n} \in \mathbb{F}_p, \right. \\ \left. (\beta_{3n-2}, \beta_{3n-1}, \beta_{3n}) \neq (0, 0, 0) \right\} \quad (4.62)$$

$$\Rightarrow A \cap B \supseteq \left\{ \sum_{l=1}^{n-1} \left(\frac{\beta_{3l-1}hg + \beta_{3l}}{\beta_{3n-1}hg + \beta_{3n}} \right) \mathbf{v}_l : \beta_1, \dots, \beta_{3n} \in \mathbb{F}_p, (\beta_{3n-1}, \beta_{3n}) \neq (0, 0) \right\} \quad (4.63)$$

Next we bound the cardinalities as follows.

$$|A| \leq \frac{(p^3 - 1)p^{3n-3}}{p - 1} = p^{3n-1} + p^{3n-2} + p^{3n-3} \quad (4.64)$$

$$|B| - |A \cap B| \leq \frac{(p^3 - 1)p^{3n-3}}{p - 1} - \frac{(p^2 - 1)p^{2n-2}}{p - 1} \\ = p^{3n-1} + p^{3n-2} + p^{3n-3} - p^{2n-1} - p^{2n-2} \quad (4.65)$$

$$|A \cup B| = |A| + |B| - |A \cap B| \leq 2p^{3n-1} + 2p^{3n-2} + 2p^{3n-3} - p^{2n-1} - p^{2n-2} \quad (4.66)$$

Since there are p^{3n} possible choices for \mathbf{v}_n , there must exist at least one choice that satisfies both (4.61) and (4.62) if

$$p^{3n} > 2p^{3n-1}\left(1 + \frac{1}{p} + \frac{1}{p^2}\right) - p^{2n-1} - p^{2n-2} \quad (4.67)$$

which is easily shown to be true for all $p \geq 3$ as follows. If $p \geq 3$ then the RHS is bounded above by $2p^{3n-1}\left(1 + \frac{1}{3} + \frac{1}{9}\right) = \frac{26}{9}p^{3n-1}$ whereas the LHS is bounded below by $3p^{3n-1}$.

4.3 Interference Channel

As noted previously, the impact of channel structure due to finite field operations in \mathbb{F}_{p^n} is not evident in the capacity of the X channel as characterized in Theorem 4.2, because the capacity results for the \mathbb{F}_{p^n} channels mimic the DoF results for the generic $\mathbb{R}^{n \times n}$ real MIMO X channels in the wireless setting. In this section we will extend our study beyond the X channel, to the 3 user interference channel, where the distinction between a generic $\mathbb{R}^{n \times n}$ MIMO setting and the $\mathbb{F}_p^{n \times n}$ MIMO representations of the finite field \mathbb{F}_{p^n} becomes evident. In particular, we will study the linear sum-capacity, C_{linear} , of a finite field 3-user interference channel with 3 source nodes, 3 destination nodes and 3 independent messages as illustrated in Fig. 4.6.

4.3.1 Prior Work

The K user interference channel, with $K > 2$, has been extensively studied in recent years. Cadambe and Jafar showed in [9] that the K -user fully connected interference channel with M antennas at each node has $\frac{MK}{2}$ sum-DoF over a time-varying or frequency-selective channel, based on the CJ scheme. The DoF value of the 3 user constant complex MIMO interference channel with $M > 1$ antennas at each node was also shown by Cadambe and Jafar, to be $\frac{3M}{2}$ using an eigenvec-

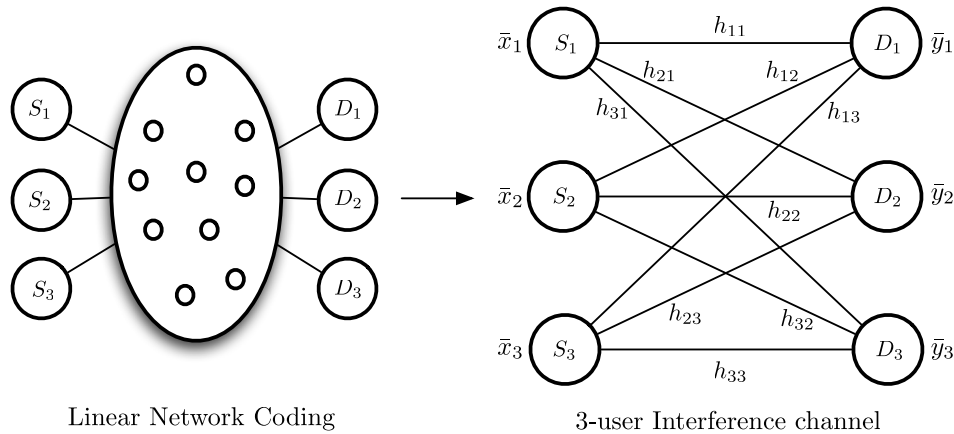

Figure 4.6: Wired network modeled as 3-user interference channel

tor solution. The DoF of asymmetric MIMO settings were characterized in [21, 18, 55, 58] and the linear capacity of generic MIMO interference channels without symbol extensions was studied in [19, 60, 7, 45, 20, 46, 55, 6].

For the complex constant 3 user SISO interference channel, Cadambe et al. showed in [12] that the linear DoF value is $\frac{6}{5}$ using asymmetric complex signaling scheme which precodes the real and imaginary parts of the signal separately. The constant complex SISO channel setting can be interpreted as having diversity 2. Bresler and Tse characterized the DoF of the 3 user time-varying/frequency-selective interference channel as a function of the channel diversity, L , in [8]. While DoF of $\frac{3}{2}$ can be achieved over channel with infinite diversity through the CJ scheme, Bresler and Tse showed that the linear DoF of the 3-user interference channel with finite channel diversity L , is $\frac{3D}{2D+1}$ where $D = 2L - \lfloor L/2 \rfloor - 1$ is known as the alignment depth. Channel diversity, L , was shown to limit the extent to which interference signals can be aligned while maintaining the resolvability of the desired signals from interference. With finite diversity, non-linear schemes are needed to achieve the optimal DoF. Non-linear schemes, which include ideas from diophantine approximations, rational dimensions, Renyi information dimensions, and non-trivial combinatorial outer bound arguments, are not well understood even in the wireless setting. While these are

promising directions for the finite field setting (especially the combinatorial aspects), non-linear schemes are beyond the scope of this paper.

In the context of network coding, the 3 unicast problem which is the counterpart of the 3 user interference channel, was studied in [16, 43, 38] by Das et al., Ramakrishnan et al., and Meng et al., who introduced the Precoding-Based Network Alignment (PBNA) framework and found conditions under which half the source-destination min-cut was achievable for each user. The results were extended to networks with delay in [3]. These works require time-varying channel coefficients due to a direct translation from the CJ scheme originally designed for the time-varying interference channel. However, in this work we will focus only on the constant channel setting over \mathbb{F}_{p^n} , viewed as a constant $\mathbb{F}_p^{n \times n}$ MIMO setting. In particular, we wish to understand the significance of the channel structure.

4.3.2 Finite Field Interference Channel Model

Consider the finite field 3-user interference channel

$$\bar{y}_1(t) = h_{11}\bar{x}_1(t) + h_{12}\bar{x}_2(t) + h_{13}\bar{x}_3(t) \quad (4.68)$$

$$\bar{y}_2(t) = h_{21}\bar{x}_1(t) + h_{22}\bar{x}_2(t) + h_{23}\bar{x}_3(t) \quad (4.69)$$

$$\bar{y}_3(t) = h_{31}\bar{x}_1(t) + h_{32}\bar{x}_2(t) + h_{33}\bar{x}_3(t) \quad (4.70)$$

where, over the t^{th} channel use, $\bar{x}_i(t)$ is the symbol sent by source i , h_{ji} represents channel coefficient between source i and destination j and \bar{y}_j represents the received symbol at destination j . All symbols $\bar{x}_i(t)$, h_{ji} , $\bar{y}_j(t)$ and addition and multiplication operations are in a finite field \mathbb{F}_{p^n} . The channel coefficients h_{ji} are constant across t channel uses and assumed to be perfectly known at all sources and destinations. There are three independent messages, with W_i denoting the message that originates at source i and is intended for destination i .

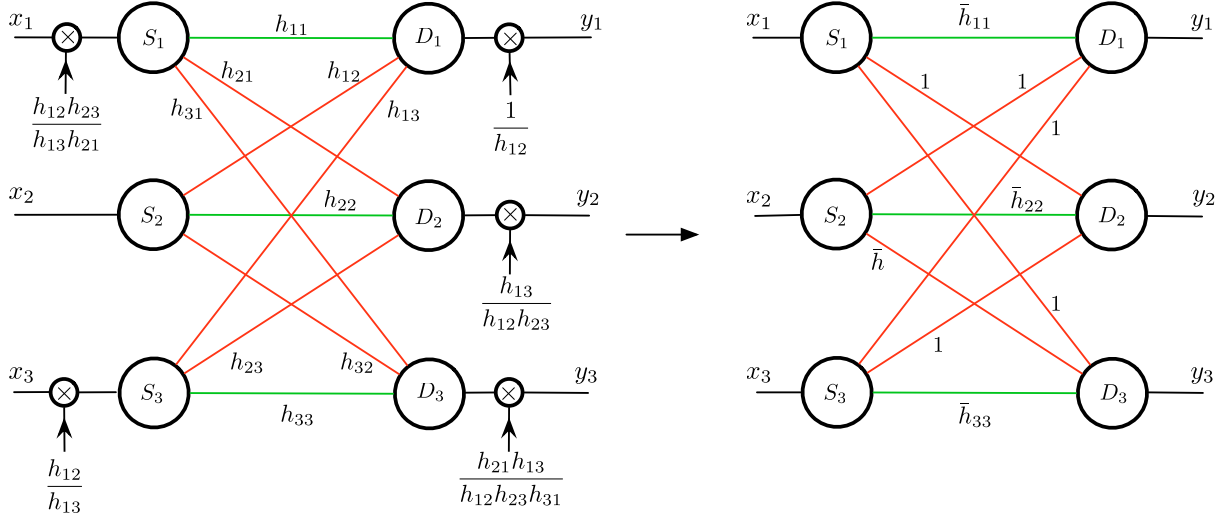

Figure 4.7: Normalization in 3-user Interference Channel

A coding scheme over T channel uses, that assigns to each message W_i a rate R_i , measured in units of \mathbb{F}_{p^n} symbols per channel use, corresponds to a encoding function at each source i that maps the messages originating at that source into a sequence of T transmitted symbols, and a decoding function at each destination that maps the sequence of T received symbols into decoded messages \hat{W}_i .

$$\text{Encoder 1: } (W_1) \rightarrow \bar{x}_1(1)\bar{x}_1(2) \cdots \bar{x}_1(T) \quad (4.71)$$

$$\text{Encoder 2: } (W_2) \rightarrow \bar{x}_2(1)\bar{x}_2(2) \cdots \bar{x}_2(T) \quad (4.72)$$

$$\text{Encoder 3: } (W_3) \rightarrow \bar{x}_3(1)\bar{x}_3(2) \cdots \bar{x}_3(T) \quad (4.73)$$

$$\text{Decoder 1: } \bar{y}_1(1)\bar{y}_1(2) \cdots \bar{y}_1(T) \rightarrow (\hat{W}_1) \quad (4.74)$$

$$\text{Decoder 2: } \bar{y}_2(1)\bar{y}_2(2) \cdots \bar{y}_2(T) \rightarrow (\hat{W}_2) \quad (4.75)$$

$$\text{Decoder 3: } \bar{y}_3(1)\bar{y}_3(2) \cdots \bar{y}_3(T) \rightarrow (\hat{W}_3) \quad (4.76)$$

Each message W_i is uniformly distributed over $\{1, 2, \dots, \lceil p^{nTR_i} \rceil\}$, $\forall i \in \{1, 2, 3\}$. An error occurs if $(\hat{W}_1, \hat{W}_2, \hat{W}_3) \neq (W_1, W_2, W_3)$. A rate tuple (R_1, R_2, R_3) is said to be achievable if there exist encoders and decoders such that the probability of error can be made arbitrarily small by

choosing a sufficiently large T . The closure of all achievable rate pairs is the capacity region and the maximum value of $R_1 + R_2 + R_3$ across all rate tuples that belong to the capacity region, is the sum-capacity, C . Since we are interested in linear interference alignment, we will again define *linear capacity*, C_{linear} , as the highest sum-rate possible through vector linear coding schemes over the base field \mathbb{F}_p .

4.3.3 Interference Channel Normalization

As noted in the X channel, since the main insights come from the fully connected setting, we will assume that all channel coefficients are non-zero. Channel settings where some of the channels are zero are dealt with separately in the Appendix II. Without loss of generality, let us normalize the channel coefficients at the sources and destinations shown in Fig. 4.7. Since these are invertible operations, they do not affect the channel capacity.

The normalized 3-user interference channel can be represented as

$$y_1 = \bar{h}_{11}x_1 + x_2 + x_3 \quad (4.77)$$

$$y_2 = x_1 + \bar{h}_{22}x_2 + x_3 \quad (4.78)$$

$$y_3 = x_1 + \bar{h}x_2 + \bar{h}_{33}x_3 \quad (4.79)$$

wherein we have reduced channel parameters to four channel coefficients $\bar{h}_{11}, \bar{h}_{22}, \bar{h}_{33}, \bar{h}$, defined as

$$\bar{h}_{11} = \frac{h_{11}h_{23}}{h_{13}h_{21}}, \quad \bar{h}_{22} = \frac{h_{22}h_{13}}{h_{23}h_{12}}, \quad \bar{h}_{33} = \frac{h_{33}h_{21}}{h_{31}h_{23}}, \quad \bar{h} = \frac{h_{13}h_{21}h_{32}}{h_{12}h_{23}h_{31}} \quad (4.80)$$

4.3.4 Linear-scheme Capacity of the Finite Field Interference Channel

In the study of the X channel, we noted how scalar channels over \mathbb{F}_{p^n} can be viewed as $n \times n$ MIMO channels over \mathbb{F}_p . Let us see if the same insight can be carried over to the 3 user interference channel. For the 3 user MIMO interference channel, an eigenvector based interference alignment solution that achieves the optimal DoF value, is introduced by Cadambe and Jafar in [9]. Let us see if the same solution applies in the finite field setting as well. As we will show, while the eigenvector solution holds in the wireless case for almost all channel realizations, because of channel structure in the finite field case, the solution holds only in certain ‘degenerate’ settings, that are increasingly rare as the base field size increases, so that in the limit of infinite p , the eigenvector solution does not hold, almost surely.

THEOREM 4.3. *Fully connected 3-user interference channel over \mathbb{F}_{p^n} has capacity $C = C_{linear} = \frac{3}{2}$ for all $p > 3$, if*

$$\bar{h}_{11} \notin \mathbb{F}_p, \quad \bar{h}_{22} \notin \mathbb{F}_p, \quad \bar{h}_{33} \notin \mathbb{F}_p, \quad \bar{h} \in \mathbb{F}_p \quad (4.81)$$

Proof: The outer bound of $\frac{3}{2}$ extends from [9] with only minor adjustments to account for operating over finite fields. Achievable scheme is presented here. Let us denote the $n \times n$ linear transformation corresponding to product by \bar{h} as H . i.e., $\bar{h} \in \mathbb{F}_{p^n}$ and $H \in \mathbb{F}_p^{n \times n}$. The achievable scheme involves beamforming vectors $\bar{V}_1, \bar{V}_2, \bar{V}_3 \in \mathbb{F}_p^{n \times 1}$ at the 3 sources such that interference is aligned at all destinations. Note that we need eigenvectors of H (and also the eigenvalues) to be in \mathbb{F}_p . This implies that the eigen vector solution of [9] can be used only when $\bar{h} \in \mathbb{F}_p$ to achieve linear-scheme capacity of $\frac{3}{2}$. Note that this is analogous to the asymmetric complex signaling setting studied in [12] where because the scalar complex channels become rotation matrices over reals, they do not have eigenvectors over reals unless the rotation is identity. Since $\bar{h} \in \mathbb{F}_p$, H is a scaled identity matrix, and every vector is an eigenvector of this matrix. Let us choose the same beamforming matrices at the 3 sources, $\bar{V} = \bar{V}_1 = \bar{V}_2 = \bar{V}_3$. This ensures that interference

is aligned at all destinations for the normalized 3-user interference channel. At destination 3, interference from source 2 ($\bar{h}\bar{V}$) spans the same space as interference from source 1 (\bar{V}), since $\bar{h} \in \mathbb{F}_p$. Having aligned interference at the destinations, we now discuss construction of the beamforming matrix, such that desired and interference symbols are linearly independent at all destinations. Above theorem is stated for all $p > 3$, owing to the proof technique used, and we expect the result to hold for $p = 2$.

Achievability:

In the achievability proof, depending on whether n is odd or even, number of symbol extensions m and input symbols per channel use t take different values.

When n is odd ($n = 2l + 1$), $m = 2$ symbol extensions are used, we choose $\bar{V} \in \mathbb{F}_{p^n}^{2 \times t}$ and send $t = n$ input symbols per channel use ($x_1, \dots, x_n \in \mathbb{F}_p$) from each source. Interference will be aligned at all destinations in an n dimensional space.

When n is even ($n = 2l$), symbol extensions are not required ($m = 1$), we choose $\bar{V} \in \mathbb{F}_{p^n}^{1 \times t}$ and send $t = l$ input symbols per channel use ($x_1, \dots, x_l \in \mathbb{F}_p$) from each source. Since $\bar{V} = \bar{V}_1 = \bar{V}_2 = \bar{V}_3$, it can be noted that interference will be aligned at all destinations in l dimensional space.

Let us denote the t columns of \bar{V} as $\mathbf{v}_1, \mathbf{v}_2, \dots, \mathbf{v}_t$. Then, the signal space at Destination k can be represented as

$$S_k = [\bar{h}_{kk}\bar{V} \ \bar{V}] = [\bar{h}_{kk}\mathbf{v}_1, \bar{h}_{kk}\mathbf{v}_2, \dots, \bar{h}_{kk}\mathbf{v}_t, \mathbf{v}_1, \mathbf{v}_2, \dots, \mathbf{v}_t] \quad (4.82)$$

We now describe how to choose columns of \bar{V} such that desired and interference symbols are linearly independent at all destinations. Let us choose \mathbf{v}_1 to be vector of ones. This implies that the 2 columns $[\bar{h}_{kk}\mathbf{v}_1 \ \mathbf{v}_1]$ in S_k are linearly independent over \mathbb{F}_p since $\bar{h}_{kk} \notin \mathbb{F}_p, k \in \{1, 2, 3\}$. Now

let us construct \mathbf{v}_2 such that 4 columns of S_k are linearly independent over \mathbb{F}_p for $k \in \{1, 2, 3\}$.

$$\text{From } S_k, \mathbf{v}_2 \notin A_k \triangleq \left\{ \frac{(\alpha_1 \bar{h}_{kk} + \alpha_2) \mathbf{v}_1}{\beta_1 \bar{h}_{kk} + \beta_2} : \alpha_1, \alpha_2, \beta_1, \beta_2 \in \mathbb{F}_p, (\beta_1, \beta_2) \neq (0, 0) \right\} \quad (4.83)$$

Now we note that

$$|A_k| \leq \frac{(p^2 - 1)p^2}{p - 1} = p^3 + p^2, \quad k \in \{1, 2, 3\} \quad (4.84)$$

$$|A_1 \cup A_2 \cup A_3| \leq 3(p^3 + p^2) \quad (4.85)$$

There are p^{mn} choices for \mathbf{v}_2 , and since $p^{mn} > 3(p^3 + p^2)$ for all $p > 3$, there exist choices for \mathbf{v}_2 such that all 3 conditions of (4.83) hold. Choosing \mathbf{v}_2 from those, we note that 4 columns of S_1, S_2, S_3 are linearly independent over \mathbb{F}_p . We proceed recursively in a similar manner, for choosing columns $\mathbf{v}_3, \mathbf{v}_4, \dots, \mathbf{v}_{t-1}$ such that $6, 8, \dots, 2(t-1)$ columns are linearly independent over \mathbb{F}_p respectively, in all $S_k, k \in \{1, 2, 3\}$. Now consider the last iteration wherein column \mathbf{v}_t is chosen such that all $2t$ columns are linearly independent over \mathbb{F}_p in all $S_k, k \in \{1, 2, 3\}$, given that $2t - 2$ columns are already linearly independent with appropriate choices of $\mathbf{v}_1, \mathbf{v}_2, \dots, \mathbf{v}_{t-1}$.

$$\text{From } S_k, \mathbf{v}_t \notin A_k \triangleq \left\{ \frac{1}{\beta_1 \bar{h}_{kk} + \beta_2} \left((\alpha_1 \bar{h}_{kk} + \alpha_2) \mathbf{v}_1 + (\alpha_3 \bar{h}_{kk} + \alpha_4) \mathbf{v}_2 + \dots + (\alpha_{2t-3} \bar{h}_{kk} + \alpha_{2t-2}) \mathbf{v}_{t-1} \right) : \alpha_i, \beta_1, \beta_2 \in \mathbb{F}_p, i \in \{1, \dots, 2t-2\}, (\beta_1, \beta_2) \neq (0, 0) \right\} \quad (4.86)$$

Now we note that

$$|A_k| \leq \frac{(p^2 - 1)p^{2t-2}}{p - 1} = p^{2t-1} + p^{2t-2}, k \in \{1, 2, 3\} \quad (4.87)$$

$$|A_1 \cup A_2 \cup A_3| \leq 3(p^{2t-1} + p^{2t-2}) \quad (4.88)$$

There are p^{mn} choices for \mathbf{v}_t , and since $p^{mn} > 3(p^{2t-1} + p^{2t-2})$ for all $p > 3$, there exist choices for \mathbf{v}_t such that all 3 conditions of (4.86) hold. Choosing \mathbf{v}_t from those, we note that all $2t$ columns of S_1, S_2, S_3 are linearly independent over \mathbb{F}_p . Hence, desired and interference symbols are linearly

independent at all destinations. Thus, sum rate of $\frac{3}{2}$ is achieved over \mathbb{F}_{p^n} for all n with $p > 3$, if $\bar{h}_{kk} \notin \mathbb{F}_p, k \in \{1, 2, 3\}$ and $\bar{h} \in \mathbb{F}_p$.

Remark 3. The fraction of channel realizations for which the conditions $\bar{h}_{kk} \notin \mathbb{F}_p, k \in \{1, 2, 3\}$ and $\bar{h} \in \mathbb{F}_p$ hold, is given by

$$\frac{p}{p^n} \times \left(\frac{p^n - p}{p^n}\right)^3 \quad (4.89)$$

which goes to 0 as $p \rightarrow \infty$.

Remark 4. The implications of the structure of the channel become evident now. While we have $n \times n$ MIMO channels, they behave like channels with diversity n , e.g, like diagonal channels, where also the eigenvector solution does not work except over a measure 0 set. To strengthen this insight, we explore the 3-user interference channel further.

Insight: Channel Diversity

As noted for X networks earlier, the finite field \mathbb{F}_{p^n} is analogous to a $n \times n$ MIMO network with special channel structure. The main insight that arises out of exploring the 3-user interference channel is that n is analogous to channel diversity. This is similar to saying that a scalar channel over \mathbb{F}_{p^n} is analogous to n parallel channels over \mathbb{F}_p . In the remainder of this work, we will focus only on linear capacity C_{linear} and reinforce the parallels between n and channel diversity.

Main Result

It is known from [8] that the 3-user interference channel over \mathbb{F}_{p^n} has channel diversity n , and so has linear capacity of $\frac{3D}{2D+1}$ when using linear beam forming schemes with alignment depth $D = 2n - \lfloor n/2 \rfloor - 1$. The alignment depth, i.e., the length of the longest chain of one-to-one alignments, which is a function of channel diversity, is the primary limiting factor impacting both

Table 4.2: Summary — 3-user Interference channel over finite fields

Finite field	# Symbol extensions	# \mathbb{F}_p Input symbols at the 3 sources*	Result
\mathbb{F}_{p^3}	1	2, 1, 1	Linear capacity = $\frac{4}{3}$, for all p
\mathbb{F}_{p^n} , odd $n = 2l + 1$	1	$l + 1, l, l$	Linear capacity = $\frac{3l+1}{2l+1}$, for all p
\mathbb{F}_{p^2}	5	4, 4, 4	Linear capacity = $\frac{6}{5}$, for all p

* — # \mathbb{F}_p Input symbols at the 3 sources denotes the number of input symbols from the field \mathbb{F}_p , sent from the 3 sources per extended channel use.

achievability and converse arguments. The achievable scheme is essentially the asymptotic interference alignment scheme of [9]. Similar to the 2-user X channel, proof of achievability involves showing that there exist choices for beamforming vectors such that the desired signals are resolvable from interference at all destinations. Resolvability of the desired signals from interference does not follow like in wireless channels wherein linear independence is shown using generic properties of the channels, and so, explicit constructive proofs are needed for finite field channels. Outer bounds for linear schemes come from the argument that the alignment depth cannot be more than D , and suppose it were, then desired signal would lie in span of the interference signal at the destinations. The result translates into the finite field setting as follows. We will focus mainly on the case where n is odd (the cases where n is even follow similarly and will be touched upon briefly).

THEOREM 4.4. *The 3-user interference channel over \mathbb{F}_{p^n} with odd $n = 2l + 1$ has linear capacity*

$$C_{\text{linear}} = \frac{3l+1}{2l+1} \text{ if}$$

$$\bar{h}_{11} \notin A \triangleq \left\{ \frac{\alpha_0 + \alpha_1 \bar{h} + \dots + \alpha_{l-1} \bar{h}^{l-1}}{\beta_0 + \beta_1 \bar{h} + \dots + \beta_l \bar{h}^l} : \alpha_k, \beta_m \in \mathbb{F}_p, (\beta_0, \dots, \beta_l) \neq (0, \dots, 0) \right\} \quad (4.90)$$

$$\bar{h}_{22} \notin B \triangleq \left\{ \frac{\alpha_0 + \alpha_1 \bar{h} + \dots + \alpha_l \bar{h}^l}{\beta_0 + \beta_1 \bar{h} + \dots + \beta_{l-1} \bar{h}^{l-1}} : \alpha_k, \beta_m \in \mathbb{F}_p, (\beta_0, \dots, \beta_{l-1}) \neq (0, \dots, 0) \right\} \quad (4.91)$$

$$\bar{h}_{33} \notin C \triangleq \left\{ \frac{\alpha_0 + \alpha_1 \bar{h} + \dots + \alpha_l \bar{h}^l}{\beta_0 + \beta_1 \bar{h} + \dots + \beta_{l-1} \bar{h}^{l-1}} : \alpha_k, \beta_m \in \mathbb{F}_p, (\beta_0, \dots, \beta_{l-1}) \neq (0, \dots, 0) \right\} \quad (4.92)$$

$$\beta_l \bar{h}^l + \dots + \beta_1 \bar{h} + \beta_0 \neq 0 : \beta_0, \dots, \beta_l \in \mathbb{F}_p, (\beta_0, \dots, \beta_l) \neq (0, \dots, 0) \quad (4.93)$$

The outer bound on linear capacity is presented in Appendix II, Section 4.3.6. The achievable scheme is presented next, which is summarized in Table 4.2.

4.3.5 Achievability

Over $\mathbb{F}_{p^{2l+1}}$, we will show that $3l + 1$ symbols can be transmitted ($l + 1$ symbols from source 1 and l symbols each from sources 2 and 3), and all desired symbols are resolvable at the destinations. Symbol extensions will not be necessary here. Note that \bar{h} is equivalent to the T matrix used in the CJ scheme [9], since beamforming directions are identified with varying powers of \bar{h} . We will first discuss the achievable scheme over \mathbb{F}_{p^3} and then show how it extends to all odd n , $\mathbb{F}_{p^{2l+1}}$.

Achievability over \mathbb{F}_{p^3}

Proof: Let us consider the normalized 3-user interference channel over \mathbb{F}_{p^3} so that $\bar{h}_{11}, \bar{h}_{22}, \bar{h}_{33}, \bar{h} \in \mathbb{F}_{p^3}$. We will show that linear schemes can achieve the rate of $\frac{4}{3}$. Consider the finite field network wherein source 1 sends 2 symbols, $x_1^1, x_1^2 \in \mathbb{F}_p$, while sources 2 and 3 send only one symbol each, $x_2, x_3 \in \mathbb{F}_p$.

Because of the channel normalization, we use the same beamforming direction $v \in \mathbb{F}_{p^3}$ for symbols sent by sources 2 and 3, so that interference is aligned at destination 1 ($v_2 = v_3 = v$). At source 1, we use 2 beam forming directions $\bar{h}v$ and v so that, one symbol aligns at destination 2, and another aligns at destination 3 ($v_1^1 = v, v_1^2 = \bar{h}v$). With these choices for beamforming directions, the received symbols can be represented as

$$y_1 = \bar{h}_{11}(vx_1^1 + \bar{h}vx_1^2) + vx_2 + vx_3 \quad (4.94)$$

$$y_2 = vx_1^1 + \bar{h}vx_1^2 + \bar{h}_{22}vx_2 + vx_3 \quad (4.95)$$

$$y_3 = vx_1^1 + \bar{h}vx_1^2 + \bar{h}vx_2 + \bar{h}_{33}vx_3 \quad (4.96)$$

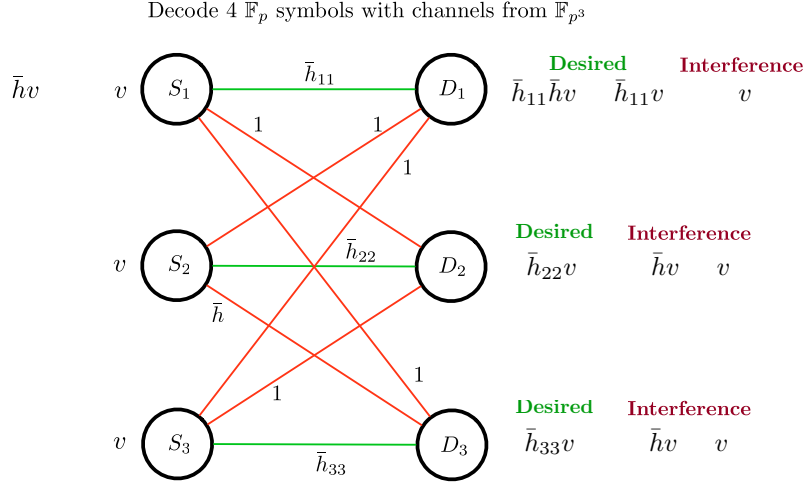

Figure 4.8: 3-user Interference channel over \mathbb{F}_{p^3}

Note that interference is aligned along v at destinations 1 and 2, while interference at destination 3 is aligned along $\bar{h}v$. We have 3 dimensions at each destination over \mathbb{F}_p , within which desired and interference symbols need to be resolved. Signal spaces containing desired and interference symbols need to have linearly independent elements.

$$S_1 = [\bar{h}_{11}\bar{h}v \quad \bar{h}_{11}v \quad v] = \bar{h}_{11}[\bar{h} \quad 1 \quad \frac{1}{\bar{h}_{11}}]v \quad (4.97)$$

$$S_2 = [\bar{h}_{22}v \quad \bar{h}v \quad v] = [\bar{h}_{22} \quad \bar{h} \quad 1]v \quad (4.98)$$

$$S_3 = [\bar{h}_{33}v \quad \bar{h}v \quad v] = [\bar{h}_{33} \quad \bar{h} \quad 1]v \quad (4.99)$$

When $\bar{h} \notin \mathbb{F}_p$, \bar{h} and 1 are linearly independent over \mathbb{F}_p . Hence, elements of S_1 can be linearly dependent only if $\frac{1}{\bar{h}_{11}}$ is a linear combination of \bar{h} and 1. Similarly elements of S_2 and S_3 can be linearly dependent only if \bar{h}_{22} or \bar{h}_{33} is a linear combination of \bar{h} and 1, respectively. Thus, the

scheme works when the following conditions are satisfied.

$$\bar{h}_{11} \notin A \triangleq \left\{ \frac{1}{\beta_0 + \beta_1 \bar{h}} : \beta_0, \beta_1 \in \mathbb{F}_p, (\beta_0, \beta_1) \neq (0, 0) \right\} \cup \{0\} \quad (4.100)$$

$$\bar{h}_{22} \notin B \triangleq \{ \alpha_0 + \alpha_1 \bar{h} : \alpha_0, \alpha_1 \in \mathbb{F}_p \} \quad (4.101)$$

$$\bar{h}_{33} \notin C \triangleq \{ \alpha_0 + \alpha_1 \bar{h} : \alpha_0, \alpha_1 \in \mathbb{F}_p \} \quad (4.102)$$

$$\bar{h} \notin \mathbb{F}_p \quad (4.103)$$

Hence we can achieve the rate of $4 \mathbb{F}_p$ symbols per channel use, i.e., $\frac{4}{3} \mathbb{F}_{p^3}$ symbols per channel use. Fig. 4.8 illustrates the achievable scheme described for \mathbb{F}_{p^3} .

Remark 5. We can rewrite the conditions in terms of original channel coefficients as follows.

$$\frac{1}{h_{11}} \notin A \triangleq \left\{ \alpha_1 \frac{h_{32}}{h_{12}h_{31}} + \beta_1 \frac{h_{23}}{h_{13}h_{21}} : \alpha_1, \beta_1 \in \mathbb{F}_p \right\} \quad (4.104)$$

$$h_{22} \notin B \triangleq \left\{ \alpha_2 \frac{h_{21}h_{32}}{h_{31}} + \beta_2 \frac{h_{12}h_{23}}{h_{13}} : \alpha_2, \beta_2 \in \mathbb{F}_p \right\} \quad (4.105)$$

$$h_{33} \notin C \triangleq \left\{ \alpha_3 \frac{h_{13}h_{32}}{h_{12}} + \beta_3 \frac{h_{31}h_{23}}{h_{21}} : \alpha_3, \beta_3 \in \mathbb{F}_p \right\} \quad (4.106)$$

These conditions, which are obtained for the constant channel setting, are similar to the conditions for feasibility of PBNA derived in [38] for the time-varying setting, wherein 6 cofactors of off-diagonal channel coefficients are involved in the feasibility criteria. However, note that in this finite field channel, the combining coefficients $\alpha_k, \beta_k, k \in \{1, 2, 3\}$ can be from \mathbb{F}_p whereas in [38], only binary coefficients were involved.

Remark 6. Each of the direct channels h_{ii} can take one of p^3 values. At most p^2 of these can be linear combination of the cross channel functions. Hence, there are at least $p^3 - p^2$ choices for each direct channel such that the linear independence conditions are met and so desired symbols are resolvable. The fraction of channel realizations for which h_{ii} is not a linear combination of

Decode $3l + 1$ \mathbb{F}_p symbols with channels from $\mathbb{F}_{p^n}, n = 2l + 1$

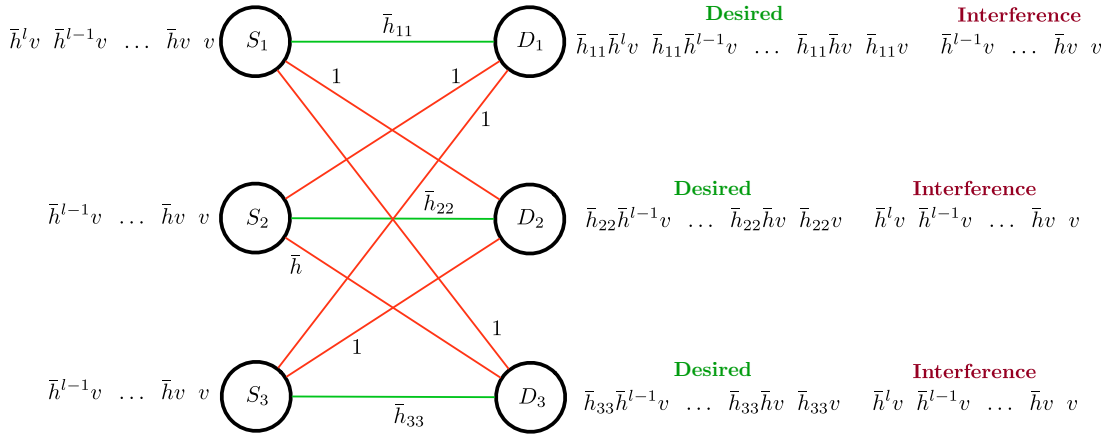

Figure 4.9: 3-user Interference channel over $\mathbb{F}_{p^n}, n = 2l + 1$

cross channel functions, is therefore at least

$$\frac{p^3 - p^2}{p^3} = 1 - \frac{1}{p} \rightarrow 1 \text{ for large } p \quad (4.107)$$

The fraction of channels for which the scheme works, considering all conditions simultaneously is therefore at least

$$\left(\frac{p^3 - p}{p^3}\right) \times \left(1 - \frac{1}{p}\right)^3 = \left(1 - \frac{1}{p^2}\right) \times \left(1 - \frac{1}{p}\right)^3 \rightarrow 1 \text{ for large } p \quad (4.108)$$

Note that unlike the wireless case where the DoF results are proved in an almost surely sense, the guarantee on the fraction of channels for which the scheme works is much more interesting.

Achievability over $\mathbb{F}_{p^n}, n = 2l + 1$

Proof: Now let us show that the sum-rate of $\frac{3l+1}{2l+1}$ can be achieved over $\mathbb{F}_{p^{2l+1}}$, which generalizes the proof for \mathbb{F}_{p^3} discussed earlier, to any odd n . Suppose source 1 sends $l + 1$ symbols, $x_1^1, x_1^2, \dots, x_1^{l+1} \in \mathbb{F}_p$, while sources 2 and 3 sends l symbols each, $x_2^1, \dots, x_2^l, x_3^1, \dots, x_3^l \in \mathbb{F}_p$.

We use the same set of beamforming directions, $\bar{h}^{l-1}v, \dots, \bar{h}v, v$ with $v \in \mathbb{F}_{p^{2l+1}}$ for the l symbols sent by sources 2 and 3, so that interference is aligned at destination 1 in $\text{span}([\bar{h}^{l-1}v \ \dots \ \bar{h}v \ v])$. At source 1, we use $l + 1$ beamforming directions $\bar{h}^l v, \dots, \bar{h}v, v$ so that, l symbols align at destination 2, and l symbols align at destination 3. With these choices of beamforming directions for input symbols, the received symbols at the destinations can be represented as

$$y_1 = \bar{h}_{11}(\bar{h}^l v x_1^{l+1} + \dots + \bar{h}v x_1^2 + v x_1^1) + \bar{h}^{l-1}v x_2^l + \dots + v x_2^1 + \bar{h}^{l-1}v x_3^l + \dots + v x_3^1 \quad (4.109)$$

$$y_2 = \bar{h}_{22}(\bar{h}^{l-1}v x_2^l + \dots + v x_2^1) + \bar{h}^{l-1}v x_3^l + \dots + v x_3^1 + \bar{h}^l v x_1^{l+1} + \dots + \bar{h}v x_1^2 + v x_1^1 \quad (4.110)$$

$$y_3 = \bar{h}_{33}(\bar{h}^{l-1}v x_3^l + \dots + v x_3^1) + \bar{h}^{l-1}v x_2^l + \dots + v x_2^1 + \bar{h}^l v x_1^{l+1} + \dots + \bar{h}v x_1^2 + v x_1^1 \quad (4.111)$$

In order to resolve desired symbols at the destinations, signal spaces containing desired and interference symbols need to have linearly independent entries.

$$S_1 = [\bar{h}_{11}\bar{h}^l v \ \dots \ \bar{h}_{11}\bar{h}v \ \bar{h}_{11}v \ \bar{h}^{l-1}v \ \dots \ \bar{h}v \ v] = [\bar{h}_{11}\bar{h}^l \ \dots \ \bar{h}_{11}\bar{h} \ \bar{h}_{11} \ \bar{h}^{l-1} \ \dots \ \bar{h} \ 1]v \quad (4.112)$$

$$S_2 = [\bar{h}_{22}\bar{h}^{l-1}v \ \dots \ \bar{h}_{22}\bar{h}v \ \bar{h}_{22}v \ \bar{h}^l v \ \dots \ \bar{h}v \ v] = [\bar{h}_{22}\bar{h}^{l-1} \ \dots \ \bar{h}_{22}\bar{h} \ \bar{h}_{22} \ \bar{h}^l \ \dots \ \bar{h} \ 1]v \quad (4.113)$$

$$S_3 = [\bar{h}_{33}\bar{h}^{l-1}v \ \dots \ \bar{h}_{33}\bar{h}v \ \bar{h}_{33}v \ \bar{h}^l v \ \dots \ \bar{h}v \ v] = [\bar{h}_{33}\bar{h}^{l-1} \ \dots \ \bar{h}_{33}\bar{h} \ \bar{h}_{33} \ \bar{h}^l \ \dots \ \bar{h} \ 1]v \quad (4.114)$$

The desired and interference symbols are resolvable and $3l + 1$ symbols can be decoded at the destinations when the following conditions are satisfied.

$$\bar{h}_{11} \notin A \triangleq \left\{ \frac{\alpha_0 + \alpha_1 \bar{h} + \dots + \alpha_{l-1} \bar{h}^{l-1}}{\beta_0 + \beta_1 \bar{h} + \dots + \beta_l \bar{h}^l} : \alpha_k, \beta_m \in \mathbb{F}_p, (\beta_0, \dots, \beta_l) \neq (0, \dots, 0) \right\} \quad (4.115)$$

$$\bar{h}_{22} \notin B \triangleq \left\{ \frac{\alpha_0 + \alpha_1 \bar{h} + \dots + \alpha_l \bar{h}^l}{\beta_0 + \beta_1 \bar{h} + \dots + \beta_{l-1} \bar{h}^{l-1}} : \alpha_k, \beta_m \in \mathbb{F}_p, (\beta_0, \dots, \beta_{l-1}) \neq (0, \dots, 0) \right\} \quad (4.116)$$

$$\bar{h}_{33} \notin C \triangleq \left\{ \frac{\alpha_0 + \alpha_1 \bar{h} + \dots + \alpha_l \bar{h}^l}{\beta_0 + \beta_1 \bar{h} + \dots + \beta_{l-1} \bar{h}^{l-1}} : \alpha_k, \beta_m \in \mathbb{F}_p, (\beta_0, \dots, \beta_{l-1}) \neq (0, \dots, 0) \right\} \quad (4.117)$$

$$\beta_l \bar{h}^l + \dots + \beta_1 \bar{h} + \beta_0 \neq 0 : \beta_0, \dots, \beta_l \in \mathbb{F}_p, (\beta_0, \dots, \beta_l) \neq (0, \dots, 0) \quad (4.118)$$

Fig. 4.9 illustrates the achievable scheme described for \mathbb{F}_{p^n} with $n = 2l + 1$. Note that a \mathbb{F}_p symbol represents $\frac{1}{2l+1}$ of an $\mathbb{F}_{p^{2l+1}}$ symbol and rate is measured in $\mathbb{F}_{p^{2l+1}}$ units. Hence we have proved achievability of linear capacity of $\frac{3l+1}{2l+1}$ for all odd $n = 2l + 1$.

Remark 7. Each of the direct channels h_{ii} can be from one of the p^{2l+1} choices. The fraction of channel realizations for which direct channels satisfy the conditions is at least

$$\begin{aligned} \text{Fraction of channels with } h_{11} \text{ not in A} &\geq \frac{p^{2l+1} - (p^{2l} + \dots + p^l)}{p^{2l+1}} \\ &= 1 - \left\{ \frac{1}{p} + \frac{1}{p^2} + \dots + \frac{1}{p^{l+1}} \right\} \rightarrow 1 \text{ for large } p \end{aligned} \quad (4.119)$$

$$\begin{aligned} \text{Fraction of channels with } h_{22} \text{ or } h_{33} \text{ not in B or C} &\geq \frac{p^{2l+1} - (p^{2l} + \dots + p^{l+1})}{p^{2l+1}} \\ &= 1 - \left\{ \frac{1}{p} + \frac{1}{p^2} + \dots + \frac{1}{p^l} \right\} \rightarrow 1 \text{ for large } p \end{aligned} \quad (4.120)$$

Also, following condition on cross channel \bar{h} needs to be met

$$\beta_l \bar{h}^l + \dots + \beta_1 \bar{h} + \beta_0 \neq 0 : \quad \beta_0, \dots, \beta_l \in \mathbb{F}_p, (\beta_0, \dots, \beta_l) \neq (0, \dots, 0) \quad (4.121)$$

The $l + 1$ combining coefficients can represent no more than p^{l+1} distinct polynomials, and since each has degree l or less, each polynomial can have at most l zeros. Therefore, the number of possible \bar{h} that can violate (4.121) is no more than lp^{l+1} . So, the fraction of \bar{h} values for which the scheme works is at least

$$\frac{p^{2l+1} - lp^{l+1}}{p^{2l+1}} = 1 - \frac{l}{p^l} \quad (4.122)$$

which approaches 1 as either p or l approaches infinity. Putting everything together, the fraction of all channels for which the scheme works is at least

$$\left(1 - \frac{l}{p^l}\right) \left(1 - \left\{\frac{1}{p} + \frac{1}{p^2} + \dots + \frac{1}{p^{l+1}}\right\}\right) \left(1 - \left\{\frac{1}{p} + \frac{1}{p^2} + \dots + \frac{1}{p^l}\right\}\right)^2 \rightarrow 1 \text{ for large } p \quad (4.123)$$

Achievability over \mathbb{F}_{p^2}

Having established the achievability proof over \mathbb{F}_{p^n} for odd n , we will omit the general case of even n , except to mention that it can be translated from [8] using the same principles as illustrated for odd n and does not offer new insights. However, we will present the achievability proof for the case of $n = 2$ because the corresponding result in [12] uses the asymmetric complex signaling approach which may be of interest. As before, \mathbb{F}_{p^2} can be viewed as a 2-dimensional vector space over subfield \mathbb{F}_p , much like the field of complex numbers can be viewed as a 2-dimensional vector space over reals, so that an achievable scheme similar to asymmetric complex signaling of [12] can be used. Hence, we translate the DoF result of [12] into the finite field setting as follows.

THEOREM 4.5. *The 3-user interference channel over \mathbb{F}_{p^2} has linear capacity, $C_{linear} = \frac{6}{5}$, if*

$$\bar{h}_{11} = \frac{h_{11}h_{23}}{h_{13}h_{21}} \notin \mathbb{F}_p, \quad \bar{h}_{22} = \frac{h_{22}h_{13}}{h_{23}h_{12}} \notin \mathbb{F}_p, \quad \bar{h}_{33} = \frac{h_{33}h_{21}}{h_{31}h_{23}} \notin \mathbb{F}_p \quad (4.124)$$

$$\bar{h}\bar{h}_{11} = \frac{h_{11}h_{32}}{h_{12}h_{31}} \notin \mathbb{F}_p, \quad \frac{\bar{h}}{\bar{h}_{22}} = \frac{h_{21}h_{32}}{h_{22}h_{31}} \notin \mathbb{F}_p, \quad \frac{\bar{h}}{\bar{h}_{33}} = \frac{h_{32}h_{13}}{h_{33}h_{12}} \notin \mathbb{F}_p \quad (4.125)$$

Proof: The outer bound follows from [12] (Theorem 4) in much the same fashion as the outer bound for the previous section follows from [8] (Theorem 7). Here we present only the achievability proof. Consider a 5 symbol extension of the normalized 3-user interference channel over \mathbb{F}_{p^2} . Over these 5 symbol extensions, 4 input symbols denoted by $x_k^1, x_k^2, x_k^3, x_k^4$ are precoded and transmitted at source k . Each input symbol $x_k^i, i \in \{1, 2, 3, 4\}, k \in \{1, 2, 3\}$ is from \mathbb{F}_p . Corresponding 5×1 beam forming vectors are denoted using vectors $\mathbf{v}_k^1, \mathbf{v}_k^2, \mathbf{v}_k^3, \mathbf{v}_k^4 \in \mathbb{F}_{p^2}^{5 \times 1}, k \in \{1, 2, 3\}$. Each destination has 10 dimensions of order p over the symbol extended channel. Desired symbols from corresponding source would occupy 4 dimensions and for resolvability, interference need to occupy only 6 dimensions of order p . Hence at each destination, two of the 8 interference vectors from 2 unintended sources, need to be aligned. To this end, we make the following choices for certain beam forming vectors.

$$\mathbf{v}_1^3 = \bar{h}\mathbf{v}_2^1, \quad \mathbf{v}_1^4 = \mathbf{v}_3^2, \quad \mathbf{v}_2^3 = \mathbf{v}_3^1, \quad \mathbf{v}_2^4 = \frac{1}{h}\mathbf{v}_1^2, \quad \mathbf{v}_3^3 = \mathbf{v}_1^1, \quad \mathbf{v}_3^4 = \mathbf{v}_2^2 \quad (4.126)$$

Desired and Interference signal space at the three destinations are illustrated in Fig. 4.10. Due to interference alignment, these signal space matrices can be equivalently re-written as

$$S_1 = \begin{bmatrix} \bar{h}_{11} [\mathbf{v}_1^1 & \mathbf{v}_1^2 & \bar{h}\mathbf{v}_2^1 & \mathbf{v}_3^2] & \mathbf{v}_2^1 & \mathbf{v}_2^2 & \mathbf{v}_3^1 & \frac{1}{h}\mathbf{v}_1^2 & \mathbf{v}_3^2 & \mathbf{v}_1^1 \end{bmatrix} \quad (4.127)$$

$$S_2 = \begin{bmatrix} \bar{h}_{22} [\mathbf{v}_2^1 & \mathbf{v}_2^2 & \mathbf{v}_3^1 & \frac{1}{h}\mathbf{v}_1^2] & \mathbf{v}_3^1 & \mathbf{v}_3^2 & \mathbf{v}_1^1 & \mathbf{v}_2^2 & \mathbf{v}_1^2 & \bar{h}\mathbf{v}_2^1 \end{bmatrix} \quad (4.128)$$

$$S_3 = \begin{bmatrix} \bar{h}_{33} [\mathbf{v}_3^1 & \mathbf{v}_3^2 & \mathbf{v}_1^1 & \mathbf{v}_2^2] & \mathbf{v}_1^1 & \mathbf{v}_1^2 & \bar{h}\mathbf{v}_2^1 & \mathbf{v}_3^2 & \bar{h}\mathbf{v}_2^2 & \bar{h}\mathbf{v}_3^1 \end{bmatrix} \quad (4.129)$$

In order to resolve desired signals at all destinations, the columns of these 3 matrices need to be linearly independent over \mathbb{F}_p . Note that the following six conditions are required.

$$\bar{h}_{11} \notin \mathbb{F}_p, \quad \bar{h}_{22} \notin \mathbb{F}_p, \quad \bar{h}_{33} \notin \mathbb{F}_p, \quad \bar{h}\bar{h}_{11} \notin \mathbb{F}_p, \quad \frac{\bar{h}}{\bar{h}_{22}} \notin \mathbb{F}_p, \quad \frac{\bar{h}}{\bar{h}_{33}} \notin \mathbb{F}_p \quad (4.130)$$

Decode $12 \mathbb{F}_p$ symbols over 5 symbol extensions of channel

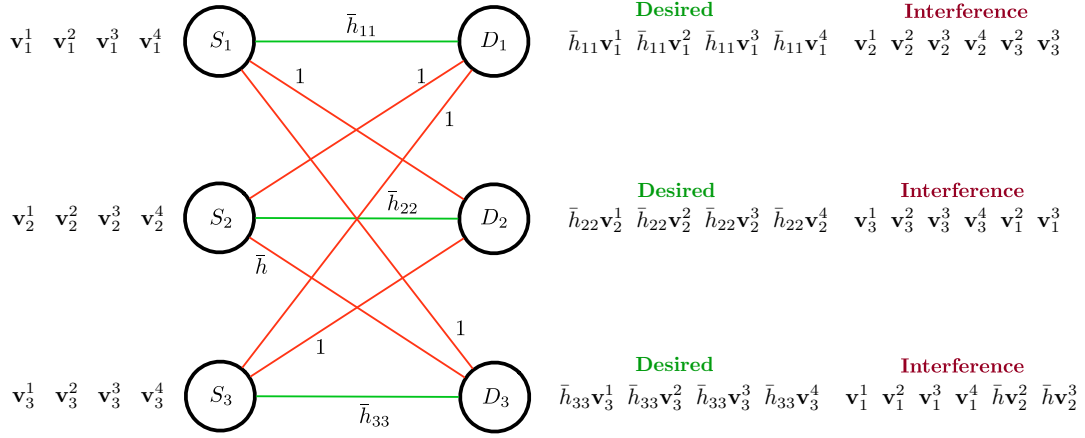

Figure 4.10: 3-user Interference channel over \mathbb{F}_{p^2}

We will now choose beam forming vectors $\mathbf{v}_k^i, i \in \{1, 2\}, k \in \{1, 2, 3\}$, such that all three matrices S_k have their 10 columns linearly independent.

We choose \mathbf{v}_1^1 to be the vector of ones. Since $\bar{h}_{11}, \bar{h}_{33} \notin \mathbb{F}_p$, vectors in $S_1 : [\bar{h}_{11}\mathbf{v}_1^1 \ \mathbf{v}_1^1]$ are linearly independent and so are similar vectors in $S_3 : [\bar{h}_{33}\mathbf{v}_1^1 \ \mathbf{v}_1^1]$. We now choose vector \mathbf{v}_1^2 such that following conditions hold.

$$\text{From } S_1, \mathbf{v}_1^2 \notin A \triangleq \left\{ \frac{(\alpha_1 \bar{h}_{11} + \alpha_2) \mathbf{v}_1^1}{\beta_1 \bar{h}_{11} + \beta_2 \frac{1}{h}} : \alpha_1, \alpha_2, \beta_1, \beta_2 \in \mathbb{F}_p, (\beta_1, \beta_2) \neq (0, 0) \right\} \quad (4.131)$$

$$\text{From } S_2, \mathbf{v}_1^2 \notin B \triangleq \left\{ \frac{\alpha_1 \mathbf{v}_1^1}{\beta_1 + \beta_2 \frac{\bar{h}_{22}}{h}} : \alpha_1, \beta_1, \beta_2 \in \mathbb{F}_p, (\beta_1, \beta_2) \neq (0, 0) \right\} \quad (4.132)$$

$$\text{From } S_3, \mathbf{v}_1^2 \notin C \triangleq \left\{ (\alpha_1 \bar{h}_{33} + \alpha_2) \mathbf{v}_1^1 : \alpha_1, \alpha_2 \in \mathbb{F}_p \right\} \quad (4.133)$$

Now we note that

$$|A| \leq \frac{(p^2 - 1)p^2}{p - 1} = p^3 + p^2 \quad |B| \leq \frac{(p^2 - 1)p}{p - 1} = p^2 + p, \quad |C| \leq p^2 \quad (4.134)$$

$$|A \cup B \cup C| \leq p^3 + 3p^2 + p \quad (4.135)$$

There are p^{10} choices for $\mathbf{v}_1^2 \in \mathbb{F}_p^{5 \times 1}$, and since

$$p^{10} > p^3 + 3p^2 + p \quad (4.136)$$

for all p , there exist choices for \mathbf{v}_1^2 such that all 3 conditions (4.131),(4.132),(4.133) hold. Choosing \mathbf{v}_1^2 from those, we note that 4 columns of S_1 and 3 columns each of S_2, S_3 are linearly independent over \mathbb{F}_p .

Now we choose \mathbf{v}_2^1 similarly such that following conditions hold

$$\mathbf{v}_2^1 \notin A \triangleq \left\{ \frac{(\alpha_1 \bar{h}_{11} + \alpha_2) \mathbf{v}_1^1 + (\alpha_3 \bar{h}_{11} + \frac{1}{h} \alpha_4) \mathbf{v}_1^2}{\beta_1 \bar{h}_{11} \bar{h} + \beta_2} : \alpha_1, \alpha_2, \alpha_3, \alpha_4, \beta_1, \beta_2 \in \mathbb{F}_p, \right. \\ \left. (\beta_1, \beta_2) \neq (0, 0) \right\} \quad (4.137)$$

$$\mathbf{v}_2^1 \notin B \triangleq \left\{ \frac{\alpha_1 \mathbf{v}_1^1 + (\alpha_2 + \alpha_3 \frac{\bar{h}_{22}}{h}) \mathbf{v}_1^2}{\beta_1 \bar{h}_{22} + \beta_2 \bar{h}} : \alpha_1, \alpha_2, \alpha_3, \beta_1, \beta_2 \in \mathbb{F}_p, (\beta_1, \beta_2) \neq (0, 0) \right\} \quad (4.138)$$

$$\mathbf{v}_2^1 \notin C \triangleq \left\{ \frac{(\alpha_1 \bar{h}_{33} + \alpha_2) \mathbf{v}_1^1 + \alpha_3 \mathbf{v}_1^2}{\bar{h}} : \alpha_1, \alpha_2, \alpha_3 \in \mathbb{F}_p \right\} \quad (4.139)$$

Now we note that

$$|A| \leq \frac{(p^2 - 1)p^4}{p - 1} = p^5 + p^4 \quad |B| \leq \frac{(p^2 - 1)p^3}{p - 1} = p^4 + p^3, \quad |C| \leq p^3 \quad (4.140)$$

$$|A \cup B \cup C| \leq p^5 + 2p^4 + 2p^3 \quad (4.141)$$

There are p^{10} choices for \mathbf{v}_2^1 , and since

$$p^{10} > p^5 + 2p^4 + 2p^3 \quad (4.142)$$

for all p , there exist choices for \mathbf{v}_2^1 such that all 3 conditions (4.137),(4.138),(4.139) hold. Choosing \mathbf{v}_2^1 from those, we note that 6 columns of S_1 , 5 columns of S_2 and 4 columns of S_3 are linearly independent over \mathbb{F}_p .

Now we choose \mathbf{v}_2^2 similarly such that following conditions hold

$$\mathbf{v}_2^2 \notin A \triangleq \left\{ (\alpha_1 \bar{h}_{11} + \alpha_2) \mathbf{v}_1^1 + (\alpha_3 \bar{h}_{11} + \frac{1}{h} \alpha_4) \mathbf{v}_1^2 + (\alpha_5 \bar{h}_{11} \bar{h} + \alpha_6) \mathbf{v}_2^1 : \alpha_k \in \mathbb{F}_p, \right. \\ \left. k \in \{1, \dots, 6\} \right\} \quad (4.143)$$

$$\mathbf{v}_2^2 \notin B \triangleq \left\{ \frac{1}{\beta_1 \bar{h}_{22} + \beta_2} (\alpha_1 \mathbf{v}_1^1 + (\alpha_2 + \alpha_3 \frac{\bar{h}_{22}}{h}) \mathbf{v}_1^2 + (\alpha_4 \bar{h} + \alpha_5 \bar{h}_{22}) \mathbf{v}_2^1) : \right. \\ \left. \alpha_k, \beta_1, \beta_2 \in \mathbb{F}_p, k \in \{1, \dots, 5\}, (\beta_1, \beta_2) \neq (0, 0) \right\} \quad (4.144)$$

$$\mathbf{v}_2^2 \notin C \triangleq \left\{ \frac{1}{\beta_1 \bar{h}_{33} + \beta_2 \bar{h}} ((\alpha_1 \bar{h}_{33} + \alpha_2) \mathbf{v}_1^1 + \alpha_3 \mathbf{v}_1^2 + \alpha_4 \bar{h} \mathbf{v}_2^1) : \alpha_k, \beta_1, \beta_2 \in \mathbb{F}_p, \right. \\ \left. k \in \{1, \dots, 4\}, (\beta_1, \beta_2) \neq (0, 0) \right\} \quad (4.145)$$

Now we note that

$$|A| \leq p^6, \quad |B| \leq \frac{(p^2 - 1)p^5}{p - 1} = p^6 + p^5, \quad |C| \leq \frac{(p^2 - 1)p^4}{p - 1} = p^5 + p^4 \quad (4.146)$$

$$|A \cup B \cup C| \leq 2p^6 + 2p^5 + p^4 \quad (4.147)$$

There are p^{10} choices for \mathbf{v}_2^2 , and since

$$p^{10} > 2p^6 + 2p^5 + p^4 \quad (4.148)$$

for all p , there exist choices for \mathbf{v}_2^2 such that all 3 conditions (4.143),(4.144),(4.145) hold. Choosing \mathbf{v}_2^2 from those, we note that 7 columns each of S_1, S_2 , and 6 columns of S_3 are linearly independent over \mathbb{F}_p .

Now we choose \mathbf{v}_3^1 similarly such that following conditions hold

$$\mathbf{v}_3^1 \notin A \triangleq \left\{ (\alpha_1 \bar{h}_{11} + \alpha_2) \mathbf{v}_1^1 + (\alpha_3 \bar{h}_{11} + \frac{1}{\bar{h}} \alpha_4) \mathbf{v}_1^2 + (\alpha_5 \bar{h}_{11} \bar{h} + \alpha_6) \mathbf{v}_2^1 + \alpha_7 \mathbf{v}_2^2 : \right. \\ \left. \alpha_k \in \mathbb{F}_p, k \in \{1, \dots, 7\} \right\} \quad (4.149)$$

$$\mathbf{v}_3^1 \notin B \triangleq \left\{ \frac{1}{\beta_1 \bar{h}_{22} + \beta_2} (\alpha_1 \mathbf{v}_1^1 + (\alpha_2 + \alpha_3 \frac{\bar{h}_{22}}{\bar{h}}) \mathbf{v}_1^2 + (\alpha_4 \bar{h} + \alpha_5 \bar{h}_{22}) \mathbf{v}_2^1 + \right. \\ \left. (\alpha_6 \bar{h}_{22} + \alpha_7) \mathbf{v}_2^2) : \alpha_k, \beta_1, \beta_2 \in \mathbb{F}_p, k \in \{1, \dots, 7\}, (\beta_1, \beta_2) \neq (0, 0) \right\} \quad (4.150)$$

$$\mathbf{v}_3^1 \notin C \triangleq \left\{ \frac{1}{\beta_1 \bar{h}_{33} + \beta_2 \bar{h}} ((\alpha_1 \bar{h}_{33} + \alpha_2) \mathbf{v}_1^1 + \alpha_3 \mathbf{v}_1^2 + \alpha_4 \bar{h} \mathbf{v}_2^1 + (\alpha_5 \bar{h}_{33} + \alpha_6 \bar{h}) \mathbf{v}_2^2) : \right. \\ \left. \alpha_k, \beta_1, \beta_2 \in \mathbb{F}_p, k \in \{1, \dots, 6\}, (\beta_1, \beta_2) \neq (0, 0) \right\} \quad (4.151)$$

Now we note that

$$|A| \leq p^7, \quad |B| \leq \frac{(p^2 - 1)p^7}{p - 1} = p^8 + p^7 \quad |C| \leq \frac{(p^2 - 1)p^6}{p - 1} = p^7 + p^6 \quad (4.152)$$

$$|A \cup B \cup C| \leq p^8 + 3p^7 + p^6 \quad (4.153)$$

There are p^{10} choices for \mathbf{v}_3^1 , and since

$$p^{10} > p^8 + 3p^7 + p^6 \quad (4.154)$$

for all p , there exist choices for \mathbf{v}_3^1 such that all 3 conditions (4.149),(4.150),(4.151) hold. Choosing \mathbf{v}_3^1 from those, we note that 8 columns each of S_1, S_3 , and 9 columns of S_2 are linearly independent over \mathbb{F}_p .

Now we choose \mathbf{v}_3^2 similarly such that following conditions hold

$$\mathbf{v}_3^2 \notin A \triangleq \left\{ \frac{1}{\beta_1 \bar{h}_{11} + \beta_2} \left((\alpha_1 \bar{h}_{11} + \alpha_2) \mathbf{v}_1^1 + (\alpha_3 \bar{h}_{11} + \frac{1}{h} \alpha_4) \mathbf{v}_1^2 + (\alpha_5 \bar{h}_{11} \bar{h} + \alpha_6) \mathbf{v}_2^1 + \alpha_7 \mathbf{v}_2^2 + \alpha_8 \mathbf{v}_3^1 \right) : \alpha_k \in \mathbb{F}_p, k \in \{1, \dots, 8\}, (\beta_1, \beta_2) \neq (0, 0) \right\} \quad (4.155)$$

$$\mathbf{v}_3^2 \notin B \triangleq \left\{ \alpha_1 \mathbf{v}_1^1 + \left(\alpha_2 + \alpha_3 \frac{\bar{h}_{22}}{h} \right) \mathbf{v}_1^2 + (\alpha_4 \bar{h} + \alpha_5 \bar{h}_{22}) \mathbf{v}_2^1 + (\alpha_6 \bar{h}_{22} + \alpha_7) \mathbf{v}_2^2 + (\alpha_8 \bar{h}_{22} + \alpha_9) \mathbf{v}_3^1 : \alpha_k, \beta_1, \beta_2 \in \mathbb{F}_p, k \in \{1, \dots, 9\} \right\} \quad (4.156)$$

$$\mathbf{v}_3^2 \notin C \triangleq \left\{ \frac{1}{\beta_1 \bar{h}_{33} + \beta_2} \left((\alpha_1 \bar{h}_{33} + \alpha_2) \mathbf{v}_1^1 + \alpha_3 \mathbf{v}_1^2 + \alpha_4 \bar{h} \mathbf{v}_2^1 + (\alpha_5 \bar{h}_{33} + \alpha_6 \bar{h}) \mathbf{v}_2^2 + (\alpha_7 \bar{h}_{33} + \alpha_8 \bar{h}) \mathbf{v}_3^1 \right) : \alpha_k, \beta_1, \beta_2 \in \mathbb{F}_p, k \in \{1, \dots, 8\}, (\beta_1, \beta_2) \neq (0, 0) \right\} \quad (4.157)$$

Now we note that

$$|A| \leq \frac{(p^2 - 1)p^8}{p - 1} = p^9 + p^8, \quad |B| \leq p^9, \quad |C| \leq \frac{(p^2 - 1)p^8}{p - 1} = p^9 + p^8 \quad (4.158)$$

$$|A \cup B \cup C| \leq 3p^9 + 2p^8 \quad (4.159)$$

There are p^{10} choices for \mathbf{v}_3^2 , and since

$$p^{10} > 3p^9 + 2p^8 \quad (4.160)$$

for $p > 3$, there exist choices for \mathbf{v}_3^2 such that all 3 conditions (4.155),(4.156),(4.157) hold. Choosing \mathbf{v}_3^2 from those, we note that all columns each of S_1, S_2, S_3 are linearly independent over \mathbb{F}_p .

Therefore, we have constructed beam forming vectors such that desired and interference signals are linearly independent at all destinations. This proves the achievability of linear-scheme capacity of $\frac{6}{5}$ for 3-user interference channel over \mathbb{F}_{p^2} for all $p > 3$ when the specified conditions are met. For $p=2$ and $p=3$, we are able to solve numerically using MATLAB, completing the achievability proof of sum-rate $\frac{6}{5}$ for channel over \mathbb{F}_{p^2} for all p under the conditions of Theorem 4.5.

Remark 8. Conditions of Theorem 4.5 can be written in terms of the original channels as follows.

$$\bar{h}_{11} = \frac{h_{11}h_{23}}{h_{13}h_{21}} \notin \mathbb{F}_p, \quad \bar{h}_{22} = \frac{h_{22}h_{13}}{h_{23}h_{12}} \notin \mathbb{F}_p, \quad \bar{h}_{33} = \frac{h_{33}h_{21}}{h_{31}h_{23}} \notin \mathbb{F}_p \quad (4.161)$$

$$\bar{h}\bar{h}_{11} = \frac{h_{11}h_{32}}{h_{12}h_{31}} \notin \mathbb{F}_p, \quad \frac{\bar{h}}{\bar{h}_{22}} = \frac{h_{21}h_{32}}{h_{22}h_{31}} \notin \mathbb{F}_p, \quad \frac{\bar{h}}{\bar{h}_{33}} = \frac{h_{32}h_{13}}{h_{33}h_{12}} \notin \mathbb{F}_p \quad (4.162)$$

Note that these 6 conditions are equivalent to the 6 conditions on the phase differences between channel coefficients in the asymmetric complex signing scheme for wireless networks, as described in [12] (Theorem 2) to achieve DoF of $\frac{6}{5}$.

Remark 9. Each of the direct channels satisfy $\bar{h}_{ii} \notin \mathbb{F}_p, i \in \{1, 2, 3\}$ The fraction of channel realizations for which direct channels satisfy the 3 conditions is at least

$$\left(\frac{p^2 - p}{p^2}\right)^3 = \left(1 - \frac{1}{p}\right)^3 \rightarrow 1 \text{ for large } p \quad (4.163)$$

Further cross channel \bar{h} should satisfy the conditions $\bar{h} \neq \frac{\alpha}{h_{11}}, \bar{h} \neq \beta\bar{h}_{22}, \bar{h} \neq \gamma\bar{h}_{33}$ for $\alpha, \beta, \gamma \in \mathbb{F}_p$. There are atmost $3p$ channels such that one of these 3 conditions on \bar{h} is violated. Hence there are at least $p^2 - 3p$ valid channel realizations for \bar{h} for $p > 3$. Putting everything together, the fraction of all channels for which the scheme works for $p > 3$ is at least

$$\left(1 - \frac{1}{p}\right)^3 \left(\frac{p^2 - 3p}{p^2}\right) = \left(1 - \frac{1}{p}\right)^3 \left(1 - \frac{3}{p}\right) \rightarrow 1 \text{ for large } p \quad (4.164)$$

4.3.6 Linear outer bound

In this section, we will prove the linear outer bounds for 3-user interference channel over \mathbb{F}_{p^n} . The proof follows along the lines of [8] (Theorem 7) by showing that the alignment depth can be at most D , which is a function of channel diversity (in case of finite fields, n).

Linear outer bound over $\mathbb{F}_{p^n}, n = 2l + 1$

Lemma 3. Alignment depth is at most $D = 2n - \lfloor \frac{n}{2} \rfloor - 1$ for the normalized 3-user interference channel, wherein channels $\bar{h}, \bar{h}_{kk} \in \mathbb{F}_{p^n}$ for odd $n = 2l + 1$ and satisfy

$$\bar{h}_{11} \notin A \triangleq \left\{ \frac{\alpha_0 + \alpha_1 \bar{h} + \dots + \alpha_{l-1} \bar{h}^{l-1}}{\beta_0 + \beta_1 \bar{h} + \dots + \beta_l \bar{h}^l} : \alpha_k, \beta_m \in \mathbb{F}_p, (\beta_0, \dots, \beta_l) \neq (0, \dots, 0) \right\} \quad (4.165)$$

$$\bar{h}_{22} \notin B \triangleq \left\{ \frac{\alpha_0 + \alpha_1 \bar{h} + \dots + \alpha_l \bar{h}^l}{\beta_0 + \beta_1 \bar{h} + \dots + \beta_{l-1} \bar{h}^{l-1}} : \alpha_k, \beta_m \in \mathbb{F}_p, (\beta_0, \dots, \beta_{l-1}) \neq (0, \dots, 0) \right\} \quad (4.166)$$

$$\bar{h}_{33} \notin C \triangleq \left\{ \frac{\alpha_0 + \alpha_1 \bar{h} + \dots + \alpha_l \bar{h}^l}{\beta_0 + \beta_1 \bar{h} + \dots + \beta_{l-1} \bar{h}^{l-1}} : \alpha_k, \beta_m \in \mathbb{F}_p, (\beta_0, \dots, \beta_{l-1}) \neq (0, \dots, 0) \right\} \quad (4.167)$$

$$\beta_l \bar{h}^l + \dots + \beta_1 \bar{h} + \beta_0 \neq 0 : \beta_0, \dots, \beta_l \in \mathbb{F}_p, (\beta_0, \dots, \beta_l) \neq (0, \dots, 0) \quad (4.168)$$

Proof: Let us consider the normalized channel as described in section 4.3.3 for odd $n = 2l + 1$, and at source 1, denote a vector \mathbf{v} of dimension $m \times 1$ with entries from \mathbb{F}_{p^n} . Since this is a converse proof, we assume that the desired symbols can be decoded at all the destinations. Here m denotes the number of symbol extensions of the channel. This vector of source 1 needs to be aligned with a vector from source 3 at destination 2, we can denote the vector at source 3 as $\gamma_1 \mathbf{v}$ with $\gamma_1 \in \mathbb{F}_p$. Vector $\gamma_1 \mathbf{v}$ aligns with a vector from source 2 at destination 1, say $\beta_1 \mathbf{v}$ with $\beta_1 \in \mathbb{F}_p$. Vector $\beta_1 \mathbf{v}$ aligns with a vector from source 1 at destination 3, say $\alpha_1 \bar{h} \mathbf{v}$ with $\alpha_1 \in \mathbb{F}_p$. So far, alignment chain length can be seen to be 4, and such an alignment chain can be extended upto length D when operating in field of order p^n . With $n = 2l + 1$ this results in source 1 using $l + 1$ vectors, and sources 2 and 3 using l vectors each such that the alignment chain length is $D = 3l + 1$. Then the vectors chosen so far at the 3 sources can be represented as

$$V_1 = [\alpha_l \bar{h}^l \mathbf{v} \quad \alpha_{l-1} \bar{h}^{l-1} \mathbf{v} \quad \dots \quad \alpha_1 \bar{h} \mathbf{v} \quad \mathbf{v}] \quad (4.169)$$

$$V_2 = [\beta_l \bar{h}^{l-1} \mathbf{v} \quad \beta_{l-1} \bar{h}^{l-2} \mathbf{v} \quad \dots \quad \beta_2 \bar{h} \mathbf{v} \quad \beta_1 \mathbf{v}] \quad (4.170)$$

$$V_3 = [\gamma_l \bar{h}^{l-1} \mathbf{v} \quad \gamma_{l-1} \bar{h}^{l-2} \mathbf{v} \quad \dots \quad \gamma_2 \bar{h} \mathbf{v} \quad \gamma_1 \mathbf{v}] \quad (4.171)$$

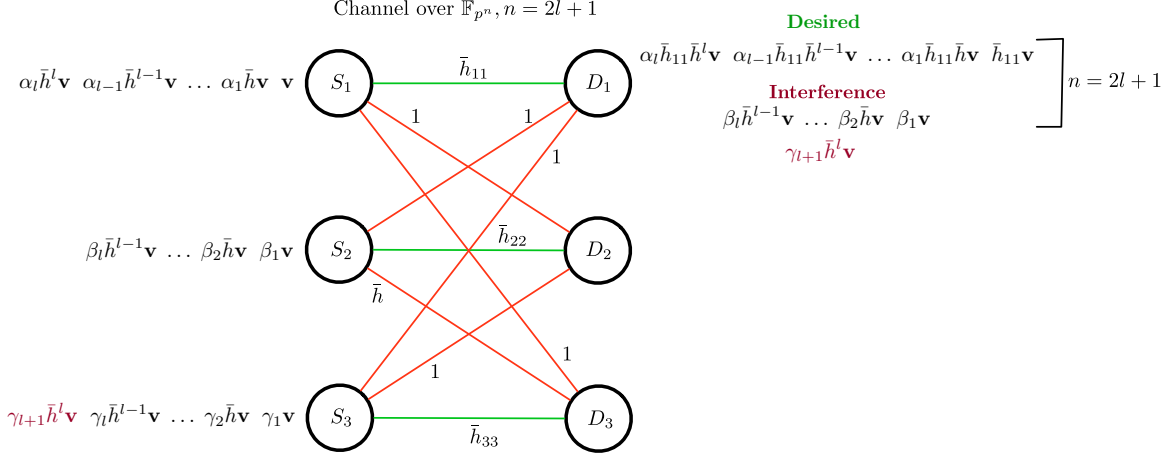

Figure 4.11: Alignment depth in 3-user Interference channel

wherein \mathbf{v} is an $m \times 1$ vector with entries from \mathbb{F}_p^n and $\alpha_i, \beta_i, \gamma_i \in \mathbb{F}_p, \forall i \in \{1, \dots, l\}$. We will now argue that alignment chain length cannot be extended beyond D . Suppose on the contrary, alignment chain length was greater than D , say $D + 1$. Then without loss of generality, we can choose additional vector at source 3 such that at destination 2, it aligns with the vector $\alpha_l \bar{h}^l \mathbf{v}$ used at source 1. This additional vector at source 3 can be represented as $\gamma_{l+1} \bar{h}^l \mathbf{v}$. Then the vectors sent by source 3 can be represented as

$$\bar{V}_3 = [\gamma_{l+1} \bar{h}^l \mathbf{v} \quad \gamma_l \bar{h}^{l-1} \mathbf{v} \quad \gamma_{l-1} \bar{h}^{l-2} \mathbf{v} \quad \dots \quad \gamma_2 \bar{h} \mathbf{v} \quad \gamma_1 \mathbf{v}] \quad (4.172)$$

Let us consider the signal space at destination 1, $S_1 = [\bar{h}_{11} V_1 \quad V_2 \quad \bar{V}_3]$. Since l vectors from source 3 align with l vectors from source 2, we can denote the signal space as $S_1 = [\bar{h}_{11} V_1 \quad V_2 \quad \gamma_{l+1} \bar{h}^l \mathbf{v}]$. Now we claim that $\bar{h}_{11} V_1$ and V_2 spans the channel space, since all vectors are linearly independent.

$$[\bar{h}_{11} V_1 \quad V_2] = \left[\alpha_l \bar{h}_{11} \bar{h}^l \mathbf{v} \quad \alpha_{l-1} \bar{h}_{11} \bar{h}^{l-1} \mathbf{v} \quad \dots \quad \alpha_1 \bar{h}_{11} \bar{h} \mathbf{v} \quad \bar{h}_{11} \mathbf{v} \quad \beta_l \bar{h}^{l-1} \mathbf{v} \quad \beta_{l-1} \bar{h}^{l-2} \mathbf{v} \quad \dots \quad \beta_2 \bar{h} \mathbf{v} \quad \beta_1 \mathbf{v} \right] \quad (4.173)$$

It can be noted that columns of above matrix are linearly independent when all entries listed below are linearly independent, since V is scaled by different powers of \bar{h} , \bar{h}_{11} and other coefficients.

$$[\alpha_l \bar{h}_{11} \bar{h}^l \quad \alpha_{l-1} \bar{h}_{11} \bar{h}^{l-1} \quad \dots \quad \alpha_1 \bar{h}_{11} \bar{h} \quad \bar{h}_{11} \quad \beta_l \bar{h}^{l-1} \quad \beta_{l-1} \bar{h}^{l-2} \quad \dots \quad \beta_2 \bar{h} \quad \beta_1] \quad (4.174)$$

This is true when following conditions on \bar{h} , \bar{h}_{11} are met.

$$\bar{h}_{11} \notin A \triangleq \left\{ \frac{\alpha_0 + \alpha_1 \bar{h} + \dots + \alpha_{l-1} \bar{h}^{l-1}}{\beta_0 + \beta_1 \bar{h} + \dots + \beta_l \bar{h}^l} : \alpha_k, \beta_m \in \mathbb{F}_p, (\beta_0, \dots, \beta_l) \neq (0, \dots, 0) \right\} \quad (4.175)$$

$$\beta_l \bar{h}^l + \dots + \beta_1 \bar{h} + \beta_0 \neq 0 : \beta_0, \dots, \beta_l \in \mathbb{F}_p, (\beta_0, \dots, \beta_l) \neq (0, \dots, 0) \quad (4.176)$$

Since $n = 2l + 1$ columns of $[\bar{h}_{11} V_1 \quad V_2]$ are linearly independent, additional vector chosen $\gamma_{l+1} \bar{h}^l \mathbf{v}$ must lie in span of $[\bar{h}_{11} V_1 \quad V_2]$. It cannot lie in the space spanned by V_2 because that would contradict (4.168). But if it does not lie in the space spanned by V_2 then the desired signal space $\bar{h}_{11} V_1$ is not resolvable from interference. This is a contradiction, since in the converse we assume that the desired signal is resolvable from interference. Therefore additional vector $\gamma_{l+1} \bar{h}^l \mathbf{v}$ cannot be chosen at source 3 such that it aligns at destination 1, i.e., alignment depth cannot be greater than $D = 3l + 1$. This is illustrated in Fig. 4.11. Similarly alignment chains originating at other sources and ending at other destinations can be shown to be of depth not greater than D . Consolidating the linear independence conditions for all such chains, we note that alignment depth is at most D for channels satisfying conditions ((4.165),(4.166),(4.167),(4.168)). Thus, we have proved Lemma 3.

We now show the outer bound on linear-scheme capacity for 3-user interference channel to be $\frac{3D}{2D+1}$. The proof of this part is almost identical to that in [8] (Theorem 7), so it is summarized only for the sake of completeness.

THEOREM 4.6. *For the 3-user interference channel over \mathbb{F}_{p^n} , outer bound on linear-scheme capacity is given by $\frac{3D}{2D+1}$, with $D = 2n - \lfloor \frac{n}{2} \rfloor - 1$ for odd $n = 2l + 1$ wherein channels satisfy the*

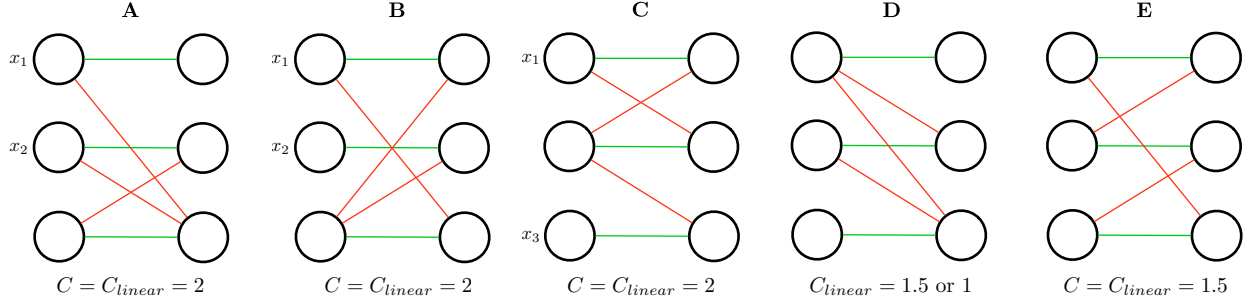

Figure 4.12: Distinct channel structures with 3 cross channels as 0

following conditions

$$\bar{h}_{11} \notin A \triangleq \left\{ \frac{\alpha_0 + \alpha_1 \bar{h} + \dots + \alpha_{l-1} \bar{h}^{l-1}}{\beta_0 + \beta_1 \bar{h} + \dots + \beta_l \bar{h}^l} : \alpha_k, \beta_m \in \mathbb{F}_p, (\beta_0, \dots, \beta_l) \neq (0, \dots, 0) \right\} \quad (4.177)$$

$$\bar{h}_{22} \notin B \triangleq \left\{ \frac{\alpha_0 + \alpha_1 \bar{h} + \dots + \alpha_l \bar{h}^l}{\beta_0 + \beta_1 \bar{h} + \dots + \beta_{l-1} \bar{h}^{l-1}} : \alpha_k, \beta_m \in \mathbb{F}_p, (\beta_0, \dots, \beta_{l-1}) \neq (0, \dots, 0) \right\} \quad (4.178)$$

$$\bar{h}_{33} \notin C \triangleq \left\{ \frac{\alpha_0 + \alpha_1 \bar{h} + \dots + \alpha_l \bar{h}^l}{\beta_0 + \beta_1 \bar{h} + \dots + \beta_{l-1} \bar{h}^{l-1}} : \alpha_k, \beta_m \in \mathbb{F}_p, (\beta_0, \dots, \beta_{l-1}) \neq (0, \dots, 0) \right\} \quad (4.179)$$

$$\beta_l \bar{h}^l + \dots + \beta_1 \bar{h} + \beta_0 \neq 0 : \beta_0, \dots, \beta_l \in \mathbb{F}_p, (\beta_0, \dots, \beta_l) \neq (0, \dots, 0) \quad (4.180)$$

Proof: Let $V_{i\uparrow k}$ denote the signal space of user i (part of V_i) aligned to depth $k+1$ and $d_i = \dim(V_i)$, $d_{i\uparrow k} = \dim(V_{i\uparrow k})$. Lemma 8 of [8] follows since we have finite dimensional subspaces, i.e., $d_{i\uparrow k} \geq d_{i\uparrow k+a} + d_{i-b\uparrow k+b} - d_{i-b\uparrow k+a+b}$. For $a = -1, b = -1$, we have

$$d_{i\uparrow k} \geq d_{i\uparrow k-1} + d_{i+1\uparrow k-1} - d_{i+1\uparrow k-2} \quad (4.181)$$

Since alignment depth is at most D (Lemma 3), $V_{i\uparrow D} = \{0\}$ for each i , and so similar to lemma 9 of [8], we have

$$d_i \geq d_{i-1\uparrow 1} + d_{i\uparrow D-1} \quad (4.182)$$

Let us denote $c_k = \sum_{i=1}^3 d_{i \uparrow k}$. Then using 4.181, we have $c_k \geq 2c_{k-1} - c_{k-2}$. Using induction, it can be deduced that $c_k \geq ic_{k-i+1} - (i-1)c_{k-i}$. For $i = k = D - 1$, we have

$$(D - 2)c_0 \geq (D - 1)c_1 - c_{D-1} \quad (4.183)$$

Using 4.182, it can be shown that $c_0 \geq c_1 + c_{D-1}$. Combining with 4.183, we have $(D-1)c_0 \geq Dc_1$. Let total dimension at each destination be denoted by $N = mn$ where m symbol extensions of the channel is considered with channels from \mathbb{F}_{p^n} . Since interference span must be linearly independent of desired signal, and considering N dimensions at destination 1, we have

$$\text{Destination 1: } \dim(\bar{h}_{11}V_1 + V_2 + V_3) = d_1 + d_2 + d_3 - d_{2 \uparrow 1} \leq N$$

$$\text{Destination 2: } \dim(V_1 + \bar{h}_{22}V_2 + V_3) = d_1 + d_2 + d_3 - d_{3 \uparrow 1} \leq N$$

$$\text{Destination 3: } \dim(V_1 + \bar{h}V_2 + \bar{h}_{33}V_3) = d_1 + d_2 + d_3 - d_{1 \uparrow 1} \leq N$$

Adding above inequalities and using $(D - 1)c_0 \geq Dc_1$, we can deduce as in [8] that

$$\frac{d_1 + d_2 + d_3}{N} \leq \frac{3D}{2D + 1} \quad (4.184)$$

Thus we have proved the outer bound on linear-scheme capacity for 3-user interference channel over \mathbb{F}_{p^n} with channels satisfying aforementioned linear independence constraints.

4.4 Summary

Capacity and linear capacity results are explored for the 2-user X channel and the 3-user interference channel respectively, over the finite field \mathbb{F}_{p^n} , by translating precoding based interference alignment schemes from corresponding DoF results for the wireless setting. The main insight is that the finite field \mathbb{F}_{p^n} can be viewed as analogous to diagonal $n \times n$ wireless channels with di-

diversity n . This insight appears to be broadly true for linear precoding based schemes. While the linear capacity is fully characterized, the information theoretic capacity remains open for finite field networks over \mathbb{F}_p , i.e., for $n = 1$, where diversity is only 1. We expect that signal level alignment schemes and combinatorial outer bound arguments such as those presented in [17] should be useful in these cases.

Chapter 5

Conclusions

Three categories were studied to understand the impact of non-generic channels on the signaling dimensions of linear communication networks.

Implications of rank deficiencies on the DoF of MIMO interference networks were explored, involving either asymptotic or non-asymptotic interference alignment schemes. One of the key observations is that the rank deficiencies of the cross channels cannot hurt and could even improve the DoF, while the rank deficiencies of the direct channels cannot help and could hurt. For the K -user interference channel with $M \times M$ channels being rank deficient, DoF per user was found to be $\min\left(D_0, M - \frac{\min(M, (K-1)D)}{2}\right)$ where D_0 is the rank of all direct channels, and D is the rank of all cross channels.

The single user MIMO rank deficient channel with full decomposition (no joint processing) is same as the problem with the overall transfer matrix of a SISO interference channel being rank deficient. In a K -user SISO interference channel, the overall $K \times K$ transfer matrix could be rank deficient, say rank D . This could arise because of network topology, wherein relays with D antennas listen to signals from K transmitters and forward to K receivers. Study of alignment feasibility for a multiple unicast session with similar network topology is one relevant problem, as in [37] for 3

users, highlighting the significance of rank deficiencies in wired networks. However, feasibility problem is open for interference channel with $K > 3$ users, and is an interesting research avenue. Some of our findings were presented in [44].

2-hop rank deficient interference channel was studied to understand multi-hop network dependencies along with rank deficient channels. For the 2-hop rank deficient interference channel, a rank matching principle was identified similar to impedance matching, wherein maximum of $2M$ DoF are achieved when the ranks in both hops are the same. Under moderate rank deficiencies, the DoF loss was found to be the rank mismatch between the 2 hops. For the 2-hop rank deficient interference channel with M antennas at all nodes, DoF was found to be $\min(4D_1, 4D_2, 2M - \Delta D)$, wherein $\Delta D = |D_1 - D_2|$ and D_1 is the rank of all channels in the first hop and D_2 is the rank of all channels in the second hop. Further in [52], to understand the implications of the rank-matching bounds beyond the sum-DoF of the 2-hop interference channel, limited extensions were studied — beyond sum-DoF to DoF regions, beyond 2 unicasts to general message sets (X setting), beyond 2 hops to the $2 \times 2 \times 2 \times 2$ setting and beyond 2 nodes per layer to the $K \times K \times K$ setting. In particular, we find that the DoF loss due to rank-mismatch may be circumvented, at least in symmetric settings, through expanded message sets and/or expanded number of hops.

Constant finite field channels over \mathbb{F}_{p^n} were studied to understand the limitations of finite alphabet with limited diversity. Scalar (SISO) channels over \mathbb{F}_{p^n} are equivalent to vector $n \times n$ MIMO channels over \mathbb{F}_p . Through the study of the capacity of 2-user finite field X channel and linear-scheme capacity of 3-user finite field interference channel, interesting parallels were drawn between p and SNR, and n and channel diversity.

Bibliography

- [1] S. -W. Jeon, S. -Y. Chung, and S. Jafar. Degrees of freedom region of a class of multisource gaussian relay networks. *IEEE Trans. on Information Theory*, 57:3032–3044, May 2011.
- [2] A. Agustin and J. Vidal. Degrees of freedom region of the MIMO X channel with an arbitrary number of antennas. *Arxiv preprint ArXiv:1210.2582*, October 2012.
- [3] T. D. Bavorisetti, G. Abhinav, K. Prasad, and B. S. Rajan. A transform approach to linear network coding for acyclic networks with delay. *CoRR*, abs/1103.3882, 2011.
- [4] Y. Birk and T. Kol. Informed-source coding-on-demand (ISCOD) over broadcast channels. In *Proceedings of the Seventeenth Annual Joint Conference of the IEEE Computer and Communications Societies, IEEE INFOCOM'98*, volume 3, pages 1257–1264, 1998.
- [5] G. Bresler, D. Cartwright, and D. Tse. Geometry of the 3-user MIMO interference channel. *Arxiv preprint ArXiv:1110.5092*, October 2011.
- [6] G. Bresler, D. Cartwright, and D. Tse. Geometry of the 3-user mimo interference channel. *ArXiv*, abs/1110.5092, 2011.
- [7] G. Bresler, D. Cartwright, and D. Tse. Settling the feasibility of interference alignment for the MIMO interference channel: the symmetric square case. *CoRR*, abs/1104.0888, 2011.
- [8] G. Bresler and D. Tse. 3 User interference channel: Degrees of freedom as a function of channel diversity. In *47th Annual Allerton Conference on Communication, Control, and Computing*, pages 265–271, 2009.
- [9] V. Cadambe and S. Jafar. Interference alignment and the degrees of freedom of the K user interference channel. *IEEE Transactions on Information Theory*, 54(8):3425–3441, Aug. 2008.
- [10] V. Cadambe and S. Jafar. Interference alignment and the degrees of freedom of wireless X networks. *IEEE Trans. on Information Theory*, (9):3893–3908, Sep 2009.
- [11] V. Cadambe and S. Jafar. Parallel Gaussian interference channels are not always separable. *IEEE Transactions on Information Theory*, 55(9):3983–3990, 2009.
- [12] V. Cadambe, S. Jafar, and C. Wang. Interference Alignment With Asymmetric Complex Signaling Settling the Høst-Madsen–Nosratinia Conjecture. *IEEE Transactions on Information Theory*, 56(9):4552–4565, 2010.

- [13] V. Cadambe, S. A. Jafar, H. Maleki, K. Ramchandran, and C. Suh. Asymptotic interference alignment for optimal repair of mds codes in distributed storage. *IEEE Trans. on Information Theory*, 59(5):2974–4987, May 2013.
- [14] V. R. Cadambe and S. A. Jafar. Degrees of freedom of wireless networks with relays, feedback, cooperation and full duplex operation. *IEEE Transactions on Information Theory*, 55:2334–2344, May 2009.
- [15] S. H. Chae and S.-Y. Chung. On the degrees of freedom of rank deficient interference channels. In *2011 IEEE International Symposium on Information Theory Proceedings (ISIT)*, pages 1367–1371, 2011.
- [16] A. K. Das, S. Vishwanath, S. A. Jafar, and A. Markopoulou. Network coding for multiple unicasts: An interference alignment approach. *CoRR*, abs/1008.0235, 2010.
- [17] R. Etkin and E. Ordentlich. The degrees-of-freedom of the K-User Gaussian interference channel is discontinuous at rational channel coefficients. *IEEE Trans. on Information Theory*, 55:4932–4946, Nov. 2009.
- [18] A. Ghasemi, A. Motahari, and A. Khandani. Interference alignment for the K user MIMO interference channel. In *Proceedings of International Symposium on Information Theory (ISIT)*, pages 360–364. IEEE, 2010.
- [19] K. Gomadam, V. Cadambe, and S. Jafar. A distributed numerical approach to interference alignment and applications to wireless interference networks. *IEEE Trans. on Information Theory*, pages 3309–3322, June 2011.
- [20] O. Gonzalez, C. Beltrn, and I. Santamaria. On the feasibility of interference alignment for the k-user mimo channel with constant coefcients. *ArXiv*, abs/1202.0186, 2012.
- [21] T. Gou and S. Jafar. Degrees of freedom of the K user $M \times N$ MIMO interference channel. *IEEE Trans. on Information Theory*, 56(12):6040–6057, December 2010.
- [22] T. Gou, C. Wang, S. Jafar, S. Jeon, and S. Chung. Aligned interference neutralization and the degrees of freedom of the $2 \times 2 \times 2$ interference channel. *IEEE Trans. on Information Theory*, 58(7):4381–4395, July 2012.
- [23] T. Gou, C. Wang, and S. A. Jafar. Degrees of freedom of a class of non-layered two unicast wireless network. In *Asilomar Conference on Signals, Systems and Computers*, Nov. 2011.
- [24] S.-N. Hong and G. Caire. On interference networks over finite fields. *CoRR*, abs/1308.0870, 2013.
- [25] C. Huang, V. Cadambe, and S. Jafar. Interference alignment and the generalized degrees of freedom of the X channel. *IEEE Transactions on Information Theory*, 58(8):5130–5150, August 2012.
- [26] S. Jafar. Interference alignment: A new look at signal dimensions in a communication network. In *Foundations and Trends in Communication and Information Theory*, pages 1–136, 2011.

- [27] S. Jafar and M. Fakhreddin. Degrees of freedom for the MIMO interference channel. *IEEE Transactions on Information Theory*, 53(7):2637–2642, July 2007.
- [28] S. Jafar and S. Shamai. Degrees of freedom region for the MIMO X channel. *IEEE Trans. on Information Theory*, 54(1):151–170, Jan. 2008.
- [29] S. A. Jafar. Blind Interference Alignment. *IEEE Journal of Selected Topics in Signal Processing*, 6(3):216–227, June 2012.
- [30] S. A. Jafar. Topological Interference Management through Index Coding. *IEEE Trans. on Information Theory*, 60(1):529–568, Jan. 2014.
- [31] L. Ke, A. Ramamoorthy, Z. Wang, and H. Yin. Degrees of freedom region for an interference network with general message demands. *IEEE Transactions on Information Theory*, 58(6):3787–3797, June 2012.
- [32] S. Krishnamurthy, A. Ramakrishnan, and S. Jafar. Degrees of freedom of rank-deficient mimo interference networks. *submitted to IEEE Transactions on Information Theory*.
- [33] S. Krishnamurthy and S. Jafar. ”degrees of freedom of 2-user and 3-user rank-deficient mimo interference channels”. In *Global Communications Conference (GLOBECOM), 2012 IEEE*, pages 2462–2467, Dec 2012.
- [34] S. Krishnamurthy and S. Jafar. On the capacity of the finite field counterparts of wireless interference networks. *IEEE Transactions on Information Theory*, 60(7):4101 – 4124, July 2014.
- [35] M. Maddah-Ali, A. Motahari, and A. Khandani. Communication over MIMO X channels: Interference alignment, decomposition, and performance analysis. In *IEEE Trans. on Information Theory*, pages 3457–3470, August 2008.
- [36] H. Maleki, V. Cadambe, and S. Jafar. Index coding – an interference alignment perspective. *ISIT 2012, Preprint of Full Paper available at ArXiv:1205.1483*, 2012.
- [37] C. Meng, A. K. Das, A. Ramakrishnan, S. A. Jafar, A. Markopoulou, and S. Vishwanath. Precoding-based network alignment for three unicast sessions. *CoRR*, abs/1305.0868, 2013.
- [38] C. Meng, A. Ramakrishnan, A. Markopoulou, and S. A. Jafar. On the feasibility of precoding-based network alignment for three unicast sessions. In *Proceedings of IEEE International Symposium on Information Theory (ISIT), 2012*, pages 1907–1911. IEEE, 2012.
- [39] S. Mohajer, S. Diggavi, C. Fragouli, and D. Tse. Approximate Capacity of a Class of Gaussian Interference-Relay Networks. *IEEE Trans. on Information Theory*, 57:2837–2864, May 2011.
- [40] A. Motahari, S. Gharan, M. Maddah-Ali, and A. Khandani. Real interference alignment: Exploiting the potential of single antenna systems. *CoRR*, abs/0908.2282, 2009.
- [41] B. Nazer, M. Gastpar, S. Jafar, and S. Vishwanath. Ergodic interference alignment. *IEEE Trans. on Information Theory*, 58(10):6355–6371, Oct. 2012.

- [42] U. Niesen and M. A. Maddah-Ali. Interference alignment: From degrees-of-freedom to constant-gap capacity approximations. *CoRR*, abs/1112.4879, 2011.
- [43] A. Ramakrishnan, A. Das, H. Maleki, A. Markopoulou, S. Jafar, and S. Vishwanath. Network Coding for Three Unicast Sessions: Interference Alignment Approaches. *Allerton Conference on Communications, Control and Computing*, October 2010.
- [44] A. Ramakrishnan, S. R. Krishnamurthy, S. A. Jafar, and Y. Yu. Degrees of freedom of interference channel with rank-deficient transfer matrix. In *Proceedings of IEEE International Symposium on Information Theory (ISIT), 2014*, Jul. 2014.
- [45] M. Razaviyayn, G. Lyubeznik, and Z. Luo. On the degrees of freedom achievable through interference alignment in a MIMO interference channel. *CoRR*, abs/1104.0992, 2011.
- [46] L. Ruan, V. K. Lau, and M. Z. Win. The feasibility conditions for interference alignment in mimo networks. *ArXiv*, abs/1211.3484v1, 2012.
- [47] J. T. Schwartz. Fast probabilistic algorithms for verification of polynomial identities. *Journal of the Association for Computing Machinery*, 27(4):701–717, Oct. 1980.
- [48] I. Shomorony and A. S. Avestimehr. Degrees of freedom of two-hop wireless networks: "everyone gets the entire cake". *CoRR*, abs/1210.2143, 2012.
- [49] I. Shomorony and S. Avestimehr. Two-unicast wireless networks: Characterizing the sum degrees of freedom. *IEEE Transactions on Information Theory*, 59(1):353–383, 2013.
- [50] G. Sridharan and W. Yu. Degrees of freedom of mimo cellular networks: Decomposition and linear beamforming design. *CoRR*, abs/1312.2681, 2013.
- [51] H. Sun, C. Geng, and S. Jafar. Degrees of freedom of MIMO X networks: Spatial scale invariance, one-sided decomposability and linear feasibility. *Arxiv preprint ArXiv:11207.6137*, July 2012.
- [52] H. Sun, S. R. Krishnamurthy, and S. A. Jafar. Rank-matching for multi-hop multi-flow. *CoRR*, abs/1405.0724, 2014.
- [53] V. Annapureddy and A. El Gamal and V. Veeravalli. Degrees of Freedom of Interference Channels With CoMP Transmission and Reception. *IEEE Trans. on Information Theory*, 58(9):5740–5760, Sep. 2012.
- [54] C. Wang, T. Gou, and S. Jafar. Multiple unicast capacity of 2-source 2-sink networks. *CoRR*, abs/1104.0954, 2011.
- [55] C. Wang, T. Gou, and S. Jafar. Subspace alignment chains and the degrees of freedom of the three user MIMO interference channel. *IEEE Transactions on Information Theory*, To appear 2014.
- [56] C. Wang, S. Jafar, S. Shamai, and M. Wigger. Interference, cooperation and connectivity - a degrees of freedom perspective. *Presented in part at ISIT 2011*, abs/1103.6060, 2011.

- [57] C. Wang and A. Sezgin. Degrees of freedom of the interference channel with a cognitive helper. *IEEE Communication Letters*, 17(5):920–923, May 2013.
- [58] C. Wang, H. Sun, and S. Jafar. Genie chains and the Degrees of Freedom of the K-user MIMO Interference Channel. In *Proceedings of International Symposium on Information Theory (ISIT)*. IEEE, 2012.
- [59] Z. Wang. Real interference alignment and degrees of freedom region of wireless X networks. In *International Symposium on Wireless Communication Systems*, 2011.
- [60] C. Yetis, T. Gou, S. Jafar, and A. Kayran. On feasibility of interference alignment in MIMO interference networks. *IEEE Transactions on Signal Processing*, 58(9):4771–4782, 2010.
- [61] M. Zamanighomi and Z. Wang. Multiple-antenna interference channel with receive antenna joint processing and real interference alignment. *Proceedings of ISIT 2013*, July 2013.
- [62] Y. Zeng, X. Xu, Y. L. Guan, and E. Gunawan. On the achievable degrees of freedom for the 3-user rank-deficient mimo interference channel. *CoRR*, abs/1211.4198, 2012.
- [63] R. Zippel. Probabilistic algorithms for sparse polynomials. In *Proceedings of the International Symposium on Symbolic and Algebraic Computation*, EUROSAM '79, pages 216–226, 1979.

Appendix A

Constant finite field channels : Proofs

A.1 Zero Channels in 3-user Interference channel

Here, we deal with realizations of the 3-user interference channel where some of the channel coefficients are zero.

THEOREM A.1. *For the 3 user interference channel over \mathbb{F}_{p^n} , if one or more of the channel coefficients h_{ji} is equal to zero, the capacity results are given as follows:*

1. *If all three direct channels are zero, then $C = C_{linear} = 0$.*
2. *If any two direct channels are zero, then $C = C_{linear} = 1$.*
3. *If exactly one direct channel is zero, then $C = C_{linear} = 1$ or $C = C_{linear} = 2$, depending on whether any of the cross-channels between the other two users takes a non-zero value or they are all zero, respectively.*
4. *If all direct channels are non-zero and all 6 cross channels are zero, then $C = C_{linear} = 3$.*

5. If all direct channels are non-zero and either 4 or 5 cross channels are zero, then $C = C_{linear} = 2$.
6. If all direct channels are non-zero and either 2 or 3 cross channels are zero, and if $h_{ij} = h_{ji} = 0$ for any one $\{i, j\} \in \{1, 2, 3\}$, then $C = C_{linear} = 2$.
7. In all other cases, the linear capacity is either 1 or 1.5 for channels over \mathbb{F}_{p^n} with $p > 3$ (the specific cases for each are identified in the proof).

Proof: Cases 1, 2, 3, 4, 6 are trivial. The remaining cases are discussed below.

Case 5: For all these channel structures, it can be shown that there always exists at least one $\{i, j\} \in \{1, 2, 3\}$ such that $h_{ij} = h_{ji} = 0$, and so only the sources $\{i, j\}$ can be used for transmission, leading to a sum rate of 2 being achievable. Outer bound of 2 follows by removing all but one non-zero cross-link.

Case 7:

For the achievability of sum rate of 1.5, consider the following:

1. All channels are from \mathbb{F}_{p^n} . For even $n = 2l$, we choose beamforming matrices $V \in \mathbb{F}_{p^n}^{1 \times l}$ at some of the sources and $V' \in \mathbb{F}_{p^n}^{1 \times l}$ at others, and precode $\frac{n}{2} = l$ symbols $x_k^1, x_k^2, \dots, x_k^l \in \mathbb{F}_p$ for each channel use, at all 3 sources. We denote the l columns of V as $\mathbf{v}_1, \mathbf{v}_2, \dots, \mathbf{v}_l$ and those of V' as $\mathbf{v}'_1, \mathbf{v}'_2, \dots, \mathbf{v}'_l$. These beam forming matrices would be chosen such that desired and interference symbols are linearly independent over \mathbb{F}_p at the destinations.
2. When n is odd, 2 symbol extensions are used wherein the beamforming matrix $V \in \mathbb{F}_{p^n}^{2 \times n}$ is used at some of the sources and $V' \in \mathbb{F}_{p^n}^{2 \times n}$ at others. Over 2 channel uses, n input symbols are precoded at each source. Columns of V and V' are then chosen such that desired and interference symbols are linearly independent over \mathbb{F}_p at all destinations. Linear independence arguments follow similar to case of even n .

We describe only even n for various channel structures, for brevity. Let us first consider the setting where 3 cross channels are zero. There are 5 distinct channel structures corresponding to any three cross channels being zero, and all other channel structures ($\binom{6}{3} - 5 = 15$) are isomorphic to them. These 5 channel structures are shown in Fig. 4.12. Of these, A, B, C belong to Case 5, and are therefore trivial.

Structure D:

For this structure, interference from sources 1 and 2 need to be aligned at destination 3. The normalized channel for this structure is illustrated in Fig. A.1.

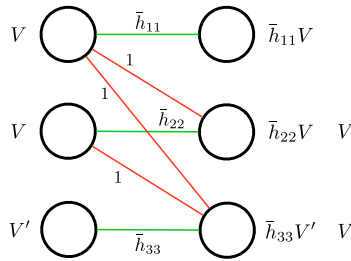

Figure A.1: Normalized channel of structure D

Beam forming matrix V is used at sources 1 and 2, and V' is used at source 3. Signal spaces at 3 destinations are then given by

$$S_1 = [\bar{h}_{11}V] = [\bar{h}_{11}\mathbf{v}_1, \bar{h}_{11}\mathbf{v}_2, \dots, \bar{h}_{11}\mathbf{v}_l] \tag{A.1}$$

$$S_2 = [\bar{h}_{22}V \quad V] = [\bar{h}_{22}\mathbf{v}_1, \bar{h}_{22}\mathbf{v}_2, \dots, \bar{h}_{22}\mathbf{v}_l, \mathbf{v}_1, \mathbf{v}_2, \dots, \mathbf{v}_l] \tag{A.2}$$

$$S_3 = [\bar{h}_{33}V' \quad V] = [\bar{h}_{33}\mathbf{v}'_1, \bar{h}_{33}\mathbf{v}'_2, \dots, \bar{h}_{33}\mathbf{v}'_l, \mathbf{v}_1, \mathbf{v}_2, \dots, \mathbf{v}_l] \tag{A.3}$$

Consider signal space at destination 2. Let us choose \mathbf{v}_1 as 1, then if $\bar{h}_{22} \notin \mathbb{F}_p$, $[\bar{h}_{22}\mathbf{v}_1 \quad \mathbf{v}_1]$ are linearly independent over \mathbb{F}_p . Now let us construct \mathbf{v}_2 such that 4 columns of S_2 , $[\bar{h}_{22}\mathbf{v}_1 \quad \mathbf{v}_1 \quad \bar{h}_{22}\mathbf{v}_2 \quad \mathbf{v}_2]$

are linearly independent over \mathbb{F}_p .

$$\text{From } S_2, \quad \mathbf{v}_2 \notin A \triangleq \left\{ \frac{(\alpha_1 \bar{h}_{22} + \alpha_2) \mathbf{v}_1}{\beta_1 \bar{h}_{22} + \beta_2} : \alpha_1, \alpha_2, \beta_1, \beta_2 \in \mathbb{F}_p, (\beta_1, \beta_2) \neq (0, 0) \right\} \quad (\text{A.4})$$

Now we note that

$$|A| \leq \frac{(p^2 - 1)p^2}{p - 1} = p^3 + p^2 \quad (\text{A.5})$$

There are p^n choices for \mathbf{v}_2 , and since $p^n > (p^3 + p^2)$ for all p , there exist choices for \mathbf{v}_2 such that condition (A.4) holds. Choosing \mathbf{v}_2 from those, we note that 4 columns of S_2 are linearly independent over \mathbb{F}_p . We proceed recursively in a similar manner, for choosing columns $\mathbf{v}_3, \mathbf{v}_4, \dots, \mathbf{v}_{l-1}$ such that $6, 8, \dots, 2(l-1)$ columns are linearly independent over \mathbb{F}_p respectively, in S_2 .

Let us now discuss the last iteration wherein we choose column \mathbf{v}_l such that all $n = 2l$ columns are linearly independent over \mathbb{F}_p in S_2 , given that $2l - 2$ columns are already linearly independent with appropriate choices of $\mathbf{v}_1, \mathbf{v}_2, \dots, \mathbf{v}_{l-1}$.

$$\text{From } S_2, \quad \mathbf{v}_l \notin A \triangleq \left\{ \frac{1}{\beta_1 \bar{h}_{22} + \beta_2} ((\alpha_1 \bar{h}_{22} + \alpha_2) \mathbf{v}_1 + (\alpha_3 \bar{h}_{22} + \alpha_4) \mathbf{v}_2 + \dots + (\alpha_{2l-3} \bar{h}_{22} + \alpha_{2l-2}) \mathbf{v}_{l-1}) : \alpha_i, \beta_1, \beta_2 \in \mathbb{F}_p, i \in \{1, \dots, 2l-2\}, (\beta_1, \beta_2) \neq (0, 0) \right\} \quad (\text{A.6})$$

Now we note that

$$|A| \leq \frac{(p^2 - 1)p^{2l-2}}{p - 1} = p^{2l-1} + p^{2l-2} \quad (\text{A.7})$$

There are $p^n = p^{2l}$ choices for \mathbf{v}_l , and since $p^{2l} > (p^{2l-1} + p^{2l-2})$ for all p , there exist choices for \mathbf{v}_l such that condition (A.6) holds. Choosing \mathbf{v}_l from those, we note that all n columns of S_2 are linearly independent over \mathbb{F}_p . Also, it can be noted that $l = \frac{n}{2}$ columns of V in S_1 and S_3 are linearly independent over \mathbb{F}_p . Destination 1 does not receive any interference and so desired

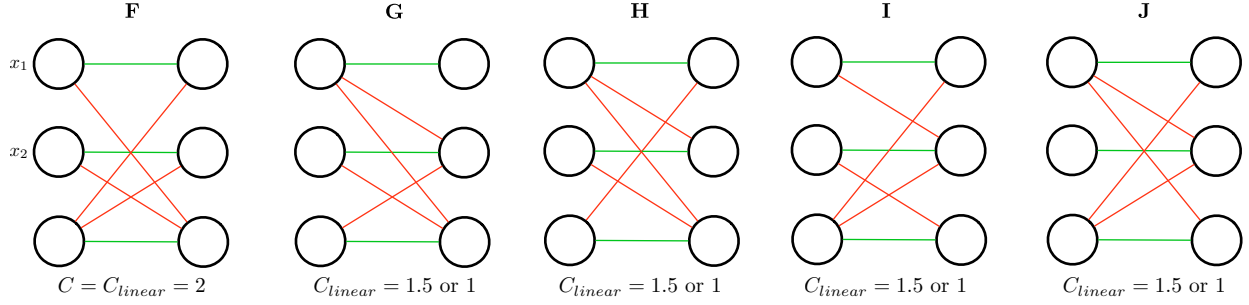

Figure A.2: Distinct channel structures with 2 cross channels as 0

symbols are resolvable.

Let us now consider destination 3 where interference is aligned in $\frac{n}{2} = l$ linearly independent columns of V . Since source 3 does not cause interference anywhere, V' is trivially chosen to be $\frac{1}{h_{33}}$ times the remaining $n/2$ basis vectors. Hence, desired and interference symbols are linearly independent at all destinations. Thus, sum rate of $\frac{3}{2}$ is achieved for structure D in Fig. A.1, with channels over \mathbb{F}_p for all even n , if $\bar{h}_{22} \notin \mathbb{F}_p$.

Fraction of channels for which scheme achieves $\frac{3}{2}$ sum rate is given by

$$\frac{p^n - p}{p^n} = 1 - \frac{1}{p^{n-1}} \rightarrow 1 \text{ for large } p, n \quad (\text{A.8})$$

$\frac{3}{2}$ is also an information theoretic outer bound on sum rate for structure D because the sum-rate of any two users is bounded by 1. However, when $\bar{h}_{22} = 1$, then arguing along the lines of [11] we find that destination 3 can decode all three messages, so that the information theoretic sum-capacity bound = 1. For all other cases where $\bar{h}_{22} \in \mathbb{F}_p$ but $\bar{h}_{22} \notin \{0, 1\}$, the linear capacity is still 1 (because the linear capacity does not depend on the scaling of channel coefficients by non-zero \mathbb{F}_p elements) but the information theoretic capacity is unknown.

Thus, structure D has linear capacity of 1.5 if $\bar{h}_{22} \notin \mathbb{F}_p$, and 1 otherwise.

Structure E: For structure E, the sum rate of 1.5 is achieved even without channel knowledge at the sources. For example, source 1 sends an \mathbb{F}_p symbol only over the first channel use and stays quiet over the second channel use, source 2 sends a \mathbb{F}_p symbol over the second channel use and

remains quiet over the first channel use, and source 3 repeats its \mathbb{F}_p^n symbol over both channel uses. This allows each destination to decode its desired symbols. The outer bound of 1.5 applies because the sum-capacity of any two users is 1. Thus, structure E has $C = C_{linear} = 1.5$.

Next let us consider cases where 2 cross channels are 0, shown in Fig. A.2. Structure F belongs to Case 5, so it is trivial.

Structure G: The normalized channel for this structure is illustrated in Fig. A.3. For this structure, signals from sources 1 and 2 need to be aligned at destination 3 and remain resolvable at destination 2. Following the proof for structure *D*, this can be done if $\bar{h}_{22} \notin \mathbb{F}_p$. Similarly, signals from sources 1 and 3 need to align at destination 2 and remain resolvable at destination 3. This can be done if $\bar{h}_{33} \notin \mathbb{F}_p$. We choose V such that both $S_2 = [\bar{h}_{22}V \ V]$ and $S_3 = [\bar{h}_{33}V \ V]$ are linearly independent over \mathbb{F}_p , which can be shown to be possible for all $p > 2$. Thus, sum rate of $\frac{3}{2}$ is achieved for structure G in Fig. A.3, with channels over \mathbb{F}_p^n for all even n , if $\bar{h}_{22}, \bar{h}_{33} \notin \mathbb{F}_p$. The outer bound of $\frac{3}{2}$ follows from the pair-wise bounds. If all non-zero channels are equal to 1, then the argument of [11] shows that one destination can decode all messages, i.e., $C = C_{linear} = 1$. In all other cases with non-zero $\bar{h}_{kk} \in \mathbb{F}_p$ for any $k = 2, 3$, the linear capacity is still one because the linear capacity is not affected by a scaling of channel coefficients by non-zero constants in \mathbb{F}_p . Thus structure G has linear-scheme capacity of $\frac{3}{2}$ if $\bar{h}_{kk} \notin \mathbb{F}_p, k \in \{2, 3\}$, and 1 otherwise.

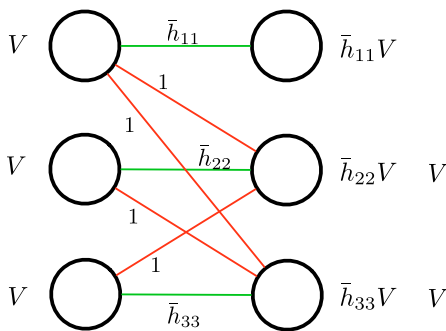

Figure A.3: Normalized channel - structure G

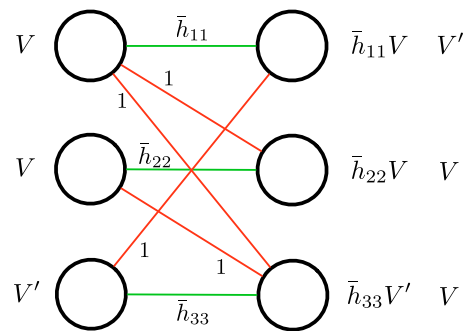

Figure A.4: Normalized channel - structure H

Structure H:

The normalized channel for this structure is illustrated in Fig. A.4. For this structure, signals from sources 1 and 2 need to be aligned at destination 3 and remain resolvable at destination 2. Following the proof for structure *D*, this can be done if $\bar{h}_{22} \notin \mathbb{F}_p$. We choose V' such that both $S_1 = [\bar{h}_{11}V \ V']$ and $S_3 = [\bar{h}_{33}V' \ V]$ are linearly independent over \mathbb{F}_p , which can be shown to be possible for all $p > 2$. Thus, sum rate of $\frac{3}{2}$ is achieved for structure H in Fig. A.4, with channels over \mathbb{F}_{p^n} for all even n , if $\bar{h}_{22} \notin \mathbb{F}_p$. The outer bound of $\frac{3}{2}$ follows from the pair-wise bounds. If all non-zero channels are equal to 1, then the argument of [11] shows that one destination can decode all messages, i.e., $C = C_{linear} = 1$. In all other cases with non-zero $\bar{h}_{22} \in \mathbb{F}_p$, the linear capacity is still one because the linear capacity is not affected by a scaling of channel coefficients by non-zero constants in \mathbb{F}_p . Thus structure H has linear-scheme capacity of $\frac{3}{2}$ if $\bar{h}_{22} \notin \mathbb{F}_p$, and 1 otherwise.

Structure I:

The normalized channel for this structure is illustrated in Fig. A.5. For this structure, signals from sources 1 and 3 need to be aligned at destination 2 and remain resolvable at destination 1. Following the proof for structure *D*, this can be done if $\bar{h}_{11} \notin \mathbb{F}_p$. We choose V' such that both $S_2 = [\bar{h}_{22}V' \ V]$ and $S_3 = [\bar{h}_{33}V \ V']$ are linearly independent over \mathbb{F}_p , which can be shown to be possible for all $p > 2$. Thus, sum rate of $\frac{3}{2}$ is achieved for structure H in Fig. A.5, with channels over \mathbb{F}_{p^n} for all even n , if $\bar{h}_{11} \notin \mathbb{F}_p$. The outer bound of $\frac{3}{2}$ follows from the pair-wise bounds. If all non-zero channels are equal to 1, then the argument of [11] shows that one destination can decode all messages, i.e., $C = C_{linear} = 1$. In all other cases with non-zero $\bar{h}_{11} \in \mathbb{F}_p$, the linear capacity is still one because the linear capacity is not affected by a scaling of channel coefficients by non-zero constants in \mathbb{F}_p . Thus structure I has linear-scheme capacity of $\frac{3}{2}$ if $\bar{h}_{11} \notin \mathbb{F}_p$, and 1 otherwise.

Structure J:

The normalized channel for this structure is illustrated in Fig. A.6. For this structure, signals from sources 1 and 3 need to be aligned at destination 2 but remain resolvable at destinations 1 and 3. Following the proof for structure *D*, this can be done if $\bar{h}_{11}, \bar{h}_{33} \notin \mathbb{F}_p$. We choose V such that both $S_1 = [\bar{h}_{11}V \ V]$ and $S_3 = [\bar{h}_{33}V \ V]$ are linearly independent over \mathbb{F}_p , which can be shown to be

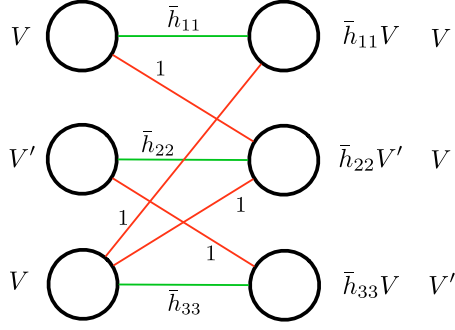

Figure A.5: Normalized channel - structure I

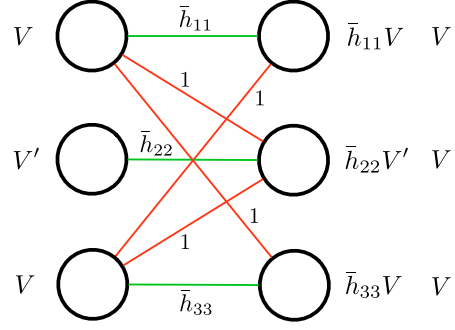

Figure A.6: Normalized channel - structure J

possible for all $p > 2$. Thus, sum rate of $\frac{3}{2}$ is achieved for structure J in Fig. A.6, with channels over \mathbb{F}_{p^n} for all even n , if $\bar{h}_{11}, \bar{h}_{33} \notin \mathbb{F}_p$. The outer bound of $\frac{3}{2}$ follows from the pair-wise bounds. If all non-zero channels are equal to 1, then the argument of [11] shows that one destination can decode all messages, i.e., $C = C_{linear} = 1$. In all other cases with non-zero $\bar{h}_{kk} \in \mathbb{F}_p$ for any $k = 1, 3$, the linear capacity is still one because the linear capacity is not affected by a scaling of channel coefficients by non-zero constants in \mathbb{F}_p . Thus structure J has linear-scheme capacity of $\frac{3}{2}$ if $\bar{h}_{kk} \notin \mathbb{F}_p, k \in \{1, 3\}$, and 1 otherwise.

Finally, let us now consider the setting where only one cross channel is zero.

Structure K:

The normalized channel for this structure is illustrated in Fig. A.7. For this single channel structure, interference from sources 2 and 3 need to be aligned at destination 1, and interference from sources 1 and 3 need to be aligned at destination 2.

Beam forming matrix V is used at all 3 sources. Signal spaces at 3 destinations are then given by

$$S_1 = [\bar{h}_{11}V \quad V] = [\bar{h}_{11}\mathbf{v}_1, \bar{h}_{11}\mathbf{v}_2, \dots, \bar{h}_{11}\mathbf{v}_l, \mathbf{v}_1, \mathbf{v}_2, \dots, \mathbf{v}_l] \quad (\text{A.9})$$

$$S_2 = [\bar{h}_{22}V \quad V] = [\bar{h}_{22}\mathbf{v}_1, \bar{h}_{22}\mathbf{v}_2, \dots, \bar{h}_{22}\mathbf{v}_l, \mathbf{v}_1, \mathbf{v}_2, \dots, \mathbf{v}_l] \quad (\text{A.10})$$

$$S_3 = [\bar{h}_{33}V \quad V] = [\bar{h}_{33}\mathbf{v}_1, \bar{h}_{33}\mathbf{v}_2, \dots, \bar{h}_{33}\mathbf{v}_l, \mathbf{v}_1, \mathbf{v}_2, \dots, \mathbf{v}_l] \quad (\text{A.11})$$

Let us choose \mathbf{v}_1 as 1, then if $\bar{h}_{11}, \bar{h}_{22}, \bar{h}_{33} \notin \mathbb{F}_p$, $[\bar{h}_{11}\mathbf{v}_1 \ \mathbf{v}_1]$, $[\bar{h}_{22}\mathbf{v}_1 \ \mathbf{v}_1]$ and $[\bar{h}_{33}\mathbf{v}_1 \ \mathbf{v}_1]$ are linearly independent over \mathbb{F}_p . Now let us construct \mathbf{v}_2 such that 4 columns of $S_k, k \in \{1, 2, 3\}$ are linearly independent.

$$\text{From } S_k, \ \mathbf{v}_2 \notin A_k \triangleq \left\{ \frac{(\alpha_1 \bar{h}_{kk} + \alpha_2) \mathbf{v}_1}{\beta_1 \bar{h}_{kk} + \beta_2} : \alpha_1, \alpha_2, \beta_1, \beta_2 \in \mathbb{F}_p, (\beta_1, \beta_2) \neq (0, 0) \right\}, k \in \{1, 2, 3\} \quad (\text{A.12})$$

Now we note that

$$|A_k| \leq \frac{(p^2 - 1)p^2}{p - 1} = p^3 + p^2, \quad k \in \{1, 2, 3\} \quad (\text{A.13})$$

$$|A_1 \cup A_2 \cup A_3| \leq 3(p^3 + p^2) \quad (\text{A.14})$$

There are p^n choices for \mathbf{v}_2 , and since $p^n > 3(p^3 + p^2)$ for all $p > 3$, there exist choices for \mathbf{v}_2 such that all 3 conditions of (A.12) hold. Choosing \mathbf{v}_2 from those, we note that 4 columns of $S_k, k \in \{1, 2, 3\}$ are linearly independent over \mathbb{F}_p . We proceed recursively in a similar manner, for choosing columns $\mathbf{v}_3, \mathbf{v}_4, \dots, \mathbf{v}_{l-1}$ such that $6, 8, \dots, 2(l-1)$ columns are linearly independent over \mathbb{F}_p respectively, in $S_k, k \in \{1, 2, 3\}$.

For the last iteration, we choose column \mathbf{v}_l such that all $n = 2l$ columns are linearly independent over \mathbb{F}_p in $S_k, k \in \{1, 2, 3\}$, given that $2l - 2$ columns are already linearly independent with appropriate choices of $\mathbf{v}_1, \mathbf{v}_2, \dots, \mathbf{v}_{l-1}$.

$$\text{From } S_k, \mathbf{v}_l \notin A_k \triangleq \left\{ \frac{1}{\beta_1 \bar{h}_{kk} + \beta_2} \left((\alpha_1 \bar{h}_{kk} + \alpha_2) \mathbf{v}_1 + (\alpha_3 \bar{h}_{kk} + \alpha_4) \mathbf{v}_2 + \dots + (\alpha_{2l-3} \bar{h}_{kk} + \alpha_{2l-2}) \mathbf{v}_{l-1} \right) : \alpha_i, \beta_1, \beta_2 \in \mathbb{F}_p, i \in \{1, \dots, 2l-2\}, (\beta_1, \beta_2) \neq (0, 0) \right\}, k \in \{1, 2, 3\} \quad (\text{A.15})$$

Now we note that

$$|A_k| \leq \frac{(p^2 - 1)p^{2l-2}}{p - 1} = p^{2l-1} + p^{2l-2} \quad (\text{A.16})$$

$$|A_1 \cup A_2 \cup A_3| \leq 3(p^{2l-1} + p^{2l-2}) \quad (\text{A.17})$$

There are $p^n = p^{2l}$ choices for \mathbf{v}_l , and since $p^{2l} > 3(p^{2l-1} + p^{2l-2})$ for all $p > 3$, there exist choices for \mathbf{v}_l such that conditions of (A.15) hold. Choosing \mathbf{v}_l from those, we note that all n columns of S_1, S_2, S_3 are linearly independent over \mathbb{F}_p .

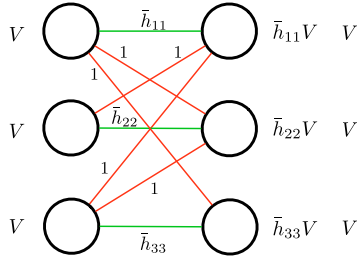

Figure A.7: Normalized channel of structure K

Hence, desired and interference symbols are linearly independent at all destinations. Thus, sum rate of $\frac{3}{2}$ is achieved for structure K in Fig. A.7, with channels over \mathbb{F}_{p^n} for all even n , if $\bar{h}_{11}, \bar{h}_{22}, \bar{h}_{33} \notin \mathbb{F}_p$.

Fraction of channels for which scheme achieves $\frac{3}{2}$ sum rate is given by

$$\left(\frac{p^n - p}{p^n}\right)^3 = \left(1 - \frac{1}{p^{n-1}}\right)^3 \rightarrow 1 \text{ for large } p, n \quad (\text{A.18})$$

The outer bound of $\frac{3}{2}$ follows from the pair-wise bounds. If all channels are equal to 1, then the argument of [11] shows that one destination can decode all messages, i.e., $C = C_{linear} = 1$. In all other cases with non-zero $\bar{h}_{kk} \in \mathbb{F}_p$ for any k , the linear capacity is still one because the linear capacity is not affected by a scaling of channel coefficients by non-zero constants in \mathbb{F}_p . Thus structure K has linear-scheme capacity of $\frac{3}{2}$ if $\bar{h}_{kk} \notin \mathbb{F}_p, k \in \{1, 2, 3\}$, and 1 otherwise.