

Lawrence Berkeley National Laboratory

Lawrence Berkeley National Laboratory

Title

Optical Synchronization Systems for Femtosecond X-ray Sources

Permalink

<https://escholarship.org/uc/item/7qs5j4x8>

Authors

Wilcox, Russell
Staples, John W.
Holzwarth, Ronald

Publication Date

2004-05-09

Optical Synchronizations Systems for Femtosecond X-Ray Sources^{*}

Russell Wilcox, John W. Staples, LBNL, Berkeley, California
Ronald Holzwarth, Menlo Systems GmbH, Martinsried

Abstract

In femtosecond pump/probe experiments using short X-Ray and optical pulses, precise synchronization must be maintained between widely separated lasers in a synchrotron or FEL facility. We are developing synchronization systems using optical signals for applications requiring different ranges of timing error over 100 meter of glass fiber. For stabilization in the hundred femtosecond range a CW laser is amplitude modulated at 1–10 GHz, the signal retroreflected from the far end, and the relative phase used to correct the transit time with a piezoelectric phase modulator. For the sub-10 fsec range the laser frequency itself is upshifted 55 MHz with an acousto-optical modulator, retroreflected, upshifted again and phase compared at the sending end to a 110 MHz reference. Initial experiments indicate less than 1 fsec timing jitter. To lock lasers in the sub-10 fs range we will lock two single-frequency lasers separated by several teraHertz to a master modelocked fiber laser, transmit the two frequencies over fiber, and lock two comb lines of a slave laser to these frequencies, thus synchronizing the two modelocked laser envelopes.

INTRODUCTION

Pump-probe experiments require synchronization between the pump and probe beam within femtoseconds (10^{-15} seconds). Glass fiber offers very wide bandwidth, low loss transmission of signals but the transmission time of the fiber itself is subject to perturbations and must be stabilized. We present systems that stabilize fiber down to the femtosecond level.

Experiments also require the synchronization of lasers to precise timing or optical frequencies. Mode-locked lasers may be stabilized to each other by selecting widely-spaced lines and synchronizing those lines to each other, resulting in the lasers themselves to be coherently locked in frequency and timing. We present details of this technique.

FIBER TIMING JITTER STABILIZATION

Glass fiber provides signal bandwidths extending into the TeraHertz (10^{12} Hz) range, accommodating a wide variety of modulation patterns. Single-mode 1550 nm commodity fiber exhibits a temperature sensitivity of 4.6 psec per hundred meters per 1.0C temperature variation. Other environmental factors, such as mechanical vibration, relaxation of the fiber itself over time or polarization effects add to the transit time variation.

Two techniques have been demonstrated at LBNL to stabilize the transit time of the fiber itself to propagate signals over a 100 meter distance. The first is to modulate the output of a CW fiber laser at a microwave (1 GHz) frequency, reflect the light at the far end of the fiber, and compare a sample of the reflected modulated signal with a sample of the initial modulated light, both detected by photodiodes. We have shown that this technique can reduce a 12 psec variation due to a 2.5C diurnal temperature variation to 200 fsec, a factor of 60 reduction. For 1 fsec timing, an interferometric technique to be used at the Atacama Radiotelescope Facility of NRAO [1] using optical frequency shifting is adopted.

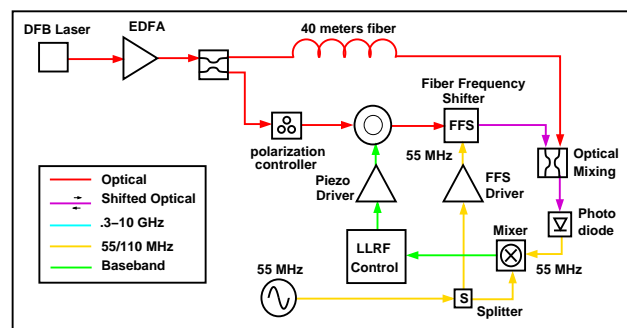

Figure 1: (color) Basic Proof-of-Principle Setup

Figure 1 shows a proof-of-principle Mach-Zehnder interferometer configuration with 30 m of fiber in one arm and a piezo-based phase modulator comprising 40 m of fiber wound around a piezo actuator in the other arm. A 1 mW 1550 nm CW laser is amplified to a +7 dBm power by an optical amplifier (EDFA in the figure) and the optical signal split by a 3 dB optical directional coupler into two legs. One leg contains the 30 m fiber and the other a polarization controller, the piezo phase modulator, and an acousto-optical frequency shifter that, through Bragg diffraction on a 55 MHz acoustic wave in an active material, precisely shifts the 1550 nm (193 THz) laser frequency up by 55 MHz. A directional coupler sums the two laser signals, and the resulting 55 MHz beat note is captured by a photodiode operating at an optical power level of 2 dBm. The resulting signal, strong enough not to require any amplification is phase compared to the 55 MHz reference signal and applied to the piezo phase modulator through suitable frequency shaping and amplification in the low-level RF controller.

With 40 meters of environmentally-exposed fiber showing several hundred fsec time jitter, closed-loop synchronization of the two channels is reduced to less than a femtosecond (0.85 is the maximum observed while manipulat-

^{*}This work supported by the US Department of Energy under Contract No. DE-AC03-76SF00098.

ing the fiber) over a bandwidth of several kiloHertz.

Figure 2 shows the application of the frequency-offset method in a practical fiber-based transmission system to carry a precise timing or frequency signal from one point to another.

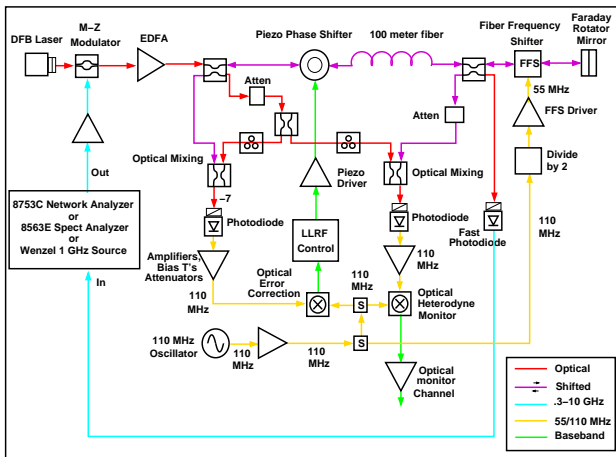

Figure 2: (color) Stabilized Transport with RF Test Signal

A CW laser signal is launched through a directional coupler, used to provide a local sample, through a piezo phase modulator into the 100 meter fiber to be stabilized.

At the far end of the fiber, an acousto-optical frequency shifter shifts the optical carrier up by 55 MHz, the light is then reflected by a Faraday rotator mirror, and the optical carrier again shifted up 55 MHz back through the frequency shifter, and the shifted light sampled at the near end of the fiber. The resulting 110 MHz beat between the shifted and original laser frequency is phase compared with the 110 MHz reference and is used to correct transit time jitter with the piezo phase modulator down to the femtosecond level. Since the heterodyning process preserves phase, phase shift in the 110 MHz reference or 55 MHz shifting frequency is reflected in the identical phase shift at optical frequency. Thus the 55/110 MHz reference need not be provided at the far end of the fiber at femtosecond accuracy, as one degree error at 110 MHz corresponds to 1 degree optical or 0.014 fsec.

To transmit information over the fiber, a wide-band zero-chirp Mach-Zehnder amplitude modulator is used to modulate a standard frequency onto the CW laser signal that will be recovered at the far end of the fiber with photodiodes or optically demultiplexing other lasers that are multiplexed onto the fiber. The loss from modulator to photodiode is low, a total of 6 dB through two 3 dB directional couplers. Figure 2 shows an RF signal, derived from a network analyzer, modulated onto the optical carrier, detected at the far end by a photodiode, and analyzed by the network analyzer for phase variation. The modulation and detection bandwidth of our system is 10 GHz.

Note that this is a linear system. Signals modulated onto the CW laser carrier at the fiber entrance do not intermodulate with each other. The optical power level is significantly

below any non-linear threshold in the fiber.

To date, waiting for a laser with a coherence length of more than a few meters to be substituted for the present laser, the configuration in Figure 1 has shown a shift of only 0.85 fsec for a perturbation of 150 fsec of the fiber with a lock range of 2 psec. A configuration similar to Figure 2 with shorter fiber lengths has achieved similar results.

SYNCHRONIZATION OF TWO LASERS

In a pulsed X-ray facility, the subsystems requiring tightest synchronization are femtosecond lasers for seeding the FEL and for experimental sample excitation. Typical pump/probe experiments require synchronization between the X-ray and optical pulses of a fraction of the pulse widths, which may be tens of femtoseconds. In developing a high precision synchronization system, we have therefore concentrated on temporal control of modelocked lasers.

In our scheme, a 1550nm modelocked fiber laser is the master clock. Two or more modelocked lasers in the facility will be synchronized with this clock, so they will be synchronized with each other. To synchronize one laser to the clock, two optical frequencies in the comb spectrum from the receiver laser are locked to two corresponding frequencies in the comb spectrum of the clock laser. Once the two sets of optical waves are matched, the two spectra are identical, and thus the pulse trains from the two lasers are synchronized in time. There can be a frequency offset between the spectra which is the same for all pairs of comb lines, corresponding to a difference in the rate of phase change of the carrier with respect to the envelope. This is acceptable, because only the envelopes are important in this application. Figure 3 illustrates this concept. Figure 4 is a

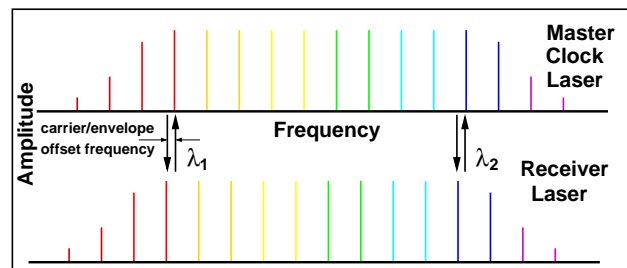

Figure 3: (color) Matching of comb spectra from two modelocked lasers.

block diagram of the basic scheme, showing a clock laser, a means of extracting two frequencies from its comb spectrum, transmitting the two frequencies, and locking a second laser to them. The absolute optical frequency reference for the system is one of the single frequency lasers, which is locked to an atomic or molecular resonance. One of the frequencies from the modelocked laser's comb is locked to this optical reference by adjusting the pulse repetition rate to null the interference between the comb line and the reference. A second single frequency laser 5THz from the first is interferometrically locked to another of the mode-

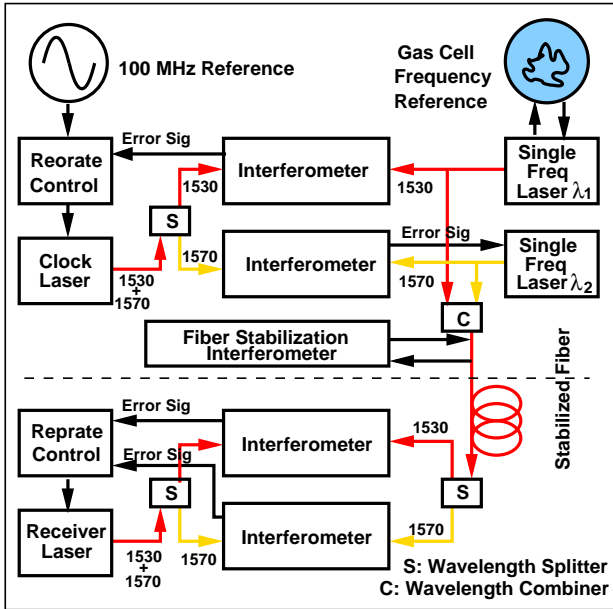

Figure 4: (color) A two Frequency Synchronization System

locked laser's comb lines. The two single frequency lasers now provide information about the modelocked laser pulse train.

The two single frequencies are transmitted through about 100m of fiber, which must be interferometrically stabilized in length. The received frequencies are interferometrically compared with two comb lines of the receiving laser to find the phase differences. These two phase differences are again subtracted to generate an error signal, which is used to control the repetition rate of the modelocked laser.

The error signal derived from the interferometers is proportional to

$$\cos(((\omega_{c1}t + \phi_{c1}) - (\omega_{r1}t + \phi_{r1})) - ((\omega_{c2}t + \phi_{c2}) - (\omega_{r2}t + \phi_{r2})))$$

where ω is radian frequency, ϕ is phase, subscripts c and r refer to the clock and receiver, 1 and 2 refer to the short and long wavelength comb lines. This term can be regrouped as

$$\cos(((\omega_{c1}t + \phi_{c1}) - (\omega_{c2}t + \phi_{c2})) - ((\omega_{r1}t + \phi_{r1}) - (\omega_{r2}t + \phi_{r2})))$$

which is the difference in phase between the 5THz beat frequencies of the clock and receiver comb line pairs respectively. Thus the phase detection is essentially comparing phase of two very high frequency waves. If the two transmitted frequencies are 5THz apart, and the phase of their beat frequency can be measured to within 2 degrees, the error just due to phase detection is 1fs.

The above example synchronizes two 1550nm fiber lasers. To synchronize a Ti:sapphire laser to two frequencies in the telecom L-band, nonlinear frequency doublers could be used as shown in Figure 5. Since the nonlinear conversion must be phase matched, the resulting 775nm lines still maintain phase coherence. Figure 3. Transmitted frequencies at 1590nm controlling a Ti:sapphire laser. In

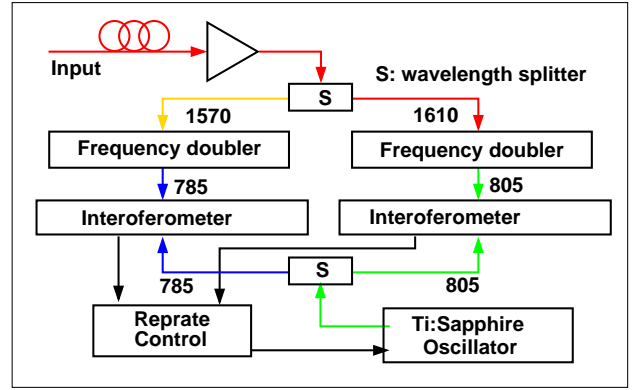

Figure 5: (color) Transmitted frequencies at 1590nm controlling a Ti:sapphire laser.

an FEL facility, there are other subsystems with less critical synchronization requirements, such as the accelerator RF cavities and the photoinjector laser. Since the arrival of a seeded X-ray pulse is weakly dependent on the bunch timing, the temporal stability of signals to these subsystems would be in the 100fs regime. Synchronization of this precision can be achieved by photodetecting an amplitude modulated CW signal, as previously demonstrated [2]. Since the master clock generates phase-synchronized comb lines, any two of these transmitted to a photodiode can be used to produce an RF signal well synchronized with the rest of the system, at lower cost than the high precision systems described above.

Transmitting a few optical frequencies has advantages over transmitting a train of short pulses. The peak optical power level required is a few milliwatts, below thresholds for Raman and Brillouin scattering, and inducing negligible self-phase modulation. Dispersion only results in a constant time shift. When the RF beat between two frequencies is detected by a photodiode, optical to RF power efficiency is maximized, as opposed to detection of a high harmonic of a modelocked pulse train where the power in all other harmonics is thrown away in bandpass filters. The peak optical power on the diode is lower, avoiding nonlinearity in the diode and resultant amplitude-to-phase conversion. Most important, phase detection in the multi-frequency scheme is measuring very high frequency beats between optical waves, rather than lower frequency microwaves, minimizing the temporal error corresponding to the lower limit on phase error.

REFERENCES

- [1] Bill Shillue, Sarmad AlBanna and Larry D'Addario, ALMA Memo 483, *The ALMA 1st Local Oscillator Reference*, <http://www.alma.nrao.edu/memos>
- [2] Josef Frisch et al, *The RF Phase Distribution and Timing System for the NLC*, Linac 2000, Monterey, p. 745