

UCLA

UCLA Previously Published Works

Title

Current commercialization status of electrowetting-on-dielectric (EWOD) digital microfluidics

Permalink

<https://escholarship.org/uc/item/7mq4589g>

Journal

Lab on a Chip, 20(10)

ISSN

1473-0197 1473-0189

Authors

Li, Jia
Kim, Chang-Jin "CJ"

Publication Date

2020

DOI

10.1039/d0lc00144a

Peer reviewed

Current commercialization status of electrowetting-on-dielectric (EWOD) digital microfluidics

Jia Li^a and Chang-Jin “CJ” Kim^{*abc}

Received 00th January 20xx,
Accepted 00th January 20xx

DOI: 10.1039/x0xx00000x

www.rsc.org/

The emergence of electrowetting-on-dielectric (EWOD) in early 2000s made the once-obscure electrowetting phenomenon practical and led to numerous activities over the last two decades. As an eloquent microscale liquid handling technology that gave birth to digital microfluidics, EWOD has served the basis for many commercial products over 2 major application areas: optical, such as liquid lens and reflective display, and biomedical, such as DNA library preparation and molecular diagnostics. A number of research or start-up companies (e.g., Phillips Research, Varioptic, Liquavista, and Advanced Liquid Logic) led the early commercialization efforts and eventually attracted major companies from various industry sectors (e.g., Corning, Amazon, Illumina). Although not all of the pioneering products became an instant success, the persistent growth of liquid lens and the recent FDA approvals of biomedical analyzers prove EWOD is a powerful tool that deserves a wider recognition and more aggressive exploration. This review presents the history around major EWOD products that hit the market to show their winding paths to commercialization and summarizes the current state of product development to peek into the future. In providing the readers with a big picture of commercializing EWOD and digital microfluidics technology, our goal is to inspire further research exploration and new entrepreneurial adventures.

Introduction

While microfluidics as technology is in general considered mature with the global microfluidics market estimated at \$8.7B for products (including \$3.8B for devices) in 2018,¹ the droplet and digital microfluidics are viewed as relatively new and niche sectors. This review deals with digital microfluidics, shown in Fig. 1, starting with electrowetting as the underlying mechanism.

Akin to the electrocapillarity by Lippmann,⁷ electrowetting makes a liquid appear more wetting on a surface than the inherent level of wetting by applying an electric field. However, the conventional electrowetting, first described in 1981 for a liquid electrolyte on metal by Beni and Hackwood,⁸ was not significant enough (e.g., contact angle change not large enough) for engineering applications. The electrowetting effect was found significant in around 1993 when a dielectric layer added on the metal surface allowed application of high voltages by University of Joseph Fourier.⁹ Coined as electrowetting-on-dielectric (EWOD)^{2,10,11} to differentiate it from the conventional electrowetting⁸ and continuous electrowetting,^{12,13} EWOD was shown capable of not only switching a droplet between beading and wetting⁹ (Fig. 2(a)) but also moving it

along desired paths on a surface (Fig. 2(b)) by Nanolytics, UCLA, and Duke University in around 2000.^{14,15,16} Soon, EWOD was shown to generate water droplets from an on-chip reservoir as well as move, split, and merge them, establishing the four essential microfluidic operations¹⁷ in air (as well as in oil) and convincing the community digital microfluidics and lab-on-a-chip applications would someday be possible. The field of electrowetting has taken off, as the growing number of publications in Fig. 3 indicates.

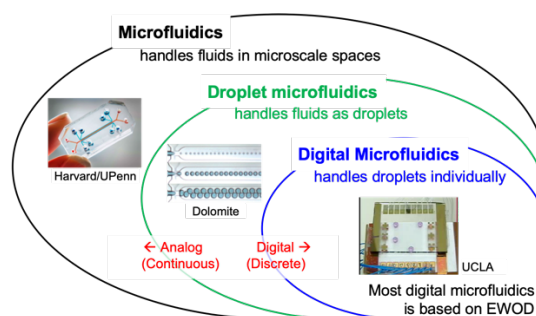

Fig. 1 As a subset of microfluidics, droplet microfluidics handles fluids as discrete entities, e.g., droplets. As a further subset, digital microfluidics can manipulate individual droplets independently. One may relate the digital microfluidics (or microfluidic circuits) to digital electronic circuits and the continuous flow microfluidics to analog circuits.^{2,3} Images adapted from ref. 4 with permission from Springer Nature, copyright 2013; from ref. 5 with permission from Dolomite Microfluidics; and from ref. 6.

^a Mechanical and Aerospace Engineering Department, University of California at Los Angeles (UCLA), Los Angeles, California 90095 USA

^b Bioengineering Department, University of California at Los Angeles (UCLA), Los Angeles, California 90095 USA

^c California NanoSystems Institute (CNSI), University of California at Los Angeles (UCLA), Los Angeles, California 90095 USA

* Email: cjkim@ucla.edu

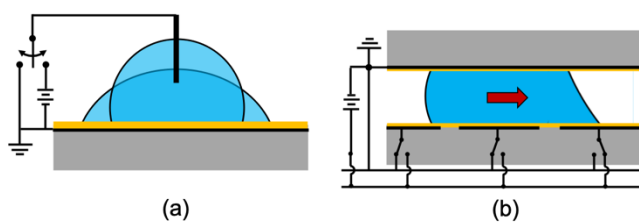

Fig. 2 Electrowetting effects shown on EWOD surface. (a) A droplet beads on or wets a hydrophobic surface with voltage off or on, respectively. (b) A droplet wets a hydrophobic surface where voltage is applied and slides to that side.

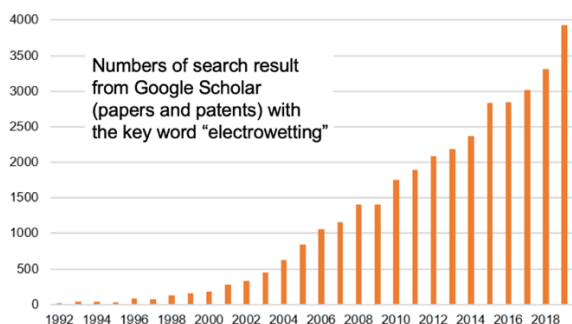

Fig. 3 The numbers of search counts in Google Scholar for the term "electrowetting" in papers and patents. Note the jump in early 2000s.

Realizing the promising utility of EWOD for applications, company activities began to emerge mainly for optical and biomedical applications while academic researchers continued exploring additional applications areas.^{18,19,20} The field of electrowetting had a strong presence of companies even from the beginning: Varioptic,²¹ Nanolytics,^{14,16} and Philips Research.²² In optical applications, Varioptic has pioneered a liquid lens and introduced a collection of products in the market, and Liquavista successfully prototyped a reflective display based on the video-speed display initiated by Philips Research.²² In biomedical, Advanced Liquid Logic has developed a DNA sample preparation instrument, and GenMark Diagnostics and Baebies introduced diagnostics instruments to perform molecular assays, immunoassays and enzymatic assays in recent years.²³ These successes led to a flurry of acquisitions involving multinational companies (e.g., Corning, Amazon, and Illumina) and attracted a slew of additional start-ups. While the strong commercialization activities helped define specific applications early on and address the well-known reliability problem of electrowetting devices, solutions to the problem were not disseminated promptly. For optical applications, EWOD devices would now survive millions of actuation cycles by optimizing the liquid materials and improving the dielectric materials and their depositions.²⁴ Although device reliability still remains as a major issue for biomedical applications, limiting the current products to handle nucleic acid solutions and prompting an opposite mechanism called electrodedewetting to eliminate the main culprits (e.g., hydrophobic coating),²⁵ the persisting success of liquid lenses and the recent FDA approvals of diagnostic instruments testify that EWOD is a powerful and versatile technology with a wide and far-reaching potential for the years to come.

In this review, we summarize the history behind the electrowetting products that hit the market and their paths to the commercialization. The goal is to give readers a big picture

of electrowetting in industry, providing a chance for academic researchers to appreciate the relevance of their work and encouraging potential entrepreneurs to explore new adventures.

The liquid lens

An aqueous droplet that beads on a hydrophobic surface can be switched to appear wetting the surface by applying an electric potential between the droplet and the substrate, as illustrated in Fig. 2(a). University of Joseph Fourier (Grenoble, France) filed a patent of variable focus lens consisting of a sessile drop in an immiscible liquid actuated by EWOD (Fig. 4(a)) in 1997,²¹ and its inventor Bruno Berge founded Varioptic (Lyon, France) in 2002. Compared with the conventional motorized lens, the liquid lens has many advantages: (i) no wear and silent operation, (ii) fast actuation (< 50 ms), (iii) high mechanical shock resistance (> 2000 g), and (iv) low power consumption (< 20 mW with driver).²⁶ In competition, Philips Research developed its liquid lens and demonstrated a camera in 2004.^{27,28} In addition to controlling the focal length by EWOD, both companies developed additional functions such as variable tilt and image stabilization and also found optical aberration can be greatly reduced by adding a resistive layer between the insulation layer.^{29,30} Varioptic began its first shipment of the liquid lens in 2007 produced by Creative Sensor (Nanchang, China) but later partnered with Seiko Instruments (Chiba, Japan) for mass manufacturing. While Philips terminated its liquid lens project in 2011²⁴ by the competition with voice coil motor for camera phones and a small market for endoscopes, etc., Varioptic chose diverse and niche market including machine barcode readers³¹, intraoral cameras,³² cell counters,³³ ophthalmology,³⁴ biometrics,³⁵ and low vision devices.³⁶ In recent years (since 2017), Verily Life Sciences, formerly Google Life Sciences and a subsidiary of Alphabet (Mountain View, USA), has filed multiple patents on electrowetting-based contact lens.^{37,38} It is to be seen whether they will lead to commercial products.

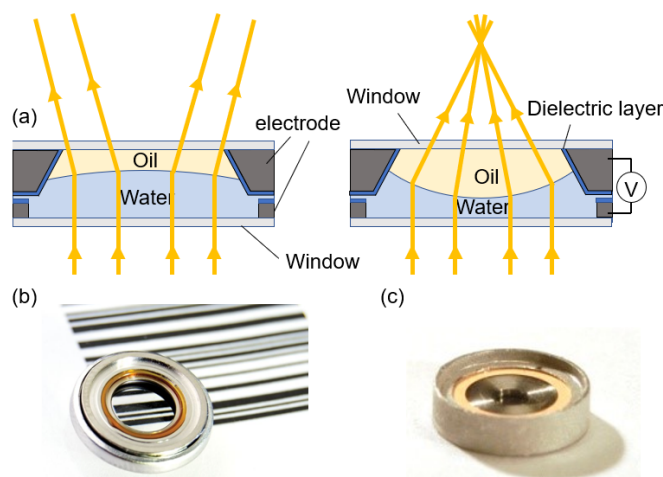

Fig. 4 Variable focus liquid lens. (a) Upon applying voltage, the water-oil meniscus changes its curvature, altering the focal length of the lens. (b) Varioptic's liquid lens assembly placed on a barcode, adapted from ref. 39 with permission from Corning Technology Center - Lyon. (c) Philips' liquid lens for camera phones, courtesy of S. Kuiper.

Varioptic has gone through several changes and expansions in the 2010s, as schematically summarized in Fig. 5. In 2011, Varioptic was acquired by Parrot (Paris, France), a company well known for camera drones. At the same time, Optilux (Santa Barbara, USA) was founded with an exclusive right to use the liquid lens in smart phones and tablets. Then, as an interesting turn of events, Invenios (Santa Barbara, USA), a microfabrication foundry specializing in glass-based gene sequencing chip and microfluidic devices, acquired Optilux in 2013 and Varioptic from Parrot in 2016, only to be acquired immediately (in 2017) by Corning, a Fortune (Global) 500 Company specializing in glass and ceramics. Currently the Varioptic liquid lenses are marketed as Corning Varioptic Lenses (Fig. 4(b)).

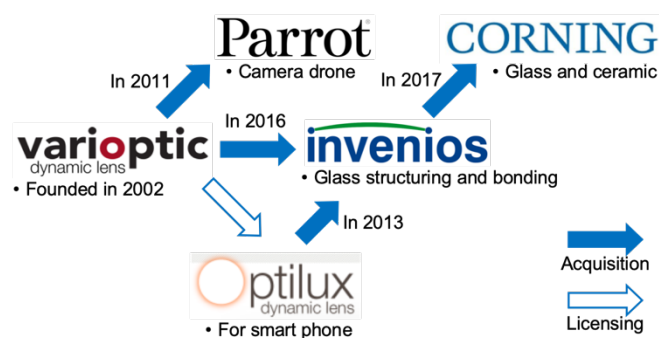

Fig. 5 History of the liquid lens business. Varioptic has been the world leader in liquid lens technology and the first example of successful commercialization for electrowetting. They are now Corning Varioptic Lenses.

The reflective display

A droplet switched between beading and spreading on a hydrophobic surface, as illustrated in Fig. 2(a), can also be used as a switchable pixel for optical images, as illustrated in Figs. 6(a,b). Philips Research (Eindhoven, the Netherlands) filed an electrowetting display patent in 2002,⁴⁰ and its inventors Johan Feenstra and Robert Hayes founded a spinoff Liquavista (Eindhoven, the Netherlands) in 2006. Compared with an electrophoretic display (E-ink), their electrowetting-powered display was fast enough to play video contents.²² They moved forward to commercialize the display by improving its contrast, brightness, saturation, speed, power consumption, and reliability while achieving grayscale, full-color, and trans-reflective displays.

Liquavista was acquired by Samsung Electronics (Suwon, S. Korea) in 2010 and the technology matured.⁴¹ However, Samsung changed business strategy and Amazon (Seattle, U.S.A.) purchased the business in 2013 to develop color reflective video displays. We believe they aimed to improve its e-reader, which is monochrome and has slow refresh rate. Amazon was building a production team in Shenzhen, China as late as 2016,⁴² but it shut down Liquavista at the end of 2018. Although the reason for the shutdown is not known, one can imagine a change of focus in the business strategy, technical challenges as well as fierce competitions, such as CLEARink with another video-speed reflective display technology.

Consumer market is not the only playing field for reflective displays. As Liquavista was being founded, Hans Feil founded

Miortech (Eindhoven, the Netherlands) in 2006 as a spinoff of Liquavista and formed Etulipa (Eindhoven, the Netherlands) as a subsidiary of Miortech in 2013 to develop outdoor digital signage using electrowetting. Compared with Liquavista's architecture which placed cell walls on the hydrophobic layer of the bottom glass⁴³, Etulipa mounted the cell walls on the top glass and extended it to the bottom glass⁴⁴. Reflective displays are attractive for outdoor signage not only because of its readability in bright light but also because they do not create light pollution. Because digital signs – much larger than electronic paper – require assembling of multiple tiles, Etulipa added an optical waveguide on top of electrowetting display tiles to make them visibly seamless.⁴⁵ Unique challenges are to assure superior reliability to withstand the harsh outdoor conditions, such as flying particles, rain, temperature cycles, and sun radiation. While maturing the technology for a wide range of outdoor applications, their first application is an electronically changeable copy board (eCCB) named Carbon, boasting clear black digital lettering. The tiles that constitute the copy board are manufactured in United Radiant Technology (Taichung, Taiwan).

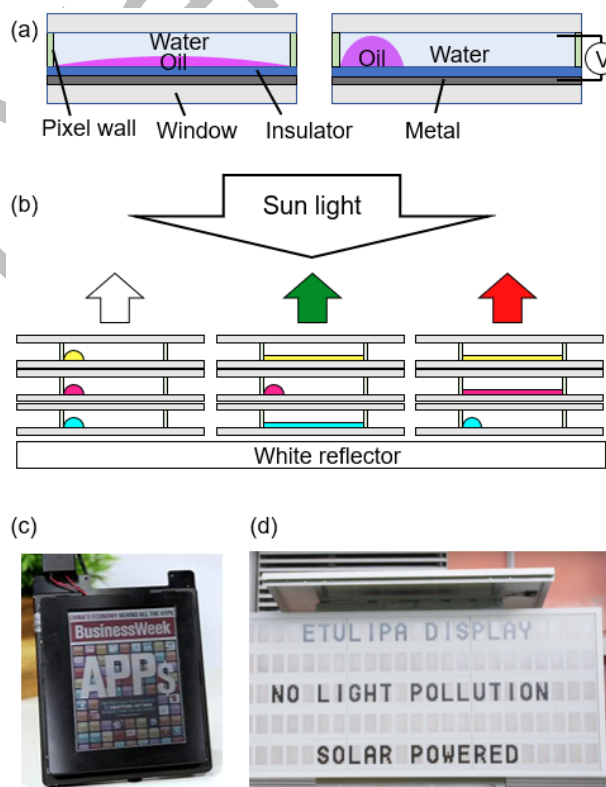

Fig. 6 Electrowetting-powered reflective display. (a) Working principle of a single cell of an electrowetting display. When voltage is applied, e.g., 15 V, the dyed oil droplet is pushed away by wetting of the water. (b) Simplified working principle of an electrowetting colour reflective display, adapted from ref. 46 with permission from Etulipa. (c) A tablet with Liquavista's display.⁴⁷ (d) Etulipa's outdoor display powered by solar energy, adapted from ref. 48 with permission from Etulipa.

Figure 7 schematically summarizes the history of electrowetting-powered reflective display business until today. Recently, a team led by GuoFu Zhou and Alexander Henzen

(former Philips employees who had earlier founded IReX Technologies, an electronic paper company spun off from Philips) is also commercializing electrowetting display in South China Normal University (China) and Shenzhen Guohua Optoelectronics (Shenzhen, China). It is still to be seen how the above three will overcome the challenges and bring attractive products to the market.

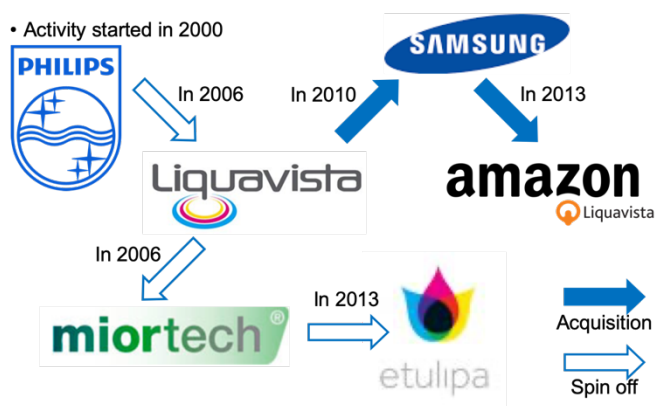

Fig. 7 History of electrowetting-based reflective display business. Liquavista has pioneered electronic paper but encountered a recent setback. Currently, the utilities are expanding to outdoor applications.

Digital microfluidics for biochemical assays

One can induce an aqueous droplet to slide on a hydrophobic surface by applying an electric potential between the droplet and the substrate only under one side of the droplet, as illustrated in Fig. 2(b). Since it implies multiple droplets can be physically moved purely by electric signals, dramatically simpler microfluidics devices have become possible without calling for any physical pumps or valves, and a lab-on-a-chip could be envisioned, as illustrated in Fig. 8.

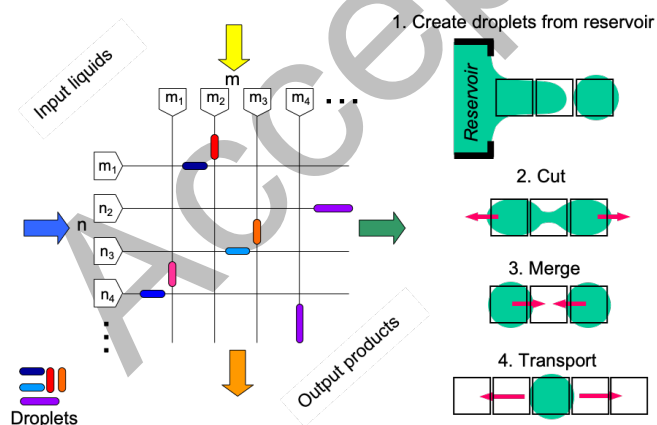

Fig. 8 Digital microfluidics and lab-on-a-chip application envisioned by manipulating a liquid by EWOD technology, adapted from refs. 2 and 17.

Alex Shenderov filed a patent for a device capable of manipulating droplets on a surface by EWOD actuation in 1999¹⁴ and founded Nanolytics (Raleigh, U.S.A.). Independently,

UCLA (Los Angeles, U.S.A.) filed a similar patent in 2000,¹⁵ and its inventor CJ Kim (the corresponding author of this paper) founded Core MicroSolutions (Los Angeles, U.S.A.) in 2002. Based on the collaborative research between Nanolytics and Richard Fair's lab in Duke University,¹⁶ Michael Pollack and Vamsee Pamula founded Advanced Liquid Logic (Morrisville, U.S.A.) in 2004. All the three companies explored to commercialize EWOD digital microfluidics for a wide range of applications but mostly biomedical, such as accelerating drug discovery process by replacing robotic manipulations of liquids with EWOD digital microfluidic manipulations. Eventually, Advanced Liquid Logic acquired Nanolytics in 2007 and Core MicroSolutions in 2009 before being acquired by Illumina (San Diego, U.S.A.) in 2013. Figure 9 schematically summarizes the history of digital microfluidics companies based mostly on PCB substrate.

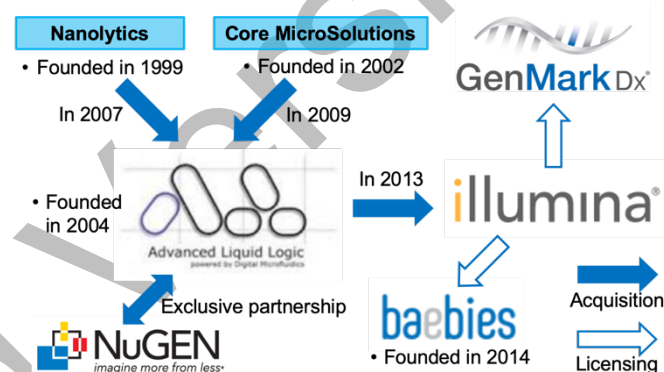

Fig. 9 History of EWOD digital microfluidics business around Advanced Liquid Logic, which played a key role for two main products of today: GenMark's ePlex System for molecular diagnostics and Baebies' SEEKER for enzymatic assays for new borns.

Prior to the above acquisition, NuGEN Technologies (Redwood City, U.S.A, now part of Tecan Group in Männedorf, Switzerland) introduced a digital microfluidics-based DNA library preparation instrument called Mondrian SP Workstation⁴⁹ in 2011 in partnership with Advanced Liquid Logic. After the 2013 acquisition of Advanced Liquid Logic, Illumina launched a similar, expanded product called NeoPrep Library Prep System⁵⁰ in 2015, shown in Fig. 10. Performing the majority of sample preparation steps automatically (e.g., magnetic bead-based operations, thermal cycling, and optical detection) by EWOD, the system completed sample preparation in ~30 min instead of the 4-5 hours of manual operation by users. Unfortunately, this system was discontinued in 2017 for undisclosed reasons, which are generally understood as reliability problems⁵¹ likely caused by underestimating the challenges of engineering and manufacturing (the authors' opinion).

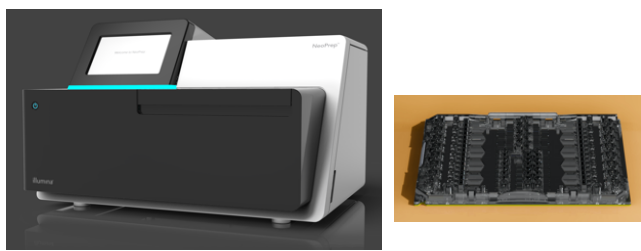

Fig. 10 Illumina's NeoPrep System and its consumable, adapted from ref. 52 with permission from J. Kurihara.

The setback of NeoPrep by Illumina did not discourage other sequencing companies from employing the EWOD digital microfluidic technology for similar goals. MGI, a subsidiary of BGI, launched DNBelab D series, a DNA sample preparation platform in 2019.⁵³ Oxford Nanopore Technologies (Oxford, United Kingdom) launched VolTRAX V2, shown in Fig. 11, for DNA/RNA library preparation in 2018. Their consumables (the TFT based EWOD devices⁵⁴) are supplied by Aqdrop (Oxford, United Kingdom). Compared with NeoPrep, VolTRAX V2 has several advantages for better reliability. First, its EWOD device is made of glass substrate using LCD manufacturing method instead of the PCB substrate employed for NeoPrep's EWOD device. Compared with the PCB-based, the glass-based EWOD device has a smoother (i.e., less surface topology) surface, allowing a thinner dielectric layer and ensuring better control of the liquid volume. Second, a feedback detection of liquid volumes is implemented in the system, allowing the users to dispense exact volumes of liquids into the device. Third, by reducing the number of libraries running at a time, their cartridge has a smaller chance to fail than the NeoPrep's cartridge that runs 16 libraries in parallel. Although the NeoPrep's cartridge was not large enough to run parallel experiments, it utilized methods such as DNA barcode to perform multiple sample processes.



Fig. 11 Oxford Nanopore's automatic sample preparation on system for nanopore analyses, reproduced from ref. 55 with permission from Oxford Nanopore Technologies.

Before the 2013 acquisition by Illumina, Advanced Liquid Logic was working with GenMark Diagnostics (Carlsbad, U.S.A.) to explore a fully integrated in-vitro diagnostic platform that detects DNA/RNA targets using GenMark's eSensor[®]. GenMark obtained a license and continued the development to complete ePlex System shown in Fig. 12, which is built to operate multiplex panels each for a certain disease diagnostics. Their ePlex System and the first panel (the respiratory pathogen or RP panel) were FDA cleared in 2017, and two other panels (the

blood culture identification for Gram positive organisms or BCID-GP panel and the blood culture identification for fungal organisms or BCID FP panel) were FDA cleared in 2018, with additional panels in the pipeline. Currently, the GenMark ePlex system with its panels is considered to be the most sophisticated and versatile electrowetting product in the market.

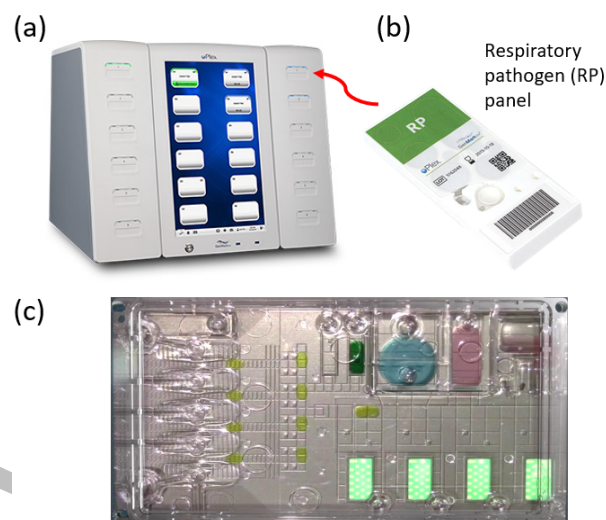

Fig. 12 GenMark Diagnostics' ePlex system and its consumable. (a) The system.⁵⁶ (b) The respiratory pathogen panel.⁵⁷ (c) Inside the panel, electrowetting is used to prepare samples for automatic molecular diagnostics.⁵⁷ The images are adapted with permission from GenMark Diagnostics.

In collaboration with the Neonatal-Perinatal Research Institute of Duke University, Advance Liquid Logic developed a molecular diagnostic system to detect lysosomal storage disorders (LSDs) for newborn babies. After the 2013 Illumina acquisition, Vamsee Pamula and Richard West obtained the license from Illumina and formed Baebies (Durham, U.S.A.) in 2014 to continue commercializing the LSDs screening system and screening services for newborns. Their instrument SEEKER, shown in Fig. 13, was FDA approved in 2017.

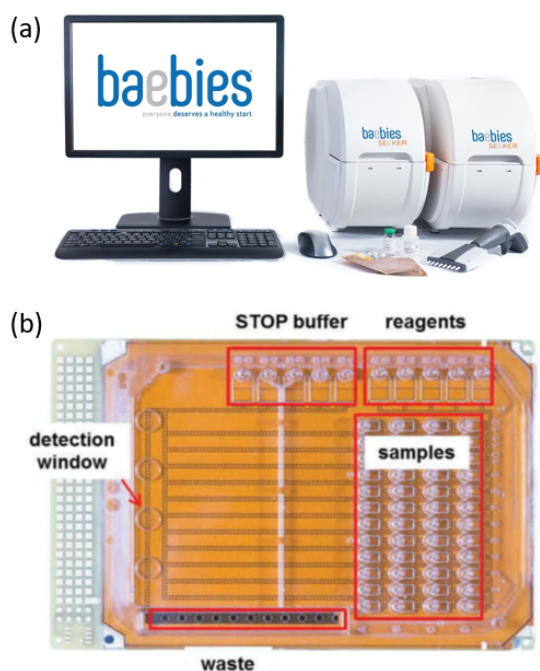

Fig. 13 Baebies' SEEKER. (a) The system.⁵⁸ (b) The consumable.⁵⁹ The images are adapted with permission from Baebies.

Other companies and products

In recent years, more companies or products based on electrowetting started to emerge, mostly in biomedical applications. Spun off the University of Twente (Enschede, the Netherlands) in 2012, eMaldi⁶⁰ (Enschede, the Netherlands) provides more sensitive signals for matrix-assisted laser desorption ionization mass spectrometry (MALDI-MS). Founded in 2012, Nicoya⁶¹ (Kitchener, Canada) integrated digital microfluidics into a surface plasmon resonance (SPR) system to launch Alto in 2020⁶². Founded in 2012 as an electrowetting spinoff of the University of Toronto, Kapplex (Toronto, Canada) was acquired in 2016⁶³ by a microRNA-detection company Miroculus (San Francisco, U.S.A.) to develop a sequencing library prep platform.⁶⁴ Unlike Illumina's NeoPrep System, their system does not use the filler oil.⁶⁵ Founded in 2016 and currently in an accelerator program hosted by Merck, Digi.Bio⁶⁶ (Amsterdam, the Netherlands) supplies their system and consumables to various companies, including Levels Diagnostics, as well as targeting own biochemical applications. A joint venture formed in 2017 by Sharp (Sakai, Japan) and Hon Hai Precision Industry (a.k.a. Foxconn) (Taipei, Taiwan), Aqdrop⁶⁷ (Oxford, United Kingdom) allows one to manipulate hundreds of droplets in one chip. They are currently supplying the TFT thin-film based EWOD devices to Oxford Nanopore Technologies but also exploring a wide range of biochemical applications in genomics, proteomics, cellomics, and synthetic biology. Founded in 2018, Digifluidic Biotech⁶⁸ (Zhuhai, China) integrates DNA melting curve analysis with digital microfluidics for fast nucleotide detection. Digifluidic Biotech and GenMark Diagnostics are currently working on coronavirus detection kit.^{69,70} Lastly, it is worth noting some recent initiatives to lower the initial barrier to electrowetting technology,^{71,72,73} by recognizing that the burden of engineering and manufacturing

too often discourages individuals and labs, who may otherwise utilize electrowetting for own ideas and applications.⁷³

Conclusions

This review has summarized the history and status of the major commercialization activities of electrowetting technologies, covering liquid lens, electronic displays, and various biochemical applications. The big picture reveals a few trends and teaches some good lessons. First, almost every electrowetting company worked on unique applications quite different from others even through the underlying technologies are similar. As different companies are focusing on different applications and pursuing different markets, the competition is still relatively mild. The efforts to address the reliability problems from the early days led to the breakthroughs for today's optical products. Second, while some of the ambitious products have experienced setbacks (Liquavista's electronic paper and Illumina's DNA/RNA library preparation system), they did not discourage others from continuing to pursue similar goals. Instead, others learned valuable lessons and adjusted their strategies to improve the product reliability or shift the target market. Third, the success of Advanced Liquid Logic suggests that collaborating with mature biochemical companies is important to explore biochemical applications – easy to say than do in practice. Fourth, now approximately 20 years after the first electrowetting company was founded and with most of the fundamental patents expired or approaching expirations, we started to see a surge of start-up companies formed and being formed and new products being developed and launched, as new applications continue to be discovered. Understanding the practical limitations of EWOD devices better and also learning how to design and manufacture more reliable EWOD product, the chances of success have been increasing for new companies and new product, allowing them to harvest from the wide potential of electrowetting and EWOD technologies.

Conflicts of interest

C.-J.K. is an inventor of multiple UCLA patents licensed to Illumina and being financially benefitted.

Acknowledgements

This work was supported by the National Science Foundation (1711708 and 1720499) and the Volgenau Endowed Chair in Engineering. Inputs and comments from the following individuals are greatly appreciated: Johan Feenstra, Hans Feil, Stein Kuiper, and Richard B. Fair.

Notes and references

- 1 S. Clerc and A. Siari, Status of the microfluidics industry 2019, Yole Développement, 2019. Downloadable: www.i-micronews.com/products/status-of-the-microfluidics-industry-2019/
- 2 C.-J. Kim, Micropumping by electrowetting, *Proceedings of 2001 ASME International Mechanical Engineering Congress and Exposition*, 2001, IMECE2001/HTD-24200.

- 3 M. G. Pollack, A. D. Shenderov and R. B. Fair, Electrowetting-based actuation of droplets for integrated microfluidics, *Lab Chip*, 2002, **2**, 96–101.
- 4 D. Huh, H. Kim, J. Fraser, D. E. Shea, M. Khan, A. Bahinski, G. A. Hamilton and D. E. Ingber, Microfabrication of human organs-on-chips. *Nat. Protoc.*, 2013, **8**, 2135–2157.
- 5 <https://www.labmate-online.com/news/laboratory-products/3/dolomite-microfluidics-hq/micro-droplet-systems-enable-fast-and-advanced-droplet-microfluidics/11998>
- 6 S.-K. Fan, C. Hashi, and C.-J. Kim, Manipulation of multiple droplets on NxM grid by cross-Reference EWOD driving scheme and pressure-contact packaging. *Proc. Int. IEEE Conf. Micro Electro Mechanical Systems*, 2003, 694–697.
- 7 G. Lippmann, Relation entre les phénomènes électriques et capillaires, *Ann. Chim. Phys.*, 1875, **5**, 494–549.
- 8 G. Beni and S. Hackwood, Electro - wetting displays, *Appl. Phys. Lett.*, 1981, **38**, 207–209.
- 9 B. Berge, Électrocapillarité et mouillage de films isolants par l'eau, *C. R. Acad. Sci. Paris, Série II*, 1993, **317**, 157–163.
- 10 J. Lee, H. Moon, J. Fowler, C.-J. Kim and T. Schoellhammer, Addressable micro liquid handling by electric control of surface tension, *Tech. Dig., IEEE Int. Conf. Micro Electro Mechanical Systems*, 2001, 499–502.
- 11 J. Lee, H. Moon, J. Fowler, T. Schoellhammer and C.-J. Kim, Electrowetting and electrowetting-on-dielectric for microscale liquid handling. *Sensors Actuators A Phys.*, 2002, **95**, 259–268.
- 12 G. Beni, S. Hackwood and J. L. Jackel, Continuous electrowetting effect, *Appl. Phys. Lett.*, 1982, **40**, 912–914.
- 13 J. Lee and C.-J. Kim, Surface-tension-driven microactuation based on continuous electrowetting. *J. Microelectromech. Syst.*, 2000, **9**, 171–180.
- 14 A. D. Shenderov, Actuators for microfluidics without moving parts, *U.S. Patent No. 6,565,727*, 2003, Priority 1999.
- 15 C.-J. Kim and J. Lee, Electrowetting-driven micropumping, *U.S. Patent No. 8,529,743*, 2013, Priority 2000.
- 16 M. G. Pollack, R. B. Fair and A. D. Shenderov, Electrowetting-based actuation of liquid droplets for microfluidic applications, *Appl. Phys. Lett.*, 2000, **77**, 1725–1726.
- 17 S. K. Cho, H. Moon and C.-J. Kim, Creating, transporting, cutting, and merging liquid droplets by electrowetting-based actuation for digital microfluidic circuits, *J. Microelectromech. Syst.*, 2003, **12**, 70–80.
- 18 P. Sen and C.-J. Kim, A Liquid–Solid Direct Contact Low-Loss RF Micro Switch. *J. Microelectromechanical Syst.*, 2009, **18**, 990–997.
- 19 W. C. Nelson, H. P. Kavehpoor and C.-J. Kim, A miniature capillary breakup extensional rheometer by electrostatically assisted generation of liquid filaments, *Lab Chip*, 2011, **11**, 2424–2431.
- 20 R. S. Hale and V. Bahadur, Electrowetting-based microfluidic operations on rapid-manufactured devices for heat pipe applications, *J. Micromechanics Microengineering*, 2017, **27**, 075004.
- 21 B. Berge and P. Jerome, Lens with variable focus, *U.S. Patent No. 6,369,954*, 2002, Priority 1997.
- 22 R. A. Hayes and B. J. Feenstra, Video-speed electronic paper based on electrowetting, *Nature*, 2003, **425**, 383–385.
- 23 R. S. Sista, R. Ng, M. Nuffer et al., Digital microfluidic platform to maximize diagnostic tests with low sample volumes from newborns and pediatric patients. *Diagnostics*, 2020, **10**, 21.
- 24 F. Mugele and J. Heikenfeld, Electrowetting: fundamental principles and practical applications. *John Wiley & Sons*, 2018.
- 25 J. Li, N. S. Ha, T. Liu, R. M. van Dam and C.-J. Kim, Ionic-surfactant-mediated electro-dewetting for digital microfluidics, *Nature*, 2019, **572**, 507–510.
- 26 <http://www.chronix.co.jp/chronixjp/products/picture/varioptic/pdf/Varioptic%20presentation%20v6.0%20-%20V2.pdf>
- 27 <https://optics.org/article/19178>
- 28 <https://www.businesswire.com/news/home/20040317005366/en/Varioptic-Enforce-Liquid-Lens-Patent-Rights>
- 29 B. Berge, N. Verplanck, M. Maillard and J. Legrand "Optical electrowetting device." *U.S. Patent No. 8,649,102*, 2014, Priority 2008.
- 30 S. Kuiper et al., Apparatus for forming variable fluid meniscus configurations. *U.S. Patent No. 7,808,717*, 2010, priority 2002.
- 31 <https://microscan.com/en-us>
- 32 <https://www.carestreamdental.com/en-us/>
- 33 <https://logosbio.com/automated-cell-counters/brightfield/luna-ii>
- 34 <http://www.tomey.com/tomeycorp/product.html>
- 35 <https://www.idemia.com>
- 36 <https://www.esighteyewear.com/>
- 37 S. Kuiper and D. Otts, Electrowetting lenses having oleophobic surfaces, *U.S. Patent Application Publication No. 2019/0060055*, 2019, Priority 2017.
- 38 D. Otts and S. Kuiper, Situ filling and sealing of electrowetting intraocular lenses, *U.S. Patent Application Publication No. 2018/0318068*, 2018, Priority 2017.
- 39 <https://www.corning.com/worldwide/en/innovation/corning-g-emerging-innovations/corning-varioptic-lenses/varioptic-technology.html>
- 40 B. J. Feenstra, R. A. Hayes and M. W. J. Prins, Display device, *U.S. Patent No. 7,898,718*, 2011, Priority 2002.
- 41 <https://the-digital-reader.com/2012/03/21/samsung-electrowetting-screen-tech-to-hit-mass-production-next-year/#.UEdIe15VVy4>
- 42 <https://goodereader.com/blog/e-paper/amazon-is-building-a-production-team-in-china-for-liquavista-displays>
- 43 S.-W. Jung, S.-M. Seo and S.-H. Yang. Display substrate, method of manufacturing the same and electro-wetting display panel having the same. *U.S. Patent No. 9,728,675*, 2017, Priority 2012.
- 44 H. Feil, Electrowetting optical element. *U.S. Patent No. 9,274,331*, 2016, Priority 2010.
- 45 H. Feil and D. J. Oostra, Optical seam reduction. *U.S. Patent No. 9,885,826*, 2018, Priority 2013.
- 46 <https://etulipa.com/wp-content/uploads/2017/04/whitepaper-VP-Paper-Electronic-Display-Conference-2017.pdf>
- 47 <https://www.youtube.com/watch?v=VJUMRZesBvK>
- 48 <https://www.youtube.com/watch?v=mo7NNEIEu80>
- 49 <https://www.youtube.com/watch?v=niGt2q7CKfw>
- 50 <https://support.illumina.com/content/dam/illumina-marketing/documents/products/brochures/brochure-neoprep.pdf>
- 51 <http://omicsomics.blogspot.com/2017/02/illumina-drops-neoprep.html>
- 52 <http://www.jun-k-design.com/>
- 53 <https://www.prnewswire.com/news-releases/mgi-launches-first-benchttop-sequencing-laboratory-and-automation-products-300945621.html>
- 54 B. Hadwen, G. R. Broder, D. Morganti, A. Jacobs, C. Brown, J. R. Hector, Y. Kubotac and H. Morgan, Programmable large area digital microfluidic array with integrated droplet sensing for bioassays, *Lab Chip*, 2012, **12**, 3305–3313.
- 55 <https://nanoporetech.com/prepare>
- 56 <https://www.genmarkdx.com/solutions/systems/eplx-system/>
- 57 <https://www.genmarkdx.com/solutions/panels/eplx-panels/respiratory-pathogen-panel/>
- 58 <https://baebies.com/products/seeker/>

- 59 D. Millington, S. Norton, R. Singh, R. Sista, V. Srinivasan and V. Pamula, Digital microfluidics comes of age: high-throughput screening to bedside diagnostic testing for genetic disorders in newborns, *Expert review of molecular diagnostics*, 2018, **18**, 701–712.
- 60 <http://e-maldi.com/#intro>
- 61 <https://www.alto.nicoyalife.com/>
- 62 <https://www.acceleratorcentre.com/news/nicoya-launches-alto-the-worlds-first-digital-benchtop-spr-system-to-accelerate-drug-discovery>
- 63 <https://www.globenewswire.com/news-release/2016/05/03/836085/10162356/en/Miroculus-acquires-Kaplex-to-advance-diagnostics-for-complex-diseases.html>
- 64 <https://www.businesswire.com/news/home/20200224005151/en/>
- 65 M. J. Jebrail et al., Air-matrix digital microfluidics apparatuses and methods for limiting evaporation and surface fouling. *U.S. Patent No. 10,464,067*, 2019, Priority 2015.
- 66 <https://digi.bio>
- 67 <https://www.aqdrop.com/showcase/>
- 68 <http://digifluidic.com/>
- 69 <https://www.um.edu.mo/news-centre/news-and-events/news-and-press-releases/detail/49948/>
- 70 <http://ir.genmarkdx.com/news-releases/news-release-details/genmark-diagnostics-announces-submission-emergency-use>
- 71 <http://www.gaudi.ch/OpenDrop/>
- 72 <https://sci-bots.com/>
- 73 J. Li and C.-J. Kim, Cybermanufacturing ecosystem for expanding electrowetting community, In *Abstract Book of the 11th International Conference on Electrowetting and Drop Dynamics on Functionalized Surfaces*, Enschede, the Netherlands, 2018 (accessible at <http://2018.electrowetting.org/doc/booklet.pdf>).