

# UC Irvine

## UC Irvine Previously Published Works

### Title

Analysis Strategies for Tubular Solid Oxide Fuel Cell Based Hybrid Systems

### Permalink

<https://escholarship.org/uc/item/7g03x5h3>

### Journal

Journal of Engineering for Gas Turbines and Power, 124(3)

### ISSN

0742-4795

### Authors

Rao, AD  
Samuelsen, GS

### Publication Date

2002-07-01

### DOI

10.1115/1.1413462

### Copyright Information

This work is made available under the terms of a Creative Commons Attribution License, available at <https://creativecommons.org/licenses/by/4.0/>

Peer reviewed

# Analysis Strategies for Tubular Solid Oxide Fuel Cell Based Hybrid Systems

A. D. Rao

G. S. Samuelsen

National Fuel Cell Research Center,  
University of California,  
Irvine, CA 92697

*The emergence of fuel cell systems and hybrid fuel cell systems requires the evolution of analysis strategies for evaluating thermodynamic performance and directing design and development. A description and application of the recently developed tool for analyzing tubular SOFC based systems is presented. The capabilities of this tool include an analytical model for the tubular SOFC derived from first principles and the secondary equipment required to analyze hybrid power plants. Examples of such secondary equipment are gas turbine, reformer, partial oxidation reactor, shift reactor, humidifier, steam turbines, compressor, gas expander, heat exchanger, and pump. A "controller" is included which is essential for modeling systems to automatically iterate in order to meet the desired process or system design criteria. Another important capability that is included is to be able to arrange the various components or modules as defined by the user in order to configure different hybrid systems. Analysis of the hybrid cycle as originally proposed by Westinghouse (SureCell™) indicates that the thermal efficiency of the cycle is quite insensitive to the pressure ratio, increasing from 65.5 percent to 66.6 percent on a lower calorific value of the fuel as the pressure ratio decreases from 15 to 6.5. [DOI: 10.1115/1.1413462]*

## Introduction

Due to the projected increases in fossil fuel usage world wide, the greenhouse gas emissions of CO<sub>2</sub> to the atmosphere are expected to increase by about 60 percent by 2015 over the 1990 level. The CO<sub>2</sub> generated from a given fuel per unit of power produced is inversely proportional to the thermal efficiency of a power plant, assuming complete utilization of the fuel. In addition to CO<sub>2</sub>, pollutants such as oxides of sulfur, oxides of nitrogen, and unburned hydrocarbons are introduced into the atmosphere when combustion is used to harness the chemically bound energy of the fuel. The amount of pollutants emitted to the atmosphere which depend on the degree of pollution abatement measures incorporated, typically increase the plant operating and capital costs. Thus, a need exists to develop energy efficient means of power generation while minimizing the environmental impact; fuel cells hold this promise.

Furthermore, distributed power generation which is gaining much attention from industry could be a niche market for fuel cells if configurations can be identified that are simple so that the plant capital cost and the process controllability are not compromised.

A fuel cell, as an electrochemical device is similar to a battery that converts chemically bound energy directly into electricity but unlike conventional batteries, the chemical energy to the cell is supplied on a continuous basis in the form of a fuel such as natural gas or synthesis gas while the oxidant (air) is also supplied continuously. Higher conversion efficiencies are achievable with a fuel cell when compared to heat engines since the fuel cell is not constrained by the Carnot cycle efficiency. In a fuel cell, where the chemical energy is directly converted into electricity, the intermediate step of conversion into heat as in a heat engine is eliminated. In a fuel cell, there are some heat effects that do limit the conversion of the fuel bound energy to electricity. These heat effects are due to

- 1 heating of the reactants to the reaction temperature and cooling of the products from the reaction temperature
- 2 the entropy change of the reaction
- 3 irreversibilities in the cell due to cell polarizations.

A schematic representation of a tubular SOFC stack is depicted in Fig. 1 while Fig. 2 shows the cross section of a tube. The oxidant is preheated in the central injector tube and then enters the annular section between the cathode layer and the injector tube while the fuel flows over the outer anode layer. Note that in the current design, the support tube depicted in Fig. 2 has been eliminated by Seimens-Westinghouse.

The electrochemical reactions occurring within the cell for H<sub>2</sub> as the fuel are

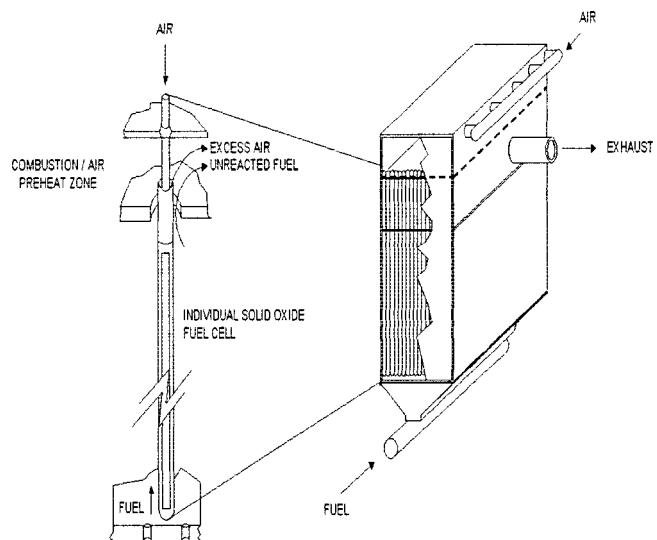
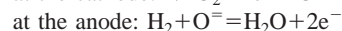
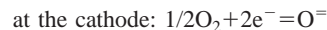

Fig. 1 Schematic representation of tubular SOFC stack ([2])

Contributed by the International Gas Turbine Institute (IGTI) of THE AMERICAN SOCIETY OF MECHANICAL ENGINEERS for publication in the ASME JOURNAL OF ENGINEERING FOR GAS TURBINES AND POWER. Paper presented at the International Gas Turbine and Aeroengine Congress and Exhibition, Munich, Germany, May 8–11, 2000; Paper 00-GT-553. Manuscript received by IGTI, Nov. 1999; final revision received by ASME Headquarters, Feb. 2000. Associate Editor: D. Wisler.

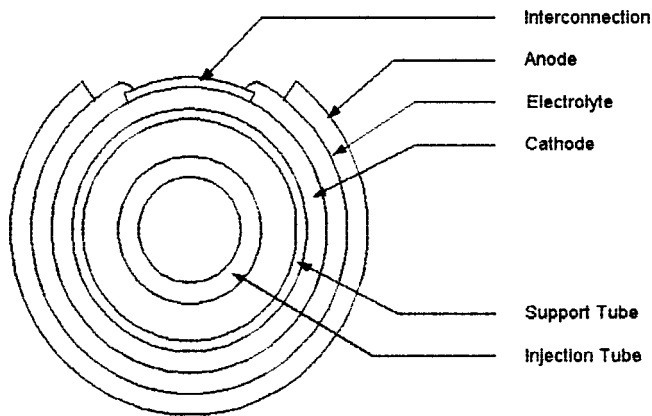

Fig. 2 Cross section of an individual cell ([1])

CO and hydrocarbons such as CH<sub>4</sub> can also be used as fuels in a SOFC. At the high temperatures within the cell, it is feasible for the following reactions to occur:

- 1 the water gas shift reaction:  $\text{CO} + \text{H}_2\text{O} = \text{H}_2 + \text{CO}_2$
- 2 and the steam reforming reaction:  $\text{CH}_4 + \text{H}_2\text{O} = 3\text{H}_2 + \text{CO}$  (in the case of natural gas and in the presence of a suitable catalyst).

The H<sub>2</sub> thus produced is easily oxidized at the anode. The direct oxidation of CO in fuel cells is well established while the direct oxidation of CH<sub>4</sub> has been investigated to a limited extent ([1]). The direct oxidation of CO and CH<sub>4</sub> occurs only at very low steam to carbon ratios. Potential for carbon formation, however, exists at the low steam to carbon ratios. Any sulfur compounds present in the fuel have to be removed prior to use in the cell to a concentration of <0.1 ppmV to avoid poisoning of the (conventional) reformer catalyst.

### Solid Oxide Fuel Cell (SOFC) Hybrid Systems

A fuel-cell-based hybrid cycle consists of combining a fuel cell with a heat engine to maximize the overall system efficiency. One example of such a Hybrid cycle is the SureCell™ system as proposed by Westinghouse and depicted in Fig. 3 ([2]).

The cycle utilizes an intercooled compressor while the discharge air after preheating against the turbine exhaust is provided to the SOFC as its oxidant. Fuel is also preheated in the turbine exhaust, desulfurized, and then supplied to the SOFC as well as the gas turbine combustor(s). The exhaust from the SOFC is supplied to the high-pressure combustor of the gas turbine where additional fuel may be added and combusted by the SOFC exhaust. The exhaust from the combustor enters the high-pressure expander where it is expanded to a pressure that is higher than atmospheric and then supplied to a second combustor where additional fuel is fired. The hot exhaust from the second (low pressure) combustor is then expanded in the low-pressure expander to near atmospheric pressure and then supplied to the heat recovery unit. The power developed by the high pressure and the low-pressure expanders drives the compressors and the electric generator, respectively.

### Existing Analysis Tools

Existing computer-based models for analysis of systems such as power cycles may be divided into two types (1) those developed for simulating chemical process plants (e.g., commercially available Hysis, Aspen, Pro II) and (2) those developed for simulating power plants (e.g., commercially available ThermoFlex and GATE/Cycle). Models in the first category have the capability for predicting the thermodynamic properties of nonideal systems but do not include detailed models for power cycle equipment such as gas turbines and fuel cells. The models in the second category have the capability of modeling gas and steam turbines in detail but not fuel cells nor the capability of predicting the properties of nonideal gases except for pure steam. Thus these models, for ex-

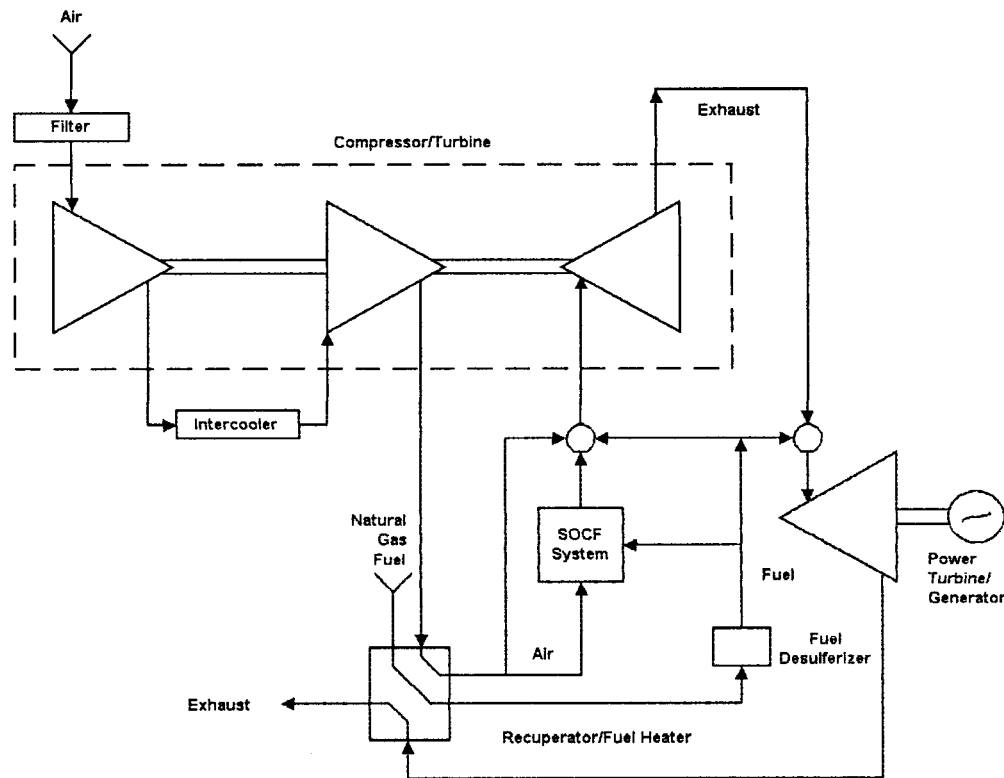

Fig. 3 SureCell™ system as proposed by Westinghouse ([2])

ample, cannot predict the Joule-Thompson cooling of natural gas when its pressure is reduced from typical pipeline pressure (50 bar) to the pressure required by a heavy frame gas turbine which typically operates at a pressure ratio in the neighborhood of 15. Furthermore, with greenhouse gas emissions becoming a more global concern, the proposed recovery and compression of the carbon dioxide to supercritical pressure is becoming a typical specification for disposal in many advanced cycle investigations, requiring the capability of predicting the nonideal behavior of carbon dioxide.

Models in the second category do not include modules for simulating reactors such as a shift reactor in cases where CO<sub>2</sub> removal and capture or production of H<sub>2</sub> for a PAFC or PEMFC is required. Simplified models are included for countercurrent multistage humidification which is being incorporated into advanced Brayton type of power cycles consisting of evaporating water into the working fluid, and for partial oxidation reactor which is utilized to convert a fuel such as coal or heavy fuel oil into synthesis gas suitable as fuel to a fuel cell.

Models for simulating fuel cell based plants have been developed by Ferguson [3], Haynes [4], and Bessette [5] but these models are limited either to systems consisting of ideal gases and pure steam or the models required for simulating many of the unit operations and processes that could make up a hybrid plant are not included such as a detailed gas turbine, a countercurrent multistage humidifier, a shift reactor, and a partial oxidation reactor.

In summary, the requirements for the analysis tools for the evaluation of SOFC fuel cell systems and SOFC hybrid systems performance are

- an SOFC model that accounts for the heat and mass transfer processes occurring within the cell as well as the electrochemistry such that the calculated performance reflects the particular system design conditions such as fuel composition, operating pressure, fuel utilization and geometric parameters such as tube dimensions.
- a gas turbine model that accounts for the changes in the cycle design conditions such as the operating pressure, turbine firing temperature, the fuel and oxidant temperature and composition. The gas turbine model must adjust the required turbine cooling flows or the firing temperature to correspond to changes in the temperature or composition of the working fluid or coolant based on the effective technology parameters that may be estimated from the gas turbine manufacturer's published data, in order to stay within the constraints of the maximum blade metal temperature.
- a humidifier model that accounts for the simultaneous heat and mass transfer rate-controlled processes.
- an equation of state capable of estimating the enthalpy and entropy corrections for nonideality of the gas streams is required in order to handle highly nonideal streams such as natural gas at pipeline pressures, and supercritical CO<sub>2</sub>. A separate property package for steam and water is required (consistent with the ASME steam tables) including correction for the enthalpy of water due to pressure above its saturation pressure.

Thus a need exists for an analysis tool for evaluating tubular SOFC hybrid systems; the following describes the tool that was recently developed for such applications.

## Analytical and Computational Strategy

**Thermodynamic Property Basis.** The Peng-Robinson equation of state ([6]) which is a modification of the van der Waal's equation is utilized to predict the deviations from nonideality of the specific volume, enthalpy and entropy of gases. Empirical correlations developed by Schnackel [7] are used for predicting the specific volume, enthalpy and entropy of pure steam. The properties of saturated water are predicted by empirical equations fitted to the ASME published data.

**Tubular SOFC Model.** An integral model for the heat and mass transfer and the electrochemical processes occurring in the various sections of the cell is developed although the model equations may be applied for zonal analysis of the SOFC when heat flux by conduction in the axial direction may be considered constant and interzonal radiation may be neglected. The integral model minimizes the computational time required to solve the SOFC module and thus the total time required by the computer to solve the entire hybrid plant. Note that a hybrid plant typically includes a number of other equipment modules and furthermore, a number of iterations have to typically occur not only within a module but also between the modules in order to arrive at a converged solution with all the user defined system design parameters satisfied.

The differential equations governing the various processes for a single cell are formulated and simplifying assumptions are made in order to solve these equations analytically. The resulting solutions to these equations are coded into the module. The net AC power output from the stack is estimated by applying an empirical factor to the product of the DC power generated by a single cell and the total number of cells calculated.

**Heat Generation.** The maximum power that may be developed by the cell is given by the Gibbs free energy change for the oxidation reaction of the fuel. However, the irreversibilities within the cell limit the conversion to useful work. The irreversibilities consist of concentration polarizations caused by a build up of reactants or products at the electrodes, activation polarizations that are caused by the sluggishness of the electrochemical reaction speeds and ohmic losses. The voltage drops due to each of these irreversibilities are taken into account. In addition to the heat generated by these irreversibilities, the cell generates heat on a net basis due to the entropy change of the overall H<sub>2</sub> oxidation reaction.

**Solution Strategy.** The solution strategy consists of starting the calculations at one end of the cell where the oxidant leaves the injector tube and enters the annular space between the cathode and the injector tube. For a given set of temperatures for the oxidant and the fuel at this cross section (boundary condition), a temperature drop for the air inside the preheat tube and the ratio of actual current flow to the limiting current flow are assumed. The heat and mass transfer equations are solved from section to section in the radial direction. Each of the heat generation terms due to the irreversibilities and the entropy change is utilized. The net DC electric power generated is calculated by subtracting the total heat generated due to the irreversibilities and those due to entropy change, from the overall enthalpy change for the oxidation reaction of the fuel with molecular oxygen. Next, an energy balance is made and the assumed temperature drop of the air inside the preheat tube is adjusted accordingly. Thus a solution is arrived at iteratively and the resulting voltage is calculated from the power produced and the current flow. Iterations are continued if the voltage calculated does not match the desired voltage by adjusting the ratio of actual current flow to the limiting current flow and repeating the entire iterative process defined above.

**Compressor and Turbine Models.** The outlet conditions from a compressor and expander (including a steam turbine) are calculated assuming an isentropic path and then applying the appropriate efficiency to determine the actual outlet conditions for a given inlet set of conditions. The efficiency is either user defined or is calculated by the computer program using empirical relationships ([8]) in the case of a compressor, while empirical correlations developed by Spencer et al. [9] for each of the sections (high pressure, intermediate pressure, and condensing) may be utilized for the steam turbine, depending on its size.

**Gas Turbine Model.** Two types of gas turbine models are developed, one that may be configured by the user to include multiple compression stages with intercooling between the stages

and multiple expansion stages with reheat (with combustors) between the stages, and the second consisting of a simple cycle (or conventional Brayton cycle) with no intercooling of the compressor or reheat during expansion.

The user defined gas turbine model is configured by utilizing a gas turbine compressor, combustor and gas turbine expander modules. The efficiency of the compressor and expander and the air required for cooling the blades of the turbine as well as its purge air requirements are determined by first calibrating a simple cycle engine based on data published by the gas turbine manufacturer, and then applying adjustments to the values determined for the "base line engine." The program estimates the necessary parameters for the base line engine and the adjusted values for use with the two gas turbine models when the manufacturer's overall gas turbine performance data is inputted.

The compressor and expander efficiencies are adjusted for flow through the compressor or expander. The turbine coolant requirement is adjusted in order to maintain the same metal temperature for the first stage blades of the turbine by utilizing the semi-empirical methodology proposed by El-Masri and Pourkey [10] which consists of modeling a combined convective/film cooled blade as a flat plate and developing nondimensional parameters relating the physical properties of the working fluid and the coolant. The turbine purge requirement is adjusted by maintaining the same velocity as that in the base line engine.

The second model, consisting of the simple cycle gas turbine, assumes that the gas turbine has the same geometry as the gas turbine used for calibrating the engine. The model makes adjustments to the compressor and expander efficiencies as well as the firing temperature and pressure ratio of the gas turbine for variations of flow rates and composition. The pressure ratio adjustment is based on the assumption that the Mach number for the flow in the first stage nozzle of the turbine is at unity ([11]). The firing temperature is adjusted in order to maintain the same metal temperature of the first stage blades as that for the base-line engine since the turbine cooling flows are not controlled.

**Humidifier.** The humidification column is divided into differential diffusional units= $k_x a dV/L$  [12] where  $k_x$  is the mass transfer coefficient on a mass basis,  $a$  is the interfacial area for mass transfer per unit volume,  $dV$  is a volume element for mass and heat transfer of differential thickness in the axial direction of the column per unit cross-sectional area, and  $L$  is the superficial liquid mass velocity (mass flow rate per unit cross-sectional area).

The heat and mass transfer differential equations for change in temperature of the liquid flowing down the column by gravity and the change in temperature of the gas flowing up the column counter-currently to the liquid are determined. A term was introduced to account for the heat transfer due to the sensible heat of the water vapor diffusing into the gas phase which was not included by previous authors. The Lewis analogy is invoked in deriving these equations and it is assumed that the gas and water flow through the humidifier column under plug-flow conditions.

**Reactor Models.** Models for the following reactors are included:

1. shift,
2. reformer, and
3. partial oxidation.

The reactor modules calculate the effluent composition and conditions for a given set of design parameters such as the feed composition and conditions of pressure and temperature, pressure drop through the reactor, and the outlet temperature in the case of an adiabatic reactor, and the required heat transfer rate in the case of a nonadiabatic reactor for a desired outlet temperature.

These calculations are made by solving a set of simultaneous

equations consisting of the elemental balances, energy balance, and the reaction quotients, which represent the approach to equilibrium at the outlet conditions of the reactor.

The thermodynamically independent reactions are for shift reactor:

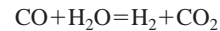

for reformer and partial oxidation reactors:

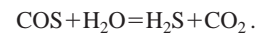
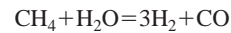
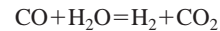

**Balance of Plant Equipment Models.** The balance of plant equipment such as a valve, stream mixer, stream splitter, or divider and separator (of a single component from a stream or liquid water from gas/vapor phase) are modeled for an isenthalpic path. Two types of heat exchangers are available, one in which the outlet temperature may be specified to calculate the heat transfer rate, and the other where the heat transfer rate is specified to calculate the outlet temperature. For a pump, the power required is determined assuming the fluid is incompressible. A pipe module is also included to serve the important function of accounting for pressure and heat losses between the equipment in order to calculate the cycle performance more accurately.

**Integrated Architecture.** The system model or cycle is configured by identifying the desired equipment models and assigning numbers for the streams entering or leaving each of the equipment. The plant may be configured with multiple units of the same type of equipment. Each of the streams entering the plant such as fuel, water, and air is defined by its composition, flow rate, temperature, and pressure while the model predicts all the intermediate streams within the system and the streams leaving the system.

A special module, "controller" is included to define the special design parameters within the system. For example, in order to set the steam-to-carbon ratio in the stream entering the reformer at a predetermined value in order to avoid carbon deposition on the catalyst, the controller is included in the system definition to check if this ratio is being satisfied, as well as to make necessary changes in order to satisfy the design criteria. The controlled variable (dependent variable) and the controlling variable (independent variable) which has to be changed by the controller in order to meet a desired design criterion are identified. The type of variable (temperature, pressure, flow rate, steam-to-carbon ratio, etc.) and the stream or equipment containing these variables are also identified for the controller. The controller then forces the program to iterate while adjusting the controlling variable till the desired result is achieved. The controller may be used multiple times for defining different system design parameters.

In summary, the steps involved in developing the overall system performance are

- 1 a system model or cycle is configured by identifying desired equipment (graphical interface is currently not available).
- 2 assigning numbers for streams entering or leaving each equipment.
- 3 defining streams entering a system such as fuel, water, and air by specifying composition, flow rate, temperature, and pressure.
- 4 the "controller" is included to define cycle design parameters/targets within the system.
- 5 the model predicts intermediate streams within the system, streams leaving the system, power consumption (of pumps, compressors), power generation (of SOFC, gas turbine, turbo-expander), heat transferred in each of the heat exchangers.

The model also predicts the size of the SOFC (number of tubes for a specified tube diameter and length) and dimensions of the humidifier column (diameter and packed height). In this manner, systems may be identified that utilize these equipment having practical or realistic sizes.

## Results and Discussions

A comparison of performance predictions made by the SOFC model (shown as discrete points) with curves published by Westinghouse ([13]) is presented graphically in Fig. 4. The bottom curve corresponds to an operating pressure of 1 atm while the top curve corresponds to an operating pressure of 10 atm. The tube length is 150 cm with 2.2 cm outside diameter. The fuel consists of a mixture of 89 mole percent hydrogen and 11 mole percent water vapor. Fuel utilization is held constant at 85 percent. The air used in the SOFC is six times the stoichiometric requirement.

As can be seen, the predictions made by the model are in agreement with the Westinghouse values. The curves are characteristic of fuel cells, where the power initially increases as the current also increases (since the oxidant and fuel flow to the tube are increased), reaches a maximum value and then decreases. The power decreases because the losses which increase with the current density become large enough to more than offset the gain made by the increase in the fuel and oxidant throughput.

A comparison of the single zone model predictions for the typical 85 percent fuel utilization with those obtained by applying the model with the cell subdivided into two zones in the axial direction, each with the same degree of fuel utilization (each at 42.5 percent utilization) is presented in Table 1 for a single tube. The

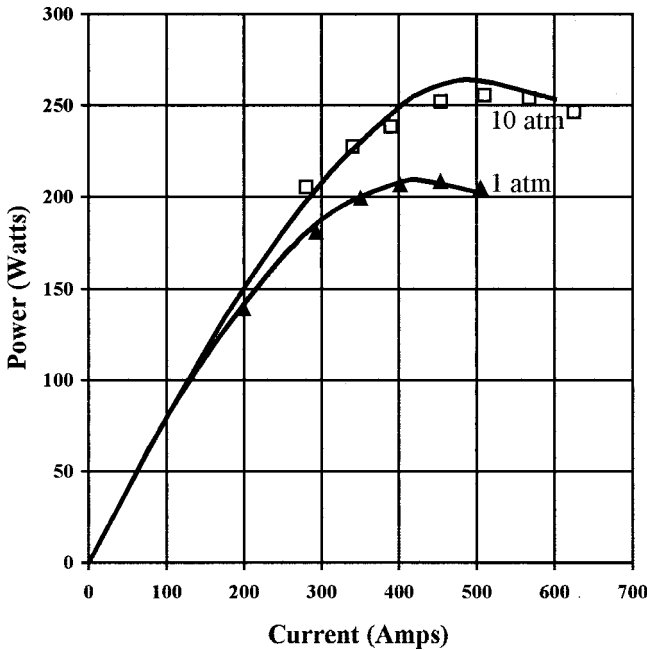

Fig. 4 Comparison between predicted performance and Westinghouse values

Table 1 Comparison of single and two-zone model predictions

	Single-Zone Model	Two-Zone Model
current density, mA/cm <sup>2</sup>	310.0	311.2
power, Watts	243	242.8
cell length, cm	185.1	186.0

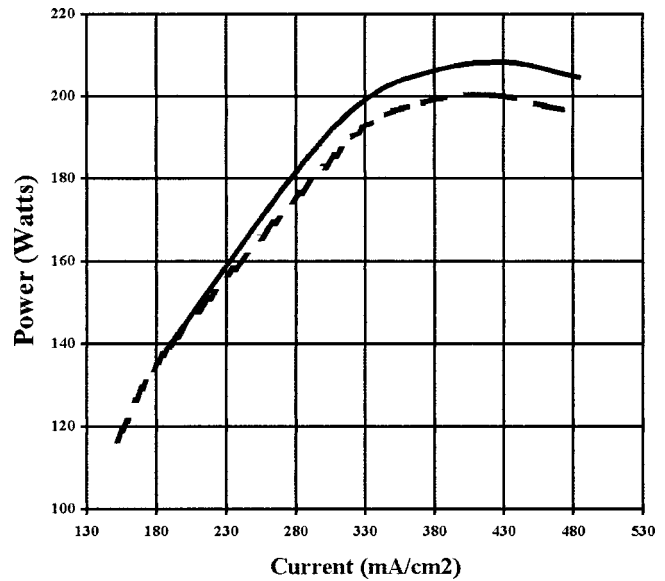

Fig. 5 Performance of SOFC with CO versus H<sub>2</sub> as fuel

current and power are essentially the same for the two cases while the cell length is within 0.5 percent showing that a single-zone (integral) model suffices.

Figure 5 compares the performance of the SOFC with CO versus H<sub>2</sub> as the fuel at 1 atm operating pressure with a mixture of 89 mole percent CO and 11 mole percent CO<sub>2</sub> versus the mixture of 89 mole percent H<sub>2</sub> and 11 mole percent H<sub>2</sub>O. By choosing a mixture of CO and CO<sub>2</sub> the direct oxidation of CO may be compared with that of H<sub>2</sub> (ignoring the carbon formation potential for the CO fuel for this comparison). The current density and power produced by the cell are lower with CO because (1) the Gibbs free energy for the oxidation of CO is lower than that for H<sub>2</sub> at the operating temperature of the cell and (2) the diffusivity of CO is lower than that of H<sub>2</sub> which increases the anode concentration polarization.

Figure 6 shows the effect of pre-reforming (outside the cell) versus reforming the CH<sub>4</sub> fuel within the cell, i.e., assuming the anode section of the cell contains a reforming catalyst. When fuel reforming occurs within the cell, the heat released within the cell due to the various irreversibilities discussed earlier is absorbed directly by the endothermic reforming reactions while in the external reforming case, the heat rejected by the cell in the exhaust gas is utilized for the reforming reaction.

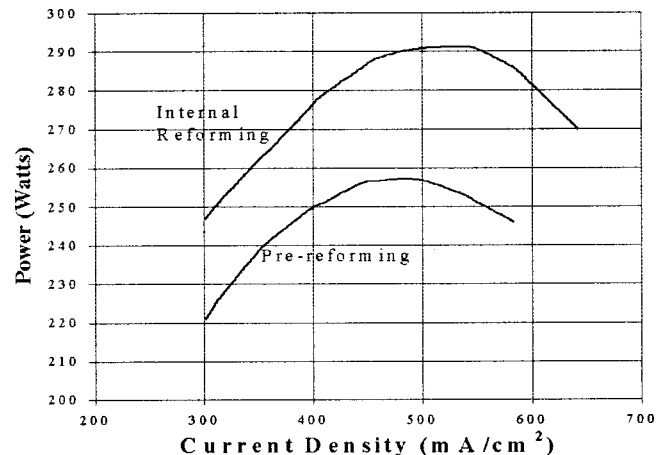

Fig. 6 Effect of reforming the fuel within the cell

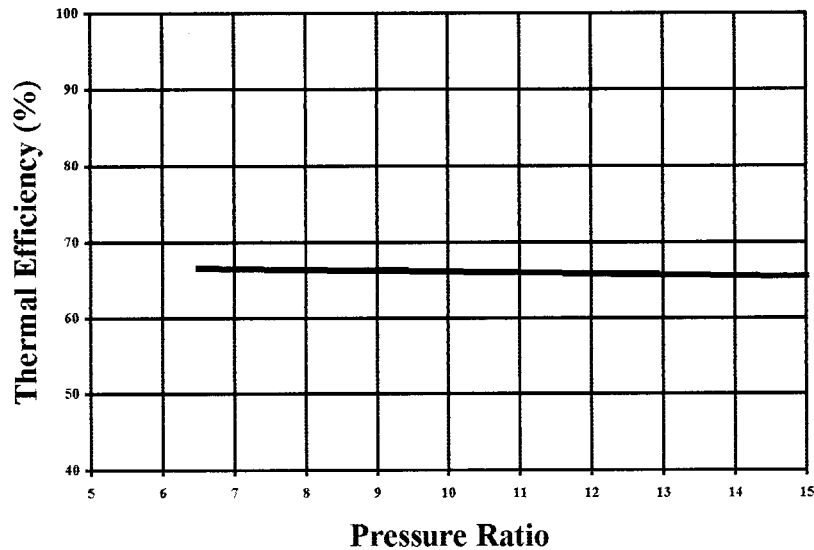

Fig. 7 Effect of pressure ratio on the performance of the SureCell™ hybrid cycle

The extent of reforming within the external reformer is limited by the concentration of water vapor contained in the fuel while in the case of internal reforming, the  $H_2O$  formed by the oxidation of the  $H_2$  becomes available for continuing the reforming reaction within the internal reformer. Thus, the amount of  $CH_4$  utilization is limited by the concentration of water vapor present in the fuel gas in the case of the external reformer. The cell performance is thus poorer for the external reformer case when limited amount of  $H_2O$  is added to the fuel.

Thus, internal reforming has the potential to minimize water consumption (or amount of recycle of the depleted fuel which may be used for water vapor addition to the fuel) as long as suitable reforming catalysts are developed that avoid carbon formation at low water vapor to carbon ratios.

### Application of Methodology

An application of the system model to analyze the pressure dependence of the hybrid cycle configuration depicted in Fig. 3 is presented graphically in Fig. 7.

The entire air leaving the high pressure compressor was provided to the SOFC after preheating in the recuperator with an effectiveness of 90 percent. The individual cell voltage was maintained at 0.62 V. A portion of the depleted fuel was combined with the desulfurized natural gas in order to provide the water vapor required by the reformer within the SOFC. The high pressure turbine inlet temperature was maintained at  $861^\circ C$ , while the inlet temperature of the low pressure turbine was maintained at  $863^\circ C$  ([2]) by adjusting the fuel flow. The isentropic efficiencies of the compressors and the expanders were held at 85 percent and 87 percent, respectively.

The thermal efficiency of the cycle was found to be quite insensitive to the pressure ratio (ratio of SOFC inlet air pressure to low-pressure compressor inlet air pressure), increasing slightly with a decrease in pressure ratio in the range investigated; from 65.5 percent to 66.6 percent on a lower calorific value of the fuel as the pressure ratio was decreased from 15 to 6.5. As the cycle pressure ratio is reduced, the exhaust temperature from the low pressure turbine increases which in turn increases the temperature of the preheated air supplied to the SOFC. This increase in temperature more than offsets the decrease in efficiency of the SOFC operating at a lower pressure in the range of pressure ratios investigated. Furthermore, the irreversibilities in the low-pressure combustor are reduced at the lower pressure ratio because the tem-

perature of the oxidant stream entering this combustor increases as the expansion ratio of the high-pressure turbine decreases. Also, the contribution to exergy loss by the intercooler is reduced as the cycle pressure ratio is decreased since less heat is rejected in the intercooler as the compression ratio of the low-pressure compressor is reduced.

Selection of the optimum cycle pressure ratio requires performing an economic tradeoff between the calculated thermal efficiency of the cycle and installed cost of the equipment whose specifications may be established by this systems analysis tool. Note that as the pressure ratio is increased, the equipment becomes more compact.

### Summary and Conclusions

The analysis capabilities required to perform tubular SOFC based hybrid cycles include an analytical model for the tubular SOFC as well as the secondary equipment required to analyze a hybrid power plant such as a gas turbine, reformer or partial oxidation reactor, shift reactor, humidifier, steam turbines, compressor, gas expander, heat exchangers, and pump. In addition to these equipment models, modules for functions such as separating a component from a stream, splitting a stream or combining streams and "controller" to automatically iterate in order to meet the desired design criteria are included. Another important capability that is included is to be able to arrange the various components or modules as defined by the user in order to configure different hybrid systems. With the help of this tool, it is possible to configure various hybrid cycle configurations in order to identify the more promising ones for further research and development.

Thus, the model may be used by cycle analysts from industry (e.g., equipment manufacturers, Engineering and Consulting firms, electric utility companies) for verifying performance of proposed cycles, as well as for developing new cycles. Current work is directed towards this activity of developing and identifying new tubular SOFC based hybrid cycles utilizing this tool. The ultimate goals for the capabilities of this tool are to have a user graphical interface for configuring the cycle and to have plant cost estimating capability.

Analysis of the hybrid cycle as originally proposed by Westinghouse (SureCell™) indicates that the thermal efficiency of the cycle is quite insensitive to the pressure ratio, increasing from 65.5 percent to 66.6 percent on a lower calorific value of the fuel as the pressure ratio decreases from 15 to 6.5.

## References

- [1] Hirschenhofer, J. H. et al., 1950, *Fuel Cell Handbook* (Revision 3), U.S. Department of Energy (DE94004072), Jan.
- [2] Bevc, F. P., and Parker, W. G., 1995, "SureCell™ Integrated Solid Oxide Fuel Cell Power Plants for Distributed Power Applications," *PowerGen 1995*, PennWell, Tulsa, OK.
- [3] Ferguson, J. R., 1989, "Heat and Mass Transfer Aspects of SOFC Assemblies and Systems," *IEA Natural Gas Fueled Solid Oxide Fuel Cells and Systems*, Proceedings of Charmey Workshop, July 2–6, Swiss Federal Office of Energy, Berne.
- [4] Haynes, C. L., 1999 "Simulation of Tubular Solid Oxide Fuel Cell Behavior for Integration Into Gas Turbine Cycles," Ph.D. thesis, Georgia Institute of Technology, July.
- [5] Bessette, N. F., 1994, "Modeling and Simulation for Solid Oxide Fuel Cell Power Systems," Ph. D. thesis, Georgia Institute of Technology.
- [6] Peng, D., and Robinson, D. B., 1976, "A New Two-Constant Equation of State," *Ind. Eng. Chem. Fundam.*, **116**, No. 1, pp. 59–64.
- [7] Schnackel, H. C., 1958, "Formulations for the Thermodynamic Properties of Steam and Water," *Trans. ASME*, **80**, pp. 959–966.
- [8] Gas Research Institute Report, 1993, "Evaluation of Advanced Gas Turbine Cycles," Report No. GRI-93/0250, Aug.
- [9] Spencer, R. C., et al., 1974, "A Method for Predicting the Performance of Steam Turbine-Generators," *General Electric Technical Bulletin GER-2007C*, July.
- [10] El-Masri, M. A., and Pourkey, F., 1986, "Prediction of Cooling Flow Requirements for Advanced Utility Gas Turbines Part 1: Analysis and Scaling of the Effectiveness Curve," presented at ASME Winter Annual Meeting.
- [11] Electric Power Research Institute Report, 1983, "Gas Turbine Evaluation (GATE) Computer Program," Report No. AP-2871-CCM, Feb.
- [12] Kern, D. Q., 1950, *Process Heat Transfer*, McGraw-Hill, New York, pp. 563–621.
- [13] Bessette, N. F., and George, R. A., 1996, *Performance and Reliability of Westinghouse's Air Electrode Supported Solid Oxide Fuel Cell at Atmospheric and Elevated Pressures*, Mar., Denki Nagaku.