

# Lawrence Berkeley National Laboratory

## LBL Publications

### Title

Integrating diagnostics and model-based optimization

### Permalink

<https://escholarship.org/uc/item/7dx7r29k>

### Authors

Granderson, Jessica

Lin, Guanjing

Blum, David

et al.

### Publication Date

2019

### DOI

10.1016/j.enbuild.2018.10.015

Peer reviewed



# Lawrence Berkeley National Laboratory

## Integrating Diagnostics and Model-based Optimization

Jessica Granderson

Guanjing Lin

David Blum

Janie Page

Michael Spears

Mary Ann Piette

Lawrence Berkeley National Laboratory

Energy Technologies Area

October 2018

Please cite as:

Granderson, J., Lin, G., Blum, D., Page, J., Spears, M., and Piette, M.A., 2018. Integrating Diagnostic and Model-based Optimization. *Energy and Buildings*. DOI 10.1016/j.enbuild.2018.10.015

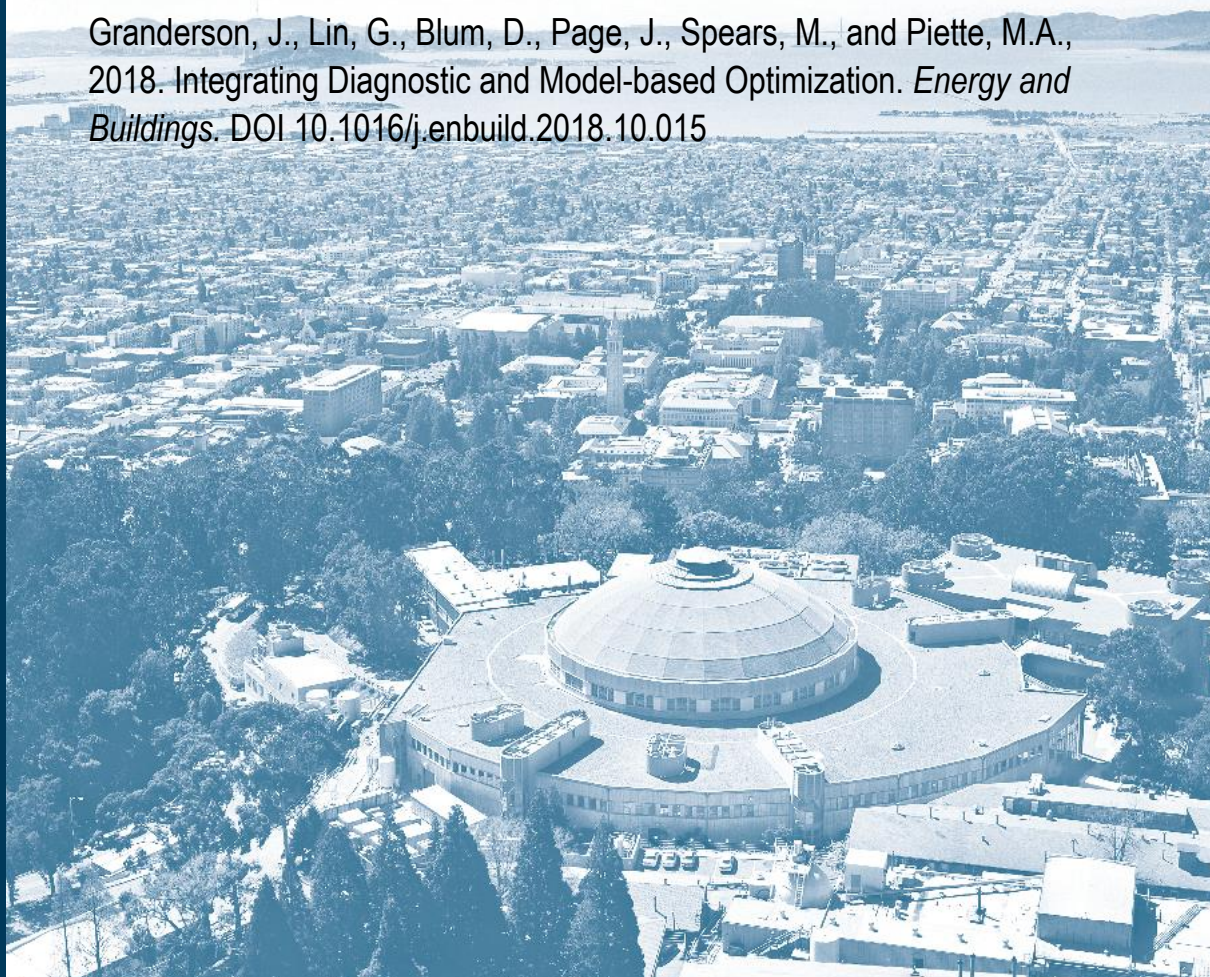

Disclaimer:

This document was prepared as an account of work sponsored by the United States Government. While this document is believed to contain correct information, neither the United States Government nor any agency thereof, nor the Regents of the University of California, nor any of their employees, makes any warranty, express or implied, or assumes any legal responsibility for the accuracy, completeness, or usefulness of any information, apparatus, product, or process disclosed, or represents that its use would not infringe privately owned rights. Reference herein to any specific commercial product, process, or service by its trade name, trademark, manufacturer, or otherwise, does not necessarily constitute or imply its endorsement, recommendation, or favoring by the United States Government or any agency thereof, or the Regents of the University of California. The views and opinions of authors expressed herein do not necessarily state or reflect those of the United States Government or any agency thereof or the Regents of the University of California.

# Integrating Diagnostics and Model-based Optimization

Jessica Granderson, Guanjing Lin, David Blum, Janie Page, Michael Spears, Mary Ann Piette  
Lawrence Berkeley National Laboratory

## Abstract

Energy Management and Information Systems are a family of analytics technologies that include energy information systems, fault detection and diagnostics (FDD), and automated system optimization tools. Such systems have the potential to enable buildings to meet energy management goals of reducing total energy consumption and cost. Most current market offerings use data-driven and rule-based analytics. However, the use of physics-based models in the analytics offers potential improvements by providing an accurate estimation of outputs based on representation of the physical principles governing the building system behaviors. This also permits the use of design stage models to inform commissioning and operation.

This paper describes the development and testing of a hybrid data-driven and physics model-based operational tool for energy efficiency in central cooling plants. The tool offers FDD functionality, setpoint optimization, and visualization of key performance parameters. It was demonstrated at a university campus in the mixed-humid ASHRAE Climate Zone 4A. Key performance metrics that were analyzed include plant electricity use reduction, plant model calibration, and system economics. Annual simulations indicate the tool can provide electricity savings of greater than 10% for approximately six months of the year, mainly during the winter season when wet bulb temperatures are low, though only 1.38% savings for the entire year. Additionally, over a 4-day period in April, recommended optimal setpoints were implemented, resulting in 17% savings versus metered baseline consumption. With respect to model calibration, the difference between model-predicted and measured parameters was less than 10% for 90% of data points acquired for three of six chillers, and for each ten cooling towers. Finally, the tool users reported that satisfaction with the capabilities was equal to or better than that with the preexisting BAS system.

*Keywords:* Energy management and information systems (EMIS); fault detection and diagnostics (FDD); optimization; Modelica; physics-based modeling; central cooling plant.

## Introduction

The building sector is widely recognized as a significant consumer of energy (IEA 2017). Commercial and residential buildings, together, account for 41% of primary energy consumption in the United States and 40% in the European Union (U.S. DOE 2011, Friedrich 2013). Existing buildings are often not properly commissioned for efficient operations, and performance degrades when retrofits, faults and other improvements are not appropriately monitored over time (Fernandez 2017, Liu 2003, Brambley 2009). Among the technologies to save building energy and utility costs, analytics software or Energy Management and Information Systems

(EMIS) hold promise to advance building operations and are increasingly used by energy managers, building owners, and operators.

EMIS are a family of analytics technologies including energy information system (EIS), fault detection and diagnostics (FDD), and automated system optimization (ASO) tools. Energy information systems analyze and display whole-building, system-level, or equipment-level energy use. Fault detection and diagnosis systems use building operational data from the control system to identify the presence of faults and isolate their possible root causes. Automated system optimization tools are newer to the market than EIS and FDD. They use data from the control system to predict optimal setpoints to minimize system energy consumption or costs.

EMIS enable cost-effectively savings on the order of ten to twenty percent (Granderson 2016; Henderson 2013; Kramer 2017). For example, three office buildings in Washington DC, U.S., implemented an EIS and achieved a 13% reduction in electricity use (Henderson 2013). Microsoft, which maintains the largest contiguous corporate campus in the US, has deployed an FDD system for building-level HVAC operations, and have saved over 18% in electricity consumption at their Puget Sound campus with rapid payback (Fernandes 2018, Smith 2011). The United States General Services Administration (GSA) proving ground program has demonstrated a chiller plant ASO technology in 2016. This technology determines optimized chilled water loop pressure setpoint for improving plant efficiency, and achieved 35% savings of the projected baseline at the demonstration site (Hail 2016). Since then, GSA has deployed the technology in another eight government buildings (U.S. GSA 2017).

Most of EMIS analytic technologies on the market use rule-based or data-driven approaches to provide insights to building operators (Granderson 2017). In contrast, physics-based modeling uses first-principles and engineering models (e.g., efficiency curves) to characterize system and building behaviors. Integration of physics-based models to complement data-driven approaches has the potential for advancement. First, physics-based models effectively address the physical principles governing the building system behaviors and provide an accurate estimation of outputs when they are well formulated. Second, they allow the use of models from the design stage to predict the expected performance during commissioning and operation. Historically, these physics-based approaches (e.g. EnergyPlus, TRNSYS), have been used in the design phase of the building life cycle or in retrofit analyses, and not in the operational phase. Whereas empirical data-driven analytics permit assessment of operations based on actual prior system performance, physics-based approaches also enable assessment relative to design intent, and underlying physical principles. Physics-based models can be used to automate the detection of system or component faults, and to identify optimal control strategies to minimize system energy use.

The use of hybrid data-driven and model-based approaches for operational tools that conduct continuous fault detection and energy use optimization is largely still the domain of exploratory research. Pang (2012) developed EnergyPlus physics-based models to identify whole-building level operational energy waste. Lee (2007) and Lin (2015) examined the use of the ASHRAE

Simplified Energy Analysis Procedure for fault detection at the whole-building level. Greensfelder (2011) used TRNSYS building models to study optimal zone setpoint temperatures in the presence of real-time electricity pricing to minimize energy cost. May-Ostendorp (2011) used EnergyPlus building models to study optimal window operation in mixed-mode buildings to minimize cooling energy consumption. Corbin (2013) proposes a real-time optimization environment utilizing an EnergyPlus building model. Coffey (2010) developed a framework for MPC using GenOpt (Wetter 2001) and demonstrated it in simulation using a TRNSYS model for optimizing zone temperature setpoint setbacks for demand response.

Considering that there are relatively few studies related to on-line chiller plant control to optimize efficiency using physics-based approaches, this work aimed to develop and test a hybrid data-driven and physics model-based operational tool for energy efficiency in central cooling plants. The tool offers FDD functionality, setpoint optimization, and visualization of key performance parameters for a campus chilled water plant. This paper presents the development of the tool, called PlantInsight, assessment of its performance, and feedback from operators.

## **2. Technology Development and Implementation**

PlantInsight is an open source tool that is made up of three primary components: a web-based user interface, an analytics backend, and database. The architecture of these components is described in more detail in Section 2.3. The analytics backend provides algorithms for FDD and ASO. FDD is provided for three types of faults: fan cycling, chiller cycling, and poor chiller efficiency. ASO provides analysis of optimal condenser water setpoint temperatures to minimize plant energy consumption. A calibrated simulation model is used in the algorithms to identify poor chiller efficiency, and optimal condenser water temperature, while the cycling faults are identified using purely data-driven models. In addition, the tool offers visualization for operators to track key parameters such as cooling plant load and chilled water loop temperature.

### **2.1 Model Construction and Calibration**

The physics-based modeling approaches that underlie PlantInsight's optimization and efficiency diagnostics are built using the Modelica language specification (Wetter 2014) and Functional Mockup Interface (FMI) standard (Blochwitz 2011), each of which are open standards. Modelica is an equation-based, object-oriented programming language for the modeling and simulation of physical systems, for which there is a component library for simulating building systems, called the Modelica Buildings Library (Wetter 2014). FMI is a standard way of packaging and interfacing physical models to enable exchange and co-simulation among different tools.

The Modelica models that simulate the operation of the central cooling plant were developed using information from design specifications, nameplate data, drawings, and trend-log data. Component models for chillers, pumps, and cooling towers were taken from the Modelica Buildings Library and parameterized using specification and nameplate data. These component models were combined to form plant-level models of the two central plants at the implementation site. Finally, control sequence models were embedded into each plant model. Figure 1 illustrates a plant model, where solid blue lines represent the water pipes and the dashed lines are the paths for control signals and other inputs for the model, such as weather

data and plant cooling load. Once constructed, the chiller and cooling tower models were calibrated to operational data.

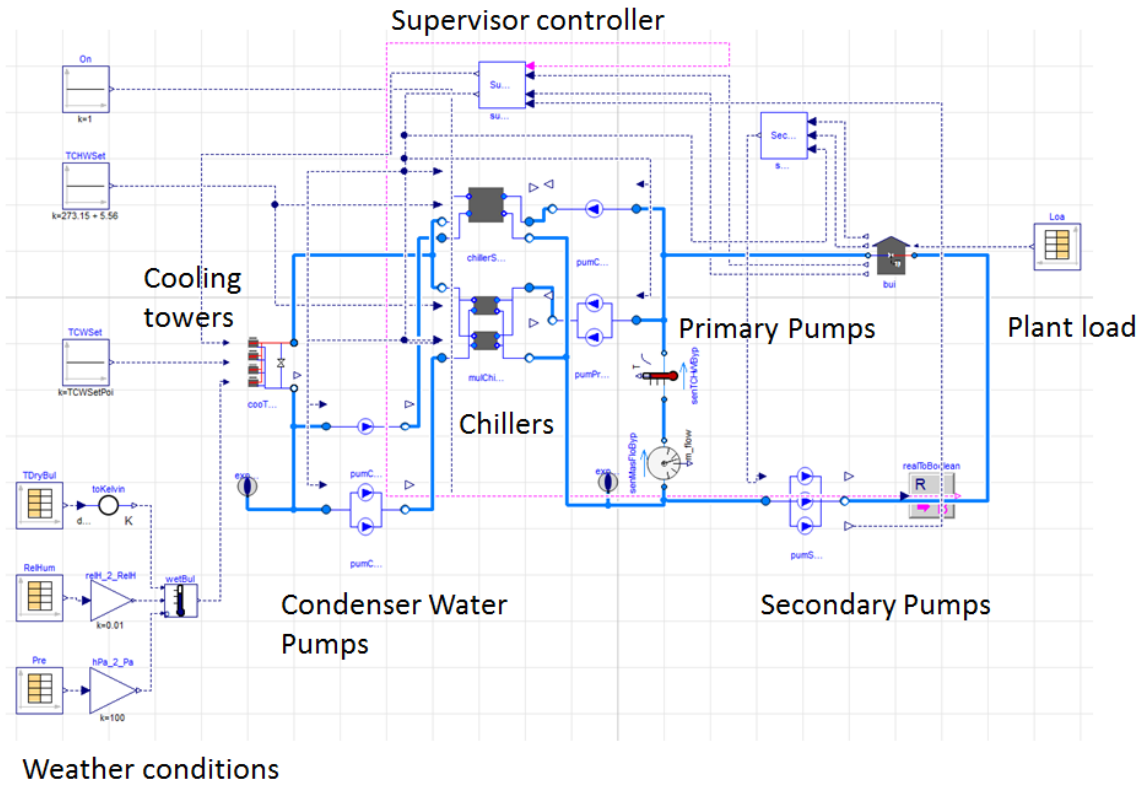

Figure 1. Diagram of the system-level Modelica model for a cooling plant

## 2.2 Optimization and FDD Algorithms

The optimization algorithm determines the most effective cooling tower condenser water temperature setpoint for the next day at which the total energy consumption of the chillers and the cooling towers is minimized. The plant system model was run to predict energy consumption under different condenser water setpoints for the predicted cooling load. Optimization constraints, such as high and low condenser water setpoint limits, were also incorporated into the model. As with the calibration activity, GenOpt was used as the optimization engine. In the configuration of the PlantInsight tool, the optimization period was defined as one day, as recommended by plant staff. The full steps of the optimization routine are (1) predict plant cooling load and (2) find the optimal condenser water temperature setpoint.

### (1) Predict Plant Cooling Load

To predict plant cooling load, we used a regression model that uses a linear combination of a bias, minute, hour, outside air temperature, and day of week. The coefficients of the linear combination are trained by linear least squares on the previous year's data. Different coefficients are trained for each month. To predict the load for a given time, we obtained the forecasted outside air temperature from Weather Underground ([www.wunderground.com](http://www.wunderground.com)) and



used that, along with the prediction time and coefficients from the appropriate month, to compute the plant load. The total predicted load was then split into loads for the main and secondary plants (described in Section 2.5), using a piecewise linear approximation based on historic data from the plant indicating the ratio of primary plant load to total campus load.

## (2) Optimize Condenser Water Temperature Setpoint

The optimal condenser water setpoint was determined by solving the optimization problem defined in Equation 1 below (Huang 2014). It was assumed that all of the cooling towers for a given plant are controlled by the same condenser water setpoint. Since the change of the condenser water setpoint does not impact pump operation, the optimization equation does not include the pump energy consumption.

$$\min \left( E \Big|_{t_0}^{t_0 + \Delta t} \right) = \min \left( \int_{t_0}^{t_0 + \Delta t} (P_{ch}(t) + P_{tw}(t)) dt \right) \text{ for } t \in [t_0, t_0 + \Delta t)$$

$$\text{with } P_{ch}(t) = f(T_{ch,ent}(t), Q^P(t), \vec{S}_{ch}(t))$$

$$\text{and } P_{tw}(t) = f(T_{wb}^P(t), T_{cw,set}(t_0), T_{cw,lea}(t), \vec{S}_{tw}(t))$$

$$\text{such that } T_{cw,set,L} \leq T_{cw,set}(t_0) \leq T_{cw,set,H} \quad (1)$$

In these equations,  $E|_{t_0}^{t_0 + \Delta t}$  is the total energy consumption of the chillers and cooling towers during the optimization period  $[t_0, t_0 + \Delta t)$ ,  $P_{ch}$  is the power of chillers, while  $P_{tw}$  is the power of the cooling towers,  $T_{ch,ent}$  is the entering chilled water temperature (returning from the campus),  $T_{cw,set}$  is the condenser water setpoint,  $T_{cw,lea}$  is the leaving condenser water temperature of the cooling towers,  $Q^P$  is the predicted cooling load,  $T_{wb}^P$  is the predicted wet bulb temperature from a weather forecast,  $\vec{S}$  is the state vector of the system (e.g., equipment operating status and temperature of water leaving the chiller condenser and evaporator), and  $T_{cw,set,L}$  and  $T_{cw,set,H}$  are the low and high limits of the condenser water setpoint during  $[t_0, t_0 + \Delta t)$ .

The Modelica plant system models are used to calculate  $E|_{t_0}^{t_0 + \Delta t}$ , with forecasted plant loads, outside air dry bulb temperature, outside air relative humidity, outside barometric pressure, and condenser water setpoint as inputs for each time interval over the time horizon of interest. GenOpt is used to solve the optimization problem by varying the condenser setpoint temperature for each time interval specified to find the minimum energy consumption over the time horizon. Specifically, the Hooke-Jeeves Pattern Search algorithm is used (Polak 1997). The minimum condenser water setpoint is either 16°C, as specified by the plant operators, or 4°C higher than the minimum outside wet bulb temperature forecasted over the time horizon. This 4°C temperature difference limit is to ensure that the condenser setpoint temperature is achievable with a reasonable tower approach. The maximum condenser water setpoint is 28°C as determined by the plant operators.



Two types of FDD algorithms are implemented in the tool. The first is the detection of cycling faults in the cooling tower fans and chiller compressors. This algorithm uses fan and compressor power data to count the number of on/off cycles within a specified period of time. A fault is flagged if this number is greater than a threshold defined by plant operators. The second is identifying efficiency faults in the chiller. Poor chiller efficiency is determined by comparing model-predicted COP with that estimated from measured data. Described in detail in Bonvini (2014), the FDD algorithm is based on an advanced Bayesian nonlinear state estimation technique called Unscented Kalman Filtering (UKF) that estimates system states and parameters based on measured data and a model of the system (Julier 1996). Detecting poor chiller efficiency for a given time period occurs by first identifying steady-state operating periods, then estimating a COP based on the measured data using the UKF, comparing the estimated value with the expected value from the model and flagging if faulty, and aggregating faulty intervals into faulty periods.

### **2.3 Architecture Definition**

PlantInsight is written in Python 2.7, and consists of three main components: the Django web framework, the model simulation and optimization EstimationPy Python packages, and a PostgreSQL relational database. The Django web framework serves the web pages and API calls, runs the data update routines to calculate derived data points, runs the models, and runs the FDD/optimization algorithms. Within these algorithms, model simulations are run by Dymola dymosim files, optimizations are run by GenOpt, and fault detection and diagnostics use EstimationPy. Dymola is a Modelica development, compiling, and simulation program; GenOpt, is an optimization tool for building energy simulation programs; and EstimationPy is a Python package used for state and parameter estimation of dynamic systems that conform to the Functional Mockup Interface (FMI) standard.

The PlantInsight data originates from a BAS historian database running Microsoft SQL Server located at the cooling plant site. A program was written in Java 8 to copy the data from the USNA SQL Server database to the remote PlantInsight PostgreSQL database. The program was installed on an operator kiosk at USNA and scheduled to run multiple times a day. Automated routines on the PlantInsight system read in the new data, update its derived data points, run the models, run the FDD/optimization algorithms, and update the results on the GUI. The user accesses the tool through a browser-based JavaScript graphical front-end application that interacts with the back-end via a representational state transfer (REST) API.

### **2.4 Graphical User Interface (GUI) Development**

To ensure that the tool would be of maximum utility to plant operators, design feedback was obtained iteratively, throughout development. Figure 2 shows the landing page of the tool. In the plot, the total load on both plants (tons) is overlaid with the load from each plant individually. The landing page plots can be toggled to plant efficiency (kilowatts [kW]/ton) as well as the load and weather forecast for the next 24 hours. Above the plot, the total cost of operations, total consumption, maximum load, and number of current faults are summarized in key performance indicator (KPI) tiles. The landing page also shows runtime summaries and fault summaries.

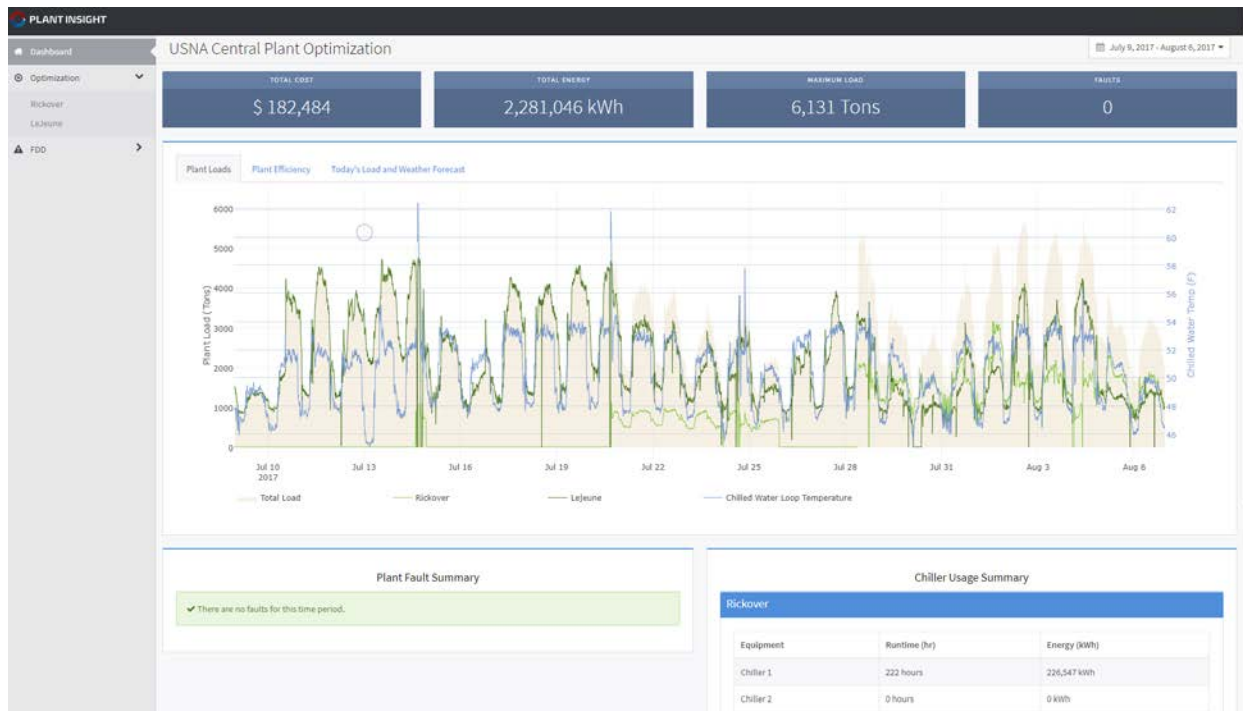

**Figure 2. Screenshot of the landing page of the PlantInsight tool**

Figure 3 shows the condenser water temperature setpoint optimization features in the tool. In the upper plot, the model-determined optimal setpoint for the upcoming day is shown along with the (constant) conventional actual setpoint. The forecasted wet bulb temperature is also plotted. In the lower plot, the actual measured power (orange) and the predicted power that would have been consumed under the model-determined optimal condenser water temperature setpoint (green) is shown for a historical date.

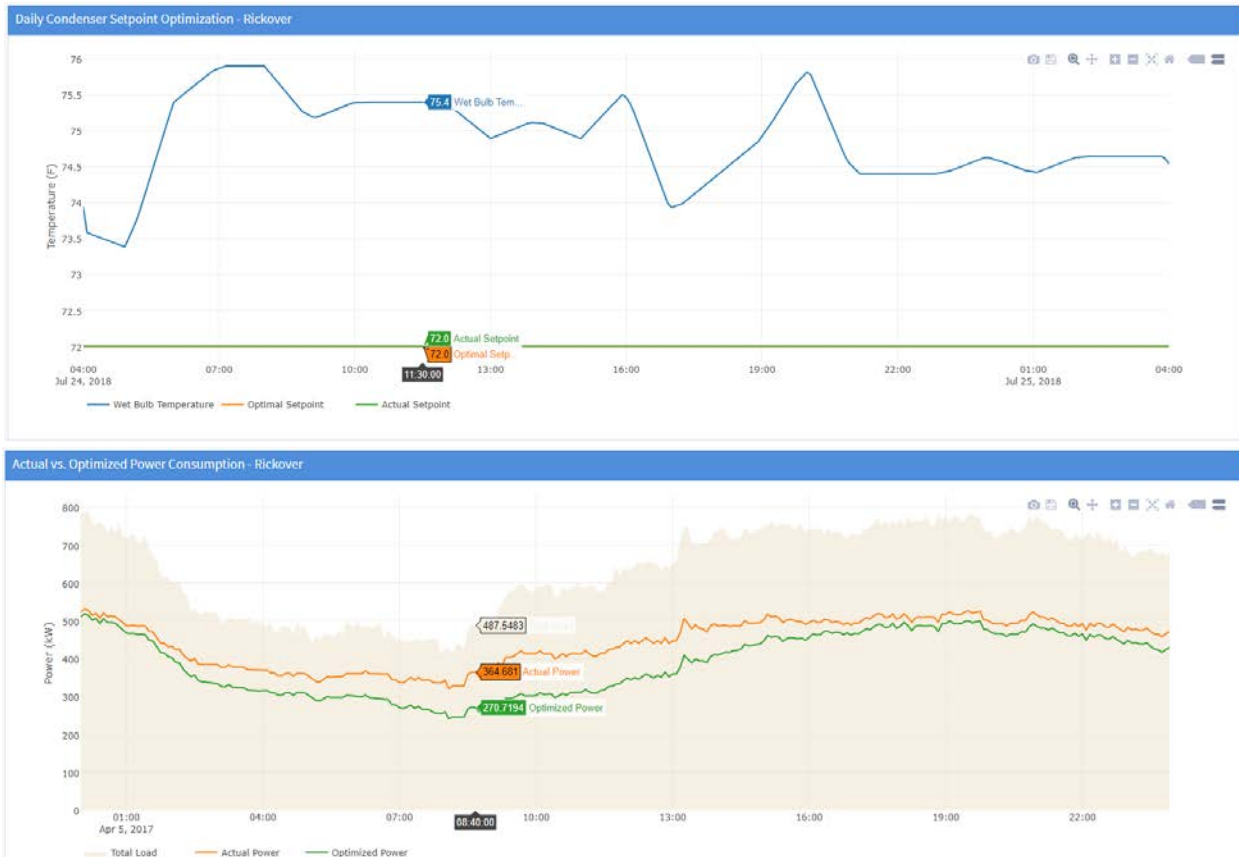

**Figure 3. Screenshots of the condenser water temperature setpoint optimization features in PlantInsight: (Top) Optimal and conventional condenser water setpoints with predicted wet bulb temperature. (Bottom) Measured and predicted optimal power with total plant cooling load.**

## 2.5 Implementation

PlantInsight was demonstrated at a large university campus in the mid atlantic region of the US in the mixed-humid ASHRAE Climate Zone 4A. The technology was implemented across the two central plants that serve the campus-wide chilled water (CHW) loop. As reported by the site, these plants serve approximately 1.8M sf of floor area across the buildings that host the majority of campus academic functions. The main plant, which is used for the majority of the year, contains two 1,250-ton chillers, one 2500-ton chiller, and four two-cell cooling towers. The secondary plant contains three 2,500-ton chillers, and three two-cell cooling towers.

The central chilled water loop is operated in a primary/secondary pumping arrangement with each plant. Variable frequency drives are outfitted on each cooling tower fan and secondary chilled water loop pump. The primary loop pumps are operated as follows. Each pump is associated to a specific chiller and operates at nominal speed if the chiller is designated to turn on. One backup pump is available for chiller during operation. The pumps are staged based on minimum runtime. The secondary loop pumps each have variable frequency drives and are controlled to maintain the prescribed differential pressure setpoint across the campus loop. The condenser pumps are operated similarly to the primary pumps.

The cooling plant is operated to provide campus loop chilled water at 5.6°C +/- 1.1°C. Each plant is operated in a seasonal configuration. Cooling towers are staged on/off according to minimum runtime and to maintain a nominal condenser water temperature of 22.2°C +/- 1.1°C (adjustable). Cooling tower fan speeds are modulated to maintain fine control of the setpoint. Note that this condenser water setpoint is the optimization variable of interest, as described in Section 2.2.

### 3. Assessment Methodology

Three primary objectives were established and used to assess the performance of the PlantInsight technology. These objectives and their associated metrics, data requirements, and performance targets are summarized in Table 1.

**Table 1. PlantInsight performance objectives**

<b>Performance Objective</b>	<b>Metric</b>	<b>Data Requirements</b>	<b>Performance Target</b>
Reduced Central Plant Electricity Use	Annual energy use, normalized for weather (kWh/year)	Plant energy data, and independent variables such as outside air temperature and relative humidity	At least 10% reduction compared to baseline cooling plant energy use
Central Plant Model Calibration	Difference between model prediction and measurement	Plant operational parameters, e.g., compressor status, flow rates, temperatures, weather, fan speed, etc.	Difference between model-predicted and measured parameters less than 10% for 90% of data points
System Economics	Simple payback for technology use	Costs: sensor hardware; hardware and software installation; model creating calibration; model and software maintenance; operator training and time to use tool.	Simple payback in less than 5 years

#### 3.1 Electricity Savings Estimation

To assess the energy savings objective, a simulation analysis was conducted. For each plant, measured cooling load data and observed weather conditions were used by the optimization algorithm to determine the optimal condenser water setpoint for a given day. Once this setpoint was determined, the operation of each plant for the given day was simulated using the developed models twice—once with the optimized setpoint and once with the conventional setpoint. The conventional setpoint represents the baseline operation (Section 2.5), while the optimized setpoint represents operation with the tool in use. This procedure was repeated every day for one year. The savings were taken as the difference between the total annual energy consumption simulated with baseline operation and that with optimized operation.

In addition to assessment of yearly energy savings with a simulation, energy savings were analyzed using measured data from the site over a brief 4-day period during which plant operators implemented setpoints suggested by the PlantInsight tool. In accordance with the International Performance Measurement and Verification Protocol (IPMVP) Option B (EVO 2012) the energy savings was estimated as defined in Equation 2. In this equation, kWh<sub>Baseline</sub> represents the measured energy consumption at a given cooling load with the baseline 22.2°C static setpoint. kWh<sub>Post\_Implementation</sub> represents the measured energy consumption at a given cooling load with the optimized tower setpoint from PlantInsight.

$$\text{kWh Savings} = \text{kWh}_{\text{Baseline}} - \text{kWh}_{\text{Post_Implementation}} \quad (2)$$

A linear regression baseline model was created with the data from the two months prior to optimized setpoint implementation. The total electricity use of the chiller and tower that were operational during this time period was regressed against the chiller’s cooling load. The resulting baseline model shows good fitness, with an R<sup>2</sup> of 0.8, normalized mean bias error of 0.04%, and CVRMSE of 6%. The fit between model and baseline data is shown in Figure 4. The equation for the baseline model is provided in Equation 3.:

$$\text{kWh}_{\text{Baseline}} = (0.53 * \text{cooling\_load (ton)} + 102.87) * \text{hours} \quad (3)$$

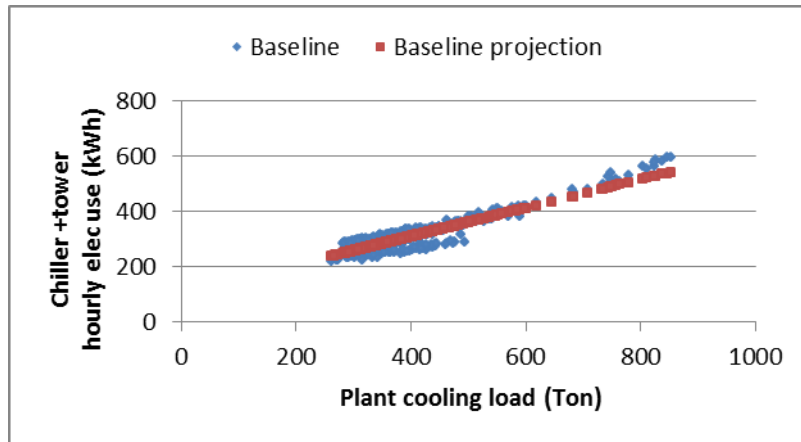

Figure 4. Baseline energy use, modeled (red) and metered (blue) electricity consumption

### 3.2 Evaluation of Model Calibration and System Economics

Calibration of the central plant models was evaluated to ensure that simulations were indeed representative of the plant’s actual performance, and therefore provide confidence in the robustness of the recommended optimized setpoints. Measured data from the central plant over a 16-month period prior to technology implementation were compared to model estimates. The data was filtered to isolate that associated with steady-state operations, and the GenOpt optimization engine was used to find model parameters that minimized the difference between the model outputs and the associated measured data. The goal of chiller calibration was to minimize the difference between the measured and simulated chiller Coefficient of Performance (COP) by tuning the coefficients of the equations that are used with the Chiller.ElectricEIR

model (Wetter 2014) to determine chiller power. The goal of tower fan calibration was to minimize the difference between the measured and the simulated fan power by tuning the coefficients of the fan curves used with the CoolingTower.YorkCalc model (Wetter 2014). The goal of tower leaving temperature calibration was to minimize the differences between the measured and the simulated tower leaving temperature by tuning the nominal wet bulb temperature and the nominal approach temperature used with the CoolingTower.YorkCalc model (Wetter 2014).

Assessment of system economics based on standard capital budgeting metrics provides a gauge for determining financial feasibility of the demonstration technology. A cost model was established reflecting estimated cost that would be required to implement the technology anew at a real site. The most significant cost drivers are hardware capital and installation costs, engineering costs to create and calibrate models, and operators' time to use the tool. All estimates are based on observations of team and partner experiences throughout the course of the demonstration. Simple payback was calculated based on the estimated cost and simulated annual energy cost reduction.

#### **4. Results**

Simulated and field-validated energy savings are presented, followed by assessment of model calibration with the PlantInsight tool.

##### **4.1 Central Plant Electricity Savings**

The annual simulation analysis was performed for the period of 9/7/2014 to 9/7/2015 and indicated that daily energy savings of greater than 10% can be obtained for approximately six months of the year, mainly during the winter season. However, on an annual basis, across all 12 months of the year, obtainable annual energy savings were 1.38% (434,785 kWh, \$30,435).

Figure 5 shows the monthly energy consumption of the two plants as a total (5a), monthly absolute savings (5b), and monthly savings as a percent of monthly baseline consumption (5c). While monthly relative savings during the winter can be higher than 25% (5c), the total power consumption is low during this time (5a), and therefore the contribution to annual savings is too low to meet the annual 10% target. The results showed that the main plant achieves greater than 10% energy savings 48% of the days of the year, while the secondary plant, which operates only during the summer, does not achieve greater than 10% energy savings for any portion of the year.

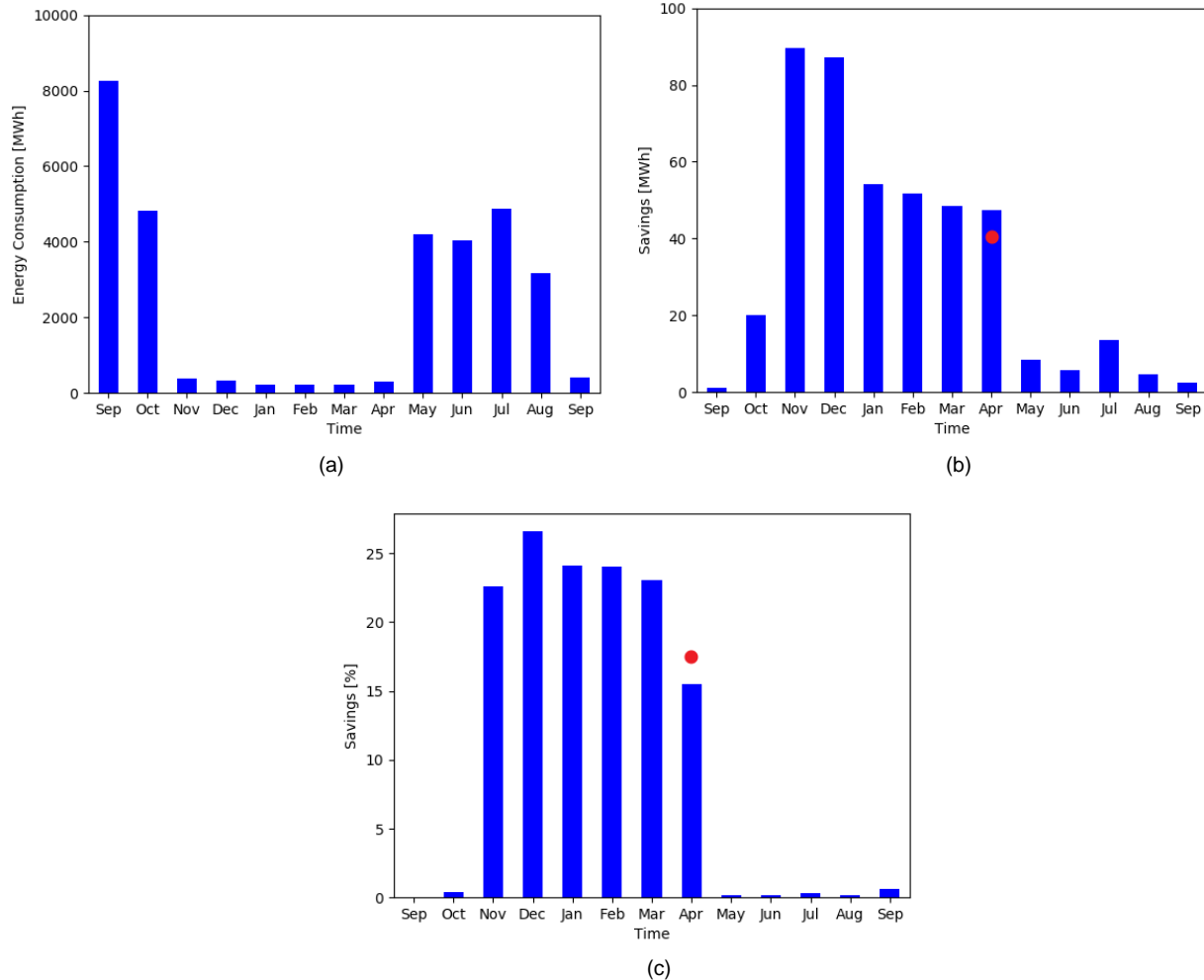
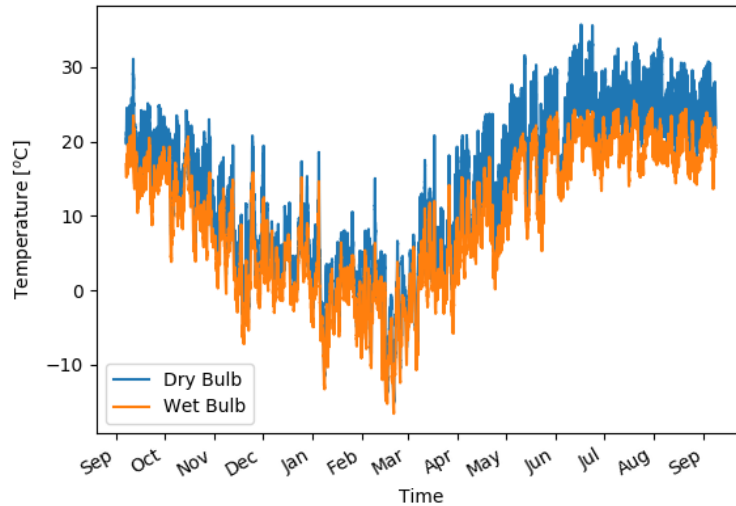

**Figure 5. Simulated monthly energy analysis for the simulation period 9/7/2014 to 9/7/2015: (a) absolute energy consumption, (b) absolute energy savings , and (c) relative energy savings. Demonstrated savings for a four day period in April extrapolated for the month is shown in red.**

Further analysis shows that savings potential is driven by outside wet bulb temperature in addition to the trade-off between cooling tower and chiller power consumption. Figure 6 shows the dry bulb and wet bulb temperatures for the period of the simulation. The optimization algorithm determines the most effective cooling tower condenser water temperature setpoint. The chillers' efficiency increases when the temperature of condenser water entering the chillers (same as the temperature of condenser water leaving the cooling towers) decreases. On the other hand, reducing that temperature will increase the energy consumption of cooling towers. Therefore, there is an optimum condenser water temperature setpoint for cooling towers that the total energy consumption of the chillers and the cooling towers is minimized. For the main plant, during the winter when savings potential is high, the optimal condenser water setpoint temperature is low due to low wet bulb temperatures, indicating that working the fans harder to achieve a lower condenser water temperature is worth the increase in chiller efficiency and lower chiller energy consumption. Figure 6 shows that these savings occur when the maximum daily wet bulb temperature is below approximately 15 °C. Meanwhile, in the summer, high wet



bulb temperatures limit the ability for the cooling towers to lower the condensing temperature and provide any energy savings. For the secondary plant, on days that provide a higher savings potential, the optimal condenser water setpoint temperature is high, indicating that working the fans less on those days is worth a slight loss in chiller efficiency. However, the savings in tower fan energy is relatively small compared to chiller power, and so the savings on the system is small.



**Figure 6. Ambient dry bulb and wet bulb temperatures in °C for the simulation period of 9/7/2014 to 9/7/2015.**

In addition to simulation, energy savings were evaluated using field testing data from the implementation of optimal setpoints over a four-day period in spring. During this time period, the site operational staff adjusted the cooling tower setpoint to the optimized setpoint suggested by the PlantInsight tool. After this time period, further implementation of the recommended optimal setpoints was precluded by chiller downtime and repairs, transitions to summer and term-time conditions, and time-sensitive resource-intensive projects that limited staff ability to conduct experimental operational changes. Figure 7 shows the savings results from projecting the baseline model (Section 3.1) to estimate the energy use that would have occurred during the test period had the optimized setpoints not been implemented. 17% savings were achieved over this four-day period, for a total of 5,436 kWh. This amount of savings extrapolated for the entire month (scaled by 30/4 for the number of four day periods in April) agrees with the expected monthly savings in April determined by the annual simulation, as shown in Figure 5b-c by the red markers.

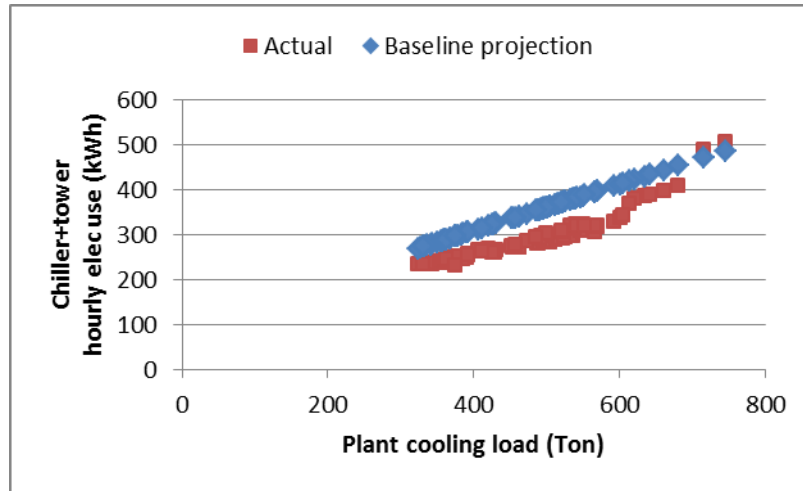

**Figure 7. Actual vs. baseline-predicted energy use over a four-day period in April during which 17% energy savings were quantified**

Although these results correspond to a short-term period of implementation, they serve to validate the simulation findings, which indicate comparable savings potential. Taken together, these analyses provide confidence in the assessment of demonstration performance objectives.

#### 4.2 Central Plant Model Calibration

The performance objective associated with plant model calibration stipulated that the difference between model-predicted and measured parameters be less than 10% for 90% of data points. This objective was satisfied for three of six chillers, and for each of the ten cooling towers for which there was sufficient data.

For the three chillers that could not be calibrated to the performance objective, it is suspected that the causes were either a limited volume of data representing full-capacity operation, erroneous data, or faulted operations underlying the data. In the case of the cooling towers, four cells could not be calibrated because the necessary calibration parameters were not available or were erroneous from the measured data history at the site. Since the model structure for each of the cooling towers were equivalent, the calibration parameters for towers that were well-calibrated were applied to those for which calibration data were not available.

Figures 8 and 9 contain selected examples of the calibration results for the chiller and cooling tower models. Figure 8 shows model-simulated versus measured COP for a case in which the performance objective was met, and for a case in which it was not met. Figure 9 shows model-simulated versus measured cooling tower fan power and cooling tower leaving temperature, for one of the ten towers for which the performance objective was met.

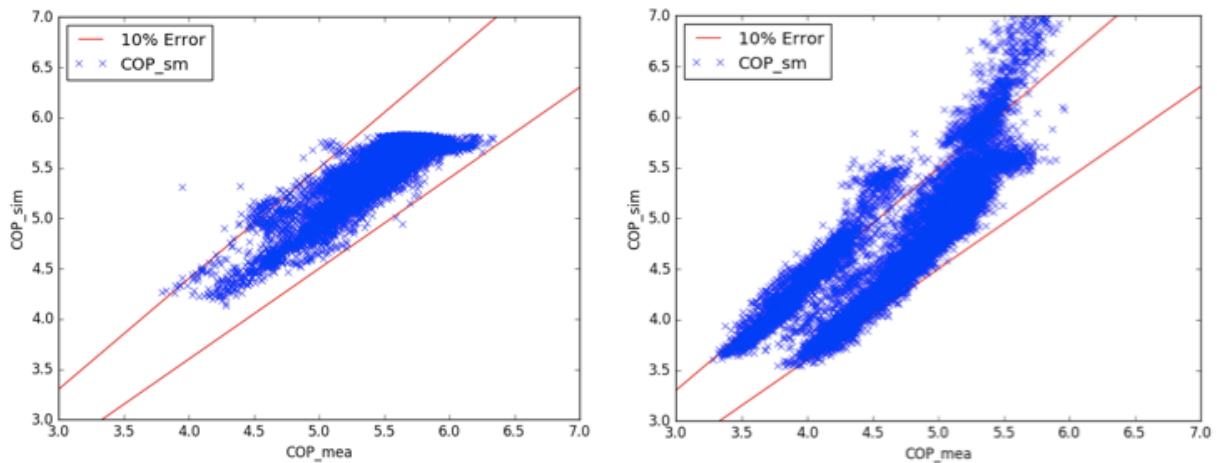

**Figure 8. Comparison of simulated and measured chiller coefficient of performance (COP) for one chiller for which the calibration performance objective was met (left), and for another chiller for which it was not met (right).**

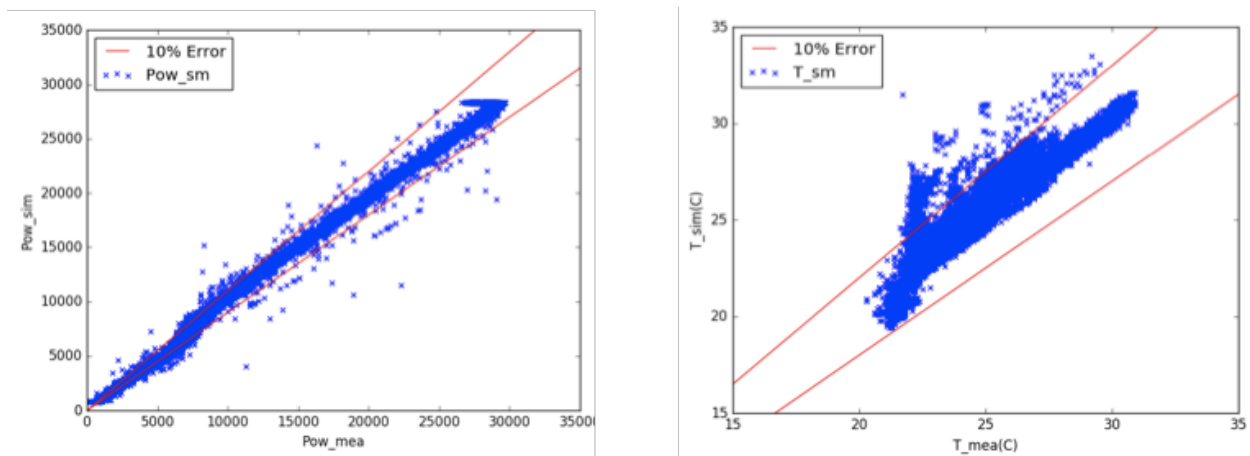

**Figure 9. Simulated and measured cooling tower fan power (left) and cooling tower leaving temperature (right) for Tower 3A. In both cases the calibration performance objective was met.**

Given that the majority of the models used in PlantInsight were able to be closely calibrated to the measured data from the site, the demonstration team was comfortable to incorporate the models into the PlantInsight tool. The assessment of the energy-savings performance objective confirmed that for key seasonal conditions (low wet bulb temperature), the model-derived optimized setpoints were indeed more efficient than the heuristic static setpoint typically used to operate the plant.

### 4.3 System Economics

To model and run the cost analysis, we assume implementation of the technology in a large facility approximately equivalent to that of the demonstration site. Hardware costs assume that, on average, six chiller flow meters may need to be added to provide the required data for the

tool, and that those meters would need periodic calibration. Similarly, models may require periodic updating by an engineer. Installation costs include the labor and material required to install the PlantInsight tool on a server and implement data export from the plant BAS to the PlantInsight database. The analysis showed that initial investment costs are \$34,600. The simple payback can be met in 1.4 years, well within the 5-year target that was established.

## **5. Discussion and Conclusions**

The results of this work showed that the model-based optimization technology was capable of delivering daily energy savings greater than 10% for approximately six months of the year, mainly during the winter season. However, for the year as a whole, energy savings of approximately 1.5% were obtainable. Since savings were driven by wet bulb temperature (lower), which occur in winter, when total plant consumption is lowest, larger annual savings are possible in drier climates.

Future development efforts will benefit from several insights gained throughout the course of this work. First, operators place strong value on access to tools that provide visibility into how controls impact energy use and cost. This is not as a rule available in today's commercial analytics technologies that span building automation systems, meter analytics tools, or equipment-specific fault detection and diagnostics tools. As such, HVAC optimization technologies represent advances in the state of today's available technology, and this is even more true of optimization tools that incorporate physics-based modeling approaches. Future development, implementations, and field tests will continue to contribute to the state of knowledge of their development and application.

Model-predictive optimization, combined with fault detection and diagnostics, is recognized as a critical aspect of realizing the dynamic low-energy buildings of tomorrow, and today's applications can deliver even more impact from expanding the set of parameters that are included in the optimization, as well as the number of end uses that are considered. Although these technologies represent advanced forward-looking applications, the external infrastructure to support their delivery at scale is mature; cloud hosting and computational scalability are well supported through modern IT solutions. In contrast, the most significant practical implementation barriers are the brittle building data acquisition and communication systems that present chronic challenges to analytics applications that need to interface with controls data.

Finally, we note that the creation and calibration of physics-based models that are intended to be used in the operational phase of the building life-cycle is highly dependent upon the specific algorithms with which they will be paired. The open, reference implementations that are delivered with PlantInsight are important contributions to industry's continued success in leveraging these promising approaches for next-generation building energy efficiency.

## **Acknowledgement**

This work was supported by the Assistant Secretary for Energy Efficiency and Renewable Energy, Building Technologies Office, of the U.S. Department of Energy under Contract No. DE-AC02-05CH11231. The authors would like to thank the Department of Defense Environmental

Security Technology Certification Program (ESTCP) for supporting this study, with special thanks to Timothy Tetreault (ESTCP), Christopher Crouse (NAVFAC HQ), Tim Rath (USNA), John Barton (USNA), Wangda Zuo (University of Miami), Michael Wetter, Oren Schetrit, Marco Bonvini, and Stephen Czarnecki (all of LBNL), and Daniel McQuillen (McQuillen Interactive).

## References

Blochwitz T, Otter M, Arnold M, Bausch C, Clauss C, Elmqvist H, and Wolf S. 2011. The functional mockup interface for tool independent exchange of simulation models. Modelica (March) 2011 Conference. 20–2.

Bonvini M, Sohn M, Granderson J, Wetter M, and Piette MA. 2014. Robust on-line fault detection and diagnosis for HVAC components based on nonlinear state estimation techniques. *Applied Energy* 124: 156–66.

Brambley MR and Katipamula S. 2009. Commercial building re-tuning: a low-cost approach to improved performance and energy efficiency. *ASHRAE Journal* 51(10): 12-23.

Coffey B, Haghghat F, Morofsky E, and Kutrowski E. 2017. A software framework for model predictive control with GenOpt. *Energy and Buildings* 42(7): 1084-92.

Corbin CD, Henze GP, and May-Ostendorp P. 2013. A model predictive control optimization environment for real-time commercial building application. *Journal of Building Performance Simulation* 6(3): 159-174.

Efficiency Valuation Organization (EVO). 2012. International performance measurement and verification protocol: Concepts and options for determining energy and water savings, Vol. I; January. EVO 10000-1.

Fernandez NE, Katipamula S, Wang W, Xie Y, Zhao M, and Corbin CD. 2017. Impacts of commercial building controls on energy savings and peak load reduction. Pacific Northwest National Lab Report 25985.. Richland, WA (United States).

Fernandes S, Granderson J, Singla R, and Touzani S. 2018. Corporate Delivery of a Global Smart Buildings Program. *Energy Engineering* 115(1): 7-25.

Friedrich S. 2013. Energy efficiency in buildings in EU countries. DICE Report.11:57–9.

Granderson, J and Lin G. 2016. Building energy information systems: Synthesis of costs, savings, and best-practice uses. *Energy Efficiency* 9(6): 1369-84.

Granderson J, Singla R, Mayhorn E, Ehrlich P, Vrabie D, and Frank S. 2017. Characterization and survey of automated fault detection and diagnostic tools. Lawrence Berkeley National Lab (LBNL) 2001075, Berkeley, CA (United States).

Greensfelder EM, Henze GP, and Felsmann C. 2011. An investigation of optimal control of passive building thermal storage with real-time pricing. *Journal of Building Performance Simulation* 4(2): 91-104.

Hail J, Hatley D. Underhill R. 2016. Optimization of variable speed chiller plants: Frank M. Jorhanson Jr. federal building and U.S. Courthouse, Montgomery, Alabama. U.S. General Services Administration Proving Ground program report.

Henderson P and Waltner M. 2013. Real-Time Energy Management: A Case Study of Three Large Commercial Buildings in Washington, D.C. Natural Resources Defense Council, CS:13-07-A.

Huang S and Zuo W. 2014. Optimization of the Water-Cooled Chiller System Operation. Proceedings of 2014 ASHRAE/IBPSA-USA Building Simulation Conference, Atlanta, Georgia, United States, Sep. 10–12. 300–7.

International Energy Agency (IEA). 2017. Key world energy statistics.

Julier SJ and Uhlmann JK. 1996. A general method for approximating nonlinear transformations of probability distributions. Robotics Research Group Technical Report. Department of Engineering Science, University of Oxford.

Kramer H, Lin G, Granderson J, Curtin C, and Crowe E. 2017. Synthesis of year 1 outcomes in the Smart Energy Analytics Campaign. Accessed on May 2, 2018 from <https://smart-energy-analytics.org/>

Lee SU, Painter FL, and Claridge DE. 2007. Whole-building commercial HVAC system simulation for use in energy consumption fault detection. *ASHRAE Transactions* 14(2): 52-61.

Lin G, Claridge DE. 2015. A temperature-based approach to detect abnormal building energy consumption. *Energy and Buildings* 93:110-8

Liu M, Claridge DE, and Turner WD. 2003. Continuous Commissioning<sup>SM</sup> of building energy systems. *ASME Journal of Solar Energy Engineering*, Transactions of the ASME, Special Issue on Emerging Trends in Building Design, Diagnosis and Operation 125(3): 275-81.

May-Ostendorp P, Henze GP, Corbin CD, Rajagopalan B, and Felsmann C. 2011. Model-predictive control of mixed-mode buildings with rule extraction. *Building and Environment* 46: 428-37.

Pang X, Wetter M, Bhattacharya P, and Haves P. 2012. A Framework for Simulation-based Real-time whole building performance assessment. *Building and Environment* 54: 100-8.

Polak E. 1997. Optimization algorithms and consistent approximations (Applied Math Science). Springer Verlage Publications. 124.

Smith D, Henritig J, Pittenger J, Bernard R, Kofmehl A, Levine A, Flaco G, Schmidt K, Granderson J, and Piette MA. 2011. Energy-smart buildings: Demonstrating how information technology can cut energy use and costs of real estate portfolios. Accenture.

Wetter M. 2001. GenOpt - A generic optimization program. In Proceedings of the 7th IBPSA Conference, Rio de Janeiro, Brazil, Aug. 13-15. 1: 601-8.

Wetter M, Zuo W, Nouidui TS, and Pang X. 2014. Modelica Buildings Library. *Journal of Building Performance Simulation* 7(4): 253–70.

U.S. Department of Energy (DOE). 2012. Building energy data book 2011.

U.S. General Services Administration (GSA). 2017. GPG Outbrief 03 Chiller plant control optimization System. Accessed on May 2, 2018 from <https://www.gsa.gov/governmentwide-initiatives/sustainability/gpg-program/outbrief-webinars>.