

# Lawrence Berkeley National Laboratory

## Recent Work

### Title

BEAM PROFILE SPAEK CHAMBER WITH MAGNETOSTRICTIVE READOUT

### Permalink

<https://escholarship.org/uc/item/7df4j8k4>

### Authors

Weisberg, Howard  
Perez-Mendez, Victor.

### Publication Date

1966-02-15

University of California  
Ernest O. Lawrence  
Radiation Laboratory

BEAM PROFILE SPARK CHAMBER  
WITH MAGNETOSTRICTIVE READOUT

TWO-WEEK LOAN COPY

*This is a Library Circulating Copy  
which may be borrowed for two weeks.  
For a personal retention copy, call  
Tech. Info. Division, Ext. 5545*

Berkeley, California

## DISCLAIMER

This document was prepared as an account of work sponsored by the United States Government. While this document is believed to contain correct information, neither the United States Government nor any agency thereof, nor the Regents of the University of California, nor any of their employees, makes any warranty, express or implied, or assumes any legal responsibility for the accuracy, completeness, or usefulness of any information, apparatus, product, or process disclosed, or represents that its use would not infringe privately owned rights. Reference herein to any specific commercial product, process, or service by its trade name, trademark, manufacturer, or otherwise, does not necessarily constitute or imply its endorsement, recommendation, or favoring by the United States Government or any agency thereof, or the Regents of the University of California. The views and opinions of authors expressed herein do not necessarily state or reflect those of the United States Government or any agency thereof or the Regents of the University of California.

Sub. to Nuclear Instruments & Methods

UCRL-16704

UNIVERSITY OF CALIFORNIA

Lawrence Radiation Laboratory  
Berkeley, California

AEC Contract No. W-7405-eng-48

BEAM PROFILE SPARK CHAMBER  
WITH MAGNETOSTRICTIVE READOUT

Howard Weisberg and Victor Perez-Mendez

February 15, 1966

BEAM PROFILE SPARK CHAMBER  
WITH MAGNETOSTRICTIVE READOUT\*

Howard Weisberg<sup>†</sup> and Victor Perez-Mendez

Lawrence Radiation Laboratory  
University of California  
Berkeley, California

February 15, 1966

ABSTRACT

We describe the construction and operation of a small spark chamber with magnetostrictive delay-line readout which is useful for measuring the spatial profile of particle beams. The beam profiles are accumulated directly in the memory of a multichannel analyzer. The advantages of this beam profile detector are good spatial resolution and accuracy, rapid accumulation of data, and convenience of use.

## I. INTRODUCTION

Various methods can be used to determine and monitor the profile of particle beams at accelerators. In intense primary beams, Polaroid film or television-viewed scintillators are useful. In less intense secondary beams, scintillation counter or spark chamber techniques can be used. One published method employs a small counter mounted on a motor-driven carriage.<sup>1</sup> Alternatively, one can use a scintillation counter hodoscope. Both these methods have the advantage that data can conveniently be accumulated, displayed, and read out in a conventional pulse-height analyzer. The disadvantage of the movable counter is that at low beam rates too much time is required to accumulate adequate statistics. The counter hodoscope makes maximum use of the incoming data, but presents cost and constructional problems when high resolution is required.

By using a spark chamber, one can combine high spatial resolution with efficient accumulation of information at low beam rates. The most straightforward readout method is photographic. One can get a density profile of the beam on film by making a multiple exposure of many sparks. In one method,<sup>2</sup> the spark chamber plates are semitransparent and the sparks are viewed along the beam line. However, with photographic readout one sacrifices the instantaneous data accumulation and quantitative display features of the counter methods using multichannel analyzers.

To combine the best features of both methods, we have constructed a beam-profile detector spark chamber using magnetostrictive delay-line readout.<sup>3,4</sup> We give in this article the constructional details of this system, and we also suggest some possible refinements of the method.

## II. CONSTRUCTIONAL DETAILS

A cutaway drawing of the spark chamber is shown in Fig. 1. There are two active gaps. The center (high voltage) plane is made of 4-mil aluminum. The two outer (ground) planes are made of 4-mil fiberglass epoxy plus 1-mil copper laminate. A pattern of 20-mil lines and 20-mil spaces is etched on the copper, and the lines on the two planes are orthogonal. The lines on each plane are connected to a ground strap at one edge of the plane. Slots in the central Lucite frames accommodate the pickup wands. These wands carry the nickel magnetostrictive ribbon, and have a pickup coil and shaper-amplifier at one end. The wands are identical to the ones described elsewhere.<sup>4</sup> Two edges of the central Lucite frames are polished to permit visual observation of the sparks. Three-mil outer Mylar windows contain the gas and prevent ground plane bowing due to unequal gas pressure.

The apparatus produces a readout signal in the following way. When a spark occurs, it conducts current to ground through one (or perhaps two) of the copper lines on the ground plane. This current, and the image current induced in the aluminum wand, induce a changing magnetic flux in the nickel ribbon at the point

where the copper line and nickel ribbon cross; since nickel is magnetostrictive, an acoustic pulse is induced in the ribbon and travels away in both directions at the velocity of sound in nickel. The pulse is absorbed in damping pads at both ends of the ribbon; however, at one end the ribbon passes through a pickup coil before reaching the damping pad. This coil is in an axial magnetic field of  $\approx 100$  gauss produced by a small permanent magnet. Thus by the inverse magnetostrictive effect, the acoustic pulse induces a voltage in the pickup coil. The time between the production of the spark and the reception of the magnetostrictive signal is proportional to the distance between the pickup coil and the copper line carrying the spark (the constant of proportionality is the inverse of the velocity of sound in nickel,  $5 \text{ mm}/\mu\text{sec}$ ).

Geometrical alignment and calibration are allowed for by a system of fiducial signals. Each fiducial signal is produced by connecting the free end of a printed line (in a region outside the active region of the chamber), through a resistor and a blocking condenser, to the high-voltage plane. Thus each time the chamber is pulsed, current flows through each fiducial line, and induces corresponding magnetostrictive signals. There is a total of four fiducials, two for each readout plane; in effect the system is self-calibrating. Cross hairs for optical alignment are mounted on the outer spark chamber frame, and the alignment of cross hairs and fiducial lines is maintained to within 5 mils by optical alignment techniques during assembly.

The various planes are assembled with epoxy cement,



except that the joints between the ground planes and the central frames use O rings and are demountable. The high-voltage and ground planes are stretched tight, and care is taken to ensure that they remain taut over a wide ambient temperature range, despite the effects of differential expansion. The frames to which the circuit boards are glued are made of NEMA-G, a material having a coefficient of expansion similar to that of the circuit planes. The circuit planes are glued under tension at a temperature of 40° F.

The active area of the chamber is defined by the 6.5-in. square cutout in the 3-mil Mylar sheet that is glued over the ground plane. This opening is made smaller than that in the central frame, in order to prevent edge sparking. The Mylar also ensures that the O-ring seal is gas tight.

Figure 2 is a photograph of the chamber in its mounting frame. Its spark-gap pulser<sup>5,6</sup> is mounted on the same frame. All the gas and electrical connections to and from the chamber are bundled together in a single, 100-ft-long umbilical cord leading to the relay rack containing the electronics and gas-handling system. The rack also has a reel for the cord, and a holder for the chamber when not in use. The only external requirements are ac power, a neon source, a compressed air source for the high-voltage pulser if the chamber is to be used near a hydrogen target, and a connection to the input of a multichannel pulse-height analyzer.

A block diagram of the system is shown in Fig. 3. The chamber may be triggered either from its own scintillation counters, whose connections are included in the umbilical cord, or from an external beam-defining telescope. In case one wants to avoid the delays introduced by the long cables and the relatively slow electronics, it is possible to run a triggering line from an external fast source directly to the pulser on the spark chamber frame.

For some beam-finding applications, a simpler triggering scheme may be useful: the chamber can be triggered completely asynchronously (or in synchronism with the accelerator bursts at a pulsed accelerator). This method can be used provided the instantaneous beam rate is high enough ( $10^5$  to  $10^6$  particles per second) that a particle passage is probable during the sensitive time of the chamber.

The chamber is operated with a continuously flowing filling of 90% Ne, .10% He. With a flow of 1 ft<sup>3</sup> per hour through 100 ft of vinyl tubing, the chamber can be brought from air to normal operating conditions in a few hours. Stability is maintained by a flow of a few tenths ft<sup>3</sup> per hour. The addition of alcohol for quenching is not necessary.

### III. READOUT

A typical signal from one of the pickup wands is seen in Fig. 4, which shows the spark noise, first fiducial, spark signal, and second fiducial. The block diagram of the readout system is shown in Fig. 5. This readout system is designed to use standard

laboratory electronics modules. It reads out one piece of information per spark. The timing information is converted to an amplitude signal by the time-to-height converter, for analysis by the multichannel analyzer. The signal which triggers the chamber also provides the "start" signal. The magnetostrictive readout signal (Fig. 4) provides the "stop" signal. However, the initial part of the readout signal is gated out by the gate, G. Normally the gate width is set so that both the spark noise and the first fiducial are gated out. The "stop" signal thus comes from the spark signal or, if no spark is present, from the second fiducial. For the first few hundred sparks of a profile, however, one manually reduces the gate width slightly so the "stop" signal comes from the first fiducial rather than the spark or the second fiducial. Thus the information stored in the analyzer consists of a sharp peak corresponding to the first fiducial, the beam profile, and another peak for the second fiducial; in this way the system is self-calibrating.

A beam profile measured with the system is shown in Fig. 6. This profile was taken in the 315-MeV/c pion beam of an experiment in progress to measure the  $\pi^+$  and  $\pi^-$  lifetimes.<sup>7</sup> The beam was defined by a scintillation counter coincidence-anticoincidence telescope before the spark chamber, and a focusing liquid hydrogen Cerenkov counter after it.

As determined in other work,<sup>4</sup> the linearity is better than  $1 \times 10^{-3}$  and the correlation of the spark readout position with the trajectory of the particle is  $< 0.5$  mm.

#### IV. POSSIBLE IMPROVEMENTS

A more flexible readout system could have some advantages. In particular, if both spark signals and all four fiducial signals could be read out simultaneously, the time required to accumulate a complete set of profiles could be cut to less than half. Accomplishing this would require some sort of temporary storage, analog or digital.

In some critical beam-alignment problems it may be desirable to determine not only the spatial profile, but also the angular profile of the beam. This can be done by a straightforward extension of the present system. A second chamber, located a suitable distance downstream in the beam, is required. The readout system needs to record the difference in coordinate between sparks in the two chambers. This could be done with the simple system shown in Fig. 7; alternatively, a more flexible (and hence more complicated) system could be used.

#### ACKNOWLEDGMENTS

We thank Ralph Peters and Albert Watanabe for help with the mechanical design of the chamber, Fred Kirsten and James Pfab for help with the electronics, and the persons named in Ref. 7 for use of their beam.

FOOTNOTES AND REFERENCES

\*Work done under auspices of the U. S. Atomic Energy Commission.

†N. S. F. Postdoctoral Fellow

1. Julius Solomon and Sytko Andraea, Rev. Sci. Instr. 34, 1126 (1963).
2. G. Culligan, D. Harting, and N. H. Lipman, A Spark Chamber Hodoscope, CERN Report 61-25 (unpublished).
3. Victor Perez-Mendez and James Pfab, Nucl. Instr. Methods 33, 141-146 (1965).
4. Frederick A. Kirsten, Victor Perez-Mendez, and James M. Pfab, Development of Magnetostrictive Chamber Readouts, Lawrence Radiation Laboratory report UCID-2629, August 19, 1965.
5. Louis Lavoie, Sherwood Parker, Charles Rey, and Daniel M. Schwartz, Rev. Sci. Instr. 35, 1567-1561 (1964).
6. Sherwood I. Parker and Charles A. Rey, A Compact Low-Inductance Spark Chamber Pulser (UCRL-16654, Jan. 1966), submitted to Nucl. Instr. Methods.
7. David S. Ayres, Richard D. Eandi, Arthur S. Greenberg, Robert W. Kenney, Richard J. Kurz, Burns Macdonald, David O. Caldwell, and Brenton F. Stearns (Lawrence Radiation Laboratory), private communication, 1965.

FIGURE CAPTIONS

- Fig. 1. Cutaway drawing of spark chamber.
- Fig. 2. Photograph of chamber, mounting frame, and pulser.
- Fig. 3. Block diagram of spark chamber system.
- Fig. 4. Typical signals from readout wand. Scale is 5  $\mu$ sec/cm horizontal, 1 V/cm vertical.
- Fig. 5. Block diagram of readout system.
- Fig. 6. Measured beam profile. Calibration factor 9.9 channels per inch. Clearing field 20 V. The peak in channels 8 and 87 are the fiducial counts.
- Fig. 7. Readout system for angular divergence of beam.

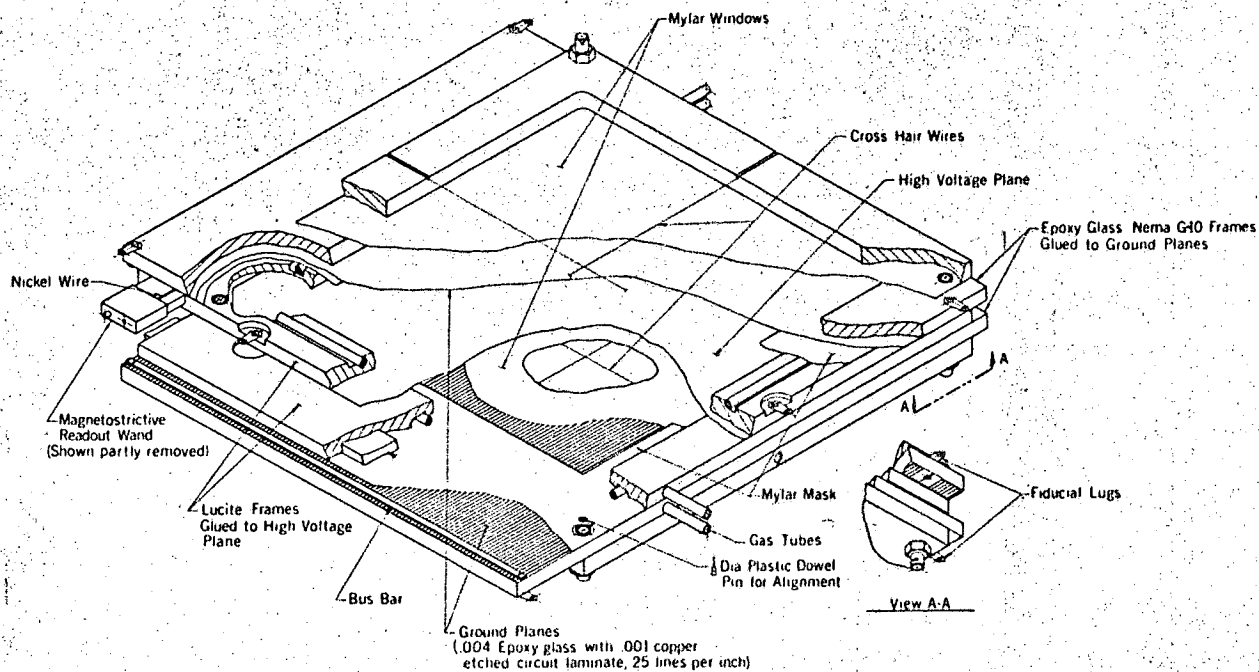
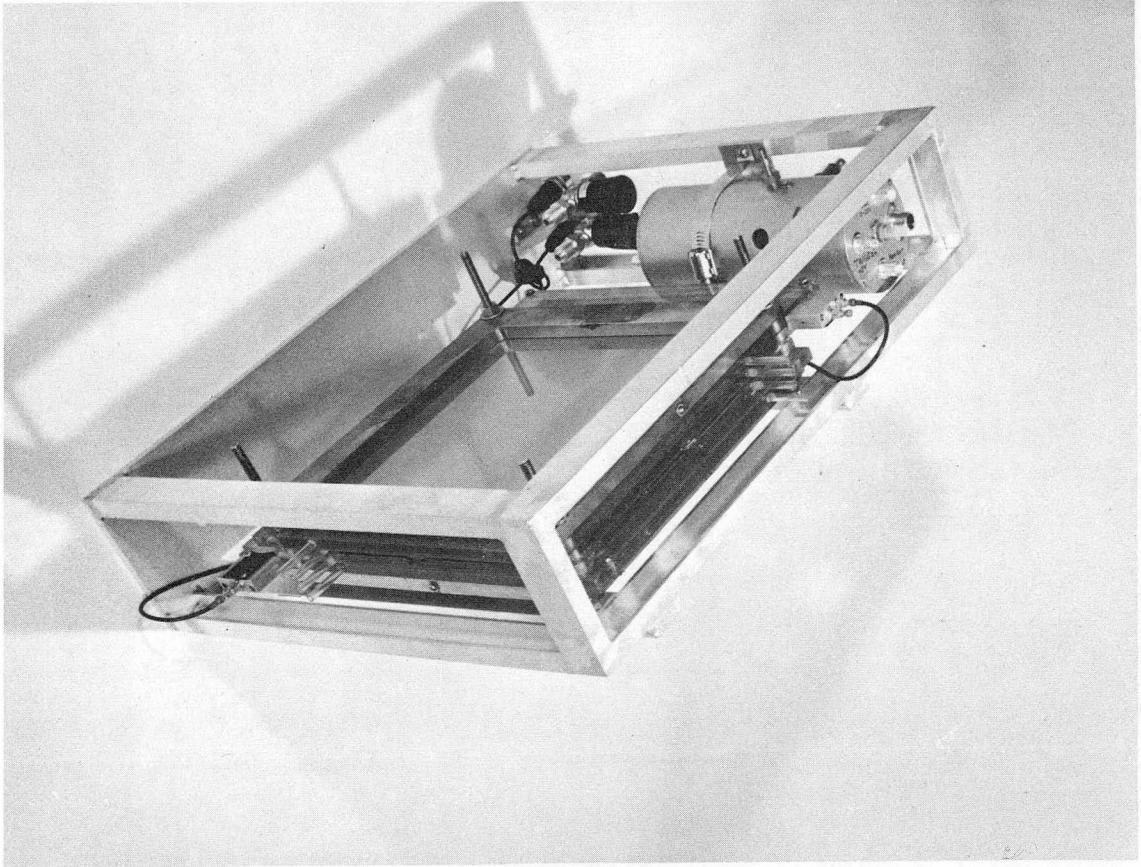

Fig. 1



ZN-5402

Fig. 2



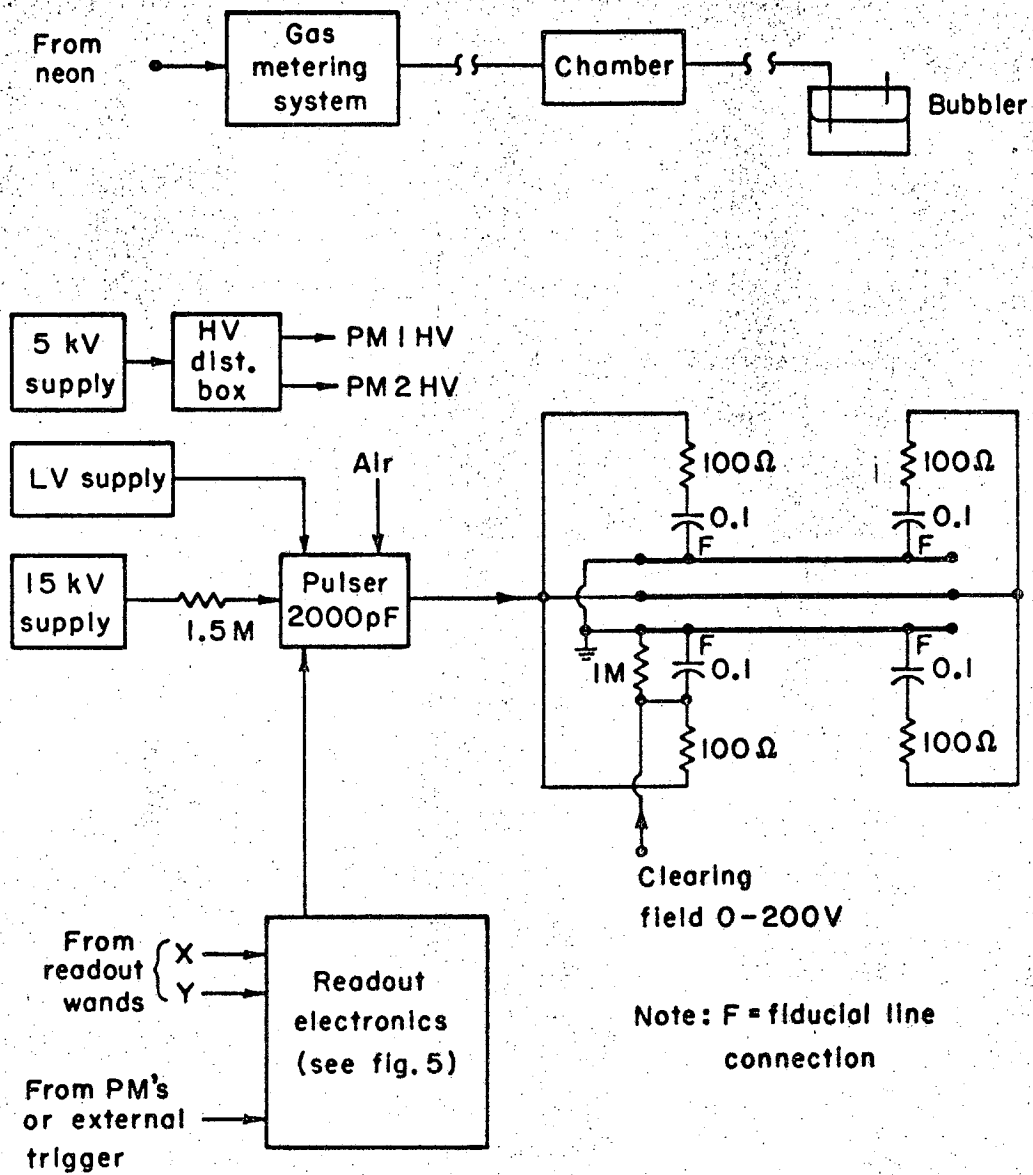
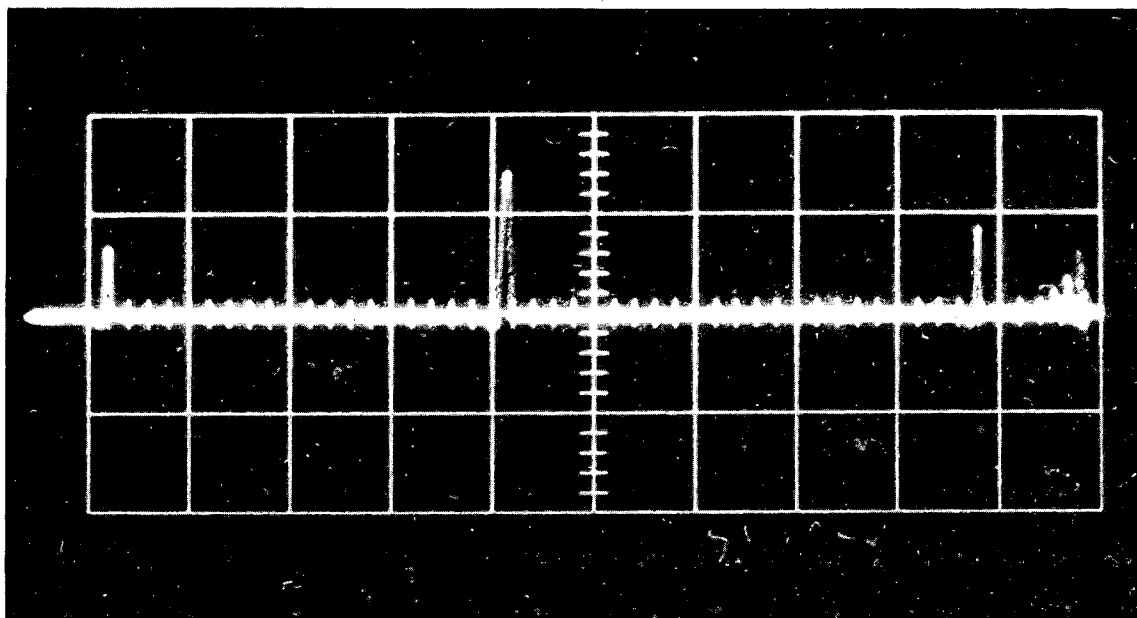

Fig. 3

MUB-9571



ZN-5403

Fig. 4

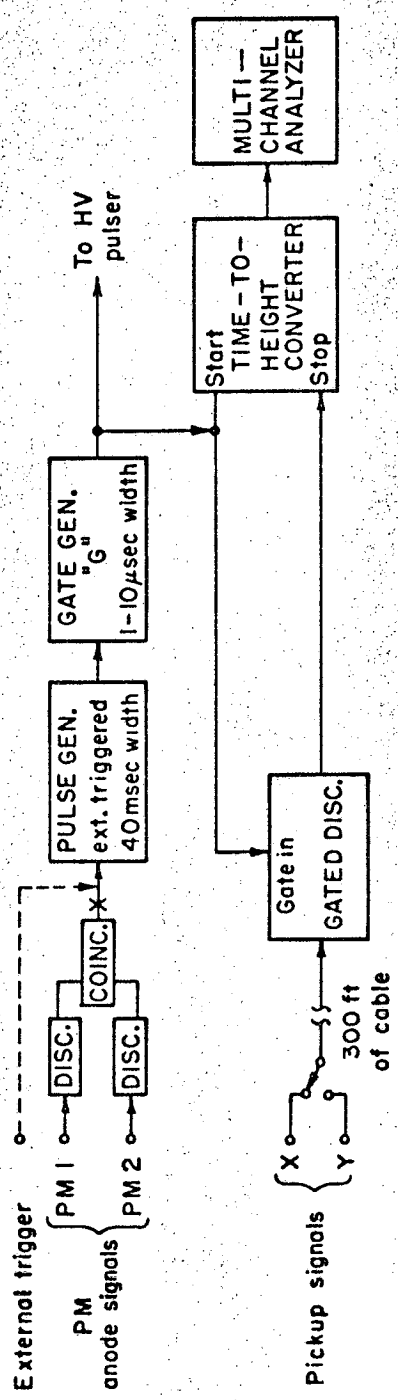

MUB-9572

Fig. 5

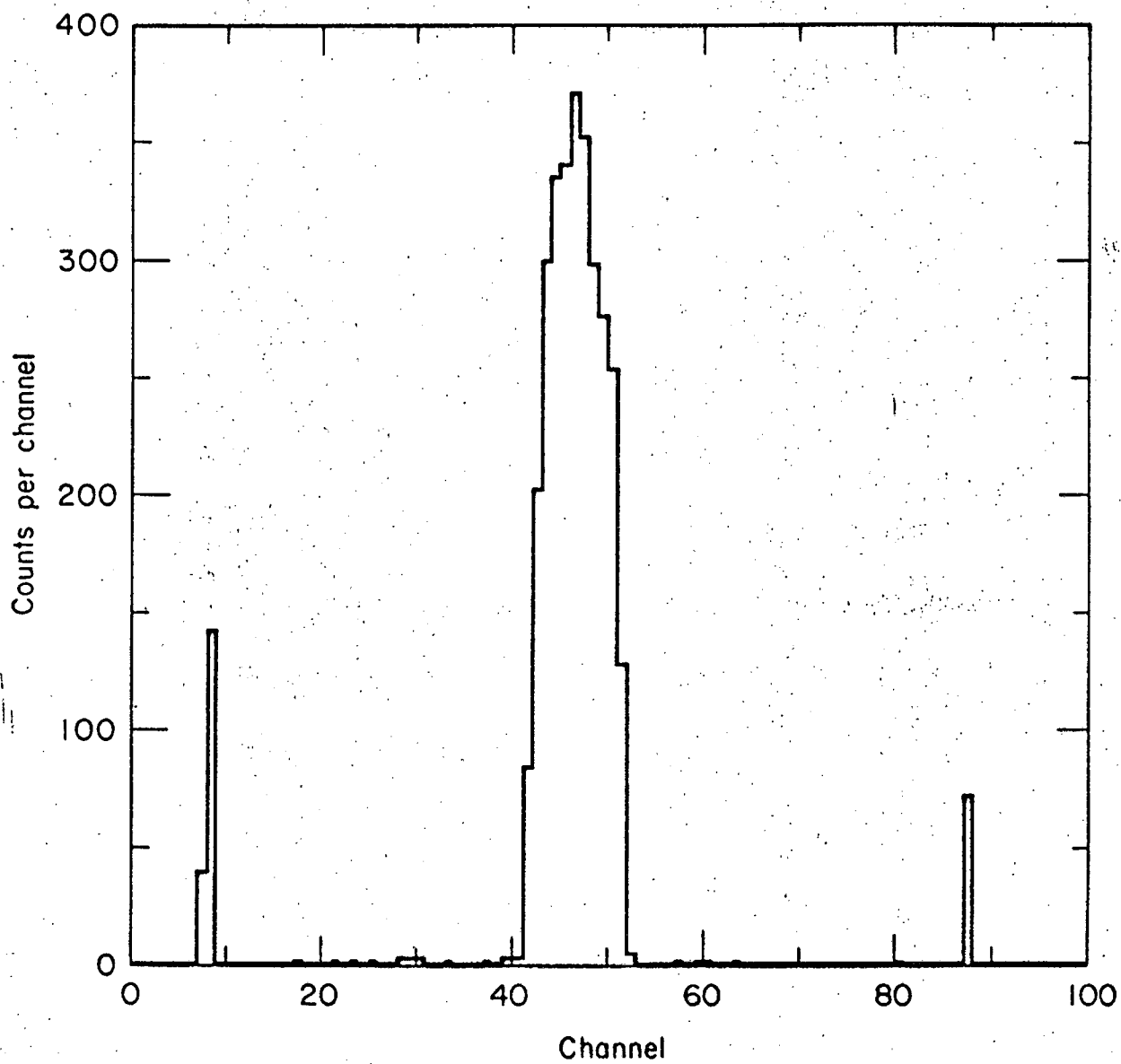

MUB-9573

Fig. 6

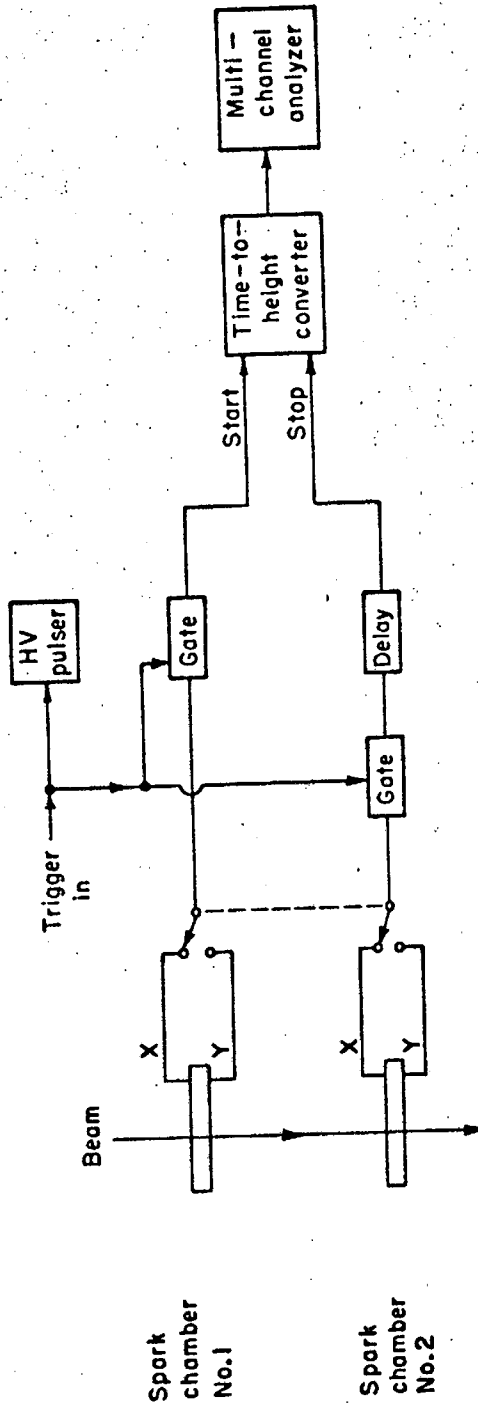

MUB-9574

Fig. 7

This report was prepared as an account of Government sponsored work. Neither the United States, nor the Commission, nor any person acting on behalf of the Commission:

- A. Makes any warranty or representation, expressed or implied, with respect to the accuracy, completeness, or usefulness of the information contained in this report, or that the use of any information, apparatus, method, or process disclosed in this report may not infringe privately owned rights; or
- B. Assumes any liabilities with respect to the use of, or for damages resulting from the use of any information, apparatus, method, or process disclosed in this report.

As used in the above, "person acting on behalf of the Commission" includes any employee or contractor of the Commission, or employee of such contractor, to the extent that such employee or contractor of the Commission, or employee of such contractor prepares, disseminates, or provides access to, any information pursuant to his employment or contract with the Commission, or his employment with such contractor.

