

Lawrence Berkeley National Laboratory

Recent Work

Title

MANUAL ON INDOOR AIR QUALITY

Permalink

<https://escholarship.org/uc/item/74x6f59r>

Authors

Diamond, R.C.

Grimsrud, D.T.

Publication Date

1983-12-01



Lawrence Berkeley Laboratory

UNIVERSITY OF CALIFORNIA

APPLIED SCIENCE
DIVISION

RECEIVED
LAWRENCE
BERKELEY LABORATORY

MAR 14 1984

LIBRARY AND
DOCUMENTS SECTION

MANUAL ON INDOOR AIR QUALITY

R.C. Diamond and D.T. Grimsrud

December 1983

TWO-WEEK LOAN COPY

This is a Library Circulating Copy
which may be borrowed for two weeks.
For a personal retention copy, call
Tech. Info. Division, Ext. 6782.

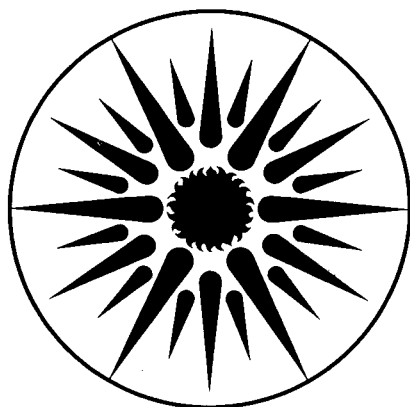

APPLIED SCIENCE
DIVISION

LBL-17049
c.2

DISCLAIMER

This document was prepared as an account of work sponsored by the United States Government. While this document is believed to contain correct information, neither the United States Government nor any agency thereof, nor the Regents of the University of California, nor any of their employees, makes any warranty, express or implied, or assumes any legal responsibility for the accuracy, completeness, or usefulness of any information, apparatus, product, or process disclosed, or represents that its use would not infringe privately owned rights. Reference herein to any specific commercial product, process, or service by its trade name, trademark, manufacturer, or otherwise, does not necessarily constitute or imply its endorsement, recommendation, or favoring by the United States Government or any agency thereof, or the Regents of the University of California. The views and opinions of authors expressed herein do not necessarily state or reflect those of the United States Government or any agency thereof or the Regents of the University of California.

MANUAL ON INDOOR AIR QUALITY

Richard C. Diamond and David T. Grimsrud

Applied Science Division
Lawrence Berkeley Laboratory
University of California
Berkeley, California 94720

Submitted to

Electric Power Research Institute
3412 Hillview Avenue
Palo Alto, California 94304

December 1983

This work was supported by the Assistant Secretary for Conservation and Renewable Energy, Office of Building Energy Research and Development, Buildings Systems Division of the U.S. Department of Energy under Contract No. DE-AC03-76SF00098, and by the Electric Power Research Institute under Subcontract No. RP2034-3.

ACKNOWLEDGMENTS

The authors wish to thank Dr. Arvo Lannus, Project Manager at the Electric Power Research Institute, for his advice and guidance throughout all phases of the writing and production of this manual. In addition, the authors wish to thank the following persons who took time to provide information or to review part or all of the manual:

Peter Cleary, William Fisk, John Girman, Francis Offermann, William Nazaroff, Beth Schwehr, Robin Spencer, and Gregory Traynor.

Project Staff

David Grimsrud, Project Manager/Co-Author (Staff Scientist, Co-Group Leader, Building Ventilation and Indoor Air Quality Group, Lawrence Berkeley Laboratory)

Richard Diamond, Co-Author (Staff Scientist, Energy Performance of Buildings Group, Lawrence Berkeley Laboratory)

J. Laurel Cook, Editor

Moya Melody, Graphics and Layout (Publications Coordinator, Energy Efficient Buildings Program, Lawrence Berkeley Laboratory)

NOTICE

This report was prepared by the organization named below as an account of work sponsored by the Electric Power Research Institute, Inc. (EPRI). Neither EPRI, members of EPRI, the organization named below, nor any person acting on behalf of any of them: (a) makes any warranty, express or implied, with respect to the use of any information, apparatus, method, process disclosed in this report or that such use may not infringe privately owned rights; or (b) assumes any liabilities with respect to the use of, or for damages resulting from the use of, any information, apparatus, method, or process disclosed in this report.

Prepared by Applied Science Division, Lawrence Berkeley Laboratory, University of California, Berkeley, California, 94720.

ABSTRACT

This reference manual was prepared to assist electric utilities in helping homeowners, builders, and new home buyers to understand a broad range of issues related to indoor air quality. The manual is directed to technically knowledgeable persons employed by utility companies--the customer service or marketing representative, applications engineer, or technician--who may not have specific expertise in indoor air quality issues.

In addition to providing monitoring and control techniques, the manual summarizes the link between pollutant concentrations, air exchange, and energy conservation and describes the characteristics and health effects of selected pollutants. Where technical information is too lengthy or complex for inclusion in this volume, reference sources are given. Figures and tables are presented to complement text material.

Information for this manual was gathered from technical studies, manufacturers' information, and other materials from professional societies, institutes, and associations. The aim has been to provide objective technical and descriptive information that can be used by utility personnel to make informed decisions about indoor air quality issues.

CONTENTS

Section

1 INTRODUCTION

The indoor air quality issue; relationship between air exchange rate and indoor pollutant levels; purpose, scope, and organization of manual; glossary of important terms.

2 AIR EXCHANGE: INFILTRATION AND VENTILATION

Definitions of infiltration and ventilation; how and where infiltration occurs; typical air exchange rates; energy costs of infiltration; infiltration reduction techniques; ventilation standards.

3 FACTORS AFFECTING INDOOR AIR QUALITY

Characterization of air and air pollutants, pollutant variation and distribution; factors affecting air quality.

4 INDOOR AIR POLLUTANTS

Key indoor pollutants identified and characterized; sources; concentrations; field studies.

5 HEALTH EFFECTS AND STANDARDS

Health effects for select pollutants; current standards; epidemiologic studies.

6 MONITORING AND MODELING INDOOR AIR QUALITY

Techniques and equipment; fixed location samplers; personal monitors; modeling

7 MEASURING AND MODELING INFILTRATION

Techniques for measuring air infiltration: tracer gas and fan pressurization; effective leakage area; models.

8 POLLUTANT CONTROL

Control techniques; source control; ventilation; air cleaning; future technologies.

APPENDIX A Sources of U.S. Residential Air-to-Air Heat Exchangers

APPENDIX B Manufacturers of Air Cleaning Devices

INDEX

ILLUSTRATIONS

<u>Figure</u>	<u>Page</u>
2-1 Infiltration sites	2-3
2-2 Variations in air exchange in a Chicago house	2-4
2-3 Infiltration rates in U.S. houses	2-5
2-4 Heating season infiltration load for U.S.	2-6
3-1 Factors affecting indoor pollutant concentration	3-3
3-2 Sources of pollutants	3-6
4-1 Radon decay chain	4-2
4-2 Primary pathways for radon entry into buildings	4-3
4-3 Frequency distribution for radon source magnitude for 98 houses	4-4
4-4 Residential formaldehyde concentrations	4-6
6-1 Formaldehyde sampler pump	6-5
6-2 Mobile indoor air quality laboratory	6-6
6-3 Passive samplers	6-8
7-1 Tracer-gas analyzer	7-2
7-2 Tracer gas decay	7-3
7-3 Blower-door used for fan pressurization test	7-5
8-1 Effect of ventilation on radon levels	8-5
8-2 Mechanical ventilation system with air-to-air heat exchanger	8-6
8-3 Typical air cleaners	8-8

TABLES

<u>Table</u>	<u>Page</u>
2-1 Component air leakage values	2-3
2-2 Ventilation standards for dwellings	2-9
3-1 Sources and types of indoor air pollutants	3-5
5-1 National primary ambient air quality standards as set by the U.S. Environmental Protection Agency	5-3
5-2 Occupational safety and health standards as set by the U.S. Occupational Safety and Health Administration	5-4
5-3 Radon standards	5-6
5-4 Reported health effects of formaldehyde at various concentrations	5-9
5-5 Formaldehyde standards	5-10
6-1 Nitrogen dioxide: passive integrating monitors	6-12
6-2 Formaldehyde: passive integrating monitors	6-13
6-3 Respirable suspended particles: active integrating monitors	6-14
6-4 Radon: passive integrating monitors	6-15
6-5 Carbon monoxide: active integrating monitors	6-16

Section 1
INTRODUCTION

IN THIS SECTION: The indoor air quality issue; relationship between air exchange rate and indoor pollutant levels; purpose, scope, and organization of manual; glossary of important terms.

Although the passage of the Clean Air Act in 1963 effectively focused national attention on cleaning up the outdoor air, relatively little effort has been directed towards investigating the quality of air indoors. In the United States today, people spend only 10-20% of their time outdoors; the rest is spent at home, at work, or traveling in between. Yet existing air quality regulations are based solely on outdoor conditions, specifically on large-scale, highly visible, outdoor, air-pollution sources, such as industrial effluents and vehicle exhaust. Buildings were assumed to shelter occupants from outdoor pollutants, and little thought was given to pollutants generated or trapped indoors. Recent studies have shown that concentrations of certain pollutants inside houses exceed standards set for outdoor concentrations. Because health effects are often correlated with exposure over time, it is now clear that air quality indoors requires far more attention than it has yet received. As an emerging health problem, contamination of indoor air has been linked with a wide variety of building materials and consumer products, as well as strategies that reduce the amount of infiltrating air as a means of promoting energy conservation.

Two main factors govern the concentration of any given pollutant indoors: the source strength of the pollutant and its removal rate. Residential buildings have various sources of indoor air pollution. People (and their pets) generate carbon dioxide, moisture, odors, and microbes simply through normal biological processes. Other more important potential sources of indoor air pollution are combustion appliances (gas stoves, forced-air furnaces, unvented space heaters, wood stoves); building materials (used in construction, furnishings, and insulation); tobacco, and the soil under and around the structure.

Air flow into and out of a building is usually the principal means of removing these indoor contaminants. Reducing air flow rates, however, is one of the most cost-effective strategies for improving the energy efficiency of buildings. Perhaps

one-third to one-half of the heat loss (and cooling loss) in residential buildings is due to this air exchange between indoors and out.* Although effective in conserving energy, lowering the air exchange rate in a structure generally slows the transport of indoor-generated air pollutants to the outside, trapping the pollutants inside the structure. Many indoor air quality problems surfaced when air exchange rates were drastically reduced (in the interests of energy efficiency) and the pollution effects became obvious to building inhabitants.

In the past few years, even though the number of studies designed to measure and evaluate the concentrations of indoor air pollutants has greatly increased, many important questions remain unanswered. For example, we have few data on the long-term health effects of single pollutants, and even fewer on how the body reacts to simultaneous exposure to several pollutants--a common experience of building occupants. Furthermore, even though numerous sources of pollutants have been identified, we do not fully understand their variability in location and strength.

PURPOSE OF THIS MANUAL

The purpose of this manual is to provide a reference guide on indoor air quality and its relationship to air infiltration and energy use in residential buildings. It provides a review of the knowledge gained from extensive laboratory and field studies in these areas, and it reproduces selected tables and figures designed to help utility specialists understand the critical issues in indoor air quality so that they, in turn, can provide useful and detailed information to inquiring customers. To that end, substantial technical information is included in summarized form, although, in general, the manual is written and illustrated for persons who may not have a technical background in this area. A glossary of terms used in air quality and related research areas is presented at the end of this section.

SCOPE OF THE MANUAL

This manual was prepared by scientists in the Energy Performance of Buildings and the Building Ventilation and Indoor Air Quality groups at the Lawrence Berkeley Laboratory. Their charge was to prepare an authoritative manual describing current issues and knowledge in the area of indoor air quality in residential buildings, identifying key pollutants and presenting the key issues that pertain to indoor air quality.

* Office of Technology Assessment, Residential Energy Conservation, Washington, D.C.: U.S. Government Printing Office, July 1979.

ORGANIZATION OF THE MANUAL

The manual is divided into eight sections as follows: Section 1, Introduction, sets up the context for the indoor air quality issues to be covered and describes the purpose, scope, and organization of the manual. Section 2, Air Exchange: Infiltration and Ventilation, describes the connection between reducing air exchange rates for energy conservation and reducing ventilation for controlling pollutant levels. Current ventilation requirements and standards are also presented. Section 3, Indoor Air Quality, explains the general characteristics of air pollutants, their distribution, and their variability. Also examined for their effect on indoor air quality are: external environment, structural and interior design, materials, and occupant activities. Section 4, Characterization of Indoor Air Pollutants, looks at specific pollutants in greater detail. Section 5, Health Effects and Air Quality Standards, reviews current guidelines for pollutants and summarizes information on health effects. Section 6, Monitoring and Modeling Indoor Air Quality, and Section 7, Measuring and Modeling Infiltration, discuss the applicability, as well as the advantages and disadvantages, of available techniques. Section 8, Pollutant Control, summarizes specific control techniques and discusses their uses and limitations.

Each section, introduced by a capsule summary of major topics contained in the section, presents the "basic issues" necessary for understanding the more technical information that follows. Whenever appropriate, information is incorporated in charts and tables for easy reference. For readers interested in more detailed information, references are given at the end of each section.

Information contained in this manual is based on technical papers and reports from private and government-funded research, conference proceedings, federal interagency workshops, and recently published volumes. The following references provide additional information on indoor air quality issues:

Indoor Pollutants (1981). National Research Council of the National Academy of Sciences. Published by the National Academy Press, Washington, D.C., 20418.

Indoor Air Pollution (1982). Proceedings of the International Symposium on Indoor Air Pollution, Health, and Energy Conservation. Published in a special issue of Environment International, Pergamon Press, New York.

Workshop on Indoor Air Quality Research Needs (1981). Report of the Interagency Research Group on Indoor Air Quality. U.S. Department of Energy, Office of Conservation and Renewable Energy, Washington, D.C., 20585.

Ventilation for Acceptable Air Quality, ASHRAE Standard 62-1981 (1981). Published by the American Society of Heating, Refrigerating and Air-Conditioning Engineers, 1791 Tullie Circle NE, Atlanta, Georgia, 30329.

Indoor Air Quality Handbook (1982). Prepared for the U.S. Department of Energy, by Sandia National Laboratories. Available from National Technical Information Service, 5285 Port Royal Road, Springfield, Virginia, 22161.

GLOSSARY

ACCEPTABLE AIR QUALITY. Air in which there are no known contaminants at harmful concentrations and with which a substantial majority (usually 80%) of the people exposed do not express dissatisfaction. [ASHRAE 62-81]

AEROSOL. A gaseous suspension of fine solid or liquid particles.

AIR CLEANER. A device used to remove airborne impurities such as dust, gases, vapors, fumes, and smoke.

AIR EXCHANGE RATE. The number of times the volume of air in a space is exchanged with outdoor air in a given period of time (usually expressed as "air changes per hour" or "ach").

ALDEHYDES. Any of a class of highly reactive organic compounds containing the chemical group -CHO, used in the manufacture of resins and dyes, and having strong odors.

ALPHA PARTICLE. A positively charged atomic particle that is ejected in certain radioactive transformations.

AMBIENT AIR. That portion of the atmosphere, external to buildings, to which the general public has access. [EPA 1976]

BECQUEREL. The SI unit for the rate of radioactive decay in a sample of material. One becquerel (Bq) equals one disintegration per second (see also, curie).

BUILDING ENVELOPE. The exterior surfaces of a building--specifically, walls, roof, and floor (if over unheated basement, slab, or crawlspace).

CARBON MONOXIDE. A colorless, odorless, toxic gas, formed as a by-product of incomplete combustion.

COMBUSTION APPLIANCE. A fuel-burning (oil, gas, coal, or wood) device such as a range, furnace, or water heater.

CONCENTRATION. The quantity of one constituent dispersed in a defined amount of another; for example, lb per ft³, kg/kg, or parts per million (ppm).

CONTAMINANT. Any airborne constituent that reduces the quality of the air.

CRITERIA POLLUTANT. EPA has set standards for the following pollutants in outdoor air: nitrogen dioxide, sulfur dioxide, ozone, lead, carbon monoxide, and total suspended particles.

CURIE. A unit used to describe the rate of radioactive decay in a sample of material. One curie (Ci) equals 37 billion disintegrations per second.

DAUGHTERS (progeny). The new radionuclides formed by the radioactive decay of a parent radionuclide.

DUST. An air suspension of particles of any solid material, usually less than 100 micrometers in size.

EMISSION RATE. Amount of a contaminant released into the air by a source in a specified amount of time.

EPIDEMIOLOGY. A science that deals with the incidence, distribution, and control of diseases in a population.

FORMALDEHYDE (HCHO). A colorless, gaseous compound, used in the manufacture of resins and dyes, and as a preservative and disinfectant. Present in many synthetic materials.

INFILTRATION. Air leakage through cracks and gaps, and through ceilings, floors, and walls of a building.

NATURAL VENTILATION. The unaided movement of air into and out of an enclosed space through intentionally provided openings, such as open windows and doors.

NITRIC OXIDE (NO). A colorless gas, formed during combustion, that is irritating to skin, eyes, and respiratory tract.

NITROGEN DIOXIDE (NO₂). A reddish-brown gas formed through combustion that is highly irritating and damaging to the respiratory tract.

NITROGEN OXIDES (NO_x). The class of compounds including nitrogen dioxide and nitric oxide that are formed through combustion.

ORGANICS. Chemical compounds that contain carbon and hydrogen, with or without oxygen, nitrogen, or other elements.

PARTICLES. Matter in which solid or liquid substances exist in the form of aggregated molecules. Airborne particulate matter typically range in size from 0.01 to 20 micrometers.

RADIONUCLIDE. An unstable nucleus of an element that decays or disintegrates spontaneously, emitting radiation.

RADON (RADON-222). A chemically inert gas that undergoes radioactive decay by emitting an alpha particle.

TOTAL SUSPENDED PARTICLES. The weight of particulate matter suspended in a unit volume of air.

VENTILATION. The process of supplying and removing air by natural and/or mechanical means to and from any space.

WORKING LEVEL (WL). One working level of radon-222 daughters will give out alpha particle energy of 1.3×10^5 MeV in one liter of air upon decay to lead-210.

WORKING LEVEL MONTH (WLM). Exposure to 1 WL for a working month of 173 hours.

Section 2

AIR EXCHANGE: INFILTRATION AND VENTILATION

IN THIS SECTION: Definition of infiltration and ventilation; how and where infiltration occurs; typical air exchange rates; energy costs of infiltration; infiltration-reduction techniques; existing ventilation standards.

BASIC ISSUES

All buildings exchange indoor air with outdoor air. Air passes through cracks in the foundations, walls, window frames, and through countless other openings in the shell of the building. Air is also exchanged by mechanical exhaust fans generally installed in kitchens and bathrooms, and by open windows and doors. Although the exchange of air helps flush odors and pollutants generated in the house to the outside, at the same time, it can bring dust and pollutants that are generated outdoors into the structure. Air exchange also results in a sizable transfer of heat across the shell of a building--a loss that accounts for 11% of the total annual energy consumption of the nation.¹ Reducing air exchange is one of the most effective means of reducing energy use in buildings, and is accomplished through ordinary measures such as caulking and weatherstripping in existing buildings, and by employing special sealing techniques in new construction. The potential conflict, however, is that as the air exchange is lowered, less outdoor air is available to dilute the concentration of any pollutants present in the house. In general, such tightening measures as caulking and weatherstripping should not lead to serious problems, particularly where none existed before; however, strategies that substantially reduce air exchange can cause significant deterioration of indoor air quality if special measures are not adopted (such control strategies are presented in Section 8). This section is concerned with air exchange--where and how it occurs, how it affects energy efficiency, what are its typical values, and what are current ventilation standards and their limitations.

INFILTRATION AND VENTILATION

It is important to distinguish between the two mechanisms of air exchange, infiltration and ventilation. The uncontrolled leakage of air through cracks and other openings in the shell of a building is called infiltration. (Technically, infiltration is the incoming air and exfiltration the corresponding outgoing air, but, because they are equivalent, the term infiltration is commonly used for both.) The air intentionally supplied by opening windows and doors or by mechanical means (ducts and fans) is referred to as ventilation. In conventional houses, the air needed for maintaining indoor air quality--that is, for removing odors from household activities, providing combustion air for furnaces, and removing excess moisture--is provided in a haphazard fashion by infiltration. In tight houses, where infiltration has been drastically reduced to improve energy efficiency, mechanical ventilation strategies are often employed.

How and Where Infiltration Occurs

Infiltration occurs as a result of temperature and wind-driven pressure differences between the inside and outside of a house. In winter, warm air inside the house rises and escapes out of cracks in the upper part of the house, drawing cold air into the lower parts. Wind drives air into a house on the upwind side and draws air out on the downwind side.

Air flows through countless cracks and openings in the shell of a building. New cracks form as the house ages and materials shrink and pull apart, as the foundation settles, or if earthquake or other forces have caused the structure to shift. Often, leaks occur around windows and doors, where materials tend to not fit properly and original sealants age and wear away. The connection between a concrete or masonry foundation and a wall structure of dissimilar material is a major leakage area. Other areas include penetrations made in the walls, ceilings, and floors to allow passage of wires, ducts, pipes, etc., as well as leaky dampers in fireplaces, recessed ceiling light fixtures, attic hatches, and baseboard molding. Figure 2-1 illustrates these common infiltration sites in a house.

Few measurements have been made to determine where the most significant leaks are, but researchers at Princeton University, in studying houses in the Northeast, have identified attic bypasses (any path in the walls that connects heated basements or living spaces with attics) as major sources of air leakage. Measurements on houses in the southern and western regions of the United States have shown that fireplaces without dampers and leaky ductwork are two dominant sources of air infiltration.

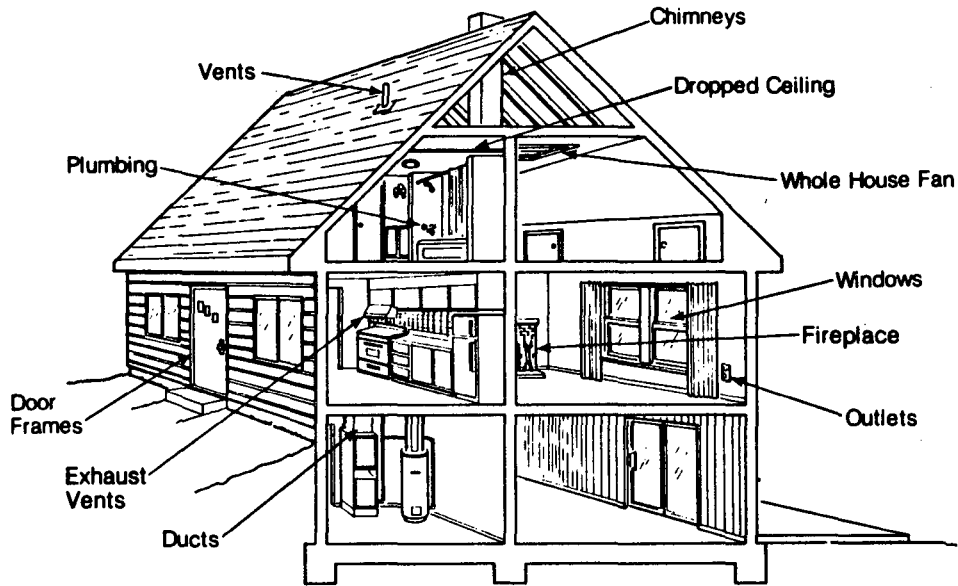

Figure 2-1. Infiltration sites

Table 2-1, based on the measurements from these houses, gives the percentage contribution to total leakage for major building components, and the typical range for each.

Table 2-1
COMPONENT AIR LEAKAGE VALUES

<u>Component</u>	<u>Range</u>	<u>Average</u>
Walls/floor	18-50%	35%
Ceiling	3-30%	18%
Heating system	3-28%	15%
Windows/doors	6-22%	15%
Fireplace	0-30%	12%
Vents	2-12%	5%
		100%

Typical Air Exchange Rates

The term air exchange rate is defined as the number of times the volume of air in a space is exchanged with outside air in a given period of time; usually expressed as "air changes per hour" or "ach". For a typical house (1500 ft² floor plan with 8-foot ceilings) an air exchange rate of 1.0 ach means that 12,000 ft³ of outdoor air (about half a ton) is exchanged with the inside air every hour. Air exchange rates in houses have been measured as low as 0.1 ach and as high as 4.0 ach. Rates in the same house may vary enormously from day to day and even hour to hour, depending on the speed and direction of the wind and the temperature difference between indoors and outdoors. Figure 2-2 shows the variability of the air exchange rates in a house. A house does not have a single infiltration rate unless weather conditions are specified.

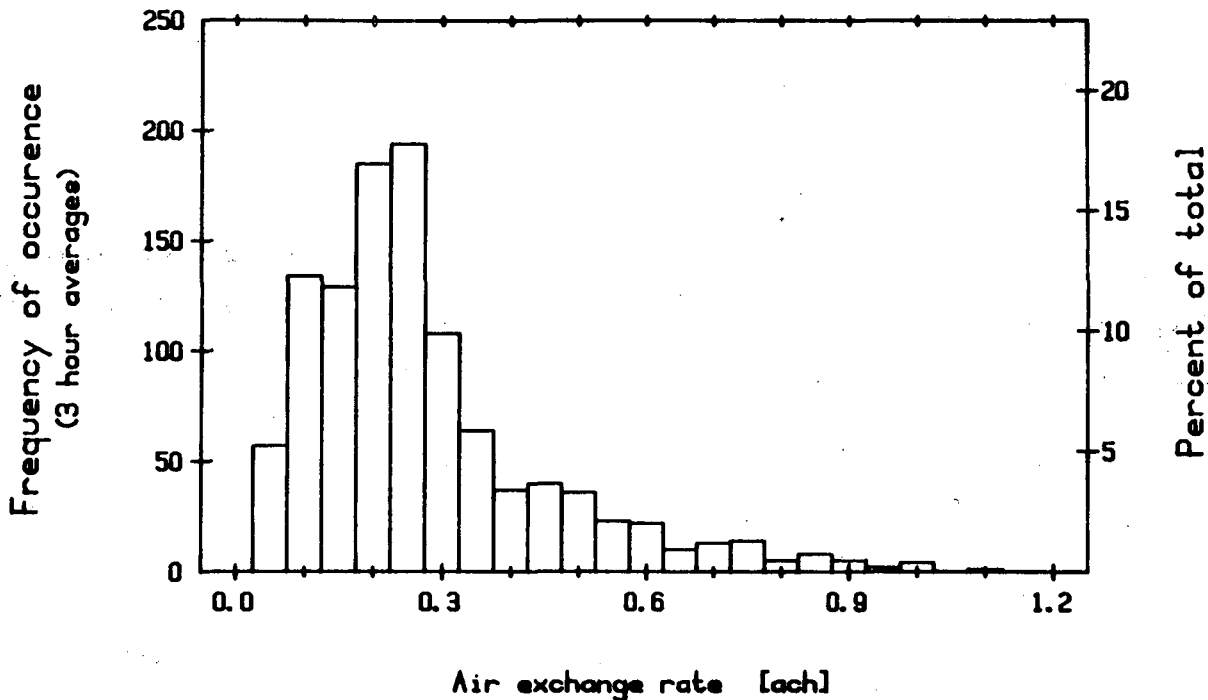

Figure 2-2. Variations in air exchange in a Chicago house

Infiltration rates from two recent surveys of U.S. houses are given in Figure 2-3. The top graph is from a sample of 312 houses recently constructed in the United States and Canada. The values shown are calculated averages of the infiltration rates over the heating season, November through March. The mean of the seasonal infiltration values is 0.63 ach. A better measure of this skewed distribution is the median, 0.50 ach. Fully 50% of the houses in this sample have infiltration values below the value frequently used as an acceptable lower limit of ventilation

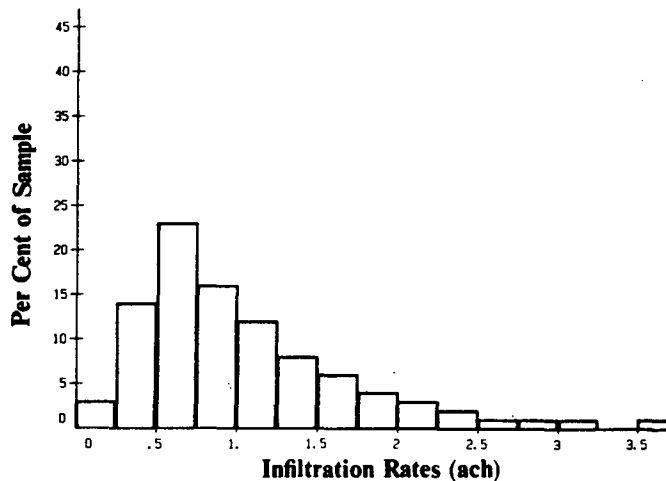
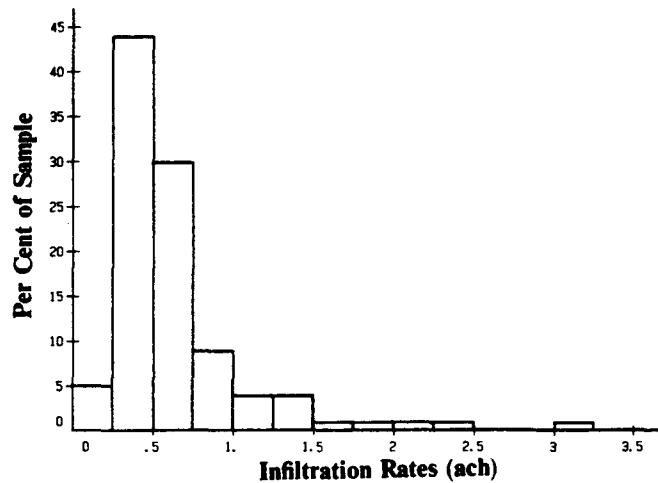

Figure 2-3. Infiltration rates in U.S. houses

for houses. The lower graph shows infiltration rates measured in 266 low-income houses throughout the United States. The mean value here is 0.9 ach. The broader distribution is partly because single measurements were taken of each house (not seasonal averages) and the higher mean is partly because these houses are typically older, poorer-quality construction than the other sample.

Energy Costs of Infiltration

There is a trend towards tighter construction as a result of builders' compliance with increasing consumer preference for energy-efficient houses. Builders today can construct houses that have air exchange rates as low as 0.1 ach. In these "super-tight" houses, mechanical ventilation is used to reduce moisture and odor build-up. The energy savings from reducing infiltration are quite significant. The values on the map in Figure 2-4 represent the heating load due to infiltration for various parts of the country.

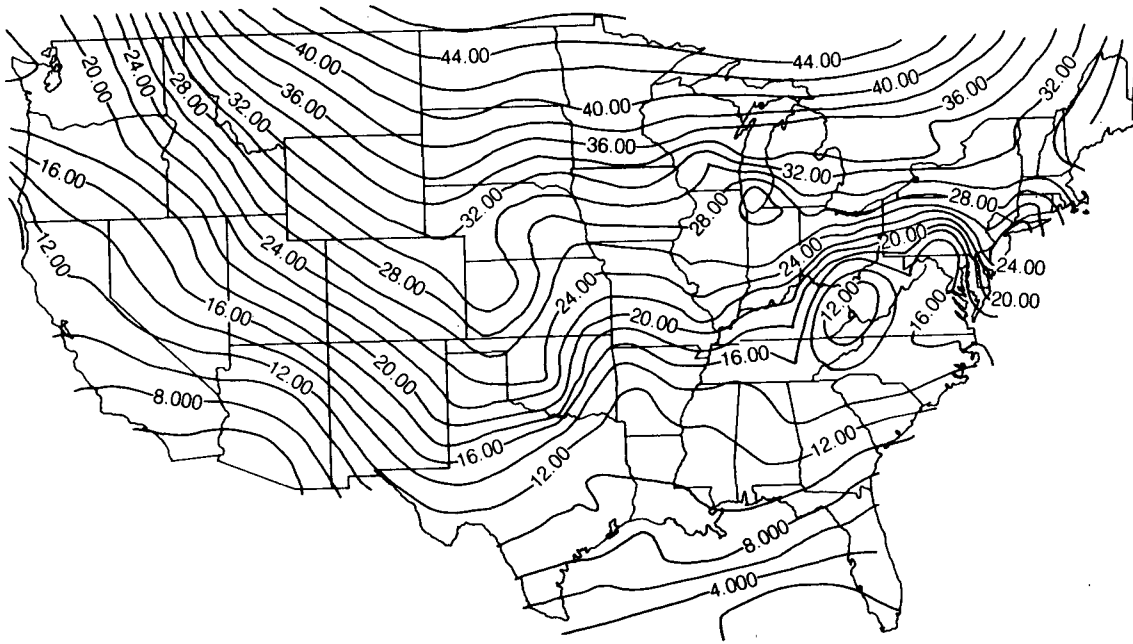

Figure 2-4. Heating season infiltration load for U.S.
 [1 Mjoule/cm² = 1.8 kWh/in²]

As an example, consider an all-electric house, recently caulked and weatherstripped, with a new tight-fitting damper installed in the fireplace, located in Minneapolis. Using blower-door pressurization techniques (described in Section 7), leakage areas were calculated before and after the tightening measures were carried out. The term leakage area is used to designate the approximate sum of all the leaks and openings in the shell of the building, and can be considered to be proportional to the infiltration rate. The results from these tests showed a reduction in the leakage area of 500 cm² (77 in²). Figure 2-4 gives a value of 36.0 megajoules per centimeter (Mjoules/cm²) for Minneapolis. Multiplying the reduction in leakage area by the heating season infiltration load gives 18,000 Mjoules, or 5,000 kWh (1 kWh = 3.6 Mjoules). Multiply this figure by the efficiency of the heating system (1.0 for electric resistance heater) and the price of electricity (\$0.074/kWh) to get the annual savings due to reducing infiltration--in this case, \$370. Given the leakage area, the heating system efficiency, and the price of electricity or fuel, similar calculations can be carried out for different locations.

Infiltration-Reduction Techniques

New Construction. Special techniques for reducing air infiltration are now being used by home builders. The installation of a continuous plastic sheet (called a "vapor barrier" or "vapor retarder") inside the walls on the warm side of the insulation is one of the most effective ways of reducing air leakage through walls and around window and door frames. In wood-frame houses, builders install the plastic film on the inside of the studding, overlapping and taping the sheets where the walls meet the floor and ceiling, and around door and window frames. Special sealants and careful application are required to ensure air tightness.

Another technique uses a polymeric-foam sealant to seal the cracks and holes that are made during construction to allow for plumbing and electrical work. When sprayed into the openings, the foam expands and forms a tight seal. Other areas that require meticulous application of caulks and sealants are openings around vents, ceiling light fixtures, fireplaces, and furnace registers.

Existing Buildings. Several strategies can be used to reduce infiltration in existing conventionally built homes, but it is rare that such measures can seal a house as effectively as the previous techniques employed during construction. These retrofit measures include caulking and weatherstripping doors and windows, installing foam gaskets behind outlet boxes, taping and sealing leaky ducts, adding plugs to fireplaces, and other techniques involving sealing. Although several studies report reductions in leakage area following weatherization, there are almost no measured infiltration data confirming such reductions. A weatherization study of 19 houses in Walnut Creek, California, showed a 25% average reduction in leakage area following one day of caulking and leak-plugging at each residence.² Results from other studies^{3,4} suggest an average reduction in leakage area of 20 to 30%, with a range for individual houses of 0 to 60%.

VENTILATION STANDARDS

Standards for ventilation rates in buildings have been set since the early nineteenth century. In 1824, Tredgold proposed that four cubic feet per minute (cfm) per person of outdoor air was necessary for removing CO₂ from enclosed spaces.⁵ By 1893, the accepted minimum ventilation rate was 30 cfm per person, based on Billings' recommendations for control of other unknown contaminants,⁶ and this standard was adopted by the American Society of Heating and Ventilating Engineers (ASHVE) and incorporated in the codes of 22 states by 1925.

The research by Yaglou et al. in the 1930s determined a minimum ventilation rate of 10 cfm per person for odor-free environments, and this value was adopted by the American Standards Association (ASA) in 1946.⁷ In 1973, the American Society of Heating, Refrigerating and Air-Conditioning Engineers (ASHRAE) revised the ASA odor-based standard and reduced the required ventilation rate to 5 cfm per person for energy conservation; at the same time, ASHRAE recommended values for comfort or odor-free environments that were two or three times greater than these minimum values. This standard was adopted by the American National Standards Institute (ANSI, formerly ASA) in 1977 and designated ANSI Standard B 194.1.

Currently, the two primary sources for ventilation standards in residences are ASHRAE Standard 62-1981: "Ventilation for Acceptable Indoor Air Quality" and the U.S. Department of Housing and Urban Development (HUD) Minimum Property Standards (MPS). At present, the ASHRAE standard is voluntary (except where adopted by state building codes) and the HUD standard applies only to housing financed through the Federal Housing Administration (FHA).

The 1979 revisions to the MPS allow ventilation to be achieved by infiltration rates of 0.5 ach plus natural ventilation through operable windows, which must have a total area of at least one-twentieth of the floor area of the room. ASHRAE Standard 62-1981 specifies 10 cfm (5 liters per second, l/s) per room for spaces other than bathrooms and kitchens, for which values are set at an installed capacity of 50 and 100 cfm (24 and 47 l/s) per room, respectively. With the kitchen and bathroom exhaust fans used several hours per day, the total ventilation rate for the house will be ~0.4 - 0.5 ach. Although the ventilation rates are specified differently in these voluntary standards, the results are intended to be equivalent. Moreover, the 1979 revisions to the MPS and the values in Standard 62-1981 are in close agreement with values recommended internationally. Table 2-2 gives current 1981 ASHRAE standards.

LIMITATIONS OF VENTILATION STANDARDS

Standards for ventilation rates can have either performance criteria, or prescriptive criteria. A performance standard specifies the quality of air that must be achieved, but says nothing about the means for achieving it. Performance criteria, to some extent, are now specified for certain industrial environments. Specifications for maximum allowable concentrations and time-weighted averages have been developed to protect workers from potential industrial health hazards. Generally, methods for achieving these criteria are not specified, and the responsibility to provide and maintain acceptable conditions resides with the owner and worker. For non-industrial, non-workplace (i.e., residential) environments, ventilation

Table 2-2

VENTILATION STANDARDS FOR DWELLINGS

U. S. Standards
ASHRAE 62-1981

	<u>Minimum cfm/Room</u>
General living areas	10
Bedrooms	10
Kitchens	100
Toilets, Baths	50
All other rooms	10
Basements, utility rooms	NA

Proposed Nordic Standards^a

	<u>Basic Ventilation</u>		<u>Supplementary Ventilation</u>
	<u>Outdoor Air</u>	<u>Exhaust Air (1/sec)^b</u>	
Dwelling as a whole	0.5 ach		
Bedroom	0.5 ach, 4 l/sec/ person		Operable window
Living room	0.5 ach		Operable window
Kitchen		10	Operable window and range hood (30-100 l/sec)
Bath		10	Operable window or adjustable ventilator with capacity of 30 l/sec
Toilet		10	

^aNKKB, Forslag till Nordiska riktlinjer for byggnadsbestämmelser rörande "LUFTKVALITET" (proposed Nordic guidelines for building codes: air quality), Stockholm, Sweden, October 1, 1979.

^b1 l/s \cong 2 cfm.

standards are usually prescriptive. A prescriptive standard specifies the ventilation rate for certain occupancy conditions in cfm per person or per unit area, or by air exchange rates, and makes no mention of the quality of the air that must be maintained.

Prescriptive values are established to meet objective and subjective criteria. Objective criteria are those designed to ensure sufficient oxygen for normal respiration, to dilute contaminants within the occupied space, and to dissipate thermal loads in the structure. Subjective criteria are those having to do with perceptions of odor intensity and odor acceptability. Test populations show wide variability on the threshold (just detectable) levels for a given odor or contaminant. Moreover, combinations of odors are not additive, and behavioral responses to combined odors are not well known.

Standards such as the ASHRAE Standard 62-81 are considered by some as relying on an insufficient data base of (1) pollutant levels in buildings, (2) the health effects caused by exposures to those pollutants, and (3) nonventilation control methods. Although these standards are not viewed as definitive, they are based on the best information currently available. As more knowledge is gained, these standards will be revised and updated.

REFERENCES

1. D. Lord, "Indoor Air Pollution, Energy Conservation, and the Use of Building Materials," Thermal Insulation, Materials, and Systems for Energy Conservation in the '80s, ASTM STP 789, F.A. Govan et al., eds., Philadelphia: American Society for Testing and Materials, 138-145, 1983.
2. J.B. Dickinson, R.D. Lipschutz, B. O'Regan, and B.S. Wagner, "Results of Recent Weatherization Retrofit Projects," Lawrence Berkeley Laboratory report, LBL-14734, July 1982.
3. J. V. Berk, R.A. Young, S.R. Brown, and C.D. Hollowell, "Impact of Energy-Conserving Retrofits on Indoor Air Quality in Residential Housing," Lawrence Berkeley Laboratory report, LBL-12189, January 1981.
4. F.J. Offerman et al., "Residential Air-Leakage and Indoor Air Quality in Rochester, New York," Lawrence Berkeley Laboratory report, LBL-13100, June 1982.
5. T. Tredgold, The Principles of Warming and Ventilating--Public Buildings and Dwelling Houses. London: J. Taylor, 1824.
6. J.S. Billings, Ventilation and Heating. Engineering Record, New York, 1893.
7. C.P. Yaglou et al., "Ventilation Requirements," ASHRAE Transactions 42, 133-163, 1936.

Section 3
INDOOR AIR QUALITY

IN THIS SECTION: Characterization of air and air pollutants; pollutant variation and distribution; factors affecting indoor air quality.

BASIC ISSUES

The air we breathe is made up of a mixture of gases, approximately 21% oxygen, 78% nitrogen, 1% argon, and 0.03% carbon dioxide. It contains trace amounts of other gases plus varying amounts of water vapor and small quantities of microscopic and submicroscopic solid matter, sometimes called "permanent atmospheric impurities". The concentrations of these impurities--the result of wind erosion, sea spray evaporation, and volcanic eruption--varies considerably but are usually below those associated with man-made activities. Man-made pollution originates from power-generating plants, various modes of transportation, industrial processes, mining and smelting operations, construction, and agriculture. Whereas outdoor pollution has been studied and characterized for decades, indoor air, as it is affected by pollutants in outdoor air and, in particular, by pollutants generated indoors, has been a topic of research only in the last decade.

CHARACTERISTICS OF AIR POLLUTANTS

Any compound having a concentration in air large enough to have undesired effects is considered to be a pollutant. Such compounds can be particulate or gaseous, organic or inorganic, visible or invisible, submicroscopic, microscopic, or macroscopic, and toxic or harmless. Classifications commonly employed are: 1) particles, and 2) vapors and gases.

With the exception of radon, the concentration of a pollutant is usually expressed in one of two ways: either in volume per unit volume of air or in mass per unit volume of air. In the first case, the unit of measurement is the ratio of the two volumes, expressed, for example, as one part pollutant per million parts air (or parts per million, ppm). In the second case, the mass of the pollutant is expressed

in metric units as microgram pollutant per cubic meter air ($\mu\text{g}/\text{m}^3$) or nanogram per cubic meter (ng/m^3). The first measure is used exclusively for gaseous pollutants, the second for both gaseous and particulate pollutants.

The concentration of radioactive materials--substances (like radon) that emit alpha, beta, or gamma radiation as they disintegrate--are expressed in terms of quantity and concentration. The common units of quantity, the curie (English) and the becquerel (SI), represent a given number of disintegrations per second (see Glossary). Because the curie expresses relatively large quantities, the more common unit is the picocurie, or 10^{-12} curies. The concentration is generally expressed in picocuries per cubic meter (pCi/m^3). The corresponding SI unit is the Bq/m^3 .

FACTORS THAT INFLUENCE INDOOR AIR QUALITY

The quality of indoor air is affected by interactions among the outdoor air, building design and construction, indoor activities, and building occupants. Each of these factors, in turn, varies from time to time, location to location, and individual to individual. Often the extent of the variability of inherent properties of buildings, people, and items is not known. Furthermore, in many cases the impact of the environment on these properties is not precisely known. Figure 3-1 shows how these different factors influence indoor air quality, using combustion appliances as an example.

Variation in Time

The concentration of a pollutant changes because both the source emission rate and the removal rate vary with time. Some sources emit contaminants continuously, others sporadically. Radon gas emissions from the soil may be continuous but vary considerably, depending on the moisture content of the soil, temperature, barometric pressure, and wind speed. Sporadically operated appliances, such as gas stoves, generate pollutants over discrete intervals of time; these rates also vary depending on burner tuning, flame temperature, and the type of pot on the burner. Some sources, such as particleboard, which contains urea-formaldehyde glues, can have high initial emission rates of formaldehyde that decrease over time, but also vary with changes in temperature and humidity.

The removal of contaminants can also be sporadic or continuous. The operation of an exhaust fan in a kitchen range hood is an example of the former; the attachment of particles to the walls and furnishings of a room is an example of the latter.

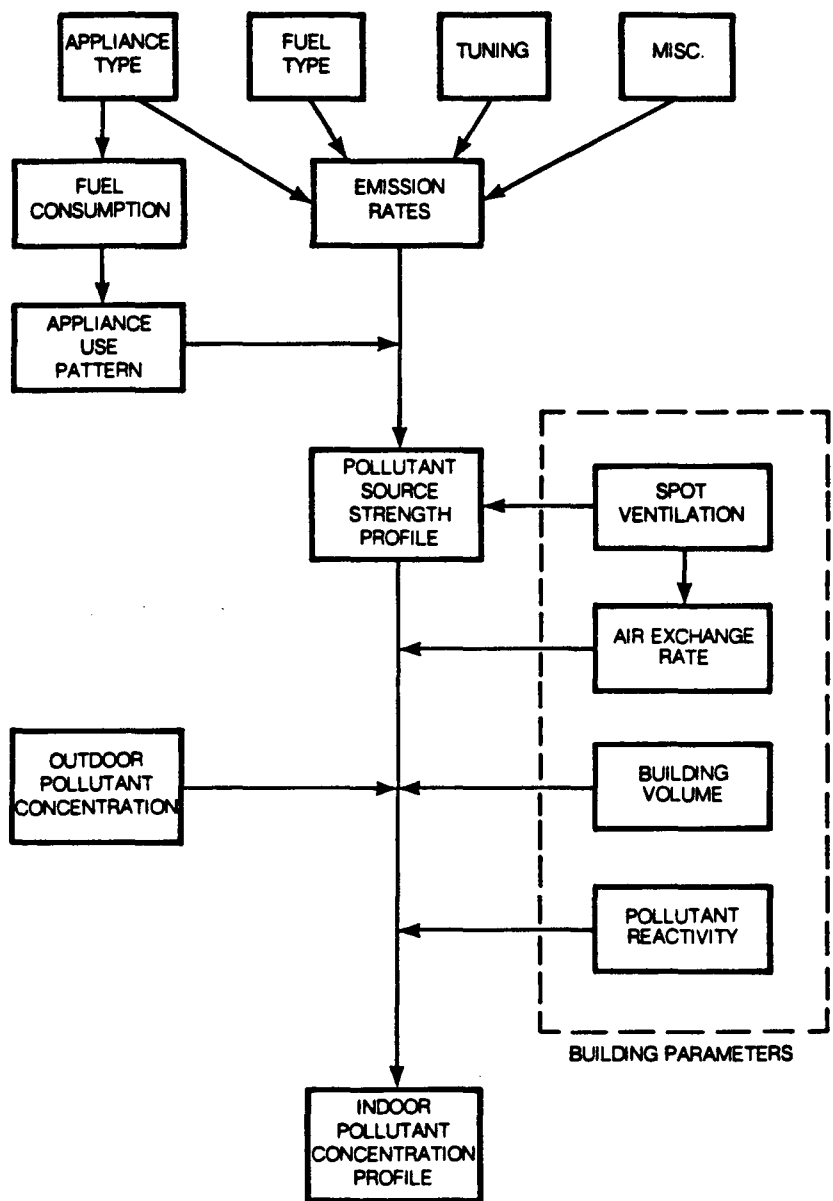

Figure 3-1. Factors affecting indoor pollutant concentration

Variation in Space

The concentration of a pollutant, depending on its type, source, and the mixing conditions in the enclosed space, can vary significantly even within a small area. In a study of 135 homes having gas stoves, measured values for nitrogen dioxide were twice as high in kitchens as in bedrooms.¹ Radon concentrations in a single house can vary by a factor of ten over a few days.² Air contaminants are distributed by both diffusion and forced convection. Diffusion is the spontaneous scattering of particles and molecules caused by their natural small-scale (Brownian) motion, with movement from regions of high concentrations to regions of low concentrations. Forced convection is the transport of particles and molecules by bulk movement of air. Convection will tend to dominate pollutant movement because it involves large volumes of air throughout the space. This would be the case with a forced-air heating system, although such systems are rarely operated on a continuous cycle.

SOURCES OF INDOOR POLLUTANTS

The sources of indoor pollutants are diverse. They may be outside or inside the building, or they may be an integral part of the building. They may be controllable or uncontrollable. They may be quite obvious or go undetected. Their emission rate may be constant or variable. Table 3-1 lists the major sources of indoor air pollution (both indoor and outdoor) and some of the important pollutants they emit.

Outdoor Sources

The environment surrounding a residence is often a source of air contaminants, which are produced by natural events, industrial processes, and automobile exhaust. Urban areas have large concentrations of these contaminants. In rural areas, suspended organic material and contaminants resulting from crop spraying may also enter from outside. Certainly, one's proximity to major pollution sources influences exposure to pollutants, both indoors and outdoors.

Although outdoor-generated pollutants will penetrate a building's envelope to varying degrees, measurements have shown that the building's envelope generally acts as a screen to outdoor pollutants, particularly to sulfur dioxide (SO_2) and ozone (O_3). A study that compared indoor and outdoor concentrations of selected pollutants at ten residences showed that SO_2 and O_3 concentrations were consistently higher outdoors than indoors. On the other hand, CO_2 and non-methane hydrocarbons levels were consistently higher indoors,³ as were concentrations of total suspended particles, which were much higher in residences where occupants smoked.

Table 3-1

SOURCES AND TYPES OF INDOOR AIR POLLUTANTS

<u>Sources</u>	<u>Pollutant</u>
OUTDOOR	
Ambient Air	SO ₂ , NO, NO ₂ , O ₃ Hydrocarbons, CO, Particulates
Motor Vehicles	CO, Pb, Hydrocarbons, Particulates, NO, NO ₂ , SO ₂
INDOOR	
Building Construction Materials	
Concrete, stone	Radon
Particleboard, Plywood	Formaldehyde
Insulation	Formaldehyde, Fiberglass
Fire Retardant	Asbestos
Adhesives	Organics
Paint	Mercury, Organics
Building Contents	
Heating and cooking combustion appliances	CO, CO ₂ , NO, NO ₂ , Formaldehyde, Particulates, B(a)p
Furnishings	Organics
Water service; natural gas	Radon
Human Occupants	
Metabolic activity	H ₂ O, CO ₂ , NH ₃ , Odors
Human Activities	
Tobacco smoke	CO, NO ₂ , Organics, Particulates, Odors
Aerosol spray devices	Fluorocarbons, Vinyl Chloride, Particulates
Cleaning and cooking products	Organics, NH ₃ , Odors, Particulates
Hobbies and crafts	Organics, Particulates

Indoor Sources

Several features of a building present potential sources of contaminants, including the envelope design, the arrangement and furnishing of interior rooms, and the environmental control systems (heating and air conditioning).⁴ Figure 3-2 shows a few of the potential sources of indoor pollutants.

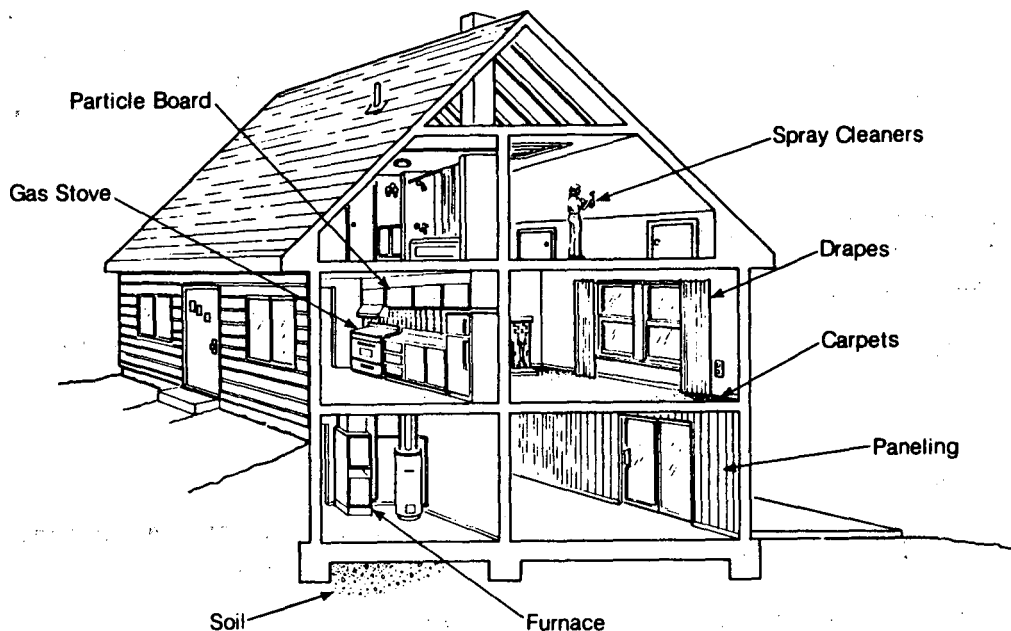

Figure 3-2. Sources of pollutants

Common building materials such as plywood and particleboard are made with formaldehyde-containing resins. Both particleboard and plywood are commonly used for subflooring, and plywood is a standard sheathing material. Urea-formaldehyde foam insulation, if improperly installed, will outgas formaldehyde. Plastics, which may be used in place of windows, degrade slowly and outgas organic and inorganic vapors. Solvents from paints evaporate and contaminate the indoor air. Certain soils under houses emit radon, as to a lesser extent do concrete and masonry.

The heating and air-conditioning systems also affect air quality. Forced-air systems aid in pollutant transport by distributing pollutants throughout the house. Combustion of wood, coal, gas, or oil for heating may contaminate the air indoors as well as outdoors. Fireplaces and unvented kerosene space heaters produce carbon monoxide and nitrogen oxides, as well as suspended particles. Unvented gas space heaters emit combustion products directly into the rooms in which they are used.

Ordinarily, gas furnaces produce little or no indoor pollution because the exhaust is vented directly outdoors. Potential problems occur when there is a cracked heat exchanger or blocked flue, and pollutants enter the living space. Sometimes, exhaust fans in different parts of the house, or even a fireplace, can produce a negative pressure on the inside of the house, that can draw the combustion pollutants back inside.

Any feature that affects infiltration will also affect the quality of the air indoors. Continuous vapor barriers, use of special sealants, the quality of doors, windows, and weatherstripping, and the general quality of construction will all determine to some extent the removal of pollutants by air exchange. In addition, the orientation of the building to the wind and the degree of shielding provided by trees, hedges, and other buildings all modify the infiltration rate.

Occupant Activities

Occupant activities that affect indoor air quality include not only the type and intensity of activities, but the location and frequency of these activities. Smoking, cleaning, and cooking generate gaseous and particulate contaminants indoors.⁵ Some chemicals used for cleaning, pest control, and various hobbies evaporate into the indoor air. Occupants also determine the extent to which environmental and other control systems are used, and their patterns of opening doors, windows, and vents as well as running exhaust fans and using fireplaces all change the quality of the air indoors.

CONCLUSION

Because of their diversity and the number of variables affecting their source strength and distribution, indoors, known contaminants of indoor air are difficult to characterize. The situation is confounded by the presence of multiple sources and removal mechanisms acting at the same time. For example, the variation by a factor of one thousand that has been observed in studies of indoor radon concentrations cannot be fully accounted for by variations in air exchange, which span only a factor of ten. The extent to which a given characteristic influences air quality is not easily determined, and cannot be predicted with confidence. At present, each residence must be assessed individually to determine whether existing removal mechanisms are sufficient to maintain acceptable air quality in spite of any pollutant sources that may be present, or whether specific remedial actions need to be taken.

REFERENCES

1. J.D. Spengler et al., "Sulfur dioxide and Nitrogen Dioxide Levels Inside and Outside Homes and the Implications on Health Effects Research," Environmental Science Technology 13, 1276-1280, 1979.
2. D.T. Grimsrud et al., "Continuous Measurement of Radon Entry in a Single Family House," Lawrence Berkeley Laboratory report, LBL-15839, June 1983.
3. "Air Quality in the Home," Energy Analysis and Environment Division, EPRI Journal May 1983, p. 7.
4. I. Andersen et al., "Indoor Air Pollution due to Chipboard Used as a Construction Material," Atmospheric Environment 9, 1121-27, 1975.
5. J.D. Spengler et al., "Long-term Measurements of Respirable Sulfates and Particles Inside and Outside Homes," Atmospheric Environment 15, 23-30, 1981.

Section 4
INDOOR AIR POLLUTANTS

IN THIS SECTION: Key indoor pollutants identified and characterized; sources; concentrations; results of field studies.

BASIC ISSUES

The pollutants of most concern in residential buildings are radon, formaldehyde, and certain combustion products (nitrogen dioxide, carbon monoxide, carbon dioxide, and respirable particles). Even though their health effects in many cases are only now being systematically documented, these pollutants have been singled out by the World Health Organization, National Academy of Sciences, and other research communities because they are suspected of being common in homes, and because high indoor concentrations have been measured. The reader should not infer any priority to the order in which the pollutants are described here, for to attach priorities would require an understanding of relative health effects (and synergistic effects) that we do not have. The health effects associated with these pollutants are discussed in Section 5. Here, we present the key facts about each of the pollutants or pollutant category named above, describing their sources and behavior as well as results of field studies.

RADON

Radon, a radioactive, chemically inert gas, is an intermediate product in the decay chain of radium, which is part of the uranium-238 decay chain and can be found in small concentrations in common rock and soil. The most abundant radon isotope, radon-222, has a relatively long half-life of 3.8 days; it decays into polonium-218 (Figure 4-1), which also decays radioactively (these decay products of radon are known as radon daughters).

Succeeding members of the decay sequence (except lead-210) have much shorter half-lives (higher radioactivities) and are physically and chemically active. They usually attach themselves to fine particles in the air, and may be retained in the respiratory system.

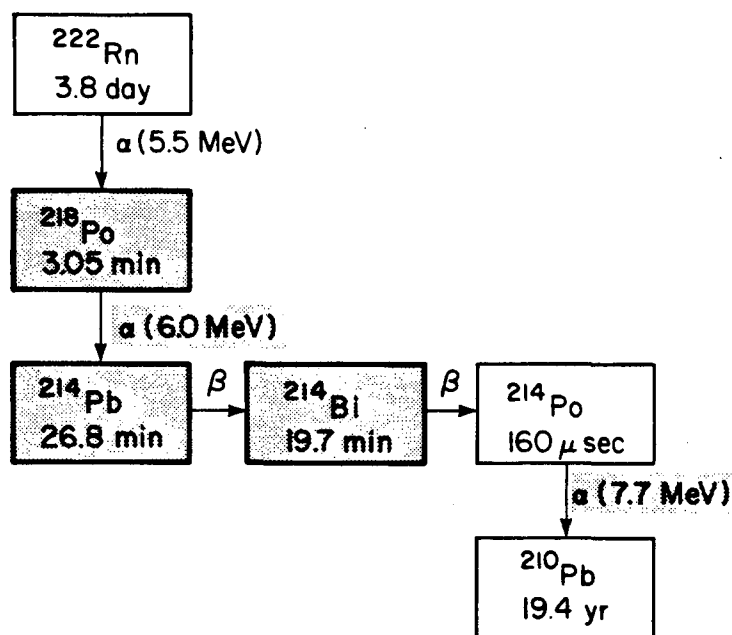

Figure 4-1. Radon decay chain

Radon can enter a building in the following ways (Figure 4-2): by transport from soil around the foundation through cracks and openings in the structure; through emanation from earth-derived building materials such as concrete; and via spring or well water.

The presence and concentration of radon in a residence depends on several factors: the geographical location of the building, the materials used to construct it, its foundation type, the presence of pathways for air transport from soil to basement, the water supply source, and the ventilation rate of the house. In those cases where there was reason to be concerned about radon levels, studies indicate that the soil under a house is probably the principal contributor to indoor radon concentration.¹ Measurements taken in living spaces of homes throughout the United States show that concentrations of radon vary over nearly three orders of magnitude (0.1-50 picocuries/liter);² (see figure 4-3). Typical values averaged over the year are in the range of 0.5 to 4 pCi/l. There are specific areas of the country where construction materials have been made out of uranium mill tailings or phosphate mining slag, both high in radium content. For example, phosphate slag has been used in the manufacture of insulation, and this insulation has been used in residences in the state of Washington. Additionally, phosphate slag was widely used from 1962-1977 as aggregate for the concrete foundation of homes built in southeastern Idaho.³

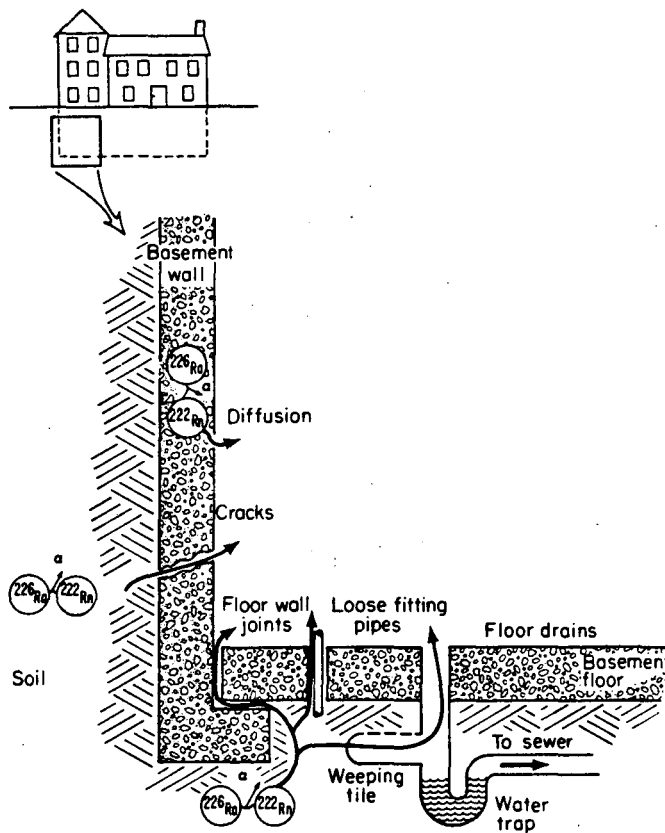

Figure 4-2. Primary pathways for radon entry into buildings

Other factors that have been found to be important in influencing the concentration of radon and its daughters in residences are the type of basement or foundation and whether groundwater is used for the domestic water supply (in which case radon concentrations may be relatively high). Houses having vented crawl spaces may have lower concentrations than those with unvented basements or built as slab-on-grade. Some evidence suggests that the mechanisms driving infiltration also drive radon entry. In this case, radon concentrations would appear to be largely independent of infiltration rate for any given house.

FORMALDEHYDE AND OTHER ALDEHYDES

Formaldehyde (HCHO), the simplest of the group of compounds classified as aldehydes, is a pungent, colorless gas the odor of which can be detected in quantities less than 0.1 mg/m^3 (81 parts per billion, ppb). Primarily an indoor-generated pollutant, its sources are building and insulating materials, furniture, and numerous consumer products. Formaldehyde is used in a wide variety of building materials, mainly in the urea, phenolic, melamine, and acetal resins present in insulation

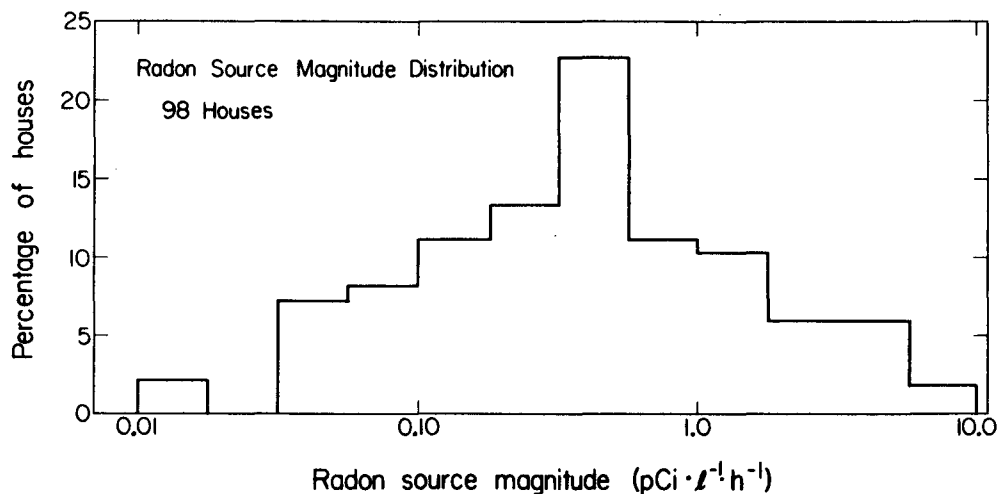

Figure 4-3. Frequency distribution for radon source magnitude for 98 houses

materials, particleboard, plywood, textiles, adhesives, and so forth.

Although building materials such as particleboard can emit formaldehyde continuously for a period of years, its emission rate is known to decrease with time. The half-life of the formaldehyde contained in particleboard has been measured, and found to vary considerably, depending on the specific manufacturing process. It is also known that an increase in humidity can increase formaldehyde's emission rate.

Insulation

Urea-formaldehyde (UF) foam has been used extensively in the past, both here and in European countries, as thermal insulation in the walls of existing residential buildings. It is injected into wall cavities through holes that are then sealed. Installation involves mixing partially polymerized UF resin with a foaming agent and an acid catalyst under pressure to force air into the mixture and thus create a foam. Some residual formaldehyde may enter the interior of the building and, under some circumstances, considerable amounts can be released.

Building Materials

The superior bonding properties and low cost of formaldehyde polymers have made them commercially attractive for use in the resins used to form such building materials as plywood and particleboard. In fact, urea-formaldehyde resin is the most common adhesive used in interior-grade plywood and particleboard. Interior-grade plywood, for example, is composed of several thin sheets of wood glued together with UF resin. Particleboard, on the other hand, is made by saturating small wood shavings with UF resin and pressing the resulting mixture into the final form. In buildings in which these wood products are used for subfloors, cabinets, partition walls, or furniture, formaldehyde can reach concentrations sufficient to cause irritation of the eyes and upper respiratory tract.

Combustion Processes

Formaldehyde is also produced during simple combustion processes associated with gas cooking and heating. Studies conducted in special environmental chambers have indicated that a poorly adjusted combustion appliance can contribute significant quantities of formaldehyde to the indoor environment.⁴

Field Measurements of Formaldehyde

Since 1978 a substantial number of residential buildings in the United States and in other countries have been monitored for formaldehyde and total aldehyde concentrations (Figure 4-4).

In a survey of mobile homes whose occupants complained about indoor air quality, concentrations as high as $2880 \mu\text{g}/\text{m}^3$ (2.4 ppm) of formaldehyde were found.⁵ Other surveys described a tightly built (0.2 ach average) energy-efficient house in Maryland where indoor formaldehyde concentrations exceeded $120 \mu\text{g}/\text{m}^3$.⁶ Studies undertaken in an energy-efficient house (0.4 ach average) located in California indicated that the presence and type of furniture can play a major role in influencing the ambient levels of formaldehyde indoors.⁷ The average HCHO concentration in the house, unoccupied and unfurnished, was $80 \mu\text{g}/\text{m}^3$ (65 ppb), which increased to $223 \mu\text{g}/\text{m}^3$ (181 ppb) when furniture was added. Formaldehyde levels were also measured in four energy-efficient houses (0.2 ach average at time of measurements) in Eugene, Oregon.⁸ With outdoor levels less than 3 ppb, weekly average indoor levels were 50, 55, 94, and 100 ppb, respectively, for the four houses.

⁸ A limit of $120 \mu\text{g}/\text{m}^3$ has been recommended by the Ministry of Health in The Netherlands and has been proposed in other nations.

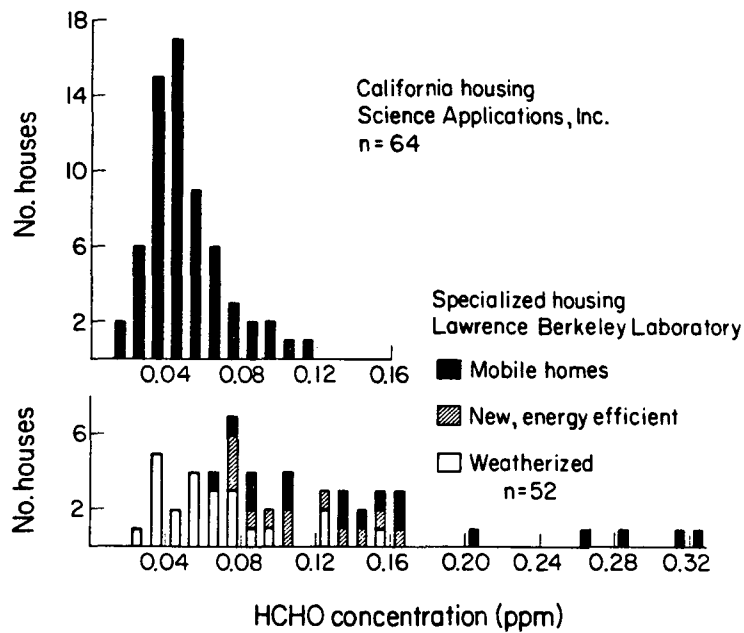

Figure 4-4. Residential formaldehyde concentrations

Interesting comparative data came from twelve houses in Midway, Washington, that were monitored for formaldehyde levels before and after weatherization.⁹ In general, formaldehyde levels were low, probably because these houses, being more than thirty years old, contained building materials that were old, and, as they were all-electric, had no combustion appliances. When new furniture was placed in one of these houses, however, an average HCHO level of 79 ppb was reported. When the furniture was moved to another house, the formaldehyde level there jumped from <5 ppb to 79 ppb, while in the original house it dropped to 13 ppb. (The outdoor HCHO concentrations were all below the detection limit of 5 ppb.)

COMBUSTION PRODUCTS

A wide range of combustion products can be emitted by indoor combustion appliances and cigarette smoke: carbon monoxide (CO), carbon dioxide (CO₂), water vapor (H₂O), nitric oxide (NO), nitrogen dioxide (NO₂), sulfur dioxide (SO₂), and formaldehyde (HCHO), as well as respirable particles. Common appliances found in residential buildings are gas-fired stoves, indoor gas-fired water heaters, unvented gas-fired space heaters, gas-fired furnaces, and portable kerosene-fired space heaters. Wood-burning stoves and fireplaces and coal- or wood-burning furnaces can also contribute

hydrocarbons and polycyclic organic matter (POM) in addition to the aforementioned pollutants. The combustion byproducts emitted by an automobile allowed to idle in an attached garage can gain entry to the living space of the house.

Gas Stoves

There have been many field studies monitoring the concentrations of various pollutants in residential buildings having gas stoves. In almost all cases, indoor levels of CO, NO₂, and NO have exceeded outdoor levels. In a number of cases, indoor levels comparable to existing outdoor air quality standards for NO₂ and CO have been reported. For example, NO₂ and CO concentrations in a kitchen of a suburban house in Connecticut during the winter averaged approximately 0.05 and 3.5 ppm, respectively.¹⁰ In a series of indoor air quality measurements taken at an unoccupied energy-efficient research house in California, CO and NO₂ were measured in several rooms during a period when the measured infiltration rate varied between 0.33 and 0.44 ach.¹¹ Based on "typical" gas stove operation taken from an American Gas Association study, peak one-hour average NO₂ levels in the kitchen and living room were 450 and 400 ppb, respectively, which exceeds the California one-hour outdoor standard of 250 ppb (470 µg/m³). The outdoor level of NO₂ was 70 ppb. The one-hour outdoor standard of 35 ppm for CO was not exceeded anywhere in the house, although the indoor CO concentration (a peak of 25 ppm in the kitchen) was much higher than outdoors.

Unvented Space Heaters

Several studies have been performed to assess the level of air contamination from unvented gas-fired and kerosene-fired space heaters. Experiments on a portable, convective-type kerosene space heater operated in a 27-m³ chamber showed that at a ventilation rate of 1.9 ach, CO and particle concentrations were low but CO₂ and NO_x concentrations were high.¹² After 45 minutes of operation, CO₂ concentrations reached 5000 ppm, the eight-hour occupational standard established by the U.S. Occupational Safety and Health Administration (OSHA), and NO₂ concentration was greater than 1 ppm over background, or four times the California peak one-hour outdoor standard.

Additional experiments with portable convective- and radiative-type kerosene heaters, also conducted in the 27-m³ chamber, found that CO₂ levels can reach 10,000 ppm when operating for one hour at a fuel consumption rate of approximately 8,000 Btu/hr and an air exchange rate of 0.40 ach. Under these conditions, NO₂ levels exceeded the California one-hour standard of 0.25 ppm--by a factor of seven for the convective heater and by a factor of two for the radiant model.¹³

Emissions from unvented gas-fired space heaters are highly dependent on the size of the heater, its design, and how the fuel-to-air mixture of the appliance is tuned. Eight heaters, ranging in size from 12,000 to 40,000 Btu/hr, were tested in the 27-m³ chamber, and their NO_x and HCHO emission rates were found to be lower than those associated with gas-fired stoves. CO and HCHO emission rates were found to be much more variable than other pollutants and, for some heaters, very sensitive to the state of tuning.¹⁴

Wood-Burning Stoves, Wood-Burning Furnaces, and Fireplaces

Several studies have shown that wood burning is a significant source of CO, NO_x, hydrocarbons, and respirable particles, including the carcinogenic polycyclic organic matter (POM) compounds. Laboratory and field measurements show that pollutant emission rates from wood combustion can vary over a wide range. For example, CO emissions can vary from 4 to 400 grams per kilogram (g/kg) of wood burned; particulate emissions from 0.5 to 63.5 g/kg; total hydrocarbons from 0.2 to 48.5 g/kg; NO_x from 0.2 to 7.3 g/kg; and POM from 0.004 to 0.37 g/kg.¹⁵

Field studies in three suburban residences in the Boston area indicate that wood burning produces elevated levels of total suspended particles (TSP), respirable suspended particles (RSP), and benzo-a-pyrene (a carcinogen).¹⁶ In an all-electric house with a closed combustion wood-burning stove in the basement and an average ventilation rate of 0.68 ach, over a two-week period TSP in the living spaces averaged 1.8 times the outdoor level on wood-burning days and exceeded the secondary 24-hr outdoor standard of 150 µg/m³ for TSP. RSP in the house averaged 1.4 times the outdoor level on wood-burning days. Two other residences that had wood-burning fireplaces exhibited much higher indoor/outdoor ratios for TSP and RSP during wood-burning days. Benzo-a-pyrene concentrations were measured in two houses and were found to be five and ten times the outdoor levels, respectively. Carbon monoxide, measured in one house only, was found to be at a higher concentration than outdoor levels during use of the wood stove, and, on one of the test days, reached a maximum of 5.5 ppm. It is important to note that even higher contaminant levels would certainly have been found if sampling occurred in the room where the wood stove was located.

Another study of three houses with wood-burning stoves and furnaces showed elevated levels of CO, NO_x, and SO₂ during the period when these appliances were operated, although the pollutant levels observed were generally below occupational and outdoor air quality standards.¹⁷ (Particles were not measured in this study.) During the test period, the average infiltration rates in these three houses--labeled House A, House B, and House C--were 0.30, 0.08, and 0.40 ach, respectively. Comparisons of

indoor pollution levels from wood-burning furnaces in houses A and C show that the magnitude of pollutant emissions from appliances vary, for reasons not identified. The major component of gaseous emissions also varies: the dominant pollutant from the wood-burning stove in House B was NO; from the wood-burning furnace in House A, CO; and from the wood-burning furnace in House C, NO₂. At this time, data on wood-burning appliances are very limited.

Tobacco Smoke

One of every three persons between the ages of 17 and 64 smokes cigarettes regularly. Surveys in eight cities show that from 54 to 76% of homes have one or more smokers.^{18,19} In addition, smokers and nonsmokers are often exposed to smoke at their workplaces and during social activities. Exposure to other people's tobacco smoke is now referred to as passive smoking. Closely connected to "active" and "passive" smoking are the terms "mainstream" and "sidestream" smoke. Mainstream smoke is the smoke drawn through the tobacco during inhalation, resulting in higher temperatures, more complete combustion, and a greater degree of absorption by the tobacco and, if present, the filter. Mainstream smoke accounts for approximately 4% of the total smoke produced. Sidestream smoke, defined as smoke arising from the smoldering tobacco, accounts for the majority (96%) of gases and particles produced. The composition of mainstream smoke exhaled by a smoker varies considerably depending on smoking behavior, burning temperature, and type of filter. Because of the length of the burn and the burn temperature, sidestream smoke is a more important source of local air contamination for many substances such as CO, nicotine, ammonia, and aldehydes, than mainstream smoke. The passive smoker, of course, does not receive nearly as large a dose of smoke as does the smoker.

A number of indoor air pollutants arise from tobacco smoke; some of the more important ones are particles, CO, benzo-a-pyrene, nicotine, nitrosamines, acrolein, and other aldehydes. Spengler and coworkers measured levels of respirable suspended particles (RSP) in 80 homes, with and without smokers, across six cities.²⁰ RSP levels were essentially the same (~23 µg/m³) indoors and outdoors in the homes without smokers. The mean RSP concentrations indoors for homes with one and two smokers were 43 and 75 µg/m³, respectively; however, 24-hr average indoor RSP concentrations frequently exceeded 200 µg/m³ in homes with cigarette smokers*. These data, collected

* The short-term (24-hour) EPA outdoor standard for total suspended particles (TSP) is 260 µg/m³. However, this standard may be inappropriate for particles emitted from cigarettes, as the size distribution and chemical composition are quite different from those of particles found in outdoor air.

over a three-year period, illustrate the significant contribution of cigarette smoke to indoor particulate concentrations.

Repace and Lowrey also measured of RSP in different types of buildings, again with and without the presence of smokers.²¹ The average RSP concentration in three residences was $24 \mu\text{g}/\text{m}^3$. One measurement, performed during a cocktail party in a house where two of the fourteen occupants were smoking, showed indoor RSP levels of $350 \mu\text{g}/\text{m}^3$. RSP concentrations measured in nonresidential buildings (restaurants, meeting halls, sports arenas, etc.) with smokers present ranged from 55 to $700 \mu\text{g}/\text{m}^3$.

Sidestream smoke was shown to be an important source of RSP in a study by Spengler et al.²² Portable monitors were carried by several persons for 12-hour periods on 15 sampling days. The mean RSP concentration of samples where participants were exposed to sidestream smoke was $40 \mu\text{g}/\text{m}^3$ compared to $22 \mu\text{g}/\text{m}^3$ for the nonsmoking, nonexposed participants. The outdoor concentrations averaged less than $15 \mu\text{g}/\text{m}^3$.

Finally, carbon monoxide levels measured in rooms where cigarettes were being smoked ranged from 12 ppm to 90 ppm (the EPA outdoor standard for eight-hour exposure is 9 ppm). Sebben et al. found CO concentrations greater than 9 ppm in restaurants and night clubs but, in most cases, the CO concentration remained below 35 ppm (the one-hour outdoor standard).²³

OTHER POLLUTANTS

There are many other indoor air pollutant sources that have not been specifically mentioned. Among these are insulating materials containing asbestos; household products such as paints, aerosols, and cleaning fluids that contain numerous organic compounds; cooking products such as greases, water vapor, and odorants; and people and their pets, both of which can be regarded as sources of bacteria, viruses, fungi, odorants, and water vapor. Research in indoor air pollution is continuing, and our knowledge of this subject is far from complete. As more studies are undertaken, more pollutants and sources are likely to be found. Some will be easily identified and can be remedied through standard control techniques. Others, more elusive or more persistent--such as asbestos--will inevitably require development of special control techniques.

REFERENCES

1. W.W. Nazaroff, M.L. Boegel, and A.V. Nero, "Measuring Radon Source Magnitude in Residential Buildings," Lawrence Berkeley Laboratory report, LBL-12484, Au-

gust 1981.

2. A.V. Nero, "Airborne Radionuclides and Radiation in Buildings: A Review," Lawrence Berkeley Laboratory report, LBL-12948, August 1981.
3. B. Peterson, "Field Surveys of Phosphate Slag Used for Construction Purposes in Idaho Springs, Idaho," Idaho Department of Health and Welfare, June 1979.
4. J.R. Girman, M.G. Apte, G.W. Traynor, and C.D. Hollowell, "Pollutant Emission Rates from Indoor Combustion Appliances and Sidestream Cigarette Smoke," Environment International 8, 213-221, 1982.
5. P.A. Breysee, "Formaldehyde Exposure Following Urea-Formaldehyde Insulation," Environmental Health Safety News 26, 1-12, 1978.
6. C.D. Hollowell et al., "Building Ventilation and Indoor Air Quality," Lawrence Berkeley Laboratory report, LBL-10391, January 1980.
7. Ibid.
8. R.D. Lipschutz et al., "Infiltration and Indoor Air Quality in Energy Efficient Houses in Eugene, Oregon," Lawrence Berkeley Laboratory report, LBL-12924, August 1981.
9. F.J. Offermann, J.R. Girman, and C.D. Hollowell, "Midway House Tightening Project: A Study of Indoor Air Quality," Lawrence Berkeley Laboratory report, LBL-12777, May 1981.
10. W.A. Cote, W.A. Wade, and J.E. Yocum, "A Study of Indoor Air Quality, Final Report," U.S. Environmental Protection Agency, Report No. EPA-650/4-74-042, Washington, D.C., 1974.
11. C.D. Hollowell et al., op. cit.
12. G.W. Traynor, M.G. Apte, J.R. Girman, and C.D. Hollowell, "Indoor Air Pollution from Domestic Combustion Appliances," in 1981 International Gas Research Conference Proceedings, Rockville, Maryland: Government Institutes, Inc.
13. G.W. Traynor, J.R. Allen, M.G. Apte, J.R. Girman, and C.D. Hollowell, "Pollutant Emissions from Portable Kerosene-Fired Space Heaters," Environmental Science and Technology 17, 369-371, 1983.
14. J.R. Girman, J.R. Allen, M.C. Apte, V.M. Martin, and G.W. Traynor, "Pollution Emission Rates from Unvented Gas-fired Heaters: a Laboratory Study," Lawrence Berkeley Laboratory report, LBL-14502, July 1982.
15. B.R. Hubble et al., "Experimental Measurements of Emissions from Residential Wood-burning Stoves," in Residential Solid Fuels: Environmental Impacts and Solutions, Beaverton, Oregon: Oregon Graduate Center.
16. D.J. Moschandreas, J. Zabransky, and H.E. Rector, "The Effects of Woodburning on the Indoor Residential Air Quality," Environment International 4, 463-468, 1980.
17. G.W. Traynor et al., "Indoor Air Pollution from Portable Kerosene-Fired Space Heaters, Wood-Burning Stoves, and Wood-Burning Furnaces," in Proceedings: Residential Wood and Coal Combustion, Pittsburgh: Air Pollution Control Association, 1982.

18. B.J. Ferris et al., "Effects of Sulfur Oxides and Respirable Particles on Human Health," Am. Rev. Respir. Dis. 120, 767-779, 1979.
19. M.D. Lebowitz and B. Burrows, "Respiratory Symptoms Related to Smoking Habits of Family Adults," Chest 69, 48-50, 1976.
20. J.D. Spengler et al., "Long Term Measurements of Respirable Sulfates and Particles Inside and Outside Homes," Atmospheric Environment 15, 23-30, 1981.
21. J.L. Repace and A.H. Lowrey, "Indoor Air Pollution, Tobacco Smoke, and Public Health," Science 28, 464-472, May 2, 1980.
22. J.D. Spengler et al., "Personal Exposure to Respirable Particles," Paper 80-61.5b, presented at the 73rd Annual Meeting of the Air Pollution Control Association, Montreal, Quebec, June 22-27, 1980.
23. U.S. Department of Health, Education, and Welfare, Public Health Service, "Smoking and Health, A Report of the Surgeon General," DHEW Publication No. PHS 79-50066. Washington, D.C.: U.S. Government Printing Office, 1979.

Section 5
HEALTH EFFECTS AND STANDARDS

IN THIS SECTION: What is known about health effects for selected pollutants; who devises air quality standards--ASHRAE, OSHA, EPA, state, foreign, and other guidelines; results of epidemiologic studies.

BASIC ISSUES

Health effects serve as the reference point for all concern about indoor air quality. Short-term exposure to certain indoor pollutants is known to cause serious physical harm, even death; however, the health effects of long-term exposures to low-level concentrations of indoor pollutants are not known. Although studies are underway to examine these questions, there are numerous difficulties in interpreting the results. A chief difficulty is finding study and control populations that are exposed to a given pollutant (e.g., NO₂) but not exposed to other pollutants that may produce similar effects. Both the ambiguity about health effects and the lack of clear mandates from federal agencies contribute to the lack of indoor air quality standards in the United States.

The most comprehensive standard to date, ASHRAE Standard 62-1981, "Ventilation for Acceptable Air Quality," is a compilation of foreign indoor air quality standards and guidelines, U.S. outdoor air quality standards, and other standards or guidelines developed for specific pollutants. Because such standards were sometimes developed for purposes other than regulating indoor air quality, and are based on assumptions that are not necessarily met in residential environments, they cannot be automatically extended to indoor residences, nor should they be considered absolute indicators of health hazards associated with contaminants. Because these guidelines and standards are the only official guidance we have, however, they are often referred to in studies of indoor air quality and, as such, will be discussed here.

In this country, acceptable levels of pollutants in outdoor air are set by the U.S. Environmental Protection Agency (EPA) under the Clean Air Act. The EPA mandate was to provide primary (protecting public health) and secondary (protecting public welfare) ambient (outdoor) air quality standards that protect the population "with an adequate margin of safety".¹ Presented in Table 5-1, these standards apply to sulfur oxides, particulate matter, carbon monoxide, ozone, nitrogen dioxide, and lead.

For industrial environments, toxic and hazardous substances have been regulated by the U.S. Occupational Safety and Health Administration (OSHA). In general, the practice has not been to eliminate all effects, such as unpleasant smells or mild irritation, but to limit exposure of workers to substances deemed harmful to health. Regulations are based on accumulated experience with worker health and on results of animal experiments, and refer to exposure to the injurious substance. The term "exposure", in the context of health effects, denotes the concentration of the substance as well as the duration of exposure to it. Because concentration commonly varies with time, exposure is expressed as a time-weighted average (TWA) concentration. Most OSHA regulations are given in TWA concentrations.

Industrial exposure to noxious substances is regulated on the assumption of a 40-hour work week of 8- or 10-hour days. Taking into account that public exposure to contaminants is not limited to 40 hours per week, ASHRAE 62-1981 recommends reducing the TWA by 1/5 for the general public, and then reducing it 1/2 further for safety (a total reduction of 1/10) on the assumption that the general population is more susceptible to toxins than is the typically adult population that works in industry. OSHA standards are given in Table 5-2.

HEALTH EFFECTS

Radon

Much of our knowledge about the human health effects of radon and its daughters is based on experience with underground uranium miners. These miners are generally exposed to radiation at concentrations much higher (100 times) than would ordinarily be experienced by occupants of residential buildings. The main health hazard from radon and its daughters is an increased risk of lung cancer because of the radiation dose to the lung tissue. Because the first four radon daughters have short half-lives (30 minutes or less), their inhalation and deposition in the lungs can expose the surrounding tissue to alpha particles before the body's lung-clearance mechanisms can remove them. Miners, exposed daily for many hours, do, in fact, develop lung cancer at a much higher rate than the general population. Individual health risk from radon daughters in residential buildings depends on the person's time-

Table 5-1

NATIONAL PRIMARY AMBIENT AIR QUALITY STANDARDS
AS SET BY THE U. S. ENVIRONMENTAL PROTECTION AGENCY

Contaminant	Long Term		Short Term		Reference
	Level	Averaging Time	Level	Averaging Time	
Sulfur Oxides measured as SO ₂	80 µg/m ³ (30 ppb)	1 year	365 µg/m ^{3a} (140 ppb)	24 h	40 CFR 50.4
Particulate matter	75 µg/m ^{3b}	1 year	260 µg/m ^{3a}	24 h	40 CFR 50.6
Carbon monoxide			10 mg/m ^{3a} (9 ppm)	8 h	40 CFR 50.8
			40 mg/m ^{3a} (35 ppm)	1 h	40 DFR 50.8
Ozone			235 µg/m ^{3c} (120 ppb)	1 h	40 CFR 50.9
Nitrogen dioxide	100 µg/m ³ (50 ppb)	1 year			40 CFR 50.11
Lead	1.5 µg/m ³	3 months ^e			40 CFR 50.12

Notes:

^aThis level may be exceeded only once per year.

^bGeometric mean.

^cThe standard is attained when the expected number of days per calendar year with maximum hourly average concentrations above 0.12 ppm (235 µg/m³) is equal to or less than 1, as determined by Appendix H to subchapter C, 40 CFR 50.

^dThe three-month period is a calendar quarter.

Table 5-2

OCCUPATIONAL SAFETY AND HEALTH STANDARDS AS SET BY THE
U. S. OCCUPATIONAL SAFETY AND HEALTH ADMINISTRATION

Contaminant	Level		Averaging Time	Reference
	(ppm)	(mg/m ³)		
Carbon dioxide	5000	9000	8 h time-weighted average	29 CFR 1910.1000
Carbon monoxide	50	55	8 h time-weighted average	29 CFR 1910.1000
Formaldehyde	3	3.6	8 h time-weighted average	29 CFR 1910.1000
Nitric oxide	25	30	8 h time-weighted average	29 CFR 1910.1000
Nitrogen dioxide	5	9	Ceiling value	29 CFR 1910.1000
Ozone	0.1	0.2	8 h time-weighted average	29 CFR 1910.1000
Sulfur dioxide	5	13	8 h time-weighted average	29 CFR 1910.1000
Inert or nuisance dust, respirable fraction		5	8 h time-weighted average	29 CFR 1910.1000
Asbestos		Less than two fibers longer than 5 μ per cm ³	8 h time-weighted average	29 CFR 1910.1001

integrated exposure to radon daughters.

Radon daughter concentrations are expressed in terms of total alpha energy emitted by the decay of the short-lived daughters. This potential alpha energy concentration (PAEC) is expressed in units of working levels (WL). (One working level has a value of 1.3×10^5 MeV/l, the potential alpha energy per unit volume that would be associated with air containing approximately 100 pCi/l of each of the shortlived daughters.) Radon daughter concentrations vary from 0.001 to 0.1 WL or more in U.S. homes. Because the incidence of radiation-induced cancer is related to cumulative exposure, the risk factor must be evaluated in terms of duration of exposure.

Again basing values on the exposure of uranium miners, total exposure is expressed in terms of the working level month (WLM), where exposure to 1 WL for 173 hours (the number of hours in one work month) yields 1 WLM. The annual exposure associated with a constant radon concentration of 1 pCi/l is approximately 0.25 WLM. (This result is based on using an equilibrium factor of 0.5, defined to be the ratio of the PAEC of actual daughters to the PAEC were each daughter to have the same activity concentration as that of the radon. Ventilation and plate-out of daughters to walls and other surfaces reduce the ratio of daughters to parents to a value less than one.)

The WLM is not a direct indication of dose, however. For one reason, the degree to which daughters are retained in the lungs depends on particle size. For another, breathing rates are lower for the general public than for workers. Considering breathing rates alone, the public would have to be exposed to twice the number of hours as in the normal working month of 173 hours to accumulate the same dose as a uranium miner (assuming the same WL exposure).

The cumulative exposures (in WLM) at which human and animal cancers are initiated are generally higher by an order of magnitude or more than those characteristic of the general indoor environment. Thus, in order to predict the health effects of decreased indoor ventilation and a corresponding increase in exposure to radon daughters, it is usually necessary to extrapolate beyond the range of exposures for which effects are known. The generally accepted method of predicting cancer induction rates at low dose rates is to assume a linear no-threshold dose-response function. Using the linear hypothesis and data from studies of uranium miners in the United States and Czechoslovakia, the number of lung cancers per unit of exposure to radon daughters ranges from 2.2 to 8×10^{-6} /year/WLM.² Thus our predictions of lung cancers specifically due to increased radon daughter concentrations will have an uncertainty factor of more than four, due merely to uncertainties in estimating actual doses and risk rates in miners. Applying this information to the general

Table 5-3

RADON STANDARDS

<u>Country</u>	<u>Average Annual Working Level (unless otherwise specified)</u>	<u>Action</u>	<u>Status</u>	<u>Reference</u>
INDOOR				
<u>United States</u>				
Sites contaminated by uranium processing	0.015	A cost-benefit analysis is required when level is only slightly above maximum	Interim and proposed cleanup standard for buildings contaminated by uranium processing sites	1
Phosphate land, Florida Existing housing	<0.02	Reduce to as low as reasonably achievable	Recommendation by EPA to Governor of Florida	2
	>0.02	Action indicated		
New housing	Normal indoor background			
<u>Canada</u>				
	>0.01	Investigate	Policy Statement by Atomic Energy Control Board	3
	>0.02	Primary action criterion		
	>0.15	Prompt action		
<u>Sweden</u>				
Max, existing buildings	200 Bq/m ^{3a}		Proposed Standard	4
Max, new buildings	70 Bq/m ^{3a}			
OCCUPATIONAL				
<u>United States (miners)</u>				
Instantaneous maximum	1 WL		Mine Safety and Health Administration Standard	5
Maximum cumulative dose	4 WLM/year ^b			

Notes:

^aAssuming an equilibrium factor of 0.5, these values are 0.027 WL and 0.009 WL respectively.

^bThe time period is a calendar year. The dose for any month is defined as the cumulative dose in WL-h divided by 173. Assuming 173 hours worked per month (i.e., 2076 hours per year) the average annual working level is 1/3 WL.

REFERENCES FOR TABLE 5-3

1. U. S. Environmental Protection Agency, "Interim Cleanup Standards for Inactive Uranium Processing Sites," Fed. Regist. 45:27366-68 (April 22, 1980).
Environmental Protection Agency, "Proposed Cleanup Standards for Inactive Uranium Processing Sites," Fed. Regist. 45:27370-75 (April 22, 1980).
2. U. S. Environmental Protection Agency, "Indoor Radiation Exposure Due to Radium-226 in Florida Phosphate Lands: Radiation Protection Recommendations and Request for Comment," Fed. Regist. 44:38664-70 (July 2, 1979).
3. Atomic Energy Control Board (of Canada) (AECB), "Criteria for Radioactive Clean-Up in Canada," AECB Information Bulletin 77-2 (April 7, 1977).
4. Department of Agriculture (of Sweden), Preliminary Proposal for Measures to Minimize Radiation Risk in Buildings, 1979, Sections 3.2.2 and 3.2.4.
5. U. S. Mine Safety and Health Administration (MSHA), "Regulations and Standards Applicable to Metal and Nonmetal Mining and Milling Operations," 30 CFR 57: 5-38 and 5-39, (July 1, 1979).

population increases the uncertainty.

In a small number of cases, however, radon concentrations indoors have been observed to be so high that individual exposure is comparable to the maximum exposure allowed for a miner. In these situations, the uncertainty regarding health effects is reduced because the linear no-threshold assumption is unnecessary.

Table 5-3 lists proposed and existing standards for radiation exposures from radon and its daughters. It should be noted that these standards generally came into being to deal with specific problems rather than explicitly to set overall guidelines.

Formaldehyde

Formaldehyde is a colorless, water-soluble gas having a pungent odor that can be detected by most people at levels well below 1 ppm. Relating specific health effects to specific concentrations of formaldehyde is difficult because people vary widely in their tolerances and subjective reactions. Furthermore, irritation and/or sensitization tolerance may develop after several hours of exposure and modify an individual's response. As with other toxins, the duration of the exposure is an important factor in the severity of any associated health effects. Health effects from acute exposure and long-term continuous exposure can be quite different, and knowledge of one cannot be used to predict the other.

Exposure to formaldehyde at concentrations of 0.05 - 0.5 ppm can cause burning of the eyes and irritation of the upper respiratory passages, depending on individual sensitivity and environmental conditions such as temperature and humidity. High concentrations (>few ppm) often produce coughing, constriction in the chest, and wheezing. Studies in rats and mice have shown that concentrations of formaldehyde of a few ppm for several months induce nasopharyngeal carcinoma.³ Table 5-4 summarizes the health effects of formaldehyde at various concentrations as reported by the National Research Council's Committee on Aldehydes.⁴

Table 5-5 summarizes various recommended and promulgated indoor air quality standards for formaldehyde. There is no outdoor standard for formaldehyde in the United States, but the American Industrial Hygiene Association recommends a guideline of 0.1 ppm. In The Netherlands, in 1978, the Ministry of Health recommended a maximum permissible indoor concentration of 0.1 ppm ($120 \mu\text{g}/\text{m}^3$), and Denmark, Sweden, and West Germany have considered similar values for their own standards.

Table 5-4

REPORTED HEALTH EFFECTS OF FORMALDEHYDE AT VARIOUS CONCENTRATIONS

Effects	Formaldehyde Concentration, (ppm)
None reported	0.0 - 0.05
Neurophysiologic effects	0.05 - 1.5
Odor threshold	0.05 - 1.0
Eye irritation	0.01 - 2.0 ^a
Upper airway irritation	0.10 - 25.0
Lower airway and pulmonary effects	5.0 - 30.0
Pulmonary edema, inflammation, pneumonia	50.0 - 100.0
Death	100+

Source: National Research Council.

^aThe low concentration (0.01 ppm) was observed in the presence of other pollutants that may have been acting synergistically.

Table 5-5

FORMALDEHYDE STANDARDS

	Level (0.1 ppm \approx 120 $\mu\text{g}/\text{m}^3$)	Status	Reference
AMBIENT AIR			
<u>United States</u>	0.01 ppm max	Recommended by AIHA	1
INDOOR AIR			
<u>United States</u>			
California	0.05 ppm	Proposed	2
Minnesota	0.5 ppm		3
Wisconsin	0.4 ppm		4
<u>Denmark</u>	0.12 ppm max	Recommended	5
<u>Netherlands</u>	0.1 ppm max	Recommended by Ministers of Housing and Health	6
<u>Sweden</u>	0.1 ppm max, new buildings 0.4 ppm min, old buildings ^a 0.7 ppm max, old buildings ^a	Proposed by the National Board of Health and Welfare	7
<u>Federal Republic of Germany</u>	0.1 ppm max	Recommended by the Ministry of Health	8
OCCUPATIONAL AIR			
<u>United States</u>	3 ppm, 8-h time-weighted average	Promulgated by OSHA	9
	5 ppm, ceiling	Promulgated by OSHA	9
	2 ppm, threshold limit value	Recommended by ACGIH	10
	1 ppm, 30-min max	Recommended by NIOSH	11

^a0.4 to 0.7 ppm is a border area. Levels higher than 0.7 ppm do not meet the standard. Levels lower than 0.4 ppm meet the standard. Levels within the border area do not meet the standard if the dwellers complain. In recently built houses, 0.7 ppm should be acceptable during the first six months.

REFERENCES FOR TABLE 5-5

1. American Industrial Hygiene Association, "Community Air Quality Guides, Aldehydes," Am. Ind. Hyg. Assoc. J. 29:505 (1968).
2. State of California, Assembly Bill No. 2586, as amended in Assembly, April 16, 1980.
3. Minnesota Stat. Sec. 114.495, 1980.
4. Wisconsin Administrative Code, Sec. 14.01 et seq., 1980.
5. I. Andersen, "Formaldehyde in the Indoor Environment--Health Implications and Setting of Standards," paper presented at the Indoor Climate Symposium, Copenhagen, Denmark, August 30-September 2, 1978.
6. R. Baars, "The Formal Aspects of the Formaldehyde Problem in the Netherlands," paper presented at the International Indoor Climate Symposium," Copenhagen, Denmark, August 30-September 2, 1978.
7. H. Wahren, "Formaldehyde Indoor Air Standards in Sweden," paper presented at the CPSC Technical Workshop on Formaldehyde, Washington, D.C., April 9-11, 1980.
8. D. Bernd Seifert, Institut für Wasser-, Boden- und Lufthygiene des Bundesgesundheitsamtes, Berlin, Germany, private communication, May 1978.
9. U. S. Occupational Safety and Health Administration, Occupational Safety and Health Standards, Hazardous Materials, 29 CFR 1910.1000, July 1, 1979.
10. "TLVs--Threshold Limit Values for Chemical Substances and Physical Agents in the Workroom Environment with Intended Changes for 1977," American Conference of Governmental Industrial Hygienists, P.O. Box 1937, Cincinnati, OH 45201 (1977).
11. National Institute for Occupational Safety and Health, Criteria for a Recommended Standard . . . Occupational Exposure to Formaldehyde, NIOSH Publication No. 77-126 (December 1976).

Combustion Products

Carbon Monoxide. Carbon monoxide is produced at the greatest rate when combustion is incomplete. For example, a poorly-tuned gas stove can give off CO at thirty or more times the rate of its well-tuned counterpart. Carbon monoxide enters the body through the respiratory system and reacts primarily with the hemoglobin of the circulating blood. Because the affinity of hemoglobin for CO is more than 200 times that of oxygen, the absorption of CO reduces the oxygen-carrying capacity of blood. Experimental exposure of nonsmokers to 50 ppm for 90 minutes revealed that their discrimination of time intervals was impaired.⁵ This exposure is likely to produce a carboxyhemoglobin (COHb) level in the blood of about 2.5%, corresponding to that associated with continuous exposure to 10-15 ppm for eight or more hours. EPA and OSHA standards for CO are given in Tables 5-1 and 5-2, respectively.

Carbon Dioxide. The present federal limit for carbon dioxide exposure in the workplace is 5000 ppm of air, by volume, for a time-weighted eight-hour daily average. Much of the research on physiological effects of CO₂ exposure has been done to establish safe limits for submarine crews and astronauts.

The National Aeronautics and Space Administration limit for a six-month exposure in spacecraft is 10,000 ppm. The Bioastronautics Data Book states that "for prolonged exposures of 40 days, concentrations of CO₂ in air less than 5000 ppm cause no known biochemical or other effect. Concentrations between 5,000 and 30,000 ppm cause adaptive biochemical changes which may be considered a mild physiological strain; and concentrations above 30,000 ppm cause pathological changes in basic physiological functions."⁶

Schafer, in his review of submarine research, states that "at a 15,000 ppm exposure, performance and physiologic functioning were not adversely affected, although acid-base and electrolyte adaptation occurred as a result of continuous exposure. At levels above 30,000 ppm CO₂, deterioration in performance may be expected, as may alterations in basic physiologic functions, such as blood pressure, pulse rate, and metabolism."⁷

Some Russian laboratories report respiratory effects resulting from CO₂ levels as low as 1,000 ppm; in specific cases, the amplitude of the respiratory movement was reportedly reduced and peripheral blood flow increased at this low concentration.⁸

Nitrogen Oxides. Nitric oxide (NO) and nitrogen dioxide (NO₂) are both formed as products of combustion. Of the two, nitrogen dioxide is the more reactive, and poses the greater health hazard. Exposure to concentrations of 5 ppm can cause respiratory distress; concentrations of about 50 ppm can cause chronic lung disease; and exposures greater than 150 ppm can cause death. In controlled laboratory studies, concentrations in the range of 0.10 to 0.50 ppm were associated with respiratory distress in individuals having chronic respiratory ailments. The National Ambient Air Quality Standard (NAAQS) for outdoor exposure to NO₂ is 0.05 ppm.

Epidemiological studies in large groups of persons exposed to long-term, low-level concentrations of nitrogen dioxide in their homes are inconclusive. Two studies, both of primary school children in England, suggest a relationship between respiratory illness and the NO₂ exposure from gas-stove cooking.^{9,10} On the other hand, according to a similar study by Keller et al., neither an increase in respiratory disease nor a decrease in pulmonary function was associated with the use of gas for cooking.¹¹ Another ongoing study seems to indicate that children raised in homes with gas stoves have a greater history of respiratory illness before age 2 than do children raised in homes with electric stoves.¹²

Particulate Matter

Individuals inhale a wide variety of particulate matter into their respiratory systems. Where particles are deposited and how long they are retained depends on their size, chemical composition, and density. Particles larger than 15 microns in diameter are filtered out by the nose and dislodged within several days. Smaller particles settle on the tissues of the upper respiratory tract, with the smallest particles (under 2.5 microns) penetrating the alveoli, the small air sacs in the lungs. Particles deposited in the lungs can remain there for months, and can cause adverse health effects for long periods of time.

Particulate matter may exert a toxic effect because: (1) it is intrinsically toxic due to its chemical or physical characteristics (e.g., lead and asbestos) or (2) it acts as a carrier of an adsorbed toxic substance (e.g., radon daughters can be attached to particles emitted in cigarette smoke).

Asbestos fibers. Widespread use of asbestos in building materials ranging from pipe insulation, floor and ceiling tiles, and spackling compounds presents a potential health problem. Most of the asbestos in use is immobilized in strong binding material, but if the material is cut or broken, asbestos fibers can be released. Occupational exposures to asbestos fibers have been linked to lung cancer in workers

and in families of workers who come into contact with the fibers through contaminated clothing. Because few measurements of asbestos fibers in the air are available, risks to the public in houses, schools, and office buildings are unknown. The possibility of synergistic effects with other pollutants, cigarette smoke in particular, poses public health questions.

Carbon particles, such as those emitted in combustion processes, are efficient adsorbers of many organic and inorganic compounds and can carry toxic gases such as SO₂ into the lungs. This can have a potentiating effect on the human body; that is, particles that contain an attached toxic substance can increase a person's physiological response to that substance to a level above what it would be otherwise.

Another class of particles are the biological substances: infectious agents, allergens, and toxins, as well as fungal spores (mold), pollen, and house dust. These particles can act as disease-transmitting agents when released from the respiratory tract, where they can be airborne for many minutes until they attach to another particle and settle. Viruses and pathogenic bacteria may be components of larger particles.

Epidemiological studies have associated the presence of suspended particles with health effects of varying severity. Respiratory illness, especially chronic diseases such as bronchitis and emphysema, show the strongest positive association with levels of particulate matter. Adverse health effects have been observed for an annual mean level of particles as low as 80 µg/m³. However, these particulate levels are usually associated with high levels of SO₂, and the effects of the two have not been separated.

ORGANICS

An exceedingly large number of organic substances (other than aldehydes) is present indoors. At present little is known about possible adverse or synergistic effects on human health resulting from long-term, low-level exposure to most of these chemicals. Of special concern here are carcinogens, chemicals that promote or enhance the development of cancer--for example, solvents, polymer components, pesticides, and other organic chemicals.

Organic solvents and their vapors are a common part of the indoor environment. Aliphatic hydrocarbons such as propane, butane, and isobutane are used primarily as propellants for aerosol products and have no known chronic effects on health. Higher-molecular-weight aliphatic hydrocarbons such as hexane, heptane, and octane are used as solvents in many consumer products, including glues, varnishes, paints,

and inks. Exposure to n-hexane has been linked to degeneration of the nervous system. Aromatic hydrocarbons are also used extensively as solvents. Toluene causes symptoms of fatigue, weakness, and confusion in humans exposed to 200-300 ppm for 8 hours. Chronic exposure to another aromatic hydrocarbon, benzene, leads to damage of blood-forming tissue, and may be related to leukemia. Other solvents such as halogenated hydrocarbons, alcohols, ketones, ethers, and esters are all associated with a variety of health effects. For more information, the National Academy of Sciences' publication, Indoor Pollutants, contains a detailed description of these chemicals and their effects.

Polymer components are used in building materials, furniture, clothing, and numerous other consumer products. These polymers contain unreacted monomers and other chemicals such as plasticizers, stabilizers, fillers, colorants, and antistatic agents. Recently, attention has been focused on the potential release of these chemicals into indoor air. Monomers such as vinyl chloride are both strong irritants and carcinogens. The toxicity data for plasticizers, as yet incomplete, generally find them non-toxic except at very high doses. In animal studies, however, some plasticizers have been shown to be carcinogenic. A number of other chemicals found in plastics may also be pollutants of indoor air.

Pesticides identified by an EPA residential indoor-monitoring study included chlordane, ronnel, dursban, DDVP, and malathion. The general effects of these chemicals are nausea, vomiting, headaches, tremors, abdominal pain, and mild chronic jerking. Chlordane also causes cancer in mice.

Other organic chemicals include benzo-a-pyrene, already discussed as a combustion by-product, and pentachlorophenol (PCP), a common wood preservative. The widespread use of pentachlorophenol and its longevity raise concern about human exposures. Residents of log homes that were treated with pentachlorophenol showed blood levels of 0.39 ppm, versus 0.04 ppm for the general population.¹³ PCP causes lung, liver, and kidney damage, and is currently being tested as a possible carcinogen.

REFERENCES

1. U.S. Environmental Protection Agency, National Primary and Secondary Ambient Air Quality Standards, Code of Federal Regulations, Title 40, Part 50 (40 CFR 50.1), Washington, D.C.: U.S. Government Printing Office, 1981.
2. National Academy of Sciences, Indoor Pollutants, Washington, D.C.: National Academy Press, 1981.
3. Ibid.
4. National Research Council, Committee on Aldehydes, "Formaldehyde and Other Al-

dehydes," Washington D.C.: National Academy Press, 1981.

5. National Research Council, Committee on Medical and Biological Effects of Environmental Pollutants, "Carbon Monoxide," National Academy of Sciences Press, Washington, D.C., 1977.
6. National Aeronautics and Space Administration, Bioastronautics Data Book, NASA - SP 3006, Washington, D.C., 1973.
7. K.E. Schaefer, "A Concept of Triple Tolerance Limits Based on Chronic CO₂ Toxicity Studies," Aerospace Medicine 32, 197-204, 1961.
8. M.S. Goromosov, "The Physiological Basis of Health Standards for Dwellings," World Health Organization, PHS 33, Geneva, 1968.
9. C. Florey et al., "The Relationship between Respiratory Illness in Primary School Children and the Use of Gas for Cooking," Int. J. Epidemiol. 8,: 347-353, 1979.
10. R.J. Melia et al., "The Relationship between Respiratory Illness in Primary School Children and the Use of Gas for Cooking," Int. J. Epidemiol. 8,: 333-338, 1979.
11. M.D. Keller et al., "Respiratory Illness in Households Using Gas and Electricity in Cooking," Environ. Res. 19, 495-503, 1979.
12. F.E. Speizer et al., "Respiratory Disease Rates and Pulmonary Function in Children Associated with NO₂ Exposure," Am. Rev. Respir. Dis. 121, 3-10, 1980.
13. Interagency Research Group on Indoor Air Quality, Workshop on Indoor Air Quality Research Needs, United States Department of Energy and Environmental Protection Agency, April 1981.

Section 6
MONITORING AND MODELING INDOOR AIR QUALITY

IN THIS SECTION: Descriptions of techniques and devices for monitoring air quality; fixed-location samplers, personal monitors; modeling.

BASIC ISSUES

In order to know when and where potentially harmful pollutants exist we need to have some method for determining their concentrations. Ideally, such a method should be accurate, rapid, consistent, inexpensive, and simple enough for a nontechnical person to use. Two approaches are used to determine levels of air pollutants: 1) direct measurement, and 2) numerical modeling.

Techniques and instruments developed for monitoring outdoor air or industrial environments have served as the basis for current practices, although several problems emerged when adaptations were made for indoor use. Passive samplers, light in weight, reliable, inexpensive, and unobtrusive, are an example of an improvement over previous instrumentation. These devices allow large-scale measurements to be made of individual and population exposures to air pollutants. Advances in electronics have also contributed to improvements made in the real-time instrumentation that facilitates pollutant characterization.

Numerical models have been used to estimate the extent of indoor air pollution. Mass-balance equations, for example, are used to estimate concentrations of indoor pollutants as fractions of outdoor concentrations and to estimate the effects of important variables such as infiltration rate, indoor source strength, pollutant decay rate, and mixing factors. Several models have been developed, but only in a few cases have findings been validated against data obtained from direct measurements.

Human responses to a pollutant have usually been the impetus for a subsequent investigation and measurement. Evaluation of people's responses to contaminants as well as knowledge of individual patterns of mobility and activity are essential in estimating the total exposure of humans to pollutants.

The choice of monitoring technique depends on the type of information desired and the resources and labor available. A description of these techniques with their advantages and disadvantages is presented in the following sections.

MEASUREMENT TECHNIQUES

Methods of measuring contaminant concentrations can be divided into several categories. Broadly speaking, there are techniques that collect continuous data and others that collect average results integrated over the measurement period. Within each of these categories are instruments that measure at a fixed location and those that are small enough to be carried by the user. Fixed-location sampling and monitoring may involve grab sampling, integrated sampling, or continuous monitoring. Personal monitors can be passive devices (i.e., not requiring sampling pumps) for sampling gases, or pumped devices for both gases and particulate materials. Tables 6-1 through 6-5 (located at the end of Section 6) list commercially available monitors for select pollutants.

Grab Sampling

Grab sampling is a technique for collecting an air sample in a plastic bottle, glass tube filled with adsorbent, stainless-steel container, bag of aluminum polyester, PVC film, or fluoroplastic film.¹ The specific grab-sampling method used varies depending on the target pollutant. Grab samples of air can be analyzed immediately to give a gross estimate of concentration, or returned to the laboratory for more accurate analysis. This technique is most usefully employed when the laboratory equipment required for analysis is difficult to move, when large numbers of samples are required, and when inexpensive labor is available. Grab-sampling analysis provides a short-term average (or possibly instantaneous) pollutant concentration of the air sampled, but samples must be taken frequently to ascertain the variability of the pollutant over time.

This technique has been used to estimate concentrations of carbon monoxide, tracer gases, organic compounds, and radon. Radon concentrations can be measured by pumping a known volume of air into a one-liter flask. The time at which the sample is taken must be recorded, and, because of the decay properties of the radon gas,

analysis must be performed within a few days. If necessary, the sample can be concentrated with a cryogenic trap or transferred directly into a zinc-sulfide-coated scintillation flask for alpha counting. The containers are durable and can be mailed, along with manual pumps, to field sites.

Grab sampling for radon progeny requires that the sample be analyzed immediately after collection because of the short half-lives of the progeny. Samples are obtained by pumping a known volume of air through a filter, removing the filter from the pump assembly, and measuring the alpha activity of the progeny. For this purpose, then, analytic equipment must be at the site for immediate use.

As suggested, its low cost and minimal labor requirements make grab sampling suitable for large-scale survey work. The problems associated with this technique, however, need to be borne in mind: No information other than an instantaneous concentration can be obtained, and this value can be drastically affected by something as simple as the opening of a door or window. Sampled volumes are relatively small, and the laboratory measurement technique must be sensitive enough to determine ambient concentrations directly. Inward and outward diffusion of various gases has been observed for many materials used in collection bags, and leaks in the containers and connectors are common. Particular attention must be given to degradation, adsorption, contamination, transformation, and the possible formation of artifact pollutants, that is, pollutants formed by the sampling or measurement process. Quality control is difficult to maintain, but must be established before this technique can be used with confidence.

Integrated Sampling

When pollutants are present in such small quantities that they are undetectable by grab sampling, integrated sampling, in which a known sampling rate is maintained over some fixed period of time, is commonly used. The collection period may be as short as minutes or as long as weeks or months. The results from the analysis of integrated samples are expressed as average concentrations over the sampling period. A variety of particles, gases, and vapors are sampled by this technique.

Integrated sampling of particles can be accomplished by means of dichotomous air samplers capable of discriminating larger from smaller particles. The sophistication of the samplers ranges from manually operated hand-held units to fully automated units that can run for weeks unattended. The samplers must be placed directly at the sampling site to avoid the particle losses that occur when air is drawn through sampling lines.

To obtain long-term concentrations of radon and radon daughters in buildings, integrated sampling techniques are often used. Passive devices that use sensitive thermoluminescent dosimeter chips or track-etch techniques can record alpha decay over periods of weeks or months and, from these data, can determine average radon concentrations.² Radon progeny concentrations can also be measured by passing a known volume of air through a filter paper (typically for five minutes) and then measuring total alpha activity on the filter with a scintillation counter, or measuring alpha energies with a solid-state detector.

Integrated samples of gaseous substances, such as ammonia and formaldehyde, can be collected by liquid-gas washers and bubblers (Figure 6-1). Air sampling with bubblers requires that the total volume of the air sample be accurately known. A sample volume can be measured directly with dry- or wet-test meters, or by measuring or controlling the sampling rate and time.

Integrated sampling techniques have several advantages: They are often less expensive and require fewer personnel than continuous monitors; they can be used to measure concentrations that are too low to be measured directly; samples can sometimes be analyzed later at a more convenient time or place; and average concentrations over long periods of time can be easily obtained. Their disadvantages are that short-term temporal information is lost; transporting the sample to the point of analysis may require special handling; special environmental conditions, or rapid delivery to avoid deterioration; and quality control may be difficult to implement.

Continuous Monitoring

Continuous monitoring allows sampling and measuring of the real-time concentration of pollutants, often useful for determining the actual pollutant concentrations to which occupants are exposed, or for modeling indoor air pollution.

Continuous monitors are commercially available for all the gaseous pollutants designated "criteria" pollutants by the EPA--carbon monoxide, sulfur dioxide, nitrogen dioxide, and ozone. The EPA has specified performance criteria for the instruments used to measure each of these pollutants, and all analyzers that meet these specifications in performance tests are designated "EPA-approved."

Two positive features of continuous monitoring are that, in addition to being able to calculate average concentrations over any time period, peak short-term concentrations, which may have important health effects, can also be determined. Furthermore, variations in concentration as a function of time can be correlated with source

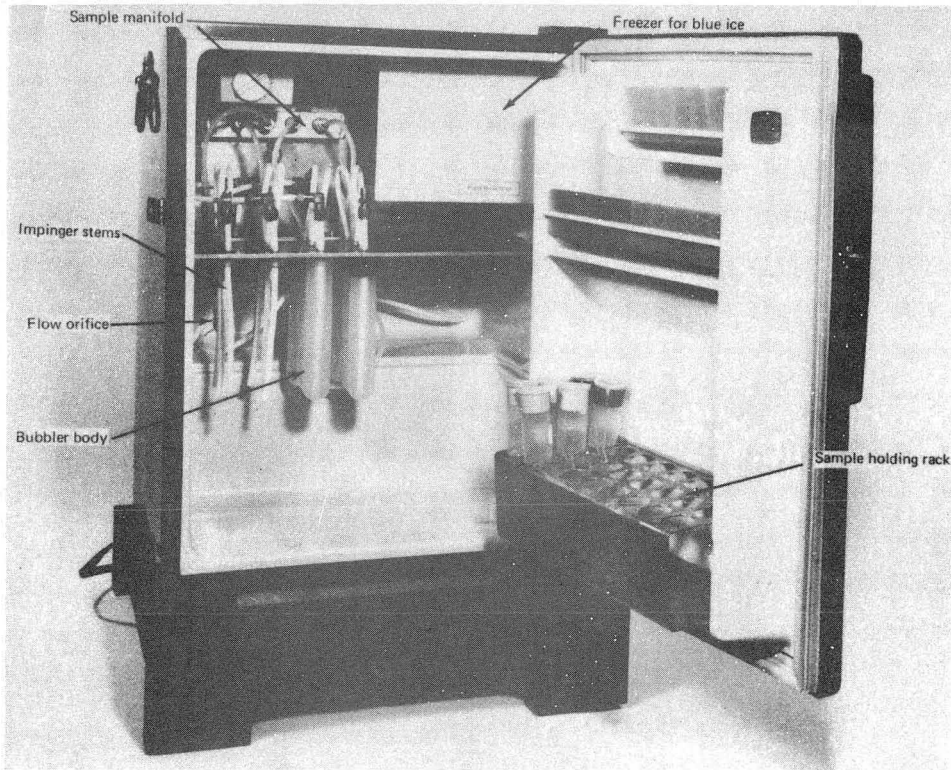

XBB 805-6058A

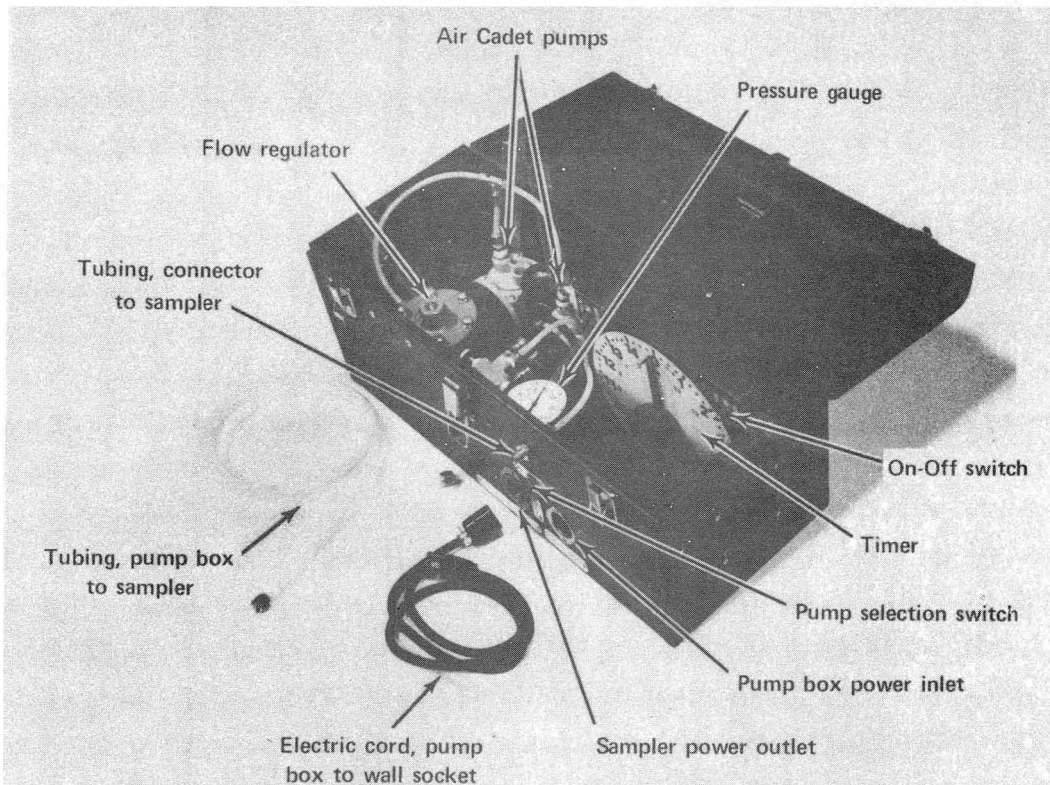

XBB 817-6976A

**Figure 6-1. Above: refrigerated formaldehyde sampler
Below: formaldehyde sampler pump box**

generation, infiltration/ventilation rates, and other relevant parameters.

Although continuous monitoring has numerous benefits, it also has disadvantages: Such systems are expensive and require frequent calibration and routine maintenance. In addition, they have their own power and ambient-temperature requirements and can create safety, heat, and noise problems points. For these reasons, continuous monitoring systems are often designed so that equipment for continuous analysis and recording are at a single remote site, often a mobile laboratory (Figure 6-2).



Figure 6-2. Mobile indoor air quality laboratory

CBB 814-3658

Such a laboratory usually contains facilities for calibration and maintenance, and may also provide electric power and suitable environmental conditions for the equipment.

Because of the complexity of the equipment, continuous monitoring requires highly-trained field personnel, rigorous quality-control (calibration) procedures, and independent performance audits of routine monitoring and data-handling operations. Securing electric power and a suitable location equipped with sampling lines and cables for the laboratory can require long-term planning and entail considerable expense. For large-scale surveys, integrated sampling and grab-sampling techniques are often more appropriate, and less costly, than continuous monitoring.

Personal Monitors

In addition to other variables, individual mobility patterns and activities affect a person's exposures to air pollutants. To evaluate health effects for individuals or for populations, it is necessary to know the detailed pattern of individual or population exposures.

During the last two decades, a wide variety of miniaturized air samplers that can be worn by individuals have become available. Initially, these devices contained battery-powered sampling pumps, and were called "active" samplers. Although widely used, these samplers were often heavier and larger than desirable for carrying around as a personal monitor. More recently, a variety of diffusion- and permeation-controlled samplers have become available. These "passive" devices are applicable solely to gas and vapor sampling. Particulate matter is collected by the same principles used for large-scale collection: filtration, impaction, and liquid impingement.

Active Samplers

A considerable variety of sampling systems using pumps to move the air have been developed recently, including impinger systems and solid absorbers for gases, and impingers, filters, and impactors for solid particles. (The relatively low power supplied by the battery available for driving the air-sampling pump usually limits particle collection to filtration.) A promising development in personal monitors--one yet to be validated--involves a pump that is worn in a light harness and driven by the wearer's chest expansion and contraction while breathing. Both gases and particulates can be sampled with this device, and once calibrated with the wearer's breathing rate, doses of the measured pollutants can be calculated.

Passive Samplers

Passive personal monitors use the kinetic energy of gas molecules and the variation in concentration of the pollutant gas in an enclosed space to collect a sample of pollution from the air for subsequent analysis (Figure 6-3).

Diffusion Samplers. Personal monitors based on diffusion are used to detect a variety of substances, including sulfur dioxide, nitrogen dioxide, nitric oxide, many organics, carbon monoxide and, recently, formaldehyde. In the formaldehyde sampler, a glass-fiber filter located at the closed end of the tube is impregnated

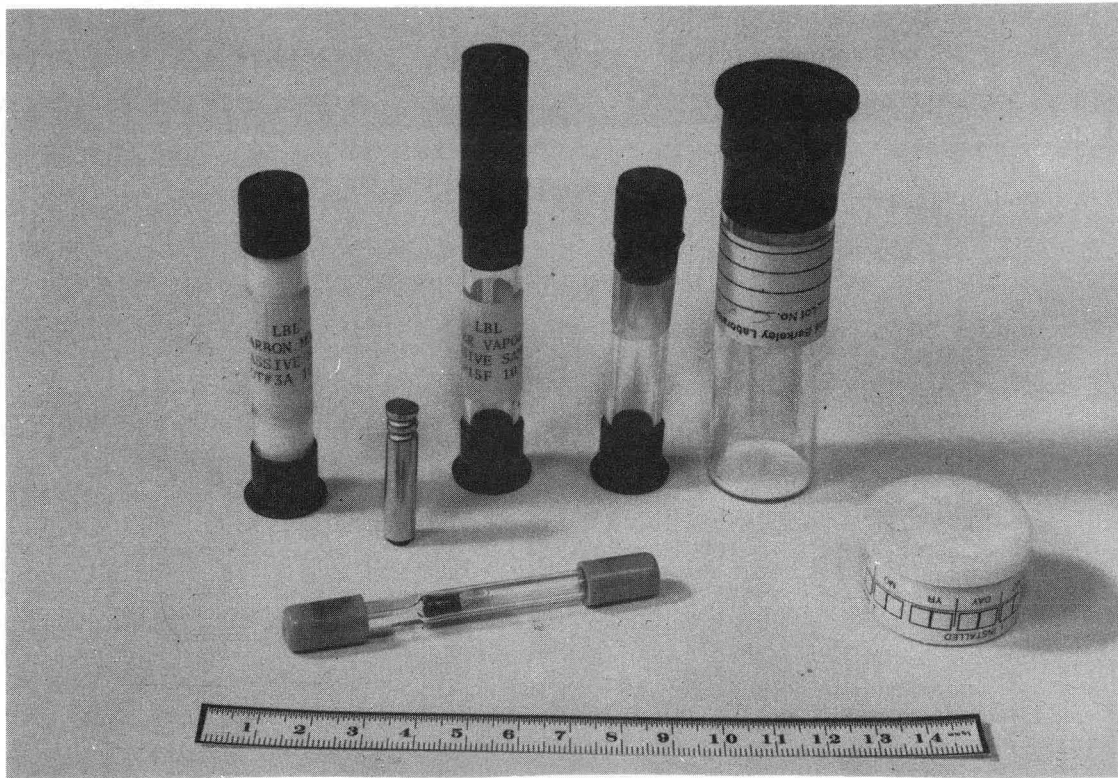

CBB 834-3491

Figure 6-3. Passive samplers--left to right (back): Carbon monoxide, infiltration source, water vapor, nitrogen dioxide, formaldehyde; (front): infiltration (sampler), radon.

with sodium bisulfate that reacts with formaldehyde and removes it from the air. Because of this reaction at the tube's closed end, the concentration of formaldehyde in the tube ranges from the value present in the room air at the tube's open end to zero at the closed end. This concentration gradient, rather than a pump, drives the gas by diffusion to the collection site at the tube's closed end. A diffusion-tube sampler is inexpensive (typical bulk costs are \$15 each including analysis), is lightweight and quiet (and therefore unobtrusive), and is available for sampling many common indoor air contaminants. The disadvantages are that only long-term average values can be collected and, typically, samples must be analyzed at a laboratory and not on-site.

Because of their low cost and ease of use, passive samplers should be considered for initial screening of indoor air quality in a building--as, for instance, when occupants register a complaint, or when large numbers of buildings must be screened to determine the range of pollutant concentrations in the entire building stock of a particular region.

A recently completed study by Science Applications, Inc. (SAI) for the California Air Resources Board demonstrates the flexibility afforded by passive samplers. As part of a survey to quantify formaldehyde sources in the state of California, SAI measured one-week average concentrations of formaldehyde in 64 houses in the state. The houses were randomly selected from all regions of the state. Contacts with the homeowners were made by telephone, and the passive samplers with instructions for use were mailed to homeowners. Finally, all samplers were returned to SAI by mail for analysis. Although the lack of direct control over sampler placement is cause for concern, the possibility of screening houses without direct visits by field personnel reduces costs and therefore allows a wide-scale survey of the building stock.

Another type of diffusion sampler, the permeation sampler, is available commercially in many styles. All use membranes (with many tubes, not just one) that are fabricated and calibrated to control the rate of permeation of the pollutant to the collector. More than 80 compounds can be determined by this method, including sulfur dioxide and nitrogen dioxide.

MODELING INDOOR AIR QUALITY

Indoor air quality models are mathematical procedures that yield predictions of pollutant concentrations in specific situations. The models are valuable for planning measurements, projecting changes in air quality when some aspect of the indoor space is changed, and generalizing the results of laboratory measurements to other situations.

For example, air quality models are used to calculate the concentration of nitrogen dioxides that may be expected in residences that operate unvented kerosene space heaters. For inputs, the model relies on laboratory measurements of the heater's emission rate and assumptions concerning the ventilation rate in the house.

Most models are derived from a mass-balance hypothesis, i.e., the rate of change of pollutant mass within a space is the difference between the pollutant's input rate (generation rate inside the space plus its entry rate from the outside) and the pollutant's removal rate (flow to the outside plus its removal by reactions within the volume). An example of such a model is reported in the work of Moschandreas, Zabransky, and Pelton.³ Similar to several other representations of the problem, their model takes the form:

$$V \frac{dC_{in}}{dt} = V A C_{out} + S - V A C_{in} - V D C_{in}$$

where:

- C_{in} = indoor pollutant concentration [mass/volume],
 C_{out} = outdoor pollutant concentration [mass/volume],
 V = volume of structure [volume],
 S = rate of indoor pollutant emission [mass/time],
 D = decay rate within structure [time⁻¹], and
 A = ventilation rate, [time⁻¹].

An important assumption for the validity of this equation is that the space be a single well-mixed zone. The model has been found to represent actual conditions quite well in buildings where this assumption is met and where all the parameters required by the model are known. Typically, residences that have central forced-air heating systems meet this criterion residences having other forms of heating often meet the criterion also, as long as interior doors remain open.

The steady-state solution of the model equation takes the form:

$$C_{in} = \frac{A C_{out} + \frac{S}{V}}{A + D}$$

The solution explicitly demonstrates the information needed to properly interpret measurements of pollutant concentrations. Many early measurements of indoor air quality included only pollutant concentration measurements. The steady-state solution shows that even if the outdoor concentration is negligible ($C_{out} \approx 0$) and the pollutant is nonreactive ($D \approx 0$), it is not possible to predict the future behavior of the pollutant concentration in the space, even in a qualitative way, without knowing either the source emission rate, S , or the ventilation rate, A .

As measurement accuracy improves, the limitations in single-zone models becomes apparent. Multizone models resemble the single-zone mass-balance equation but include a separate mass-balance equation for each zone. The solution of these sets of equations is complicated by the presence of terms that describe pollutant transport among the zones. A multizone model is required, for example, to describe the concentration of pollutants in a single room of a house (the first zone) when an unvented combustion space heater is used to heat just the single room and the remainder of the house (the second zone) is separated from the first zone by closed doors.

To summarize, the purpose of an indoor air quality model is to describe the relationships among the important parameters that determine the concentrations of indoor pollutants. Single-zone models are often appropriate, particularly in residential buildings. Many buildings, however, require using multizone models.

REFERENCES

1. F.J. Schuette, "Plastic Bags for Collection of Gas Samples," Atmospheric Environment 1, 515-519, 1967.
2. National Academy of Sciences, Indoor Pollutants, Washington, D.C.: National Academy Press, 1981.
3. D.J. Moschandreas et al., "Comparison of Indoor and Outdoor Air Quality," Electric Power Research Institute report, EA-1733, Palo Alto, California: EPRI, 1981.

Table 6-1

NITROGEN DIOXIDE PASSIVE INTEGRATING MONITORS

<u>Trade Name/Model</u>	PS-10 Passive Sampler	PRO-TEK	NO ₂ Badge (Toyo Roshi Co.)
<u>Manufacturer Address</u>	DACO Products 12 South Mountain Ave. Montclair, NJ 07042	DuPont Fabric and Finish 4300 Brandywind Blvd. Wilmington, DE 19898	Microfiltration Systems 6800 Sierra Ct. Dublin, CA 94568
<u>Contact</u>	Pat	Dr. Bert Kring	
<u>Telephone</u>	(201) 744-2453	(215) 444-4188	(415) 828-6010
<u>Collection Mechanism</u>	Diffusion/absorption	Diffusion/absorption	Diffusion/absorption on treated filter
<u>Sampling Time</u>		As long as desired	
<u>Range</u>	0-5 ppm-hr	1.5 - 200 ppm-hr	0.07 ppm-hr
<u>Sensitivity</u>	1 ppm-hr		66 ppb-hr
<u>Accuracy</u>		±25% or less	±20%
<u>Cost</u>	\$20/10 (tubes and filters)	\$275/10	\$18.65/ea.
<u>Analysis Requirements</u>	Spectrophotometric	Spectrophotometric: Measured by a small dedicated colormeter.	Spectrophotometric
<u>Analysis Cost</u>	\$12 each	\$15 each	not included

Table 6-2

FORMALDEHYDE PASSIVE INTEGRATING MONITORS

<u>Trade Name/Model</u>	AQR Formaldehyde Badge	PRO-TEK	3M Formaldehyde Monitor 3750
<u>Manufacturer</u>	Air Quality Research	DuPont Fabric & Finish Dept. Applied Technology Div.	3M Occup. Health & Safety Products Division
<u>Address</u>	2800 7th Street Berkeley, CA 94610	Barley Mill Plaza, Marshall Mill Bldg.	220-7W 3M Center St. Paul, MN 55144
<u>Contact</u>	Bob Miksch/S. Rappaport	Wilmington, DE 19898 Dr. Bert Kring	Jim Krikstad
<u>Telephone</u>	(415) 644-2097	(215) 444-4188	(800) 328-1300
<u>Collection Mechanism</u>	Diffusion/absorption	Diffusion/absorption	Diffusion
<u>Sampling Time</u>	4-8 days	As long as desired	8-48 hr
<u>Range</u>		2-54 ppm-hr	8-180 ppm-hr
<u>Sensitivity</u>	0.25 ppm-168 hr sample	0.2 ppm-8 hr sample	0.8 ppm-174 hr sample
<u>Accuracy</u>	±25%	<25%	±5%
<u>Cost</u>	\$18/2	\$235/10	\$35 each, \$150/5
<u>Analysis Requirements</u>	Spectrophotometric: Analysis can be done by mfg. or local lab with spectrometer.	Spectrophotometric: Can be done by local lab with spectrometer.	Spectrophotometric
<u>Analysis Cost</u>	\$30/2	\$20-35 (at local lab)	\$20-35 (at local lab)

Table 6-3

RESPIRABLE SUSPENDED PARTICLES ACTIVE INTEGRATING MONITORS

<u>Trade Name/Model</u>	RSP Sampler	Dichotomous Sampler Series 241
<u>Manufacturer</u>	W. S. Fleming & Assoc.	Anderson Samplers
<u>Address</u>	47 Quail Ct., Suite 311 Walnut Creek, CA 94596	4215 Wendell Drive Atlanta, Georgia 30336
<u>Contact</u>	Greg Traynor	
<u>Telephone</u>	(415) 947-0321	(800) 241-6898
<u>Collection Mechanism</u>	Air filtration	Size selective inlet followed by virtual impactor
<u>Sampling Time</u>	Variable: hours-weeks	24 hours
<u>Range</u>	0.2-5.0 l/min.	16.7 l/min.
<u>Sensitivity</u>	N/A	N/A
<u>Accuracy</u>	2%-week	±5% at 16.7 l/min.
<u>Power Requirements</u>	AC (DC battery option)	110/115V AC
<u>Cost</u>	\$1500 each	\$5100 each
<u>Analysis Requirements</u>	Gravimetric analysis by microbalance.	Gravimetric analysis
<u>Analysis Cost</u>	\$10/filter	Teflon filters at \$47 box of 25

Table 6-4

RADON PASSIVE INTEGRATING MONITORS

<u>Trade Name/Model</u>	Charcoal Canister	Track-Etch	Passive Envir. Radon Monit.
<u>Manufacturer</u>	Environmental Measurements	Terradex	EPA Instruments, Inc.
<u>Address</u>	Lab of DOE 376 Hudson Street New York, New York 10014	460 North Wiget Lane Walnut Creek, CA 94598	5151 Ward Rd. Wheat Ridge, CO 80033
<u>Contact</u>	Andy George	Dr. H. Wald Alter	
<u>Telephone</u>	(212) 620-3653	(415) 938-2545	(303) 422-9112
<u>Collection Mechanism</u>	Diffusion/adsorption gamma detection	Alpha particle sensitive film	Diffusion/electrostatic field
<u>Sampling Time</u>	3 days - 1 week 4 days is best	At least 1 month	1 week - 1 month
<u>Range</u>	0-4 pCi/l	0-4 pCi/l	Depends on chip used
<u>Sensitivity</u>	0.07 pCi/1-day	0.2-1.0 pCi/1-month	0.03 pCi/1-week
<u>Accuracy</u>	±15%		Depends on chip used
<u>Cost</u>	~\$20	\$16.50 each for 4.0 pCi/1-month \$33 each for 1.0 pCi/1-month \$66 each for 0.2 pCi/1-month	\$595 each
<u>Analysis Requirements</u>	Sodium Iodine Analyzer Radioactive counter. Can be done by EML/DOE or Eberline Sante Fe, New Mexico.	Count number of alpha particles on developed film. Must be done by Terradex.	Thermoluminescence
<u>Analysis Cost</u>	N/A	Included in purchase price.	N/A

Table 6-5

CARBON MONOXIDE ACTIVE INTEGRATING MONITORS

<u>Trade Name/Model</u>	Personnel Dosimeter 15ECS1C02 Direct Reading Detector 15ECS3C03	Ecolyzer Model 2106/2108 Energetic Sciences, Inc. 6 Skyline Dr. Hawthorne, NY 10532	Model 1146 InterScan Corporation Box 2496 Chatsworth, CA 91311
<u>Manufacturer Address</u>	General Electric Company Aviation Service Operation 333 W. Seymour Ave. Cincinnati, OH 45216		
<u>Contact</u>	Nancy Fessler	Sue Scova	Richard Shaw
<u>Telephone</u>	(513) 948-5065	(914) 592-3010	(213) 882-2331
<u>Collection Mechanism</u>	Fuel cell electrochemical oxidation	Electrochemical oxidation	Electrochemical oxidation
<u>Sampling Time</u>	5 sec		~20 sec
<u>Range</u>	0-1000 ppm	0-1999 ppm	0-100 ppm
<u>Sensitivity</u>	1-2 ppm	1 ppm	1%
<u>Accuracy</u>	±2 ppm	±1 ppm	±2%
<u>Power Requirements</u>	Battery, 5 volts	Battery, 9 volts	Battery, 8 volts
<u>Cost</u>	\$803/\$1255	\$1900	\$1725
<u>Analysis Requirements</u>	Read-out from Support Console 15ECS2C05	N/A	Analog meter for recorder included
<u>Analysis Cost</u>	Support Console \$814/\$982	N/A	N/A

Section 7
MEASURING AND MODELING INFILTRATION

IN THIS SECTION: Techniques for measuring air infiltration--tracer gas and fan pressurization; effective leakage area; modeling air infiltration.

BASIC ISSUES

The difficulty in measuring and modeling infiltration lies in its dynamic nature. Because infiltration rates are weather-dependent, their values vary widely over time. The first measurements of infiltration used tracer-gas decay methods to establish the air exchange over short periods of time. Later, techniques were developed that allowed for continuous infiltration measurement, from several hours to up to a month. At present, several tracer-gas techniques are used, ranging from grab-sampling and miniature passive monitors to complex systems that measure multi-unit infiltration rates.

A different approach, fan pressurization, has been employed to measure the leakage area directly. This technique was developed in Sweden to determine whether houses were meeting levels of tightness specified in the building code. Leakage area, along with weather conditions and site characteristics, all serve as inputs to a model that predicts infiltration rates. The only variable missing is the effect of occupants.

Occupancy effects are one of the most difficult variables to determine in constructing an infiltration model. While other problems can be modeled, albeit simplistically, occupancy effects require a socio-physiological model of human comfort and behavior. Some studies have attempted to account for occupant effects by looking at patterns of window opening, but at present there is no reliable way to account for the confounding effects of occupant behavior.

MEASUREMENT STRATEGIES

Tracer-Gas Techniques

Several tracer-gas techniques exist for measuring infiltration,¹ but the one used most commonly is referred to as tracer-gas decay. This procedure involves injecting a known concentration of a gas (for example ethane, nitrous oxide, or sulfur hexafluoride) into a space and then measuring the decrease in gas concentration (its "decay") over time. Its rate of dilution indicates the rate at which outside air enters the structure. (The concentration of tracer gas outside the structure is assumed to be negligible.) Tracer gas can be monitored continuously with an analyzer (Figure 7-1) in the room, or grab samples can be taken at measured intervals for subsequent analysis.

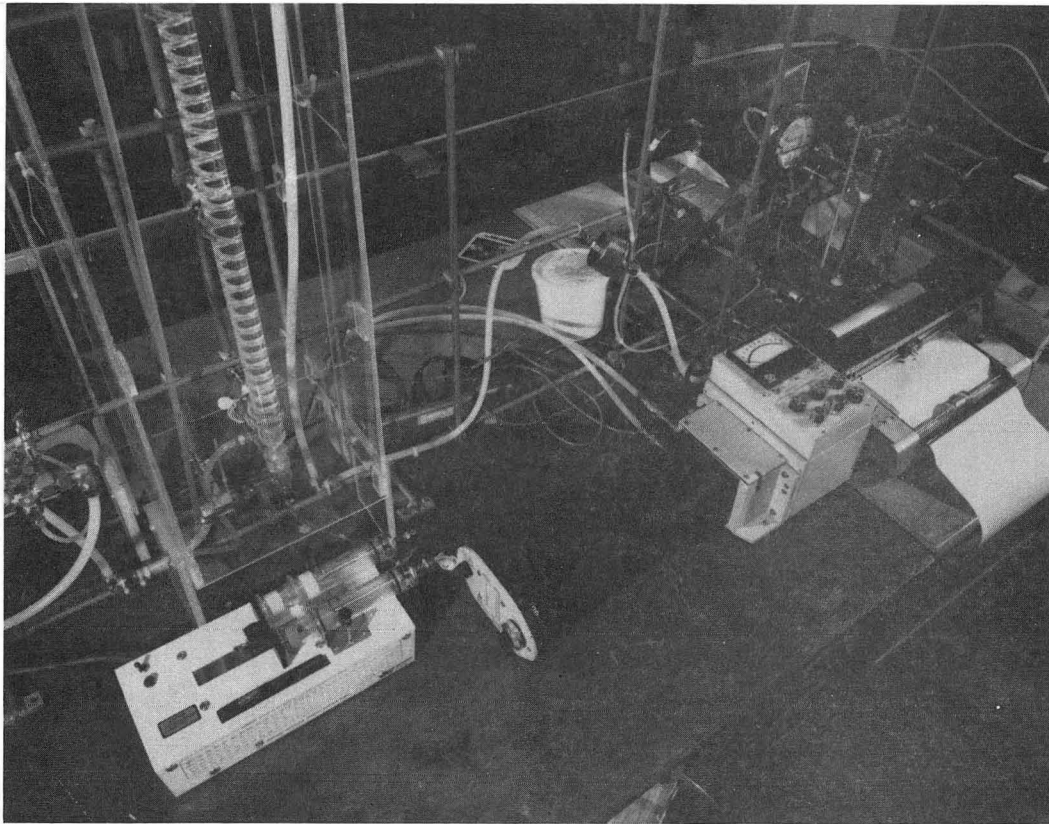

XBB 836-5382

Figure 7-1. Tracer-gas analyzer

The dilution of the gas occurs at an exponential rate, according to the equation:

$$C(t) = C_0 e^{-\frac{Q}{V} t} \quad (1)$$

where:

$C(t)$ is the average concentration of tracer gas at time, t ;

C_0 is the concentration at $t=0$;

Q is the infiltration (m^3/hr);

V is the volume of the space (m^3); and

Q/V is the infiltration rate (hr^{-1}).

Short-term measurements obtained through tracer-gas decay techniques, whether continuously measured or grab sampled, give infiltration rates for specific weather conditions that are not easily generalizable to different weather conditions. Figure 7-2 shows short-term tracer-gas measurements (note logarithmic scale).

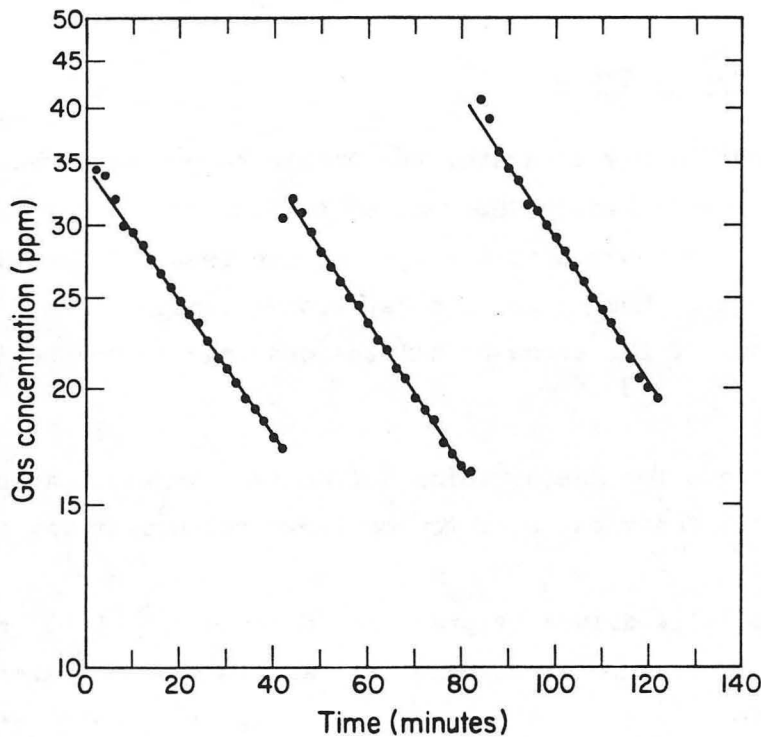

Figure 7-2. Tracer-gas decay

An alternative tracer-gas method that permits averaging over weather conditions is the long-term averaging technique. In this method, as the gas is injected into the

structure at a constant rate over an extended period of time, the air in the structure is sampled at a constant rate. Over the long term, if the injection rate is kept constant and the averaging interval is sufficiently long, the inverse of the average infiltration is equal to the average concentration divided by the tracer flow; that is:

$$\left[\frac{1}{Q} \right] = \frac{[C]}{F} \quad (2)$$

where:

Q is infiltration (m^3/hr)

C is the concentration

F is the flow of tracer gas into the structure (m^3/hr) and the square brackets [] denote a time average.

A portable, non-intrusive system based on this technique has been developed at Brookhaven National Laboratory.²

Fan Pressurization (Leakage Area) Tests

Tracer-gas methods, while relatively accurate, are unable to provide much information about the location of air leakage in houses, or to determine infiltration under weather conditions different from those at the time of the test. A useful index of the relative leakiness of a house is its "effective leakage area," a quantity roughly equivalent to the sum of the areas of all the openings in the building shell through which air is able to pass.³

Fan pressurization, a technique for determining effective leakage area, uses a door-mounted, variable-speed fan capable of moving large volumes of air into or out of a structure (Figure 7-3).

Natural infiltration is typically driven by pressure differences (ΔP) across the building shell in the range of 0 to 10 pascals (Pa) and is characterized by large, short-term fluctuations. When ΔP is held constant by the fan, all air flowing through the fan must also be flowing through the building shell. When ΔP is much greater than 10 Pa, fan flow dominates any variations that may be caused by wind-induced infiltration, which, consequently, can be disregarded. At a given pressure differential and fan speed (in RPM), the flow of air through the fan is determined by means of a previously established calibration curve. For each structure, measurements are taken under conditions of both pressurization and depressurization at a series of fixed pressure differentials (for example, from 10 to 70 Pa at 10 Pa intervals), generating a pressure-versus-flow curve. These data can then be used to

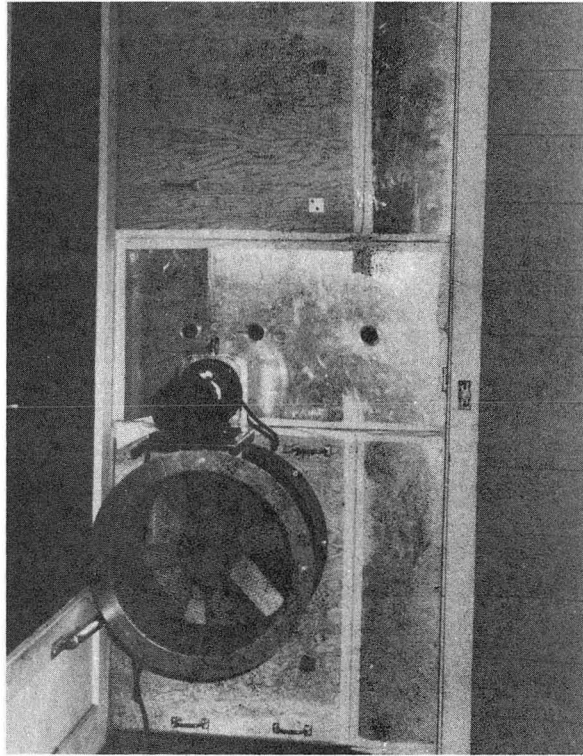

XBB 815-4519

Figure 7-3. Blower-door used for fan pressurization test

find the effective leakage area of the house. The derivation of these calculations is shown below.

Air flow through a building envelope may be thought of as a combination of pipe flow and orifice flow. The former is proportional to ΔP while the latter is proportional to the square root of ΔP . Hence, air flow through the shell can be characterized by the equation:

$$Q = K (\Delta P)^n \quad (3)$$

where:

- Q is air flow through the shell (m^3/hr);
- ΔP is the applied pressure across the building shell (Pa);
- K is an empirical constant; and

n is an empirical constant, in the range $0.5 < n < 1.0$.

The curves generated by fan pressurization tests are extrapolated to a ΔP of 4 Pa (assumed to be representative of natural infiltration) using Equation 3. Next, it is assumed that in the pressure differential ranges characteristic of natural infiltration (-10 to +10 Pa), the flow versus pressure behavior of the building shell more closely resembles orifice (square root) than pipe (linear) flow and thus can be described by the equation:

$$Q = A_{\text{eff}} \sqrt{\frac{2}{\rho} \Delta P} \quad (4)$$

where:

- Q is the air flow through the envelope (m^3/s) at 4 Pa,
- A_{eff} is the effective leakage area (m^2),
- ΔP is the applied pressure of 4 Pa ($\text{kg}/\text{m}\text{-sec}^2$), and
- ρ is the density of air ($1.2 \text{ kg}/\text{m}^3$ at sea level).

In this equation the effective leakage area (A_{eff}) characterizes the air leakage of a structure. This leakage area can then be used in an infiltration model (described below) to provide uncontrolled air exchange rates for the structure.

A new experimental technique for determining the leakage area at low pressures is called AC pressurization. AC pressurization is a technique that employs a fixed-frequency alternating source to vary the volume of the structure. The changes in volume cause fluctuations in the pressure of the air in the house. The amplitude of the pressure and the phase shift between the change in volume and the pressure signal determines the leakage area of the structure.⁴ This technique has several advantages over conventional fan pressurization with a blower door: (1) it is more precise, (2) it works in the 1-10 pascal range, and (3) it combines pressurization and depressurization results simultaneously.

MODELING INFILTRATION

Models of infiltration have been developed to answer several questions: (1) What is the environmental dependence of the infiltration process that would allow its magnitude to be calculated when weather information is known? (2) How does one extrapolate from short-term tracer-gas measurements to long-term values averaged over weather conditions? (3) What is the minimal set of measurements required to predict infiltration in a building? Many attempts at modeling infiltration have been made in the past, with mixed results. Virtually all the previous models have been either inaccurate or site-specific. One exception is a class of detailed models that

require such a large amount of information that they are impractical to use as predictive tools. Another is a recently developed model that sacrifices some accuracy for versatility and simplicity. Listed below are the types of models currently in use.

Constant Rate

The constant-rate model is the simplest of all; it assumes that the infiltration rate (i.e., the number of volumes per unit time) is a constant, independent of all other factors (e.g., weather, leakage occupancy, size, etc.). The simplicity of this model is appealing and, if one needs to calculate only the average performance of a large number of houses, this model will yield acceptable results. The appropriate infiltration value to use is the average value found in the houses in the region in question or, if regional information is not available, the average for the nation. However, if information about a particular house is needed, a better estimate must be made.

Air-Change Method

This model offers a slight improvement over the constant-rate model. It recognizes housing differences by focusing on the doors and windows in the structure; that is, each room is assumed to have a constant infiltration rate based on the number of existing exterior doors and windows; studies made on small buildings yield the values for this rate. Again, no attempt is made to measure or estimate either the leakiness of the envelope or the driving pressures across it.

Crack Method

The crack method, the first real attempt to estimate the leakage of the building envelope, assumes that the infiltration will be proportional to the total crack length or "crackage" and some pressure raised to an arbitrary power:

$$Q = C (\Delta P)^n \quad (5)$$

where:

Q is the infiltration (m^3);

C is the flow coefficient, a volumetric flow per unit crack length or leakage area at unit pressure difference;

ΔP is a "design pressure drop" (Pa); and

n is the exponent.

The exponent is usually assumed to be equal to 0.65. The pressure drop is a single number calculated by estimating the pressure caused by the difference in buoyancy between inside and outside air, and adding to that value the pressure caused by the wind. The flow coefficient is calculated by finding the length of crack associated with each door and window--i.e., the length of operable sash--and multiplying it by a tabulated quantity that reflects on the type of penetration (double-hung window, wall-frame leaks around masonry, etc.). Although this method attempts to use weather information to estimate the infiltration, it uses only design pressures and, therefore, cannot be used to estimate instantaneous infiltration, or even long-term average infiltration--only design infiltration. Furthermore, the estimation of crackage does not take into account the installation quality of fenestration or other building features. It has been found that installation practices and aging can each change the leakage behavior by a factor of two.

The above three methods have been used by designers and, until recently, have been the ASHRAE standard methods used to size equipment as well as to estimate infiltration. A review of these models has been prepared by J. Janssen.⁵

Linear Regression Techniques

Because they do not consider the instantaneous pressures across the envelope, the previous models are completely unable to predict real-time infiltration. Realizing that weather is the dominant driving force for infiltration, researchers attempted to fit the infiltration to the weather variables; that is, the infiltration was assumed to be linearly dependent on the temperature and wind speed:

$$Q = a + b \Delta T + c v \quad (6)$$

where:

- Q is the infiltration (m^3),
- ΔT is the inside-outside temperature difference (K),
- v is the wind speed (m/s), and
- a, b, c are regression constants.

In order to use this model, a great deal of data (infiltration, temperatures, and wind speed) are taken at a particular site and the constants--a, b, c--are adjusted to give the best fit to the data. Once the constants have been found, the above equation can be used to calculate the infiltration from the weather variables. Such regression equations have been found to be quite accurate for the site at which the data were taken;⁶⁻⁸ however, if the same constants are tried at another site, or if the weather variables are outside the range of the initial data, the results are

unreliable. Furthermore, because the regression constants have no physical meaning, it is impossible to formulate a method that converts one set of regression constants for one particular site into those for another site.

Because only the weather variables appear specifically, the effect of envelope leakage is not evident. While it can be assumed that the leakier the structure, the more the infiltration, a linear regression fit does not predict how the infiltration of the structure will change if the leakage of the envelope is decreased.

Detailed Models

Models are now being developed that perform very detailed calculations to find instantaneous infiltration. Basically, this type of model calculates the pressure distribution everywhere (maintaining self-consistency) and, from that pressure distribution, calculates the flow through each opening in the structure. This computation requires intimate knowledge of the location and characteristics of each leak (e.g., crack geometries and distribution, precise siting and terrain information,) as well as the information necessary to calculate the pressure drops. Although such detailed models can be made quite general and still be accurate, they require that a large body of information about the structure be acquired.

In one detailed model, the pressure drop across the envelope is explicitly measured and combined with leakage characteristics of the envelope to find the infiltration.⁹ This model can be accurate in predicting infiltration, but it requires constant monitoring of the pressures and, thus, it is clearly impractical for large-scale measurements.

Generally speaking, the large body of information required to determine infiltration makes these detailed models unsuitable for most applications. In a computer-design program, it would be not only unreasonable but impossible for a designer or engineer to specify the location and size of every crack. For field testing, assuming it were possible, it would take an unreasonable length of time to locate and characterize each leak. Detailed techniques, then, are most suited to intensive research applications.

Simplified Model

An infiltration model has been developed at Lawrence Berkeley Laboratory that sacrifices some accuracy for versatility and simplicity.¹⁰ The model spans the gap between the detailed models described above and the constant-value assumption that ignores all structural and environmental effects. Furthermore, the model predicts the impact of retrofits or other changes in the building envelope on the basis of

performance changes effected in the following measurable parameters:

- The leakage area(s) of the structure
- The geometry of the structure
- The inside-outside temperature difference
- The terrain class of the structure
- The wind speed

Using standard wind formulas, one can calculate the wind speed used by the model from a wind speed measured on any weather tower in the area, thus obviating the need for on-site weather collection. The only requirement is that the measured wind data be for the "same wind", i.e., there can be no mountains or other major obstructions in terrain between the site and the wind tower. This simplified model has been field-validated on a large number of houses; in long-term studies the predicted and measured values agree within $\pm 25\%$.

MULTICHAMBER EFFECTS

In a large structure like an office building or an apartment building, the assumption of a single well-mixed interior zone breaks down. In this case it is not sufficient to calculate the total amount of outside air that infiltrates the structure; what is important is to be able to calculate how much fresh air gets into each individual chamber, and even how much air is exchanged among the chambers. In these structures, then, a multichamber model is needed.

Much experimental work remains to develop an acceptable multichamber model. As yet, there exists no accurate method of measuring the actual infiltration in the multichamber case, nor is there a method of measuring the leakage between and among the chambers. The development and validation of a multichamber model awaits the solution of these problems.

REFERENCES

1. M.H. Sherman et al., "Air Infiltration Measurement Techniques," Lawrence Berkeley Laboratory report, LBL-10705, April 1980.
2. R.N. Dietz and E.A. Cote, "Air Infiltration Measurements in a Home Using a Convenient Perfluorocarbon Tracer Technique," Brookhaven National Laboratory report, BNL-30797, December 1981.
3. M.H. Sherman and D.T. Grimsrud, "Measurement of Infiltration Using Fan Pres-

surization and Weather Data," Lawrence Berkeley Laboratory report, LBL-10852, October 1980.

4. M.H. Sherman, D.T. Grimsrud, and R. C. Sonderegger, "The Low Pressure Leakage Function of a Building," in Proceedings of the ASHRAE/DOE Conference: Thermal Performance of the Exterior Envelopes of Buildings, Orlando, Florida, 1979, p. 94-121.
5. J.E. Janssen, "Calculating Infiltration: An Examination of Handbook Models," ASHRAE Transactions 86, II, 1980.
6. D.R. Bahnfleth, D.T. Moseley, and W.S. Harris, "Measurement of Infiltration in Two Residences," ASHRAE Transactions 63, 439-452, 1957.
7. J.B. Dick and D.A. Thomas, "Ventilation Research in Occupied Houses," J. Inst. Heat. Vent. Eng. 19, 306-332, 1951.
8. N. Malik, "Field Studies of Dependence of Air Infiltration on Outside Temperature and Wind," Energy and Buildings 1, 281-292, 1978.
9. D.T. Grimsrud et al., "Infiltration-Pressurization Correlations: Detailed Measurements on a California House," ASHRAE Transactions 85, I, 851-865, 1979. Lawrence Berkeley Laboratory report LBL-7824, March 1978.
10. Sherman, 1980, op. cit.

Section 8
POLLUTANT CONTROL

IN THIS SECTION: Pollutant control techniques; source control; ventilation/dilution; air cleaning; future technologies.

BASIC ISSUES

Strategies for controlling contaminant levels indoors are generally assigned to one of two broad categories: those that remove the pollutant at its source (or block its entry to the building), and those that reduce pollutant concentrations (commonly by means of ventilation or various air-cleaning devices). The methods used vary according to the pollutant(s) in question and range from complex and costly solutions (e.g., earth removal in the case of large-scale radon contamination) to relatively simple remedies (such as switching from combustion to electric appliances or eliminating tobacco smoking from the home). In the material that follows, we first present each strategy and then discuss briefly the problems associated with its use in controlling the key pollutants under consideration here.

SOURCE CONTROL

In many cases, the sources of indoor air pollutants can be excluded or removed from a residence, isolated from the indoor air, or modified so that their pollutant emission rate is decreased. Because source removal is usually a permanent, one-time measure that entails no maintenance or operating costs, it is the preferred control measure whenever practical. In some cases, however, source control strategies are too costly, invite substitute products that may also be sources of indoor pollution, or impose difficult demands on occupants (e.g., giving up tobacco smoking or shifting to unfamiliar appliances).

Radon

Removal of radon sources can involve the removal and replacement of concrete, masonry, or brick building materials, or removal of the soil surrounding the basement, slab floor, or crawlspace. Far from simple, removal of these materials is generally undertaken only when surveys have determined that the radium content in the building materials or surrounding soil is hazardous. On the other hand, these techniques have been used successfully in individual homes found to have high radon levels. In rural areas, tap water from wells can be a significant source of radon. In such cases, homeowners can switch to a different water supply or aerate or store the water outdoors for a few days to allow the radon to decay. In general, buildings should not be constructed out of materials with high radium content or in areas in which the radium content of the soil is high. When high levels are found after construction, removal or control of radon entry must be considered.

The most common technique for controlling radon is to reduce its transport into the building by sealing materials known to have significant emanation rates or, for surrounding soil, to plug cracks or holes through which soil gas moves into the house. Surfaces of concrete walls and concrete slab floors can be sealed with commercially available polymeric and epoxy sealants.¹⁻⁴ Cracks in building foundation walls, gaps between walls and floors, and drain holes can be filled with nonporous materials, or covered and sealed with plastic sheets.⁵⁻⁷ The general applicability or effectiveness of these measures as long-term controls is not known, but, in short-term studies, these control measures have proved highly effective.

Formaldehyde

Removal and replacement of building materials that emit formaldehyde is, again, an expensive control technique. The best solution is to use construction materials that are not made with formaldehyde-containing resins. Reducing formaldehyde emanation at its source, however, is possible. In laboratory studies, for example, the application of various paints, lacquers, varnishes, and vinyl papers to particleboard has significantly reduced the rate of formaldehyde emission.⁸⁻¹⁰ These coatings generally do not work as barriers; rather they contain scavengers that react with formaldehyde and thus prevent its release into the surrounding air. The effectiveness of surface coatings applied to the exposed surfaces of particleboard, once installed, is not known.

Two relatively simple procedures used effectively in individual houses having formaldehyde problems are ammonia fumigation and dehumidification, both of which reduce the rate of formaldehyde emission from building materials. For the ammonia fumigation technique, ammonium hydroxide is placed in shallow pans in every major room of the residence. The home is sealed and maintained at a temperature of 27 °C or higher for at least 12 hours while fans circulate the indoor air. Jewell used this technique in 12 mobile homes and reported 45 to 90% initial reductions in formaldehyde levels, and 39 to 81% reductions in four homes monitored after a 40- to 60-week period.¹¹ Jewell, reporting formaldehyde concentrations for a year after fumigation treatment, found that concentrations appear to return to values typical of long-term decay of emission rates from materials.

Although no studies have been performed in actual homes to determine the effects of dehumidification on indoor formaldehyde concentrations, laboratory studies suggest that this procedure may be useful in obtaining moderate decreases. Birge et al., reporting the results of recent tests in a climate-controlled chamber containing particleboard, report that formaldehyde levels decreased 17.5% for every 10% reduction in relative humidity.¹² (The authors assumed a linear relation between formaldehyde level and relative humidity; however, their results are reported for only two relative humidities.) Similar experiments performed by Anderson et al., at several humidities, indicate a linear relation between formaldehyde concentration and humidity ratio, i.e., mass of water vapor/mass of air.¹³ In their studies, when the chamber temperature was maintained at 22 °C and the air exchange rate at 0.5 ach, a decrease in relative humidity from 70 to 30% caused a 50% decrease in formaldehyde levels. A study by Long et al. indicates that the release of formaldehyde from urea-formaldehyde foam insulation is also reduced when humidity is lowered.¹⁴

Dehumidification can be effected by using residential dehumidifiers, by placing ventilation devices near humidity sources (e.g., bathroom fans exhausted to outside), or by opening the house to outdoor air when the outdoor air is less humid than indoor air.

Combustion Products

Removing any unvented combustion appliance is an obvious technique for eliminating the emission of combustion products into the indoor air. If they are poorly maintained (e.g., if a furnace has a cracked heat exchanger) or if the vent system is damaged or faulty, even vented combustion appliances can be a significant source of indoor pollutants. Beyond replacing or adjusting combustion appliances that are

faulty, or switching to electrical appliances (which may not be a desired alternative for all homeowners), control strategies that fall into the second category--reducing pollutant concentrations--are simpler to apply with combustion by-products.

An important control strategy that can be regarded as source control and as ventilation is the use of local ventilation, as, for example, is provided by a range hood fan. In operation, the fan effectively isolates the source from the occupied spaces. This technique is discussed in greater detail in the following section on ventilation.

VENTILATION

Ventilation (replacing stale indoor air with fresh outdoor air) is the most common method of reducing the levels of indoor-generated air pollutants. Ventilation can be local or distributed, periodic or continuous, natural or mechanical, and accomplished with or without heat recovery. A significant advantage of ventilation is that it reduces levels of almost all indoor air pollutants, assuming outdoor concentrations are less than the indoor concentrations.^{15,16} The reduction in radon level due to an increase in air exchange is shown in Figure 8-1.

[Note: Ventilation may be more effective for some pollutants than for others. A few studies have suggested that increasing the ventilation rate is only partially effective in reducing formaldehyde levels because lowered formaldehyde concentrations increase the rate of formaldehyde emission from building materials.¹⁷⁻¹⁹ Furthermore, models for indoor air quality indicate that increasing ventilation causes a smaller decrease in the concentration of a reactive air pollutant than in that of a non-reactive pollutant.²⁰ Examples of reactive pollutants are nitrogen dioxide, formaldehyde, and those particles that are removed from indoor air by interacting with indoor surfaces.] Three ventilation strategies are discussed below: natural, local, and mechanical.

Natural Ventilation

The simplest ventilation technique, of course, is to bring in fresh outside air by opening windows and doors. Although this approach (often referred to as "natural ventilation") may work when the area is small and the need is but for a short time, it clearly adds to the heating (or cooling) load and, on any large or continuous scale, can be extremely energy-consuming. Natural ventilation is also an ineffective way to remove pollutants from a point source, far more effectively accomplished by spot ventilation, such as provided by exhaust fans in bathrooms and range fans in

INDOOR RADON CONCENTRATION

Energy Research House
With Mechanical Ventilation
Carroll County, Maryland

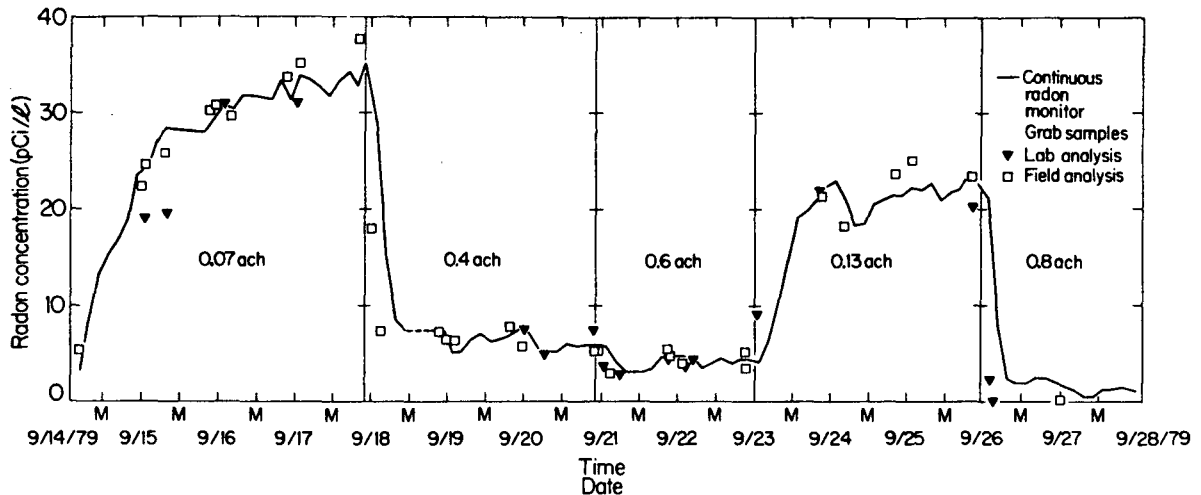

Figure 8-1. Effect of ventilation on radon levels

kitchens.

Local Ventilation

A significant source of concentrated and periodically released indoor air pollutants is the operation of a gas stove. In a study by Traynor et al., use of a range hood fan effected 60 to 87% reductions in the amount of CO, CO₂, and NO_x entering the occupied space of an experimental test house.²¹ In their study, the flow rate of air exhausted through the range hood was varied from 150 to 420 m³/hr. In a study by Macriss and Elkens, a range hood with exhaust rates of 120 to 400 m³/hr caused 40 to 50% reductions in average incremental NO₂ levels.²² (Average incremental NO₂ level describes the increase in average NO₂ level due to operation of a gas stove.) Although the performance of range hoods depends somewhat on airflow rates and methods of installation, they are generally quite effective in reducing the entry of combustion by-products into the occupied space. The important issue here is that occupants use them when cooking.

Mechanical Ventilation with Air-to-Air Heat Exchangers

An alternative ventilation strategy is to tighten up the shell of the house and bring in a controlled supply of fresh air by means of mechanical ventilation. Such devices come equipped with an air-to-air heat exchanger to assure recovery of heat that would otherwise be a costly loss. Referred to simply as residential air-to-air heat exchangers, these devices can be elaborate--a fan assembly with ductwork installed in an attic or crawlspace--or simple--a ductless unit installed through the wall or window much like a window air conditioner.²³ Appendix A contains a list of U.S. and Canadian sources for residential air-to-air heat exchangers. The way in which air-to-air heat exchangers recover the heat contained in the outgoing air stream and transfer it to the incoming air stream is shown in Figure 8-2.

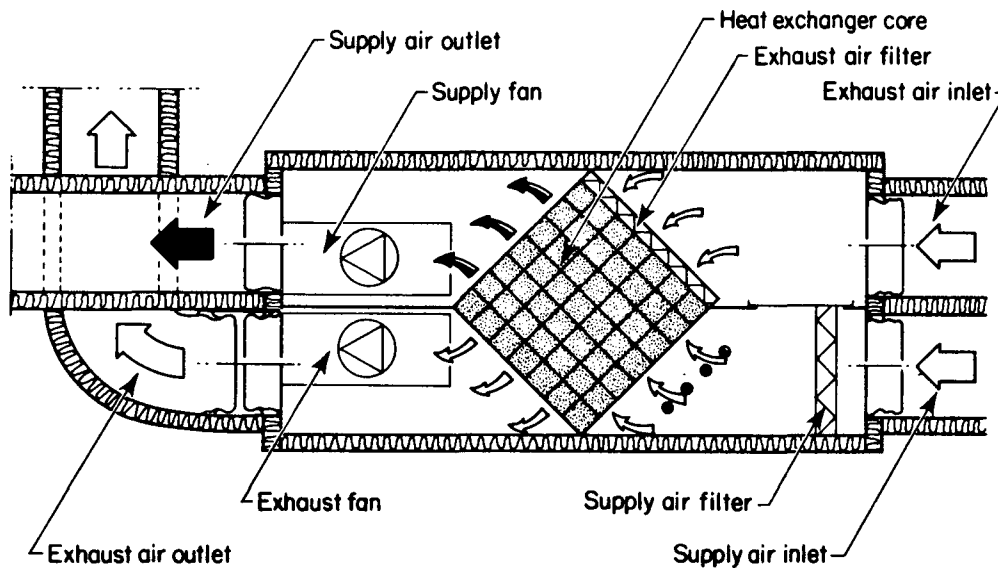

Figure 8-2. Mechanical ventilation system with air-to-air heat exchanger

Heat-recovery efficiencies of up to 85% make them attractive to energy-conscious homeowners. Fan power consumption is highly variable, and can in some cases significantly reduce energy savings.^{24,25}

Field studies have demonstrated the effectiveness of such mechanical ventilation systems in reducing indoor pollutants. Offermann et al. measured the concentration of radon and formaldehyde (nine houses) and particles (two additional houses) for two 10-day periods, with and without mechanical ventilation.²⁶ They found that the average increase in air exchange rate (from 0.35 to 0.63) due to the mechanical ventilation produced a decrease in the average radon concentrations of 50%, in the average formaldehyde concentration 18%, and in particles 30%. An important finding from this study was that the degree to which pollutant concentrations are reduced may depend on certain characteristics of the duct system used with the device, and on the location(s) of pollutant sources.

The cost-effectiveness of mechanical ventilation systems is important; larger systems can be expensive to install. Fisk and Turiel evaluated the energy savings that accrued from operating mechanical ventilation systems equipped with air-to-air heat exchangers in new homes, and also performed a cost-benefit analysis for homeowners.²⁷ They found cost-effectiveness to be highly influenced by equipment performance, climate, and type of heating fuel used. Fisk and Turiel conducted a similar analysis on installations of unducted systems in weatherized homes.²⁸

A second method of providing mechanical ventilation to residences involves using mechanical exhaust ventilation with or without heat recovery by a heat pump. In this technique, a fan exhausts indoor air, thereby drawing outdoor air into the house through cracks or slats in the walls. If the exhaust air is passed through a small heat pump, the energy that would be lost can be recovered. The heat pump generally transfers energy from the outgoing air to the domestic hot-water supply; however, exhaust-air heat pumps that also transfer energy to the indoor air are available. Exhaust-air heat-pump systems are gaining popularity in Sweden, but have not yet been used in the United States.²⁹

AIR CLEANING

The term "air cleaning" refers to methods of removing pollutants from indoor air without ventilation. Air-cleaning methods that may be suitable for controlling indoor pollution are: filtration, electrostatic precipitation, ionization, absorption, and adsorption. Each method of air cleaning is discussed briefly below; for more detailed information, appears elsewhere;³⁰⁻³⁴ see also Appendix B. Typical air cleaners are shown in Figure 8-3.



CBB 836-5337

Figure 8-3. Typical air cleaners

Air Filtration

Air filtration is accomplished by passing the air through a filter, usually constructed from a woven fabric, a paper material, or a fibrous mat. Filters, as defined here, are designed to remove particles (aerosols) and are generally not effective in removing gaseous contaminants. Radon, for example, as an inert gas, will not be removed by filters, but radon progeny, a large fraction of which attach to particles, are effectively removed by filtration.³⁵ Filters are characterized by their particle-collection efficiency (which varies with particle size), their air-flow resistance, and their capacity (i.e., lifetime). High-efficiency filters can remove almost 100% of particles as small as $0.3 \mu\text{m}$; on the other hand, the coarse fibrous-mat filters typically used in residential furnace systems are not effective in removing the submicron-size particles that are of primary health concern. Filter systems with a wide variety of efficiencies are commercially available. A recent product that may be more suitable than conventional filters for removing small particles is a filter that contains fibers having a permanent electrical charge (called electrets). Filters must be periodically cleaned or replaced, and significant trade-offs exist between filter cost, collection efficiency, capacity, and airflow

resistance. The filters and other particulate control devices described below may be effective in removing aerosols from indoor air; however, if the aerosols are volatile (such as tobacco smoke aerosols, which are primarily a liquid) then gases and odors may be emitted into the indoor air from the collected aerosols.

Electrostatic Precipitators

Electrostatic precipitators can be highly effective in removing even submicron particles from indoor air, but generally are not effective in removing gaseous contaminants. Residential-sized precipitators are readily available for installation in furnace ductwork and walls, and some are portable models. One advantage of precipitation is that, unlike filtration, small particles can be removed without requiring fan power to impart a large pressure drop to the airstream. Another advantage is that collection surfaces of precipitators can usually be cleaned with soap and water and, in some models, in an automatic dishwasher. High-efficiency filters, on the other hand, must be replaced periodically. In an electrostatic precipitator, particles are first charged by gaseous ions produced by an electrical corona discharge. The charged particles then pass through an electric field and are attracted to and collected by an oppositely charged electrode. Some precipitators produce a small amount of ozone; many units are supplied with replaceable charcoal filters to remove the ozone.

Air Ionizers

Air ionizers produce large numbers of negative ions, some of which attach to particles in the air and convey a negative electrical charge to the particles. The particles then attach to walls, floors, and other surfaces, which usually have lower electrical potential. The principle is the same as with electrostatic precipitators: substances with different electrical charges are attracted to each other. A criticism of negative-ion generators is that many models do not entirely remove the offending particles; rather, they remove them from the air and deposit them on surfaces around the room. Some recent models are equipped with positive-charged collectors that are supposed to attract and capture most of the particles. The performance and usefulness of ionizers is presently a controversial topic because of questionable medical and advertising claims. Nevertheless, they can be somewhat effective at removing particles from the air.

Absorption

Absorption processes, generally used in industrial plants to remove gaseous contaminants, have received little consideration as a control strategy for residential indoor pollutants. The terms "scrubbing" and "air-washing" are commonly used to describe absorption processes that work by passing contaminated air through a liquid spray or over wetted surfaces. Only pollutants that are soluble or chemically reactive to the liquid can be removed by absorption techniques. Absorption by water appears most promising for removing formaldehyde, which reacts readily with water. Various absorption processes are used by industry to absorb nitrogen dioxide (NO_2) from contaminated air;³⁶ however, the processes are complex and generally not suitable for indoor residential air where the concentrations of NO_2 are much lower. Absorption of NO_2 into water may be possible if additives to the water are used³⁷ but at this time the process appears impractical for indoor use. Absorption processes appear least promising for radon, which is non-reactive and only slightly soluble in water.

Adsorption

Adsorbents, in contrast to liquid absorbents, are porous solids that trap pollutants in the numerous pores on their surface. The exact mechanisms of adsorption are not fully understood. Gases having high molecular weights are generally adsorbed more easily than gases having low molecular weights. The most commonly used adsorbents are activated carbon (activated charcoal), activated alumina, silica gel, and molecular sieves. In many cases, adsorbents are impregnated with a material that improves their adsorption of a particular pollutant. Adsorbents become saturated after a period of use and must be regenerated or replaced.

The effectiveness of adsorbents in removing radon and nitrogen dioxide from indoor air is unknown. In the case of formaldehyde, however, Jewell³⁸ and others have investigated the use of Purafil (an aluminum oxide impregnated with potassium permanganate) as an adsorbant. Jewell reduced the levels of formaldehyde in a mobile home from approximately 500 parts per billion (ppb) to 140 ppb by passing 2640 m^3/hr of indoor air (equivalent to 13.6 air changes per hour) through a 36-kg bed of Purafil. Eriksson et al. compared the effectiveness of Purafil and other adsorbents (activated carbon, activated aluminum oxide, treated calcium carbonate, and activated aluminum oxide impregnated with potassium permanganate) in removing formaldehyde (in typical indoor concentrations) from the air./c³⁹ Their tests included a study of the lifetime (capacity) of the adsorbents and a study of a passive

adsorbtion technique. They concluded that only Purafil and the ceramic material impregnated with potassium permanganate showed promise for controlling indoor formaldehyde. In an attempt to increase the lifetime of the Purafil, they are experimenting with using activated carbon upstream of the Purafil.

FUTURE CONTROL TECHNIQUES

In the future, indoor contaminants will be controlled both by advanced design of products and by more sophisticated contaminant-removal strategies. Mechanical ventilation of residences will become more popular. Improved burner design for gas appliances will reduce pollutant emissions as well as lower fuel consumption. By lowering the maximum flame temperatures and combustion chamber temperatures, the emission of nitrogen oxides can be reduced. Building materials will be manufactured so that they emit less formaldehyde. Building designs may be modified so that the rate of radon entry into the indoor air is decreased. Techniques that may be used more commonly in the future are electrostatic precipitation, more effective adsorbents, catalytic conversion, and perhaps other decomposition processes. Sensors capable of activating the ventilation system when pollutant levels increase to unacceptable levels are under development and may also play an important role.

REFERENCES

1. E.M. Krisiuk et al., A Study on Radioactivity in Building Materials, Leningrad Research Institute for Radiation Hygiene, Leningrad, 1971.
2. M.V.J. Culot and K.J. Schiager, Radon Progeny Control in Buildings, Colorado State University report, COO-2273-1, 1973.
3. J.A. Auxier et al., "Preliminary Studies of the Effects of Sealants on Radon Emanation from Concrete," Health Physics 27, 390-391, 1974.
4. M.V.J. Culot, K.J. Schiager, and H.G. Olsen, "Development of a Radon Barrier," Health Physics 35, 375-380, 1978.
5. Atomic Energy Control Board, Canada, Workshop on Radon and Radon Daughters in Urban Communities Associated with Uranium Mining and Processing, Elliott Lake, Ontario, March 7-9, 1978.
6. Atomic Energy Control Board, Canada, Second Workshop on Radon and Radon Daughters in Urban Communities Associated with Uranium Mining and Processing, Bancroft, Ontario, March 12-14, 1979.
7. Atomic Energy Control Board, Canada, Third Workshop on Radon and Radon Daughters in Urban Communities Associated with Uranium Mining and Processing, Port Hope, Ontario, March 12-14, 1980.
8. B. Sudin, "Formaldehyde Emission from Particleboard and Other Building Materials: A Study from the Scandinavian Countries," presented at the Particleboard Series Symposium No. 12, Washington State University, April 4-6, 1978.

9. E. Roffael, "Progress in Elimination of Formaldehyde Liberation from Particleboards," presented at the Particleboard Series Symposium No. 12, Washington State University, April 4-6, 1978.
10. Malygina, "The Effect of Cladding and Additional Thermal Processing on Emission of Harmful Substances from Sheets Made of Wood Shavings and Manufactured on a Base of Urea Resin" (translated from Russian), Gigiena i Sanitariya 39 (8), 95, 1974.
11. R.A. Jewell, "Reduction of Formaldehyde Levels in Mobile Homes," presented at the Adhesive and Sealants Council's 1981 Fall Seminar, Philadelphia, Pennsylvania, October 1981.
12. A. Birge et al., "Formaldehyde Release from Particleboard--Evaluation of a Mathematical Model," Holz als Roh-und Werkstoff 38, 251-255, 1980.
13. I. Anderson, G.R. Lundqvist, and L. Molhave, "Indoor Air Pollution Due to Chipboard Used as a Construction Material," Atmospheric Environment 9, 1121-1127, 1975.
14. K.R. Long et al., "Problems Associated with the Use of Urea-Formaldehyde Foam for Residential Insulation, Part 1: The Effects of Temperature and Humidity on Formaldehyde Release from Urea-Formaldehyde Foam Insulation," Oak Ridge National Laboratory report, ORNL/SUB-7559/I, September 1979.
15. F.J. Offermann et al., "Residential Air Leakage and Indoor Air Quality in Rochester, New York," Lawrence Berkeley Laboratory report, LBL-13100, June 1982.
16. W.W. Nazaroff et al., "The Use of Mechanical Ventilation with Heat Recovery for Controlling Radon and Radon Daughter Concentrations in Houses," Atmospheric Environment 15, 263-270, 1981.
17. A. Birge et al., op. cit.
18. I. Anderson, G.R. Lundqvist, and L. Molhave, "Indoor Air Pollution Due to Chipboard Used as a Construction Material," Atmospheric Environment 9, 1121-1127, 1975.
19. I. Turiel et al., "The Effect of Reduced Ventilation on Indoor Air Quality in an Office Building," Lawrence Berkeley Laboratory report, LBL-10479, June 1981.
20. G.W. Traynor et al., "The Effects of Ventilation on Residential Air Pollution Due to Emissions from a Gas-Fired Range," Environment International 8, 447-452, 1982.
21. Ibid.
22. R.A. Macriss and R.H. Elkins, "Control of the Level of NO_x in the Indoor Environment," presented at the Fourth International Clean Air^x Congress, Tokyo, Japan, May 16-20, 1977.
23. W.A. Shurcliff, Air-to-Air Heat Exchangers for Houses, Andover, Mass: Brick House, 1982.
24. W.J. Fisk, G.D. Roseme, and C.D. Hollowell, "Performance of Residential Air-to-Air Heat Exchangers: Test Methods and Results," Lawrence Berkeley Laboratory report, LBL-11793, September 1980.

25. F.J. Offermann et al., 1981, op cit.
26. W.J. Fisk and I. Turiel, "Residential Air-to-Air Heat Exchangers: Performance, Energy Savings, and Economics," Lawrence Berkeley Laboratory report, LBL-13843, February 1982.
27. I. Turiel and W.J. Fisk, "Energy Savings and Cost-Effectiveness of Heat Exchanger Use as an Indoor Air Quality Mitigation Measure in the BPA Weatherization Program," Energy 8 (5), 323-335, 1983.
28. G. Gezelius, "Soon There Will Be 50,000 SEX-Ventilation Systems Installed in Single Family Houses in Sweden," Summary 55:1981 Swedish Council for Building Research, Sankt Goransgatan, 66, 5-122 33, Stockholm, Sweden.
29. A.C.Stern, Engineering Control of Air Pollution, London: Academic Press, 1977.
30. M. Crawford, Air Pollution Control Theory, New York: McGraw Hill, 1976.
31. W. Strauss, Industrial Gas Cleaning, New York: Pergamon Press, 1975.
32. R.E. Treybal, Mass Transfer Operations, New York: McGraw Hill, 1980.
33. American Society of Heating, Refrigerating, and Air Conditioning Engineers, ASHRAE Handbook and Product Directory--Equipment, Atlanta: ASHRAE, 1979.
34. F.J. Offermann et al., "Control of Respirable Particulates and Radon Progeny with Portable Air Cleaners," Lawrence Berkeley Laboratory report, LBL-16659, 1983.
35. Tennessee Valley Authority, "Technical Assessment of NO_x Removal Processes for Utility Application," prepared for the Electric Power Research Institute and the Environmental Protection Agency, EPRI AF-568, EPA-600/7-77-127, March 1978.
36. S.E. Schwartz and W.H. White, "Kinetics of the Reactive Dissolution of the Nitrogen Oxides and Oxyacids in Aqueous Solution," Brookhaven National Laboratory report, BNL 30178, November 1981.
37. Jewell, 1981, op. cit.
38. B. Eriksson et al., "Filtration of Formaldehyde Contaminated Indoor Air," presented at the Nordtest Symposium on Air Pollution Abatement by Filtration and Respiratory Protection, Copenhagen, Denmark.

APPENDIX A

U.S. and Canadian Sources for Residential
Air-to-Air Heat Exchangers

MANUFACTURER OR DISTRIBUTOR	TYPE OF HEAT EXCHANGER
Air Changer Corporation Attn: Greg Allen 334 King Street E. Studio 505 Toronto, Ontario Canada M5A 1K8 (416) 863-1762	Plastic counterflow with fans and freeze protection
Aldes Riehs U.S.A. 157 Glenfield Road Sewickley, PA 15143 (412) 741-2659	Plastic counterflow with fans; air distribution system available
Automated Controls & Systems Attn: Ray Kollock 500 East Higgins Road Elk Grove, IL 60007 (312) 860-6860	Crossflow core only
Berner International Attn: John Fischer 216 New Boston St Woburn, MA 01801 (617) 933-2180	Window/wall mounted; heat wheel with fans
Bik Products Incorporated Attn: James Meyer Engineered Products Division 42-44 Main Street P.O. Box 761 Danbury, CT 06810 (203) 743-1431	Regenerator, flow alternates over heat accumulators; with fans and freeze protection
Conservation Energy Systems, Inc. Box 8280 Saskatoon, Saskatchewan Canada S7K 6C6 (306) 665-6030	Plastic crossflow with fans and freeze protection
Des Champs Labs Incorporated Attn: Nicholas Des Champs P.O. Box 348 East Hanover, NJ 07936 (201) 884-1460	Aluminum counterflow with fans

MANUFACTURER OR DISTRIBUTOR

TYPE OF HEAT EXCHANGER

Enercon Industries Limited
Attn: Dennis Rogoza
2073 Cornwall Street
Regina, Saskatchewan
Canada S4P 2K6
(306) 585-0022

Plastic counterflow with
fans; freeze protection
available

Flakt Products Incorporated
Attn: Fulton Cooke
P.O. Box 21500
Fort Lauderdale, FL 33335
(305) 524-6521

Aluminum crossflow with
fans; freeze protection
available

Mitsubishi Electric Sales
America, Inc.
Attn: Mike Thomas
3030 East Victoria Street
Compton, CA 90221
(213) 537-7132
(800) 421-1132

Crossflow with paper,
aluminum, or plastic
cores; with fans;
wall/window mounted units
and ducted units available;
freeze protection available
for some units

Q-Dot Corporation
Attn: Axel Bucher
726 Regal Row
Dallas, Texas 75247
(214) 630-1224

Heat-pipe core only

APPENDIX B

Manufacturers of Air Cleaning Devices

I. FLAT-PLATE ELECTROSTATIC PRECIPITATORS

Five Seasons Comfort Limited
400 Eddystone Ave.
Downsview, Ontario
Canada M3N1H7
(416) 742-0601

Honeywell, Inc.
10400 Yellow Circle Drive
Minnetonka, MN 55343
(612) 931-4200

Oster
5055 North Lydell Avenue
Milwaukee, WI 53217
(414) 332-8300

Smokemaster Inc.
965 North County Road 18
Minneapolis, MN 55441
(612) 544-4426

Summit Hill Laboratories
Avalon, NJ 08202
(609) 967-4404

Trion, Inc.
P.O. Box 760
Sanford, NC 27330
(919) 775-2201

Universal Air Precipitation Corp.
1500 McCully Rd
Monroeville, PA 15146
(412) 351-3326

II. UNCHARGED MECHANICAL FILTERS

Air Techniques Inc.
1717 Whitehead Road
Baltimore, MD 21207
(301) 944-6037

Airomax Corp.
P.O. Box 86
Gibbstown, NJ 08027
(609) 933-1780

AllerMed Corporation
4324 Sunbelt
Dallas, TX 75248
(214) 248-0782

Peris Industries Inc.
P.O. Box 1008
State College, PA 16801
(814) 237-6820

Summit Hill Laboratories
Avalon, NJ 08202
(609) 967-4409

III. CHARGED FAN FILTERS

Air Control Industries, Inc.
213 McLemore St.
Nashville, TN 37203
(615) 242-3448

Bionaire Corp
P.O. Box 14
Paterson, NJ 07507
(201) 423-2661

Neo-Life Company of America
25000 Industrial Boulevard
Hayward, CA 94545
(415) 357-6226

North American Phillips Corp.
Consumer Products Division
High Ridge Park
Stamford, CT 06904
(203) 329-5700

Oreck Corp.
100 Plantation Road
New Orleans, LA 70123
(504) 733-8761

INDEX

Absorption 8-10
Active samplers 6-7
Adsorption 8-10
Air, composition 3-1
Air cleaners 8-7
Air contaminants 3-1
Air exchange 2-1, 2-3
Air leaks 2-2
Air quality models 6-1, 6-9
Asbestos 4-10, 5-13
ASHRAE Standard 62-1981 2-8, 5-1

Building envelope 3-6
Building materials 3-6, 4-4

Carbon dioxide 5-12
Carbon monoxide 4-6, 4-10, 5-12
Combustion products 3-6, 4-6, 5-12, 8-4
Contaminant removal 8-2f
Continuous monitoring 6-4
Control of indoor contaminants 8-1f

Design factors 3-6
Diffusion 3-4

Electrostatic filters 8-9
Energy conservation 1-2, 2-1
Energy costs 2-5

Fan pressurization 7-4
Field measurements 4-5
Filters 8-8
Fireplaces 4-8
Formaldehyde 4-3f, 5-8, 8-2, 8-7, 8-10
Furnishings 4-4

Gas stoves 4-7
Grab sampling 6-2

Health effects 5-1f
Heat exchangers (see mechanical ventilation)

Ionizers 8-9
Infiltration 2-2, 7-1f
Infiltration rates, US houses 2-4
Insulation (UF foam) 4-4
Integrated sampling 6-3

Leakage area 2-6, 7-3
Local ventilation 8-5

Mechanical ventilation 8-6
Minimum Property Standards (HUD) 2-8
Mobile homes 4-5, 8-10

Natural ventilation 8-4f
Nitric oxide 4-6, 5-13
Nitrogen dioxide 4-6f, 5-13, 8-10
Nitrogen oxides 4-6, 5-13

Occupants 3-7, 7-1
Organic compounds 3-6, 5-14
OSHA 5-2
Ozone 3-4

Particleboard 3-6, 4-5
Particulates 5-13f
Passive samplers 6-1, 6-7
Passive smoking 4-9
Personal monitors 6-7
Pesticides 5-15
Plywood 4-5

Radon 4-1f, 5-2f, 8-1f
Radon daughters 4-1, 8-8
Respirable particles 4-9
Retrofit techniques 2-7

Sources of air pollutants 3-4f
Space heaters 4-7
Sulfur dioxide 3-4, 4-8

Tobacco smoke 4-9
Tracer gas techniques 7-2

Variability 3-2f
Ventilation 2-2, 8-4
Ventilation standards 2-7f

Wood stoves 4-8
Working level 5-5

This report was done with support from the Department of Energy. Any conclusions or opinions expressed in this report represent solely those of the author(s) and not necessarily those of The Regents of the University of California, the Lawrence Berkeley Laboratory or the Department of Energy.

Reference to a company or product name does not imply approval or recommendation of the product by the University of California or the U.S. Department of Energy to the exclusion of others that may be suitable.

TECHNICAL INFORMATION DEPARTMENT
LAWRENCE BERKELEY LABORATORY
UNIVERSITY OF CALIFORNIA
BERKELEY, CALIFORNIA 94720