

Lawrence Berkeley National Laboratory

Lawrence Berkeley National Laboratory

Title

An integrated mechanical design concept for the final focusing region for the HIF point design

Permalink

<https://escholarship.org/uc/item/73t3b31t>

Authors

Brown, T.
Sabbi, G.-L.
Barnard, J.J.
[et al.](#)

Publication Date

2002-11-21

An Integrated Mechanical Design Concept for the Final Focusing Region for the HIF Point Design

T. Brown³, G-L Sabbi¹, J. J. Barnard², P. Heitzenroeder³, J. Chun³, J. Schmidt³, S. S. Yu¹, P. F. Peterson⁴, R. P. Abbott⁴, D. A. Callahan², J. F. Latkowski², B. G. Logan¹, W. R. Meier², S. J. Pemberton⁴, D. V. Rose⁵, W. M. Sharp², D. R. Welch⁵

1. Lawrence Berkeley National Laboratory; 2. Lawrence Livermore National Laboratory; 3. Princeton Plasma Physics Laboratory; 4. University of California, Berkeley; 5. Mission Research Corporation

Abstract-- A design study was undertaken to develop a "first cut" integrated mechanical design concept of the final focusing region for a conceptual IFE power plant that considers the major issues which must be addressed in an integrated driver and chamber system. The conceptual design in this study requires a total of 120 beamlines located in two conical arrays attached on the sides of the target chamber 180 degrees apart. Each beamline consists of four large-aperture superconducting quadrupole magnets and a dipole magnet. The major interface issues include radiation shielding and thermal insulation of the superconducting magnets; reaction of electromagnetic loads between the quadrupoles; alignment of the magnets; isolation of the vacuum regions in the target chamber from the beamline, and assembly and maintenance.

I. INTRODUCTION

The design configuration that was initiated in June of 2002 has evolved in a design based on the RPD-2002 [1] point design parameters. Since this was the first attempt in developing an integrated design of a heavy-ion fusion power plant, the study emphasizes the top level configuration issues which have an impact on the general arrangement. As the design evolved, areas were identified where further optimizations and improvements can be made and incorporated in future iterations of the RPD design. Papers in these proceedings [2-5] provide additional details on this work.

The proposed design of a heavy ion fusion power plant is

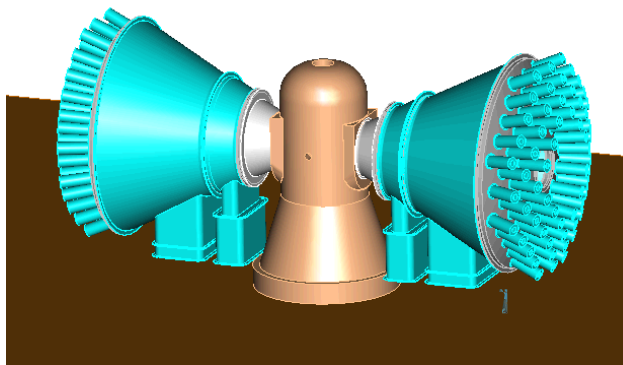

Fig. 1. An isometric view illustrating the configuration arrangement of the Robust Point Design (RPD-2002) for a Heavy Ion Power Plant

illustrated in Figure 1 showing a set of final focus magnets connecting on two sides of the target chamber.

II. MAGNET DETAILS

Table 1 summarizes the accelerator and final focus array parameters of the RPD-2002 design. The target requirements are met with a 120-beam accelerator providing a total of 7.0 MJ to the target. Each beam line has a set of four large-aperture magnets which make up the final magnet array preceded by a set of six to eight matching magnets which acts as a transition between the "matched beam"

TABLE 1
ACCELERATOR AND FINAL FOCUS ARRAY PARAMETERS

Parameter	Value
Accelerator	
Number of beams	120
Ion species-A	Bi-209
Ion energy - foot pulse	3.3 GeV
No. of foot pulse beams	48
Ion energy - main pulse	4.0 GeV
No. of main pulse beams	72
Final Focus Array	
Maximum array angle	24°
Beam half angle	10 mrad
Chamber array size	9x9
Angle between array rows	5.4°
Illumination	2-sided
Dist. to end of first magnet	6 m

configuration at the end of the drift compression section and the "large beam" configuration as the beam passes through the four final focus magnets. The details of the matching magnets are not developed or shown in the current RPD design. Figure 2 shows the magnet set on a single beamline and an expanded view illustrating some of the details of first quadrupole magnet. A shell-type (\cos^2) configuration is presently assumed with the coil mechanical pre-stress and

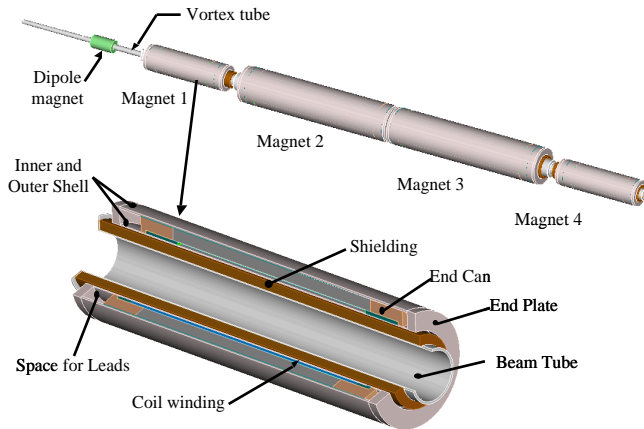

Fig 2. Final focus magnet system array

support provided by thick laminated stainless steel collars. Space limitations prevent the use of a support structure based on iron yoke and outer aluminum shell, a design approach generally adopted in high field Nb_3Sn accelerator magnets to take advantage of thermal contraction differentials between the structural elements. The superconducting magnets are enclosed in an inner and outer shell that is welded to end plates, forming an enclosed cold mass structure. End cans provide radial support and azimuthal compression of the coils ends. The approach taken in defining the magnet configuration was patterned off the LHC inner triplet quadrupole magnets [6]. Space is provided at one end for extracting the coil leads. Spacing between magnets will allow leads to be taken out between magnets 1 and 2 and between magnets 3 and 4. A beam tube is located inside the cold mass structure surrounded by radiation shielding and cryogenic thermal insulation. Table 2 provides a breakdown of the radial build dimensions that make up magnet 1 and typify the build of the remaining magnets except for changes in the thickness of the winding and coil support shell.

Target requirements set the maximum array angle at 24 degrees resulting in the angle subtended by each beamline viewed from the target to be 5.4 degrees. The magnetic field strengths of the superconducting windings must remain below approximately 7 T in the last focusing quadrupole to permit NbTi (with its favorable room-temperature annealing characteristics relative to Nb_3Sn) to be used in the magnet. This requires magnetic field strengths at the aperture to be less than approximately 4 T. Drift lengths between magnets that lie within different cryostats must be sufficient to allow for the ends of the windings and the cryostats to fit longitudinally along the beamline. Drift lengths for magnets lying within the same cryostat must be long enough so that leakage of magnetic field from one magnet to the next is not significant. The criteria chosen for this study is that the drift space between magnets must be 2.5 times the aperture radius (which is approximately 50 cm between the second and third magnet in this design).

The final four magnets are the most constrained, being closely packed into a transverse array, where flux sharing between transversely adjacent magnets will occur. The same field strength is used for all magnets in a given longitudinal position.

The total pulse is comprised of several subpulses referred to as blocks (A through E, see Table 2 in Ref. [2]) that operate at different energies and range of perveances. The matching section quadrupole strengths are different for Block A and Block E even though the perveances are nearly identical, because of the difference in beam energy for foot and main pulses. Respective beam envelopes for Block A and E are shown in Figure 3. Block B and C have lower perveances than Block A but can use the same quad strengths as Block A as long as the beam envelopes are scaled down proportional to $Q^{1/2}$ where Q is the perveance. The same relationship holds for Blocks E and D.

Tables 3, 4 and 5 list the magnet and conductor parameters for the final four quad magnets which have been developed to meet the requirements for field gradient, aperture size and number of channels in a high radiation environment. The design focus was placed on magnet 1 and 2, since magnet 3 and 4 have similar parameters to magnet 2 and 1, respectively, and benefit from better space availability. Consideration has been given to both NbTi and Nb_3Sn conductor material. Using NbTi conductor in magnet 1 allows improvement of the coil lifetime under heavy radiation load. However, Nb_3Sn would allow a higher field and temperature margin, and is required for magnet 2 based on peak field and operating temperature considerations. Use of Nb_3Sn in magnet 2 results in good critical current margin, but the very large stored energy and associated Lorentz forces

TABLE 2

MAGNET 1 BUILD DIMENSIONS

COMPONENT DETAILS	R (cm)	dR (cm)
Bore inner radius	12.0	
Pipe and water coolant space		0.5
Shielding inner radius	12.5	
Shield thickness		5.0
Gap		0.5
Cold mass	18.0	
Microcrystalline reflectors		0.5
LHe inner vessel		0.5
Winding inner radius	19.0	
Winding build		1.5
Winding outer radius	20.5	
Ground wrap		0.2
Coil support shell (Collar)		6.0
Slip plane		0.1
Outer shell thickness		1.0
Coil support structure outer radius	27.8	

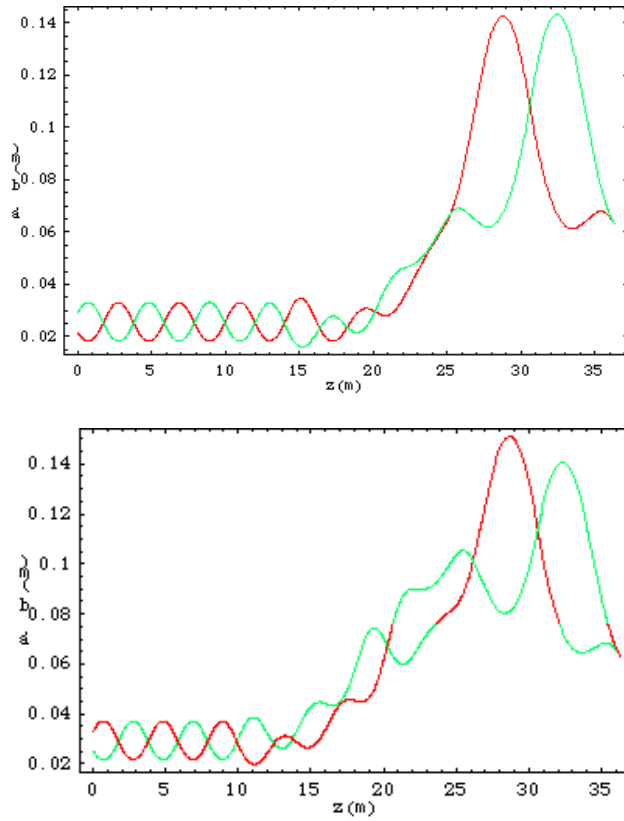

Fig. 3. x - and y - envelopes for the Block A (4.38 TW foot pulse, upper figure) and Block E (7.70 TW main pulse, lower figure) beams, in the final focus system. The target is 6.6 m to right of the final point in the figures (at $z = 42.9$ in the figure.)

require careful design of the mechanical support structure and quench protection system. Details of this design have yet to be worked out.

Magnetic coupling between magnets in adjacent arrays results in large forces and require an intermagnet supporting structure between magnet arrays involving magnets 1, 2 and much of magnet 3. It is expected that inter-magnet supporting structure will not be required for magnet 4. Figure 4 illustrates the intermagnet support concept developed for RPD-2002. Since the magnets need to be arranged in a conic array, the intermagnet support structure was designed to conform to the conic arrangement and provide for coil positioning and support using a series of stacked steel plates. The support plates would be made from steel castings that would be locally machined to provide positional tolerance. Individual plates would be mechanically attached to one another. The intermagnet structure is contoured to minimize the total weight of the structure but still provides the necessary shielding.

III. CRYOSTAT ARRANGEMENT

Because of the strong forces between magnets and the lack of space between beam arrays, a common cryostat concept is used to house the quadrupole coils and intermagnet cold mass structure.

A series of large conical vacuum dewars that enclose an array of quadrupole magnets attach to the target chamber.

TABLE 3

PARAMETERS OF THE FINAL FOCUS QUADRUPOLE MAGNETS

quad ¹	B'(T/m)	B(r _p)(T)	r _p (cm)	l(m)	ldrift ² (m)
1st	21.8	2.61	12	1.33	6.33
2nd	-19.1	-3.6	18.9	3	1.1
3rd	19.1	3.74	19.6	3	0.5
4th	-21.8	-2.99	13.7	1.33	1.1

1. 1st, 2nd, ... refers to longitudinal position relative to the chamber. So the 1st magnet is actually the final magnet, 2nd is next-to-last, etc.
2. ldrift is the beam drift distance after the hard edge of the indicated quadrupole magnet

TABLE 4

MAGNET PARAMETERS

Parameter	Symbol	Units	Magnet 1	Magnet 2
Operating	G _{op}	T/m	21.8	19.1
Coil aperture	R _{ic}	cm	19	25.9
Current/octan	I _{oct}	MA	0.61	1.02
Operating	T _{op}	K	4.35	4.5
Energy/chann	U _{op}	MJ/m	0.8	2.3
Operating	I _{op}	kA	15.6	20
Cu current	(J _{cu}) _{op}	kA/mm ²	1	0.45
Lorentz stress	J _{ss} ^{max}	MPa	73	70
Coil peak	B _{ss} ^{pk}	T	6.8	7.8
Short sample	G _{ss}	T/m	24.1	28.6

TABLE 5

CONDUCTOR, CABLE AND COIL PARAMETERS

Parameter	Units	Magnet 1	Magnet 2
Conductor		NbTi	Nb ₃ Sn
Strand diameter	mm	1.3	1.3
Number of strands		24	47
Cu/Sc ratio		1	3
Cable width (bare)	mm	15	29.6
Cable mid-thickness	mm	2.34	2.34
Keystone angle	deg	0.83	0.59
Insulation thickness	mm	0.1	0.2
Number of		39	51
Number of layers		1	1

This provides the necessary vacuum for the cryogenic structure and simplifies the vacuum connection between the beamlines and the target chamber.

Figure 5 shows the conical cryostat structure designed to house the array of magnet 1 assemblies. Space between magnet 1 and magnet 2 assemblies allows the design of individual cryostats to house the magnet 1 assembly in one cryostat structure and a second cryostat designed to house

IV. FOLLOW-UP OPTIMIZATION EFFORTS

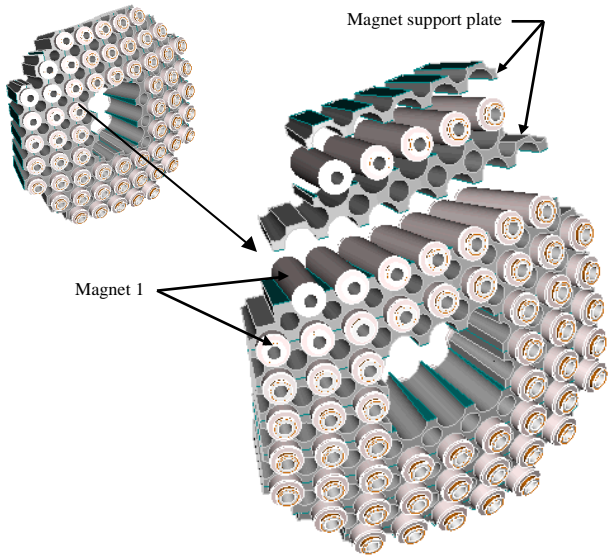

Fig. 4. Magnet System support and assembly concept

magnet 2 and 3 assemblies. The cryostats are extended at the bottom to form an opening for the gravity support structure; the supports also accommodate the transition from cryogenic to room temperature. Holes located in shell structures at the ends allow the beam tubes to extend slightly. The beam tubes are aligned and supported by the end shell structure in areas where there is a transition between the insulation surrounding the superconducting quadrupole magnet and the insulation system located on the inside of the cryostat. The exploded view shown in Figure 6 illustrates the details of the cryostat structures and magnet systems. A side view shown in Figure 7 is used to further identify the modular breakdown of the vortex tube assembly and final focus magnets. Each of the magnet cryostat assemblies can be constructed, operated and tested as a single unit prior to being brought together as a complete assembly. This arrangement can be used to enhance the assembly and maintenance.

Beam tubes are supported at two positions, one between the magnet 1 cryostat and magnet 2 - 3 cryostat. The transition for gravity support structure. The beam tubes are supported by the end shell structure in areas where there is a transition between the insulation surrounding the superconducting quadrupole magnet and the insulation system located on the inside of the cryostat. The beam tubes are aligned and supported by the end shell structure in areas where there is a transition between the insulation surrounding the superconducting quadrupole magnet and the insulation system located on the inside of the cryostat. The beam tubes are aligned and supported by the end shell structure in areas where there is a transition between the insulation surrounding the superconducting quadrupole magnet and the insulation system located on the inside of the cryostat.

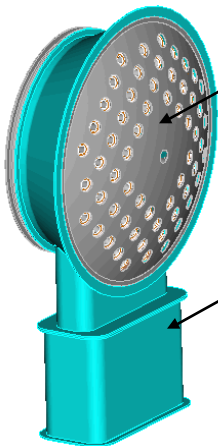

Fig. 5. Magnet 1 Cryostat Assembly

The baseline magnet layout uses shell-type coils aligned with the beam axis. This choice allows a modular approach with equally spaced beams, but the design space available for coils and support structure is limited at the forward (chamber-facing) end of the magnet. The flux sharing among neighboring channels also varies along the magnet length. As a result, the gradient is not constant along the length and the design becomes less efficient. Field errors are generated, since the coil optimization depends on distance between neighbors and each coil must be individually supported, leading to the choice of a shell-type layout with supporting collars and a single cryostat for the entire array. A possible alternative strategy is to use clusters of closely packed beams (typically 3x3) with small inter-beam convergence angle. Each cluster is focused by a sub-array of quadrupoles with coils parallel to each other, with the central quad aligned to the central beam axis and the adjacent beams going through their respective channels at an angle. This scheme enables the beam axes in each cluster to be closer to each other allowing one to consider using simpler racetrack coils with a common support structure and a separate cryostat for each sub-array. Each sub-array can be magnetically decoupled from the others by a flux-return iron yoke. The available beam aperture can accommodate beams traveling at an angle of a few mrad with respect to the magnetic axis, by cutting the inner radiation shields parallel to the beam axes. The related beam transport issues need to be evaluated but somewhat similar final focus configurations have been adopted in other accelerators.

With present parameters, magnet 1 operates at 90% of the maximum (conductor limited or “short sample”) gradient. An increase of the design margin from 10% to 20% should be pursued. This can be achieved by increasing the magnet

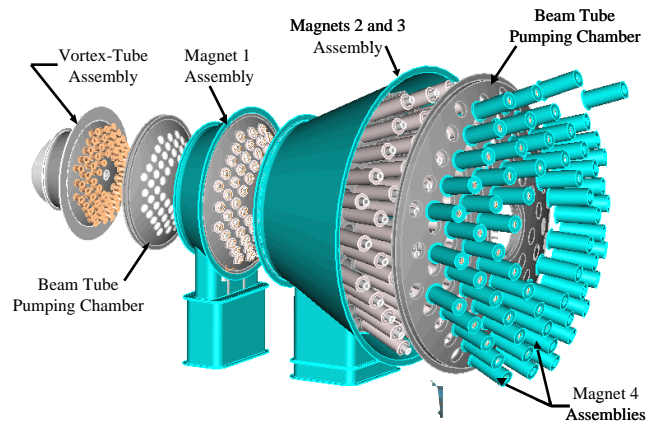

Fig.6. Exploded View of the Final Focusing Magnets

length and/or the cable thickness, or by replacing NbTi with Nb₃Sn. For magnet 2, the development of large diameter Nb₃Sn strand (with respect to present values of 0.8-1 mm) is necessary to decrease the number of turns and the magnet inductance.

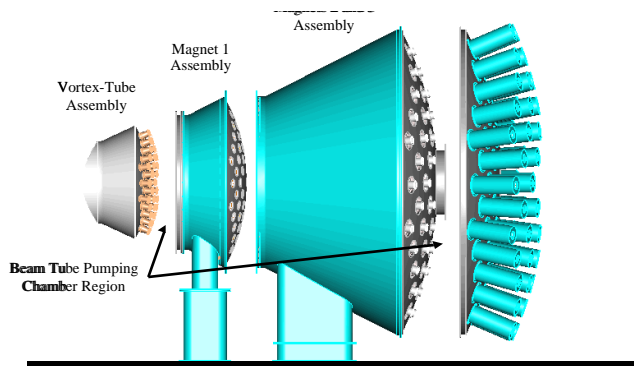

Fig. 7. Modular Breakdown of Final Focus Magnets

V. CONCLUDING REMARKS

The RPD-2002 configuration is in its early stage of development with further design details, machine options and system trade-offs to be investigated and incorporated. One reason for developing an integrated design of a heavy-ion fusion power plant was to identify the engineering areas that require further definition and refinement in future design studies. The 120-beam, 24-degree target requirement set the stage for developing a large structure. Details of the machine support and alignment concepts for beam tubes embedded in a cryogenically cooled structure need to be further developed. The reference configuration offers promise for this to occur but there may be better arrangements that may be superior, such as the horizontally aligned beam cluster approach discussed in Section IV. Refinements in system studies also can be used to possibly uncover more compact arrangements. Assembly and remote maintenance activities need to be developed in some detail to help optimize the design. The current configuration assumes that a complete focus magnet section is replaced if maintenance is required, however since the focus magnets are configured in modules, replacing subsections may be possible. The details of the matching magnets will affect the assembly process; consequently their integration into the RPD-2002 design will be needed in formulating a complete assembly and maintenance philosophy.

REFERENCES

- [1] S. Yu, et al., "A Robust Point Design for a Heavy Ion Fusion Power Plant", submitted to Fusion Science and Technology (2002).
- [2] W. Meier, et al, "Updated Point Design for HIF", ANS TOFE Meeting, November 18, these proceedings.
- [3] J. F. Latkowski, W. R. Meier, "Shielding of the Final Focusing System in the HIF Point Design," these proceedings
- [4] S. Pemberton, R. Abbott, P. F. Peterson, "Thick-Liquid Blanket Configuration and Response for the HIF Point Design," these proceedings.
- [5] C. Debonnel, G. Fukuda, P. Peterson, "X-Ray Ablation and Debris Venting for the HIF Point Design," these proceedings.
- [6] N. Andreev et al, "Mechanical Design and Analysis of LHC Inner Triplet Quadrupole Magnets at Fermilab", MT16 Proceedings , 1999, in press