

Lawrence Berkeley National Laboratory

Recent Work

Title

A REVIEW OF HIGH-TEMPERATURE ROTATING-PLASMA EXPERIMENTS

Permalink

<https://escholarship.org/uc/item/72z550s4>

Author

Wilcox, John M.

Publication Date

1959

UCRL 8584

UNIVERSITY OF
CALIFORNIA

*Radiation
Laboratory*

BERKELEY, CALIFORNIA

DISCLAIMER

This document was prepared as an account of work sponsored by the United States Government. While this document is believed to contain correct information, neither the United States Government nor any agency thereof, nor the Regents of the University of California, nor any of their employees, makes any warranty, express or implied, or assumes any legal responsibility for the accuracy, completeness, or usefulness of any information, apparatus, product, or process disclosed, or represents that its use would not infringe privately owned rights. Reference herein to any specific commercial product, process, or service by its trade name, trademark, manufacturer, or otherwise, does not necessarily constitute or imply its endorsement, recommendation, or favoring by the United States Government or any agency thereof, or the Regents of the University of California. The views and opinions of authors expressed herein do not necessarily state or reflect those of the United States Government or any agency thereof or the Regents of the University of California.

UCRL-8584

UNIVERSITY OF CALIFORNIA

Lawrence Radiation Laboratory
Berkeley, California

Contract No. W-7405-eng-48

A REVIEW OF HIGH-TEMPERATURE ROTATING-PLASMA EXPERIMENTS

John M. Wilcox

January 1959

Printed for the U.S. Atomic Energy Commission

A REVIEW OF HIGH-TEMPERATURE ROTATING-PLASMA EXPERIMENTS

John M. Wilcox

Lawrence Radiation Laboratory
University of California
Berkeley, California

January 1959

Abstract

By means of crossed electric and magnetic fields in a geometry having cylindrical symmetry, a charged particle can be induced to rotate about the axis of symmetry. The new degree of freedom associated with this rotation may offer new possibilities for containing and heating plasmas. This paper reviews four experimental approaches that are being actively investigated: the Berkeley Homopolar device, the Los Alamos Ixion, and the Berkeley and Moscow ion-magnetron experiments.

A REVIEW OF HIGH-TEMPERATURE ROTATING-PLASMA EXPERIMENTS

John M. Wilcox

Lawrence Radiation Laboratory
University of California
Berkeley, California

January 1959

The major experimental effort in the controlled thermonuclear reaction program has been based upon three different methods of plasma confinement—the pinch approach, the stellarator approach, and the magnetic-mirror approach.¹ Among the other approaches being investigated is the rotating-plasma system. By means of crossed electric and magnetic fields in a geometry having cylindrical symmetry, a charged particle can be induced to rotate about the axis of symmetry. The new degree of freedom associated with this rotation may offer new possibilities for containing and heating plasmas. Early work in this field was done at Oak Ridge.² We discuss here four experimental approaches that are being actively investigated: the Berkeley Homopolar device,³ the Los Alamos Ixion,⁴ and the Berkeley⁵ and Moscow⁶ ion-magnetron experiments.

Basic Concepts

We shall first discuss a few concepts which are important in these experiments, and then describe the four experiments individually. We will examine the electric drift velocity with the resulting diamagnetic current, the dielectric constant of a rotating plasma, the magnetic-mirror enhancement with a rotating plasma, and finally the possible formation of anode sheaths.

The well-known "electric drift velocity"⁷ is imparted to a charged particle in the presence of crossed electric and magnetic fields. For a singly charged particle we have

$$V_E = c \frac{\vec{E} \times \vec{B}}{B^2}, \quad (1)$$

or

$$V_E = 10^8 \frac{E}{B}, \quad (2)$$

where the electric drift velocity V_E is in cm/sec, the electric field E is in volts/cm, and the magnetic field B is in gauss. Thus, for example, in an electric field of 3 kv/cm and a magnetic field of 10 kilogauss, a deuteron will have a velocity of 3×10^7 cm/sec and thus an energy of 1 kv. We may note that the electric drift velocity is perpendicular to both the electric and magnetic fields, that it does not depend on the mass of the particle, and that it is in the same direction for positive and negative particles. Thus in an infinite plane geometry, ions and electrons have the same velocity and direction and there is no net electric current flow. However, in these experiments the presence of a radial electric field causes the particles to move with a radius of curvature R , and a centrifugal force term must be considered, so that the balance of forces on a particle is now

$$e(\vec{E} + \frac{1}{c} \vec{V}_D \times \vec{B}) + mV_D^2 \frac{\vec{R}}{R^2} = 0, \quad (3)$$

where \vec{R} is the radius vector of the particle position, m is the mass of the particle in question, e is the algebraic value of its charge, and c is the velocity of light. This leads to a drift velocity

$$\vec{V}_D = c \frac{\vec{E} \times \vec{B}}{B^2} - \frac{mcV_D^2}{e} \frac{\vec{B} \times \vec{R}}{B^2 R^2}. \quad (4)$$

Ions and electrons now move with different velocities, and an electric current \vec{j}_θ flows. Since the $\vec{j}_\theta \times \vec{B}$ force of the magnetic field is opposing the centrifugal force of the rotating particles, the plasma "leans" on the magnetic lines, and if the plasma rotational energy is sufficient the magnetic lines bow outward, thus weakening the field near the axis. The diamagnetic drift current density is

$$\vec{j}_\theta = \left(\frac{Ne}{c}\right) (\vec{V}_d - \vec{V}_e), \quad (5)$$

where N is the particle density (electrostatic forces will insure approximate equality of ion and electron densities), V_d is obtained from Eq. (3) applied to ions, and V_e is obtained from Eq. (3) applied to electrons. Since the centrifugal

force on the electrons is small compared with the centrifugal force on the ions, we have

$$\vec{j}_\theta \approx - (NMV_d^2) \frac{\vec{B} \times \vec{R}}{B^2 R^2}, \quad (6)$$

where M is the mass of the ions. Since $\vec{B} \times \vec{R}$ is in the same direction as the external solenoidal current that gives rise to \vec{B} , we note that indeed \vec{j}_θ is a diamagnetic current. For the case mentioned above with an outward electric field of 3 kv/cm and a magnetic field of 10 kilogauss, and with a deuteron density of $10^{14}/\text{cm}^3$ and a radius of curvature of 10 cm, the drift-current density is 34 amp/cm².

A plasma that is rotating in equilibrium with an applied electric field E can be compared with a condenser that is in equilibrium with an applied electric field; however, in the rotating plasma the energy is stored in the form of the kinetic energy of the moving particles. We can derive the dielectric constant K of the plasma by equating this kinetic-energy density to the increased energy density of the electric field:

$$\frac{kE^2}{8\pi} = \frac{E^2}{8\pi} + \frac{1}{2} \rho V E^2 = \frac{E^2}{8\pi} \left(1 + \frac{4\pi\rho c^2}{B^2} \right), \quad (7)$$

where ρ is the density of the plasma, and where use has been made of Eq. (2), so that the dielectric constant of the rotating plasma is

$$k = 1 + \frac{4\pi\rho c^2}{B^2}. \quad (8)$$

This number can be very large in a practical situation; for the case mentioned above the dielectric constant is 3.7×10^4 . Note that the effect of the displacement of the magnetic lines has not been included in this derivation.

Post has shown that under certain conditions a charged particle is reflected if it moves into a region of increasing magnetic field, so that particles can be contained if the magnetic field is made to increase at both ends.⁸ Post has shown that in order for a particle to pass through the mirror, we must have

$$W_{||}(c) \geq W_{\perp}(c) \left[\frac{B_m}{B_c} - 1 \right], \quad (9)$$

Where W_{\perp} and $W_{||}$ are the perpendicular and parallel kinetic energies, and c refers to the center and m to the mirror. If the plasma is rotating, the centrifugal force tends to keep the particles away from the axis, where they must go to escape, and thus the mirror containment efficiency is enhanced.³ An elegant theoretical treatment⁴ shows that for a rotating plasma the above inequality is to be replaced by

$$W_{||}(c) \geq W_{\perp}(c) \left[\frac{B_m}{B_c} - 1 \right] + \frac{1}{2} M V_E^2(c) \left[1 - \frac{B_c}{B_m} \right], \quad (10)$$

where M is the mass of the deuteron and V_E is given by Eq. (2). In this case W_{\perp} is to be measured in the rotating frame of reference. Thus a rotating plasma is more efficiently contained by the magnetic mirror.

Finally, we consider the possible formation of an anode sheath, for the case in which the anode surface is parallel to the magnetic field lines. In a conventional electron-discharge tube the sheath forms at the cathode, because of the high mobility of the electrons. However, for motion perpendicular to a magnetic field the ions have a greater mobility, while the electrons are tightly confined to their field lines. The ions acquire their electric drift energy by moving a short distance in a direction parallel to the electric field. As they move away from the surface of the anode a region with net negative space charge is left behind. In this narrow sheath a large voltage drop may be present. In some of the experiments the presence of the anode sheath is considered desirable, while in others it is avoided.

The Homopolar Experiment

In the Homopolar experiment the emphasis has been on the study of the basic properties of rotating plasmas, therefore argon has been used for the most part. In this experiment³ the object is to create a spinning disc of plasma which is somewhat similar to the flywheel of a conventional Homopolar generator. The experimental geometry is shown in Fig. 1. The vacuum chamber is placed

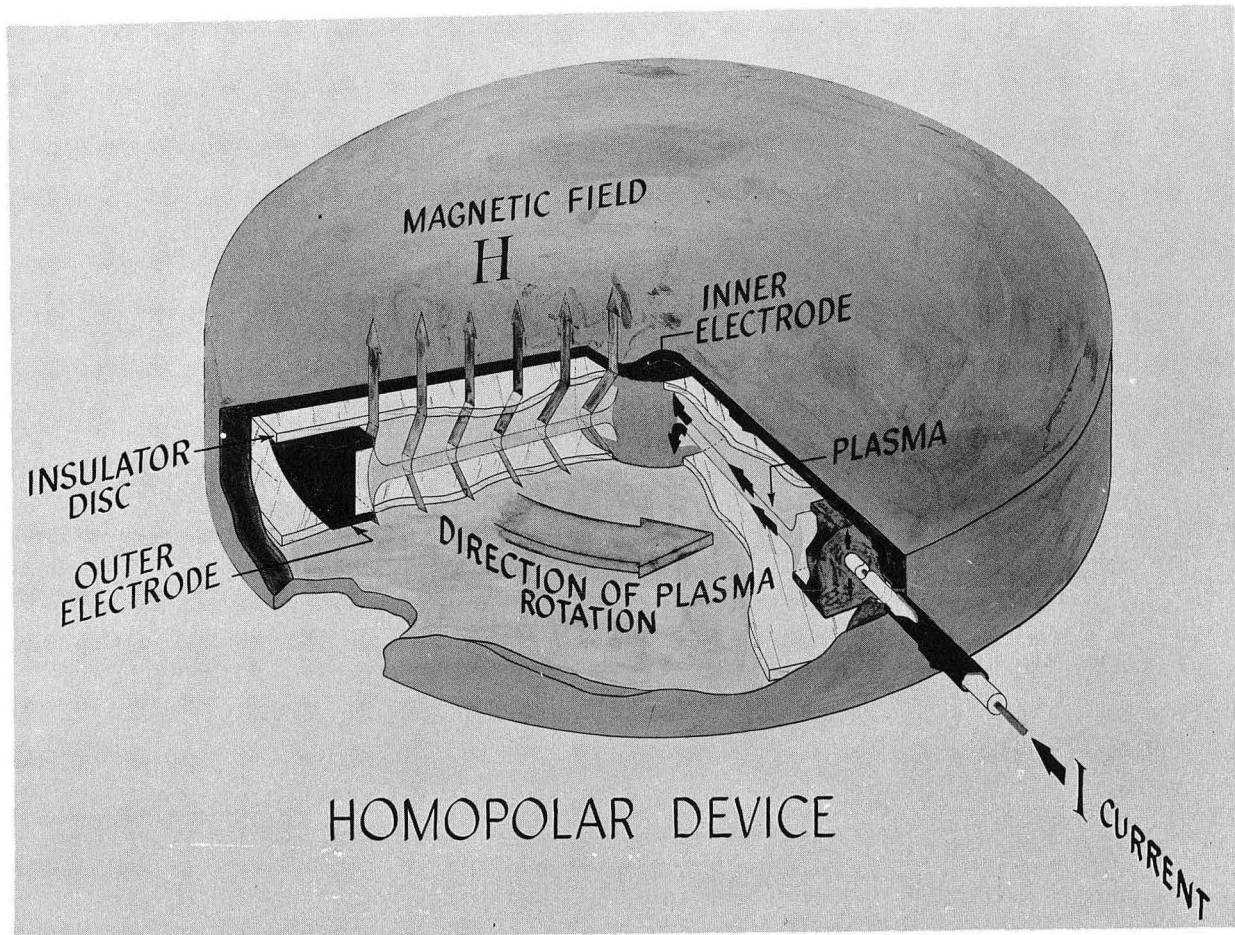

ZN-1857

Fig. 1. Diagram of Homopolar device.

between the pole tips of a magnet so that there is an axial magnetic field of up to 18,000 gauss. A radial electric field exists between the inner electrode and the concentric cylindrical outer electrode. By operation at a comparatively high gas pressure (~ 100 microns) the anode sheath effects are largely removed, so that the electric field exists through the body of the plasma, and the entire plasma is set spinning with the electric drift velocity v_D . Initially a large pulse of current is required to ionize the gas and supply the energy of rotation. Once the plasma has been set in rotation a much smaller current will be drawn, due only to the viscous drag of the plasma. In Fig. 2 the heavy trace shows the behavior of the voltage, while the positive light trace, which extends from 0 to 6 microseconds, is the charging-current pulse. The negative current pulses are discussed below.

The equivalent circuit of the Homopolar experiment is shown in Fig. 3. Thus the spinning plasma is represented by a capacitance C_H , which arises from the dielectric effect discussed above, with a parallel resistance R_L , which represents viscous effects. Indeed this geometry may have application as a very-low-inductance capacitor for driving controlled-fusion experiments.⁹

Plasma rotation has been demonstrated by three observations. If we consider the rotating Homopolar as a charged capacitance, then it should be possible to recover the initial charge that was fed in by the pulse of charging current. For this purpose the terminals of the Homopolar are rapidly shorted with the crowbar circuit shown in Fig. 3. The resulting current pulse is in the opposite direction to the charging current, and resembles one of the negative traces shown in Fig. 2. By application of the crowbar at various times, the amount of energy still stored in the system after any interval can be measured. The dissipation of stored energy is indicated by the decreased crowbar current traces at longer times. The crowbar method has shown that under favorable conditions more than half of the input energy can be recovered.

Plasma rotation can also be observed by the Doppler shift of the emitted radiation, as shown in Fig. 4. A spectrometer views the rotating plasma through a tangential port. If the direction of the magnetic field is reversed, then, according to Eq. (1), the direction of rotation will be reversed. The rotational velocities calculated from the Doppler shift agree with the velocities calculated from the crowbar current. Rotational energies of a few hundred electron volts are measured during operation with argon.

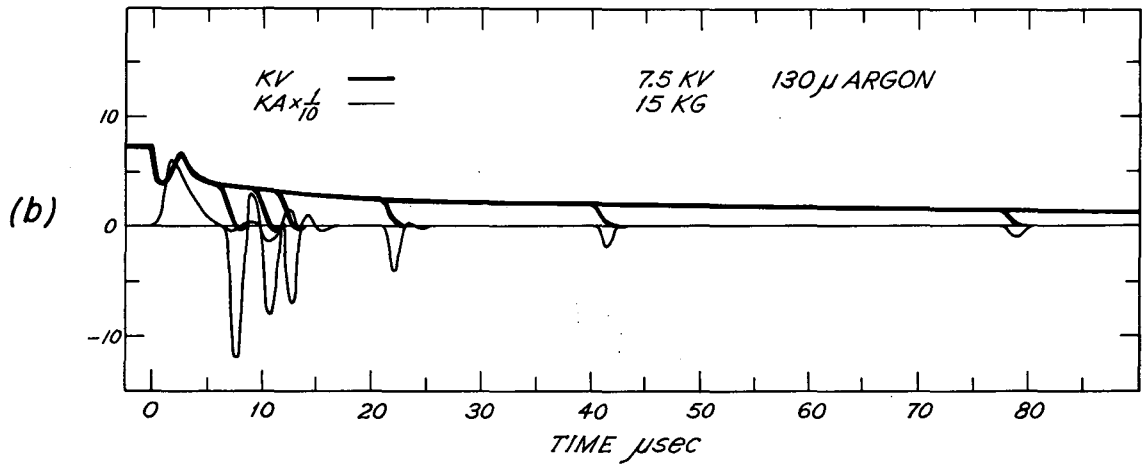

MU-14551

Fig. 2. Current and voltage wave forms in the Homopolar device.

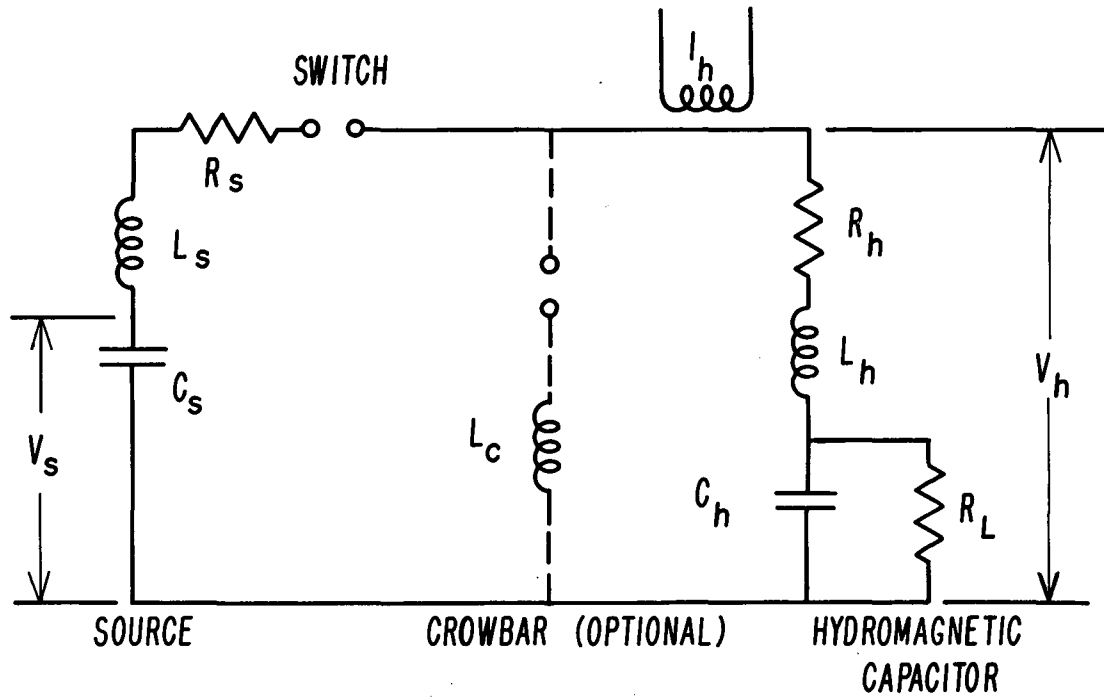

MU-14546

Fig. 3. Equivalent circuit of Homopolar device.

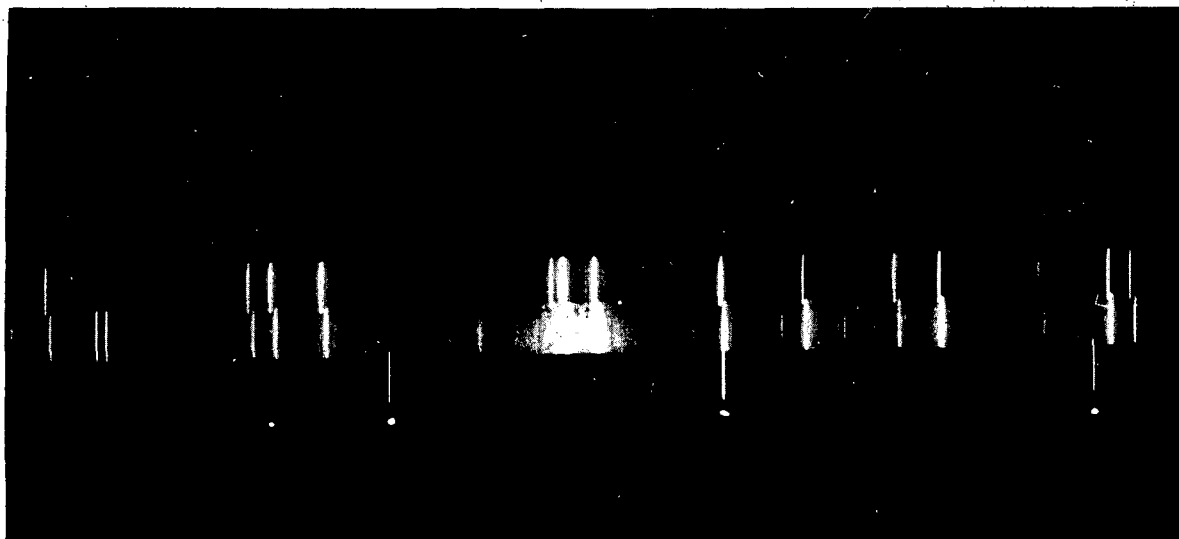

ZN-1858

Fig. 4. Doppler-shifted spectra from Homopolar device.

A third observation of plasma rotation is the "spin loop" data. As shown above, the centrifugal force from the plasma rotation gives rise to a diamagnetic current in the θ direction, and thus to a radial component of magnetic field. We may think of the rotating particles as "leaning" on the magnetic lines and bending them outward. This effect is independent of the direction of rotation. Thus the signal in a magnetic probe coil which is oriented to detect H_r should be independent of the sense of rotation. The observed spin-loop signal is shown in Fig. 5, and indeed has the same polarity for both directions of rotation. A slight misalignment of the pickup coil is believed to account for the difference in amplitude between the two signals.

Thus a considerable storage of rotating energy has been demonstrated in the Homopolar experiment in a geometry which is stable for times of the order of $100\mu\text{sec}$. For controlled-fusion applications some of this energy will have to be converted to random or heat energy, which can presumably be accomplished with suitable perturbations in the electric or magnetic fields.

The same basic ideas have been incorporated in the improved geometry shown in Fig. 6. In this case the centrifugal force will be more effective in pulling the plasma away from the insulators. Experiments are just beginning with this geometry; however, a decay time of several hundred microseconds has been observed.

Ixion

This experiment is named for the king in Greek mythology who aspired to the love of a goddess and was therefore sentenced to be forever bound to a flaming rotating wheel. The Ixion⁴ geometry as shown in Fig. 7 is long (86 cm) in comparison with the flat-disc geometry of the Homopolar. The pulsed magnetic field increases from 9 kilogauss at the median plane to 20 kilogauss at the mirror throat, and the pressure between pulses is 2×10^{-6} mm Hg. The first experiments were done with metallic central electrodes, but the latest model has a plasma "center rod." A puff of deuterium gas corresponding to one micron pressure in the apparatus is ionized and driven into the machine by a magnetic shock coil. This plasma electrode makes electrical contact with a pair of tungsten ring electrodes located at the mirror throats. After the plasma

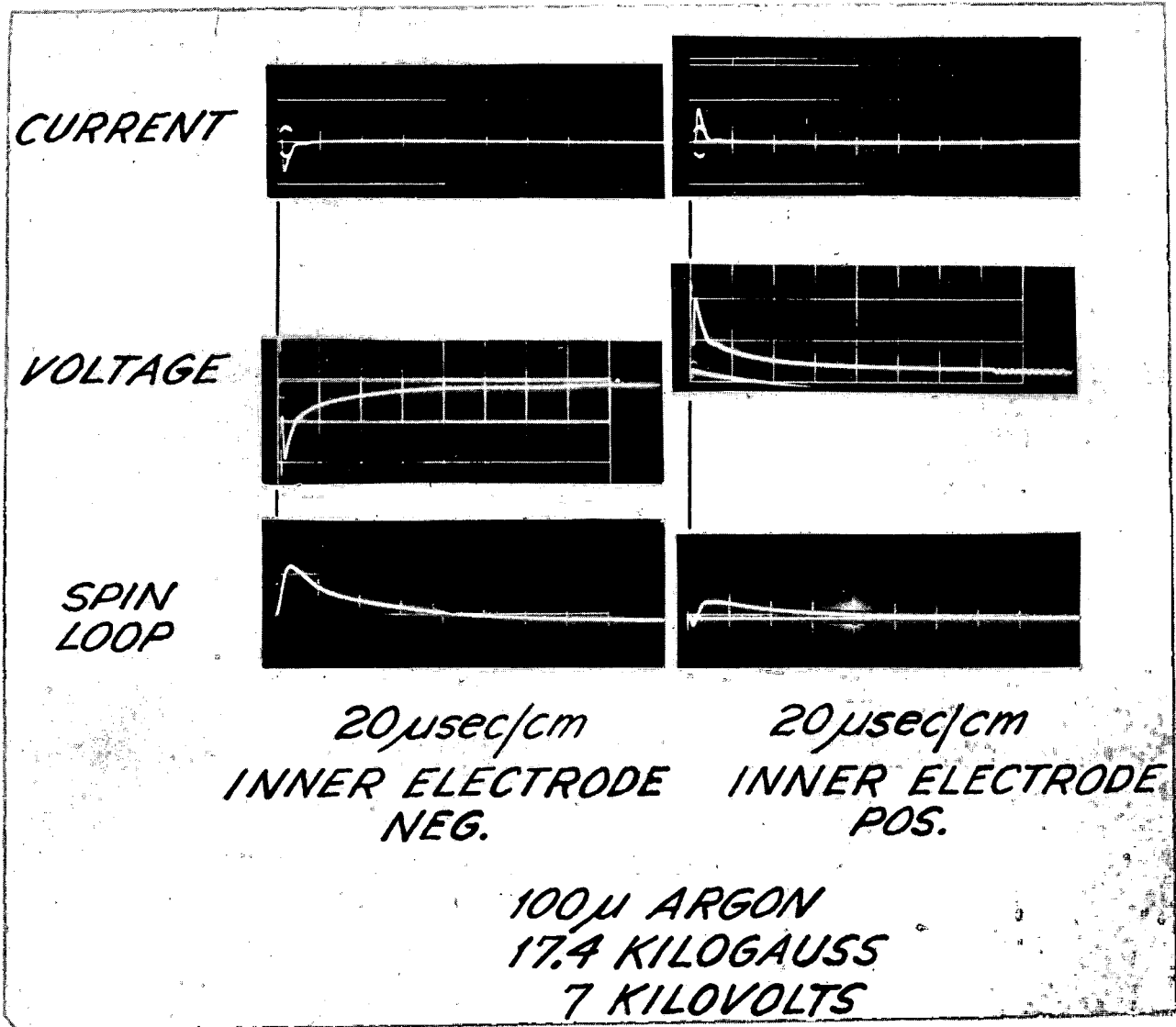

ZN-1856

Fig. 5. Spin-loop signal from Homopolar device.

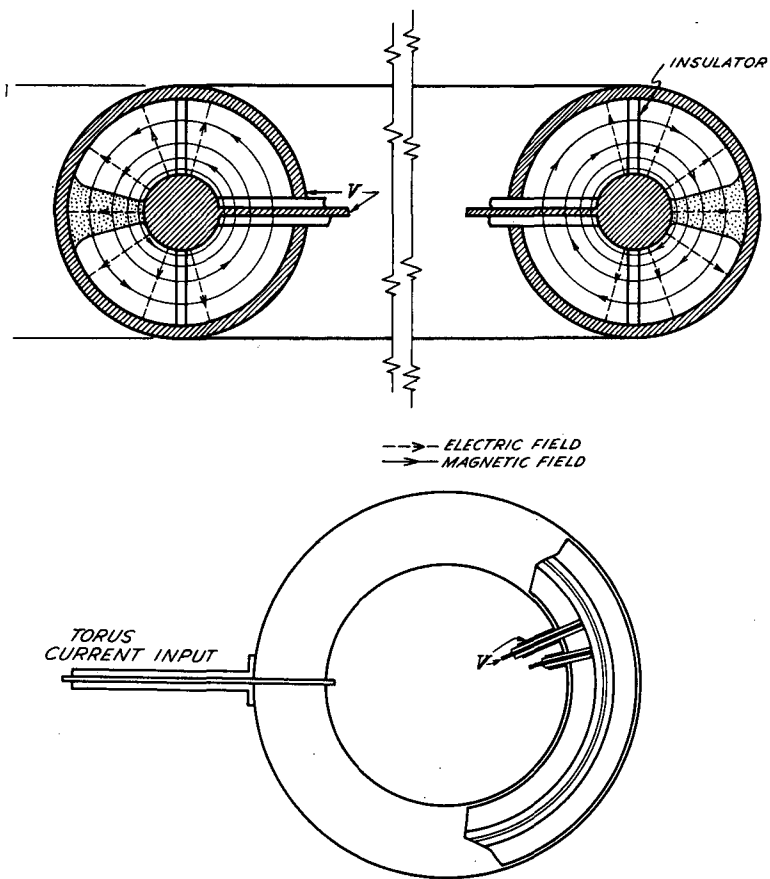

Fig. 6. Later version of Homopolar device.

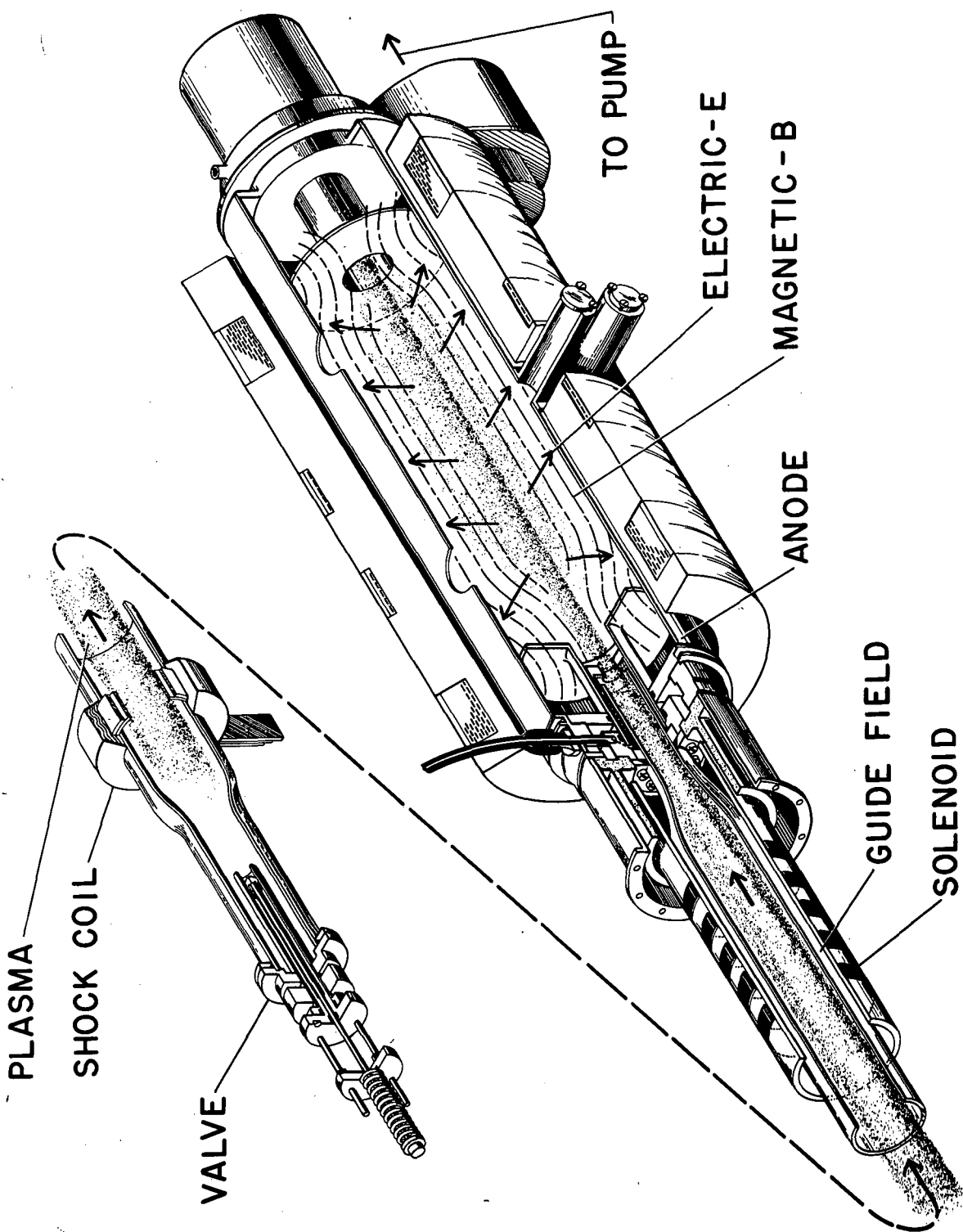

Fig. 7. Diagram of Ixion.

electrode has arrived the high voltage (10 kv) is pulsed on. For about 200 μ sec negligible current is drawn, and then a sudden impulse of current of about 20,000 amp is drawn for 25 μ sec, as shown in Figs. 8A and 8B, which have a sweep speed of 200 μ sec/cm. The voltage falls to about one-half its original value as the discharge occurs, and then decays to zero in about 500 μ sec. This current spike and the voltage behavior are interpreted as being caused by the development of a rotating plasma. The subsequent decay of the voltage is attributed to the loss of plasma to the walls.

Plasma rotation has been demonstrated by the crowbar technique and by Doppler-shift observations. When Ixion is short-circuited about one-fifth of the original charge can be recovered. In the Homopolar experiment one-half the original charge was recovered, but this was with operation with argon, and these machines are found experimentally to operate better with heavy gases than with deuterium. The capacitance of Ixion can be calculated from the plasma dielectric constant (given in Eq. (8)) increased by a factor of the order of 1.5, which corrects for the diamagnetic weakening of the applied magnetic field. Using this capacitance and the observed amount of charge that can be recovered, one can compute that the rotating deuterium plasma would have an equivalent pressure of 5.6 microns. The pressure of the injected deuterium is 1.5 microns; the discrepancy may be accounted for by the presence of impurities or by an error in the geometrical correction.

The Doppler shift that occurs when the magnetic field is reversed is shown in Fig. 8D, which is a profile of a carbon line. The drift velocity of 4×10^6 cm/sec calculated herefrom is consistent with the value calculated from the applied electric and magnetic fields. The spectral analysis also shows many other impurity lines during the current pulse, and H and D lines lasting for 100 μ sec after the current pulse.

The high-impedance delay for 200 μ sec after the voltage is pulsed on was examined with an earlier model having a metallic central electrode. By electrostatic probing it was found that most of the voltage drop occurred just outside the anode, corresponding to the presence of an electron sheath as discussed above. Thus it is seen that the electric field does not penetrate the main body of the plasma and bulk rotation does not occur.

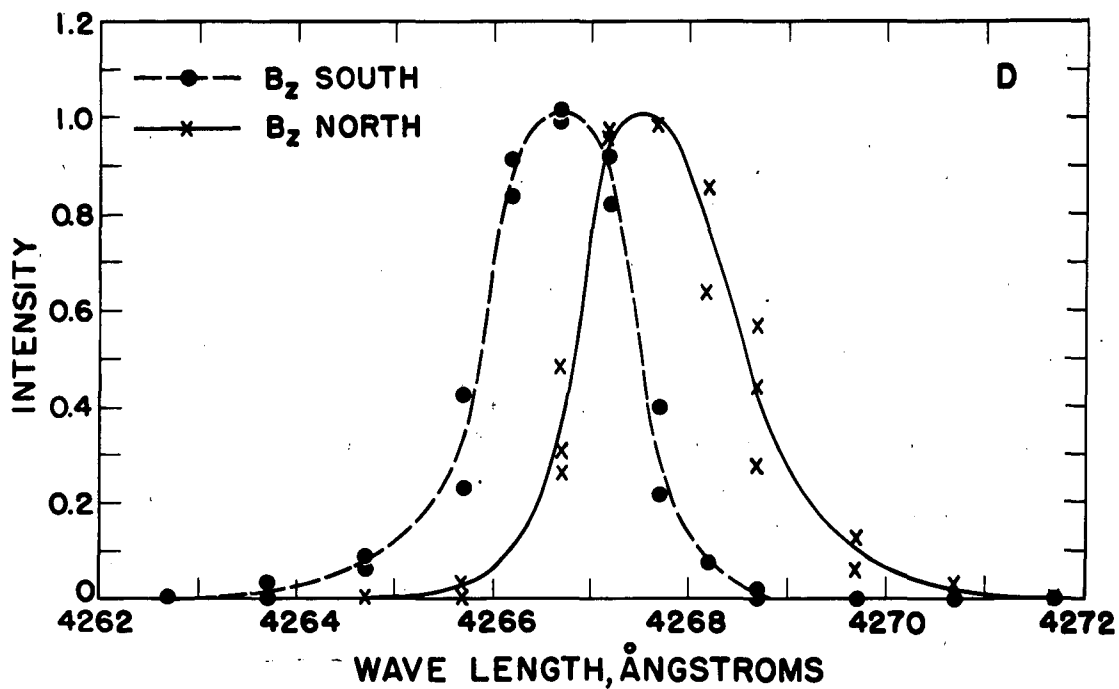
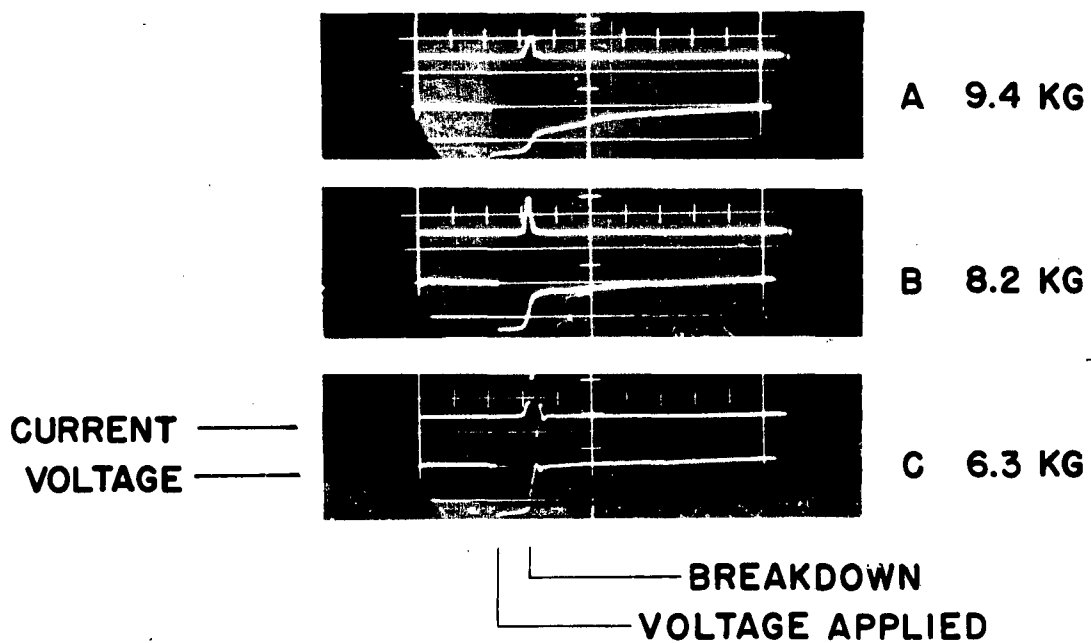

Fig. 8. Experimental data from Ixion.

If the magnetic field is lowered, the voltage raised, or the pressure raised excessively the discharge is oscillatory, as shown in Fig. 8C. The voltage falls to zero almost at once. Neutrons occur during the current spike in this mode of operation, with about 10^5 neutrons per discharge at 40 kv and a detectable yield at 10 kv. If the magnetic field is increased so as to obtain the capacitive-type operation shown in Figs. 8A and 8B, the neutrons disappear. The origin of these neutrons has not been satisfactorily explained.

In an Ixion with a metal center rod, large diamagnetic signals were observed with a magnetic probe coil inside the center rod, during the oscillatory discharge of Fig. 8C. These signals corresponded to almost complete removal of the axial magnetic field from the center of the machine. The diamagnetic effect decreased to zero as the probe was moved away from the center plane to the mirror throat. Diamagnetic signals have also been observed on Ixion with the plasma center rod. The diamagnetic decrease for voltage-holding operation is of the order of 30% at the center, and decreases to zero at the mirror throat.

Berkeley Ion Magnetron

This experiment⁵ utilizes a long solenoidal magnetic field with mirror throats at both ends, together with a metal center electrode, as shown in Fig. 9. However, the philosophy on which this is based is quite different from that in the two preceding experiments. The tube is operated at the comparatively low pressure of a fraction of a micron, and thus the anode sheath develops about the central electrode. Since this sheath contains a considerable density of ionizing electrons circulating around the axis, a neutral deuterium molecule that enters the sheath volume has a good chance of being ionized. The ion thus formed will be rapidly accelerated out of the sheath by the electric field, and will circulate around the axis in magnetronlike orbits with a kinetic energy equal to the potential energy at the point in the sheath at which it was ionized. The magnetic field is considerably stronger than the magnetron cutoff value, so that the circulating ions cannot reach the outer wall. Each time the ion returns toward the axis it is reflected by the sheath potential; the sheath protects the central electrode. After several revolutions this fast ion undergoes a charge-exchange collision

which sends a fast neutral into the outer wall and leaves behind a thermal ion. This process limits the circulating current to a rather low value in the present experiments. In contrast to the two pulsed experiments described above, the ion magnetron operates under continuous conditions, with a magnetic field of 8 kilogauss at the center and 12 kilogauss at the mirror throats, and an applied voltage of 10 kv. The ion magnetron operates in a high-impedance mode which may be comparable to the 200- μ sec "waiting period" encountered in the operation of Ixion.

The first indication of the presence of sizable circulating ion currents came with the observation of rather violent oscillations of the center electrode. This electrode was mechanically supported at only one end, so that it was free to oscillate as a pendulum. This motion could be viewed through the quartz port shown in Fig. 9. Several exploratory experiments supported the view that the force responsible for these oscillations came from the recoil of ions accelerated in the sheath. From the magnitude of the forces involved the circulating current was estimated to be equivalent to about 100 amperes, when the current drawn by the tube was about 1 amp.

When the tube voltage is turned on, the behavior of the gauge pressure and tube current is as shown in Fig. 10. The size and duration of the initial current pulse can be computed by considering that the neutral gas initially present flows into the sheath with thermal velocity.

With steady operation at a tube voltage of 10 kv and a tube current of 1 amp, neutrons are produced at a rate of a few times 10^4 per second. They are probably produced by head-on collisions between ions entering the sheath and ions leaving the sheath. When the geometry shown in Fig. 9 was modified to include vacuum pumping at both ends of the tube, the neutron rate increased by an order of magnitude, since the circulating current was able to reach a higher value before being limited by charge exchange.

Moscow Ion Magnetron

This experiment⁶ also utilizes a solenoidal magnetic field with mirror throats on both ends. However, a dc plasma beam serves as the central electrode, which is positive at voltages up to 40 kilovolts, dc or pulsed.

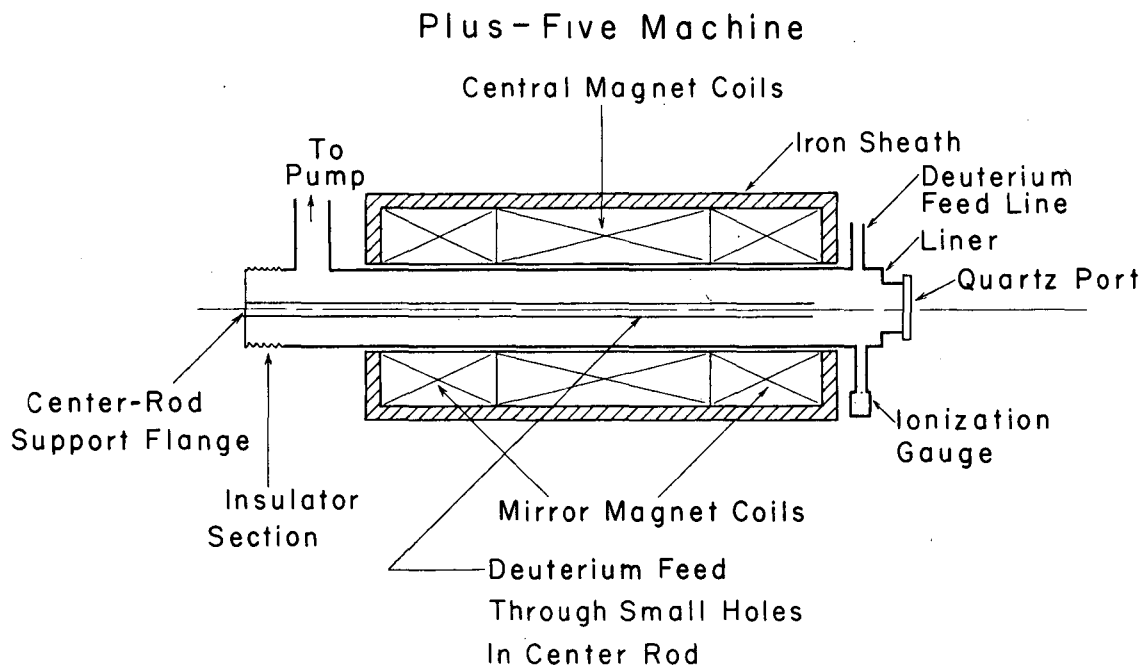

MU-16598

Fig. 9. Diagram of Berkeley ion magnetron.

1100-amp End Coils
1000-amp Center Coil
10 kilovolts
P = .35 μ

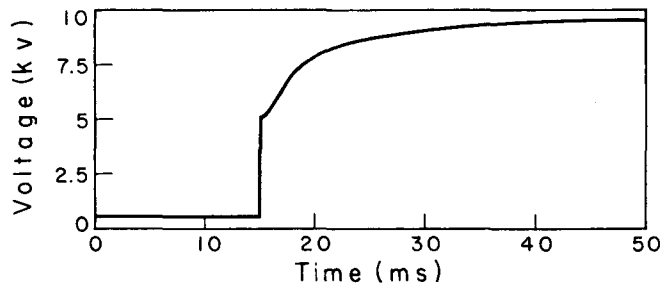
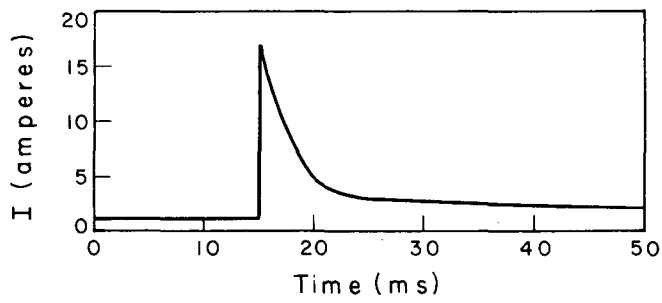
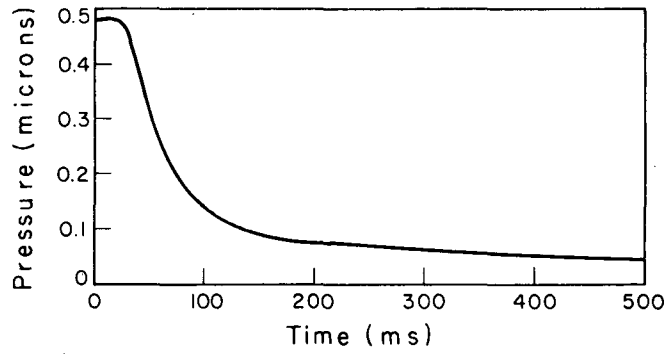

MU-16605

Fig. 10. Experimental data from Berkeley ion magnetron.

The vacuum chamber is 170 cm long and 50 cm in diameter, which makes it the largest among the experiments discussed here. The system geometry shown in Fig. 11 has been drawn from a sketch made by Dr. M.S. Yoffe. The central magnetic field is 8 kilogauss, rising to 12 kilogauss at the mirror throats. Oil diffusion pumps at the ends and evaporated-titanium pumps in the middle give a large vacuum-pumping rate and a base pressure of 10^{-7} mm Hg.

High-energy neutrals from the charge-exchange process previously mentioned are detected by secondary electron emission, as shown in Fig. 11. Neutron production is observed with a plastic phosphor viewed by a phototube. In one type of experiment the high voltage is pulsed on with a square wave for from 10 μ sec to 2 msec. At the end of the square wave the voltage is returned to ground in about 10^{-7} sec. The high-energy neutral-detector response decreases approximately exponentially with a lifetime of 1 or 2 msec, and neutron pulses are seen for a few msec after the voltage has gone to zero. Thus the decay time of the system appears to be 1 or 2 msec, somewhat longer than has been observed with the Homopolar or Ixion; however, the system dimensions are larger in this experiment, and the mode of operation is considerably different.

This ion magnetron makes 10^7 to 10^8 neutrons per second at 40 kilovolts, with a tube current of 1 or 2 amp. The curve for neutron yield vs. voltage follows the general shape of the D^+ cross section.

In an earlier smaller model, extensive measurements were made with hot and cold probes of the radial distribution of potential. Three modes of operation may be distinguished. If the applied voltage is very high, all the ions supplied by the plasma source are accelerated radially as soon as they leave the mouth of the plasma source, so that there is no central beam. As the applied voltage is reduced, a second mode of operation is reached in which the central beam reaches a considerable distance into the machine, but not all the way across. In this case a stable radial potential distribution is observed, and most of the electric field is concentrated in the vicinity of the axis, corresponding to the formation of the anode sheath discussed above. Finally, if the applied voltage is decreased still more, a mode of operation is attained in which the central plasma column reaches across the entire length of the machine. In this regime the radial potential distribution oscillates at frequencies of 200 to 400 kilocycles between a steep distribution which corresponds to the presence of an anode sheath and a sloping distribution which corresponds to the absence of a sheath voltage drop. It is not known at present

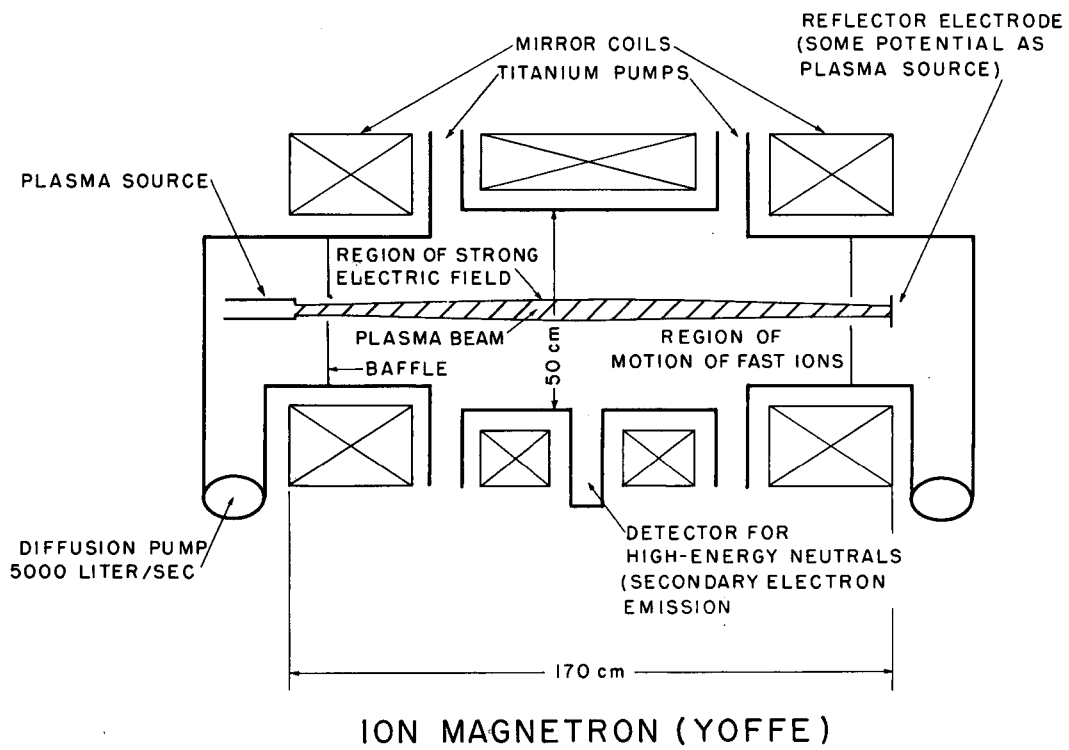

MU-16876

Fig. 11. Diagram of Moscow ion magnetron.

whether these oscillations can be avoided. Since a plasma central electrode offers many advantages, the question of its stability is an important one.

Summary

By emphasis of various aspects of the fundamental concepts of electric drift velocity, diamagnetic azimuthal current, dielectric constant of rotating plasma, magnetic mirror enhancement, and anode sheath formation the four experimental approaches have been developed. It is clear that this work has only begun to define the problems and possibilities of rotating plasmas. We hope that this article has pointed out some of the challenging experimental and theoretical problems that remain to be solved.

Acknowledgment

We wish to thank Lloyd Smith for a critical reading of the manuscript.

References

1. For a review of the United States' program see Amasa Bishop, The U.S. Program in Controlled Fusion (Addison-Wesley Publishing Co., Reading, Mass., 1958).
2. Ibid., p. 67.
3. Anderson, Baker, Bratenahl, Furth, Kunkel, and Stone, International Conference on Peaceful Uses of Atomic Energy, 2d, Geneva, 1958, paper No. 373; Anderson, Baker, Bratenahl, Furth, Ise, Kunkel, and Stone, Study and Use of Rotating Plasma, University of California Radiation Laboratory Report UCRL-8067, Dec. 1957.
4. Boyer, Hammel, Longmire, Nagle, Ribe, and Riesenfeld, International Conference on Peaceful Uses of Atomic Energy, 2d, Geneva, 1958, paper No. 2383.
5. J. Wilcox, J.D. Gow, and L. Smith, Bull. Am. Phys. Soc. Ser. II, 4, 55 (1959); The Ion Magnetron, University of California Radiation Laboratory Report UCRL-8579.
6. M.S. Yoffe, private communication; E.E. Yushmanov, Plasma Physics and the Problems of Controlled Thermonuclear Reactions, Vol. IV, p.235. (To be published in translation by Pergamon Press, Ltd.)
7. L. Spitzer, Physics of Fully Ionized Gases (Interscience Publishers, New York, 1956).
8. R.F. Post, Bull. Am. Phys. Soc. Ser. II, 3, 196 (1958); International Conference on Peaceful Uses of Atomic Energy, 2d, Geneva, 1958, paper No. 377.
9. Anderson, Baker, Bratenahl, Furth, and Kunkel, A Hydromagnetic Capacitor, J. Appl. Phys. 30, 188 (1959).

This report was prepared as an account of Government sponsored work. Neither the United States, nor the Commission, nor any person acting on behalf of the Commission:

- A. Makes any warranty or representation, expressed or implied, with respect to the accuracy, completeness, or usefulness of the information contained in this report, or that the use of any information, apparatus, method, or process disclosed in this report may not infringe privately owned rights; or
- B. Assumes any liabilities with respect to the use of, or for damages resulting from the use of any information, apparatus, method, or process disclosed in this report.

As used in the above, "person acting on behalf of the Commission" includes any employee or contractor of the Commission, or employee of such contractor, to the extent that such employee or contractor of the Commission, or employee of such contractor prepares, disseminates, or provides access to, any information pursuant to his employment or contract with the Commission, or his employment with such contractor.