

Lawrence Berkeley National Laboratory

Recent Work

Title

Realizing the DSM Potential of Integrated Envelope and Lighting Systems

Permalink

<https://escholarship.org/uc/item/72t035tw>

Authors

Selkowitz, S.E.

Lee, E.S.

Leader), F. Rubinstein (Interim Group
[et al.](#)

Publication Date

1993-10-01



Lawrence Berkeley Laboratory

UNIVERSITY OF CALIFORNIA

ENERGY & ENVIRONMENT DIVISION

Presented at the Second National New Construction Programs
for Demand-Side Management Conference, San Diego, CA,
October 24-27, 1993, and to be published in the Proceedings

Realizing the DSM Potential of Integrated Envelope and Lighting Systems

S.E. Selkowitz, E.S. Lee, F. Rubinstein, J.H. Klems,
K. Papamichael, L.O. Beltrán, D. DiBartolomeo, and R. Sullivan

October 1993

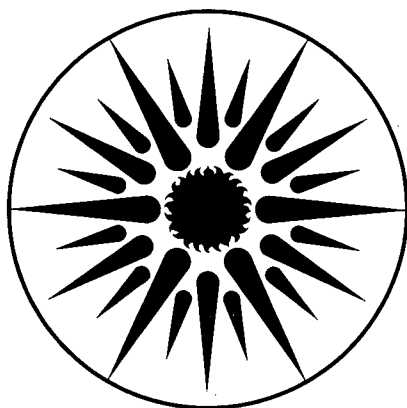

ENERGY & ENVIRONMENT
DIVISION

LOAN COPY
Circulates
for 4 weeks
Bldg. 50 Library.

LBL-34731

DISCLAIMER

This document was prepared as an account of work sponsored by the United States Government. While this document is believed to contain correct information, neither the United States Government nor any agency thereof, nor the Regents of the University of California, nor any of their employees, makes any warranty, express or implied, or assumes any legal responsibility for the accuracy, completeness, or usefulness of any information, apparatus, product, or process disclosed, or represents that its use would not infringe privately owned rights. Reference herein to any specific commercial product, process, or service by its trade name, trademark, manufacturer, or otherwise, does not necessarily constitute or imply its endorsement, recommendation, or favoring by the United States Government or any agency thereof, or the Regents of the University of California. The views and opinions of authors expressed herein do not necessarily state or reflect those of the United States Government or any agency thereof or the Regents of the University of California.

Presented at the Second National New Construction Programs for Demand-Side Management Conference, October 24-27, 1993 in San Diego, CA and published in the Proceedings.

REALIZING THE DSM POTENTIAL OF INTEGRATED ENVELOPE AND LIGHTING SYSTEMS

S.E. Selkowitz E.S. Lee F. Rubinstein J.H. Klems
K. Papamichael L.O. Beltrán D. DiBartolomeo R. Sullivan

Energy and Environment Division
Lawrence Berkeley Laboratory
University of California
Berkeley, CA

October 1993

This research was funded by the California Institute for Energy Efficiency (CIEE), a research unit of the University of California. Additional related support was provided by the Assistant Secretary for Energy Efficiency and Renewable Energy, Office of Building Technologies, Building Systems and Materials Division of the U.S. Department of Energy under Contract No. DE-AC03-76SF00098.

REALIZING THE DSM POTENTIAL OF INTEGRATED ENVELOPE AND LIGHTING SYSTEMS

S.E. Selkowitz E.S. Lee F. Rubinstein J.H. Klems
K. Papamichael L.O. Beltrán D. DiBartolomeo R. Sullivan

Building Technologies Program
Energy and Environment Division
Lawrence Berkeley Laboratory
University of California
Berkeley, CA

ABSTRACT

Most utility demand-side management (DSM) programs are designed to capture savings by substituting more efficient building components for less efficient products; for example, replace magnetic ballasts with electronic ballasts. Much larger savings can be captured at lower cost if a systems perspective is applied to the problem of capturing demand-side management potentials. We summarize work to date on the development, implementation, and demonstration of integrated envelope and lighting systems. Two envelope and lighting prototypes were developed through an iterative process of design and evaluation. By implementing the prototypes in reduced scale, practical issues of how to build and control the systems are being resolved. Field tests with scale models, currently in progress, are being used to determine daylighting and thermal performance in real-time under actual weather conditions. Demonstrations of the integrated systems either in part or as a whole system are being planned in parallel with several utility funded building programs to resolve real-world implementation under complex site, building, and cost constraints. Results of this second phase of research indicate that integrated systems offer solutions that not only achieve significant peak demand reductions but also realize consistent energy savings with added occupant comfort and satisfaction.

INTRODUCTION

Daylighting controls coupled with energy efficient lighting and glazing have the potential to significantly reduce peak demand and total electricity use in commercial buildings. In

California, projections indicate that by the year 2000, 500-800 MWh of total electricity can be saved over business-as-usual practice for new construction and partial retrofit of office buildings alone (Figure 1). Peak demand using new glazing and lighting technologies can be reduced by 30-35% (Sullivan et al. 1992a). Economic benefits include reduced energy bills as well as the potential for lower capital cost due to chiller capacity reductions and reductions in air distribution duct size. With proper design of the fenestration system, other non-economic benefits such as better occupant visual and thermal comfort and potentially improved productivity, and architectural design freedom to specify larger window areas can also be obtained.

Despite these significant potential benefits, daylighting control systems are not routinely specified, having achieved a market penetration of less than 1% in commercial buildings throughout the last 10-15 year history of development. Several reasons contribute to this low level of adoption. 1) Building codes typically regulate either by allowable budget energy consumption per component as a function of space use; e.g., lighting in watts per square foot, or by component swapping on a prescriptive package basis. A/E teams may therefore select independent envelope/ lighting components that yield less than optimum achievable energy performance. 2) There are real and perceived higher cost and higher risk in specifying most current daylighting technologies. 3) Incorrect commissioning of the daylighting system at initial installation and poor operation and maintenance practice leads to improper control of daylight-to-electric light dimming. 4) Poor distribution or improper levels of daylighting for a given task lead to occupant visual or thermal discomfort. Occupants will alter their lighting environment to suit their preferences and, consequently, daylight savings are not achieved.

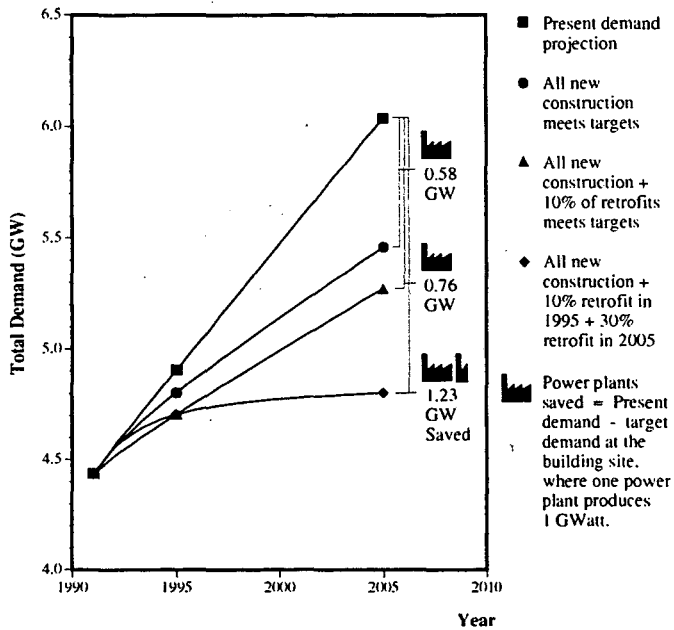

Figure 1. Total potential demand reduction for commercial office buildings in the state of California if new and retrofit construction met lighting and building envelope performance targets for 1995 and 2005 derived in the first phase of this study (Sullivan et al. 1992a).

We believe the solution lies in the development of integrated, intelligent lighting and envelope systems. An integrated system, where all components are designed to work optimally together, offers the benefit of easier specification and less risk and liability for the A/E team, optimum energy efficiency and realizable demand-side management (DSM) potential, and improved occupant satisfaction. An intelligent system, where the system is designed to respond to the variability of internal occupant and external climatological conditions, can ensure sustained performance over time (Figure 2).

We report the second phase results to date of a multiyear project that offers a promising solution to realizing the full DSM potential of integrated envelope and lighting systems in new commercial buildings. Phase I established the project framework for design and analytical methods, set energy and peak demand performance goals, and identified potential market and industry constraints to full commercialization. Several demonstration building projects were also initiated. The primary objective of Phase II was to further develop two conceptual integrated envelope and lighting systems identified in the first phase: 1) dynamic envelope systems that actively modify both daylighting and thermal characteristics to provide energy savings as well as a more comfortable environment throughout the year; and 2) core daylighting envelope systems that extend the depth of daylighting pen-

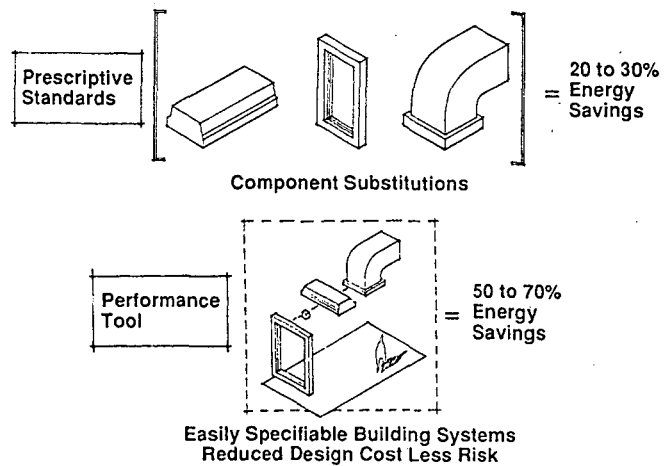

Figure 2. There is a large untapped potential for energy and demand savings with increased comfort and decreased risk if an integrated envelope and lighting systems approach is taken over the prescriptive based, component substitution approach.

etration (~9.14 m (30 ft) target) beyond the perimeter area defined by typical sidelight windows (~4.57 m (15 ft) depth from the window wall), and redistribute daylight more uniformly to achieve a higher level of visual comfort.

Energy and peak demand reductions, and energy cost savings were determined using the DOE-2 building energy simulation program. Field tests, currently in progress, are being used to further validate analytically derived daylighting and thermal performance under outdoor weather conditions. Development of the prototypes into full-scale built systems are being investigated with input from the manufacturing and building industry. Building demonstrations initiated in Phase I as well as new opportunities are being solicited and investigated to provide both full-scale proof-of-concept tests of the advanced prototypical systems and to promote whole-building demonstrations of the integrated concept using existing and emerging envelope and lighting technologies.

PROTOTYPE DESIGN

Smart Dynamic Systems

Static, or fixed, systems often provide an average solution to daylight, heat, ventilation and view for average climatological and occupant conditions throughout the year. Evidence of

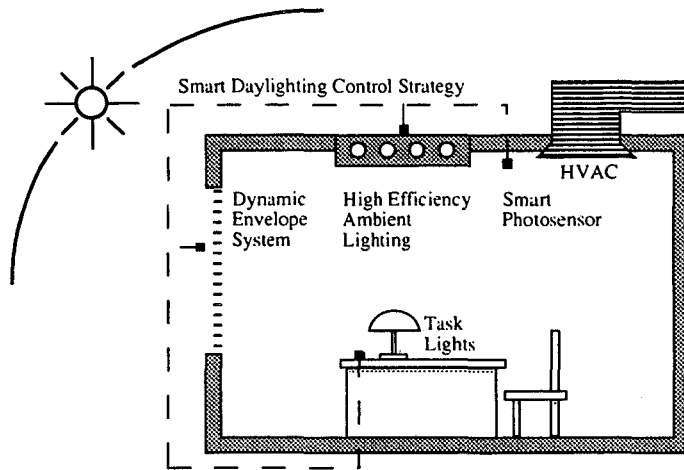

Figure 3. Smart Dynamic Systems Concept.

the inadequacy of this solution can be seen in every workplace: shades are drawn all day to control veiling glare, brightness contrast, and direct sun; aluminum foil is sometimes placed on west-facing windows to reduce solar gains in the hot afternoon hours. Dynamic systems offer the potential to achieve a near to optimum physiological and psychological environment throughout all times of the year with substantial energy and demand savings as an added benefit.

Our first integrated envelope and lighting prototype has been designed to accommodate this notion of flexibility or adaptive intelligence. Initial prototype designs incorporate component technologies that are available today, but are assembled, linked and operated in an entirely new way. Working with a flush skin facade typical of commercial buildings, an interior automated venetian blind is used behind spectrally selective, double pane glazing to control direct sun, admitted daylight, and solar heat gains. The blind is coupled to an advanced electric lighting system (T-8 lamps, electronic ballasts, continuous dimming controls) via photosensor control (Figure 3). As technological advances are made, the automated venetian blind can be replaced by new "switchable" materials such as electrochromics – a new glazing material due to be available in the next three to five years, that can modulate transparency from a clear to colored state with an applied voltage.

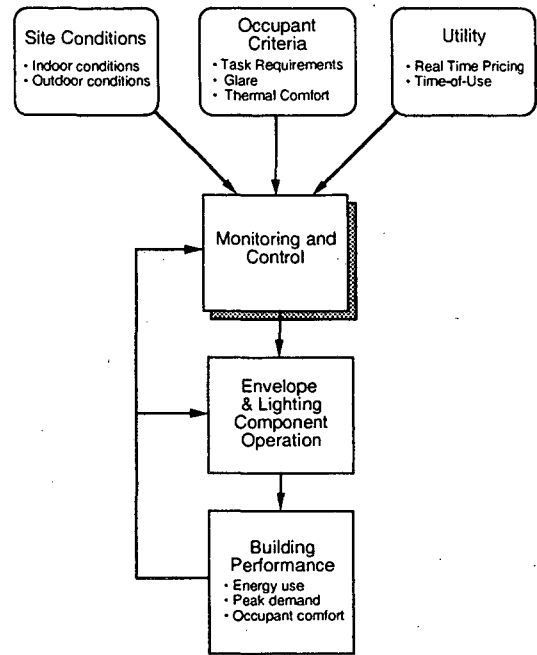

Figure 4. Intelligent building control systems accept multiple inputs then operate dynamic envelope and lighting components to optimize performance. Feedback capabilities for self diagnostics and monitoring can improve system reliability and aid in utility savings verification.

The central focus of our work was to investigate operational control algorithms, the hub about which this concept of adaptive intelligence revolves. There is a growing effort to develop "intelligent" building systems to control start/ stop times for optimal HVAC operation, monitor electrical and HVAC power consumption, and provide a diagnostic history of the zone interior environment. Little, however, has been accomplished in developing control algorithms to optimize fenestration and lighting operation in real-time with respect to energy and occupant comfort (Figure 4).

An optimum energy control algorithm must be able to balance numerous energy and occupant parameters in real-time. For example, to control the cooling load, an electrochromic glazing can be modulated to its least transmissive state, thereby cutting back on admitted solar gains. Perimeter electric lighting linked to daylighting controls, however, will need to increase power to meet the target workplane illuminance level, thereby increasing lighting power consumption and cooling load from electric lighting. In some cases, the optimum energy solution may conflict with occupant comfort preferences.

Most prior research has centered on simple control algorithms that directly reduce building loads. Advanced envelope and lighting control algorithms could integrate with mechanical system operation and utility real-time pricing

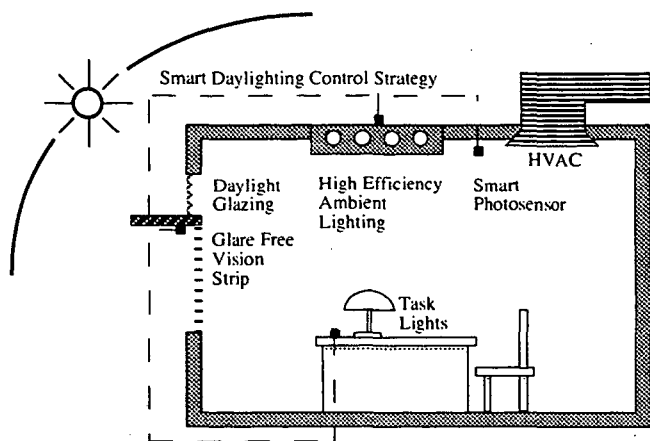

Figure 5. Core Daylighting Systems Concept.

schedules, or tie into centralized energy management control systems for environmental, occupant, and life safety control. Utility DSM programs, however, require savings verification of energy and peak demand reductions to justify outlaid expenditures. Control algorithm design in this project, therefore, concentrated on minimizing energy and peak demand to meet utility DSM goals. Simple control algorithms designed to mitigate instantaneous solar and lighting loads were evaluated first; e.g., block direct sun and optimize workplane illuminance. More complex control algorithms were then explored to compare incremental performance improvements relative to the simpler control algorithms, and to evaluate whether complex, integrated control strategies are warranted within cost and implementation constraints. Methods of decisionmaking between conflicting criteria were researched to determine how to obtain the most energy efficient and desirable solution.

Core Daylighting Systems

Conventional sidelight windows create highly variable thermal and lighting conditions, and significant visual glare from direct sun and non-uniform daylight levels within the space. To control this, occupants often pull shades or blinds down, reducing interior daylight levels and the consequent potential for lighting and cooling energy savings. In addition, the depth of daylight penetration resulting from sidelight windows is relatively small, on the order of 3.0-4.6 m (10-15 ft) for typical window designs, making it difficult to realize larger lighting energy savings using daylighting controls. Core daylighting technologies can extend the area daylit by conventional sidelight windows by redirecting beam sunlight further from the window wall, thereby offsetting electric lighting power consumption and reducing cooling energy due to lighting, without adding, if properly designed, substantial solar heat gains.

The second integrated envelope and lighting prototype consists of an envelope divided into an upper daylighting window aperture and a lower view aperture. The lower view aperture employs spectrally selective glazing with an operable shading device, perhaps the automated venetian blind system proposed above, to control glare, direct sun, and view for those occupants adjacent to the window. The upper daylighting aperture employs a light shelf or light pipe to redirect or transport daylight to deep core areas of the building (Figure 5). The light shelf has been designed to fit within a 0.61-1.52 m (2-5 ft) deep 'articulated' building facade, less commonly used in the United States. The light pipe has been designed to fit within the ceiling plenum similar to a recessed light fixture, with its daylight receiving aperture flush against the glazed spandrel of the building. The light pipe can be used with flush as well as articulated building facades.

The design objectives of the second prototype are to increase daylight output efficiency, depth of penetration, and to improve the uniformity of daylight distribution. Design centered on optimizing aperture size, reflector/ concentrator shape, transport and distribution geometry to complement the unique reflective and transmissive properties of the daylighting optical films and the sun path viewed by the orientation and latitude of the building. Evaluation focused on comparing daylight performance on an orientation basis for the full range of solar positions and clear to overcast sky conditions. Visual quality, glare, and daylight distribution were also evaluated.

METHOD

Design. The development of the prototypical system designs required an iterative approach: starting from a general design concept using rough, quick evaluation methods to gain insight into general performance, progressing towards more accurate evaluation methods to fine-tune the design (Figure 6). Rough daylighting evaluation methods included scale model visualization using lasers and outdoor scale model testing. More accurate energy and daylighting performance evaluation methods included experimental measurements under laboratory conditions combined with DOE-2 building energy simulations (Birdsall et al. 1990).

Daylight Modeling. Existing numerical models cannot accurately predict the daylighting performance of complex systems such as the venetian blinds and the core daylighting prototypes we were investigating in this project, due primarily to their complex geometry and specular surface reflectance. Simulating the daylighting performance of these "optically complex" systems was therefore accomplished using a new method, named IDC (Integration of Directional Coef-

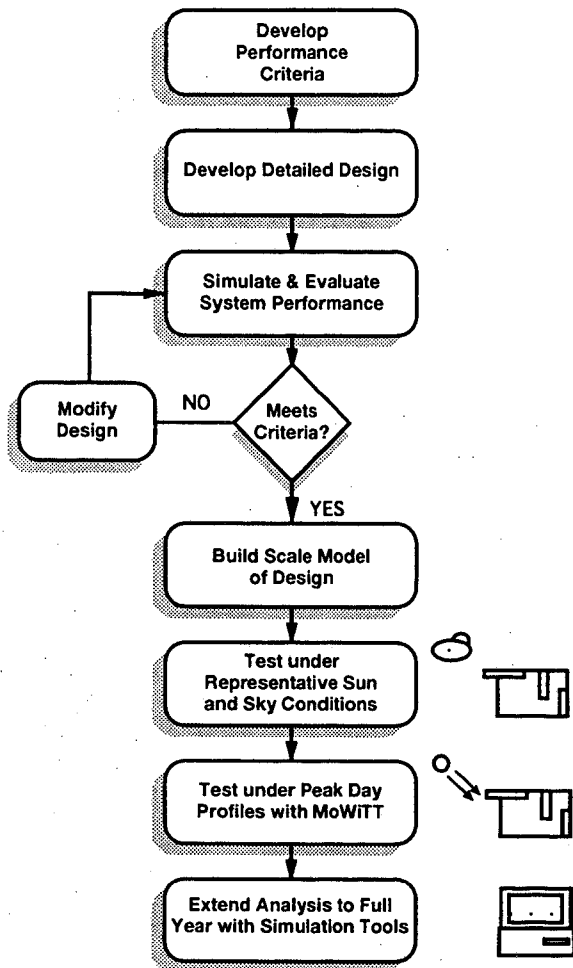

Figure 6. An iterative development sequence was used to design the integrated envelope and lighting prototypes. Initial designs were evaluated using quick analysis methods. Refined designs were then evaluated using more extensive laboratory and field test measurements as well as comprehensive simulation tools.

ficients), which combines experimental photometric measurements with analytical routines to determine daylight factors and daylight illuminance under any sun, sky, and ground condition (Papamichael and Beltrán 1993). IDC coefficients were determined for both prototypes and incorporated into DOE-2 for comprehensive energy performance analysis.

Energy Performance. DOE-2 analysis was used to evaluate energy and peak demand savings of the prototypes. The control algorithms of the dynamic systems were evaluated using a method developed in Phase I of this project (Sullivan et al. 1992b) where the benefits of daylighting (reduced lighting energy and cooling energy due to heat gain from lights) are weighed against the liabilities of daylighting (increased cooling due to solar heat gains). Patterns of energy use and peak demand were investigated for several control

algorithms on a monthly basis. Annual energy performance, peak demand, and cost based on a time-of-use rate schedule, were evaluated relative to a conventional, static clear low-E IG glazing with and without manually operated shades, and advanced electrochromic glazings.

Daylight Quality. Daylight quality was evaluated using outdoor tests and RADIANCE, a ray-tracing computer visualization program (Ward 1990). In outdoor tests using physical scale models, photographs of the daylighting prototypes under clear sky conditions and representative times of the year were taken to visualize the amount of daylight flux redirection, to observe if and when direct sun penetrates the interior space, and to detect the presence of specular reflections or bright areas due to the optical films. RADIANCE modeling coupled with time-lapse videos was used to visualize the variability of the luminance distribution for variable blind tilt angles and periods of the day or year.

Implementation. The dynamic envelope and lighting system was further developed into a reduced scale (1:3) built prototype to determine whether control of the venetian blind and lighting system can be practically implemented using a few simple sensors and controls. While dimming ballasts and control photosensors for electric lighting systems are commercially available, control sensors that automatically adjust venetian blind tilt angles according to solar position or other criteria are not available off-the-shelf. In addition, control systems that optimally integrate operation of both the envelope and lighting system for the purpose of reducing energy usage while maintaining occupant visual comfort are not available.

The prototype integrated control system was implemented in software using a data acquisition and control system to facilitate iterative development without the need to construct physical electronic circuits. Off-the-shelf motorized venetian blinds, lighting system, commercially-available ceiling-mounted photosensor, sun position sensor, and other sensor monitoring components were modified to meet the field test control criteria.

Daylighting Field Tests. The daylighting field test, currently in progress, was designed to evaluate how well the automated venetian blind system satisfied defined control strategy goals in real-time over variable sun and sky conditions. Resolving issues, such as how often to actuate the system under rapidly changing cloudy sky conditions or how much precision is necessary to control the blind tilt angle, can impact the daylight illuminance levels within the space, the realized lighting energy savings, and product costs.

Using the reduced scale model and computer control system described above, we iteratively tested and evaluated the

daylighting performance of the prototype outdoors throughout summer conditions, for the control strategy: block direct sun and maximize view. Data used to assess the performance of the control systems were interior workplane illuminance measured at varying distances from the window and electric lighting power consumption.

Thermal Field Tests. There is a significant dependence of heat transfer on solar incident angle as it varies throughout the day with both season and orientation. Due to the complex optical properties, geometry, and dynamic operation of the venetian blinds, however, there are uncertainties in the hour-by-hour mathematical models used in programs such as DOE-2 to estimate the time-dependent heat transfer through this complex window system under realistic conditions. Accurate predictions of cooling load are critical to the load shape and peak demand concerns of California utilities.

The LBL Mobile Window Thermal Test (MoWiTT) Facility is designed to measure time-dependent net heat flow through a fenestration system of any complexity under realistic conditions. The facility consists of accurate, twin room-sized calorimeters that can simultaneously measure the performance of two fenestration systems under identical outdoor conditions. The test, due to commence this September, has been designed to measure the thermal conditions for an automated interior venetian blind system combined with double-pane selective low-E glazing with daylighting controls. The venetian blinds will be operated to block direct sun and maintain workplane illuminance. Measurements for exterior climate conditions, interior environmental conditions, and energy flows will be used to calculate the net heat flow through the fenestration.

Commercialization. To understand how the prototypes will fit within the context of the real-world, meetings with window, lighting, and control system manufacturers, architects, and energy consulting firms were held to introduce the general concept of systems integration and to discuss the viability of specific prototype systems. Manufacturers were solicited either to comment on how the prototypes could be manufactured or mass produced given the constraints of cost and the market; or to work as partners in the development of new products. Architects and engineers were informed of potential integrated solutions through magazine articles (Lee and Selkowitz 1993) or through face-to-face discussions and collaborations on demonstration projects.

Demonstrations. Demonstrations of emerging energy efficient technologies in highly visible building projects with comprehensive end-use monitoring and user feedback can be used to convince the risk-averse building industry to adopt new demand-side management measures and can satisfy utility savings verification needs. Testbed demonstrations in

small portions of existing buildings are proposed as a transition between the field tests described above and full scale demonstrations in occupied buildings. Collaborative demonstration projects with utilities and with private sector developers using commercially available technologies were also pursued to help promote the integrated envelope and lighting system concept.

Several potential building sites were identified through contacts with existing utility demonstration programs. For each potential site, the appropriateness of the building design, utility/ architect/ building owner relationship, and project schedule was assessed to understand the requirements and possibilities for cooperative work. If the demonstration opportunity was considered appropriate, a working relationship was established to provide guidance in the selection and evaluation of various design strategies and component technologies. The level of expertise offered on these demonstration projects ranged from distributing general information about available products related to the integrated design approach to specific analysis of actual building designs. Additional assistance was given to provide cost data and product specifications from manufacturers.

RESULTS

Smart Dynamic Systems

If the automated venetian blind system is operated to mitigate instantaneous solar and lighting loads, i.e. block direct sun and optimize workplane illuminance levels within a 4.57 m (15 ft) deep perimeter zone, the venetian blind system can achieve a 16-26% annual electricity consumption savings and a 17-24% peak demand savings over a conventional unshaded low-e glazing with daylighting controls. If the venetian blind system is compared to the same system without daylighting, the savings are substantially higher: 42-47% annual electricity savings and 22-29% peak demand savings. These perimeter zone energy savings (core not included) are achieved for the south, east and west-facing orientations of a prototypical office building module in Los Angeles (Figures 7 and 8). The automated venetian blind was operated by altering louver tilt angle to block direct sunlight and to control both quantity and direction of transmitted daylight.

As a basis for comparison with more advanced envelope systems, we modeled two types of electrochromics in DOE-2: the broad-band electrochromic exhibits performance characteristics of products that will be available in the next three to five years ($SC=0.26-0.84$; $Tv=0.09-0.70$); the narrow-band electrochromic exhibits performance characteristics that have better solar heat rejection ($SC=0.11-0.50$) while maintaining comparable daylight transmissivity ($Tv=0.09-$

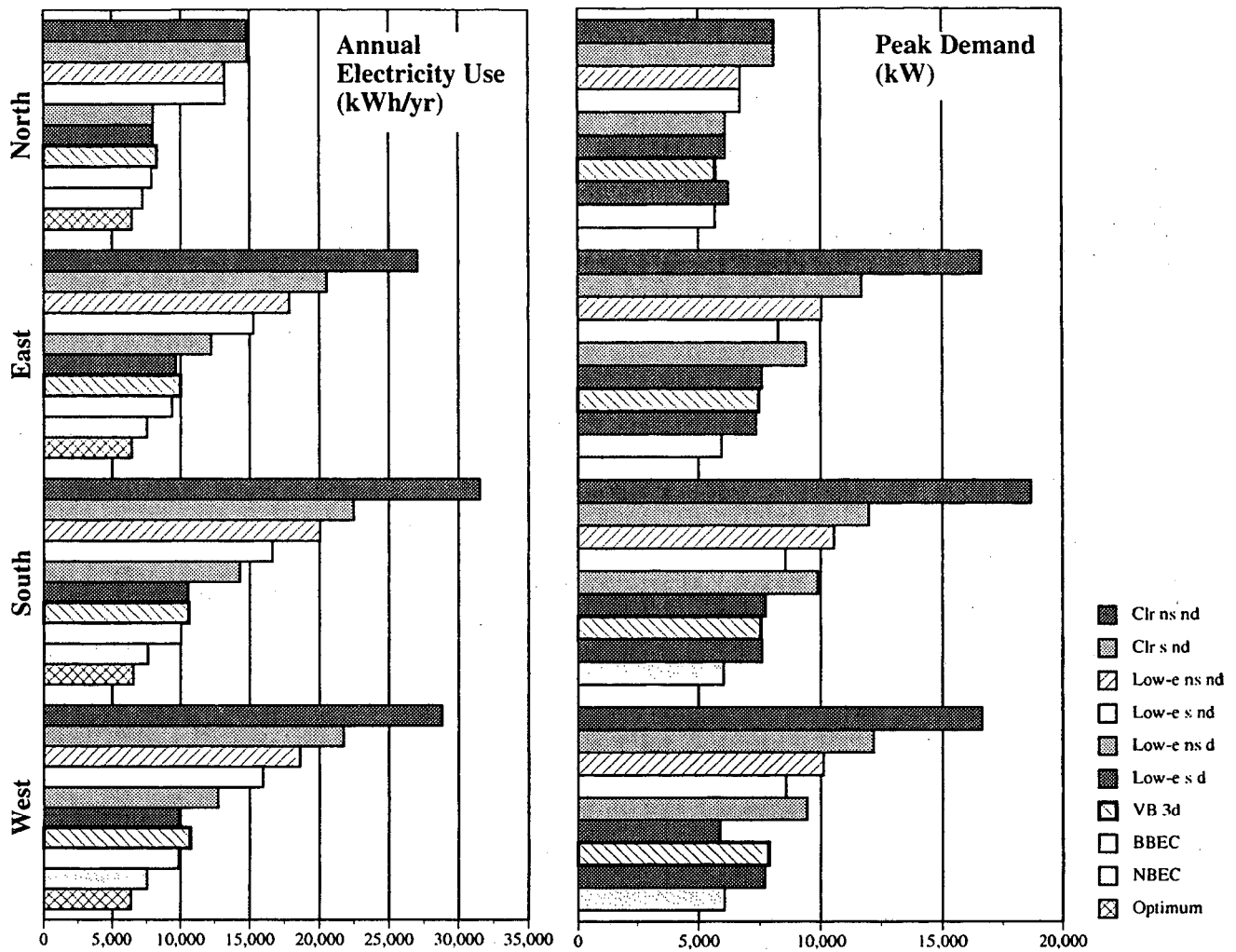

Figures 7 and 8. Annual electricity use (kWh/yr, left) and peak demand (kW, right) for 139 m² (1500 ft²) prototypical commercial office building zones in Los Angeles. Data show the performance of conventional clear glazing, low-E IG glazing, an automated venetian blind system (VB) controlled to block direct sun and optimize workplane illuminance, broad-band (BBEC) and narrow-band (NBEC) electrochromic glazings, and a hypothetical optimum envelope and lighting system. All systems use continuous daylighting controls at a design lighting level of 538 lux (50 fc) and a lighting power density of 16.1 W/m² (1.5 W/ft²). Note: (ns) no shading, (s) manually operated shades, (nd) no daylighting controls, (d) daylighting controls. No optimum was computed for peak demand.

The broad-band electrochromic can achieve slightly higher savings than the blinds system – 23-30% electricity savings and 18-23% peak demand savings; whereas, the narrow-band electrochromics can achieve the highest savings – 38-47% electricity savings and 36-39% peak demand savings, due to its ability to exert tighter control over solar heat gains while maintaining comparable daylighting transmissivity. The narrow-band electrochromic closely approaches the ideal envelope system. The maximum achievable savings are 47-54% electricity savings, defined by a hypothetical system that admits the design workplane illuminance level (538 lux (50 fc) in this case) during all daylight hours without admitting any solar heat gains.

0.71) as the broad-band electrochromic and may become available in the next 5-10 years¹. The electrochromic glazings were operated to maintain design workplane illuminance levels through modulation of transparency from a clear to darker colored state (See Lee et al. 1993 for full report).

¹ Shading coefficient (SC) is a measure of total solar heat gain including both directly transmitted solar radiation and the indirect component of inward flowing heat due to absorption by the glazing. The visible transmittance (Tv) is defined as the percentage of visible light transmitted through the glazing.

The automated venetian blind system performance can be improved through more precise operation of the blinds (we modeled discrete blind tilt angles – continuous movement of the blinds will result in tighter control of interior daylight levels) or by modifying the geometry and surface properties of the blind. More sophisticated control strategies were explored, such as seasonal control algorithm design and multi-criteria control strategies. Further investigation will be needed to define algorithms that can mathematically predict the transient behavior of the building given the thermal capacitance of the building and characteristics of the mechanical system. Additional research will also be needed to design the control algorithm to satisfy multiple criteria (energy, peak demand, visual comfort, etc.).

Implementing the prototype system with real hardware and software presented numerous challenges. Several sun position sensors were designed and tested to determine if the “block direct sun” portion of the control algorithm could be implemented without a real-time controller (a real-time clock increases system cost and complexity for localized single zone control). Open-loop control of both the venetian blind and lighting system from an externally mounted photosensor was also tested. Initial daylighting field test results indicate that integrated control of both the envelope and electric lighting will require input from both local and global sensors. Local sensors, such as a ceiling-mounted photosensor, are used to serve a particular office or open plan zone. Global sensors, such as a real-time clock, provide information to multiple zones and are therefore less expensive on a per square meter basis. Successful operation of the integrated envelope and lighting system will therefore require centralized building control with an open protocol network to distribute intelligence to localized zones within the building.

Through product research and discussions with manufacturers, architects, engineers, and other research facilities, the interest and trend toward sophisticated intelligent dynamic systems was confirmed. Many of these systems are being marketed on the basis of providing energy efficient solutions with a degree of individual control to enhance worker comfort and productivity. Linked to energy management control systems (EMCS), the systems can provide diagnostic and monitoring information for DSM savings verification needs. Several utility DSM programs have specified or installed envelope systems with automated louver systems. A R&D manufacturing company outside of the building industry has developed and installed sophisticated occupant based lighting control systems that may eventually be tied to envelope controls. Numerous European manufacturers have created lighting management systems based on an advanced networking technology to facilitate distributed control and reconfiguration. Further development of intelligent micro-processors and energy management control systems will

continue to drive costs down over the next ten years.

Attempts to demonstrate the smart prototype in a new or existing building with existing utility sponsored demand-side management programs have not been successful to date due in part to incompatible schedules and other building project constraints. In the next phase of research, we will initiate a small testbed demonstration of the smart prototype in two to three offices of an existing building to assess full scale performance under occupied conditions. A potential utility collaboration to commission and test a proposed automated skylight system in a new construction project is also currently under consideration.

Core Daylighting Systems

Both the light shelf and the light pipe prototypes were designed with the objective of maximizing the redirection of sunlight to depths of 9.15 m (30 ft) from the window wall, with supplemental daylight contributed from a lower view window for the first 4.57 m (15 ft) from the window. The prototypes were tailored to utilize *direct* sunlight because diffuse daylight from either the sky or surroundings is more difficult to control and contributes insignificant daylight illuminance due to its lower intensity (sunlight is ~4-7 times brighter than skylight).

The design and evaluation of the daylighting technologies, a light shelf and light pipe design, involved a lengthy series of visualization and outdoor physical model tests, and IDC analyses. Results from the outdoor tests informed the redesign and tuning of the daylighting designs. Designs were altered slightly to improve the system geometry and use of the daylighting optical films, then remeasured using the IDC method.

The input aperture for both prototypes evolved into reflectors that block direct sun to prevent direct source glare and redirect sun according to the altitude and azimuth angles of the sun throughout the year. The input aperture area was further constrained to reduce solar heat gains. For the light shelf, highly reflective daylight films ($r=0.90$) with a slight beam spreading effect (12-15° spread) were used to redirect incident flux to the ceiling plane 7.62-9.15 m (25-30 ft) from the window. Interreflections off the ceiling plane and walls distributed daylight to the workplane surface (Figure 9). For the light pipes, similar reflective daylight films and geometry were used to redirect and concentrate daylight along the longitudinal axis of the pipe, minimizing interreflections and daylight losses. The transport section of the pipe was designed with a combination of highly reflective films ($r=0.90-0.95$). The distribution section used a transmissive/reflective film to spread light downwards to the workplane surface (Figure 10).

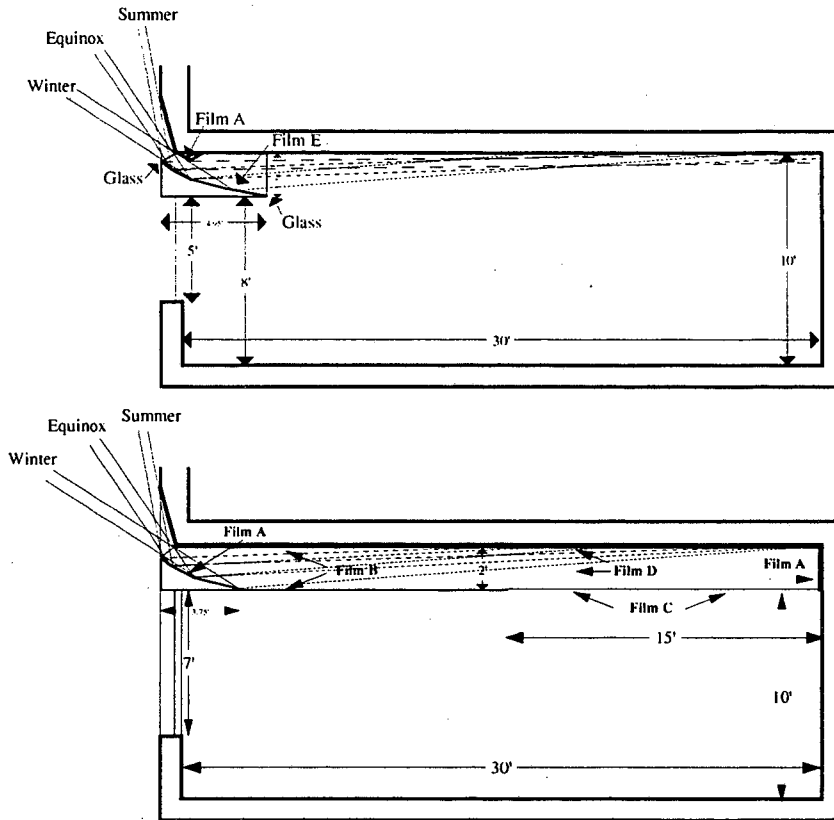

Figure 9 (top). Ray tracing diagram for the south facing light shelf prototype. The reflector shape is designed to redirect incoming direct sun to a target area on the ceiling plane at 7.62 m (25 ft) from the window. Solar altitude and azimuth varies throughout the year – we show the extreme range of solar altitudes in this diagram: December 21, March/ September 21, and June 21.

Figure 10 (bottom). Ray tracing diagram for the south facing light pipe prototype. Using a similar reflector shape and optical daylight films as the light shelf, the light pipe reflector is designed to concentrate incoming daylight along the longitudinal axis of the pipe in order to minimize interreflections along the pipe transport section and maximize daylight efficiency. The extreme range of solar altitudes are shown in this diagram: December 21, March/ September 21, and June 21.

Results from the IDC analyses, given here for Los Angeles (latitude 34°N) are promising, but also indicate the need for further refinement of the designs. For example, for the south-facing light shelf (upper aperture only), the workplane illuminance level at a distance of 8.38 m (27.5 ft) from the window wall is over 400 lux (37.2 fc) throughout the year for surface solar azimuth¹ angles, $\gamma < 60^\circ$, and remains over 50 lux (4.6 fc) for $60^\circ \leq \gamma \leq 90^\circ$. Additional daylight is provided by the lower view window. These daylight levels are given for the direct sun contribution only, since the clear sky contribution

¹ Surface solar azimuth is defined as the angle between the surface outward normal of the window and the solar azimuth angle.

were relatively small: less than 25 lux (2.3 fc) throughout the year. These daylight levels are achieved for an aperture that is only 0.18 m (0.6 ft) high across the width of the room, with a total input aperture area of 1.11 m² (12 ft²). The distribution of daylight in the 4.57-9.14 m (15-30 ft) workplane area from the window wall is fairly uniform under clear sky conditions, varying $\pm 6-8\%$ for all solar altitudes throughout the year for $\gamma = 0^\circ$. Less uniformity occurs for sun angles that are not directly in front of the window since redirected daylight falls on the upper wall surfaces for very oblique sun angles. For open plan offices where no sidewalls obstruct redirected daylight, distribution will be more uniform for oblique sun angles. For individual offices, sidewall reflectors may improve light output efficiency.

The light pipe designs performed less consistently throughout the year than the light shelf designs, primarily due to the smaller aperture area studied (0.15-0.37 m² (1.6-4.0 ft²)) and the point versus linear aperture opening. Daylight levels and distribution can be improved if the input aperture area is increased or if more than one light pipe is used. The inefficiency of the light pipe for oblique sun angles is due primarily to the increased number of interreflections within the transport section since admitted daylight is not collimated along the longitudinal axis of the light pipe. To improve efficiency for oblique sun angles, the geometry and surface properties of the light pipe sidewalls can be altered from the current design (see Beltrán et al. 1993 for full report).

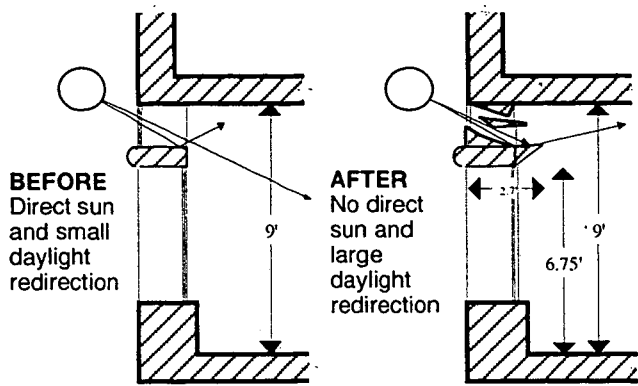

Figure 11. Before and after case of light shelf design. This building has built and installed the left light shelf design. We proposed a new design that could be retrofit onto the existing system. The thickness of the light shelf was reduced to accommodate the design preferences of the architect.

Several demonstration projects were initiated with utility DSM programs to determine the viability of installing the light shelf prototype in new and retrofit commercial buildings. In a new construction commercial office building, we were able to convince the architects to modify their proposed light shelf design simply by illustrating the before and after daylighting performance through physical scale model visualization. The building, however, is currently on-hold pending funding approval. In a second office building where a light shelf was already installed but the building had not yet been occupied, the architects were concerned about glare from incoming direct sun through the light shelf aperture. We worked with the architects to alter their existing design to accommodate a modified version of our light shelf prototype (Figure 11); cost of the system as a retrofit option, however, was deemed too high. We are currently working with Southern California Edison and Sacramento Municipal Utility District to adapt the light shelf and light pipe prototypes to several other new and retrofit demonstration projects.

Commercialization of the core daylighting prototypes appear to have less technical obstacles and market barriers than the smart dynamic prototype. This may be due in part to the simplicity of the concept (bring daylight in, turn off the lights) and how the systems can be marketed. For example, we worked with a major window manufacturer and a national retail chain to design and evaluate several skylight systems for the single-story warehouse-like stores. The manufacturer was successful in installing several finalized skylight prototypes in a demonstration “green” retail store, resulting in widespread publicity in magazines such as Time and Businessweek.

CONCLUSIONS

Two prototype integrated envelope and lighting systems were developed that fit standard commercial building typologies. The first employs a dynamic intelligent envelope that can serve to adapt to occupant criteria, energy performance goals, and time-of-use rate schedules. The second seeks to improve visual comfort and to extend the daylight energy savings to the core of the building. Both systems are comprised of the latest in glazing, shading devices, lighting, and energy management control systems.

Energy performance analysis indicates that significant energy consumption and peak demand reductions can be obtained from the smart integrated prototype using off-the-shelf components to actively control instantaneous lighting and cooling loads. The performance of this mid-term option is comparable to the more advanced electrochromic glazing systems, that should be available in the next five to ten years. A sophisticated control system that allows customization of control criteria will be needed if multiple criteria such as energy, comfort, and cost parameters are to be accommodated. A small scale testbed demonstration is planned for the next phase of research to more fully test the daylighting, thermal, and occupant response to this dynamic system.

On southern facades, core daylighting prototypes can provide substantial daylight to deep perimeter zones in the building (< 9.14 m (30 ft)) using only small input apertures without excessive solar gain. East and west-facing prototype designs will require further refinement.

Collaborative demonstrations with current utility DSM programs will enable us to further refine the designs for real-world applications. Development of improved design tools is also planned for the next phase of the project so that design professionals can quickly and accurately develop and evaluate high performance envelope and lighting design solutions.

ACKNOWLEDGMENTS

The authors are indebted to their LBL colleagues, Greg Ward, for his assistance in RADIANCE modeling, to Fred Winkelmann and W. Fred Buhl for their assistance in DOE-2 modeling, and to Guy Kelley, Mehry Yadzaniyan, Michael Streczyn, and Jonathan Slack for their assistance with the MoWiTT facility. Thanks are also due to doctoral students, Christopher Pawlawsky and Andrew Hamilton, for their work with the computer control and data acquisition system, and to student assistants, Paul Fritz, Ernie Ngo, and Jessica Rothschild, for their assistance in building physical models for testing.

This research was funded by the California Institute for Energy Efficiency (CIEE), a research unit of the University of California. Publication of research results does not imply CIEE endorsement of or agreement with these findings, nor that of any CIEE sponsor. Additional related support was provided by the Assistant Secretary for Energy Efficiency and Renewable Energy, Office of Building Technologies, Building Systems and Materials Division of the U.S. Department of Energy under Contract No. DE-AC03-76SF00098.

lope systems. LBL Report 33075, Lawrence Berkeley Laboratory, Berkeley, CA.

Sullivan, R.; E. S. Lee; and S. Selkowitz 1992b. A method of optimizing solar control and daylighting performance in commercial office buildings. Proceedings of the ASHRAE/DOE/BTECC Conference on the Thermal Performance of the Exterior Envelopes of Buildings V, Clearwater Beach, FL, December 7-10, 1992. LBL Report 32931, Lawrence Berkeley Laboratory, Berkeley, CA.

Ward, G. 1990. The Building Process: Visualization. LD+A, Vol. 20, No. 6, June 1990, pp. 4-20.

REFERENCES

Beltrán, L.O.; E.S. Lee; K.M. Papamichael; and S.E. Selkowitz 1993. The design and daylighting evaluation of advanced light shelves and light pipes. Draft Working Information, Phase II of the California Institute for Energy Efficiency (CIEE) multiyear project "Envelope and Lighting Technology to Reduce Electric Demand," Lawrence Berkeley Laboratory, Berkeley, CA.

Birdsall, B.; W.F. Buhl; K.L. Ellington; A.E. Erdem; and F.C. Winkelmann 1990. Overview of the DOE-2 Building Energy Analysis Program, Version 2.1D. LBL Report 19735, Rev. 1, UC-350, February 1990, Lawrence Berkeley Laboratory, Berkeley, CA.

Lee, E.S. and S.E. Selkowitz 1993. Integrated design yields smart envelope and lighting systems. Consulting-Specifying Engineer, Cahners Publishing Company, Des Plaines, IL, June, pp. 64-70.

Lee, E.S.; R. Sullivan; K. Papamichael; and S. Selkowitz 1993. Dynamic lighting and envelope systems: Automated venetian blinds and electrochromics. Draft Report, Phase II of the CIEE multiyear project "Envelope and Lighting Technology to Reduce Electric Demand," Lawrence Berkeley Laboratory, Berkeley, CA.

Papamichael, K. and L. Beltrán 1993. Simulating the daylight performance of fenestration systems and spaces of arbitrary complexity: The IDC method. Proceedings of the 3rd International Conference of the International Building Performance Simulation Association, Building Simulation '93, August 16-18, 1993, Adelaide, Australia. LBL Report 33945, Lawrence Berkeley Laboratory, Berkeley, CA.

Simulation Research Group 1985. "DOE-2 Supplement: Version 2.1C," Lawrence Berkeley Laboratory Report LBL-8706, Rev. 4 Supplement, Lawrence Berkeley Laboratory, Berkeley, CA.

Sullivan, R.; E. S. Lee; and S. Selkowitz 1992a. Impact assessment and performance targets for lighting and enve-

LAWRENCE BERKELEY LABORATORY
UNIVERSITY OF CALIFORNIA
TECHNICAL INFORMATION DEPARTMENT
BERKELEY, CALIFORNIA 94720

AAS313



LBL Libraries