

# Lawrence Berkeley National Laboratory

## Lawrence Berkeley National Laboratory

**Title**

THE PASSIVE SOLAR DESIGN PROCESS FOR A SMALL OFFICE/LABORATORY BUILDING

**Permalink**

<https://escholarship.org/uc/item/70n4g5pc>

**Author**

Andersson, Brandt

**Publication Date**

1979-10-01

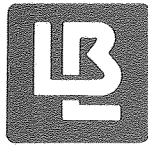

# Lawrence Berkeley Laboratory

UNIVERSITY OF CALIFORNIA

## ENERGY & ENVIRONMENT DIVISION

Presented at the International Conference on Energy Use Management,  
Los Angeles, CA, October 22-26, 1979

THE PASSIVE SOLAR DESIGN PROCESS FOR A SMALL  
OFFICE/LABORATORY BUILDING

Brandt Andersson, Ron Kammerud, and Wayne Place

October 1979

### TWO-WEEK LOAN COPY

*This is a Library Circulating Copy  
which may be borrowed for two weeks.  
For a personal retention copy, call  
Tech. Info. Division, Ext. 6782.*

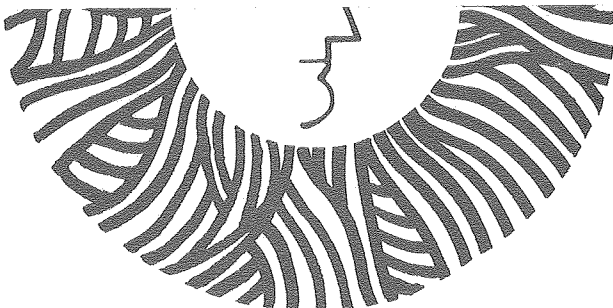

RECEIVED  
LAWRENCE  
BERKELEY LABORATORY

JAN 14 1980

LIBRARY AND  
DOCUMENTS SECTION

LBL-9294 C.2

## **DISCLAIMER**

This document was prepared as an account of work sponsored by the United States Government. While this document is believed to contain correct information, neither the United States Government nor any agency thereof, nor the Regents of the University of California, nor any of their employees, makes any warranty, express or implied, or assumes any legal responsibility for the accuracy, completeness, or usefulness of any information, apparatus, product, or process disclosed, or represents that its use would not infringe privately owned rights. Reference herein to any specific commercial product, process, or service by its trade name, trademark, manufacturer, or otherwise, does not necessarily constitute or imply its endorsement, recommendation, or favoring by the United States Government or any agency thereof, or the Regents of the University of California. The views and opinions of authors expressed herein do not necessarily state or reflect those of the United States Government or any agency thereof or the Regents of the University of California.

THE PASSIVE SOLAR DESIGN PROCESS  
FOR A SMALL OFFICE/LABORATORY BUILDING\*

Brandt Andersson, Ron Kammerud Wayne Place  
Passive Solar Group  
Lawrence Berkeley Laboratory  
Berkeley, California 94720

ABSTRACT

In order to assess the compatibility of existing passive solar design tools with the architectural process, a case study design for a small commercial building has been performed. The architectural process employed in the design is presented, the areas within the process for which appropriate tools are not immediately available are identified, and some improved tools are proposed. The potential advantages of passive solar design for a small commercial building in an adverse climate are demonstrated.

INTRODUCTION

Changes to the basic architectural design of buildings can provide significant energy savings beyond that possible with conventional conservation measures; such changes can allow the building to selectively interact with the environment in order to utilize available environmental resources and thereby reduce the heating and/or cooling load of the structure. "Passive solar" systems depend largely on the ability of the architect to provide for appropriate environmental interaction. Collection, storage, and distribution of solar energy in passive systems usually take place within the structure, so they are integral to the architecture.

In order to realize maximum benefits from passive solar designs, more common conservation measures must also be considered in early stages of the design process. Effective designs result from a thorough examination of the relationship between architectural and energy considerations for a structure. To better define the ability of existing design tools to accommodate the complex relationships in commercial buildings, DOE is supporting case studies in which DOE laboratory personnel become involved in the building design process. This paper describes a case study performed by the Passive Solar Group of the Lawrence Berkeley Laboratory: the design of a building for the Pittsburgh Energy Technology Center. The building, which will house 8000 ft<sup>2</sup> of office and laboratory space, is under consideration for DOE construction support.

OBJECTIVES

Prior to the beginning of the study, a conceptual design and report had been prepared by a contracted A/E firm. It was clear that a well-organized, compact, low-cost design had been generated (Figures 1 & 2).

---

\*This work was supported by the Passive and Hybrid Systems Branch, Systems Development Division, Office of Solar Applications, U.S. Department of Energy, under Contract No. W-7405-ENG-48.

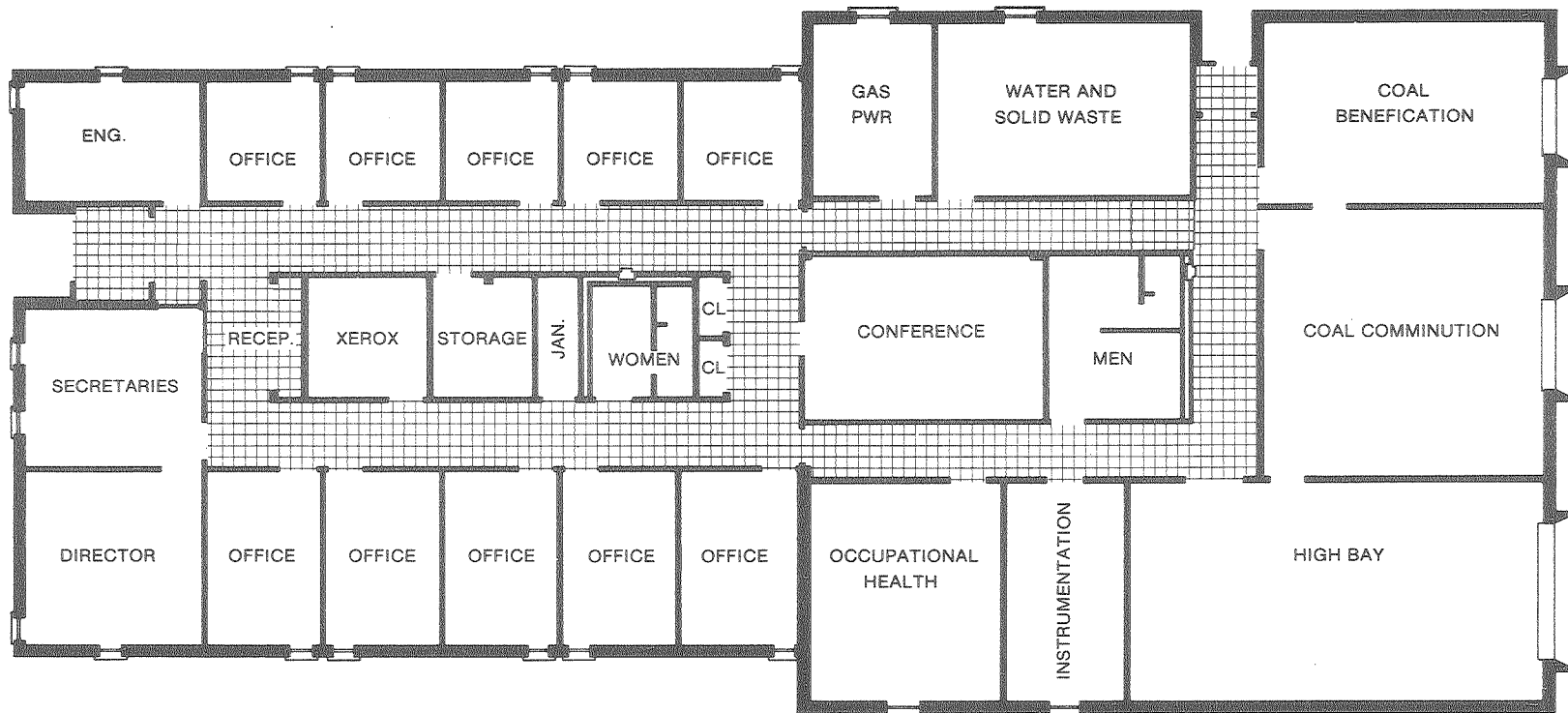

-2-

XBL 7910-12441

FIGURE 1: PLAN — ORIGINAL DESIGN.

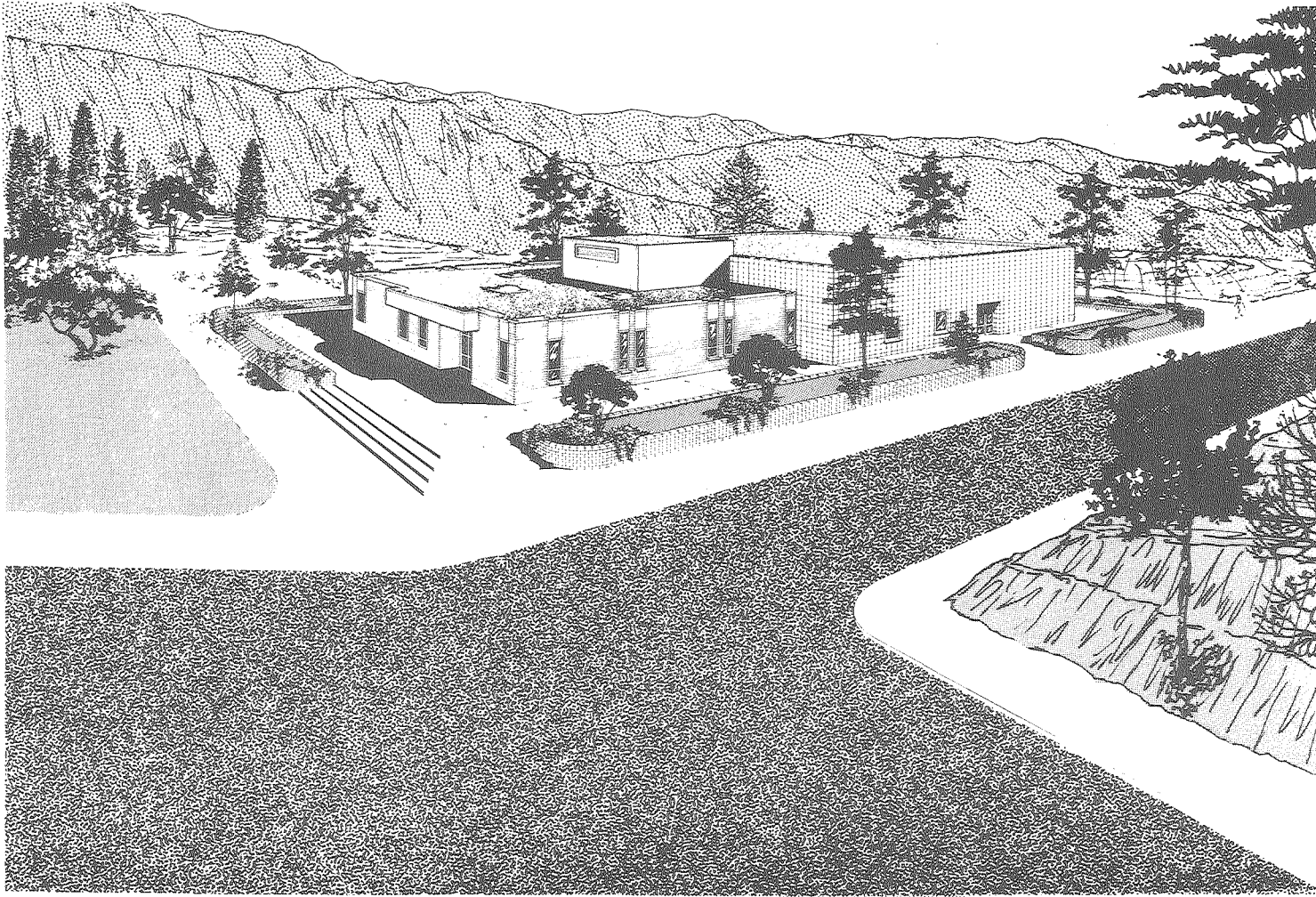

XBL 799-11771A

FIGURE 2: PERSPECTIVE — ORIGINAL DESIGN.

It was equally clear that architectural concern with energy had been limited to conformance with the energy standards in the ERDA General Design Criteria (1). There was no evidence that important thermal considerations such as building orientation, glazing distribution, potential buffer spaces, and insulation levels beyond minimum standards had been considered.

The role of LBL was to review the design and make recommendations for its improvement, especially with regard to integration of passive solar techniques. Specific goals of the study were:

- to apply existing design tools -- graphic techniques, hand calculations, and computer simulations -- to the design process;
- to identify areas within the process for which appropriate tools are not presently available;
- to evaluate possible roles for passive solar in small commercial buildings, in a cold, cloudy climate.

This paper describes the process used in generating passive alternatives and presents an assessment of the tools available for that process.

#### BUILDING PROGRAM ANALYSIS

The Conceptual Design Report and the design itself established the architectural program and the intent of the original designers. Two important qualities of the original design established directions for development of a passive variation:

- (1) The organization was conceptually simple, with clear definition of important spatial relationships.
- (2) Emphasis was placed on construction economy, using masonry cavity walls, metal roof deck, and concrete slab floors.

In contrast to the original design, where energy conservation was limited to mechanical equipment (heat pumps, evaporative coolers, active solar heating and underground thermal storage), the passive solar redesign emphasized selection of an appropriate architectural configuration based on evaluations of the thermal benefits. A cost-benefit analysis accounting for daylighting and mechanical equipment changes is required to make a final judgment on the merits of the proposed alterations.

#### DESIGN PROCESS AND DESIGN TOOL EVALUATION

Steps in the design process are described with reference to these questions:

- What decision regarding energy use must be made?
- What methods are currently available to assist in making a more informed decision?
- What additional design tools are needed?

Not all of the steps in the design process have been described here; several important steps have been chosen to illustrate some of the methods used and conclusions reached during this project.

#### Site and Climate

In this project, two sites were available. Both are flat and have essentially clear solar access. Available methods for determining solar access using contour maps or simple observation are adequate, and need not be expanded upon here.

Climatic data was needed to determine both the demands placed on the building by local weather, and the environmental potentials for passive

heating and cooling. At a preliminary design stage, general measures of climate are usually sufficient. Monthly weather data, in terms of means and extremes of several indicators, is available from a variety of sources (2). In Pittsburgh, heating loads are high because of long, cold, windy winters. Cooling is the more important consideration for 4 months, but the annual effect is relatively small (1000 cooling degree days vs. 5000 heating degree days). Passive solar potentials are not encouraging. Heating is the major concern, but the sun shines less than 30% of the time in winter. Furthermore, modest daily temperature swings and summer humidity limit the potential for reducing the cooling load through passive means.

### Window Orientation

The first passive alternative involved modifying the original design by moving corridors to the south and east perimeter and substantially increasing the glazing on these walls. It was thought that the corridors could act as buffer spaces for both conduction losses and solar gains. The east orientation was considered for the possible contributions to morning heating.

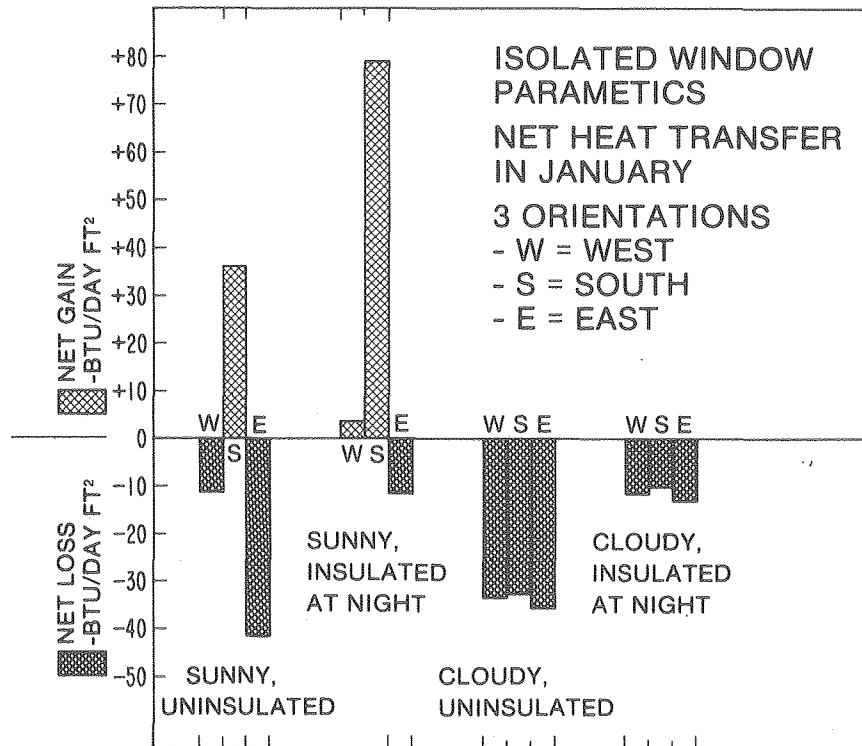

XBL 798-10758

FIGURE 3: WINDOW PARAMETRICS.



An initial assessment of the potential benefits from the glazing was made using the computer program BLAST (Building Loads Analysis and Systems Thermodynamics\*). BLAST can calculate hourly heating and cooling loads based on detailed weather data and a description of the structure. A construction was described to the program which eliminated all of the heat flows except those through one window. Thus, the net effect of the window was evaluated in three orientations (east, south, west), on sunny and cloudy days, and with and without additional insulation at night. All runs used double pane glass. January weather was used to obtain "worst case" information. The results are displayed in Fig. 3. The graph shows that east and west windows will not help the deep winter heating load. South windows achieve a substantial net heat gain on sunny days; night insulation enhances their performance on both sunny and cloudy days. The implication is clear: south windows can achieve passive direct-gain heating in this climate.

Use of BLAST allowed the first passive design to be discarded before much time had been spent on its development. Unfortunately, BLAST is not available to most architectural offices, and it is unlikely that many firms will ever make extensive use of such a program for this purpose. A tool is needed which can provide the architect with rapid information on a variety of window types under a wide range of conditions (climate, orientation, time of year, etc.). Such a tool could be generated using information derived from a series of runs on a program like BLAST. The results, compiled and distributed, would give the designer simple, readable tables or graphs from which he could choose the most appropriate window configuration for his particular architectural and energy problems.

### Shade Design

Shading devices can effectively limit the summer cooling load for a building with substantial areas of south glass. A procedure based on a sunchart served as the tool to design a shade for the new passive design with extensive south glazing (Fig. 4). Average temperatures were plotted on the chart to assess when solar gain would be beneficial (some adjustment is necessary to account for internal loads and ventilation effects). From the sunchart, profile angles (which determine the amount of shading from an overhang) can be identified. In this case, when the sun casts a profile angle of  $65^{\circ}$  or greater on a south window, full shading is desired because a cooling load exists. When the angle is  $45^{\circ}$  or less, full penetration of direct-beam solar radiation is preferred to counteract the heating load.

The requirements for the "ideal" shade are graphed in Fig. 5a. A good shade will have a graph similar to the ideal and be compatible with the architecture. Fig. 5b shows three possible shades, displayed over a window section. The section can be used to determine graphically the shading coverage at various angles. Plotting the results on the graph one can compare the effect to the ideal shade. The first shade (S1) conforms to the requirements exactly but is too large and too high for serious consideration. The smaller shade (S2) and the louvered shade (S3) both result in reasonable approximations, although S3 obstructs beneficial sun at lower angles. Those low angle effects and simpler

\*BLAST is copyrighted by the Construction Engineering Research Laboratory, U. S. Department of the Army, Champaign, Illinois.

construction make S2 the better choice for this project.

### DESIGN OF IDEAL OVERHANG FOR SOUTH WINDOWS

40° SUN CHART  
(40° N. Lat.)

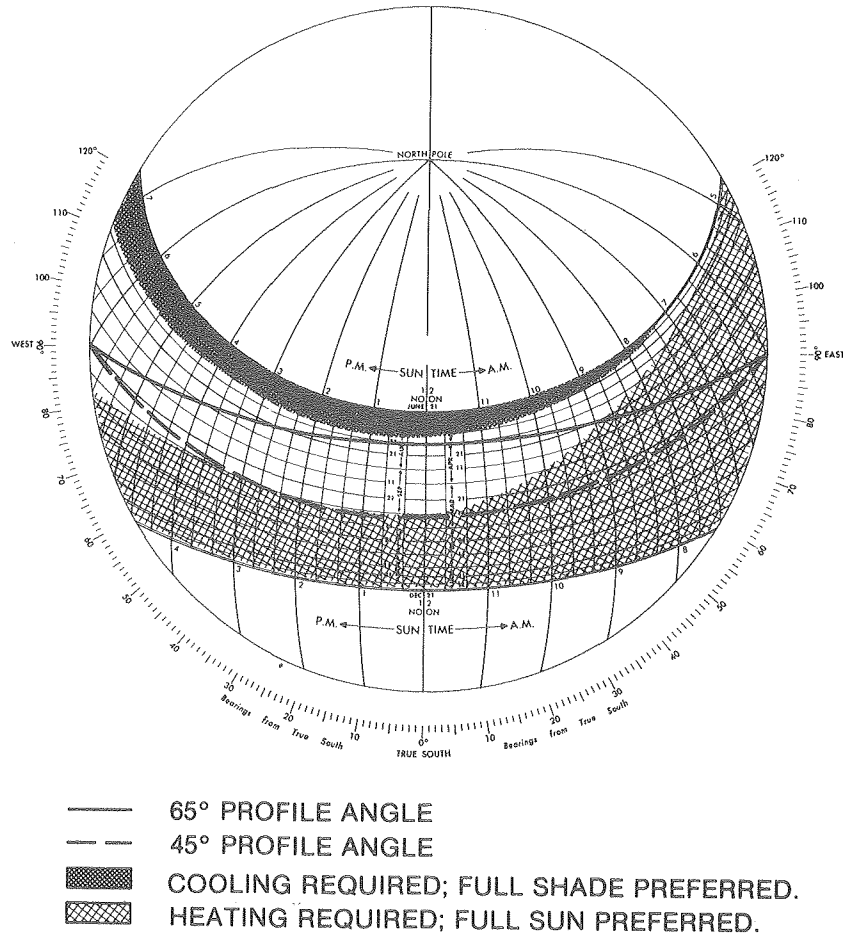

XBL 798-10776

FIGURE 4: SUN CHART — PITTSBURGH.

This shade design technique is straightforward but time consuming. A simple computer program could be written to generate percent-sunlit vs. profile-angle graphs for a wide variety of solid, slotted, and louvered shades. Once an architect had plotted a graph of the ideal shade for his window, the most appropriate solution could be found quickly.

Similar techniques are equally appropriate for vertical shades on windows in various orientations. Horizontal reflectors on the ground or roof (for clerestories) can also be designed using this method, as shown in Figures 5c and 5d. In this case, reflectors of type R1 or R2 on the roof of the office zone could enhance solar gains through the clerestory windows.

### SHADING DESIGN

GOALS FOR RADIATION ON SOUTH WINDOWS

1. No direct radiation at 65° - 90° profile angle
2. All of potential direct radiation at 0° - 45° profile angle

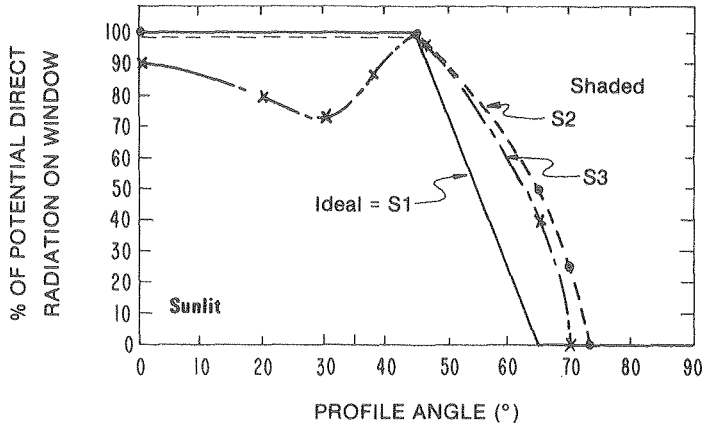

(a)

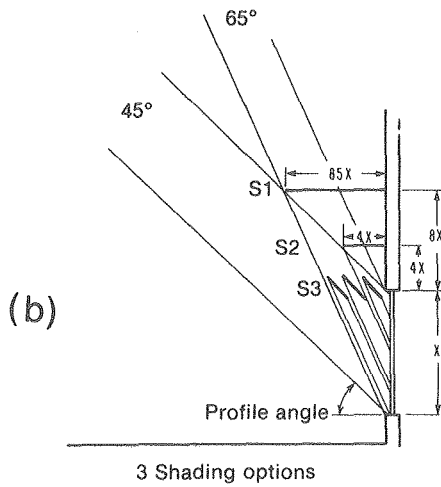

(b)

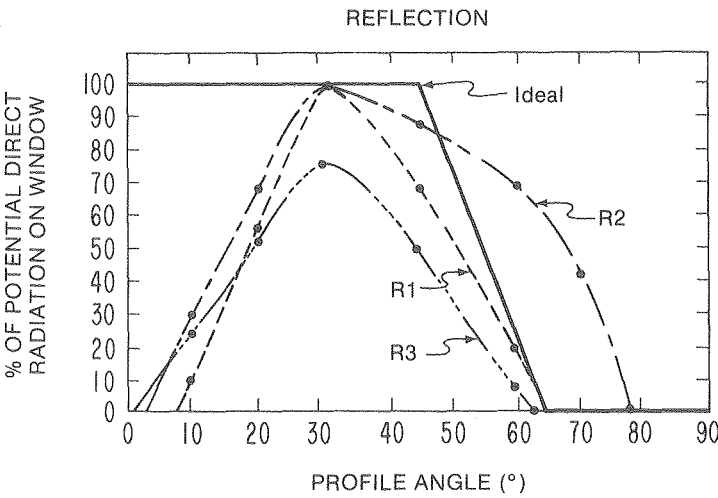

(c)

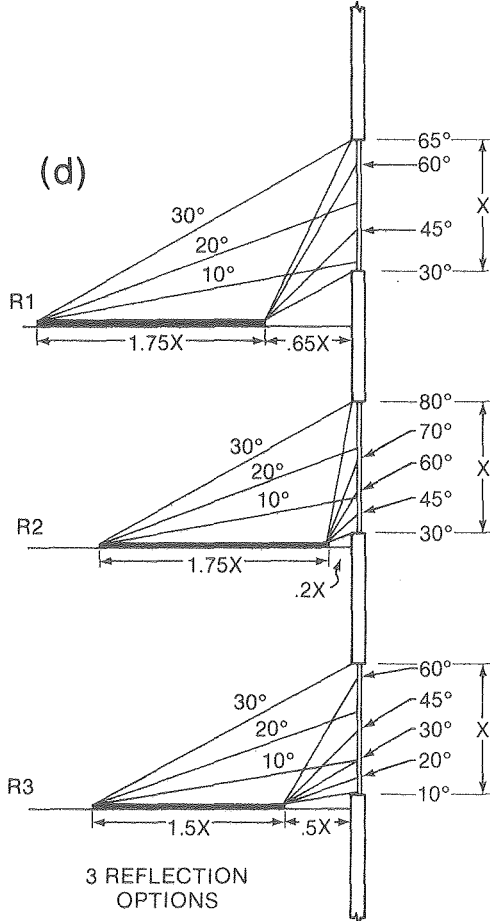
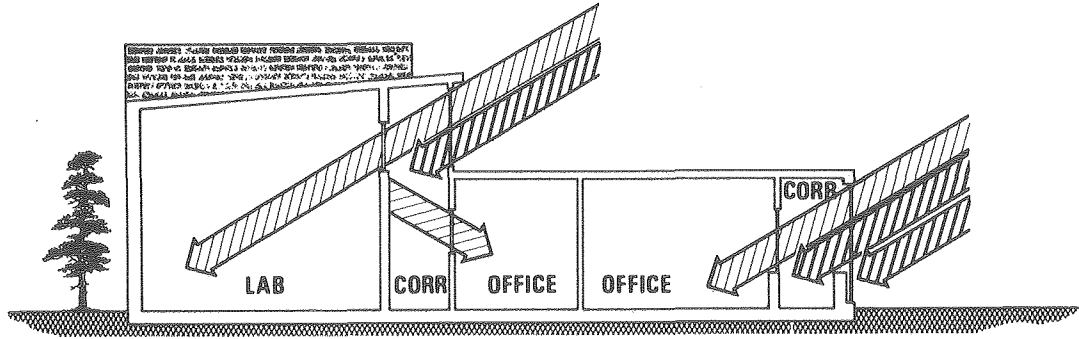

FIGURE 5:

SHADE AND REFLECTOR DESIGN.

### Passive Design Evaluation and Refinement

The second passive solar alternative design is shown in Figures 6, 7, and 8. There is a preponderance of south-facing glazing. As in the first passive design, corridors accept the solar gains and act as buffers to occupied spaces. This design has the same floor area, functional organization, structural system, and materials as the original design.



SUN ENTRY: NOON, MID-JANUARY

XBL 798-10756

FIGURE 6: SECTION — PASSIVE DESIGN.

Quantification of the energy impacts of various changes is needed to answer two questions: is the passive design an improvement over the original?; and what changes will prove beneficial to the thermal performance of the basic passive design? The computer program DOE-1 (3) was used to evaluate building thermal performance. DOE-1 is a building energy analysis program similar to BLAST, with the added capability of modeling zone-to-zone heat transfer. This capability is critical in accounting for interaction between halls and occupied spaces. Fig. 9 presents DOE-1 evaluations of the architectural and control changes which prove beneficial in reducing the total annual heating and cooling load. Without such an evaluative tool, some important improvements might have been missed.

The thermal evaluation strategy started with the original design. Changes were made, one by one, and ineffective ones discarded. The building was divided into four zones: offices, labs, and the south and central halls. This allowed the use of different control strategies in the corridors, where temperatures would float in response to the solar gains and conductive losses associated with large glazing areas. The first DOE-1 run (Col. 1 of Fig. 9) modeled the original design of the contracted A/E firm. Schedules were provided to account for predicted thermal effects of occupants, lights, equipment, and infiltration. Thermostats were set at 78°F for cooling and 68°F for heating, with a 60°F night heating setpoint. This base run resulted in an annual heating load of 328 MBTU and an annual cooling load of 17 MBTU, totalling 345 MBTU. (Throughout the remainder of the paper we will indicate loads in an abbreviated format, (328 + 14 = 345), indicating heating, cooling, and total loads respectively, in MBTU.)

The first and most obvious improvement was made by increasing the insulation level in the walls. The U-value was reduced from 0.27 to 0.08

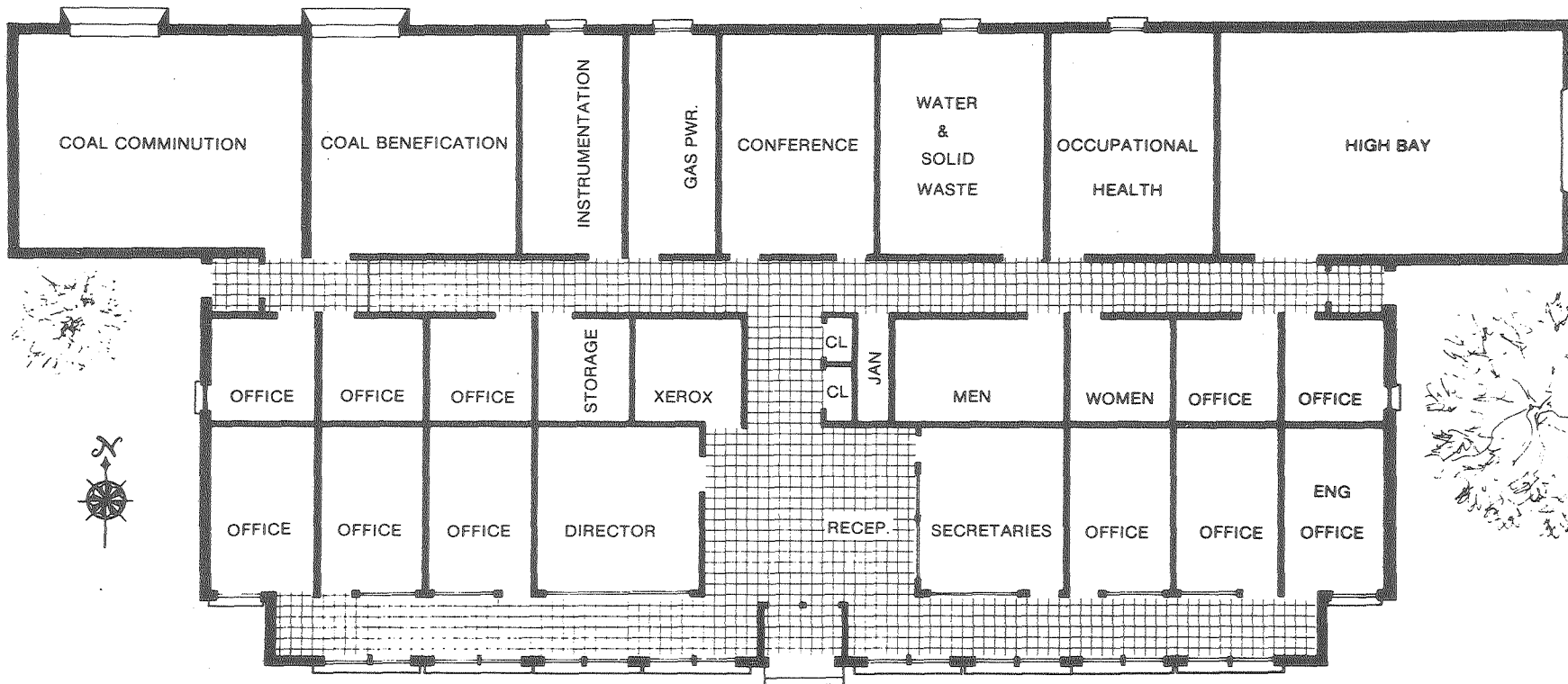

FIGURE 7: PLAN — PASSIVE DESIGN.

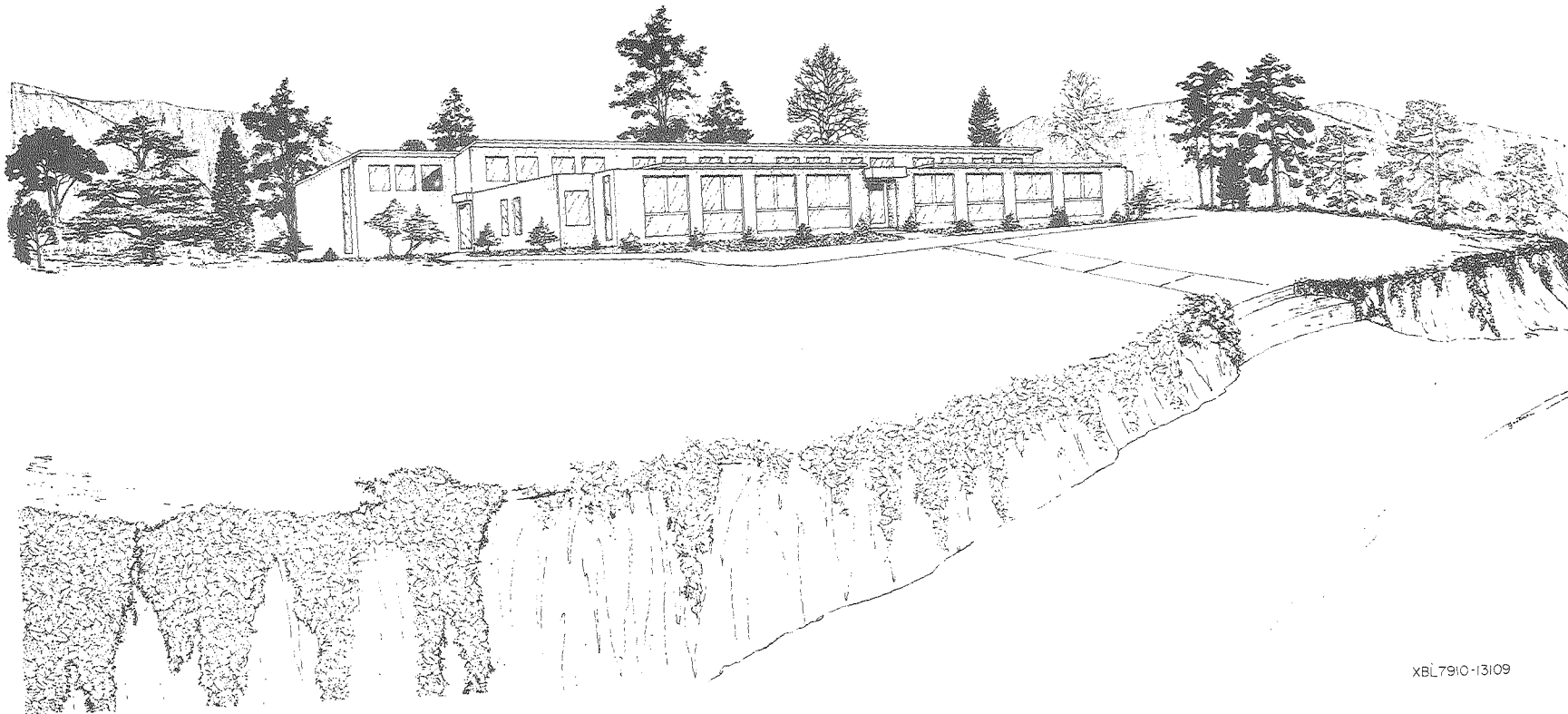

FIGURE 8: PERSPECTIVE — PASSIVE DESIGN

XBL7910-13109

BTU/hr ft<sup>2</sup> °F. Predictably, that was the most important change, dropping the loads to (216 + 18 = 234, Col. 2 of Fig. 9). Next, thermostatic controls for the hallways were expanded from the 68-78°F range to settings of 60-90°F. Because the corridors have only transient use, the effect on occupant comfort is minimal. In itself, this change had little impact; its significance lay in preparation for the passive driving force -- solar gain. When the solar load is added these zones require more flexibility. Incorporation of 1300 ft<sup>2</sup> of south-facing glazing (with shading) lowered the total load substantially (163 + 39 = 202, Col. 4).

Although the annual heating load was reduced 25% by the glazing modifications, the cooling load was more than doubled, detracting seriously from the effectiveness of the new design. Two options which could be installed each year for the duration of the cooling season were examined. Doubling the width of the overhangs reduced the cooling load from 39 to 32 MBTU. On the other hand, the load was lowered to 22 MBTU by insulating 70% of the south windows during the summer, leaving the remainder for daylighting and view (Col. 5). The same insulating shutters could also be used for night insulation in winter. Because no effective analysis technique for night insulation was available, hand calculations were performed after all other changes had been made.

Assessments were made for several other building alterations. An increase in mass, from 75 to 125 lb/ft<sup>2</sup>, resulted in load reductions which are probably too small to justify the effort (Col. 6). To reduce the substantial heating load in the laboratory zone, the windows in the central hall were moved back to allow direct solar gain in the labs. The resulting decrease in heating load was matched by an increased cooling load. The decision on window placement can therefore be made strictly on architectural grounds. However, increasing lab/central hall window area from 500 to 800 ft<sup>2</sup> was effective at reducing the total load (Col. 7). Finally, the effect of an earth berm placed against the north wall was minor, and probably not worth the practical problems involved in berming.

By incorporating the useful products of this "thermal tuning" process, (summer window insulation, extra windows, more mass), the loads were reduced significantly. After the basic passive system was added, the loads were (163 + 39 = 202, Col. 4), the tuning process reduced them to (142 + 24 = 166, Col. 7), an 18% reduction in total load. The improvements during this design step benefited most from the evaluative tool. Without such a program, ineffective modifications would have been made, and useful ones would have been missed.

Hand calculations were performed to determine the benefits of night insulation in a dynamic thermal situation. Reductions resulted in final loads of (112 + 24 = 136, Col. 8).

The total load of the tuned redesign was only 58% of the load after the substantial improvement to the wall insulation (Col. 2), and 39% of the original design (Col. 1). The energy impact is undoubtedly larger than the thermal loads alone would indicate, since no account has been taken of the benefits of daylighting.

The usefulness of an evaluation tool for this design has been demonstrated, but the form of such a tool is very important. Simple techniques are effective for component calculations and basic design decisions, but they become unwieldy when applied to whole buildings and

PROGRESSION OF SUCCESSFUL  
ENERGY-REDUCING CHANGES,  
EVALUATED USING DOE-1.

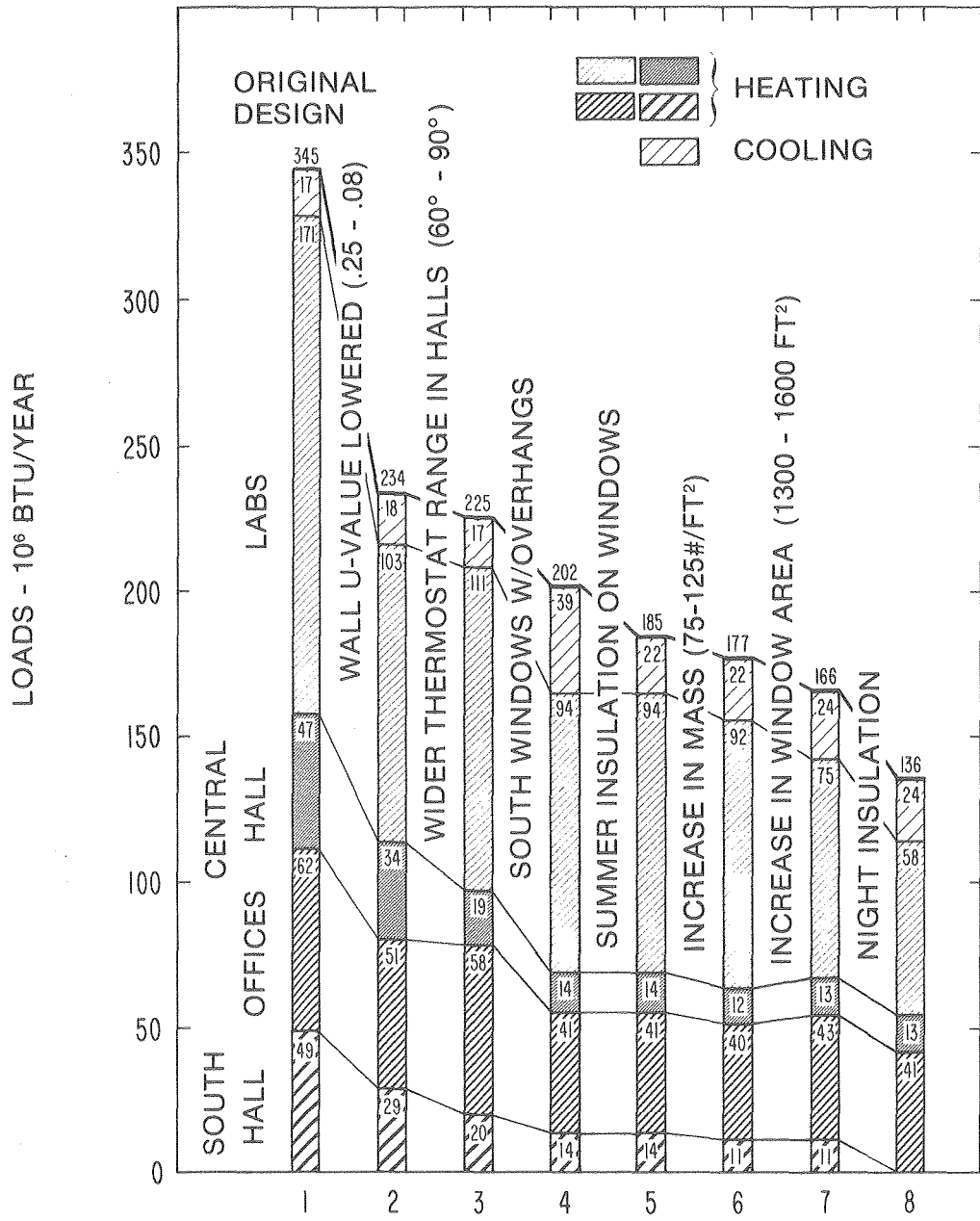

XBL 798-10757

FIGURE 9: BUILDING ENERGY ANALYSIS.



dynamic thermal effects so important in passive solar designs. Computer models such as the ones used on this project can generate useful answers, but there are four major drawbacks to current programs:

- they are not able to model any but the simplest passive configurations;
- they do not account for energy savings from daylighting, which are potentially large;
- they are not generally accessible to the occasional user; and
- they are unwieldy, input is too time consuming, and many results require a great deal of interpretation.

#### SUMMARY

Passive solar design is an integral part of the architectural design process. Unfortunately, special information required in the process is not presently accessible to most architects. In this case study, specialized tools and an uncommon amount of time were available to produce a simple passive design which will save substantial energy. Architects will require tools which are more accessible, more comprehensive, and faster and easier to use. This study suggests three ways in which better tools can be produced:

- (1) better methods of measuring, gathering, and reporting data, especially for weather;
- (2) use of computer programs (energy analysis programs and specialized data manipulation programs) to generate tables and graphs, such as those suggested for window evaluation and shading design; and
- (3) development of building energy analysis programs which can evaluate the thermal and daylighting performance of passive solar designs, and which respond to the architect's limited time and expertise to devote to energy.

More and more passive solar buildings will be built in the coming years. Their design will fall to architects who are not now aware of the many factors which must be considered to produce such a building. They must be provided with new and better tools to enhance the possibility of successful designs.

#### REFERENCES

- (1) Facilities General Design Guidelines Handbook, Appendix 6301, ERDA, 1977.
- (2) The National Climatic Atlas, U. S. Dept. of Commerce, N.O.A.A. (National Climatic Center, Asheville), 1977 and the Weather Almanac, James Ruffner and Frank Bair (Gale Research Co., Detroit), 1977 are two good general sources.
- (3) DoE-1 is a public domain program developed at Lawrence Berkeley Laboratory, supported by the DoE Office of Conservation and Solar Applications.

This report was done with support from the Department of Energy. Any conclusions or opinions expressed in this report represent solely those of the author(s) and not necessarily those of The Regents of the University of California, the Lawrence Berkeley Laboratory or the Department of Energy.

Reference to a company or product name does not imply approval or recommendation of the product by the University of California or the U.S. Department of Energy to the exclusion of others that may be suitable.

TECHNICAL INFORMATION DEPARTMENT  
LAWRENCE BERKELEY LABORATORY  
UNIVERSITY OF CALIFORNIA  
BERKELEY, CALIFORNIA 94720