

Lawrence Berkeley National Laboratory

Recent Work

Title

A 30-INCH PROPANE BUBBLE CHAMBER

Permalink

<https://escholarship.org/uc/item/6z07q299>

Authors

Powell, Wilson M.
Fowler, Willaim B.
Oswald, Larry O.

Publication Date

1958-05-09

UNIVERSITY OF
CALIFORNIA

*Radiation
Laboratory*

TWO-WEEK LOAN COPY

*This is a Library Circulating Copy
which may be borrowed for two weeks.
For a personal retention copy, call
Tech. Info. Division, Ext. 5545*

BERKELEY, CALIFORNIA

DISCLAIMER

This document was prepared as an account of work sponsored by the United States Government. While this document is believed to contain correct information, neither the United States Government nor any agency thereof, nor the Regents of the University of California, nor any of their employees, makes any warranty, express or implied, or assumes any legal responsibility for the accuracy, completeness, or usefulness of any information, apparatus, product, or process disclosed, or represents that its use would not infringe privately owned rights. Reference herein to any specific commercial product, process, or service by its trade name, trademark, manufacturer, or otherwise, does not necessarily constitute or imply its endorsement, recommendation, or favoring by the United States Government or any agency thereof, or the Regents of the University of California. The views and opinions of authors expressed herein do not necessarily state or reflect those of the United States Government or any agency thereof or the Regents of the University of California.

UCRL-8277

UNIVERSITY OF CALIFORNIA

Radiation Laboratory
Berkeley, California

Contract No. W-7405-eng-48

A 30-INCH PROPANE BUBBLE CHAMBER

Wilson M. Powell, William B. Fowler, and Larry O. Oswald

May 9, 1958

Printed for the U. S. Atomic Energy Commission

This report was prepared as an account of Government sponsored work. Neither the United States, nor the Commission, nor any person acting on behalf of the Commission:

- A. Makes any warranty or representation, express or implied, with respect to the accuracy, completeness, or usefulness of the information contained in this report, or that the use of any information, apparatus, method, or process disclosed in this report may not infringe privately owned rights; or
- B. Assumes any liabilities with respect to the use of, or for damages resulting from the use of any information, apparatus, method, or process disclosed in this report.

As used in the above, "person acting on behalf of the Commission" includes any employee or contractor of the Commission to the extent that such employee or contractor prepares, handles or distributes, or provides access to, any information pursuant to his employment or contract with the Commission.

A 30-INCH PROPANE BUBBLE CHAMBER

Wilson M. Powell, William B. Fowler, and Larry O. Oswald

Radiation Laboratory and Department of Physics
University of California, Berkeley, California

May 9, 1958

ABSTRACT

A propane bubble chamber with a sensitive volume of 30-1/2 in. by 21-1/2 in. by 6-1/2 in. deep operating in a magnetic field of 14,000 gauss is described. Operating parameters and some engineering details are given. The part of the chamber containing the propane is hydrostatically supported in oil through which the chamber is photographed. This permits the use of small glass windows with a large safety factor.

A 30-INCH PROPANE BUBBLE CHAMBER*

Wilson M. Powell, William B. Fowler, and Larry O. Oswald

Radiation Laboratory and Department of Physics,
University of California, Berkeley, California

May 9, 1958

INTRODUCTION

Propane bubble chambers¹ operate at pressures of nearly 400 psi and temperatures about 60°C. The high pressure makes it impossible to use a glass window of much more than seven inches in diameter and at the same time to have a safety factor of 15 such as is used on ship portholes. The chamber described here overcomes this difficulty by immersing the propane container in mineral oil which is contained at the high pressure in a steel tank. The chamber is viewed through four 2-in. -diam. by 1 1/2-in. -thick glass windows in the top of the tank. The safety factor of these windows is over 15.

APPARATUS

The Chamber X

Figure 1 shows the chamber. Its external dimensions were designed to permit it to fit into a large electromagnet which provides a steady magnetic field of 13,000 gauss over the volume of the propane.

The part containing the propane in Fig. 1, consists of an oval stainless steel chamber 31-1/2 in. long by 21-1/2 in. wide by 6-1/2 in. deep with the ends curved in a 10-3/4 in. radius. Glass windows (5) 3/8 in. -thick form the top

*This work was supported by the U. S. Atomic Energy Commission.

¹D. A. Glaser and D. C. Rahm, Phys. Rev. 97, 474 (1955), and
Larry O. Oswald, Rev. Sci. Instr. 28, 80 (1957).

and bottom of the chamber. The upper glass is held by a clamping ring which is sealed to the sidewall of the chamber by a flexible Hycar rubber diaphragm c which permits the glass to move vertically one inch. The stainless steel rod d is attached to the clamping ring rigidly and is constrained in its motion by the two sliding ball bearings e, so as to maintain the top glass parallel to the bottom glass during its vertical motion.

In filling the chamber, both the propane container and the outer space as well as the space behind the Hycar diaphragm are evacuated (see below). In order to reduce the amount of foreign matter reaching the chambers, the propane is distilled into the chamber by heating the propane bottle. The propane fill tube is shown at n. A rectipot connected to the top glass gives an indication of its vertical position. A differential pressure of 2 psi will not rupture the propane container. Standard grade-3 white oil is introduced at the top of the outer container with the vacuum pumps still running. As soon as oil covers the top glass, the weight of the oil presses the top glass downward. When this happens, propane vapor is introduced until the glass rises to the middle of its range of motion. This process is continued until the chamber is filled with oil. Then, on the introduction of propane gas and liquid, the top glass is held in the middle position by the oil.

Expansion Mechanism

A cylindrical Hycar rubber diaphragm f at the top of the outer container is pressed against a cylindrical-hole plate with 4000 1/16-in. - diam. holes leading to the manifold, where eight exhaust ports lead to eight Barksdale valves, which are equally spaced around the container. One of these is shown at g, Fig. 1. The chamber is compressed by opening the Barksdale valves to an external tank containing nitrogen at 390 psig. The top glass moves down, squeezing out the bubble of propane gas above the liquid. Therefore the compressed position is determined by the propane volume and the recompression pressure. When an expansion is made, the Barksdale valves are opened to a reservoir of nitrogen at 5 psig. The chamber is fully expanded after 45 milliseconds (msec), and recompresses in about the same time. The top glass of the

chamber moves about 0.2 in. Figure 2 shows the signals from the transducer which measures the pressure as the solid strips and those from the rectipot which indicates the position of the top glass, as wiggly lines. The transducer is located at h in Fig. 1.

The operation of the chamber results in a sensitive time of at least 4 msec and the lights are flashed from 2 to 6 msec after the arrival of the beam.

Illumination

Thirteen flash tubes (i, Fig. 1) beneath the chamber supply the illumination. Alternate lights are flashed leaving the other set as spares. All surfaces around the lights are painted white and a screen that transmits about half the light is placed over each flash tube to reduce the intensity directly over each tube. Just above the tubes is a sheet of opal glass j, to diffuse the light. Between the opal glass and the bottom glass of the chamber is a light collimator k, called a "venetian blind", which directs the light entering the chamber away from the two viewing ports l, so that the bubbles appear against a dark background. The "venetian blind" consists of 3/4-in. - wide strips 1/16-in. -thick Lucite tilted so that their edges point at an angle of 20° away from the viewing ports l, through which the photographs are taken.

These strips are cemented together with black cement so as to form a solid sheet 3/4 in. thick covering the bottom of the chamber, all strips being aimed properly so that the light misses the lenses. If these strips were continuous along their length, one end of the chamber would not be illuminated. In order to overcome this difficulty the 3/4-in. solid sheet was cut into 3/4-in. - wide strips perpendicular to the sheets, and alternate strips were oriented in the opposite way so that both ends of the chamber received equal illumination, though somewhat reduced from that at the center. The end lights are increased in intensity to compensate for this.

Photography

The set of 6 or 7 flash tubes were flashed at 1700 v with 32 μ f with the end tubes at about 1900 v. Photographs were taken at an f number of 16, through a Wratten G25 red filter, using Eastman Linagraph Panchromatic, 70-mm film. The red filter was used to reduce the effect of chromatic aberration in the oil. The lenses were matched golden wide-field Dagor of 4-3/8 in. focal length. Two separate cameras holding 1000 ft of film each and 9 in. apart gave pairs of pictures at a demagnification of about 7. Fiducial marks on the top and bottom glass consisted of dots on a 5-cm grid.

Between the two cameras mounted on the top of the chamber there is a data box containing a magnet ammeter, run description, and the picture number in neon lights. A duplicate set of lights displays the picture number at the console. A second lens pointing out of the back of each camera photographs the data box.

The cameras operate in a magnetic field of 700 gauss and therefore all controls are operated by air or vacuum. The film is pressed against a flat backing plate by a frame which holds the edges down. The backing plate is covered with fine grooves which are evacuated so as to hold the film flat.

Temperature Control

Two independent hot water systems are used to heat the oil, one for the space above the propane chamber, and one for the space below. The temperature of the water below is hotter by 5 C^o than that above so as to maintain a uniform sensitivity from top to bottom of the propane.

The water tubes below the chamber enter at p, Fig. 1, and run back and forth between the lights. The water tubes for the upper part of the oil container are soldered to 1/16-in. copper sheets (u) which are between the tubes and the steel walls. The copper sheets are separated from the walls by 6-mil-thick Mylar sheets at v to give some heat insulation. The tubes are then covered with 1/2-in. -thick polyurethane sponge w, and this is held down by another 1/16-in. copper sheet x which presses the sponge down on the tubes and makes it fill the spaces between the tubes. This prevents oil convection around the water tubes, and the inner copper sheet reduces azimuthal variations in temperature of the oil.

Additional heating is provided at the top of the oil container by flowing water from the upper system through water tubes around the top cover plate. Because the base of the oil container can transfer heat through the bottom to the magnet, a similar water tube, is supplied by the lower hot water system.

Beam Window

The various beams of particles enter along the long axis of the chamber through a 1/8-in. -thick by 2-in. -high by 9-in. wide stainless steel window shown at y, Fig. 1. The beam passes through 1-in. of oil and then through the 1/8-in. stainless steel wall of the propane chamber. The tracks can be seen over the full 30-in. length.

Electrical Connections

All electrical connections enter the outer container through the right side wall where the propane chamber is narrowest. There are altogether 50 feed-throughs to take care of the lights, transducer, and two rectipot. The thermocouple which measures the temperature of the propane is inserted at m.

Figure 3 is a photograph of the control console, which contains the following items: 1. Two oscilloscopes for observing rectipot signals, transducer signals, time pips supplied by the Bevatron, and flashing time of the lights; 2. Micromax for observing temperatures of the water systems and the propane; 3. Automatic alarms for a great variety of functions; 4. Camera-wind controls; 5. Water-heater switches; 6. Nitrogen-compressor controls; 7. Propane-bottle heater control; 8. Gate and delay circuits for expansion, recompression, lights, camera wind, number counter, etc; 9. Picture number.

The Magnetic Field

Figure ³/~~4~~ shows the chamber in the magnet. The bottom slab of iron (a) measures 5 ft 8 in. square by 8 in. thick. To this is attached the bottom coil consisting of 192.5 turns of 0.640-in. -square copper tubing with a 0.402-in. -diam. hole for water cooling. This coil is attached to plate a and wound on an iron cylinder 40 in. o.d. and 37.5 in. i. d.

A cylinder of iron (c) 37.4 in. o. d. and 15 in. high fits inside the coil, and the oil container sits on top of it in such a position that the inside surface of the 4-in. -thick bottom of the oil container is on the same level as the top of the iron ring upon which the bottom coil is wound.

Four iron posts (d) support the top iron slab (e) to which the upper coil (f) is attached. The oil container passes through a 22-in. -diam. hole in the top slab e.

The oil container itself is made entirely of magnetic steel except for the vertical 2-in. -thick wall of the bottom portion(t, Fig. 1.) which is made of nonmagnetic steel.

The upper part of the oil container acts as the upper pole of the magnet and the bottom of the oil container forms part of the lower pole.

Fourteen iron return paths (g, Fig. 2) measuring 6 ft by 10 in. square, can be attached around the four sides between the upper and lower iron slabs according to the needs of the experiment, leaving appropriate vacancies for the entering beam and water and electrical leads.

Figure ⁴/~~5~~ shows a plot of the magnetic field against radius. The three curves give the fields for three different heights in the propane chamber.

Oil-Cleaning System

The Hycar rubber diaphragm colors the supporting oil gradually, and it is necessary to clean the oil once a day. This is accomplished by passing the oil through an oil press of the type used for filtering transformer oil. The press is loaded with about 1/2 lb of Fullers earth which is mixed with oil. This loaded oil is passed through the filter to charge it. Then the chamber oil is removed in small amounts, and replaced by filtered oil under sufficient pressure. One hundred gal. of oil can be introduced in this way in 2 hrs time.

DISCUSSION

Safety Precautions

Sixteen gallons of propane are needed to fill the chamber, and in the event of a fire in the building, provision has been made to get the propane out of the chamber in 25 min. A steel pipe leads the propane to a mixer which consists of a continuously operating air-driven blower outside the building. This blower mixes the propane with air to a concentration of 1.5%. A standby supply of compressed nitrogen turns on automatically if the fire interrupts the compressed air to the blower motor.

The chamber is compressed with nitrogen, which is recirculated. In case of a diaphragm failure, the propane enters this closed system, which automatically dumps the propane through the blower. Oil which might come along with the propane separates out in a 150-gal propane tank, used in the nitrogen-recirculating system. If the inner propane chamber should rupture, the propane would mix with the oil. A test of this mixture showed that the propane vapor pressure dropped from 340 lbs to 190 lbs when mixed with the oil. All parts of the system were tested over a 12-hr period at 2.5 times operating pressures, and at the 60° operating temperature. These tests are repeated whenever electrical lead-throughs are changed.

Chamber Operation

Expansions are made every 6 sec, being initiated by a signal from the Bevatron some 45 msec before the arrival of the beam. The lights are flashed by counters only when a beam of the proper intensity enters the chamber. About 2.3 ft³ of nitrogen at atmospheric pressure is used for each expansion. This is supplied at a pressure of 500 psi, and suitably reduced in pressure to match the temperature of the propane. At 61°C, the compressed pressure is about 390 psi. The rubber diaphragm has operated without failure for several hundred thousand expansions and shows no signs of deterioration.

The number of bubbles per unit length of track can be increased or decreased depending on the demands of the experiment. A top glass motion of 0.2 in. produces very closely spaced bubbles. Care must be taken to keep

the overpressure not more than 25 psi above the vapor pressure. Below this point, a bubble forms, above this point tracks become very faint.

During a run when antiprotons stopped in the chamber and it was desirable to detect them by ionization when they had a kinetic energy of 200 Mev and an ionization of 1.9 times minimum, the best conditions were achieved when the temperature was 61 C^o, the overpressure was 25 psi, and the motion of the top glass was 0.1 in. A photograph taken under these conditions is shown in Fig. 6. The comparison of various ionizations can be made. The background consists of 90% μ mesons with 750 Mev/c momentum. The antiproton entering at a has an ionization of 1.9 times minimum. The antiproton charge-exchanges, and the resulting antineutron star below shows five minimum ionizing tracks.

Faults of the Chamber

At the moment of writing there is one outstanding problem in the operation of the chamber, which has more than one obvious solution. The hot-water pipes beneath the chamber produce convection currents in the oil, particularly along the narrow sides of the propane container. These currents of warmer oil flow up into the region over the chamber and, because of the different density and consequent change in index of refraction of the oil, produce irregular blurring in parts of the chamber. These may be reduced by putting baffles between the top of the propane container and the sidewalls of the oil container. They also may be reduced by filling much of the space above the chamber with Lucite. Experiments are under way to test the effectiveness of the various possibilities.

Difficulties with the lights has arisen from breaking of the leads inside the caps of the flash tubes, and of the wires leading to the flash tubes. All of these points are subject to sudden impulsive shocks due to the current in the 14,000-gauss field. In order to reduce these failures, leads are being more firmly soldered to the caps, and heavier wires are being used.

Characteristics of the Chamber

The density of the propane, when the chamber is expanded, is approximately 1g/in. The radiation length for a gamma ray of infinite energy is 70 cm.

The chamber has been expanded nearly 500,000 times, and no major difficulty has been observed.

The chamber can be removed, cleaned, and replaced in 38 hrs, 8 hrs of which is required to distill in the propane and to heat the chamber to the operating temperature of 61°C.

Altogether, the operation of the chamber can be characterized by the fact that it has been expanded nearly 500,000 times, and no major difficulty has been observed.

ACKNOWLEDGMENTS

We are deeply indebted to the many people for the success of this project. Vincent Romano as mechanical engineer was responsible for all mechanical work. Donald Lundgren designed and supervised all the electrical work. Warren Chupp designed and helped build the oil and propane system, as well as many other details. William P. Carpender designed the hot-water system, the nitrogen-compressor system, and the propane-disposal system. Raleigh Ellisen of the Petaluma Senior High School and Zvi Danenberg of Abraham Lincoln High School in San Francisco, both worked with us in the most active time of assembly. Peter Newcomb and Wesley Smart contributed a great deal to the success of this project both during and after assembly.

Fig. 1. The 30-inch propane bubble chamber, showing (a) the propane container, (b) the glass windows, (c) flexible rubber diaphragm between side wall and top-glass clamping ring, (d) stainless steel guiding rod, (e) cylindrical ball bearings controlling the guiding rod, (f) cylindrical Hycar rubber diaphragm, (g) 3/4-in. Barksdale valve, (h) transducer for measuring the propane pressure, (i) one of the 13 flash tubes, (j) opal-glass diffuser, (k) venetian-blind light collimator, (l) two of the four viewing ports in the top of the chamber, (m) thermocouple for measuring the propane temperature, (n) propane fill tube, (p) water tubes under the chamber, (q) water tubes in the upper part of the oil container, (r) water tube around the top cover plate, (s) water tube around the bottom of the oil container, (t) nonmagnetic steel region, (u) copper sheet, (v) Mylar sheet, (w) polyurethane sponge, and (x) copper sheet.

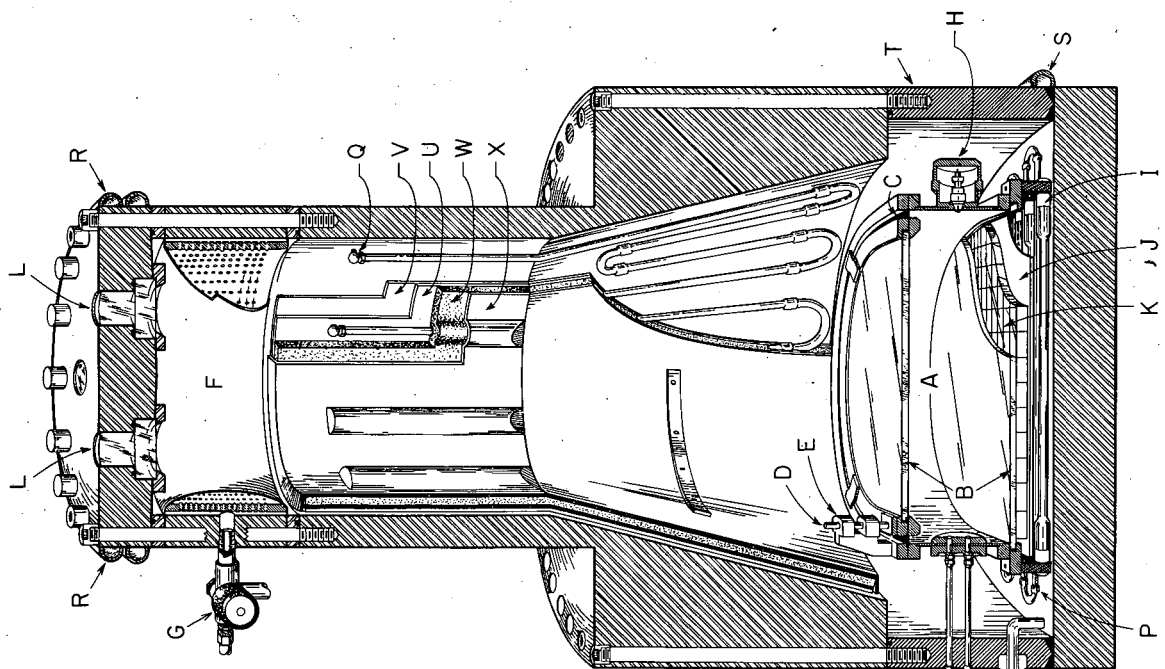

MU-15202

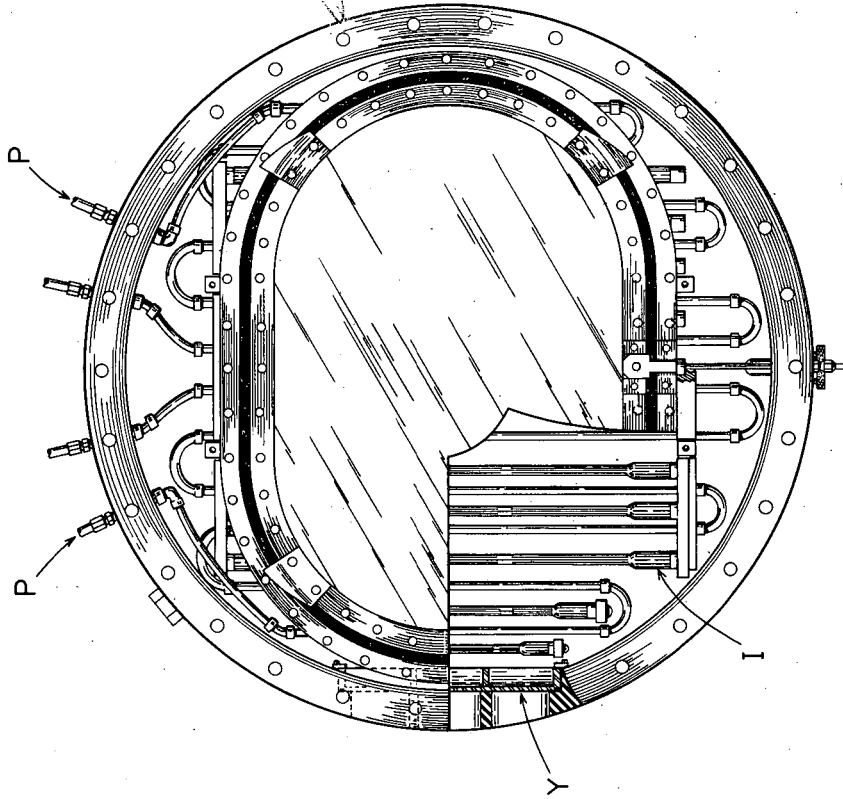

MU-15203

Fig. 1

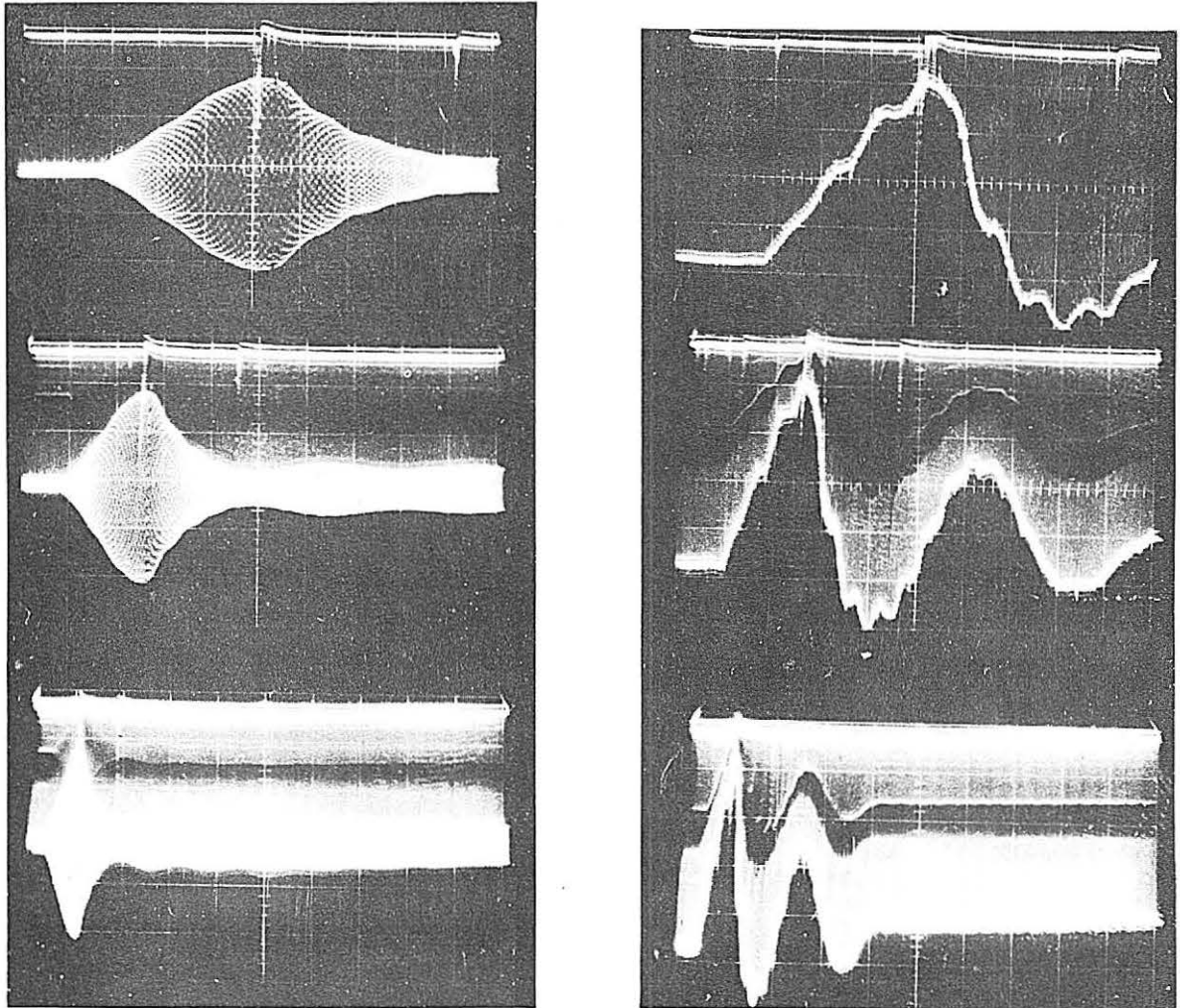

ZN-1931

Fig. 2. A. Transducer signal A and rectipot signal B. The top sweeps are 10 msec, the middle sweeps are 20 msec, and bottom sweeps are 50 msec.

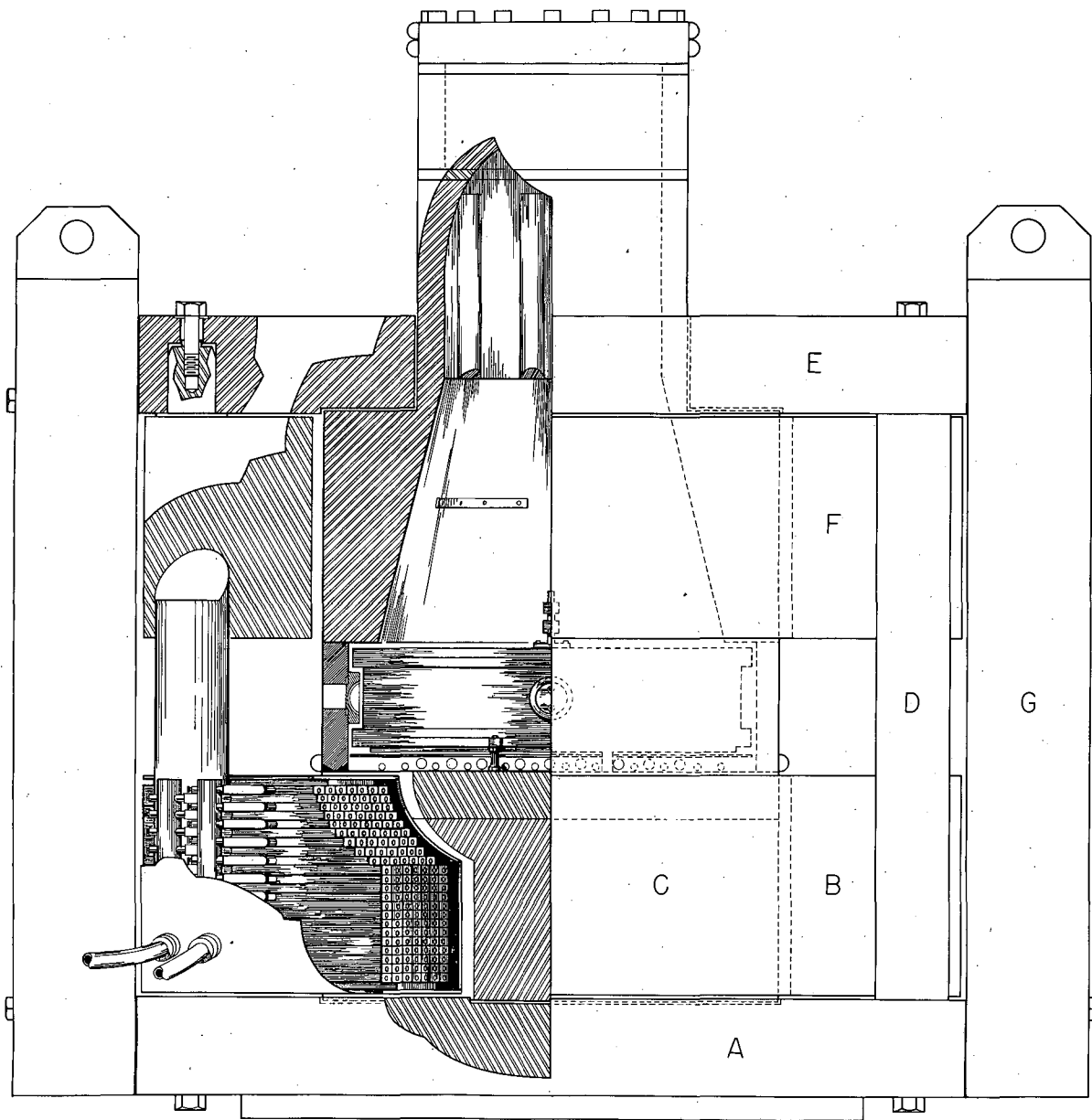

MUB-198

Fig. 3. The 30-inch propane bubble chamber in its magnet, showing (a) iron slab forming the bottom of the magnet, (b) bottom copper coil, (c) iron cylinder, (d) four iron posts supporting top slab E, (e) upper iron slab, (f) upper coil of the magnet, and (g) return paths.

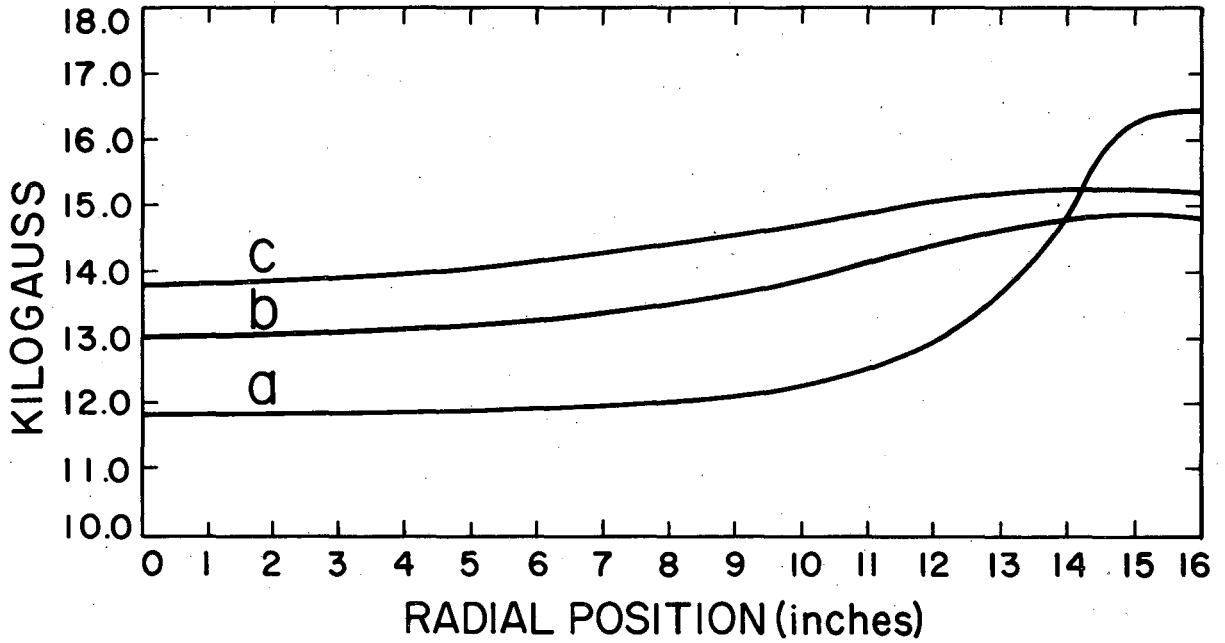

MU-15199

Fig. 4. Plot of the magnetic field with a magnet current of 1100 amp. The three curves are for (a) 3 in. above the median plane, (b) at the median plane, and (c) 3 in. below the median plane.

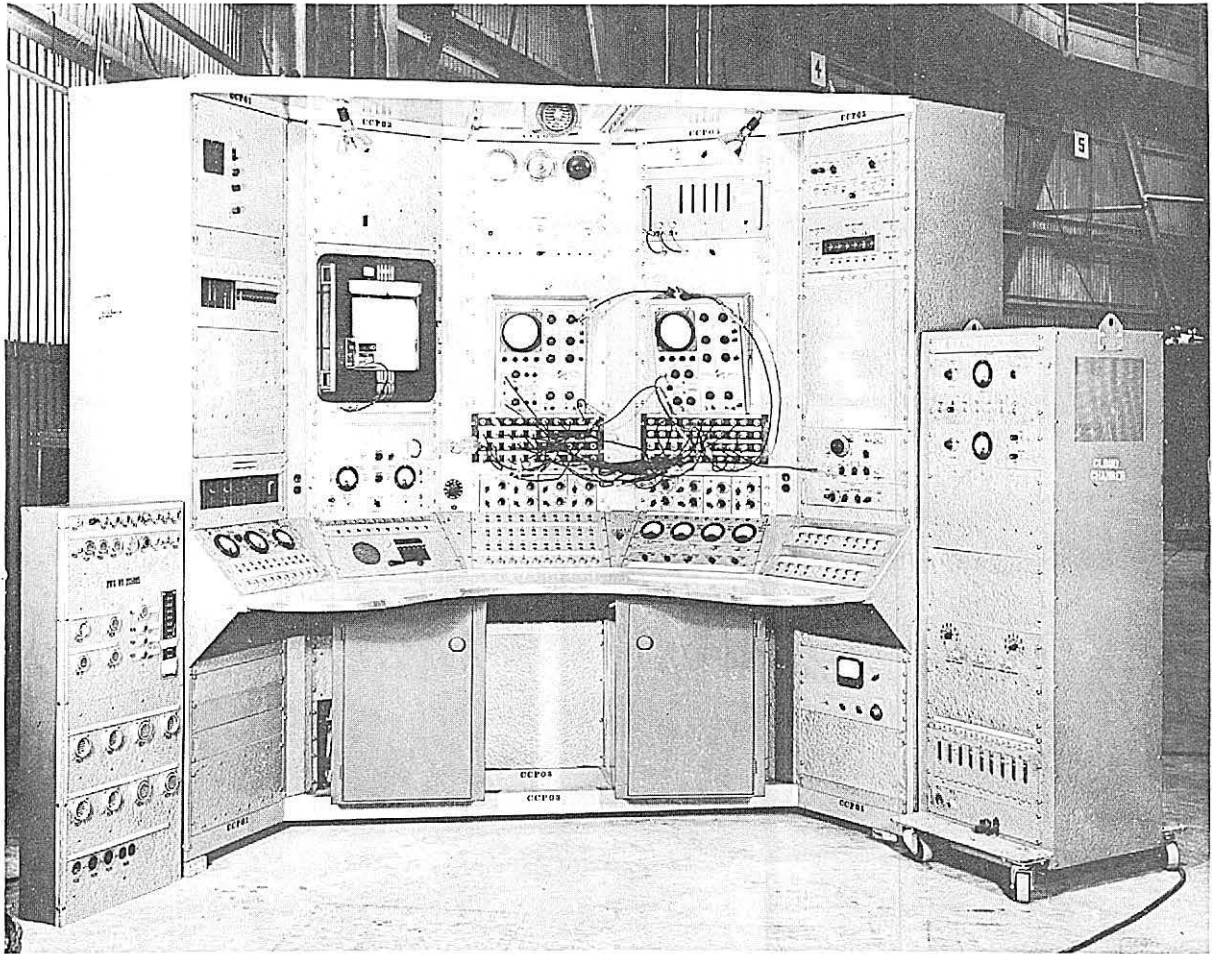

ZN-1933

Fig. 5. Photograph of the console.

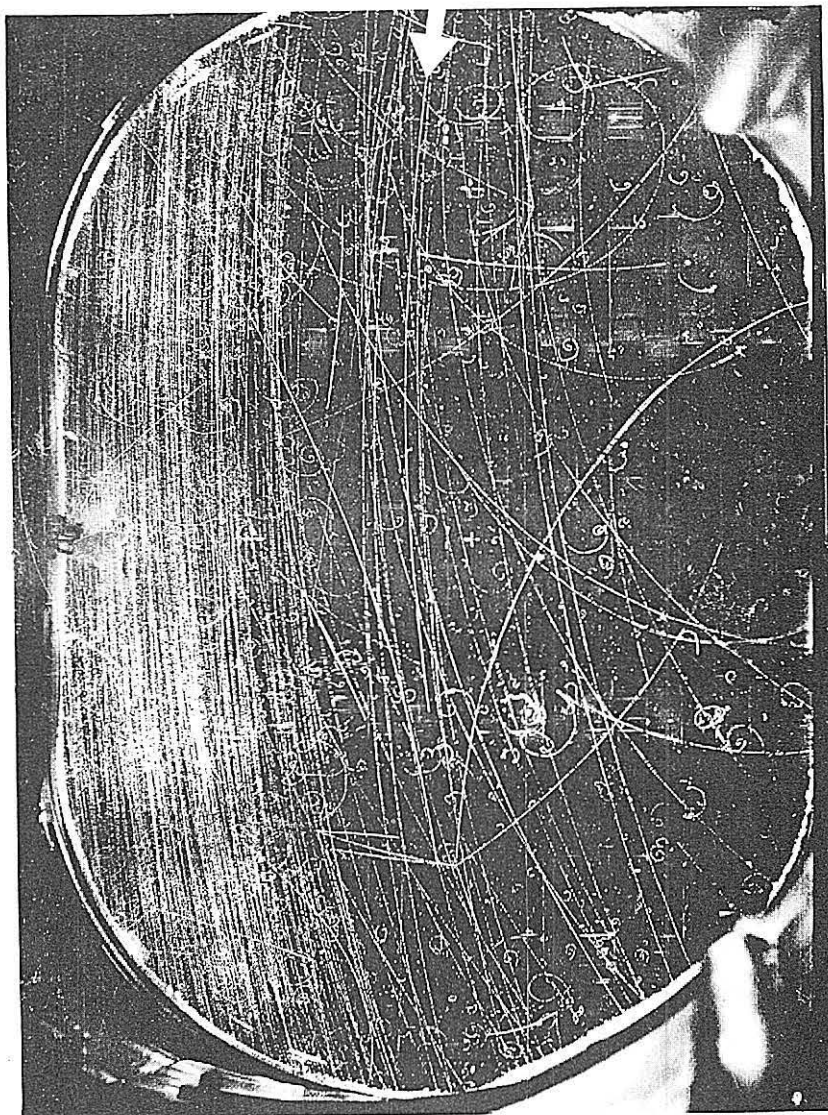

ZN-1932

Fig. 6. Photograph of an antiproton entering at the arrow with an ionization of 1.9 times minimum and charge exchanges at an energy of 50 ± 30 Mev. The 5-prong star below is produced by the annihilation of the resulting antineutron. All tracks of the star are at minimum ionization.