

# UC Berkeley

## UC Berkeley Previously Published Works

### Title

Titanium Imido Complexes by Displacement of  $-\text{SiMe}_3$  and C-H Bond Activation in a TIII Amido Complex, Promoted by a Cyclic (Alkyl)(Amino) Carbene (cAAC)

### Permalink

<https://escholarship.org/uc/item/6x64p2mk>

### Journal

European Journal of Inorganic Chemistry, 2017(18)

### ISSN

1434-1948

### Authors

Ye, Qing  
Ziegler, Micah S  
Lakshmi, KV  
[et al.](#)

### Publication Date

2017-05-10

### DOI

10.1002/ejic.201700295

Peer reviewed



Published in final edited form as:

*Eur J Inorg Chem.* 2017 May 10; 2017(18): 2484–2487. doi:10.1002/ejic.201700295.

## Titanium Imido Complexes *via* Displacement of $-\text{SiMe}_3$ and C–H Bond Activation in a Ti(III) Amido Complex, Promoted by a Cyclic (Alkyl)(Amino) Carbene (cAAC)

Qing Ye<sup>[a],[b]</sup>, Micah S. Ziegler<sup>[a]</sup>, K. V. Lakshmi<sup>[a],[c]</sup>, and T Don Tilley<sup>[a]</sup>

<sup>[a]</sup>Department of Chemistry, University of California, Berkeley, and Chemical Sciences Division, Lawrence Berkeley National Laboratory, CA94720-1460, USA

<sup>[b]</sup>Department of Chemistry, South University of Science and Technology of China, Shenzhen, Guangdong 518055 (China)

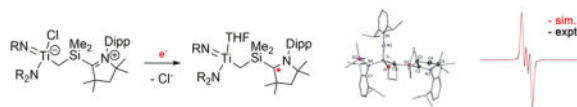
<sup>[c]</sup>Department of Chemistry and Chemical Biology and The Baruch '60 Center for Biochemical Solar Energy Research, Rensselaer Polytechnic Institute, Troy, NY 12180, United States

### Abstract

A strong  $\sigma$ -donating cyclic (alkyl)(amino) carbene (cAAC) triggers rearrangement of the silyl(aryl) amido ligand  $-\text{N}(\text{SiMe}_3)\text{Dipp}$  (Dipp = 2,6-diisopropylphenyl) in the coordination sphere of titanium(III) to afford a novel zwitterionic titanium imido complex with a  $\text{TiCH}_2\text{SiMe}_2[\text{cAAC}]$  linkage. Reduction of this species produces a new  $\text{DippN}=\text{Ti}$  imido complex containing a cAAC-centered radical species, characterized by single crystal diffraction analysis and electron paramagnetic resonance spectroscopy.

### Graphical Abstract

Herein we present the synthesis of a zwitterionic Ti(IV) imido complex and the isolation of a cAAC-centered radical by its single electron reduction



### Keywords

titanium; imido; silyl; radical; cAAC

### Introduction

Terminal imido transition metal complexes containing metal-nitrogen multiple bonds have been the focus of intense research because of their unique coordination and electronic properties,<sup>1</sup> as well as their involvement in catalysis and organic synthesis.<sup>2</sup> The formally

Correspondence to: T Don Tilley.

Supporting information for this article is given via a link at the end of the document.

dianionic (NR)<sup>2-</sup> ligand is isolobal with the cyclopentadiene anion,<sup>3</sup> and can act as a robust supporting ligand or as an active site in catalysis. While the imido chemistry of Group 5–8 transition metals was intensely studied in the 1980s,<sup>4</sup> the first well defined and structurally characterized terminal titanium imido complexes were independently reported in 1990 by Roesky et al.<sup>5</sup> and Rothwell et al.<sup>6</sup> Since then, titanium imido complexes have been shown to contain reactive M=N–R groups that can engage in catalysis (e.g. hydroamination<sup>7</sup> and ethylene polymerization<sup>8</sup>), and activate relatively inert bonds (e.g., alkyl and aryl C–H<sup>9</sup> and H–H bonds<sup>9c,10</sup>). In contrast to neutral  $\sigma$ -donor,  $\pi$ -acceptor ligands such as CO, which support metal centers in low to medium oxidation states, dianionic  $\sigma$ - and  $\pi$ -donating imido complexes are generally in high oxidation states.

Inspired by recent advances in the utilization of strong  $\sigma$ -donating and  $\pi$ -accepting cyclic (alkyl)(amino) carbenes (cAACs)<sup>11</sup> as ligands to stabilize highly reactive main group species, such as phosphorous and boron-based radicals, borylene (:BH), and the B $\equiv$ B fragment,<sup>12</sup> and unusually low-coordinate complexes M(cAAC)<sub>2</sub> (M = Au, Cu, Co, Fe, Ni, Mn, Zn),<sup>13</sup> attempts were made to synthesize low-valent titanium imido complexes supported by cAAC ligands.

In this context, two cAAC-triggered silylamido-to-imido transformations can be envisioned, namely a 1,2-elimination of halotriorganysilanes (**A** in Scheme 1), which has been applied to create M–E multiple bonds,<sup>14</sup> and a N–Si bond cleavage resulting from attack of cAAC at silicon<sup>15</sup> (**B** in Scheme 1). The –N(SiMe<sub>3</sub>)Dipp (Dipp = 2,6-diisopropylphenyl) ligand was chosen for stabilization of a low coordination number at titanium,<sup>16</sup> as well as for generation of a sterically protected Ti=N–Dipp fragment. Here, we report the synthesis and characterization of an unusual zwitterionic titanium imido complex (**3** in Scheme 2) upon reaction of a titanium(III) bis(amido) complex with cAAC (**2**, Scheme 1) *via* an unusual C–H activation process. The latter complex undergoes reduction to an alkyl complex containing a cAAC-centred radical (**4**, Scheme 2).

## Results and Discussion

The Ti(III) bis(amido) ate complex **1** was prepared as pale grey crystals in 41% yield from reaction of TiCl<sub>3</sub>(THF)<sub>3</sub><sup>17</sup> with 2 equivalents of LiN(SiMe<sub>3</sub>)Dipp in toluene. To generate a Ti(III) imido species, **1** was further treated with an equimolar amount of cAAC (**2**)<sup>18</sup> in toluene. A gradual color change from pale yellow to deep orange was observed over a period of 24 hours and then orange crystals were obtained upon workup of the reaction mixture. Notably, the <sup>1</sup>H NMR spectrum displayed peaks in the range of 0–7.5 ppm, suggesting that the isolated orange species contains diamagnetic Ti(IV) rather than paramagnetic Ti(III) (see SI).

Single crystals suitable for X-ray diffraction analysis were obtained upon recrystallization from toluene/pentane or THF/pentane. The molecular structure of this product (**3**; 17% yield) consists of an imido ligand with a nearly linear geometry at the N1 atom ( $\angle$ Ti–N1–C6 = 175.9(1)°) and a distinctly shortened Ti–N1 bond of 1.725(1) Å (cf. the Ti–N2 bond distance of 1.967(1) Å). This zwitterionic, formally Ti(IV) complex also contains chloride

and  $-N(\text{SiMe}_3)\text{Dipp}$  ligands and a highly unusual, formally cationic alkyl ligand bearing a pyrrolium group (Scheme 2, Figure 1).

The reaction to form **3** represents an example of pathway B in Scheme 1. A possible mechanism for this process (Scheme S1) involves  $\text{Me}_3\text{Si}$ -transfer to the strong cAAC donor to generate the ion pair  $[\text{Me}_3\text{Si-cAAC}]^+ \{[\text{Dipp}(\text{Me}_3\text{Si})\text{N}](\text{Cl})\text{Ti}=\text{NDipp}\}^-$ . Presumably, this transient, anionic Ti(III) imido species is quite reactive, and undergoes a C–H activation process by addition of a C–H group in the cation across the Ti=N bond. The resulting zwitterionic Ti(III) anilido alkyl complex,  $[\text{Dipp}(\text{Me}_3\text{Si})\text{N}](\text{Cl})\text{Ti}(\text{NHDipp})\{\text{CH}_2\text{SiMe}_2[\text{cAAC}]\}$ , then loses a hydrogen atom to produce the final, Ti(IV) imido product **3**. Note that analogous  $\text{sp}^3$ -hybridized C–H bond activations have been observed for transient Ti(IV) imido species  $(t\text{Bu}_3\text{SiO})_2\text{Ti}=\text{NSi}t\text{Bu}_3$  in the activation of methane.<sup>9b</sup> In addition, Mountford and co-workers have proposed a methyl C–H activation of  $\text{MeC}\equiv\text{CR}$  ( $\text{R} = \text{Me}$  or  $\text{Ph}$ ) by the Ti=N bond in  $\text{Ti}(\text{N}t\text{Bu})(\kappa^3\text{-N}_2\text{N}^{\text{py}})(\text{py})$  ( $\text{N}_2\text{N}^{\text{py}} = (2\text{-C}_5\text{H}_4\text{N})\text{CMe}(\text{CH}_2\text{NSiMe}_3)_2$ ) as the key step in formation of a four-membered azatitanacycle.<sup>19</sup> The loss of a hydrogen atom from the Ti(III)–NH(Dipp) unit is perhaps analogous to the oxidatively-induced  $\alpha$ -hydrogen abstraction utilized by Mindiola and coworkers in the synthesis of a Ti(IV) imido complex from a Ti(III) anilido precursor.<sup>20</sup> The nature of the hydrogen-transfer process is currently unknown, but the presence of hydrogenated free carbene,  $[\text{cAAC}]\text{H}_2$ , suggests that **2** is an H-acceptor in this process. The observation of  $\text{DippNH}_2$  as an additional side product suggests the operation of a competing, intermolecular H-transfer.

To further probe the nature of this reaction, the ratio of reactants **1** and **2** was varied from 1:1 to 1:2. These experiments showed that more than 1 equivalent of **2** is consumed, and the best yield (44%) was achieved at a ratio of ca. 1:1.5. The  $\text{DippNH}_2$  and  $[\text{cAAC}]\text{H}_2$  side products were identified by GC/MS analysis of the reaction mixture.

In addition to their established stabilizing effects, cAACs are of interest as redox-active ligands, resulting from their increased  $\pi$ -acidity in comparison with N-heterocyclic carbenes (NHCs). Thus, cAACs may accept an electron, intramolecularly from a low-valent center such as  $\text{Si}(0)$ <sup>21</sup> or  $\text{Cl}_2\text{Si}$ <sup>22</sup> to assume diradicaloid character in the resulting bis(cAAC) adducts (**I** and **II** in Scheme 3), or upon chemical reduction to allow isolation of stable ligand-centered carboxy<sup>23</sup> and pyridyl<sup>24</sup> radicals. From these perspectives, the zwitterionic complex **3** possesses two redox active sites, the cAAC ligand and the Ti(IV) metal center. Thus, the reduction of **3** might be expected to result in one of two types of structures, resulting from reduction of Ti(IV) or cAAC.

A THF solution of **3** was treated with an equimolar amount of sodium naphthalenide ( $\text{NaC}_{10}\text{H}_8$ ) at room temperature. After evaporation of the solvent under vacuum and extraction of the residue by pentane, red crystals of **4** suitable for X-ray diffraction analysis were obtained upon recrystallization from pentane/THF at  $-35^\circ\text{C}$ . As depicted in Figure 1, the overall tetrahedral geometry as well as the bond lengths around the Ti center, (i.e. Ti–N1, **4**: 1.736(2), **3**: 1.725(1) Å; Ti–N2, **4**: 1.963(2), **3**: 1.967(1) Å; Ti–C1, **4**: 2.150(2), **3**: 2.178(2) Å), are nearly identical to those of the precursor **3**, while the geometry about the carbene carbon centre C2 is notably affected by reduction. For example, the C2–N3 bond

distance is *ca.* 11 pm longer than the corresponding distance in **3**, while the C2–Si2 distance is decreased by *ca.* 11 pm. The C2–Si2 (1.872(2) Å) and C2–N3 (1.405(3) Å) bond distances are comparable to those of **I** and **II**. Moreover, the sum of angles about the C2 (357.0°) and N3 (356.7°) atoms resemble comparable parameters in **I** and **II** (Scheme 3), which indicates a slight deviation from trigonal-planar geometry and strongly suggests the presence of the C2-centered radical species **4** rather than a zwitterionic isomer with a Ti(III) center.

To probe the electronic structure of **4**, variable temperature X-band (9.6 GHz) electron paramagnetic resonance (EPR) spectroscopy measurements were performed on samples dissolved in toluene. The experimental EPR spectrum of **4** at room temperature (Figure 2; black trace) displays an isotropic signal centered at a *g* value of 2.00333 with pronounced line shape splittings due to the presence of electron-nuclear hyperfine interactions.

A spectral simulation of an unpaired electron spin ( $S = 1/2$ ) with electron-nuclear hyperfine interactions with single  $^{14}\text{N}$  (nuclear spin  $I = 1$ ),  $^{29}\text{Si}$  ( $I = 1/2$ ) and  $^{13}\text{C}$  ( $I = 1/2$ ) atoms provided an excellent fit (Figure 2; red trace, RMSD: 1.69%) of the experimental EPR spectrum of **4** at room temperature. Numerical simulation indicated that the intense peaks in the center of the EPR spectrum arise from the interaction of the electron spin ( $S = 1/2$ ) with the  $^{14}\text{N}$  ( $I = 1$ ) atom of **4** with a hyperfine coupling constant of 0.3772 mT. Moreover, the simulation indicated that the weaker peaks in the wings of the EPR spectrum (inset of Figure 2) result from interaction of the electron spin ( $S = 1/2$ ) with the  $^{29}\text{Si}$  and  $^{13}\text{C}$  atoms of **4**, with hyperfine coupling constants of 1.1386 mT and 2.7994 mT, respectively. The weaker intensity of the hyperfine peaks in the wings of the EPR spectrum is consistent with the lower natural abundance of  $^{29}\text{Si}$  ( $I = 1/2$ ) and  $^{13}\text{C}$  ( $I = 1/2$ ), 4.68% and 1.07%, respectively. Together, location of the EPR signal at  $g = 2.00333$  and the estimated hyperfine coupling constants strongly suggest that the unpaired electron is primarily ligand-centered, in agreement with analysis of the single crystal structure.

Similar EPR spectra were also obtained for a frozen solution of **4** in toluene. Variable temperature EPR spectra of **4** between 90 K and 160 K (Figures S1, S2) provide no evidence of reduction at the titanium center. While Ti(IV) is diamagnetic, Ti(III) is paramagnetic with a  $d^1$  electronic state that can often be observed by EPR spectroscopy, with signals usually located between  $g \sim 1.7$  and 2.0.<sup>25</sup> The observation of a broadened resonance that remains at  $g \sim 2$ , with no additional hyperfine detail such as coupling to spin-active Ti nuclei, further suggests that upon reduction of the zwitterionic complex **3** the electron is localized on the cAAC ligand.

## Conclusions

In summary, zwitterionic titanium imido complex **3** has been synthesized from a cyclic alkyl(amino) carbene-triggered rearrangement of a silyl(aryl) amido ligand in the coordination sphere of Ti. Furthermore, it is demonstrated that the zwitterionic species **3** would appear to possess two redox active sites but is reduced by an equimolar amount of sodium naphthalenide to afford the neutral cAAC-centered radical **4**, confirmed by the single crystal X-ray structure and X-band EPR spectroscopy.

Crystallographic data have been deposited with the Cambridge Crystallographic Data Center as supplementary publication no. CCDC-1491276 (1), CCDC-1491277 (3) and CCDC-1491278 (4). These data can be obtained free of charge from The Cambridge Crystallographic Data Center via [www.ccdc.cam.ac.uk/data\\_request/cif](http://www.ccdc.cam.ac.uk/data_request/cif).

## Supplementary Material

Refer to Web version on PubMed Central for supplementary material.

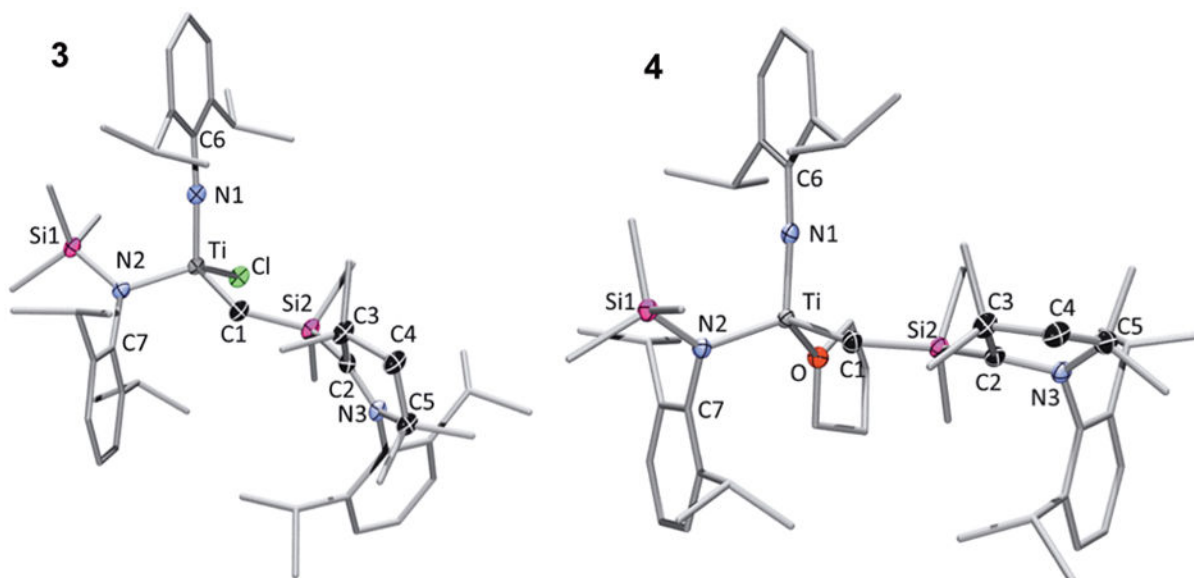
## Acknowledgments

This work was primarily funded by the U.S. Department of Energy, Office of Science, Office of Basic Energy Sciences, Chemical Sciences, Geosciences, and Biosciences Division under Contract No. DE-AC02-05CH11231 (T.D.T.). The EPR investigations were funded by the DOE Office of Science, Chemical Sciences, Geosciences, and Biosciences Division under Contract No. DE-FG02-07ER15903 (K.V.L.). QY is grateful to the Deutsche Forschungsgemeinschaft (DFG) for a postdoctoral fellowship. We acknowledge the National Institutes of Health for funding the UC Berkeley ChexRay X-ray crystallographic facility under Grant No. S10-RR027172 and the Joint Center for Artificial Photosynthesis, a U.S. Department of Energy, Office of Science, Basic Energy Sciences Innovation Hub under Grant No. DE-SC0004993, for EPR facilities. In addition, MSZ was supported by a National Science Foundation Graduate Research Fellowship.

## References

1. Cundari TR. Chem Rev. 2000; 100:807–818. [PubMed: 11749252]
2. a) Schrock RR. J Mol Catal A: Chem. 2004; 213:21–30. b) Bolton PD, Mountford P. Adv Synth Catal. 2005; 347:355–366. c) Hazari N, Mountford P. Acc Chem Res. 2005; 38:839–849. [PubMed: 16285707]
3. a) Williams DN, Mitchell JP, Poole AD, Siemeling U, Clegg W, Hockless DCR, O’Neil PA, Gibson VC. J Chem Soc, Dalton Trans. 1992:739–751. b) Glueck DS, Green JC, Michelman RI, Wright IN. Organometallics. 1992; 11:4221–4225.
4. Schrock RR. Acc Chem Res. 1990; 23:158–165.
5. Roesky HW, Voelker H, Witt M, Noltemeyer M. Angew Chem. 1990; 102:712–713. Angew Chem Int Ed. 1990; 29:669–670.
6. Hill JE, Profflet RD, Fanwick PE, Rothwell IP. Angew Chem. 1990; 102:713–715. Angew Chem Int Ed. 1990; 29:664–665.
7. a) Bytschkov I, Doye S. Eur J Org Chem. 2003:935–946. b) Pohlki F, Doye S. Chem Soc Rev. 2003; 32:104–114. [PubMed: 12683107] c) Odom AL. Dalton Trans. 2005:225–233. [PubMed: 15616708]
8. Adams N, Arts HJ, Bolton PD, Cowell D, Dubberley SR, Friederichs N, Grant CM, Kranenburg M, Sealey AJ, Wang B, Wilson PJ, Cowley AR, Mountford P, Schröder M. Chem Commun. 2004:434–435.
9. a) Cummins CC, Schaller CP, Van Duyne GD, Wolczanski PT, Chan AWE, Hoffmann R. J Am Chem Soc. 1991; 113:2985–2994. b) Bennett JL, Wolczanski PT. J Am Chem Soc. 1997; 119:10696–10719. c) Polse JL, Andersen RA, Bergman RG. J Am Chem Soc. 1998; 120:13405–13414.
10. Hanna TE, Keresztes I, Lobkovsky E, Bernskoetter WH, Chirik PJ. Organometallics. 2004; 23:3448–3458.
11. a) Martin CD, Soleilhavoup M, Bertrand G. Chem Sci. 2013; 4:3020–3030. [PubMed: 23878717] b) Soleilhavoup M, Bertrand G. Acc Chem Res. 2015; 48:256–266. [PubMed: 25515548]
12. a) Kinjo R, Donnadieu B, Celik MA, Frenking G, Bertrand G. Science. 2011; 333:610–613. [PubMed: 21798945] b) Ruiz DA, Ung G, Melaimi M, Bertrand G. Angew Chem. 2013; 125:7739–7742. Angew Chem Int Ed. 2013; 52:7590–7592. c) Bissinger P, Braunschweig H, Damme A, Krummenacher I, Phukan AK, Radacki K, Sugawara S. Angew Chem. 2014; 126:7488–7491. Angew Chem Int Ed. 2014; 53:7360–7363. d) Böhnke J, Braunschweig H, Ewing

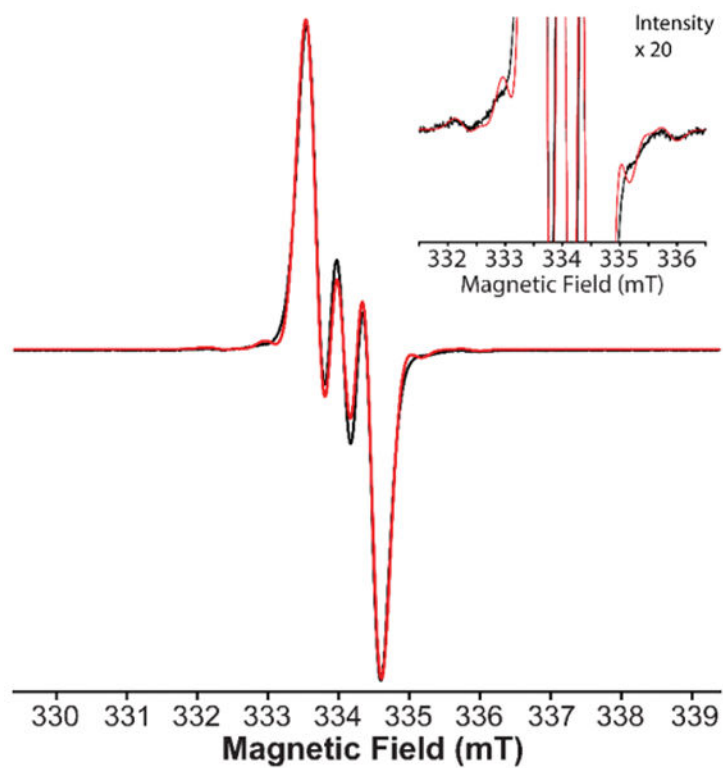
- WC, Hörl C, Kramer T, Krummenacher I, Mies J, Vargas A. *Angew Chem.* 2014; 126:9228–9231. *Angew Chem Int Ed.* 2014; 53:9082–9085.
13. a) Weinberger DS, Melaimi M, Moore CE, Rheingold AL, Frenking G, Jerabek P, Bertrand G. *Angew Chem.* 2013; 125:9134–9137. *Angew Chem Int Ed.* 2013; 52:8964–8967. b) Weinberger DS, Amin NSK, Mondal KC, Melaimi M, Bertrand G, Stückl AC, Roesky HW, Dittrich B, Demeshko S, Schwederski B, Kaim W, Jerabek P, Frenking G. *J Am Chem Soc.* 2014; 136:6235–6238. [PubMed: 24731250] c) Ung G, Rittle J, Soleilhavoup M, Bertrand G, Peters JC. *Angew Chem.* 2014; 126:8567–8571. *Angew Chem Int Ed.* 2014; 53:8427–8431. d) Samuel PP, Mondal KC, Roesky HW, Hermann M, Frenking G, Demeshko S, Meyer F, Stückl AC, Christian JH, Dalal NS, Ungur L, Chibotaru LF, Pröpper K, Meents A, Dittrich B. *Angew Chem.* 2013; 125:12020–12023. *Angew Chem Int Ed.* 2013; 52:11817–11821. e) Singh AP, Samuel PP, Roesky HW, Schwarzer MC, Frenking G, Sidhu NS, Dittrich B. *J Am Chem Soc.* 2013; 135:7324–7329. [PubMed: 23600486]
14. a) Carmalt CJ, Newport AC, Parkin IP, White AJP, Williams DJ. *J Chem Soc, Dalton Trans.* 2002:4055–4059. b) Braunschweig H, Ye Q, Radacki K. *Chem Commun.* 2012; 48:2701–2703. c) Braunschweig H, Dewhurst RD, Radacki K, Wennemann B, Ye Q. *Chem Commun.* 2015; 51:15465–15468.
15. Roy S, Stollberg P, Herbst-Irmer R, Stalke D, Andrada DM, Frenking G, Roesky HW. *J Am Chem Soc.* 2015; 137:150–153. [PubMed: 25539016]
16. a) Lipschutz MI, Tilley TD. *Chem Commun.* 2012; 48:7146–7148. b) Lipschutz MI, Yang X, Chatterjee R, Tilley TD. *J Am Chem Soc.* 2013; 135:15298–15301. [PubMed: 24079707] c) Lin CY, Guo JD, Fettinger JC, Nagase S, Grandjean F, Long GJ, Chilton NF, Power PP. *Inorg Chem.* 2013; 52:13584–13593. [PubMed: 24245921] d) Lin CY, Fettinger JC, Grandjean F, Long GJ, Power PP. *Inorg Chem.* 2014; 53:9400–9406. [PubMed: 25119436] e) Lipschutz MI, Chantarojsiri T, Dong Y, Tilley TD. *J Am Chem Soc.* 2015; 137:6366–6372. [PubMed: 25928273]
17. Jones NA, Liddle ST, Wilson C, Arnold PL. *Organometallics.* 2007; 26:755–757.
18. Jazzar R, Dewhurst RD, Bourg J-B, Donnadiou B, Canac Y, Bertrand G. *Angew Chem.* 2007; 119:2957–2960. *Angew Chem Int Ed.* 2007; 46:2899–2902.
19. Trösch DJM, Collier PE, Bashall A, Gade LH, McPartlin M, Mountford P, Radojevic S. *Organometallics.* 2001; 20:3308–3313.
20. Basuli F, Bailey BC, Huffman JC, Mendiola DJ. *Chem Commun.* 2003:1554–1555.
21. a) Mondal KC, Roesky HW, Schwarzer MC, Frenking G, Niepötter B, Wolf H, Herbst-Irmer R, Stalke D. *Angew Chem.* 2013; 125:3036–3040. *Angew Chem Int Ed.* 2013; 52:2963–2967. b) Xiong Y, Yao S, Inoue S, Epping JD, Driess M. *Angew Chem.* 2013; 125:7287–7291. *Angew Chem Int Ed.* 2013; 52:7147–7150. c) Niepötter B, Herbst-Irmer R, Kratzert D, Samuel PP, Mondal KC, Roesky HW, Jerabek P, Frenking G, Stalke D. *Angew Chem.* 2014; 126:2806–2811. *Angew Chem Int Ed.* 2014; 53:2766–2770.
22. Mondal KC, Roesky HW, Schwarzer MC, Frenking G, Tkach I, Wolf H, Kratzert D, Herbst-Irmer R, Niepötter B, Stalke D. *Angew Chem.* 2013; 125:1845–1850. *Angew Chem Int Ed.* 2013; 52:1801–1805.
23. Mahoney JK, Martin D, Thomas F, Moore CE, Rheingold AL, Bertrand G. *J Am Chem Soc.* 2015; 137:7519–7525. [PubMed: 26011769]
24. Styra S, Melaimi M, Moore CE, Rheingold AL, Augenstein T, Breher F, Bertrand G. *Chem Eur J.* 2015; 21:8441–8446. [PubMed: 25925367]
25. a) Uppal R, Incarvito CD, Lakshmi KV, Valentine AM. *Inorg Chem.* 2006; 45:1795–1804. [PubMed: 16471996] b) Doorslaer SV, Shane JJ, Stoll S, Schweiger A, Kranenburg M, Meier RJ. *J Organomet Chem.* 2001; 634:185–192.



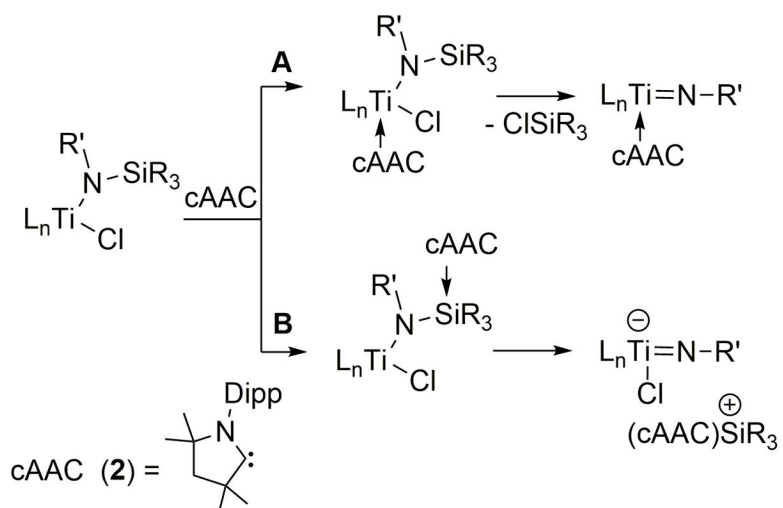
**Figure 1.**

Molecular structure of **3** and **4** in the solid state (ellipsoids set at 50% probability. Hydrogen atoms, solvent molecules and some carbon ellipsoids are omitted for clarity. Selected bond lengths [Å] and angles [°]: For **3**: Ti–N1 1.725(1), Ti–N2 1.967(1), Ti–C1 2.178(2), C1–Si2 1.825(2), Si2–C2 1.984(2), C2–N3 1.295(2), N3–C5 1.550(2), C5–C4 1.523(3), C4–C3 1.543(2), C3–C2 1.525(2), N2–Si1 1.733(1), N1–C6 1.380(2); T1–N1–C6 175.86(12), Ti–C1–Si2 118.65(9), C1–Si2–C2 110.62(7). For **4**: Ti–N1 1.736(2), Ti–N2 1.963(2), Ti–C1 2.150(2), Ti–O 2.062(2), C1–Si2 1.859(3), Si2–C2 1.872(2), C2–N3 1.405(3), N3–C5 1.493(3), C5–C4 1.532(4), C4–C3 1.549(4), C3–C2 1.533(4), N2–Si1 1.737(2), N1–C6 1.387(4); T1–N1–C6 175.43(18), Ti–C1–Si2 121.35(13), C1–Si2–C2 114.83(11).

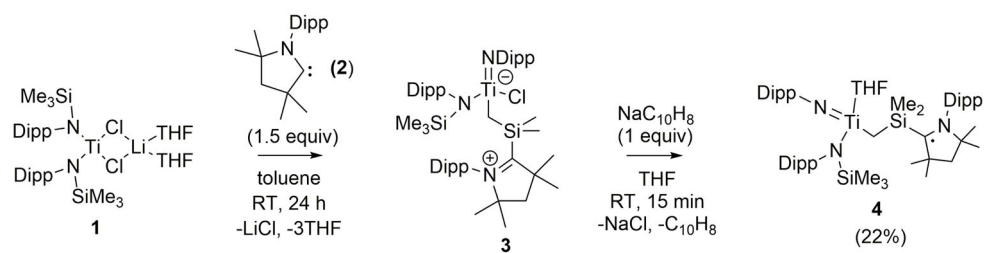




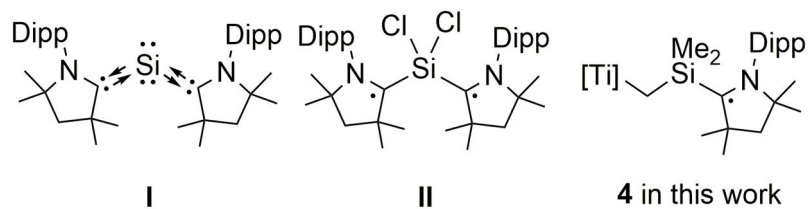
**Figure 2.** Experimental X-band EPR (9.6 GHz) EPR spectrum of **4** (black) in toluene solution at 298 K. In the simulation (red), the  $^{14}\text{N}$ ,  $^{29}\text{Si}$  and  $^{13}\text{C}$  hyperfine interactions are considered.

**Scheme 1.**

Two proposed synthetic routes to titanium imido complexes *via* reactions of titanium silylamido complexes with cAACs.



**Scheme 2.**  
Synthesis of **3** and **4**.

**Scheme 3.**

Structurally characterized, neutral cAAC-stabilized low-valent silicon species with ligand-centered radical or biradical character. **I** represents a significant resonance contributor to the siladiborene structure. Both the singlet and triplet biradical of **II** were isolated as two polymorphs.